

# IntelliTouch Personality Kit & Accessory Installation Manual

IMPORTANT SAFETY INSTRUCTIONS  
READ AND FOLLOW ALL INSTRUCTIONS  
SAVE THESE INSTRUCTIONS



## **⚠ WARNING**

Before installing this product, read and follow all warning notices and instructions which are included. Failure to follow safety warnings and instructions can result in severe injury, death, or property damage. Call (800) 831-7133 for additional free copies of these instructions.

## **Important Notice**



Attention Installer.

This manual contains important information about the installation, operation and safe use of this product. This information should be given to the owner/operator of this equipment.

### **Pentair Pool Products**

1620 Hawkins Ave., Sanford, NC 27330 • (919) 774-4151  
10951 West Los Angeles Ave., Moorpark, CA 93021 • (805) 523-2400



Because **reliability** matters most

## IMPORTANT SAFETY PRECAUTIONS

### **WARNING**

To reduce the risk of injury, do not permit children to use this product unless they are closely supervised at all times.

### **WARNING**

Water temperature in excess of 100 degrees Fahrenheit may be hazardous to your health. Prolonged immersion in hot water may induce hyperthermia. Hyperthermia occurs when the internal temperature of the body reaches a level several degrees above normal body temperature of 98.6° F / 37° C. The symptoms of hyperthermia include drowsiness, lethargy, dizziness, fainting, and an increase in the internal temperature of the body.

The effects of hyperthermia include: 1) unawareness of impending danger; 2) failure to perceive heat; 3) failure to recognize the need to leave the spa; 4) physical inability to exit the spa; 5) fetal damage in pregnant women; 6) unconsciousness resulting in danger of drowning.

### **WARNING**

**The use of alcohol, drugs, or medication can greatly increase the risk of fatal hyperthermia in hot tubs and spas.**

### **WARNING**

Control System is intended to control heaters with built-in high limit circuits **ONLY**. Failure to do so may cause property damage or personal injury.

### **CAUTION**

Except for listed spa-side remote controls, install a minimum of five (5) feet from the inside wall of the pool and spa. Canadian installations require a minimum of three (3) meters from pool water.

### **Important Notice**

This equipment has been tested and found to comply with the limits for a Class B digital device, pursuant to Part 15 of the FCC Rules. These limits are designed to provide reasonable protection against harmful interference in a residential installation. This equipment generates, uses and can radiate radio frequency energy and, if not installed and used in accordance with the instructions, may cause harmful interference to radio communications. However, there is no guarantee that interference will not occur in a particular installation. If this equipment does cause harmful interference to radio or television reception, which can be determined by turning the equipment off and on, the user is encouraged to try to correct the interference by one or more of the following measures:

- Reorient or relocate the receiving antenna.
- Increase the separation between the equipment and receiver.
- Connect the equipment into an outlet on a circuit different from that to which the receiver is connected.
- Consult the dealer or an experienced radio/TV technician for help.

Modifications not expressly approved by the party responsible for FCC compliance could void the user's authority to operate the equipment.

## IMPORTANT SAFETY PRECAUTIONS, (CONT'D.)

1. All work must be performed by a licensed electrician, and must conform to all national, state, and local codes.
2. Install to provide drainage of compartment for electrical components.
3. If this device is used to control underwater lighting fixtures, a ground-fault interrupter (GFCI) must be provided for these fixtures. Conductors on the load side of the ground-fault circuit-interrupter shall *not* occupy conduit, junction boxes or enclosures containing other conductors unless such conductors are also protected by a ground-fault circuit-interrupter. Refer to local codes for details.
4. A terminal bar stamped  $\oplus$  is located inside the supply terminal box. To reduce the risk of electric shock, this terminal must be connected to the grounding means provided in the electric supply service panel with a continuous copper wire equivalent in size to the circuit conductors supplying this equipment (no smaller than 12 AWG or 3.3mm). The bonding lug(s) provided on this unit are intended to connect a minimum of one No. 8 AWG for US installation and two No. 6 AWG for Canadian installations solid copper conductor between this unit and any metal equipment, metal enclosures or electrical equipment, metal water pipe, or conduit within 5 feet (1.5m) of the unit.
5. The electrical supply for this product must include a suitably rated switch or circuit breaker to open all ungrounded supply conductors to comply with Section 422-20 of the National Electrical Code, ANSI/NFPA 70.1987. The disconnecting means must be readily accessible to the tub occupant but installed at least 10 ft. (3.05 m) from the inside wall of the pool.
6. Minimum supply conductor and circuit ampacity 125 Amps.

RECOMMENDED HYDRAULIC SCHEMATIC

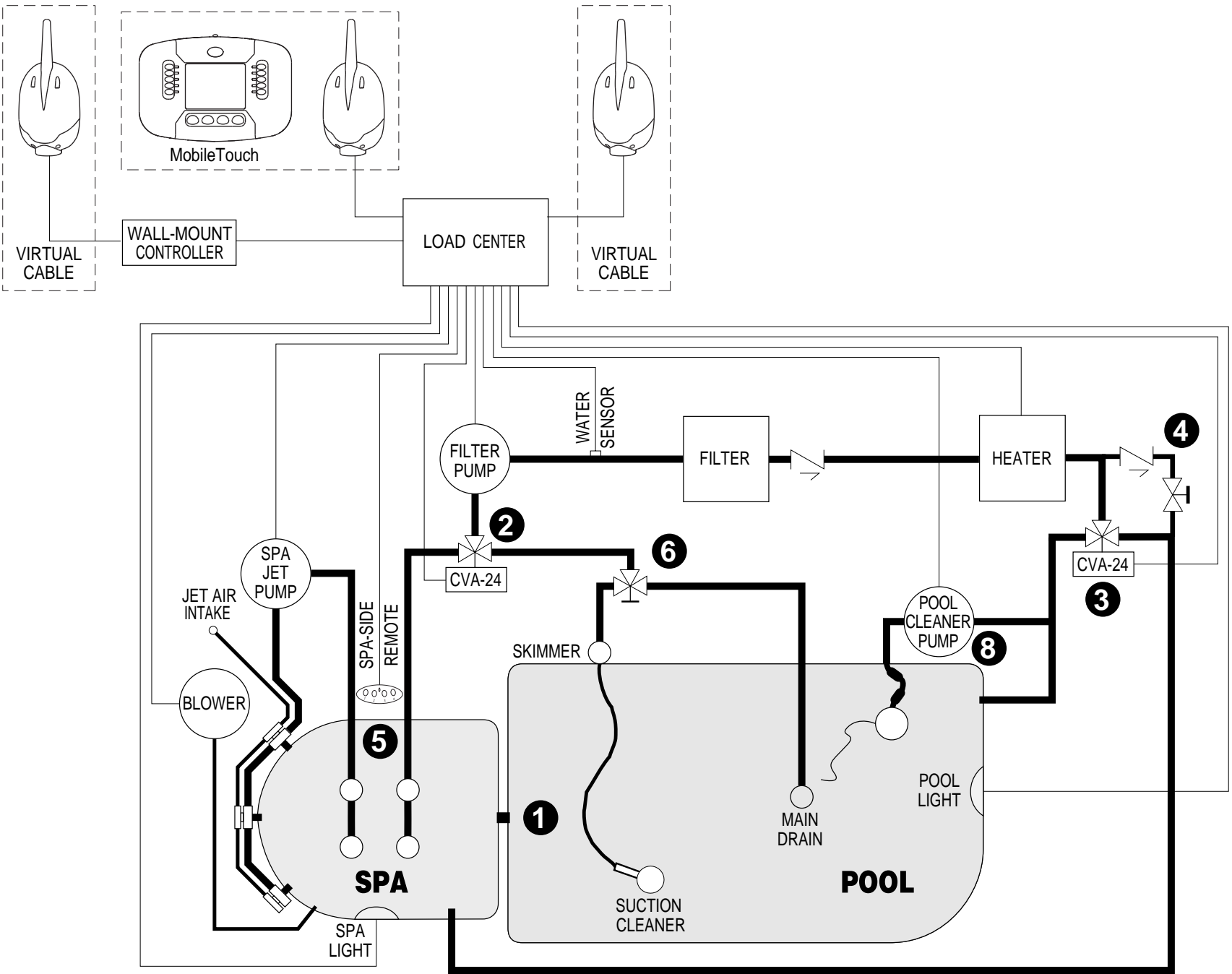

Figure 1.

## PLUMBING REQUIREMENTS

Plumb system in accordance with ‘**RECOMMENDED HYDRAULIC SCHEMATIC**’ on page 3, local codes and the following guidelines.

Bring all lines back to the equipment pad.

1. **Spa should be at or above the level of the pool.**

If spa is attached to pool, provide a dam between the two bodies of water to allow spa overflow into pool. If spa is not attached to pool, an overflow, sufficient in size to carry full pump-flow, must be installed at water level in the spa.

2. Plumb a three-port **Intake Valve** on the suction-side of the filter pump, so that center port of valve is connected to the pump inlet.

Connect spa suction to one side of Intake Valve, and pool suction to the other side.

3. Plumb a three-port **Return Valve** on the return-side of the heater, so that return water will enter valve through the center port.

Connect spa return to one side of Return Valve, and pool return to the other side.

4. A ½ in. spa make-up line (incorporating a ½ in. manual gate or ball valve and, for elevated spas, a ½ in. check valve) may be provided to bypass the pool return line. This will enable some of the chemically-balanced water from the pool to cycle through the spa. The manual valve will allow the amount of bypass to be adjusted.

5. If the spa is to be constructed in concrete, special provision should be made at this time for the installation of the **Spa-side Remote Control**.

Select a convenient location in the deck or above water level in the spa wall (where the Spa-side Remote will not be submerged by the spa water), and install a 6 in. to 12 in. length of 1 in. PVC pipe to provide a receptacle for the Spa-side Remote. The pipe should be level and protrude beyond the finished surface of the spa. It will be cut back at a later date. Reduce pipe size down to ½ in. or ¾ in. conduit, and run to proposed Load Center location at equipment pad. Use sweep elbows for turns.

**The Spa-side Remote will not be installed until spa construction is complete.**

6. For systems which incorporate a skimmer, it is possible to balance the amount of suction between the skimmer and main drain for maintenance purposes.

This is easily accomplished by installing a manual three-port mixing valve at the suction line.

Plumb one port to the skimmer and the other to the main drain.

7. If a “non-booster pump” pressure-side pool cleaner is being used, plumb a manual three-port valve between the filter pump and filter, with the third port plumbed to the pool cleaner line, and install a motorized two-port **Pool Cleaner Valve** at this line. The motorized valve will automatically open whenever the Control System activates the pool cleaner.

8. If a booster pump pool cleaner is being used, plumb the booster pump so that its suction-side is connected to the pool return, after the heater and as close to the ground as practical.

# HIGH VOLTAGE CONNECTIONS

## **⚠ WARNING**

It is required that the main power into the home be switched off at the main circuit breaker box whenever the high voltage cover panel is removed. This is also required to access the low voltage raceway.

### LOAD CENTER

Near the pool equipment pad is mounted the Load Center Foundation. When the Personality Kit control panel is added the Load Center is completed. The Load Center receives control inputs and distributes high voltage power. The major features of the Load Center are shown in Figure 3. Not shown is the high voltage cover panel.

See WARNING above.

### INSTALL AUXILIARY POWER RELAYS

Install additional relays as needed. Depending on the Personality Kit there may be as many as five additional relays included. Feed low voltage relay wires through holes in voltage barrier. Wires will plug into circuit board upon installation of control panel.

### INSTALL SPECIAL-PURPOSE RELAYS

#### Two Speed Pump Relay

Obtain Pentair Pool Products P/N 520198.

Three positions are available below the Power Relays to install the Two Speed Pump Relay. Connect load lines between the relay dedicated for the pump as shown in Figure 2. Feed low voltage relay wires through holes in voltage barrier.

### EXPANSION UNITS

**(Only available with i7+3 and i9+3 Personality Kits)**

Up to three expansion units may be added to the systems above. First, Load Center Foundations must be installed. Follow all other instructions for installation of Personality Kits.

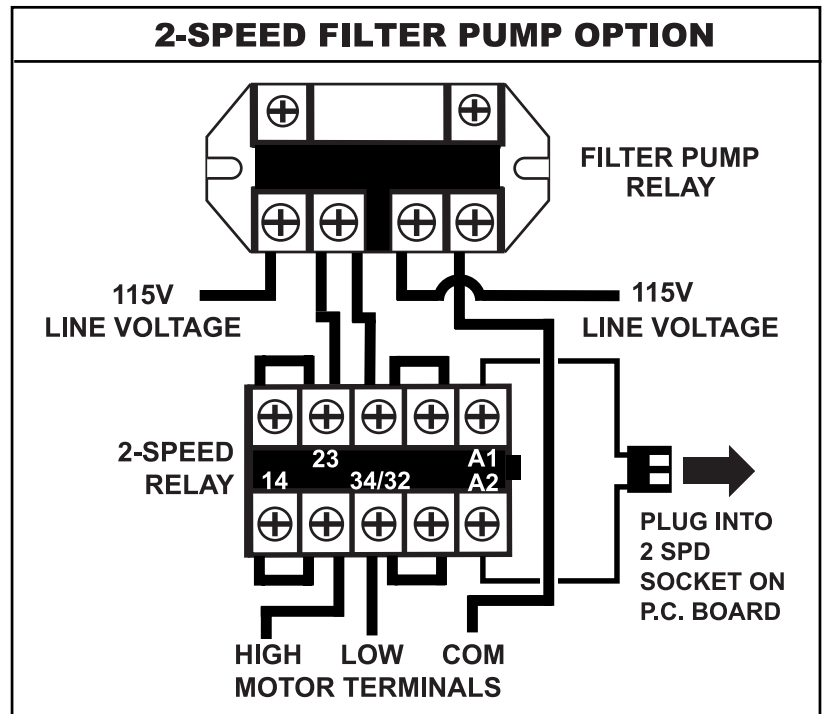

Figure 2.

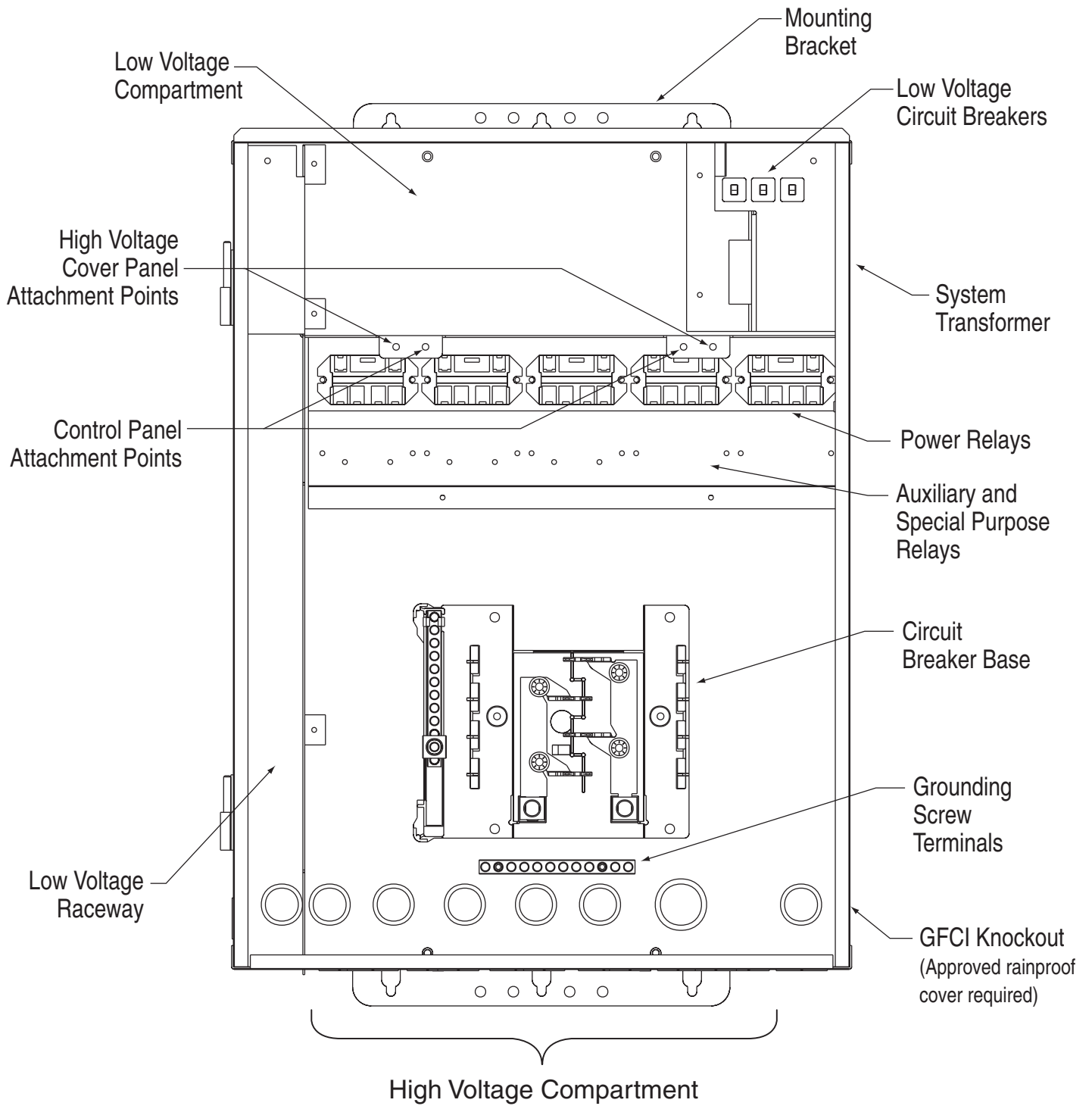

Figure 3.

# PERSONALITY KIT AND EQUIPMENT PAD CONNECTIONS

## INSTALL CONTROL PANEL

At the Load Center, remove the high voltage cover panel. Remove the outdoor control panel from separate packaging and secure to top portion of Load Center with two screws at bottom edge of control panel next to high voltage cover panel screw holes. The control panel has clearance holes to accommodate high voltage cover panel retaining screws. The control panel will now hinge out and down to facilitate low voltage connections. The control panel may be held closed using the two screws in the upper corners. See Figure 4 to reference all further low voltage connections.

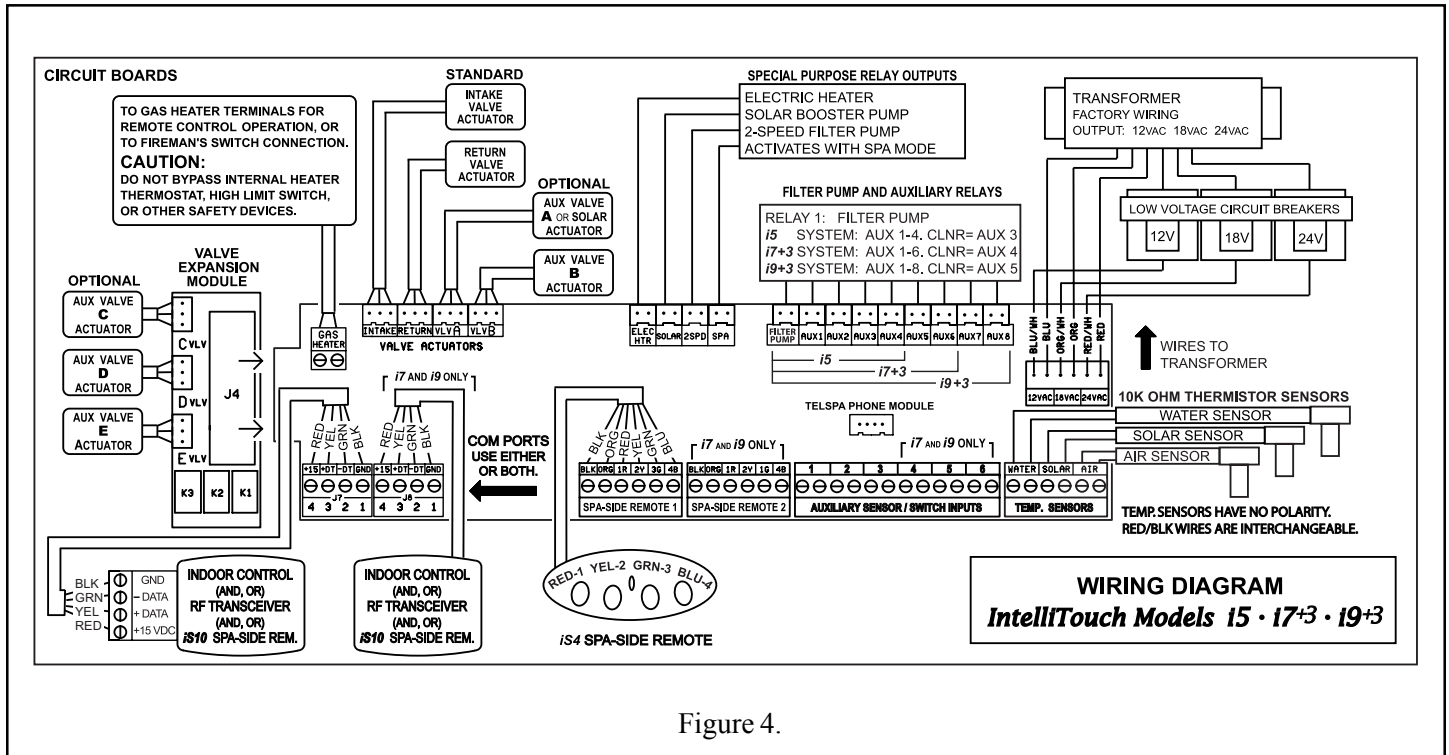

Figure 4.

## CONNECT TRANSFORMER

Plug transformer wire harness into right side of control board. Note keyed plug fits onto pins so that the six wires point towards back or top of Load Center. From left to right the wire colors should be blue, orange, red.

## CONNECT RELAYS

Plug power relay coil wires from high voltage compartment into 2-pin sockets beginning from left with Filter, then Aux1 – Aux4. If additional relays have been added, plug these into Aux5 – Aux8. If a 2-speed relay has been installed plug into 2SPD socket of Personality PCB.

## INSTALL VALVE ACTUATORS

Mount valve actuators to valves by removing 4 screws indicated with arrows on valve cover and mounting valve actuator with provided screws. See instructions included with actuators. Run cables to low voltage raceway on bottom left side of Load Center, and pull through low voltage raceway to the low voltage compartment of Load Center. Plug valve actuators into Intake (suction) and Return 3-pin sockets on left side of control board. If applicable, mount auxiliary and/or solar valve actuators and plug into 3-pin sockets, Valve A and B. Excess cable may be coiled in raceway, but must not be coiled in low voltage compartment.

If additional valve actuators are required, a valve module expansion board (P/N 520192) may be acquired and attached to left end of the personality PCB to add up to three valve actuators. Attachment of valve actuators may be performed in an identical manner as mentioned above.



## **INSTALL AND CONNECT TEMPERATURE SENSORS (2 INCLUDED)**

### **Water Temperature Sensor**

Drill 5/16 in. hole in plumbing between filter pump and filter. Insert tip of sensor into hole. Use band clamp to secure sensor to pipe. Tighten clamp just enough so o-ring begins to flatten. Do not over-tighten. Run wire through low voltage raceway to control panel, fastening to plumbing with cable ties. Cut off excess wire and strip conductors ¼ in. Connect wires to WATER screw terminals on right edge of board.

### **Ambient Air Temperature (Freeze Protection) Sensor**

Mount sensor in open air, in shaded area, away from air conditioners. Run wire through low voltage raceway to control panel, fastening to plumbing with cable ties. Cut off excess wire and strip conductors ¼ in. Connect wires to AIR screw terminals on right edge of board.

### **Solar Temperature Sensor (Optional)**

Mount sensor on flat surface, with same exposure to sun as solar collectors (adjacent suggested). Do not let sensor touch panels. Splice 2-conductor extension wire to sensor if necessary and run wire to control panel. Strip conductors ¼ in. and connect to SOLAR screw terminals on right edge of board.

## **CONNECT HEATER TO CONTROL SYSTEM**

The following instructions are for gas heaters and heat pumps with low voltage thermostats:

1. Run a 2-conductor cable from the heater thermostat area to low voltage section of Load Center. Strip conductors ¼ in. and connect wires to GAS HEATER screw terminals on left side of board.
2. At heater, connect wires in accordance with heater manufacturer's instructions. For older heaters without instructions for remote operation, connect wires to Fireman's switch connections, in series with thermostat, pressure switch and other safety switches.
3. Do **NOT** disconnect or wire around thermostat, pressure switch, high limit switch, or other safety devices.
4. Choose Pool or Spa thermostat and toggle heater to that setting.
5. Turn thermostat for chosen setting to maximum.

## **CONNECT EXPANSION UNITS**

Attach Personality Kit control panel as described above. Run UL approved four 22AWG conductor cable from any COM PORT of the control panel PCB of the base system to any COM PORT of the expansion system. Strip conductors ¼ in. and attach to screw terminals. Additional expansion units may be connected by doubling-up wires in the screw terminals.

# CONTROLLER INSTALLATION

## INDOOR CONTROL PANEL

The Indoor Control Panel provides hardwired control of the IntelliTouch system from inside the home. Select a convenient location inside the house or other weather-protected area for the wall mounted controller. The width of the control panel is 5- $\frac{3}{4}$  in.

1. Four holes are required to mount the unit: three for mounting screws, and one for the communication cable. Using the template below (Figure 5), mark the wall where the mounting holes will be made. If screws will not be screwed into studs drill  $\frac{3}{16}$  in. holes and insert wall anchors (included) as required. Drill fourth hole large enough for cable to feed through (approx.  $\frac{1}{4}$  in.) within the bounds of the template but outside the areas indicated.

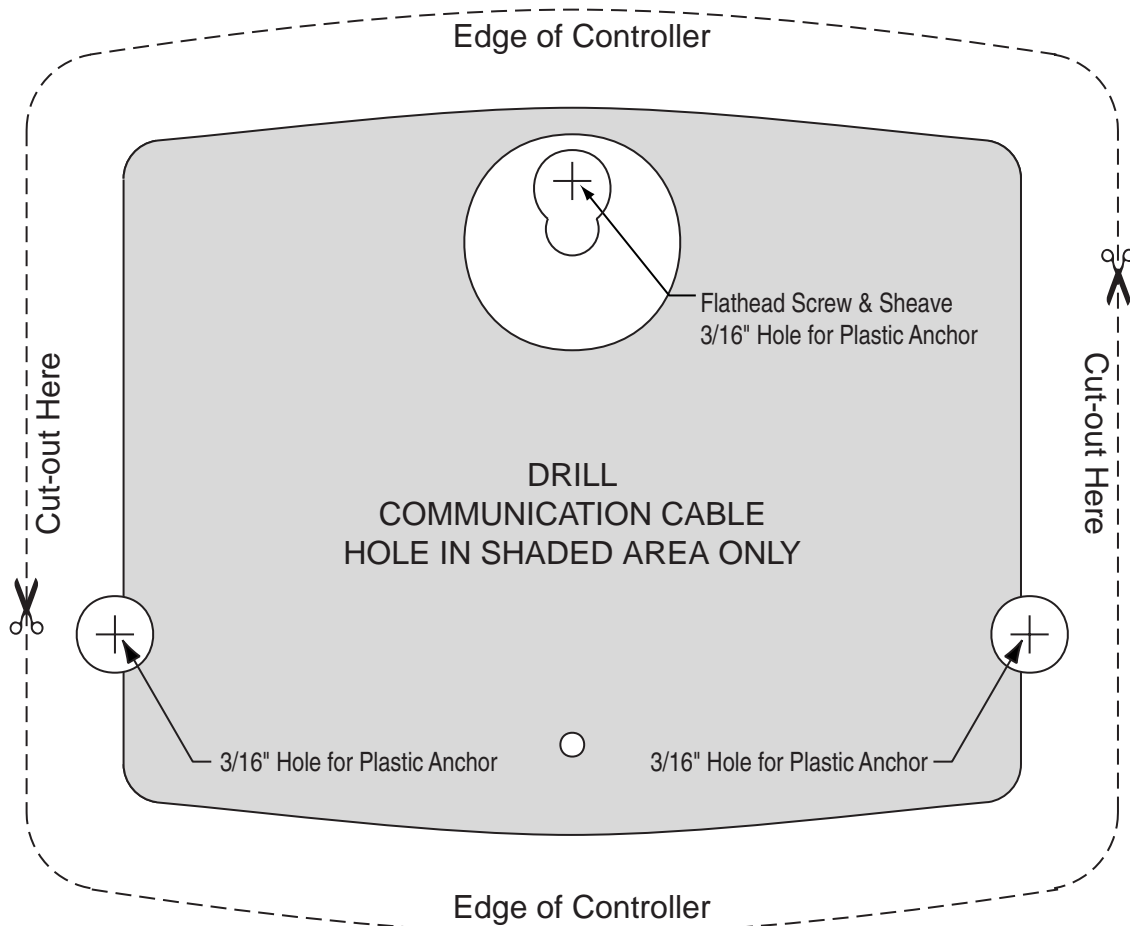

Figure 5.

2. Turn off the system power before making any connections. Run a UL approved four 22 AWG conductor cable from the Load Center control panel. The preferred wire color scheme is: red, yellow, green, and black.

### **CAUTION**

Do NOT short GND or +15V connections (Red or Black) to data lines (Green or Yellow). PCB's may be permanently damaged. Do NOT reverse GND or +15V or system will not operate.

3. The cable must be fed through the low voltage raceway of the Load Center. Strip the communication cable conductors at the Load Center ¼ in. Open the control panel and fold down to make connections. To the left of the board are the COM PORT terminal connector(s). Attach to any COM PORT terminal connector.

4. Run the cable through the house wall to the location of the Indoor Control Panel and bring a working length of the communication cable out of the wall.

5. Drill the flathead screw provided through the mounting sheave and into the wall as shown in Figure 6.

6. Remove the cover plate from the controller. Do this by pulling on the top or bottom edge of the cover plate with the fingers and pressing gently on the screen with the thumb.

7. Strip the leads of the communication cable conductors ¼ in. and attach to controller plug screw terminals as shown in Figure 7. Be sure to match color-coding of the wires to the controller PCB marking on the back. An optional cable clip feature has been built into the back plate to help guide the communication cable. Feed the cable back into the wall so that the remainder left outside the wall will fit behind the back plate.

8. Slide the back plate with electronics over the mounting sheave and slide down. Rotate back plate as necessary to make level. The bottom mounting holes should be visible through cutouts in the PCB.

9. Carefully screw pan head screws into wall to hold plate. The back plate should rest firmly against the wall.

10. **NOTE:** Remove the clear protective plastic sheet from LCD screen. Snap cover over back plate.

11. Turn system power on.

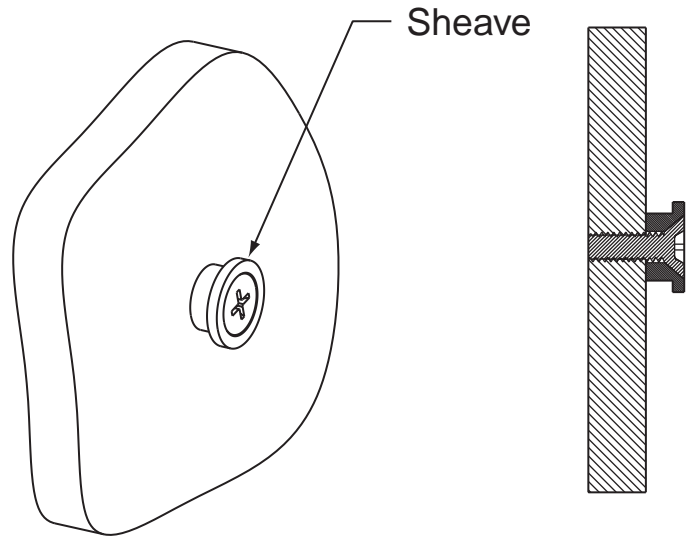

Figure 6.

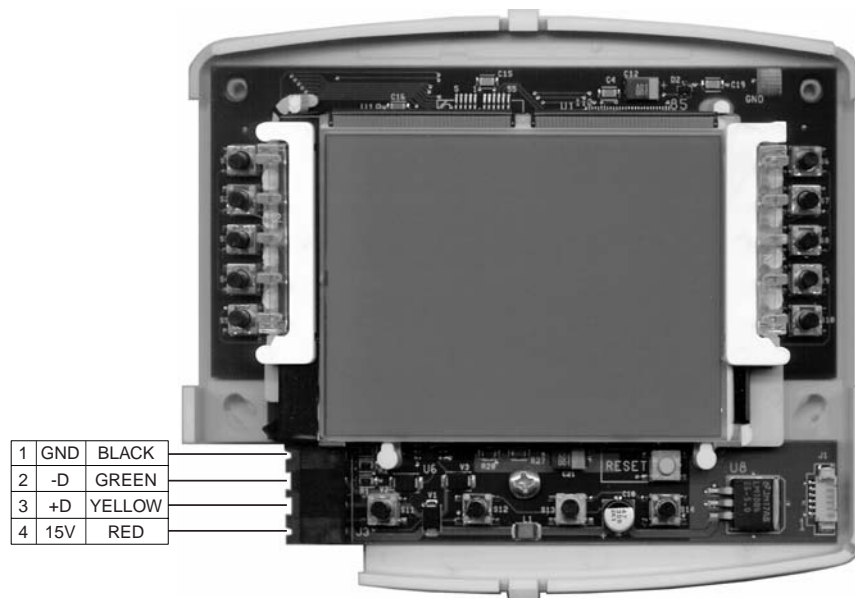

Figure 7.

## MOBILETOUCH CONTROLLER

The MobileTouch Controller provides wireless control of the IntelliTouch system. The controller consists of a hand-held unit, recharging transformer, and transceiver antenna assembly.

### **⚠ WARNING**

Do not plug in recharging transformer within five (5) feet of the pool and spa. Canadian installations require a minimum of (3) meters from pool water. Do not recharge outdoors.

### **⚠ CAUTION**

The hand-held unit is NOT intended to be submersible. Remove unit immediately if dropped in water.

### **⚠ CAUTION**

Do not leave in direct sunlight for extended periods of time. If screen darkens, place in shade for five minutes or until screen returns to normal before using. Do not adjust contrast. Screen will become too light to see when screen cools.

The range of the unit may be up to 300 feet. The unit may be used all day at full power with a complete battery charge (4-5 hours). With a charge time of 10-15 minutes on a dead battery, usage may be up to an hour. Charge the hand-held unit by plugging into wall using the recharging transformer (included).

When unplugged, turn unit on by depressing button at middle-top of unit (next to antenna). It is best to set the unit to turn off in 5 minutes.

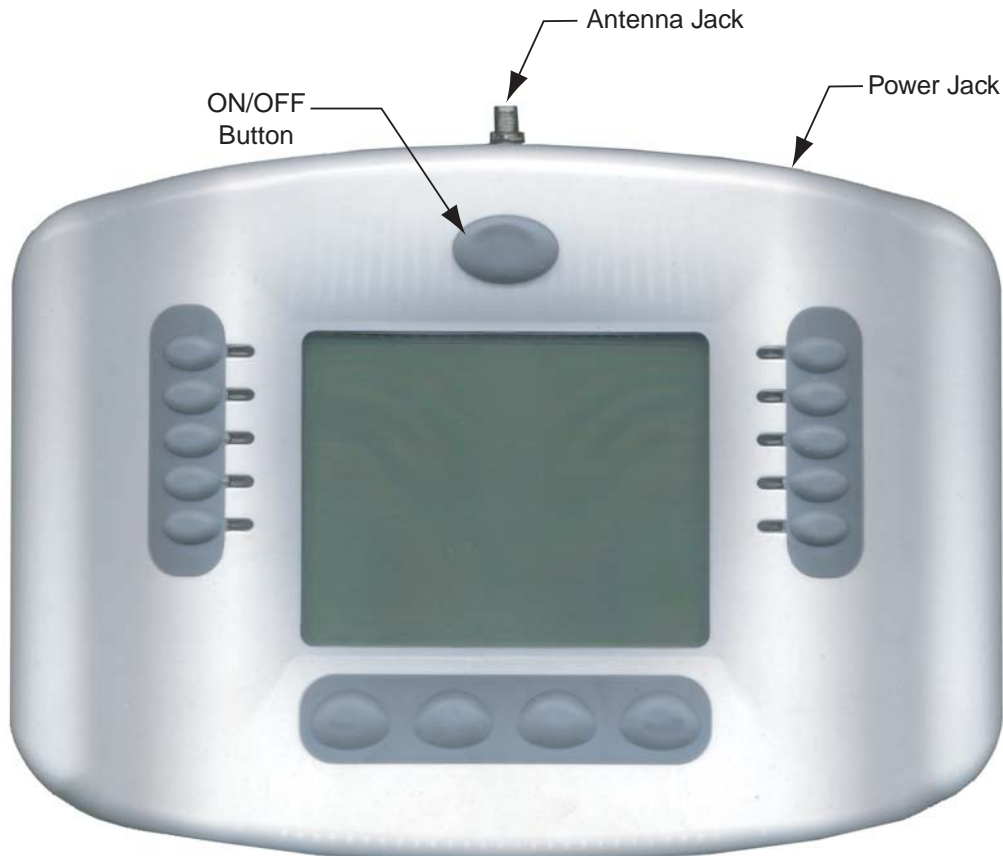

Figure 8.

## Transceiver

The transceiver should be mounted at a convenient location (on a flat vertical surface) a minimum of 5 ft. above ground level to optimize the functional range of the hand-held unit. See Figure 9 for major features.

### CAUTION

The transceiver should be mounted a minimum of 8 to 10 feet away from any air blower, which may be part of the equipment set. The transceiver will not operate properly if it is close to a blower that is operating.

1. In order to mount the transceiver, it will be necessary to remove the two retaining screws located on the underside of the transceiver, and carefully slide the transceiver case up and off of its back plate.
2. Temporarily position the back plate against its mounting surface so that the transceiver is oriented in an upright position (with antenna pointing upwards).
3. The circuit board will need to be temporarily removed. Slide the board up and out of the back plate. Use a pencil to mark the four mounting points, and drill 3/16 in. dia. holes. Insert the four plastic anchors (provided).
4. Feed a UL approved four 22AWG conductor cable through one of the drain holes at the bottom of the receiver enclosure. The preferred wire color scheme is: red, yellow, green, and black. If the drain holes are not used, drill a hole through the bottom of the back plate and seal using a fitting with a few feet of conduit or some other sealant between the case and the cable.
5. Reposition the back plate over the mounting points and secure with the four mounting screws (provided).
6. Strip the leads of the wires about 1/4 in. and attach to controller screw terminals of terminal plug as shown in Figure 10. Carefully slide the circuit board back into the back plate and connect the terminal plug.
7. Then slide the Receiver case back onto the back plate, and secure using the two retaining screws.

### CAUTION

Water damage may occur if the enclosure retaining screws are not secured or a new hole is drilled for the cable and not sealed. Do not seal drain holes.

## Load Center

Feed the four conductor cable from the transceiver up the low voltage raceway. Open the control panel and fold down to make connections. To the left of the board are the COM PORT connector(s). Strip the leads of the wires about 1/4 in. and attach to controller screw terminals of any COM PORT terminal plug following the wiring diagram.

Close control panel, high voltage cover panel, and Load Center door. Turn power to system back on.

## Hand-Held Unit

Charge the hand-held unit by plugging into wall using the recharging transformer (included). A full day's usage requires a complete battery charge (4-5 hours). With a charge time of 10-15 minutes on a dead battery, usage may be up to an hour. When unplugged, turn unit on by depressing button at middle-top of unit (next to antenna).

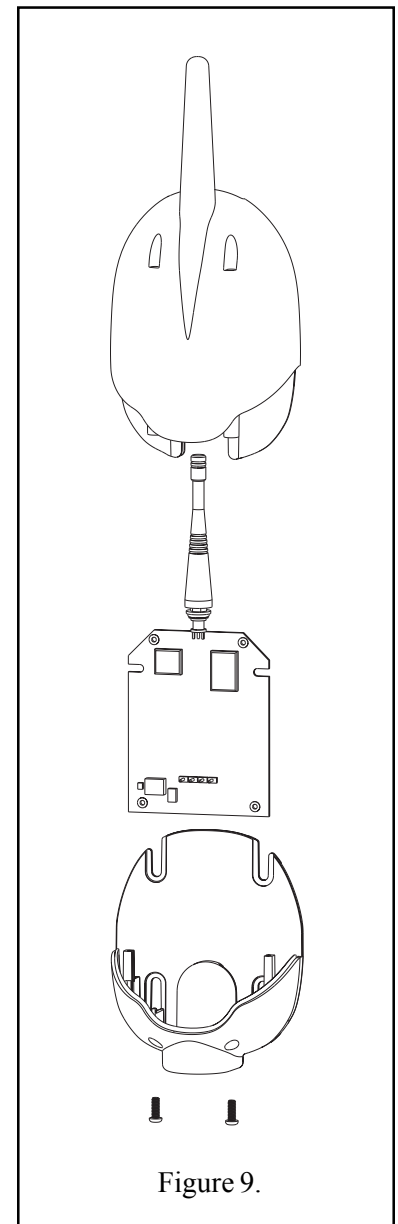

Figure 9.

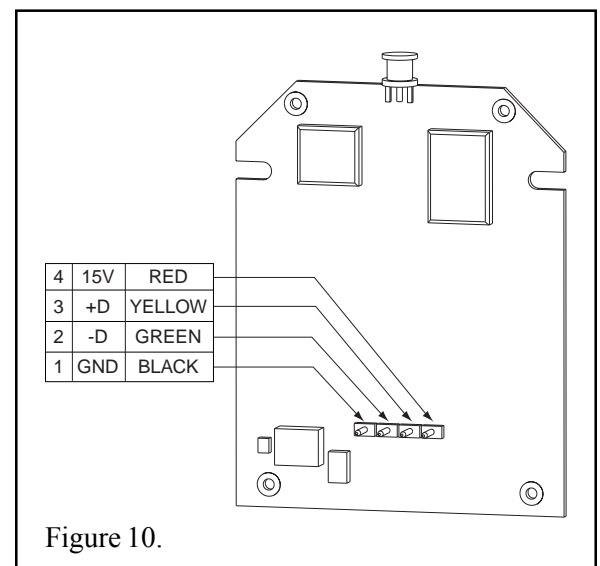

Figure 10.

## ACCESSORY INSTALLATION

### VIRTUAL CABLE

The Virtual Cable accessory kit gives wireless communication capability to an Indoor Control Panel for installations where hardwired control is not feasible. This unit may be operated with any other IntelliTouch controller accessory. Before installation, the Load Center, Personality Kit and Indoor Control Panel must be obtained separately.

#### ***Kit includes:***

- 1 Transformer
- 2 Transceiver assemblies with enclosure

#### **Transformer**

Select a convenient indoor location where the transformer may be plugged into an outlet. A UL approved two 22AWG conductor cable will need to be run from the transformer to the Indoor Control Panel location. The cable may be run inside the wall and emerge behind the control panel. If necessary, have a qualified electrician install such an outlet and run the cable. Note the polarity of wires (1 BLACK, 4 RED).

#### **Transceivers**

Two transceivers are provided for the Virtual Cable: one to be connected to the Indoor Control Panel, another to be connected to the Load Center. Select an outside location where the Indoor Control Panel transceiver may be conveniently wired to the Indoor Control Panel. Select another outside location near the Load Center to conveniently wire the Load Center transceiver. The transceivers should be mounted a minimum of 5 ft. above ground level to optimize the range of the transceivers.

### **⚠ CAUTION**

The transceiver should be mounted a minimum of 8 to 10 feet away from any air blower, which may be part of the equipment set. The transceiver will not operate properly if it is close to a blower that is operating.

1. Follow steps 1 through 7 of the MobileTouch transceiver for mounting the Virtual Cable transceivers. The parts are identical.
2. Feed the Indoor Control Panel transceiver cable through the wall to emerge behind the Indoor Control Panel.
3. Feed the Load Center transceiver cable to the Load Center following the instructions of the MobileTouch Load Center.

### **⚠ CAUTION**

Water damage may occur if the enclosure retaining screws are not secured or a new hole is drilled for the cable and not sealed. Do not seal drain holes.

#### **Indoor Control Panel**

See the installation instructions of the Indoor Control Panel with the exception of the cable connections. Run the four conductor cable from the transceiver and the two conductor cable from the transformer to the Indoor Control Panel location. Strip the leads of the wires about ¼ in. and attach to controller plug screw terminals, see Figure 7. Be sure to match color-coding of the wires to the controller PCB marking on the back. The preferred wire color scheme is: red, yellow, green, and black. Connect the positive line of the transformer to red and the ground to black. Multiple wires may be inserted into a single screw terminal.

## INSTALL 4-FUNCTION SPA-SIDE REMOTE CONTROL

The iS4 may be used in conjunction with IntelliTouch Control Systems to provide remote switching of four control circuits from the spa location. It is typically used for activating spa circulation and three auxiliary pieces of equipment (such as lights, jet pump, air blower, etc.). The red LED status light comes on steady in Spa mode and flashes while heating.

### Location

The iS4 spa-side remote is a double-insulated, waterproof device that is UL-listed (to UL 1563). Recommended installation is four inches above the water's edge for convenient longer life. The remote control may be mounted in the tile line or in the deck within arm's reach of a spa occupant. It can be used with a gunite spa, acrylic spa, or hot-tub. However, in order to install the spa-side remote into the wall of a gunite spa, provision must be made while the spa is being plumbed.

NOTE: If the Load Center to which the spa-side remote is connected is not located above the spa water level, a junction box should be provided (above water level).

### Gunite Spa Application

When plumbing the spa, install a 3 in. to 6 in. length of 1 in. Sch. 40 PVC pipe (perpendicular to the spa wall) to provide a receptacle for the spa-side remote. It is advisable that this pipe be plumbed as level as possible. However, the unique "eyeball" design built into the remote will compensate for a discrepancy of up to 15°. See Figure 11.

The pipe should protrude beyond the finished surface of the spa, as it will be cut back after surface-finishing is completed. Outside the spa, the conduit size may be reduced down to ½ in. or ¾ in., and run to the Load Center. Use sweep elbows for turns.

NOTE: For new gunite spa installations, the iS4 Mounting Adapter has no purpose and can be discarded.

When the spa construction is completed, cut back the 1 in. dia. PVC conduit receptacle flush with the spa wall finish or surface of deck. Run spa-side remote cable through conduit and into Load Center low voltage raceway. Strip the conductors at the Load Center by ¼ in. Use Figure 12 and the color call-out description on back of remote to wire unit to six position terminal connector on back of Load Center control panel labeled SPA-SIDE REMOTE 1 or 2.

Affix remote to 1 in. dia. PVC conduit using a small amount of caulking or RTV. Orient unit per Figure 13 for optimum usage by spa occupant. Attach appropriate labels to remote.

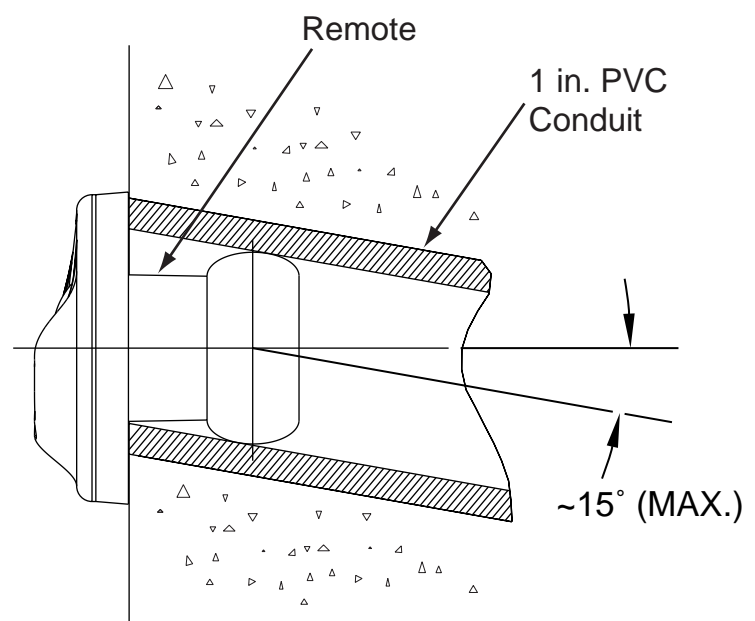

Figure 11.

**NOTE: Do NOT affix unit with epoxy to enable future upgrades.**

## Acrylic Spa Or Hot-Tub Application

Obtain optional Spa Wall Mounting Adapter and lock-nut (P/N SSADP). Drill 1-5/8 in. dia. hole in wall of spa or hot-tub. Insert Spa Wall Mounting Adapter, and use lock-nut on external surface of wall to secure Spa Wall Mounting Adapter into place. See Figure 14. Glue 1/2 in. PVC conduit directly into back of the Spa Wall Mounting Adapter and run conduit to the Load Center. Use sweep elbows for turns. Bond iS4 Mounting Adapter provided over Spa Wall Mounting Adapter using caulking or RTV. Run spa-side remote cable through conduit to power center. Affix remote to iS4 Mounting Adapter using small amount of caulking or RTV. Attach appropriate labels to remote.

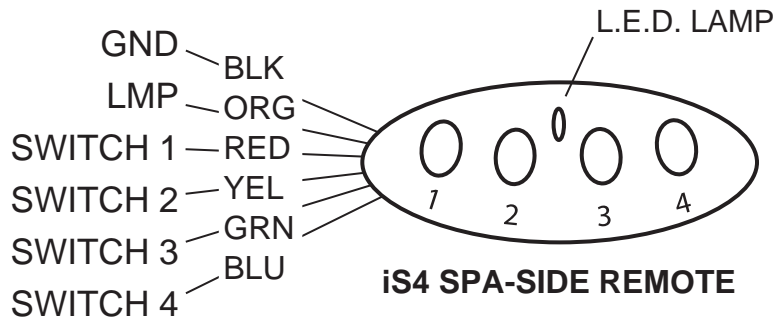

Figure 12.

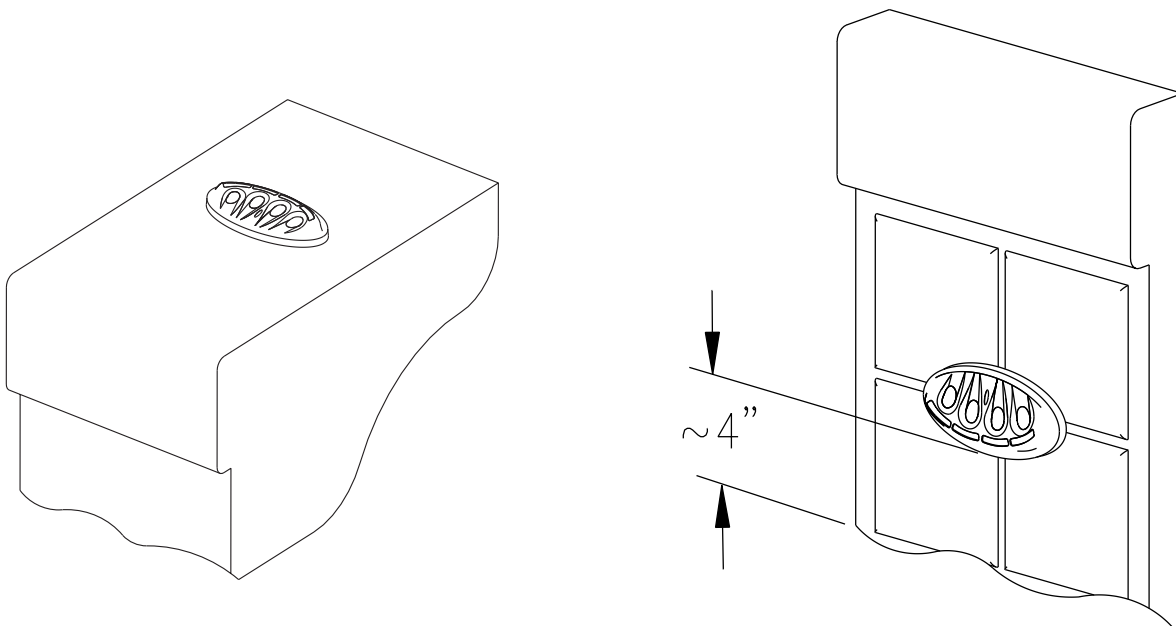

Figure 13.

**NOT TO SCALE**



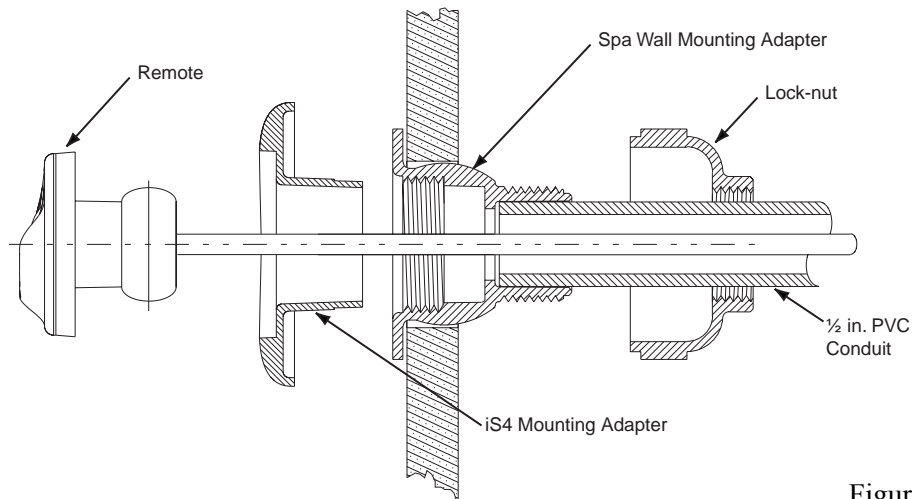

Figure 14.

### Upgrade For SS4 Application

Remove existing SS4 making note of function and button color. Orient iS4 Mounting Adapter to optimize usage by spa occupant per Figure 13. Bond iS4 Mounting Adapter provided over existing Mounting Adapter using caulking or RTV. Run spa-side remote cable through conduit to Load Center. See Figure 15. Use the color call-out description on back of remote to wire unit. Affix remote to iS4 Mounting Adapter using small amount of caulking or RTV. Attach appropriate labels to remote.

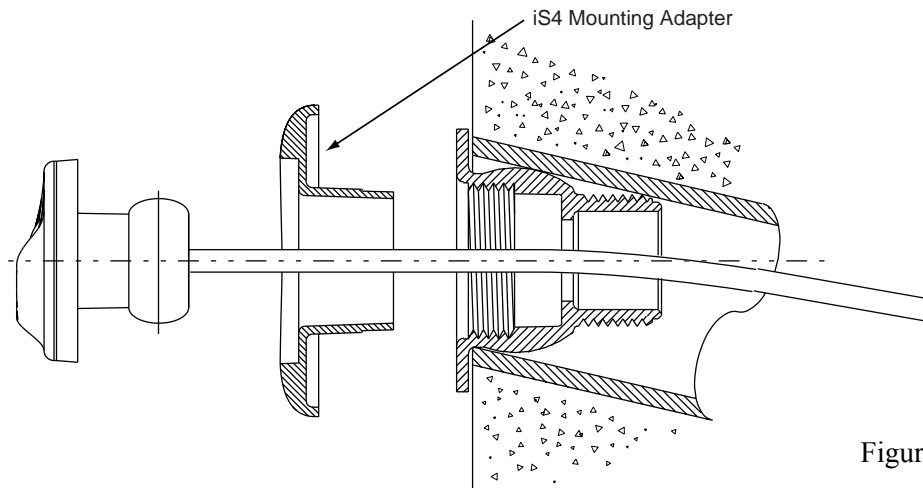

Figure 15.

### INSTALLING A SECOND 4-FUNCTION SPA-SIDE REMOTE CONTROL

A second spa remote may be installed to operate the same four functions or operate an additional four functions.

#### To Operate Same 4 Functions

Connect wires from second remote to same terminals as first remote.

#### To Operate An Additional 4 Functions

##### (Only available with i7+3 and i9+3 Personality Kits)

Connect wires from second remote to SPA-SIDE REMOTE 2 terminals. Upon start-up, the spa-side remote will control the Aux 4 through Aux 7. If control of other circuits is desired, the system may be reconfigured in the Set-Up procedure with the user panel.

## GLOSSARY OF TERMS

**Expansion Kit:** Personality Kit that is dedicated to add additional auxiliaries to an existing Personality Kit; requires a Load Center Foundation for each Expansion Kit.

**Feature Circuits:** programmable circuits that may control relays and/or valve actuators.

**High Voltage Compartment:** large lower right compartment of Load Center for all high voltage wiring including circuit breakers, relays, and GFCI.

**Indoor Control Panel:** fourteen button controller with LCD (liquid crystal display) mounted indoors on the wall to control IntelliTouch Systems.

**iS4:** four function spa-side remote; may be spa wall or deck mounted.

**iS10:** up to ten function spa-side remote with temperature changing capability; may be spa wall or deck mounted.

**Load Center:** unit for distributing power for controlling IntelliTouch systems that includes Load Center Foundation, Personality Kit, and circuit breakers.

**Load Center Foundation:** metal case with relays, transformer, and breakers to be installed prior to Personality Kit installation; common to all Personality Kits.

**Low Voltage Compartment:** top most compartment of Load Center for all low voltage wiring.

**Low Voltage Raceway:** vertical space in left side of Load Center for low voltage cabling.

**MobileTouch Controller:** wireless controller for the IntelliTouch systems with all the functionality of the Indoor Control Panel.

**Mud Box:** enclosure to provide mounting features for iS10 spa-side remote that is cast into gunite, concrete, or other spa wall/deck construction.

**Outdoor Control Panel:** control panel with flexible hinge installed in upper portion of Load Center to control IntelliTouch systems.

**Personality Board/PCB:** circuit board on Outdoor Control Panel that defines system capabilities; outermost circuit board on Outdoor Control Panel.

**Personality Kit:** set of parts to define the capability of a system; may include: Outdoor Control Panel, temperature sensors, actuators, control panel (Indoor or MobileTouch), additional relays, actuators.

**Power Center:** same as Load Center except without the circuit breakers.

**Relay Circuits:** circuits to control relays on Personality Board along top edge from the middle to the right of the PCB.

**PCB:** printed circuit board.

**Terminal Connector:** removable connector that may attach to PCB with multiple sockets (anywhere from 2 to 12) to receive wires from controllers and sensors; wires held by screw terminals; multiple wires of a small enough gage (usually 22 AWG) may be coupled to a single socket of a terminal connector.

**Transceiver:** special printed circuit board that can send and receive radio frequency (wireless) transmissions.

**Virtual Cable Accessory Kit:** set of parts to give wireless capability to an Indoor Control Panel; replaces the need to run cable from equipment pad to the home.

## SAVE THESE INSTRUCTIONS.



***Pentair Pool Products***

1620 Hawkins Ave., Sanford, NC 27330 • (919) 774-4151

10951 West Los Angeles Ave., Moorpark, CA 93021 • (805) 523-2400

