

QuickTouch (QT4) Owner's Manual

4-Function Hand-Held Wireless Remote Control

IMPORTANT SAFETY INSTRUCTIONS
READ AND FOLLOW ALL INSTRUCTIONS
SAVE THESE INSTRUCTIONS

Table of Contents

SECTION I.	APPLICATION	2
SECTION II.	KIT CONTENTS	2
SECTION III.	HAND-HELD REMOTE	2
SECTION IV.	CONFIGURING BUTTONS	3
SECTION V.	INSTALLATION	4
SECTION VI.	CUSTOMIZING THE COMMUNICATION LINK	5
SECTION VII.	HAND-HELD REMOTE BATTERY REPLACEMENT	5
	TRUBLE-SHOOTING	6
	WARRANTY	7

WARNING



Risk of electrical shock or electrocution. It is required that the main power into the home be switched off at the main circuit breaker box.

WARNING

Before installing this product, read and follow all warning notices and instructions which are included. Failure to follow safety warnings and instructions can result in severe injury, death, or property damage. Call (800) 831-7133 for additional free copies of these instructions.

Important Notice



Attention Installer.

This manual contains important information about the installation, operation and safe use of this product. This information should be given to the owner/operator of this equipment.

Pentair Pool Products

1620 Hawkins Ave., Sanford, NC 27330 • (919) 774-4151
 10951 West Los Angeles Ave., Moorpark, CA 93021 • (805) 523-2400



Because **reliability** matters most

SECTION I. APPLICATION

Used in conjunction with the IntelliTouch Pool/Spa Control System.

Provides switching of four remote control circuits from a wireless Hand-held Remote.

It is typically used for activating the spa circulation, and for operating three auxiliary pieces of equipment (such as lights, jet pump, air blower, waterfall, etc.).

Each of the four functions on the Hand-held Remote has an "ON" and an "OFF" button.

SECTION II. KIT INCLUDES:

- 1-qty. Hand-held Remote (P/N 520018)
- 1-qty. Receiver (with 9½ ft. cable)
- 4-qty. Plastic Anchors (for mounting Receiver to concrete or stucco walls)
- 4-qty. Mounting screws (for mounting Receiver to a flat surface)

SECTION III. HAND-HELD REMOTE

The Hand-held Remote will control four circuits.

Although the Remote is capable of duplicating any four circuits, it has been preset at the factory to control the following:

Spa Push-button activates the Spa circuit.

"A" Push-button activates Auxiliary 1 circuit.

"B" Push-button activates Auxiliary 2 circuit.

"C" Push-button activates Auxiliary 3 circuit.

If you would like to control circuits other than Spa, Aux1, Aux2 and Aux3, it is possible to make adjustments through the Indoor Control Panel or MobileTouch.

USING THE HAND-HELD REMOTE

To activate a circuit, press and hold the appropriate "ON" button for at least *a full second*. To deactivate, press and hold the OFF button in the same manner.

IMPORTANT

The Hand-held Remote may be used with wet hands, but should never be submersed in water, as this could damage the unit. If accidental submersion occurs, dry unit out by removing battery cover and removing battery. Position unit so that water can drain out. Reassemble when completely dry.

SECTION IV. CONFIGURING BUTTONS

Configuring the Buttons of the 4-Function QuickTouch Wireless Hand-held Remote to control your desired functions

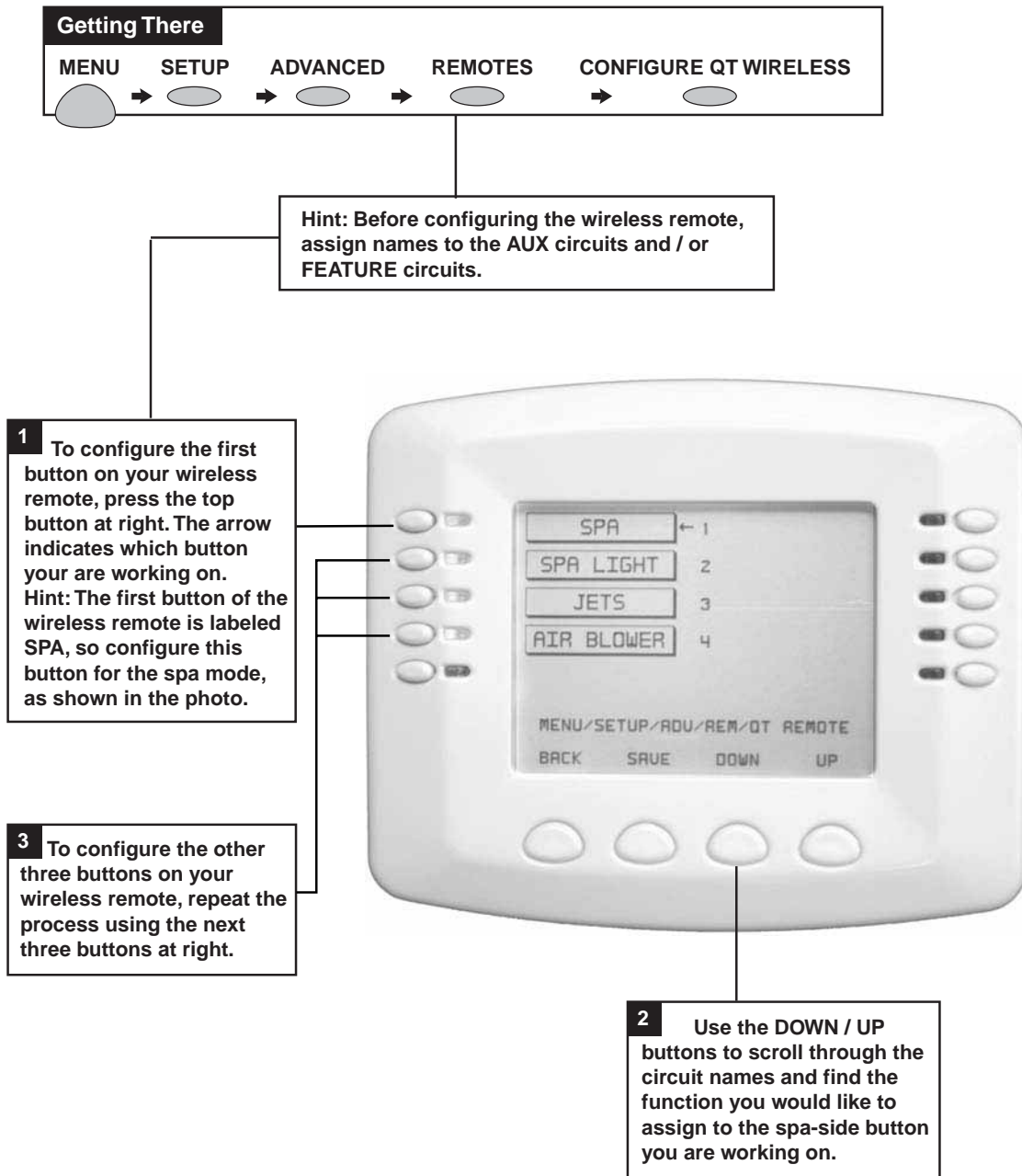

SECTION V. INSTALLATION

Receiver

The functional range of the wireless remote (from Hand-held Remote to Receiver) is approximately 150 ft. line-of-sight.

The receiver should be mounted at a convenient location (on a flat vertical surface) a minimum of 5 ft. above ground level to optimize the functional range of the hand-held unit. See Figure 1 for major features.

CAUTION

The receiver should be mounted a minimum of 8 to 10 feet away from any air blower, which may be part of the equipment set. The receiver will not operate properly if it is close to a blower that is operating.

1. In order to mount the receiver, it will be necessary to remove the two retaining screws located on the underside of the transceiver, and carefully slide the transceiver case up and off of its back plate.
2. Temporarily position the back plate against its mounting surface so that the receiver is oriented in an upright position (with antenna pointing upwards).
3. The circuit board will need to be temporarily removed. Slide the board up and out of the back plate. Use a pencil to mark the four mounting points, and drill 3/16 in. dia. holes. Insert the four plastic anchors (provided).
4. Feed a UL approved four 22AWG conductor cable through one of the drain holes at the bottom of the receiver enclosure. The preferred wire color scheme is: red, yellow, green, and black. If the drain holes are not used, drill a hole through the bottom of the back plate and seal using a fitting with a few feet of conduit or some other sealant between the case and the cable.
5. Reposition the back plate over the mounting points and secure with the four mounting screws (provided).
6. Strip the leads of the wires about 1/4 in. and attach to controller screw terminals of terminal plug as shown in Figure 2. Carefully slide the circuit board back into the back plate and connect the terminal plug.
7. Then slide the Receiver case back onto the back plate, and secure using the two retaining screws.

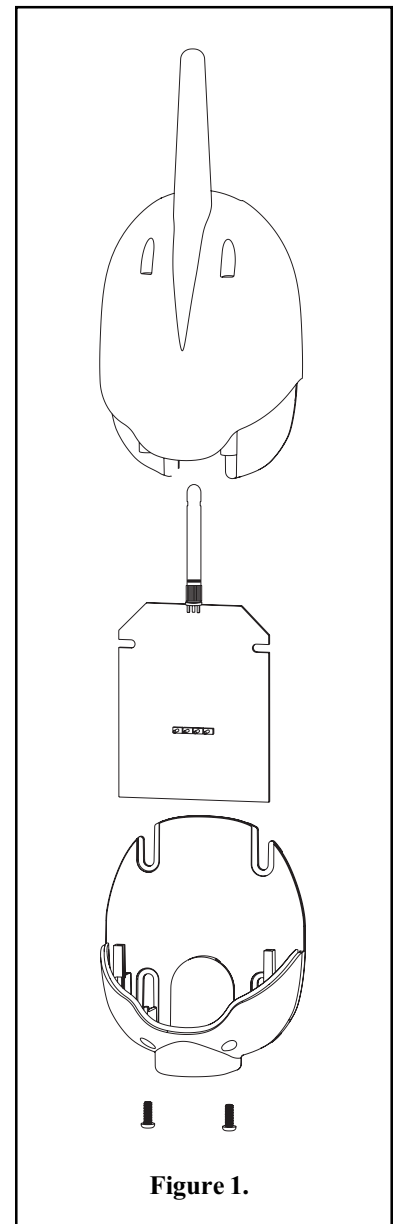

Figure 1.

CAUTION

Water damage may occur if the enclosure retaining screws are not secured or a new hole is drilled for the cable and not sealed. Do not seal drain holes.

Load Center

Feed the four conductor cable from the receiver up the low voltage raceway. Open the control panel and fold down to make connections. To the left of the board are the COM PORT connector(s). Strip the leads of the wires about 1/4 in. and attach to controller screw terminals of any COM PORT terminal plug following the wiring diagram.

Close control panel, high voltage cover panel, and Load Center door. Turn power to system back on.

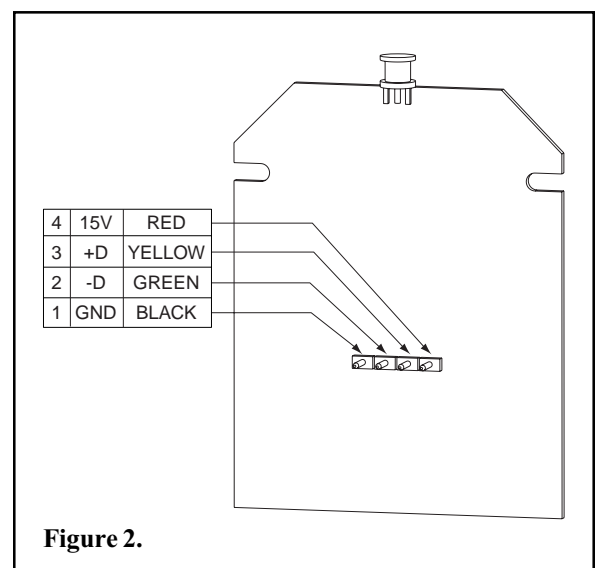
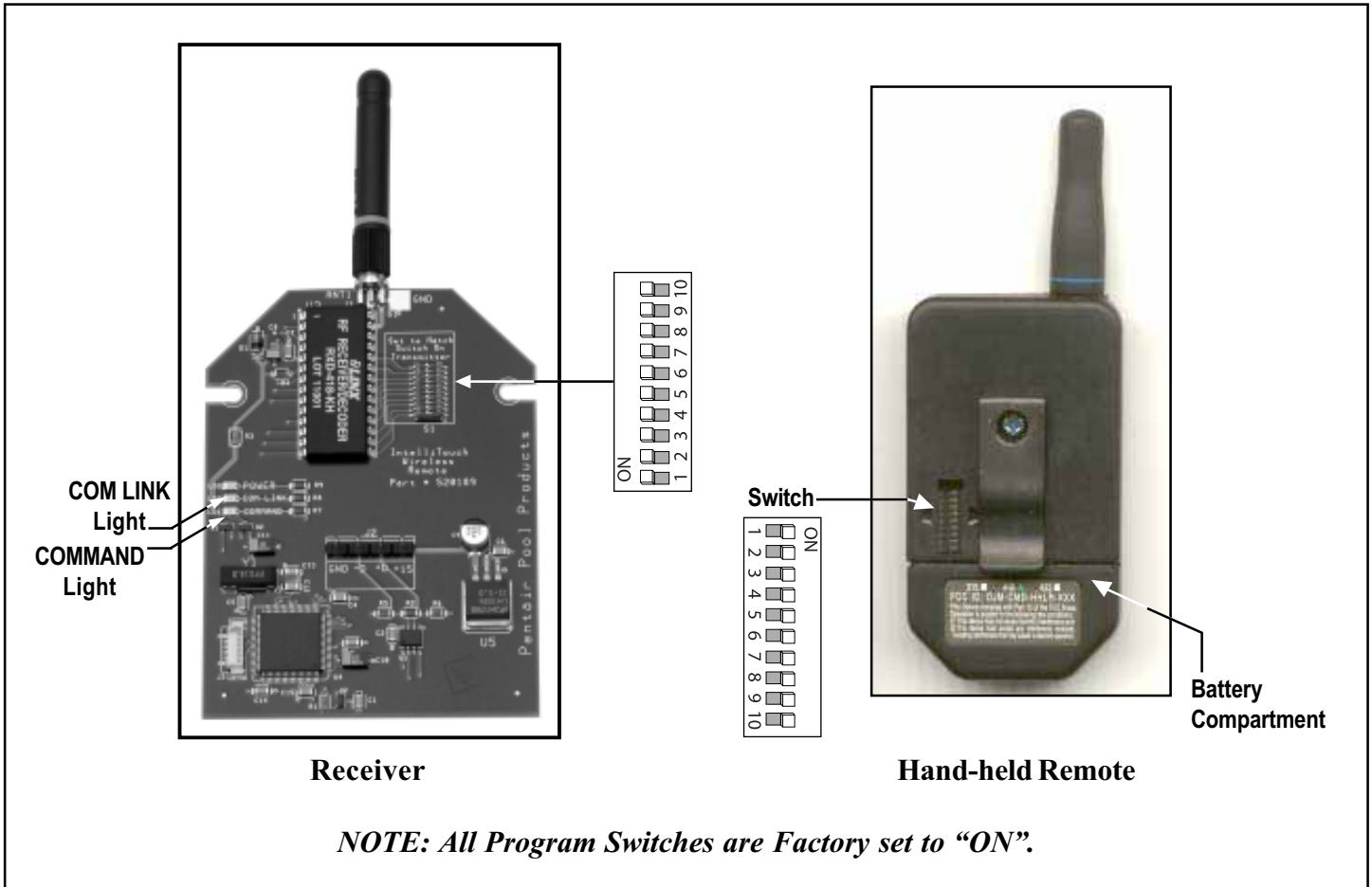

Figure 2.

SECTION VI. CUSTOMIZING THE COMMUNICATION LINK

The communication link between the Receiver and Hand-held Remote can be customized to prevent electrical interference. To accomplish this, there is a 10-position configuration switch located on the Receiver circuit board, and inside the Hand-held Remote. Units are shipped from the factory with all switches in the ON position.

If you wish to change this setting, use a paper clip or other blunt instrument and adjust both 10-position configuration switches to matching settings. If the configuration switch setting at the Receiver does not match that of the Hand-held Remote the communication link will not function.



If the IntelliTouch system has not been set to a new house address you should do so now. To set a new House Address consult the main system instructions. The Load Center System Control lights will blink repeatedly when a house address is being sent out.

If the system is sending a new house address, the COM LINK and COMMAND lights will blink together repeatedly on the QT4 board.

If the system is sending an existing house address, the COM LINK and COMMAND lights will blink alternately.

While this is happening press any button of the Hand-held Remote. The COM LINK and COMMAND lights will blink alternately. The main system may now be RESET. Wait for Auto Mode and the QT4 lights to stop blinking before resuming normal operation.

SECTION VII. HAND-HELD REMOTE BATTERY REPLACEMENT

With normal use the battery should last for several years. In the event the battery must be replaced, slide the cover from the bottom of the Hand-held Remote. Slide the battery from the retainer clip and discard in accordance with local and/or state ordinances. Replace with 3V lithium battery number CR2032 or equivalent. Slide battery cover onto remote and snap in place.

TROUBLE-SHOOTING

Symptom	Possible Cause	Solution
POWER LED does not light.	Load Center does not have power. Defective cable or connection to the Load Center. Defective receiver board.	Insure power is being supplied and that the Load Center operates correctly without the receiver installed. Verify the function of the board using known good cable set. Contact factory or service center.
COM LINK LED does not light or blink. In normal operation LED will blink at least every 2 seconds.	Defective cable or connection to the Load Center. Defective receiver board.	Verify the function of the board using known good cable set. Contact factory or service center.
COMMAND LED does not light when Hand-held Remote button(s) is pressed - unit fails to operate.	Address switches are incorrectly configured. Hand-held Remote battery has failed. Defective Hand-held Remote or receiver.	Verify that the address switches on the Hand-held Remote and receiver board are correct and match. Replace Hand-held Remote battery. Contact factory or service center.
Unit functions, but some circuits do not work, or operate the incorrect circuit.	Circuit selections incorrectly configured.	Verify settings at Control Panel: MENU/SETUP/ADV/REM/QT REMOTE
Unit fails to operate, or fails to operate dependably at range.	Undue electrical noise. Too many obstructions between the Hand-held Remote and receiver. Receiver unit is too near the ground.	Relocate the receiver away from equipment such as blower motors. Relocate the receiver in a location that provides fewer obstructions to the area the user commonly operates the Hand-held Remote. Relocate the receiver to maximize the distance between the receiver antenna and the ground.
Unit seems to turn on or off circuits without the user / Hand-held Remote.	A nearby home is operating a similar wireless unit.	Select an alternate address code for the Hand-held Remote and receiver. <i>/i.e.</i> change the switches on both boards to an alternate, but matching setting.
Unit dependably turns equipment ON, but once equipment is running it does not dependably turn equipment OFF, or range is greatly reduced when equipment is running.	Undue electrical noise is being produced by one or more pieces of equipment in close proximity to the receiver.	Relocate the receiver away from equipment such as blower motors. Relocate the receiver in a location that provides fewer obstructions to the area the user commonly operates the Hand-held Remote.
Unit operates, but has greatly reduced range compared to prior function.	Hand-held Remote battery is failing.	Replace Hand-held Remote battery.

For questions, repairs, replacement parts, or information on possible Authorized Service Centers within your vicinity call:

Pentair Pool Products ~ 800-831-7133

Or visit us on the Internet at **www.pentairpool.com**

Pentair Pool Products

1620 Hawkins Ave., Sanford, NC 27330 • (919) 774-4151

10951 West Los Angeles Ave., Moorpark, CA 93021 • (805) 523-2400



Because reliability matters most