



Model Number

IQH1-18GM-V1

Read/write head
for IDENTControl

Features

- Operating frequency 13.56 MHz
- Conforms to ISO 15693
- Suitable for FRAM transponder
- Read/write head with thread M18 x 1
- Connection via V1 (M12 x 1) plug connection
- Multihole-LED for function display
- Degree of protection IP67

Dimensions

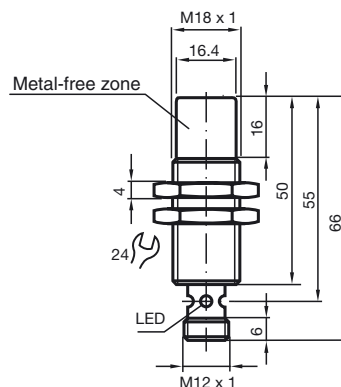

Electrical connection

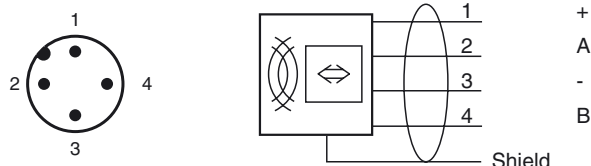

Technical data

General specifications

Operating frequency	13.56 MHz
Transfer rate	26 kBit/s
Sensing range	
Read distance	0 ... 55 mm
Write distance	0 ... 55 mm
Width	max. 45 mm
UL File Number	E87056 only from low voltage, limited energy source (SELV or PELV) or listed Class 2 source

Indicators/operating means

LED green/yellow	Multihole-LED: green: power on green flashing: read/write attempt performed yellow: data carrier detected
------------------	--

Electrical specifications

Power consumption	P_0	≤ 1.2 W
Supply		from the IDENTControl

Ambient conditions

Ambient temperature	-25 ... 70 °C (-13 ... 158 °F)
Storage temperature	-40 ... 85 °C (-40 ... 185 °F)

Mechanical specifications

Degree of protection	IP67
Connection	M12 x 1 connector
Material	
Housing	PBT/stainless steel
Encapsulation compound	CY 221/HY 2966
Installation	non-flush
Distance between two heads	Multiplex on: ≥ 30 mm Multiplex off: ≥ 80 mm
Mass	approx. 40 g

Compliance with standards and directives

Directive conformity	
R&TTE Directive 1995/5/EC	EN 301489-1 V1.8.1 (2008-04), EN 301489-3 V1.4.1 (2002-08), EN 300330-2 V1.3.1 (2006-04), EN 60950-1:2006
Standard conformity	
Electromagnetic compatibility	EN 61000-6-2:2006 , EN 61000-6-4:2007
Degree of protection	EN 60529:2000
RFID	ISO/IEC 15693-2:2006 , ISO/IEC 15693-3:2009 , ISO/IEC 18000-3:2008

Approvals and certificates

FCC approval

This device complies with part 15 of the FCC rules. Operation is subject to the following two conditions:

- (1) This device may not cause harmful interference, and
- (2) This device must accept any interference received, including interference that may cause undesired operation.

Caution:

Changes or modifications not expressly approved by the party responsible for compliance could void the user's authority to operate the equipment.

Notes

This equipment has been tested and found to comply with the limits for a Class A digital device, pursuant to part 15 of the FCC Rules. These limits are designed to provide reasonable protection against harmful interference when the equipment is operated in a commercial environment. This equipment generates, uses, and can radiate radio frequency energy and, if not installed and used in accordance with the instruction manual, may cause harmful interference to radio communications. Operation of this equipment in a residential area is likely to cause harmful interference in which case the user will be required to correct the interference at his own expense.

Accessories**IQC21-50P**

Data carrier

IQC21-58

Data carrier

IQC22-C5

Data carrier

IQC33-20

Data carrier

IQC33-30

Data carrier

IQC33-50

Data carrier

V1-G-5M-PUR-ABG-V1-W

Connecting cable, M12 to M12, PUR cable 4-pin, shielded

V1-G-10M-PUR-ABG-V1-W

Connecting cable, M12 to M12, PUR cable 4-pin, shielded

IQC24-27-T12

Data carrier

IQC31-22-T9

Data carrier

IQC22-22CT-T9

Data carrier

IQC22-C1 UNPRINTED

Data carrier