



MPU5

BASIC OPERATOR MANUAL

VERSION 2.0



Copyright 2010 - 2016 Persistent Systems, LLC. Wave Relay® is a registered trademark of Persistent Systems, LLC. All rights reserved. This Basic Operator Manual contains information that is the sole property of Persistent Systems, LLC and may not be excerpted, summarized, copied or published without the written permission of Persistent Systems, LLC.



READ MANUAL BEFORE OPERATION

Copyright 2010 - 2016 Persistent Systems, LLC
Issued: January, 2016

PERSISTENT SYSTEMS

Headquartered in New York City since 2007, Persistent Systems LLC is a global communications technology company which develops, manufactures and integrates a patented and secure Mobile Ad Hoc Networking (MANET) system: Wave Relay®. The company's industry-leading R&D team has designed wireless networking protocols to support their cutting edge Wave Relay® system and has designed MIMO radios to allow the Wave Relay® MANET to achieve its highest potential. Wave Relay® is capable of running real-time data, video, voice and other applications under the most difficult and unpredictable conditions. Their suite of products is field proven and utilized in Commercial, Military, Government, Industrial, Agriculture, Mining, Oil and Gas, Robotics, and Unmanned System markets.

THE MPU5

The MPU5 is the Next Generation Wave Relay® platform. Leveraging multiple leading edge technologies such as MIMO and Android™, the MPU5 is a smart radio that delivers increased performance, reliability, and capability to the end user in a small, cost-efficient package. Stream multiple HD Video feeds, run commercial and custom apps, view situational awareness, and communicate with high quality audio all with a single device and a minimal number of accessories.

WAVE RELAY® MANET

The Wave Relay® System is a peer-to-peer wireless MANET networking solution in which there is no master node. If any device fails, the rest of the devices continue to communicate using any remaining connectivity. By eliminating master nodes, gateways, access points, and central coordinators from the design, Wave Relay® delivers high levels of fault tolerance regardless of which nodes might fail. The

system is designed to maximize the capacity of the radio frequency (RF) spectrum and to minimize the network overhead. While optimizing efficiency, Wave Relay® also implements techniques that increase multicast reliability. The advanced multicast functionality allows the system to support both multicast voice and video over IP.

Wave Relay® is designed to maintain high bandwidth connectivity among devices that are on the move. The system is scalable, enabling it to incorporate unlimited meshed devices into the wireless network, where the devices themselves form the communication infrastructure. Even in highly dynamic environments, the system is able to maintain connectivity by rapidly re-routing data as necessary. Wave Relay® is a self-forming and self-healing network where nodes can move freely within the network. Critical information flows reliably throughout the network while individual data paths are able to adapt at sub-second intervals. This unique approach creates an ideal environment for maximizing performance across the available communications medium. Customers leverage Wave Relay®'s straight forward and effective architecture to enable a true "Plug and Play" capability. Deploying a Wave Relay® network is as simple as connecting a standard Ethernet cable; customers are immediately connected to everything on the network.

Wave Relay® is a seamless wireless networking system offering a dynamic and reliable solution for all mobile networking needs. The MPU5 offers the Wave Relay® MANET combined with other leading edge technologies in a single smart radio.

Introduction	4
Persistent Systems	4
The MPU5	4
Wave Relay® MANET	4
Safety	12
Suggested Hardware	16
Part I: Physical Setup	17
Section A: RF Setup	17
Inserting the Radio Module	20
Connecting Antennas	22

Section B: Power	26
Connecting Power	28
Removing Power	30
Powering On the Unit	32
Section C: Side Connector Cables	34
Parts List/Interchangeable Parts	35
Connecting a Cable to a Side Connector	36
Part II: Software Setup	40
Section A: Configuring the Management Computer	40
Parts List/Interchangeable Parts	40
Configuring the Management Computer (Windows)	42

Configuring the Management Computer (Linux)	50
Connecting the MPU5 to the Management Computer	51
Parts List/Interchangeable Parts	51
Accessing the Web Management Interface	51
Parts List/Interchangeable Parts	54
Security Key	62
Assigning IP Address and Interface Names	64
Rebooting an Individual Node	67
Part III: Testing Connectivity	68
Check Neighbor Node Status	68
Perform a Throughput Test	70

Part IV: Using the Web Management Interface	72
View Individual Node Information	72
Configuring Radio Settings for a Single Node	74
Upgrading Firmware	76
Creating a Configuration File	78
Loading Settings from a Configuration File	79
Reset Node to Factory Configuration	80
Check GPS Status	81
Part V: Device Operation	82
Zeroize the Security Key	82
Connect a Camera to the MPU5	84

TABLE OF CONTENTS

Connect an EUD or Handheld Display to the MPU5	86
Connecting a Monitor or TV to the Wave Relay® MPU5	88
Connect USB Accessories to the MPU5	91
Install Android™ Apps on the MPU5	93
Connect a PTT Device to the MPU5	98
Configure PTT Settings	100
Enable Push-to-Talk	101
Set Earpiece Volume	101
Set Microphone Level	102
Set Transmit Mode	103
Set Transmit or Receive Audible Checktone	104

Enable/Disable Low Battery Audible Notification	105
Selecting Channels	106
Customize a PTT Channel	107
Using Wave Relay® Push-to-Talk	108
Using Flash Override	109
Professional Installer – Compliance	110
Attachments	114



Lire et comprendre les consignes de sécurité d'emploi et tout de l'opérateur avant d'utiliser cet équipement

SAFETY WARNINGS

Handle Safely:



- Falling while installing or removing equipment can cause serious injury.
- If installing on a tower or any other tall locations, use proper lifting techniques and wear proper protective equipment.
- Tomber lors de l'installation ou de retirer l'équipement peut causer des blessures graves.
- Si vous installez sur une tour ou d'autres endroits de hauteur, utiliser des techniques de levage appropriées et porter un équipement de protection approprié.

Electrical Shock and Fires:



RF Exposure:



- Understand and follow all local codes and regulations when installing electrical equipment.
- Only use approved battery and/or power supplies.
- Comprendre et respecter tous les codes et règlements locaux lors de l'installation des équipements électriques.
- Utilisez uniquement la batterie et les alimentations ou approuvé.
- Prevent injury from exposure to high frequency fields.
- See antenna separation instructions in the Compliance section of this manual.
- Do not operate with antenna removed. This can increase RF exposure risks and/or damage the equipment.
- Prévenir les blessures d'exposition aux champs de haute fréquence.
- Voir les instructions de séparation de l'antenne dans la section de la conformité de ce manuel.
- Ne pas faire fonctionner avec antenne enlevé. Cela peut augmenter les risques d'exposition aux radiofréquences et ou endommager l'équipement.

CAUTION
DEVICE UTILIZES LITHIUM ION BATTERY
RISK OF EXPLOSION IF BATTERY IS REPLACED BY AN INCORRECT TYPE.
DISPOSE OF USED BATTERIES ACCORDING TO THE INSTRUCTIONS

MISE EN GARDE
Dispositif utilise la batterie Ion Lithium
RISQUE D'EXPLOSION SI LA BATTERIE EST REMPLACÉ PAR UN TYPE INCORRECT.
Jetez les piles usagées selon
LES INSTRUCTIONS

Lithium Batteries Handling

- Lithium ion batteries are defined as Class 9 dangerous goods by the IATA Dangerous Goods Regulations.
- Handle with care.
- Do not use if package is damaged - it can cause fire.

Disposing of Used Batteries

- Disposal should be done in accordance with applicable regulations, which vary from country to country as well as by state and local governments. In most countries, trashing of used batteries is forbidden and disposal can be done through non-profit organizations mandated by local au-

thorities or organized by professionals.

- Incineration of lithium cells and batteries by consumers is not recommended. Incineration should be done at a properly permitted facility that can handle this waste.
-

Manipulation des batteries lithium

- Les batteries au lithium-ion sont définies comme Classe 9 marchandises dangereuses par le Règlement sur les marchandises dangereuses de l'IATA.
- Manipuler avec soin.
- Ne pas utiliser si l'emballage est dommage, il peut provoquer un incendie.

Mise au rebut des batteries usagées

- L'élimination doit être effectuée conformément aux réglementations applicables, qui varient d'un pays à l'autre ainsi que par les gouvernements d'État et locaux. Dans la plupart des pays saccage des batteries usagées est interdit et l'élimination peut être fait par les organisations à but non lucratif mandatés par les autorités locales ou organisées par des professionnels.
- Incinération des cellules et batteries au lithium par les consommateurs est déconseillée. Incinération devrait être fait dans une installation dûment autorisée qui peut gérer ces déchets.

See Attached Battery Spec Sheet, MSDS, and compliance document for more information

Suggested Additional Hardware

- ▶ **Torque Wrench:** Used to attach/detach radio module
- ▶ **TPI Kit:** Allows for antenna and RF cable matching
- ▶ **RF cable at various lengths (LMR-400):** Allows for flexibility in antenna setup
- ▶ **Ethernet Cables**
- ▶ **Ethernet Female-to-Female Extenders**
- ▶ **HD Screen or TV with HDMI input:** Displays Android™ computer interface and/or streaming video
- ▶ **Laptop with Administrator Access:** Used for device configuration
- ▶ **USB Thumb Drives:** Used for software configuration storage and loading

Part I: Physical Setup

Section A: Power

What Will I Learn?

- ▶ How to attach antennas to the MPU5
- ▶ How to insert radio modules into the MPU5 chassis

PHYSICAL SETUP: RF SETUP





WARNING!: User **MUST** refer to the **Professional Installer – Compliance** Section of this manual for approved antenna types.



How do I tell if my antennas and radio modules are compatible?

- 1 Find the part numbers on the antennas. Antenna part numbers are on a sticker wrapped around the base of the antenna.
- 2 Find the part number on the radio module. The radio module part number is on a sticker on the back of the radio module.
- 3 Each part number will begin with ANT- (antennas) or RF- (radio modules) followed by four (4) digits. The first digit references the radio band of the part. Make sure that the first digit of the antennas and radio module match.

Quick Reference:

ANT- or RF-1xxx – L-Band (1.35 - 1.39 GHz)

ANT- or RF-2xxx – S-Band (2.2 - 2.5 GHz; EDM: 2.3 - 2.5 GHz)

ANT- or RF-3xxx – C-Band (4.4 - 4.8 GHz or 4.9 - 5.8 GHz) *in development



WARNING!: DO NOT use mismatched antennas and radio modules. This configuration will result in very poor performance if it works at all. If you do not have matching antennas and radio modules, contact Persistent Systems.

Inserting the Radio Module

- 1** If there are **rubber caps** on the radio module contacts, **remove** them.
- 2** **Align** the radio module with the chassis.
- 3** **Press** the radio module into the chassis.

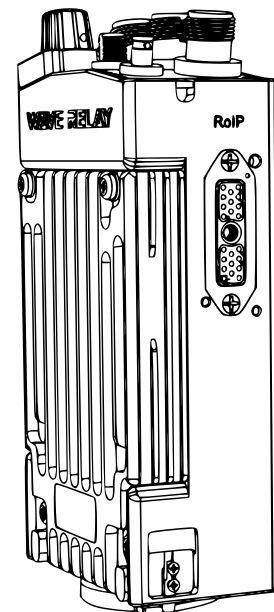
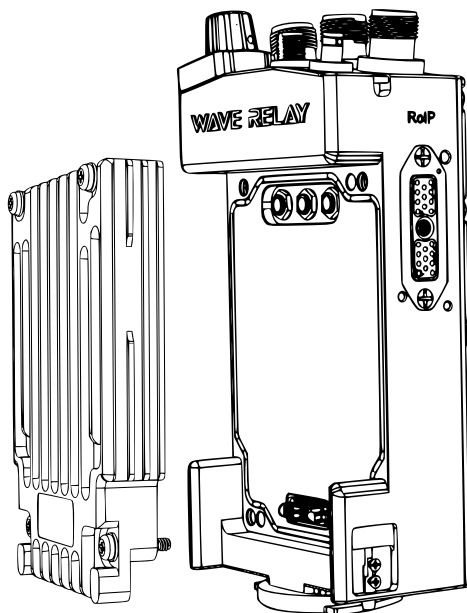
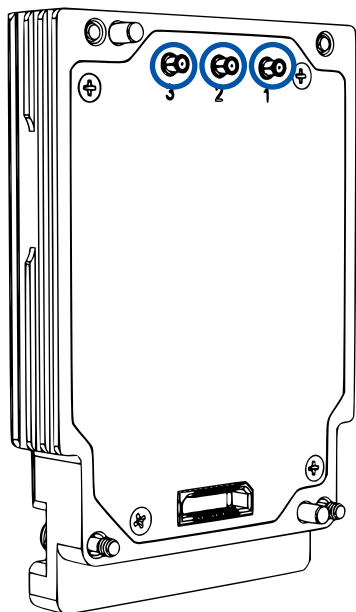

- 4** Torque screws clockwise to **6 in lbs** in **diagonal** order.

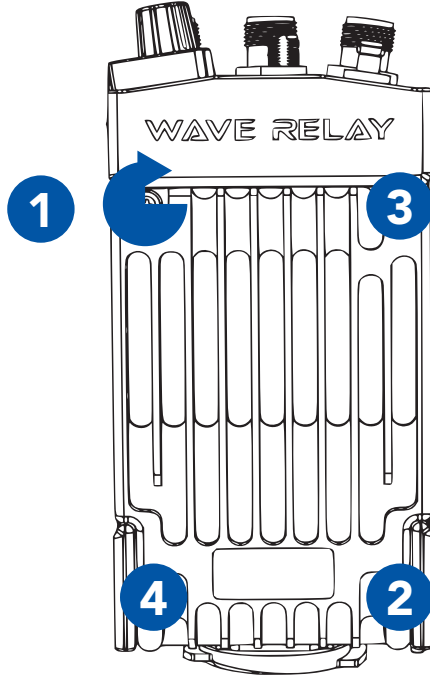

- 5** Pull on the radio module to verify that it is attached securely.

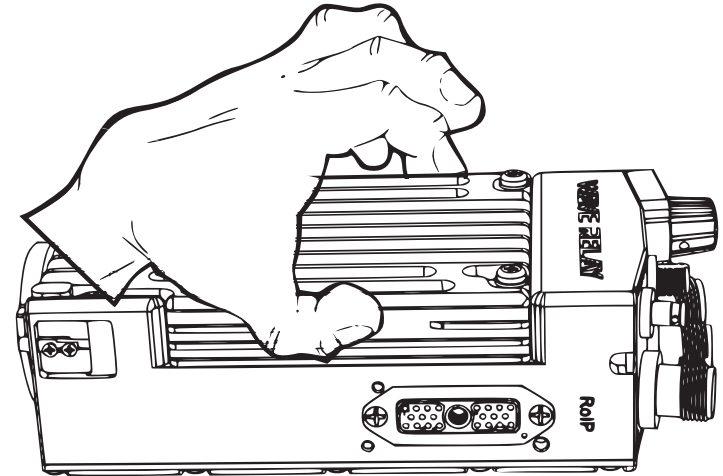

Connecting Antennas

- 1 Start with the **middle** antenna port.

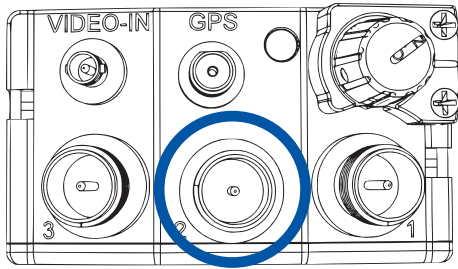

- 2 Align the **RF connector** on the antenna with the **RF connector** on the unit.

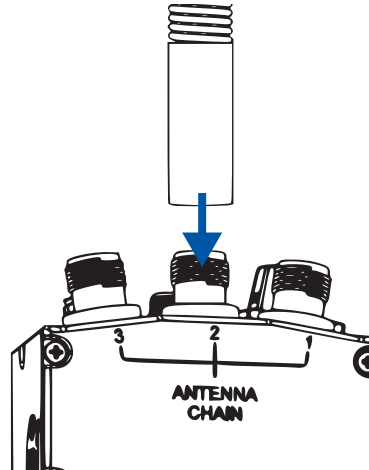

- 3 **Twist** the antenna clockwise until it is fully mated.

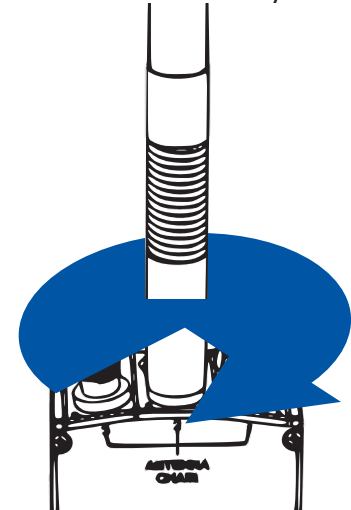

Tips & Tricks

- ▶ You can use a TPI Kit and/or extra LMR-400 RF Cables to remote antennas away from the unit. This setup is particularly useful for mounted or operations center configurations.
- ▶ To operate in SISO mode, you only need to attach an antenna to the antenna port for the chain you want to use.

! **WARNING!:** if you want to operate in SISO mode, unused antenna chains **MUST** be turned off.

- 4** Repeat **Steps 1 - 3** for the remaining two RF antennas.

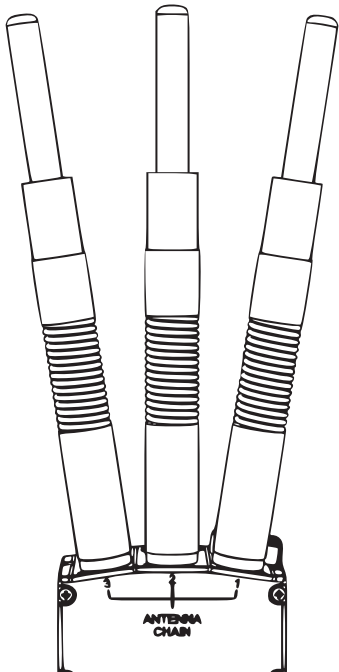

- 5** Align the **SMA connector** on the GPS antenna with the **SMA connector** on the unit.

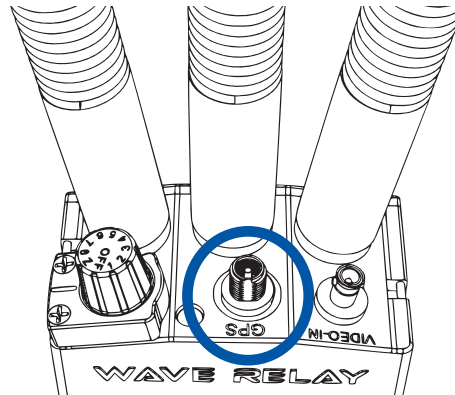

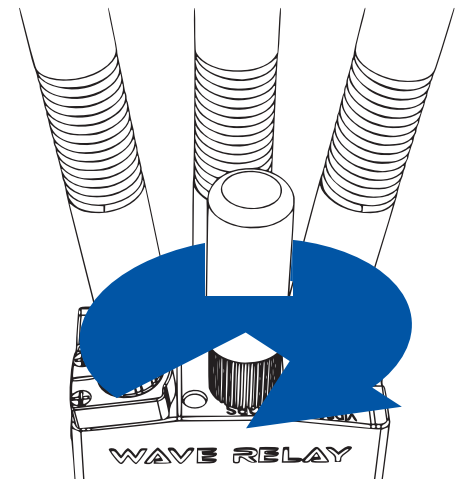

- 6** **Twist** the antenna clockwise until it is fully mated.





How do I ensure that the radio module is aligned properly?

The three RF connectors on the radio module will align with the three RF connectors on the chassis. When aligned properly, the engraved writing on the radio module will be facing the same direction as the writing on the chassis.

What do I do if the antennas won't screw onto the RF connectors?

-  Ensure that you are using antennas with RP-TNC Male connectors or an appropriate adapter from your TPI kit.
-  Ensure that the connectors on both the unit and antennas are not damaged.
-  Ensure that there are no foreign objects in any of the connectors.

What do I do if the radio module won't insert into the chassis?

-  Ensure that the radio module is aligned properly.
-  Ensure that the connectors on the radio module are not bent.
-  Ensure that there are no foreign objects in any of the connectors, on the bottom of the radio module, or in the chassis well.

How do I tell if the antennas are connected properly?

-  When an antenna is mated properly, the threads on the connector will not be visible. However, there may be a small space between the antenna and the chassis.

What Can I Do Now?

- ▶ Swap radio modules and antennas to change the RF band you are capable of operating on
- ▶ Swap out broken radio modules and antennas
- ▶ Setup hardware to receive GPS connectivity
- ▶ Remote antennas away from the unit

Section B: Power

What Will I Learn?

- ▶ How to connect a power source to the MPU5
- ▶ How to power on the MPU5

How can I use my old power accessories from previous Wave Relay products with my MPU5?

You can use your MPU4 twist locking battery pack or BB batteries with the MPU5. You CANNOT use old battery eliminators with the MPU5. The MPU5 accepts 12 - 24V input power, unlike previous Wave Relay® products. You CANNOT power the MPU5 via Power over Ethernet (PoE).

