

PAD07 In Wall Smart Dimmer



Built-in High Breaking Capacity current fuse protection. Rating : 2A /250V.
Built-in Thermal Cutoff Fuses protection. Rated Temperature :125 °C; Rating : 2A /250V.

PAD07 is a security enabled wireless dimmer, based on Z-Wave Plus technology. Z-Wave Plus™ enabled devices displaying the Z-Wave Plus™ logo can also be used with it regardless of the manufacturer, and can also be used in other manufacturer's Z-Wave™ enabled networks. You can On/Off the light by pressing the button briefly, or a long pressing to control the brightness of dimmable light bulb.

Warning: Do not use Non-Dimmable LED lamps.

This dimmer is a transceiver which is a security enabled device which based on Z-Wave Plus technology, and it is fully compatible with any Z-Wave™ enabled network. Since PAD07 supports Security Command Class, it can learn with Secured controller. Its functionality and supported command classes is identical when included as a secure and non-secure device.

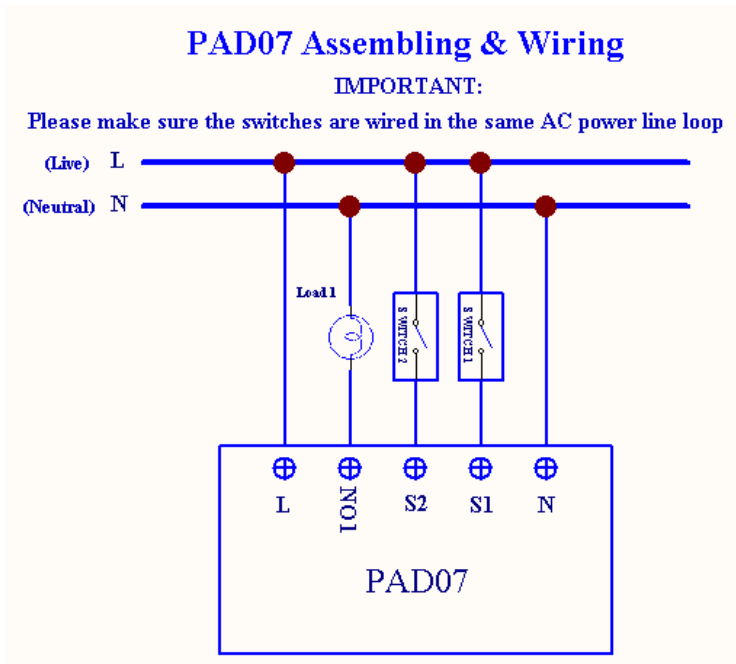

Adding to Z-Wave™ Network

In the front casing, there is an on/off button (also an include button) with LED indicator below which is used to dim on and off or carries out inclusion, exclusion, reset or association. When first power applied, its LED flashes on and off alternately and repeatedly at 0.5 second intervals. It implies that it has not been assigned a node ID and start auto inclusion.

Auto Inclusion

The function of auto inclusion will be executed as long as the dimmer does not have Node ID and just connect the switch to main power.

Note: Auto inclusion timeout is 2 minute during which the node information of explorer frame will be emitted once every several seconds. Unlike “inclusion” function as shown in the table below, the execution of auto inclusion is free from pressing the

Fig 1. Assembling & Wiring

On/Off button on the dimmer.

The table below lists an operation summary of basic Z-Wave functions. Please refer to the instructions for your Z-Wave™ Certificated Primary Controller to access the Setup function, and to Add/Remove/associate devices

Function	Description	Annotation
No node ID	The Z-Wave Controller does not allocate a node ID to the Switch.	LED 2-second on, 2-second off
Add (Inclusion)	1. Put your Z-Wave controller into inclusion mode by following the instructions provided by the controller manufacturer.	
	2. Pressing Include button of PAD07 three times within 2 seconds will enter inclusion mode.	
Remove (Exclusion)	1. Put your Z-Wave controller into exclusion mode by following the instructions provided by the controller manufacturer.	
	2. Pressing Include button of PAD07 three times within 2 seconds will enter exclusion mode.	
	3. Node ID has been excluded.	

Reset	1. Pressing Include button of PAD07 three times within 2 seconds will enter inclusion mode.	Use this procedure only in the event that the primary controller is lost or otherwise inoperable.
	2. Within 1 second, press Include button of PAD07 again for 5 seconds.	
	3. IDs are excluded.	0.5s On, 0.5s Off (Enter auto inclusion)
Association	1. The PAD07 is an always listening Z-Wave device, so associations may be added or removed by a controller at any time. Or If your controller requires to have the PAD07 send a 'node information frame' or NIF for associations, then pressing the On/Off button three times within 2 seconds will cause the PAD07 to send its NIF.	
	2. There is only one group for the dimmer	
<p>✘ Adding a node ID allocated by Z-Wave Controller means inclusion. Removing a node ID allocated by Z-Wave Controller means exclusion.</p> <p>✘ Failed or success in including/excluding the node ID can be viewed from the Z-Wave Controller.</p>		

LED Indication

To distinguish what mode the switch is in, view from the LED for identification.

State Type	LED Indication
Normal	Whenever we switch On and off of the PAD07 by On/Off button or RF command, the LED will lights up when switch on; whereas LED off when switch off.
No node ID	Under normal operation, when the Switch has not been allocated a node ID, the LED flashes on and off alternately at 2-second intervals. By pressing On/Off button, it will stop flashing temporarily.
Learning	When PAD07 is in learning mode, LED flashes on and off alternately and repeatedly at 0.5 second intervals.

Choosing a Suitable Location

1. Do not locate the dimmer facing direct sunlight, humid or dusty place.
2. The suitable ambient temperature for the Switch is 0°C~40°C.
3. Do not locate the dimmer where exists combustible substances or any source of heat, e.g. fires, radiators, boiler etc.
4. After putting it into use, the body of dimmer will become a little bit hot of which phenomenon is normal.

Manual dim level control :

To manually switch on the light, press and release the On/Off button or S1/S2 shortly when the light is off. The light will dim from off to the level which was set before switch off. To manually switch off the light, press and release the On/Off button or

S1/S2 shortly when the light is on. To adjust the dim level, press and hold the On/Off button or S1/S2 until the desired dim level is achieved, then release.

Programming

1. Basic Command Class / Multilevel Switch Command Class

The dimmer will respond to BASIC and MULTILEVEL SWITCH commands that are part of the Z-Wave system. If PAD07 is included as a secured node, it will only response to the security encapsulation command of BASIC and MULTILEVEL SWITCH.

1-1 BASIC_GET / MULTILEVEL_SWITCH_GET

Upon receipt of the following commands from a Z-Wave Controller, the Switch will report its dimmer state to the node inquired.

Basic Get Command: [Command Class Basic, Basic Get]
--

Basic Report Command:

Report OFF: [Command Class Basic, Basic Report, Value = 0]

Report ON: [Command Class Basic, Basic Report, Value = 1~99]

Multilevel Switch Get Command: [Command Class Multilevel Switch, Multilevel Switch Get]
--

Multilevel Switch Report Command:

Report OFF: [Command Class Multilevel Switch, Multilevel Switch Report, Value=0]

Report ON: [Command Class Multilevel Switch, Multilevel Switch Report, Value =1~99]
--

1-2 BASIC_SET / MULTILEVEL_SWITCH_SET

Upon receipt of the following commands from a Z-Wave Controller, the load attached to the dimmer will turn on or off.

[Command Class Basic, Basic Set, Value = 0] : the load attached to the dimmer turns off.

[Command Class Basic, Basic Set, Value = 1~99] : the attached load dim on as the level.

[Command Class Multilevel Switch, Multilevel Switch Set, Value=0, Duration = 0~255] : the load attached to the dimmer turns off.

[Command Class Multilevel Switch, Multilevel Switch Set, Value =1~99, Duration = 0~255] : the attached load dim on as the level.

1. Z-Wave's Groups (Maximum 5 nodes)

The Switch can be set to send reports to associated Z-Wave devices. It supports one association group with five nodes support for grouping 1. For group 1, the dimmer will report MULTILEVEL_SWITCH_REPORT, ALARM_REPORT and DEVICE_RESET_LOCALLY_NOTIFICATION.

2-1 Auto report to Grouping 1

2-1-1 On/Off Event Report

When "on" or "off" state has been changed, it will send Multilevel Switch Report to the nodes of Grouping 1.

Multilevel Switch Report

ON:**[Command Class Multilevel Switch, Multilevel Switch Report, Value =1~99]**

OFF:**[Command Class Multilevel Switch, Multilevel Switch Report, Value =0(0x00)]**

2-1-2 Overload alarm report

When PAD07 detects the Overload, it will send Alarm Report to Group 1 nodes. After detecting overload state and sending this alarm report, PAD07 will turn off the dimmer automatically and lockout the On/Off button and S1/S2. The only thing to do is unplug PAD07 and reduce the load. Then re-power on PAD07 and it will work again.

The content of Alarm Report

Alarm report command: [Command_Class_Alarm, Alarm_Report, Alarm Type = 0x08, Alarm Level = 0xFF]

2-2 Send Basic Set to Grouping 1

When "on" or "off" state has been changed by manual key pressing, a Basic Set command will follow the Multilevel Switch Report send to the nodes of Grouping 1.

[Command Class Basic, Basic Set, Value = 0]

[Command Class Basic, Basic Set, Value = 1~99]

3. Z-Wave's Configuration

Configuration Parameter	Function	Size (Byte)	Value	Unit	Default	Description
1	Dimmer Level Report mode	1	0-1		1	0 : Disable 1 : Enable
2	LED indication mode	1	1-3		1	1: Show dimmer state 2 : Show night mode 3: One flash mode

3	External switch type	1	1-3		1	1 : One switch mode 2 : Two switch mode 3: Up/Down switch mode
4	Restore dimmer state	1	0-2		1	0 : Dimmer off 1 : Last dimmer state 2 : Dimmer on

3-1 Dimmer level report mode :

Whenever dimmer on/off state changes, it will send MULTILEVEL_SWITCH_REPORT to the nodes of group1. The default setting is Enable the function.

3-2 LED indication mode :

3-2-1 Show dimmer State : When dimmer is on, LED is on. When dimmer is off, LED is off. The default setting is Show dimmer State.

3-2-2 Show Night mode : When dimmer is on, LED is off. When dimmer is off, LED is on.

3-2-3 One flash mode : When dimmer on/off state changes, LED will light on one second and then off.

3-3 External switch type :

3-3-1 One switch mode : Only S1 can dim up the light bulb to brightest level, then dim down to darkest level, and so on...

3-3-2 Two switch mode : S1 and S2 can dim up the light bulb to brightest level, then dim down to darkest level, and so on...

3-3-3 Up/Down switch mode : S1 can only dim up the light bulb to brightest level, and S2 can only dim down to Off.

3-4 restore dimmer state :

Whenever the AC power return from lost, PAD07 will restore the switch state which

could be Dimmer off \ Last dimmer state \ Dimmer on. The default setting is Last dimmer state.

4. Firmware update over the air (OTA)

PAD07 is based on 500 series SoC and supports Firmware Update Command Class, it can receives the updated firmware image sent by controller via the Z-wave RF media. It is a helpful and convenient way to improve some function if needed.

5. Command Classes

The Switch supports Command Classes including...

- * COMMAND_CLASS_ZWAVEPLUS_INFO
- * COMMAND_CLASS_VERSION_V2
- * COMMAND_CLASS_MANUFACTURER_SPECIFIC_V2
- * COMMAND_CLASS_SECURITY
- * COMMAND_CLASS_DEVICE_RESET_LOCALLY
- * COMMAND_CLASS_ASSOCIATION_V2
- * COMMAND_CLASS_ASSOCIATION_GRP_INFO
- * COMMAND_CLASS_POWERLEVEL
- * COMMAND_CLASS_BASIC
- * COMMAND_CLASS_SWITCH_MULTILEVEL_V2
- * COMMAND_CLASS_CONFIGURATION
- * COMMAND_CLASS_ALARM
- * COMMAND_CLASS_FIRMWARE_UPDATE_MD_V2
- * COMMAND_CLASS_SCENE_ACTIVATION
- * COMMAND_CLASS_SCENE_ACTUATOR_CONF

Troubleshooting

Symptom	Cause of Failure	Recommendation
The dimmer does not work and LED off	1.The dimmer does not connect the electrical wire properly 2.The dimmer break down	1. Check power connections 2. Don't open up the dimmer and send it for repair.
The dimmer LED illuminating, but cannot control the ON/OFF state of the load attached	Check if the load connected to the dimmer has its own ON/OFF switch	Set the ON/OFF switch of the load attached to ON
The dimmer LED illuminating, but the Detector cannot control the Switch	1. Not carry out association 2. Same frequency interference	1. Carry out association 2. Wait for a while to re-try

Specification

Input Rating:(Operating Voltage)	100~240Vac / 50Hz~60Hz
Input Rating:(Operating Current)	0.01~1A ; (Maximum: 1A)
Output Rating: Maximum Load (Current)	Maximum: 0.9A (100~240Vac)
Output Rating: Maximum Load (watts) (230V)	200W (13W x 15 pieces) (Dimmable LED bulbs) (230Vac)
Output Rating: Maximum Load (watts) (120V)	100W (13W x 15 pieces) (Dimmable LED bulbs) (120Vac)
Output Rating: Maximum Dimmable LED bulbs	Maximum: 15 pieces (Dimmable LED bulbs)
Operating Temperature	0°C ~ 40°C
Frequency Range	868.40MHz & 869.85MHz/ EU (PAD07-EU); 908.4MHz & 916.0MHz/ USA (PAD07-US);
RF Maximum Power	+5dBm
Transmission Range	Minimum 40 m in door 100m outdoor line of sight
Modulation Type	FSK (Frequency-Shift Keying)

** Specifications are subject to change and improvement without notice.

FCC ID : RHHPAD07



Warning: Do not use Non-Dimmable LED lamps.



DANGER **Danger of electrocution!**

All works on the device may be performed only by a qualified and licensed electrician. Observe national regulations.

Any works introducing changes into the configuration must be always performed with disconnected voltage.

Choosing a Suitable Location

1. Do not locate the Module facing direct sunlight, humid or dusty place.
2. The suitable ambient temperature for the Module is 0°C~40°C.
3. Do not locate the Module where exists combustible substances or any source of heat, e.g. fires, radiators, boiler etc.
4. After putting it into use, the body of Module will become a little bit hot of which phenomenon is normal.

Warning:

1. Plug out to disconnect from power supply; Do not plug in line.
2. Do not exceed the max rating.
3. Do not use Non-Dimmable LED lamps.

Disposal



This marking indicates that this product should not be disposed with other household wastes throughout the EU. To prevent possible harm to the environment or human health from uncontrolled waste disposal, recycle it responsibly to promote the sustainable reuse of material resources. To return your used device, please use the return and collection systems or contact the retailer where the product was purchased. They can take this product for environmental safe recycling.

Company of License Holder : Philio Technology Corporation

Address of License Holder : 8F., No.653-2, Zhongzheng Rd., Xinzhuang Dist., New Taipei City 24257, Taiwan(R.O.C)

FCC Interference Statement

This equipment has been tested and found to comply with the limits for a Class B digital device, pursuant to Part 15 of the FCC Rules.

These limits are designed to provide reasonable protection against harmful interference in a residential installation.

This equipment generates, uses and can radiate radio frequency energy and, if not installed and used in accordance with the instructions, may cause harmful interference to radio communications.

However, there is no guarantee that interference will not occur in a particular installation.

If this equipment does cause harmful interference to radio or television reception, which can be determined by turning the equipment off and on, the user is encouraged to try to correct the interference by one of the following measures:

- Reorient or relocate the receiving antenna.
- Increase the separation between the equipment and receiver.

- Connect the equipment into an outlet on a circuit different from that to which the receiver is connected.
- Consult the dealer or an experienced radio/TV technician for help.

This device complies with Part 15 of the FCC Rules. Operation is subject to the following two conditions:

- (1) This device may not cause harmful interference, and
- (2) This device must accept any interference received, including interference that may cause undesired operation.

FCC Caution: Any changes or modifications not expressly approved by the party responsible for compliance could void the user's authority to operate this equipment.

This transmitter must not be co-located or operating in conjunction with any other antenna or transmitter.