

PAN04-1/-2/-3 In Wall Dual relay(1 way) switch module

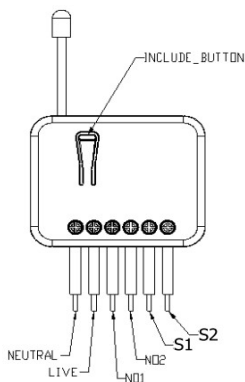

PAN04A1
In Wall Switch (2 RELAY ; 1A TYPE)

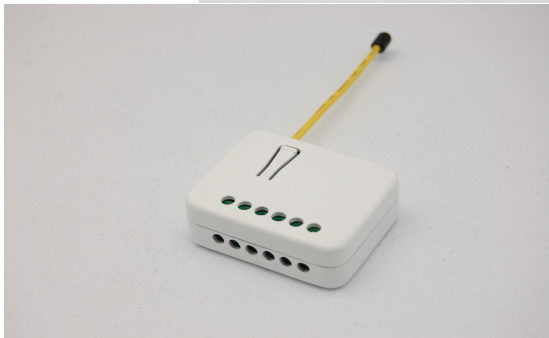
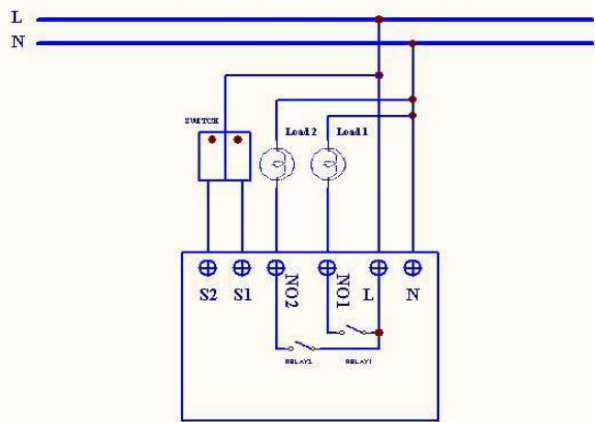

Fig 1. Assembling

This in-wall dual relay switch module is a transceiver which is a Z-Wave™ enabled device and is fully compatible with any Z-Wave™ enabled network. Mini size design let the module can easily hide itself into the wall box and that will be good for the house decoration.

There are many kind of application by using the module to switch AC power On and

Off , one main application is the light control. The new smart relay calibration technology can reduce the inrush current caused by the load and let the module work perfectly with many kind of light like incandescent, fluorescent and LED light.

This in-wall switch module is able to detect Instant power wattage (5~1500W) and overload wattage (1600~1700W) of connected light or appliances. When detecting overload state, the Module will be disabled and its On/Off button will be lockout of which LED will flash quickly. However, disconnect and re-connect the Module will reset its overload condition to normal status.

Adding to Z-Wave™ Network

In the front casing, there is an on/off button with LED indicator below which is used to toggle switch on and off or carry out inclusion, exclusion, reset or association. When first power is applied, its LED flashes on and off alternately and repeatedly at 2-second intervals. It implies that it has not been assigned a node ID and cannot work with Z-Wave enabled devices.

Auto Inclusion

The function of auto inclusion will be executed as long as the in wall switch does not have Node ID and just connect the switch to main power.

Note: Auto inclusion timeout is 4 minute during which the node information of explorer frame will be emitted once every 5 seconds. Unlike “inclusion” function as

shown in the table below, the execution of auto inclusion is free from pressing the On/Off button on the Switch.

The table below lists an operation summary of basic Z-Wave functions. Please refer to the instructions for your Z-Wave™ Certificated Primary Controller to access the Setup function, and to include/exclude/associate devices

Function	Description	LED Indication
No node ID	The Z-Wave Controller does not allocate a node ID to the Switch.	2-second on, 2-second off
Inclusion	1. Have Z-Wave Controller entered inclusion mode.	One press one flash
	2. Pressing INCLUDE_BUTTON three times within 1.5 seconds will enter inclusion mode.	
Exclusion	1. Have Z-Wave Controller entered exclusion mode.	One press one flash
	2. Pressing INCLUDE_BUTTON three times within 1.5 seconds will enter exclusion mode.	
	Node ID has been excluded.	2-second on, 2-second off
Reset	1. Pressing INCLUDE_BUTTON three times within 1.5 seconds will enter inclusion mode.	One press one flash

	2. Within 1 second, press On/Off button again for 5 seconds until LED is off.	
	3. IDs are excluded.	2-second on, 2-second off
Association	1. Have Z-Wave Controller entered association mode. Or Pressing INCLUDE_BUTTON three times within 1.5 seconds will enter association mode	One press one flash
	2. There are 3 groups for the switch	
<p>⊗ Including a node ID allocated by Z-Wave Controller means inclusion. Excluding a node ID allocated by Z-Wave Controller means exclusion.</p> <p>⊗ Failed or success in including/excluding the node ID can be viewed from the Z-Wave Controller.</p>		

LED Indication

To distinguish what mode the switch is in, view from the LED for identification.

State Type	LED Indication
Normal	Whatever we switch On and off of the PAN04 by S1 S2 or On/Off button or RF command , the LED will lights up 1 second and then off.
No node ID	Under normal operation, when the Switch has not been allocated a

	node ID, the LED flashes on and off alternately at 2-second intervals. By pressing S1 S2 or On/Off button, it will stop flashing temporarily. However, after disconnect and reconnect the Switch, the LED will flash on and off alternately at 2-second intervals.
Overload	When overload state occurs, the Switch is disabled of which LED flashes on and off alternately at 0.5 second intervals. Overload state can be cleared by disconnect and reconnect the Switch to the main power

Choosing a Suitable Location

1. Do not locate the Switch facing direct sunlight, humid or dusty place.
2. The suitable ambient temperature for the Switch is 0°C~40°C.
3. Do not locate the Switch where exists combustible substances or any source of heat, e.g. fires, radiators, boiler etc.
4. After putting it into use, the body of Switch will become a little bit hot of which phenomenon is normal.

Installation

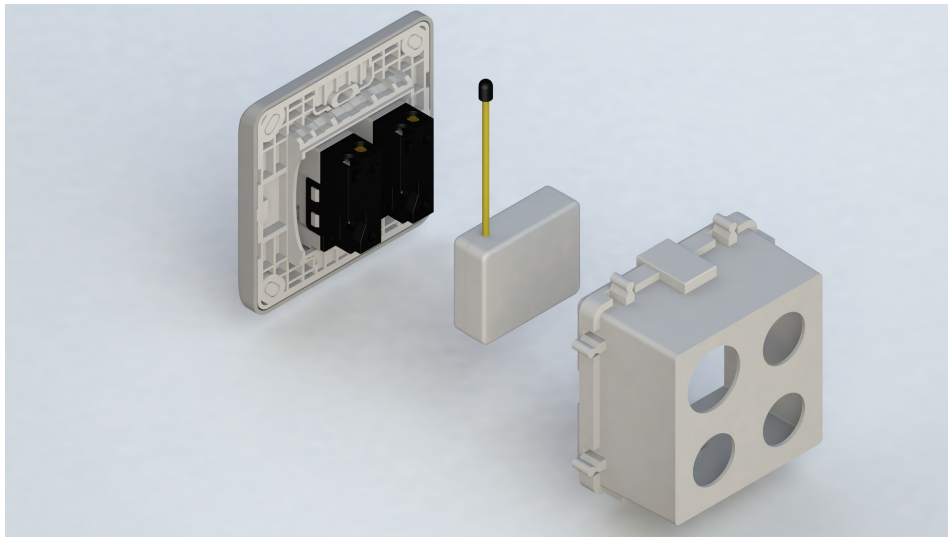

1. put the in wall switch into a wall box and connect the AC power wire L,N to PAN04 connector L, N.
2. Connect the wall switch to the PAN04 as Fig1 .
3. To manually turn ON the Switch, press and release the On/Off button. The LED will light ON for 1 second, and the load plugged into the Switch will also turn ON.
4. To manually turn OFF the Switch, simply press and release the On/Off button. The LED will light ON for 1 second and the load plugged into the Switch will turn

OFF.

Programming

1. Basic Command Class / Binary Switch Command Class

The Switch will respond to BASIC and BINARY commands that are part of the Z-Wave system.

1-1 BASIC_GET / BINARY_SWITCH_GET

Since the switch have two relay, the Switch will report its On/Off state to the Controller by setting Configuration parameter 3.

Configuration parameter 3=1(default) Report ON either relay 1 ON or relay 2 ON

Report OFF when both relay 1 and relay 2 OFF

Configuration parameter 3=2 Report ON when relay 1 ON

Report OFF when relay 1 OFF

Configuration parameter 3=3 Report ON when relay 2 ON

Report OFF when relay 2 OFF

Basic Get Command: **[Command Class Basic, Basic Get]**

Basic Report Command:

Report OFF: **[Command Class Basic, Basic Report, Value = 0(0x00)]**

Report ON: **[Command Class Basic, Basic Report, Value = (255)0xFF]**

Binary Switch Get Command: **[Command Class Switch Binary, Switch Binary Get]**

Binary Switch Report Command:

Report OFF: **[Command Class Switch Binary, Switch Binary Report, Value = 0(0x00)]**

Report ON: **[Command Class Switch Binary, Switch Binary Report, Value = (255)0xFF]**

1-2 BASIC_SET / SWITCH_BINARY_SET

Since the switch have two relay, the load attached to the Switch will turn on or off upon receipt of the following commands from a Z-Wave Controller by setting Configuration parameter 3.

Configuration parameter 3=1(default) switch ON and OFF both relay 1 and relay 2

Configuration parameter 3=2 switch ON and OFF of relay 1

Configuration parameter 3=3 switch ON and OFF of relay 2

[Command Class Basic, Basic Set, Value = (255)0xFF]: the load attached to

the Switch turns on.

[Command Class Basic, Basic Set, Value = 0(0x00)]: the load attached to the Switch turns off.

[Command Class Switch Binary, Switch Binary Set, Value = (255)0xFF]: the load attached to the Switch turns on.

[Command Class Switch Binary, Switch Binary Set, Value = 0(0x00)]: the load attached to the Switch turns off.

2. Z-Wave's Groups (Association Command Class Version 1)

The Switch can be set to send reports to control associated Z-Wave devices. It supports 3 association groups which every group has one node support. Group1~Group3 support SWITCH_BINARY_REPORT, METER_REPORT_COMMAND_V3

For group 1, the Switch will report (1) ON/OFF status of Relay1 and Relay2 (2) Instant Power Consumption (Watt) of Relay1 and Relay2 (3) Accumulated Power Consumption (KWh) of Relay1 and Relay2 to Z-Wave Controller.

For group 2, the Switch will report (1) ON/OFF status of Relay1 (2) Instant Power Consumption (Watt) of Relay1 (3) Accumulated Power Consumption (KWh) of Relay1 to Z-Wave Controller.

For group 3, the Switch will report (1) ON/OFF status of Relay2 (2) Instant Power Consumption (Watt) of Relay2 (3) Accumulated Power Consumption (KWh) of Relay2

to Z-Wave Controller.

2-1 Auto report to Grouping 1 ~3(Maximum Node 1)

2-1-1 On/Off Event Report

When "on" or "off" state has been changed by pressing S1 S2 or on/off button, it will send Binary Switch Report to the nodes of Group1~3. But if "on" or "off" state has been changed by RF command (ex. Switch Binary set · All Switch ON/OFF or Basic Set), it will not send.

Binary Switch Report

ON:**[Command Class Switch Binary, Switch Binary Report, Value = (255)0xFF]**

OFF:**[Command Class Switch Binary, Switch Binary Report, Value = 0(0x00)]**

2-1-2 Instant Power Consumption vary over 5% report

When the power consumption of load vary over 5%, it will send Meter report to the nodes of Group

Meter Report Command: **[Command Class Meter · Meter Report · scale(bit 2) +Rate Type +Meter Type · Precision + Scale(bit 1,0)+ Size · Meter Value 1 · Meter Value 2 · Meter Value 3 · Meter Value 41]**

2-1-3 overload alarm report command

When PAN04 detect the overload , it will send Alarm Report to the correspond Group °

The content of Alarm Report

Alarm report command: [Command_Class_Alarm, Alarm_Report, Alarm Type = 0x08, Alarm Level = 0xFF]

2-2 Response to Meter Get Command

The Switch will report its (1) instant Power Consumption (Watt) or (2) accumulated power consumption(KWH) or (3) AC load Voltage (V) or (4) AC load current (I) (5) load power factor (PF) to Z-Wave Controller after receive the Meter Get Command from Z-Wave Controller.

2-2-1 Instant Power Consumption (Watt) of Switch

When receiving Meter Get Command, it will report Meter Report Command to the node asked.

Meter Get Command: [Command Class Meter, Meter Get, Scale =0x02(W)]

Meter Report Command: [Command Class Meter , Meter Report , scale(bit 2) +Rate Type +Meter Type , Precision + Scale(bit 1,0)+ Size , Meter Value 1 , Meter Value 2 , Meter Value 3 , Meter Value 4]

Rate Type = 0x01

Meter Type = 0x01

Precision = 1

Scale = 0x02(W)

Size = 4 Bytes (Meter Value)

Meter Value 1 = (W) MSB

Meter Value 2 = (W)

Meter Value 3 = (W)

Meter Value 4 = (W)LSB

Example:

Meter Value 1 = 0x00 (W)

Meter Value 2 = 0x00 (W)

Meter Value 3 = 0x03 (W)

Meter Value 4 = 0xEA (W)

Meter(W) = Meter Value 3 *256 + Meter Value 4 = 100.2W

2-2-2 Accumulated Power Consumption (KW/h)

When receiving Meter Get Command, it will report Meter Report Command to

the node asked.

Meter Get Command: **[Command Class Meter, Meter Get, Scale = 0x00 KW/h]**

Meter Report Command: **[Command Class Meter , Meter Report , scale(bit 2) +Rate Type +Meter Type , Precision + Scale(bit 1,0)+ Size , Meter Value 1 , Meter Value 2 , Meter Value 3 , Meter Value 4]**

Rate Type = 0x01

Meter Type = 0x01

Precision = 2

Scale = 0x00 (KWh)

Size = 4 bytes (Meter Value)

Meter Value 1 = (W) MSB

Meter Value 2 = (W)

Meter Value 3 = (W)

Meter Value 4 = (W) LSB

Example:

Scale = 0x00 (KWh)

Precision = 2

Size = 4 Bytes (KW/h)

Meter Value 1 = 0x00(W)

Meter Value 2 = 0x01(W)

Meter Value 3 = 0x38(W)

Meter Value 4 = 0xA3(W)

Accumulated power consumption (KW/h) = (Meter Value 2*65536) + (Meter Value 3*256) + (Meter Value 4) = 800.35 (KW/h)

2-2-3 Clearing accumulated power consumption

Meter Reset Command: **[Command Class Meter, Meter Reset]**

2-2-4 AC load Voltage (V)

When receiving Meter Get Command, it will report Meter Report Command to the node asked.

Meter Get Command: **[Command Class Meter, Meter Get, Scale =0x04(V)]**

Meter Report Command:
[Command Class Meter , Meter Report , scale(bit 2) +Rate Type +Meter Type , Precision + Scale(bit 1,0)+ Size , Meter Value 1 , Meter Value 2]

Rate Type = 0x01

Meter Type = 0x01

Precision = 1

Scale = 0x04(V)

Size = 2 Bytes (Meter Value)

Meter Value 1 = High Byte (V)

Meter Value 2 = Low Byte (V)

Example:

Scale = 0x04 (V)

Precision = 1

Size = 2 (2 Bytes of V)

Meter Value 1 = 0x09(V)

Meter Value 2 = 0x01(V)

AC load Voltage = (Meter Value 1*256) +(Meter Value 2)= 230.5 (V)

2-2-5 AC load current (I)

When receiving Meter Get Command, it will report Meter Report Command to the node asked.

Meter Get Command: **[Command Class Meter, Meter Get, Scale =0x05(I)]**

Meter Report Command:
[Command Class Meter , Meter Report , scale(bit 2) +Rate Type +Meter Type , Precision + Scale(bit 1,0)+ Size , Meter Value 1 , Meter Value 2]

Rate Type = 0x01

Meter Type = 0x01

Precision = 2

Scale = 0x05(I)

Size = 2 Bytes (Meter Value)

Meter Value 1 = High Byte (I)

Meter Value 2 = Low Byte (I)

Example:

Scale = 0x05 (I)

Precision = 2

Size = 2 (2 Bytes of I)

Meter Value 1 = 0x01(I)

Meter Value 2 = 0x21(I)

AC load current = (Meter Value 1*256) +(Meter Value 2)= 2.89 (A)

2-2-6 load power factor (PF)

When receiving Meter Get Command, it will report Meter Report Command to the node asked.

Meter Get Command: **[Command Class Meter, Meter Get, Scale =0x06(PF)]**

Meter Report Command:
[Command Class Meter , Meter Report , scale(bit 2) +Rate Type +Meter Type , Precision + Scale(bit 1,0)+ Size , Meter Value 1]

when both Relay 1 and Relay2 OFF . If endpoint set to 2 , PAN04 will reply state of Relay1 . If endpoint set to 3 and PAN04 will reply state of Relay2

Below is a example show a source endpoint 5 send a get command to PAN04 endpoint 1

Rate Type = 0x01
 Meter Type = 0x01
 Precision = 2
 Scale = 0x06(PF)
 Size = 1 Bytes
 Meter Value 1

Example:

Scale = 0x06 (PF)
 Precision = 2
 Size = 1 (1 Byte of PF)
 Meter Value 1 = 0x63(PF)
 Load power factor (PF) = Meter Value 1 =0.99

2-3 Multi Channel Command Class Version 3

PAN04 also support muti channel command class(version 3) , which include BINARY_SWITCH_GET, BINARY_SWITCH_SET, METER_SUPPORTED_GET, METER_RESET,METER_GET

You may control or get report from 3 endpoint of PAN04

2-3-1 BINARY_SWITCH_GET,

You may get the ON/OFF state from every endpoint, when endpoint set to 1 , PAN04 will reply ON(0xFF) either Relay 1 or Relay2 is ON, report OFF (0x00)

COMMAND_CLASS_MULTI_CHANNEL	
MULTI_CHANNEL_CMD_ENCAP	
Source End Point = 0x05	(this is the endpoint of command owner here we assume endpoint is 5 , if the owner doesn't support multi Channel this value will be 0)
(Bit Address+Destination End Point = 0x01)	(Bit Address =0 ; Destination End Point range from 1~3)
Command Class = 0x25	(Command_Class_Switch_Binary = 0x25)
Command =0x02	(Switch_Binary_Get = 0x02)

Below is the example show PAN04 report to last command

COMMAND_CLASS_MULTI_CHANNEL	
MULTI_CHANNEL_CMD_ENCAP	
Source End Point = 0x01	Since the endpoint is 1 so PAN04 will

	reply ON(0xFF) either Relay 1 or Relay2 is ON, report OFF (0x00) when both Relay 1 and Relay2 OFF
(Bit Address+Destination End Point = 0x05)	(Bit Address =0 ; Destination End Point)
Command Class = 0x25	(Command_Class_Switch_Binary = 0x25)
Command =0x03	(Switch_Binary_Reportet = 0x3)
Parameter 1 = 0xFF	(ON=0xFF , OFF=0x00)

2-3-2 BINARY_SWITCH_SET

By using BINARY_SWITCH_SET Command of Multi Channel Command Class Encapsulateion Command, you can switch both Relay1 and Relay2 ON/OFF by setting endpoint to 1 or switch Relay1 ON/OFF by setting endpoint to 2 or switch Relay1 ON/OFF by setting endpoint to 3

The example of the command show that switch off relay1 of PAN04

COMMAND_CLASS_MULTI_CHANNEL	(this is the endpoint of command owner here we assume endpoint is 1 , if the owner doesn't support multi Channel
MULTI_CHANNEL_CMD_ENCAP	
Source End Point = 0x01	

	this value will be 0)
(Bit Address+Destination End Point = 0x02)	(Bit Address =0 ; Destination End Point range1~3)
Command Class = 0x25	(Command_Class_Switch_Binary = 0x25)
Command =0x01	(Switch_Binary_Set = 0x01)
Parameter 1 = 0x00	(ON=0xFF , OFF=0x00)

2-3-3 METER_SUPPORTED_GET :

This command is to ask the endpoint of PAN04 what kind of meter data can be reported

The example show how to get the meter report type

COMMAND_CLASS_MULTI_CHANNEL	(this is the endpoint of command owner here we assume endpoint is 1 , if the owner doesn't support multi Channel this value will be 0)
MULTI_CHANNEL_CMD_ENCAP	
Source End Point = 0x01	
(Bit Address+Destination End Point = 0x03)	(Bit Address =0 ; Destination End Point

	range1~3)
Command Class = 0x32	(Command_Class_Meter_V3 = 0x32)
Command =0x03	(Meter_Supported_Get = 0x03)

Below is the example show PAN04 report to last command

COMMAND_CLASS_MULTI_CHANNEL	
MULTI_CHANNEL_CMD_ENCAP	
Source End Point = 0x03	
(Bit Address+Destination End Point = 0x01)	
Command Class = 0x32	(Command_Class_Meter_V3 = 0x32)
Command =0x04	(Meter_Supported_Report = 0x04)
Parameter 1 = 0x81	(Meter Reset =1 , Meter Type=0x01)
Parameter 2 = 0x75	(Scale Supported = KWh+W+V+A+Power Factor = 0x75)

2-3-4 METER_RESET

This command is to reset the Accumulated Power Consumption (KWh) to 0

The example show how to reset the KWh

COMMAND_CLASS_MULTI_CHANNEL	
MULTI_CHANNEL_CMD_ENCAP	

Source End Point = 0x03	(this is the endpoint of command owner, here we assume endpoint is 3 · if the owner doesn't support multi Channel this value will be 0)
(Bit Address+Destination End Point = 0x01)	(Bit Address =0 ; Destination End Point range1~3)
Command Class = 0x32	(Command_Class_Meter_V3 = 0x32)
Command =0x05	(Meter_Reset = 0x05)

2-3-5 METER_GET :

Using meter get command to get the KWH,W,V,I,PF from endpoint of PAN04

2-3-5-1 Get KWH from endpoint

Meter_GET example:

COMMAND_CLASS_MULTI_CHANNEL	
MULTI_CHANNEL_CMD_ENCAP	
Source End Point = 0x05	(this is the endpoint of command owner, here we assume endpoint is 5 · if the owner doesn't support multi Channel this value will be 0)
(Bit Address+Destination End Point = 0x03)	(Bit Address =0 ; Destination End Point range1~3)
Command Class = 0x32	(Command_Class_Meter_V3 = 0x32)

Command =0x01	(Meter_Get = 0x01)
Parameter 1 = 0x00	(Scale = KWH = 0x00)

Accumulated power consumption (KWH) Report example :

COMMAND_CLASS_MULTI_CHANNEL	
MULTI_CHANNEL_CMD_ENCAP	
Source End Point = 0x03	(Meter report = Endpoint3)
(Bit Address+Destination End Point = 0x05)	(Bit Address =0 ; Destination End Point = command owner Endpoint value)
Command Class = 0x32	(Command_Class_Meter_V3 = 0x32)
Command =0x02	(Meter_Report = 0x02)
Parameter 1 = 0x21	(Scale Bit2 = 0 , Rate Type = 0x01 , Meter Type=0x01)
Parameter 2 = 0x44	(Precision = 2 , Scale Bit1Bit0 = 0 , Size = 4)
Parameter 3 = 0x00	Accumulated Power Consumption =
Parameter 4 = 0x00	0x000005FD = 15.33 KWh
Parameter 5 = 0x05	

Parameter 6 = 0xFD	
--------------------	--

2-3-5-2 Get Instant Power Consumption (Watt) from endpoint

METER_GET example :

COMMAND_CLASS_MULTI_CHANNEL	
MULTI_CHANNEL_CMD_ENCAP	
Source End Point = 0x05	(this is the endpoint of command owner, here we assume endpoint is 5 , if the owner doesn't support multi Channel this value will be 0)
(Bit Address+Destination End Point = 0x03)	(Bit Address =0 ; Destination End Point range 1~3)
Command Class = 0x32	(Command_Class_Meter_V3 = 0x32)
Command =0x01	(Meter_Get = 0x01)
Parameter 1 = 0x10	(Scale = W = 0x02)

PAN04 Instant Power Consumption (W) Report example :

COMMAND_CLASS_MULTI_CHANNEL	
MULTI_CHANNEL_CMD_ENCAP	
Source End Point = 0x03	(Meter report = Endpoint3)

(Bit Address+Destination End Point = 0x05)	(Bit Address =0 ; Destination End Point = command owner Endpoint value)
Command Class = 0x32	(Command_Class_Meter_V3 = 0x32)
Command =0x02	(Meter_Report = 0x02)
Parameter 1 = 0x21	(Scale Bit2 = 0 , Rate Type = 0x01 , Meter Type=0x01)
Parameter 2 = 0x34	(Precision = 1 , Scale Bit1Bit0 = 0x02 , Size = 4)
Parameter 3 = 0x00	Instant Power Consumption =
Parameter 4 = 0x00	0x000003EA
Parameter 5 = 0x03	= 100.2W
Parameter 6 = 0xEA	

2-3-5-3 Get load voltage V from endpoint

Meter_GET example:

COMMAND_CLASS_MULTI_CHANNEL	(this is the endpoint of command owner, here we assume endpoint is 5 , if the owner doesn't support multi Channel this
MULTI_CHANNEL_CMD_ENCAP	
Source End Point = 0x05	

	value will be 0)
(Bit Address+Destination End Point = 0x03)	(Bit Address =0 ; Destination End Point range1~3)
Command Class = 0x32	(Command_Class_Meter_V3 = 0x32)
Command =0x01	(Meter_Get = 0x01)
Parameter 1 = 0x20	(Scale = V = 0x04)

PAN04 AC load Voltage report example :

COMMAND_CLASS_MULTI_CHANNEL	
MULTI_CHANNEL_CMD_ENCAP	
Source End Point = 0x03	
(Bit Address+Destination End Point = 0x05)	(Bit Address =0 ; Destination End Point = command owner Endpoint value)
Command Class = 0x32	(Command_Class_Meter_V3 = 0x32)
Command =0x02	(Meter_Report = 0x02)
Parameter 1 = 0xA1	(Scale Bit2 = 1 , Rate Type = 0x01 , Meter Type=0x01)
Parameter 2 = 0x22	(Precision = 1 , Scale Bit1Bit0 = 0x00 , Size = 2)

Parameter 3 = 0x09	Voltage = 0x0910 = 232.0V
Parameter 4 = 0x10	

2-3-5-4 Get load current I from endpoint

Meter_GET example:

COMMAND_CLASS_MULTI_CHANNEL	(this is the endpoint of command owner, here we assume endpoint is 5 , if the owner doesn't support multi Channel this value will be 0)	
MULTI_CHANNEL_CMD_ENCAP		
Source End Point = 0x05		
(Bit Address+Destination End Point = 0x03)		(Bit Address =0 ; Destination End Point range1~3)
Command Class = 0x32		(Command_Class_Meter_V3 = 0x32)
Command =0x01		(Meter_Get = 0x01)
Parameter 1 = 0x28		(Scale = A = 0x05)

PAN04 AC load current (I) example :

COMMAND_CLASS_MULTI_CHANNEL

MULTI_CHANNEL_CMD_ENCAP	(this is the endpoint of command owner, here we assume endpoint is 5 , if the owner doesn't support multi Channel this value will be 0)	
Source End Point = 0x03		(Meter report = Endpoint3)
(Bit Address+Destination End Point = 0x05)		(Bit Address =0 ; Destination End Point = command owner Endpoint value)
Command Class = 0x32		(Command_Class_Meter_V3 = 0x32)
Command =0x02		(Meter_Report = 0x02)
Parameter 1 = 0xA1		(Scale Bit2 = 1 , Rate Type = 0x01 , Meter Type=0x01)
Parameter 2 = 0x4A		(Precision = 2 , Scale Bit1Bit0 = 0x01 , Size = 2)
Parameter 3 = 0x00	Current = 0x002B = 0.43A	
Parameter 4 = 0x2B		

2-3-5-5 Get power factor PF from endpoint

Meter_GET example:

COMMAND_CLASS_MULTI_CHANNEL	(this is the endpoint of command owner, here we assume endpoint is 5 , if the owner doesn't support multi Channel this value will be 0)
MULTI_CHANNEL_CMD_ENCAP	
Source End Point = 0x05	

(Bit Address+Destination End Point = 0x03)	(Bit Address =0 ; Destination End Point range1~3)
Command Class = 0x32	(Command_Class_Meter_V3 = 0x32)
Command =0x01	(Meter_Get = 0x01)
Parameter 1 = 0x30	(Scale = PF = 0x06)

Parameter 3 = 0x63	Power Factor = 0x63 = 0.99
--------------------	----------------------------

3. Z-Wave's Configuration

PAN04 power factor report example :

COMMAND_CLASS_MULTI_CHANNEL	
MULTI_CHANNEL_CMD_ENCAP	
Source End Point = 0x03	(Meter report = Endpoint3)
(Bit Address+Destination End Point = 0x05)	(Bit Address =0 ; Destination End Point = command owner Endpoint value)
Command Class = 0x32	(Command_Class_Meter_V3 = 0x32)
Command =0x02	(Meter_Report = 0x02)
Parameter 1 = 0xA1	(Scale Bit2 = 1 , Rate Type = 0x01 , Meter Type=0x01)
Parameter 2 = 0x51	(Precision = 2 , Scale Bit1Bit0 = 0x10 , Size = 1)

Configuration Parameter	Function	Size (Byte)	Value	Unit	Default	Description
1	Watt Meter Report Period	2	0x01-0x7FFF	5s	720	5*720s=3600s=1 hour
2	KWH Meter Report Period	2	0x01-0x7FFF	10min	6	6*10min= 1 hour
3	Slected End Point	1	1-3		1	1 : Relay1 & Relay2 2 : Relay1 3 : Relay2
4	Edge or Pulse mode or Edge-Toggle	1	1-3		1	1 : Edge mode 2 : Pulse mode 3 : Edge-Toggle mode

	mode					
5	Threshold of Watt for Load Caution	2	10-1500	1watt	1500	
6	Threshold of KWH for Load Caution	2	1-10000	1KWh	10000	

3-1 Watt Meter Report Period:

If the setting is configured for 1hour (set value =720), the PAN04 will report its instant power consumption every 1 hour to the node of correspond Group. The maximum interval to report its instant power consumption is 45 hours ($5s*32767/3600=45hr$).

3-2 KWH Meter Report Period:

If the setting is configured for 1hour (set value =6), the PAN04 will report its Accumulated Power Consumption (KW/h) every 1 hour to the node of correspond Group. The maximum interval to report its Accumulated Power Consumption (KW/h) is 227.55 days ($10min*32767/1440=227.55$ days).

3-3 Selected Endpoint

If Controller not using Multi_Channel command class to access the endpoint of PAN04, you may configure the endpoint value to react the Basic Command Class
 · Binary Switch Command Class or Meter Command Class V3

3-3-1 Selected Endpoint 1 : Default Selected Endpoint is 1

Set command	Relay state	
Basic Set or Binary_Switch_Set ON	Relay1 ON & Relay2 ON	
Basic Set or Binary_Switch_Set OFF	Relay1 OFF & Relay2 OFF	

Get command	Relay state	Report to command sender
Basic_Get or Binary_Switch_Get	Relay1 ON or Relay2 ON	ON
Basic_Get or Binary_Switch_Get	Relay1 OFF & Relay2 OFF	OFF

Get command	parameter	Report to command sender
Meter_Get	KWh	Relay1 KWh1+Relay2 KWh2
Meter_Get	Watt	Relay1 W1+Relay2 W2
Meter_Get	Voltage	Relay1 and Relay2 same voltage

Meter_Get	Current	Relay1 I1+Relay2 I2
Meter_Get	Power factor PF	Relay1

3-3-2 Selected Endpoint 2

Similar like Selected Endpoint 1 but only relate to Relay1 and ignore Relay2

3-3-3 Selected Endpoint 3

Similar like Selected Endpoint 1 but only relate to Relay2 and ignore Relay1

3-4 Edge and Pulse mode

Manual switch S1 and S2 can set to Edge mode or Pulse mode or Edge-Toggle mode , default value is Edge mode.

Edge mode: this mode is suitable for the bi stable wall switch that has indicator point on the switch, and the same position correspond to same state of relay1 and relay2 . if the PAN04 relay change the state because of receiving Z-Wave RF command, it may need two times of change (switch on to off or switch off to on) to let relay back to the correspond state.

Pulse mode: this mode is suitable for the toggle type wall switch to swap the state of Relay1 or Relay2

Edge-Toggle mode: this mode is suitable for the normal bi-stable switch, every time when change the state of the wall switch will also swap the state of Relay1 or Relay2

3-5 Threshold of Watt for Load Caution

This is a warning when the wattage of load over the preset threshold value, If the setting value is 1500, when the load wattage of Relay1 or Relay2 over this value, PAN04 will send Watt Meter Report command to the node of correspond Group.

3-6 Threshold of KWh for Load Caution

This is a warning when the KWh of load over the preset threshold value, If the setting value is 10000, when the Accumulated Power Consumption of Relay1 or Relay2 over this value, PAN04 will send KWh Meter Report command to the node of correspond Group, minum value is 1KWh and default value is 10000 kWh

4. Command Classes

The Switch supports Command Classes including...

- * COMMAND_CLASS_SWITCH_BINARY
- * COMMAND_CLASS_BASIC
- * COMMAND_CLASS_MANUFACTURER_SPECIFIC_V2
- * COMMAND_CLASS_VERSION
- * COMMAND_CLASS_SWITCH_ALL
- * COMMAND_CLASS_ASSOCIATION_V1
- * COMMAND_CLASS_METER_V3
- * COMMAND_CLASS_CONFIGURATION
- * COMMAND_CLASS_MULTI_CHANNEL_V3
- * COMMAND_CLASS_ALARM

Note: Please make sure that the intensity of the plug of the electrical device must be 16A and have same head as the enclosed plug before inserting to the socket.

Troubleshooting

Symptom	Cause of Failure	Recommendation
The Switch not working and LED off	1. The Switch is not connect to the Main power 2. The Switch break down	1. Check power connections 2. Don't open up the Switch and send it for repair.
The Switch LED illuminating, but cannot control the ON/OFF Switch of the load attached	Check if the load connect into the Switch has its own ON/OFF switch	Set the ON/OFF switch of the load attached to ON
The Switch LED illuminating, but the Detector cannot control the Switch	1. Not carry out association 2. Same frequency interference	1. Carry out association 2. Wait for a while to re-try
LED keep flashing 30 seconds, but cannot control	Overload occurs	Remove the load attached or check max. load cannot exceed 1500W~1650W

Specification

Operating Voltage	100 ~240VAC 24-60V DC $\pm 10\%$ (working in this voltage range will have no meter function)
-------------------	---

Maximum Load	1500W X2 (220V) 800W X 2 (120V)
Range	Minimum 30 m in door 100m outdoor line of sight
Operating Temperature	0°C ~ 40°C
Frequency Range	PAN04-1 868.42 (EU) / PAN04-2 908.42(USA/Canada) / PAN04-3 922.5/923.9/926.3MHz (Taiwan/Jp)MHz

** Specifications are subject to change and improvement without notice.



Warning:

1. Plug out to disconnect from power supply; Do not plug in line.
2. Do not exceed the max rating

Disposal

	<p>This marking indicates that this product should not be disposed with other household wastes throughout the EU. To prevent possible harm to the environment or human health from uncontrolled waste disposal, recycle it responsibly to promote the sustainable reuse of material resources. To return your used device, please use the return and collection systems or contact the retailer where the product was purchased. They can take this product for environmental safe recycling.</p>
--	---

Company of License Holder : Philio Technology Corporation

Address of License Holder : 8F.,No.653-2,Zhongzheng Rd., Xinzhuang Dist., New

FCC Interference Statement

This equipment has been tested and found to comply with the limits for a Class B digital device, pursuant to Part 15 of the FCC Rules.

These limits are designed to provide reasonable protection against harmful interference in a residential installation.

This equipment generates, uses and can radiate radio frequency energy and, if not installed and used in accordance with the instructions, may cause harmful interference to radio communications.

However, there is no guarantee that interference will not occur in a particular installation.

If this equipment does cause harmful interference to radio or television reception, which can be determined by turning the equipment off and on, the user is encouraged to try to correct the interference by one of the following measures:

- Reorient or relocate the receiving antenna.
- Increase the separation between the equipment and receiver.
- Connect the equipment into an outlet on a circuit different from that to which the receiver is connected.
- Consult the dealer or an experienced radio/TV technician for help.

This device complies with Part 15 of the FCC Rules. Operation is subject to the following two conditions:

- (1) This device may not cause harmful interference, and
- (2) This device must accept any interference received, including interference that may cause undesired operation.

FCC Caution: Any changes or modifications not expressly approved by the party responsible for compliance could void the user's authority to operate this equipment.