

## PAN06-1/-2/-3 In Wall Dual relay(1 way) switch module

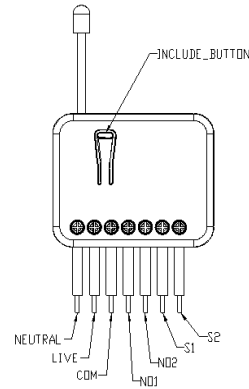

technology can reduce the inrush current caused by the load and let the module work perfectly with many kind of light like incandescent, fluorescent and LED light. This module can also connect to alternative power supply like DC 12V to switch on/off 12V MR-16 light as follow picture.

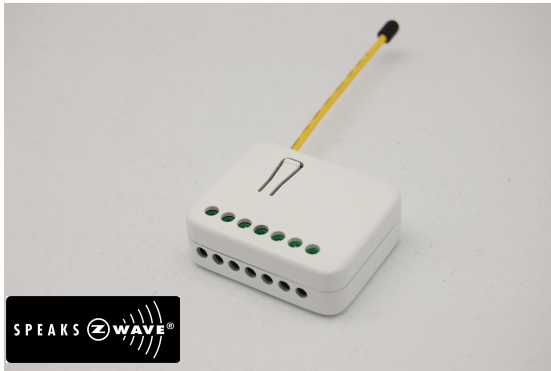

### Adding to Z-Wave™ Network

In the front casing, there is an on/off button with LED indicator below which is used to toggle switch on and off or carries out inclusion, exclusion, reset or association. When first power is applied, its LED flashes on and off alternately and repeatedly at 2-second intervals. It implies that it has not been assigned a node ID and cannot work with Z-Wave enabled devices.

### Auto Inclusion

The function of auto inclusion will be executed as long as the in wall switch does not have Node ID and just connect the switch to main power.

**Note:** Auto inclusion timeout is 4 minute during which the node information of explorer frame will be emitted once every 5 seconds. Unlike “inclusion” function as shown in the table below, the execution of auto inclusion is free from pressing the On/Off button on the Switch.

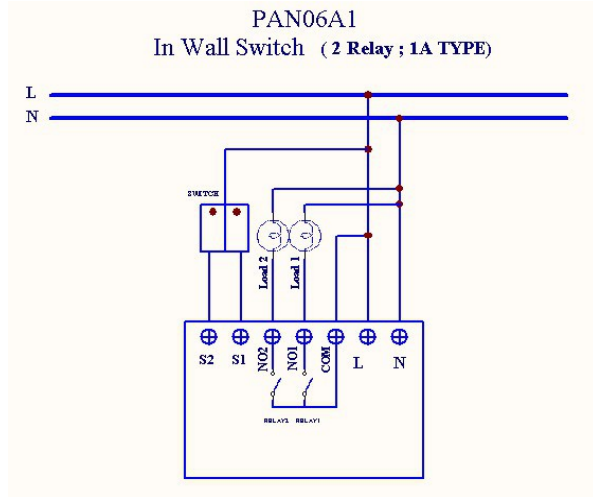

**Fig 1. Assembling**

This in-wall switch module is a transceiver which is a Z-Wave™ enabled device and is fully compatible with any Z-Wave™ enabled network. Mini size design let the module can easily hide itself into the wall box and that will be good for the house decoration.

There are many kind of application by using the module to switch Load On and Off , one main application is the light control. If connect the com port directly to AC Line terminal ,the new smart relay calibration

The table below lists an operation summary of basic Z-Wave functions. Please refer to the instructions for your Z-Wave™ Certificated Primary Controller to access the Setup function, and to include/exclude/associate devices

Function	Description	LED Indication
No node ID	The Z-Wave Controller does not allocate a node ID to the Switch.	2-second on, 2-second off
Inclusion	1. Have Z-Wave Controller entered inclusion mode.	One press one flash
	2. Pressing Include button of PAN06 three times within 1.5 seconds will enter inclusion mode.	
Exclusion	1. Have Z-Wave Controller entered exclusion mode.	One press one flash
	2. Pressing Include button of PAN06 three times within 1.5 seconds will enter exclusion mode.	
	Node ID has been excluded.	2-second on, 2-second off
Reset	1. Pressing Include button of PAN06 three times within 1.5 seconds will enter inclusion mode.	One press one flash
	2. Within 1 second, press Include button of PAN06 again for 5 seconds until LED is off.	
	3. IDs are excluded.	2-second on, 2-second off

Association	1. Have Z-Wave Controller entered association mode. Or Pressing Include button of PAN06 three times within 1.5 seconds will enter association mode	One press one flash
	2. There are 3 groups for the switch	
※Including a node ID allocated by Z-Wave Controller means inclusion. Excluding a node ID allocated by Z-Wave Controller means exclusion. ※Failed or success in including/excluding the node ID can be viewed from the Z-Wave Controller.		

Sometimes people are not easy to execute exclusion or inclusion especially when PAN06 already installed in a wall box. To solve this issue, PAN06 support a special feature that can use S1 or S2 to execute “exclusion, inclusion, Reset or Association” at the first 3 minutes when first time connect to main power.

### LED Indication

To distinguish what mode the switch is in, view from the LED for identification.

State Type	LED Indication
Normal	Whenever we switch On and off of the PAN06 by S1 S2 or On/Off button or RF command , the LED will lights up 1 second and then off.
No node ID	Under normal operation, when the Switch has not been allocated a node ID, the LED flashes on and off alternately at 2-second intervals. By pressing S1 S2 or On/Off button, it will stop flashing

	temporarily. However, after disconnect and reconnect the Switch, the LED will flash on and off alternately at 2-second intervals.

## Choosing a Suitable Location

1. Do not locate the Switch facing direct sunlight, humid or dusty place.
2. The suitable ambient temperature for the Switch is 0°C~40°C.
3. Do not locate the Switch where exists combustible substances or any source of heat, e.g. fires, radiators, boiler etc.
4. After putting it into use, the body of Switch will become a little bit hot of which phenomenon is normal.

## Installation

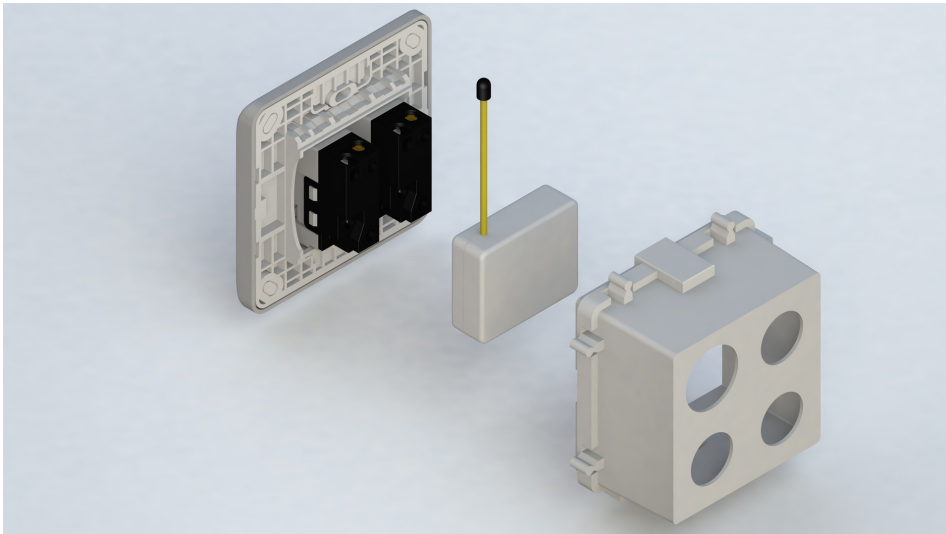

1. Put the in wall switch into a wall box and connect the AC power wire L,N to PAN06 connector L, N.
2. Connect the wall switch to the PAN06 as Fig1 .
3. There are 3 mode PAN06 can be configured to match different kind of wall switch, please refer to **3-2 Edge / Pulse / Edge-Toggle mode** which described in next section of this user manual
4. If Edge-Toggle mode has been set, and the S1 S2 is connect to normal bi-stable switch, every time when change the state of the wall switch will also swap the state of Relay1 or Relay2

## Programming

### 1. Basic Command Class / Binary Switch Command Class

The Switch will respond to BASIC and BINARY commands that are part of the Z-Wave system.

#### 1-1 BASIC\_GET / BINARY\_SWITCH\_GET

Since the switch have two relay, the Switch will report its On/Off state to the Controller by setting Configuration parameter 1.

Configuration parameter 1=1(default) Report ON either relay 1 ON or relay 2 ON

Report OFF when both relay 1 and relay 2 OFF

Configuration parameter 1=2 Report ON when relay 1 ON

Report OFF when relay 1 OFF

Configuration parameter 1=3 Report ON when relay 2 ON

Report OFF when relay 2 OFF

Configuration parameter 1=2 switch ON and OFF of relay 1

Configuration parameter 1=3 switch ON and OFF of relay 2

Basic Get Command: **[Command Class Basic, Basic Get]**

Basic Report Command:

Report OFF: **[Command Class Basic, Basic Report, Value = 0(0x00)]**

Report ON:**[Command Class Basic, Basic Report, Value = (255)0xFF]**

Binary Switch Get Command:**[Command Class Switch Binary, Switch Binary Get]**

Binary Switch Report Command:

Report OFF:**[Command Class Switch Binary, Switch Binary Report, Value =0(0x00)]**

Report ON:**[Command Class Switch Binary, Switch Binary Report, Value = (255)0xFF]**

**[Command Class Basic, Basic Set, Value = (255)0xFF]:** the load attached to the Switch turns on.

**[Command Class Basic, Basic Set, Value = 0(0x00)]:** the load attached to the Switch turns off.

**[Command Class Switch Binary, Switch Binary Set, Value = (255)0xFF]:** the load attached to the Switch turns on.

**[Command Class Switch Binary, Switch Binary Set, Value = 0(0x00)]:** the load attached to the Switch turns off.

### 1-2 BASIC\_SET / SWITCH\_BINARY\_SET

Since the switch have two relay, the load attached to the Switch will turn on or off upon receipt of the following commands from a Z-Wave Controller by setting Configuration parameter 1.

Configuration parameter 1=1(default) switch ON and OFF both relay 1 and relay 2

### 2. Z-Wave's Groups (Association Command Class Version 1)

The Switch can be set to send reports to control associated Z-Wave devices. It supports 3 association groups which every group has one node support. Group1~Group3 support SWITCH\_BINARY\_REPORT.

For group 1, the Switch will report ON/OFF status of Relay1 and Relay2

For group 2, the Switch will report ON/OFF status of Relay1

For group 3, the Switch will report ON/OFF status of Relay2

#### 2-1 Auto report to Grouping 1 ~3(Maximum Node 1)

### 2-1-1 On/Off Event Report

When “on” or “off ” state has been changed (ex. Press S1 S2 or include on/off button), it will send Binary Switch Report to the nodes of Group1~3.

Binary Switch Report

ON:[**Command Class Switch Binary, Switch Binary Report, Value =0(255)0xFF**]  
 OFF:[**Command Class Switch Binary, Switch Binary Report, Value =0(0x00)**]

### 2-2 Multi Channel Command Class Version 3

PAN06 also support muti channel command class(version 3) , which include BINARY\_SWITCH\_GET, BINARY\_SWITCH\_SET

You may control or get report from 3 endpoint of PAN06

#### 2-2-1 BINARY\_SWITCH\_GET,

You may get the ON/OFF state from every endpoint, when endpoint set to 1 , PAN06 will reply ON(0xFF) either Relay 1 or Relay2 is ON, report OFF (0x00) when both Relay 1 and Relay2 OFF . If endpoint set to 2 , PAN06 will reply state of Relay1 . If endpoint set to 3 and PAN06 will reply state of Relay2

Below is a example show a source endpoint 5 send a get command to PAN06 endpoint 1

COMMAND_CLASS_MULTI_CHANNEL	
MULTI_CHANNEL_CMD_ENCAP	
Source End Point = 0x05	(this is the endpoint of command owner here we assume endpoint is 5 · if the owner doesn't support multi Channel this value will be 0)
(Bit Address+Destination End Point = 0x01)	(Bit Address =0 ; Destination End Point range from 1~3)
Command Class = 0x25	(Command_Class_Switch_Binary = 0x25)
Command =0x02	(Switch_Binary_Get = 0x02)

Below is the example show PAN06 report to last command

COMMAND_CLASS_MULTI_CHANNEL	
MULTI_CHANNEL_CMD_ENCAP	
Source End Point = 0x01	Since the endpoint is 1 so PAN06 will reply ON(0xFF) either Relay 1 or Relay2 is ON, report OFF (0x00) when both Relay 1 and Relay2 OFF
(Bit Address+Destination End Point = 0x05)	(Bit Address =0 ; Destination End Point)
Command Class = 0x25	(Command_Class_Switch_Binary = 0x25)

Command =0x03	(Switch_Binary_Report = 0x03)
Parameter 1 = 0xFF	(ON=0xFF , OFF=0x00)

### 2-2-2 BINARY\_SWITCH\_SET

By using BINARY\_SWITCH\_SET Command of Multi Channel Command Class Encapsulation Command, you can switch both Relay1 and Relay2 ON/OFF by setting endpoint to 1 or switch Relay1 ON/OFF by setting endpoint to 2 or switch Relay2 ON/OFF by setting endpoint to 3

The example of the command show that switch off relay1 of PAN06

COMMAND_CLASS_MULTI_CHANNEL	(this is the endpoint of command owner here we assume endpoint is 1 , if the owner doesn't support multi Channel this value will be 0)	
MULTI_CHANNEL_CMD_ENCAP		
Source End Point = 0x01		
(Bit Address+Destination End Point = 0x02)		(Bit Address =0 ; Destination End Point range1~3)
Command Class = 0x25		(Command_Class_Switch_Binary = 0x25)
Command =0x01		(Switch_Binary_Set = 0x01)
Parameter 1 = 0x00	(ON=0xFF , OFF=0x00)	

### 3. Z-Wave's Configuration

Configuration Parameter	Function	Size (Byte)	Value	Unit	Default	Description
1	Slected End Point	1	1-3		1	1 : Relay1 & Relay2 2 : Relay1 3 : Relay2
2	Edge or Pulse mode or Edge-Toggle mode	1	1-3		1	1 : Edge mode 2 : Pulse mode 3 : Edge-Toggle mode

#### 3-1 Selected Endpoint

If Controller not using Multi\_Channel command class to access the endpoint of PAN06, you may configure the endpoint value to react the Basic Command Class or Binary Switch Command Class.

##### 3-1-1 Selected Endpoint 1 : Default Selected Endpoint is 1

Set command	Relay state	
Basic Set or Binary_Switch_Set ON	Relay1 ON &	

	Relay2 ON	
Basic Set or Binary_Switch_Set OFF	Relay1 OFF & Relay2 OFF	

Get command	Relay state	Report to command sender
Basic_Get or Binary_Switch_Get	Relay1 ON or Relay2 ON	ON
Basic_Get or Binary_Switch_Get	Relay1 OFF & Relay2 OFF	OFF

### 3-1-2 Selected Endpoint 2

**Similar like** Selected Endpoint 1 but only relate to Relay1 and ignore Relay2

### 3-1-3 Selected Endpoint 3

**Similar like** Selected Endpoint 1 but only relate to Relay2 and ignore Relay1

### 3-2 Edge / Pulse / Edge-Toggle mode

Manual switch S1 and S2 can set to Edge mode or Pulse mode or Edge-Toggle mode , default value is Edge mode.

Edge mode: this mode is suitable for the bi stable wall switch that has indicator point on the switch, and the same position correspond to same state of relay1 and relay2 . if the PAN06 relay change the state because of receiving Z-Wave RF command, it may need two times of change (switch on to off or switch off to on) to let relay back to the correspond state.

Pulse mode: this mode is suitable for the toggle type wall switch to swap the state of Relay1 or Relay2

Edge-Toggle mode: this mode is suitable for the normal bi-stable switch, every time when change the state of the wall switch will also swap the state of Relay1 or Relay2

## 4. Command Classes

The Switch supports Command Classes including...

- \* COMMAND\_CLASS\_SWITCH\_BINARY
- \* COMMAND\_CLASS\_BASIC
- \* COMMAND\_CLASS\_MANUFACTURER\_SPECIFIC\_V2
- \* COMMAND\_CLASS\_VERSION
- \* COMMAND\_CLASS\_SWITCH\_ALL
- \* COMMAND\_CLASS\_ASSOCIATION\_V1
- \* COMMAND\_CLASS\_CONFIGURATION
- \* COMMAND\_CLASS\_MULTI\_CHANNEL\_V3
- \* COMMAND\_CLASS\_ALARM

## Troubleshooting

Symptom	Cause of Failure	Recommendation
The Switch not working and LED off	1. The Switch is not connect to the Main power 2. The Switch break down	1. Check power connections 2. Don't open up the Switch and send it for repair.

The Switch LED illuminating, but cannot control the ON/OFF Switch of the load attached	Check if the load connect into the Switch has its own ON/OFF switch	Set the ON/OFF switch of the load attached to ON
The Switch LED illuminating, but the Detector cannot control the Switch	1. Not carry out association 2. Same frequency interference	1. Carry out association 2. Wait for a while to re-try
LED keep flashing continuously, but cannot control	Overload occurs	Remove the load attached or check max. load cannot exceed 1500W~1650W

## Specification

Operating Voltage	100 ~240VAC 24-60V DC ±10%
Maximum Load	1500W X2 (220V) 800W X 2 (120V)
Range	Minimum 30 m in door 100m outdoor line of sight
Operating Temperature	0°C ~ 40°C
Frequency Range	PAN06-1 868.42 (EU) / PAN06-2 908.42(USA/Canada) / PAN06-3 922.5/923.9/926.3MHz (Taiwan/JP)MHz

\*\* Specifications are subject to change and improvement without notice.



FCC ID : RHHPAN06

## Warning:

- 1.Plug out to disconnect from power supply; Do not plug in line.
2. Do not exceed the max rating

## Disposal



This marking indicates that this product should not be disposed with other household wastes throughout the EU. To prevent possible harm to the environment or human health from uncontrolled waste disposal, recycle it responsibly to promote the sustainable reuse of material resources. To return your used device, please use the return and collection systems or contact the retailer where the product was purchased. They can take this product for environmental safe recycling.

Company of License Holder : Philio Technology Corporation

Address of License Holder : 8F.,No.653-2,Zhongzheng Rd., Xinzhuang Dist., New Taipei City 24257,Taiwan(R.O.C)

## FCC Interference Statement

This equipment has been tested and found to comply with the limits for a Class B digital device, pursuant to Part 15 of the FCC Rules. These limits are designed to provide reasonable protection against harmful interference in a residential installation. This equipment generates, uses and can radiate radio frequency energy and, if not installed and used in accordance with the instructions, may cause harmful interference to



radio communications. However, there is no guarantee that interference will not occur in a particular installation. If this equipment does cause harmful interference to radio or television reception, which can be determined by turning the equipment off and on, the user is encouraged to try to correct the interference by one of the following measures:

- Reorient or relocate the receiving antenna.
- Increase the separation between the equipment and receiver.
- Connect the equipment into an outlet on a circuit different from that to which the receiver is connected.
- Consult the dealer or an experienced radio/TV technician for help.

This device complies with Part 15 of the FCC Rules. Operation is subject to the following two conditions:

- (1) This device may not cause harmful interference, and
- (2) This device must accept any interference received, including interference that may cause undesired operation.

FCC Caution: Any changes or modifications not expressly approved by the party responsible for compliance could void the user's authority to operate this equipment.

This transmitter must not be co-located or operating in conjunction with any other antenna or transmitter.