

PAN08-1/-2/-3 Roller shutter controller

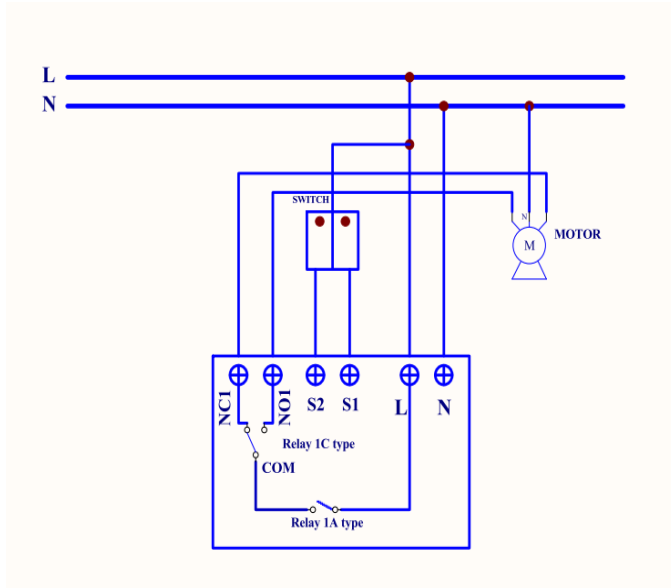
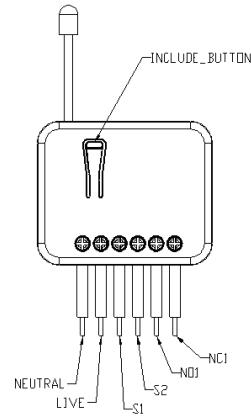
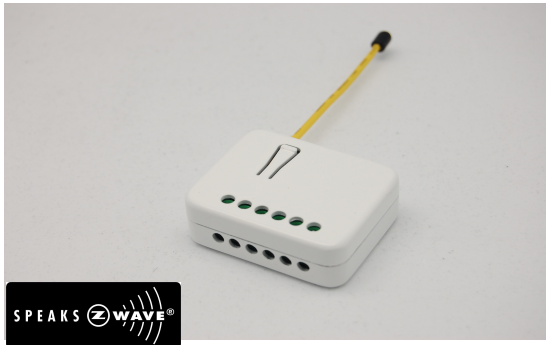

Fig 1. Assembling

The in-wall Roller Shutter Controller is designed to switch rise/lower roller shutter connected to its terminals using radio waves, controllers and a push button directly

connected to this Roller Controller.

This in-wall Roller Shutter Controller is a transceiver which is a Z-Wave™ enabled device and is fully compatible with any Z-Wave™ enabled network. Slim design let the Controller can easily hide itself into the wall box and that will be good for the house decoration.

The new smart relay calibration technology can reduce the inrush current caused by the load and let the module work perfectly with many kind of Roller Shutter.

This in-wall Roller Shutter Controller is able to detect position of the Shutter by using the patterned power measuring method, so it can be remote controlled not only fully up or down , but also can be adjusted to ex. 30% or 50%. And when manual controlled by push button, the controller also can memorize the position and send the new shutter position to its controller (ex. IP-Gateway).

Adding to Z-Wave™ Network

In the front casing, there is an include button with LED indicator below which is used to carry out inclusion, exclusion, reset or association. When first power is applied, its LED flashes on and off alternately and repeatedly at 2-second intervals. It implies that it has not been assigned a node ID and cannot work with Z-Wave enabled devices.

Auto Inclusion

The function of auto inclusion will be executed as long as the PAN08 does not have Node ID and just connect the PAN08 to main power.

Note: Auto inclusion timeout is 4 minute during which the node information of

explorer frame will be emitted once every 5 seconds. Unlike “inclusion” function as shown in the table below, the execution of auto inclusion is free from pressing the Include button on the PAN08.

The table below lists an operation summary of basic Z-Wave functions. Please refer to the instructions for your Z-Wave™ Certificated Primary Controller to access the Setup function, and to include/exclude/associate devices

Function	Description	LED Indication
No node ID	The Z-Wave Controller does not allocate a node ID to the PAN08.	2-second on, 2-second off
Inclusion	1. Have Z-Wave Controller entered inclusion mode.	One press one flash
	2. Pressing Include button three times within 1.5 seconds will enter inclusion mode.	
Exclusion	1. Have Z-Wave Controller entered exclusion mode.	One press one flash
	2. Pressing Include button three times within 1.5 seconds will enter exclusion mode.	
	Node ID has been excluded.	2-second on, 2-second off
Reset	1. Pressing Include button three times within 1.5 seconds will enter inclusion mode.	One press one flash
	2. Within 1 second, press Include	

	button again for 5 seconds until LED is off.	
	3. IDs are excluded.	2-second on, 2-second off
Association	1. Have Z-Wave Controller entered association mode. Or Pressing Include button three times within 1.5 seconds will enter association mode	One press one flash
	2. There are 1 group (Group 1) for the PAN08	
✘Including a node ID allocated by Z-Wave Controller means inclusion. Excluding a node ID allocated by Z-Wave Controller means exclusion. ✘Failed or success in including/excluding the node ID can be viewed from the Z-Wave Controller.		

LED Indication

To distinguish what mode the PAN08 is in, view from the LED for identification.

State Type	LED Indication
Motor activate	No matter up or down, close or open, Led will flash every second while Motor activate.
No node ID	Under normal operation, when the PAN08 has not been allocated a node ID, the LED flashes on and off alternately at 2-second intervals. By pressing S1 S2 or Include button, it will stop flashing temporarily. However, after disconnect and reconnect the PAN08, the LED will flash on and off alternately at 2-second intervals.

Overload	When overload state occurs, the PAN08 is disabled of which LED flashes on and off alternately at 0.5 second intervals. Overload state can be cleared by disconnect and reconnect the PAN08 to the main power
----------	--

Choosing a Suitable Location

1. Do not locate the PAN08 facing direct sunlight, humid or dusty place.
2. The suitable ambient temperature for the PAN08 is 0°C~40°C.
3. Do not locate the PAN08 where exists combustible substances or any source of heat, e.g. fires, radiators, boiler etc.
4. After putting it into use, the body of PAN08 will become a little bit hot of which phenomenon is normal.

Installation and operation

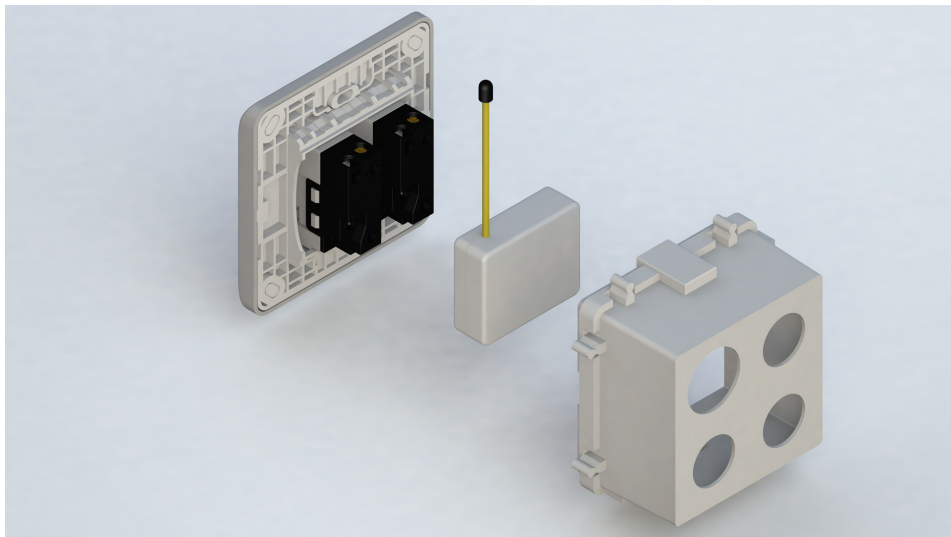

1. put the in wall PAN08 into a wall box and connect the AC power wire L,N to PAN08 connector L, N.
2. Connect the wall switch to the PAN08 as Fig1 .
3. It is important to carry out a shutter calibration process before you control the shutter to move. Press inclusion button over 3 seconds and release before the 6th second, the roller shutter controller will start the shutter calibration process. The process is composed of three continue stages. The shutter move to the TOP in first stage, and move to the BOTTOM in second stage, and move to the TOP again in third stage. Then PAN08 will know the total range of UP and DOWN.
4. During the shutter calibration process, any emergencies happen you can press and release the include button to stop the process
5. If user found the direction is reverse, this may because the wrong connection of NC and NO to the motor, please change NC and NO connection and execute calibration process again.

6. To manually switch up and down of the shutter, simply press S1 or S2 .
7. PAN08 built in meter function and can read the Watt , kWh, V(Voltage), I(Current) , PF(Power Factor) of the load by using Z-Wave command class, user can **set a threshold watt to get the warning** caused by abnormal operation
8. PAN08 have overload protection function, and can help to prevent short circuit caused by load.

Programming

1. Basic Command Class

The PAN08 will respond to BASIC and BINARY commands that are part of the Z-Wave system.

1.1 BASIC_GET

When PAN08 receive Basic Set Command , it will send Basic Report Command to report the position of the curtain . When the report value is 0x00, that mean the Shutter is bottom down, if the report value is 0xFF or 0x63 that mean the Shutter is at the top, any other value between 0x01~0x62 imply Shutter at 1%~99% position ; But if report value is 0xFE means the position is unknown .

Basic Get Command: **[Command Class Basic, Basic Get]**

Basic Report Command :

[Command Class Basic, Basic Report, Value = 0x00 (BOTTOM)]

[Command Class Basic, Basic Report, Value = 0x01~0x62 (Between BOTTOM and TOP)]

[Command Class Basic, Basic Report, Value = 0xFE (UNKNOWN)]

[Command Class Basic, Basic Report, Value = 0x63/0xFF (TOP)]

1-2 BASIC_SET

PAN08 can only accept Basic Set Command which value is either (0x00)Bottom or Top (0x63/0xFF) , other value is not acceptable

[Command Class Basic, Basic Set, Value = 0x63 或 0xFF] control the shutter to the top (0xFF) .

[Command Class Basic, Basic Set, Value = 0x00(0)] control the shutter to the bottom(0x00) .

2 Binary Switch Command Class

2-1 BINARY_SWITCH_GET,

When PAN08 receive Binary Switch Get Command, it will send Binary Switch Report Command to report the position of the curtain. When the report value is 0x00, that mean the Shutter is bottom down, if the report value is 0xFF that mean the Shutter is at the top. But if report value is 0xFE means the position is unknown.

Binary Switch Get Command :

[Command Class Binary Switch, Binary Switch Get]

Binary Switch Report Command :

[Command Class Binary Switch, Binary Switch Report, Value = 0x00(BOTTOM)]

[Command Class Binary Switch, Binary Switch Report, Value = 0xFE(UNKNOWN)]

[Command Class Binary Switch, Binary Switch Report, Value = 0xFF(TOP)]

2-2 BINARY_SWITCH_SET

PAN08 can only accept Binary Switch Set Command which value is either (0x00) Bottom or Top (0xFF) , other value is not acceptable .

[Command Class Binary Switch, Binary Switch Set, Value = 0xFF(255)]

control the shutter to the top (0xFF) . But if the shutter is on the way down, this command will stop the shutter .

[Command Class Binary Switch, Binary Switch Set, Value = 0x00(0)]

control the shutter to the bottom(0x00) . But if the shutter is on the way up, this command will stop the shutter .

3-1 MULTILEVEL SWITCH SET:

PAN08 can only accept Multilevel Switch Set Command which value is either (0x00)Bottom or Top (0x63 or 0xFF) , other value is not acceptable .

[Command Class Multilevel Switch, Multilevel Switch Set, Value = 0x63 or 0xFF(255)] control the shutter to the top (0xFF) .

[Command Class Multilevel Switch, Multilevel Switch Set, Value = 0x00(0)] control the shutter to the bottom(0x00) .

3-2 MULTILEVEL SWITCH GET:

When PAN08 receive Multilevel Switch Get Command, it will send Multilevel Switch Report Command to report the position of the shutter. When the report value is 0x00, that mean the shutter is bottom down, if the report value is 0xFF or 0x63 that mean the shutter is at the top, any other value between0x01~0x62 imply shutter at 1%~99% position : But if report value is 0xFE means the position is unknown.

Switch Multilevel Get Command :

[Command Class Multilevel Switch, Multilevel Switch Get]

Multilevel Switch Report Comman :

[Command Class Multilevel Switch, Multilevel Switch Report, Value = 0x00(BOTTOM)]

[Command Class Multilevel Switch, Multilevel Switch Report, Value = 0x01~0x62(Between BOTTOM and TOP)]

[Command Class Multilevel Switch, Multilevel Switch Report,

Value = 0xFE(UNKNOWN)]

[Command Class Multilevel Switch, Multilevel Switch Report,

Value = 0x63/0xFF(TOP)]

3-3 MULTILEVEL SWITCH START LEVEL CHANGE:

This is the command which user can move the shutter to the particular position ex. 60% of total range

[Command Class Multilevel Switch, Multilevel Switch Start Level Change, Up/Down Value , Inc/Dec Value, Step Size Value] °

3-3.1 Up/Down Bit :

If Up/Down Bit=0x00 Shutter move up ;

If Up/Down Bit=0x01 Shutter move down ;

If Up/Down Bit=0x03 no move

3-3.2 Inc/Dec Bit :

If Inc/Dec Bit=0x00 means New Step_Size = Now Step_Size + Step_Size ;

If Inc/Dec Bit=0x01 means New Step_Size = Now Step_Size - Step_Size ;

If Inc/Dec Bit=0x03 means New Step_Size = Now Step_Size

3-3.3 Step_Size :

Range from 0x00~0x63 or 0xFF, default value=50, and the meaning of 0x63 and 0xFF is 100% of total range. If the Now Step_Size + Step_Size >100, the new Step_Size will stay at 100 , if the Now Step_Size - Step_Size <0 , the New Step_Size will stay at 0

Example 1 : If user want shutter move up , and the distance is 60% of total range(assume the now Step_Size= 50)

Command Class Multilevel Switch	
Multilevel Switch Start Level Change	
Up/Down = 0x00	(UP = 0x00)
Inc/Dec = 0x00	(Increment = 0x00 : Step_Size = 50+10 = 60)
Step_Size = 10	This value represent how many the new step_size want to increase or decrease

Example 2 : If user want shutter move down , and the distance is 50% of total range(assume the now Step_Size= 50)

Command Class Multilevel Switch	
Multilevel Switch Start Level Change	
Up/Down = 0x01	(Down = 0x01)
Inc/Dec = 0x03	(No Inc/Dec = 0x03 : not change Step_Size value , Step_Size = 50)
Step_Size = 0	This value represent how many the new step_size want to increase or decrease, when Inc/Dec = 0x03 please set this value to 0)

Example 3 : If User not go to change shutter position but only change Step_Size to 40%(assume the now Step_Size= 50)

Command Class Multilevel Switch	
Multilevel Switch Start Level Change	
Up/Down = 0x03	(No Up/Down motion = 0x03)
Inc/Dec = 0x01	(Decrement = 0x01 : Step_Size = 50-10 = 40)
Step_Size = 10	This value represent how many the new step_size want to increase or decrease

ATT.1. Ignore_Start_Level、 Start_Level、 Dimming_Duration can not be used

2. PAN08 can not control the speed of motor.

3-3.4 MULTILEVEL SWITCH STOP LEVEL CHANGE:

When receive Multilevel Switch Stop Level change Command PAN08 will stop the motor ◦

4 Z-wave's Groups introduction (Association Command Class Version 1)

There is only one group called Group1 , there is only one node for Group1 which support MULTILEVEL_SWITCH_REPORT 、 METER_REPORT_COMMAND_V3 、 ALARM_REPORT ◦

4-1 Report the shutter position :

Every time when user press S1 or S2 and let shutter to move, PAN08 will report the position status to controller, and at the moving process when change over 10% PAN08 will send Multilevel Switch Report to Group 1 also.

Multilevel Switch Report :

Ex. Report position at 30%

[Command Class Multilevel Switch , Multilevel Switch Report , Value = 30(%)]

4-2 Meter Command Class :

The Switch will report its (1) instant Power Consumption (Watt) or (2) accumulated power consumption(KWH) or (3) AC load Voltage (V) or (4) AC load current (I) (5) load power factor (PF) to Z-Wave Controller after receive the Meter Get Command from Z-Wave Controller.

When the power consumption of load vary over 5%, it will send Meter report to the nodes of Group as well

4-2.1 Instant Power Consumption (Watt) of Switch

When receiving Meter Get Command, it will report Meter Report Command to the node asked.

Meter Get Command: [Command Class Meter, Meter Get, Scale =0x02(W)]

Meter Report Command: [Command Class Meter , Meter Report , scale(bit 2) +Rate Type +Meter Type , Precision + Scale(bit 1,0)+ Size , Meter Value 1 , Meter Value 2 , Meter Value 3 , Meter Value 4]

Rate Type = 0x01

Meter Type = 0x01

Precision = 1

Scale = 0x02(W)

Size = 4 Bytes (Meter Value)

Meter Value 1 = (W) MSB

Meter Value 2 = (W)
Meter Value 3 = (W)
Meter Value 4 = (W)LSB

Example:

Meter Value 1 = 0x00 (W)

Meter Value 2 = 0x00 (W)

Meter Value 3 = 0x03 (W)

Meter Value 4 = 0xEA (W)

Meter(W) = Meter Value 3 *256 + Meter Value 4 = 100.2W

4-2.2 Accumulated Power Consumption (KW/h)

When receiving Meter Get Command, it will report Meter Report Command to the node asked.

Meter Get Command: [**Command Class Meter, Meter Get, Scale = 0x00 KW/h**]

Meter Report Command: [**Command Class Meter , Meter Report , scale(bit 2) +Rate Type +Meter Type , Precision + Scale(bit 1,0)+ Size , Meter Value 1 , Meter Value 2 , Meter Value 3 , Meter Value 4**]

Rate Type = 0x01

Meter Type = 0x01

Precision = 2

Scale = 0x00 (KWh)

Size = 4 bytes (Meter Value)

Meter Value 1 = (KWh) MSB

Meter Value 2 = (KWh)

Meter Value 3 = (KWh)

Meter Value 4 = (KWh) LSB

Example:

Scale = 0x00 (KWh)

Precision = 2

Size = 4 Bytes (KW/h)

Meter Value 1 = 0x00(KWh)

Meter Value 2 = 0x01(KWh)

Meter Value 3 = 0x38(KWh)

Meter Value 4 = 0xA3(KWh)

Accumulated power consumption (KW/h) = (Meter Value 2*65536) + (Meter Value 3*256) + (Meter Value 4) = 800.35 (KW/h)

4-2.3 AC load Voltage (V)

When receiving Meter Get Command, it will report Meter Report Command to the node asked.

Meter Get Command: [**Command Class Meter, Meter Get, Scale =0x04(V)**]

Meter Report Command:
[**Command Class Meter , Meter Report , scale(bit 2) +Rate Type +Meter Type , Precision + Scale(bit 1,0)+ Size , Meter Value 1 , Meter Value 2**]

Rate Type = 0x01

Meter Type = 0x01

Precision = 1

Scale = 0x04(V)

Size = 2 Bytes (Meter Value)

Meter Value 1 = High Byte (V)

Meter Value 2 = Low Byte (V)

Example:

Scale = 0x04 (V)

Precision = 1

Size = 2 (2 Bytes of V)

Meter Value 1 = 0x09(V)

Meter Value 2 = 0x01(V)

AC load Voltage = (Meter Value 1*256) +(Meter Value 2)= 230.5 (V)

4-2.4 AC load current (I)

When receiving Meter Get Command, it will report Meter Report Command to the node asked.

Meter Get Command: **[Command Class Meter, Meter Get, Scale =0x05(I)]**

Meter Report Command:

[Command Class Meter , Meter Report , scale(bit 2) +Rate Type +Meter Type , Precision + Scale(bit 1,0)+ Size , Meter Value 1 , Meter Value 2]

Rate Type = 0x01

Meter Type = 0x01

Precision = 2

Scale = 0x05(I)

Size = 2 Bytes (Meter Value)

Meter Value 1 = High Byte (I)

Meter Value 2 = Low Byte (I)

Example:

Scale = 0x05 (I)

Precision = 2

Size = 2 (2 Bytes of I)

Meter Value 1 = 0x01(I)

Meter Value 2 = 0x21(I)

AC load current = (Meter Value 1*256) +(Meter Value 2)= 2.89 (A)

4-2.5 load power factor (PF)

When receiving Meter Get Command, it will report Meter Report Command to the node asked.

Meter Get Command: **[Command Class Meter, Meter Get, Scale =0x06(PF)]**

Meter Report Command:
[Command Class Meter , Meter Report , scale(bit 2) +Rate Type +Meter Type , Precision + Scale(bit 1,0)+ Size , Meter Value 1]

Rate Type = 0x01

Meter Type = 0x01

Precision = 2

Scale = 0x06(PF)

Size = 1 Bytes

Meter Value 1

Example:

Scale = 0x06 (PF)

Precision = 2

Size = 1 (1 Byte of PF)

Meter Value 1 = 0x63(PF)

Load power factor (PF) = Meter Value 1 = 0.99

4-2.6 reset Accumulated Power Consumption (KWh)

This command is to reset the Accumulated Power Consumption (KWh) to 0

Meter Reset Command :

[Command Class Meter, Meter Reset]

4-3 Alarm Report Command :

When PAN08 detect Overload , it will send Alarm_Report to Group1 , Alarm Level=0xFF . When receive Alarm_Get command and the PAN08 not in overload status , it will send Alarm_Report , Alarm Level=0x00 .

4-3.1 Alarm Report :

[Command_Class_Alarm, Alarm_Report, Alarm Type = 0x08, Alarm Level = 0xFF (Overload)]

[Command_Class_Alarm, Alarm_Report, Alarm Type = 0x08, Alarm Level = 0x00 (Normal)]

5 Z-Wave's Configuration

Configuration Parameter	Function	Size (Byte)	Value	Unit	Default	Description
1	Watt Meter Report Period	2	0x01-0x7FFF	5s	720	5*720s=3600s=1 hour
2	KWH Meter	2	0x01-0x7FFF	10min	6	6*10min= 1 hour

	Report Period					
3	Threshold of Watt for Load Caution	2	10-1100	1watt	1100	
4	Threshold of KWH for Load Caution	2	1-10000	1KWh	10000	

5-1 Watt Meter Report Period:

If the setting is configured for 1hour (set value =720), the PAN08 will report its instant power consumption every 1 hour to the node of correspond Group. The maximum interval to report its instant power consumption is 45 hours (5s*32767/3600=45hr). Default value is 1 hour

5-2 KWH Meter Report Period:

If the setting is configured for 1hour (set value =6), the PAN08 will report its Accumulated Power Consumption (KW/h) every 1 hour to the node of correspond Group. The maximum interval to report its Accumulated Power Consumption (KW/h) is 227.55 days (10min*32767/1440=227.55 days). Default value=1 hour

5-3 Threshold of Watt for Load Caution

This is a warning when the wattage of load over the preset threshold value, If the setting value is 1100, when the load wattage over this value, PAN08 will send Watt Meter Report command to the node of correspond Group. Default value=1100W

5-4 Threshold of KWh for Load Caution

This is a warning when the KWh of load over the preset threshold value, If the setting value is 10000, when the Accumulated Power Consumption of Relay1 or Relay2 over this value, PAN08 will send KWh Meter Report command to the node of correspond Guoup, minimum value is 1KWh and default value is 10000 kWh

6. Command Classes

The Switch supports Command Classes including...

- * COMMAND_CLASS_SWITCH_BINARY
- * COMMAND_CLASS_BASIC
- * COMMAND_CLASS_MANUFACTURER_SPECIFIC_V2
- * COMMAND_CLASS_VERSION
- * COMMAND_CLASS_ASSOCIATION
- * COMMAND_CLASS_METER_V3
- * COMMAND_CLASS_CONFIGURATION
- * COMMAND_CLASS_SWITCH_MULTILEVEL_V3
- * COMMAND_CLASS_ALARM

Troubleshooting

Symptom	Cause of Failure	Recommendation
---------	------------------	----------------

The PAN08 not working and LED off	1. The PAN08 is not connect to the Main power 2. The PAN08 break down	1. Check power connections 2. Don't open up the PAN08 and send it for repair.
The shutter move direction is reverse	Wrong connection of NC and NO to the motor	Swap the NC NO connection
PAN08 LED light work fine But can not control	1. No association setting 2. Same frequency interference	1. Carry out association 2. Wait for a while to re-try

Specification

Operating Voltage	100 ~240VAC
Maximum Load	Resistive load 1100W/600W/550W(EU/US/TW) max
Range	Minimum 30 m in door 100m outdoor line of sight
Operating Temperature	0°C ~ 40°C
Frequency Range	PAN08-1 868.42 (EU) / PAN08-2 908.42(USA/Canada) / PAN08-3 922.5/923.9/926.3MHz (Taiwan/JP)MHz

** Specifications are subject to change and improvement without notice.



FCC ID : RHHPAN08

Warning:

- 1.Plug out to disconnect from power supply; Do not plug in line.
2. Do not exceed the max rating

Disposal



This marking indicates that this product should not be disposed with other household wastes throughout the EU. To prevent possible harm to the environment or human health from uncontrolled waste disposal, recycle it responsibly to promote the sustainable reuse of material resources. To return your used device, please use the return and collection systems or contact the retailer where the product was purchased. They can take this product for environmental safe recycling.

Company of License Holder : Philio Technology Corporation

Address of License Holder : 8F.,No.653-2,Zhongzheng Rd., Xinzhuang Dist., New Taipei City 24257,Taiwan(R.O.C)

FCC Interference Statement

This equipment has been tested and found to comply with the limits for a Class B digital device, pursuant to Part 15 of the FCC Rules. These limits are designed to provide reasonable protection against harmful interference in a residential installation. This equipment generates, uses and can radiate radio frequency energy and, if not installed and used in accordance with the instructions, may cause harmful interference to radio communications. However, there is no guarantee that interference will not occur in a particular installation. If this equipment does cause harmful interference to radio or television reception, which

can be determined by turning the equipment off and on, the user is encouraged to try to correct the interference by one of the following measures:

- Reorient or relocate the receiving antenna.
- Increase the separation between the equipment and receiver.
- Connect the equipment into an outlet on a circuit different from that to which the receiver is connected.
- Consult the dealer or an experienced radio/TV technician for help.

This device complies with Part 15 of the FCC Rules. Operation is subject to the following two conditions:

- (1) This device may not cause harmful interference, and
- (2) This device must accept any interference received, including interference that may cause undesired operation.

FCC Caution: Any changes or modifications not expressly approved by the party responsible for compliance could void the user's authority to operate this equipment.

This transmitter must not be co-located or operating in conjunction with any other antenna or transmitter.