

PAN27

Smart Home DIN Rail box

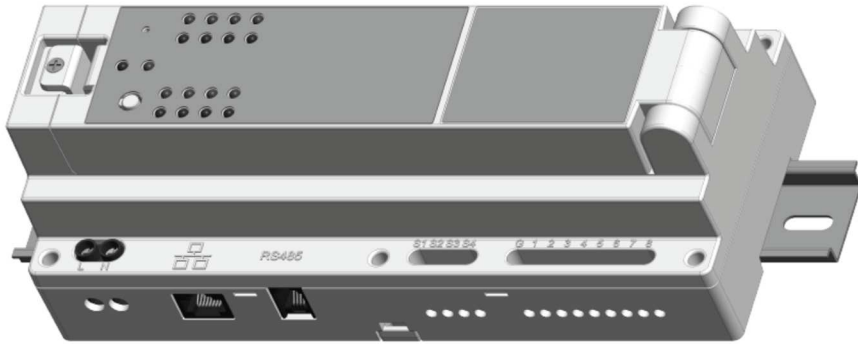

Note: The power cord must meet 1.25mm² or 16AWG or better

This Smart home din rail mounted box with dongles is “simply fabulous”

Smart home DIN rail box looks ok, but it's really one lean mean machine boasting 8 output slots that can control just about anything with plug n' play dongles. The 8 outputs correspond to 8 inputs, so the unit can be used from the start without programming. Four additional inputs can be used to run scenarios without the app, and the input method can also be easily changed from push button to switch.

- On/Off
- Dimmer
- Dry contact

Compatible with just about anything

By default Smart home din rail box communicates via RJ11 or RJ45 (WiFi). By simply adding a dongle to one of the two USB ports, the box supports Z-Wave and ZigBee. (Note: For FCC ID: RHPAN27, it supports WLAN 2.4G mode only without Z-Wave and Zigbee function.) A one-time installation of the all-in-one box ensures support and compatibility with just about any system or device from any manufacturer.

Safety Precautions and Installation

- Disconnect from supply before removing
- Avoid installing the unit in storming or raining weather.
- Be sure to isolate or switch off power source before installing or maintenance.
- Do ensure that the power supply circuit protected by a 16A circuit breaker or suitable equivalent fuse.
- Make sure to protect each external power circuit 5A (relay dongle) by using either circuit breaker or equivalent suitable fuse.

IMPORTANT

- Installation and any maintenance must be performed by skilled technicians who are informed about the standards and technical requirements of the appliance and its proper installation. Installing or changing dongle shall also be performed by skilled technicians. Disconnect from supply before any maintenance or serving. The accessible parts to user is LED display plate after installation.
- Check your local codes as they apply to your situation. If the house wiring is of aluminum, consult with an electrician about proper wiring methods.

Before proceeding with the installation, TURN OFF THE POWER TO THE LIGHTING CIRCUIT AT THE CIRCUIT BREAKER OR FUSE BOX TO AVOID ELECTRICAL SHOCK.

Security

Before making any connections, please read these instructions carefully.

Never remove the plastic base from DIN rail.

Do not touch live parts. High voltages present in module.

To access the interior of this equipment must first be disconnected from the mains.

Connect to the internet.

- Go to Settings, Wi-Fi, choose your own Wi-Fi SSID, and connect it.
- Once you connect to Wi-Fi, open the app

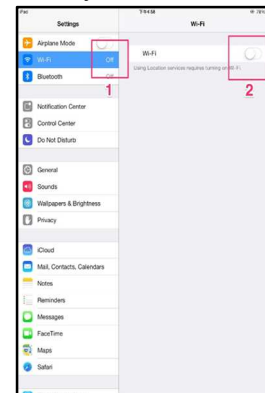

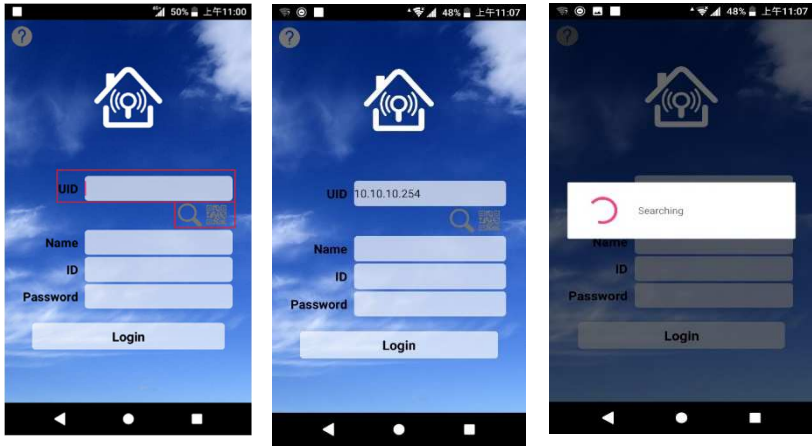

• Add UID: Can enter 10.10.10.254 or press Search or press QR Code to scan the QR Code to set up the gateway address.

- Name: arbitrary input
- ID: admin
- Password: 888888

Add your devices

• In the Device page, press Plus Gear→ Include Device to add Z-wave or ZigBee devices. (Remember to activate the include mode of your device by flipping three times the trigger on it.)

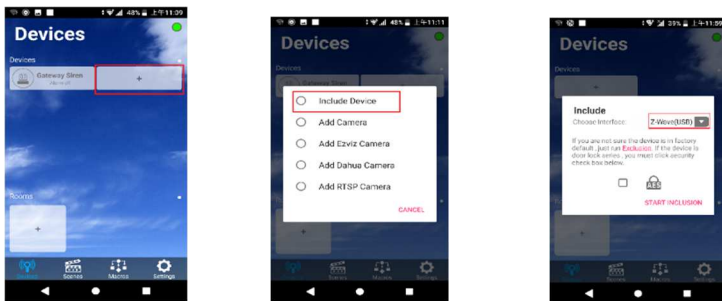

Add IP Cam

• In the Device page, press Plus Gear→ Add IP Cam→ QR Code to add IP Cam by scanning the QR Code with camera.

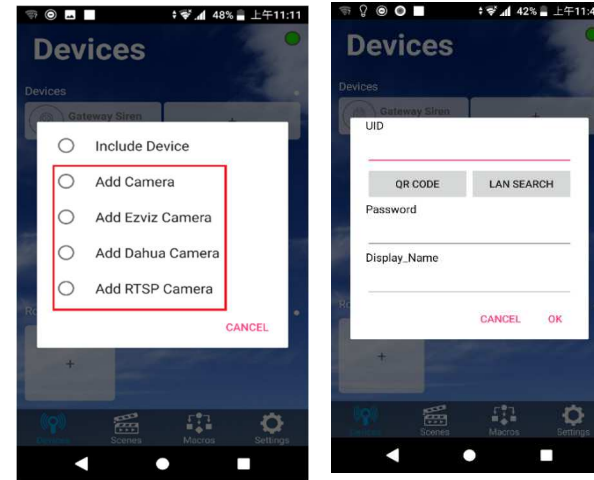

Add a room

• Press Add new Room in the Device page to add a new room, enter the name of the room as you like.

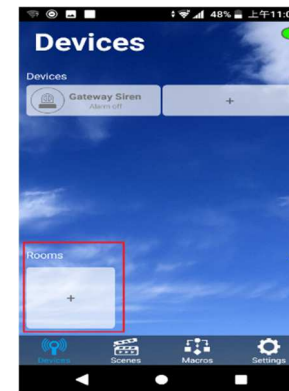

Scene

• Scene can set the room ambiance quickly. It can help you to have a better experience at the special moment.



Macro

Still worry about your flat security?

Macro is just like your 24-7 personal home guard.

It secures your flat. Just set the reactive you wishes, it obeys your orders faithfully.



Overview

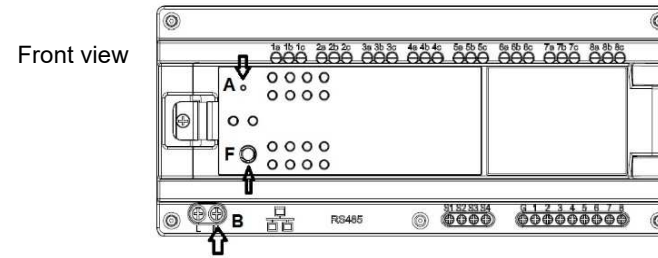

Front view

A. Reset
B. AC Power input

D. RJ45 Ethernet port
E. RJ 22 port
F. Learn Key

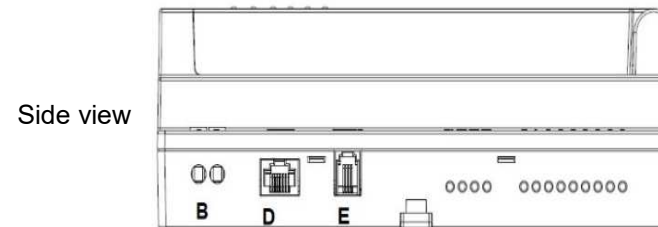

Side view

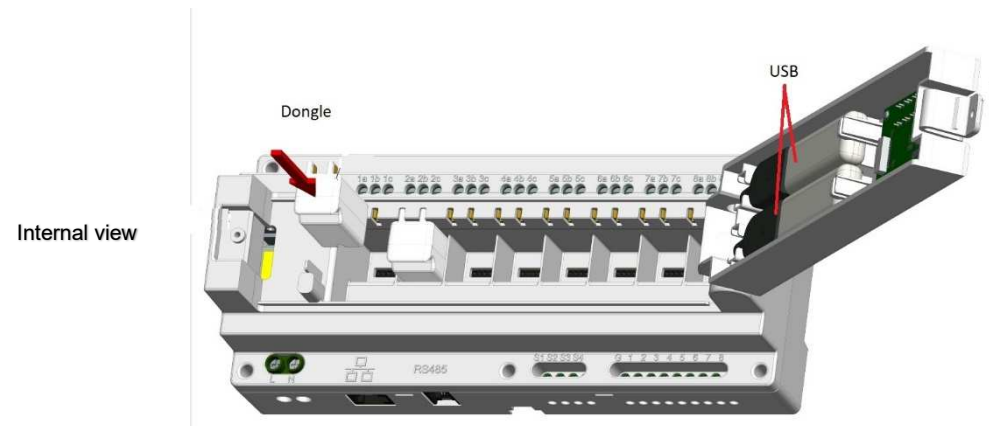

Internal view

Wire Connection

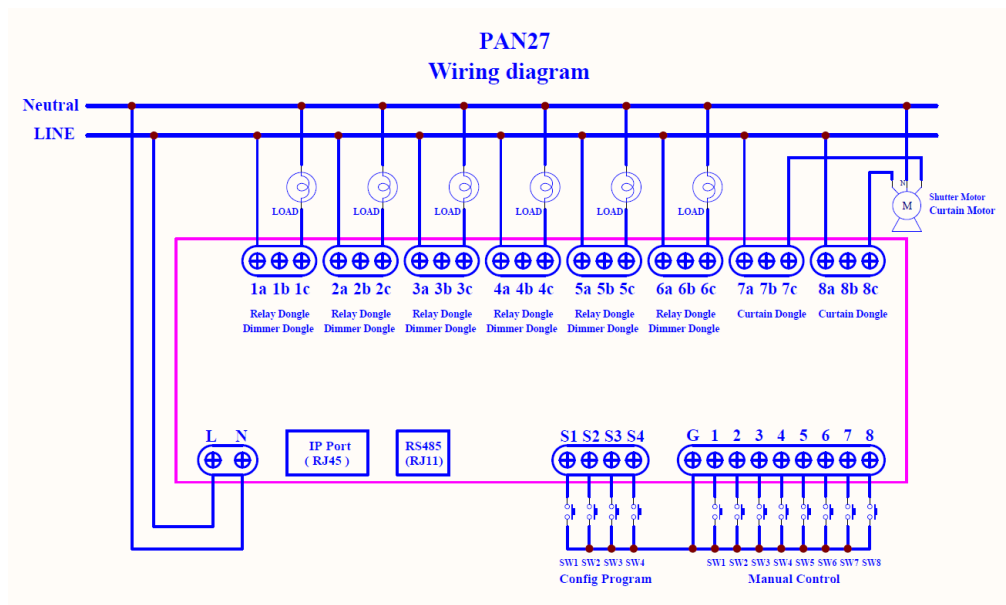

To start using PAN27 Smart Home Relay/dimmer Box, please connect the device to power and LAN sockets, as shown below. Connect power cable to the mains, and network cable to LAN socket in your router (PAN27 requires an outside router or you can only control the system at your home).

Communication setup

PAN27 is shipped with the following default parameters:

IP address: Assigned by DHCP

Login: admin

Web password: 888888

APP web

Installing the companion APP

1. Connect your phone to Internet, login or sign up for google account or APP ID
2. Launch Play store or APPLE store
3. Search for Philio's Home Mate, then install the companion APP.
4. Click the APP and you can use local LAN search or QR code to find PAN27
5. Please use ID: admin password: 888888 to login the APP
6. The detail of APP, please see the APP manual.

Table of connections

Interface	L-N	AC100-240V
	S1-S4	Control scenes
	G	Ground
	1~8	Control On/Off, Dimming,
	RJ11	4P2C, for RS485 interface
	RJ45	10/100 Base-T Ethernet
	1a1b1c, 2a2b2c, 3a3b3c, 4a4b4c, 5a5b5c, 6a6b6c, 7a7b7c, 8a8b8c	For signal
USB	For Z-wave, ZigBee dongle (operational)	
Button	Learn Key	Z-wave include/exclude
	Reset	Reset to default
LED indicator	Power	ON/OFF
	1-8	Indicate dongle status (Relay/Dimmer dongles)
	Net	Net

The functions of PAN27 :

1. PAN27 can install 8 independent Relay or Dimmer dongle and can hot plugin.
2. PAN27 can use Zigbee/Z wave USB Dongle (operational).
3. PAN27 can control the PAN26 with RJ11 and PAN27(set as slave).
4. PAN27 each relay dongle can bear current 5A
5. PAN27 each dimmer dongle can bear current 0.7A

The key on the body

TEMP key:

For safety issue, you must close the top cover and start to work. When you open the cover, TEMP key will be trigger and all module will be off and cannot be controlled until you close the cover.

Reset key:

You can reset all the PAN27 parameter include Z-Wave/Zigbee device by press by press 5 seconds

The external Switch

Relay dongle can connect the wall switch as Edge/Pulse/Toggle mode

Each dongle can detect the loading. When detect is overload, the module switch will be set to off and no more current.

About LED indicator, if no module, LED is off.

When the dongle with current, the LED will be on/green.

When the dongle without current, the LED will be off/red.

How to add the device

You can insert the dongle or use Zigbee/Z-Wave to add the device.

The dongle will show on main screen directly and you can press to do actions like Relay on/off, Dimmer adjust moving.

If you are using Zigbee/Z-Wave device, you can press the + and set PAN27 into inclusion mode the press the device temper key to add to PAN27.

The detail operation of the device, you should refer the manual of the device.

Gateway WIFI Setting

Go to Setting Tab and click “Gateway Information”, then press  icon.

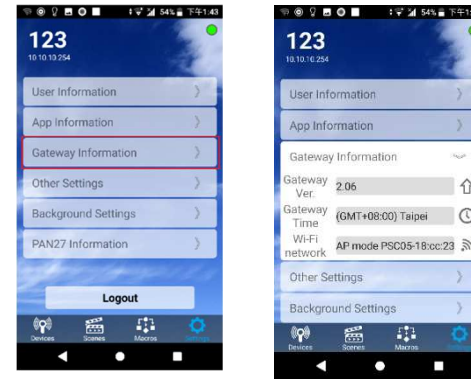

The default is AP mode and if you want use STA mode please do as step by step.

Programming

When installing the relay dongle, it is necessary to set it in groups of two and insert it in the specified grouping position.

Ontology button:

TEMP key: In the normal working mode, the cover needs to be closed. For safety reasons, when the cover is opened, the TEMP key will turn off the full Module and will not accept any control until the cover is attached.

Learn key: press three times include / press five to exclude

Reset key: reset the set value

External Key Switch :

PAN27 can connect 12 groups of manual switches, which are 8 groups of control switches and 4 groups of situational switches.

When the corresponding module of the control switch is the Relay Module, it can be set to Edge mode, Pulse mode or Edge-Toggle mode. The Default value is Edge-Toggle mode.

Edge mode :

Edge mode is suitable for switches that normally use a fixed position. When the switch is held down, it can control Relay1 or Relay2 to be ON. When the switch is held up, it can control Relay1 or Relay2 to OFF.

Pulse mode :

The Pulse mode is suitable for releasing the automatic pop-up switch. Pressing the hand and then releasing the switch can toggle the Relay1 or Relay2 to ON (or OFF); press the hand again to release the switch, and then toggle the Relay1 or Relay2 ON again. OFF state; and so on.

Edge-Toggle mode :

The Edge-Toggle mode can only be used on switches that are normally fixed positions. Toggle control of Relay1 or Relay2 is ON (or OFF) each time the switch is pressed (being held or tilted); the hand is switched again (turned or pressed). , then again toggle the ON/OFF state of Relay1 or Relay2; and so on.

Control switch:

Dongle	action	directions
RELAY	Toggle mode	When the switch has a switch, Relay will be anti-action, ON become OFF, OFF become ON
	Pulse mode	When the switch is pressed once (Press → Release), Relay will be anti-action, only press not released
	Edge mode	When the switch is switched on, only Relay ON action, when releasing, only the Relay OFF action

DIMMER	Long press	When the button is pressed for more than 1 second and is not released, it is judged as a long press. The dimmer will start dimming until the button is released. The dimming will be stopped, and the state will be stopped at the time of release.
	Short press	When the key is pressed within 1 second, one press (press → release), it is judged as a short press. If the current LEVEL is not 0%, it will be moved to 0%, and the current LEVEL is 0%, then it will move to the previous LEVEL.

Current Detection:

When the Module is in the normal working mode, it has a load detection function, that is, detects the power load status of the Module.

When an "overload" condition is detected, the Module switch is immediately set to "OFF" and the load power is permanently switched off.

In the overload condition, the Module no longer accepts the control (including the signal of the Module button and the RF control ON), and must wait until the Device releases the Error state caused by the overload and operates normally.

LED indicator:

General mode: When the Module enters the normal working mode, if there is a control switch or RF command control module, the LED will show the Module state, when there is electricity conduction, the state is ON green, the state is OFF when the power is off. red light.

When no Module is installed in this position, the LED indicator is completely off.

POWER signal: When there is a normal power supply, the light is always on, and it flickers when there is a network connection.

Connection Signal: When the connection status of PAN27 is Ready, the indicator will keep on, and it will flash when entering the learning.

RJ11 (RS485) Control:

Using the MODBUS protocol

The default is master, you can use app be set to slave

When other slaves are connected, they will be automatically detected and include the device



Troubleshooting

Symptom	Cause of Failure	Recommendation
The switch does not work and the LED is off	<ol style="list-style-type: none"> The Switch is not plugged into the electrical outlet properly The Switch break down 	<ol style="list-style-type: none"> Check power connections Don't open up the Switch and send it for repair.
The LED illuminates, but cannot turn ON or OFF the switch of the load attached	<ol style="list-style-type: none"> Check if the load plugged into the Switch has its own ON/OFF switch Not carry out association Same frequency interference 	<ol style="list-style-type: none"> Set the ON/OFF switch of the load attached to ON Carry out association Wait for a while to re-try
LED keep flashing, but cannot control	Overload occurs	Remove the load attached or check max. load cannot exceed 16.0A

Situation	Root cause	Solution
No LED indicator	1. No main power	Please check the LN power line and power outlet
	2. PAN27 is broken	Please return to the vender.
LED is normal, but the device is no action	Please make sure the device has own switch	Please turn the device to On.

Specification

Operating Voltage	100-240VAC 50/60Hz 16A
Rated Voltage	AC100-240V 50Hz
Output Current	Max.16A Relay Dongle: 5A (model: ME001) Dimmer Dongle: 0.7A (model: ME002) 8 independent relay or dimmer outputs
Maximum DC output	DC12V*8
Maximum AC output	16A
Range	Minimum 40 m in door and 100m outdoor; line of sight
Operating Temperature	0°C ~ 40°C (85% humidity)
Storage Temperature	-20 C ~ 60°C
interface	RJ11 (4P2C) for RS485 interface RJ45 10/100 base-T
USB port	Z-wave 500 series Dongle (operational) ZigBee Dongle (operational)
Location	Indoor use only
Frequency Range	IEEE 802.11 b/g/n 2412-2472MHz (EU), 2412-2462MHz (USA)
RF power	+17dBm
Dimension	210 (L) x 90(W) x 78 (H) mm
Patent pending	

** Specifications are subject to change and improvement without notice.

FCC ID: RHPAN27



www.philio-tech.com

Philio Technology Corporation

8F., No.653-2, Zhongzheng Rd., Xinzhuang Dist., New Taipei City 24257, Taiwan



DANGER

Danger of electrocution!

All works on the device may be performed only by a qualified and licensed electrician. Observe national regulations.

Any works introducing changes into the configuration must be always performed with disconnected voltage.

Choosing a Suitable Location

1. Do not locate the Module facing direct sunlight, humid or dusty place.
2. The suitable ambient temperature for the Module is 0°C~40°C.
3. Do not locate the Module where exists combustible substances or any source of heat, e.g. fires, radiators, boiler etc.
4. After putting it into use, the body of Module will become a little bit hot of which phenomenon is normal.

Warning:

1. This device must be installed by qualified personnel;
2. This device must not be installed directly outdoors;
3. Installation consists of mounting the device, connecting to an IP network, connecting the relays, providing power and configuring via a web browser.

Box mounting

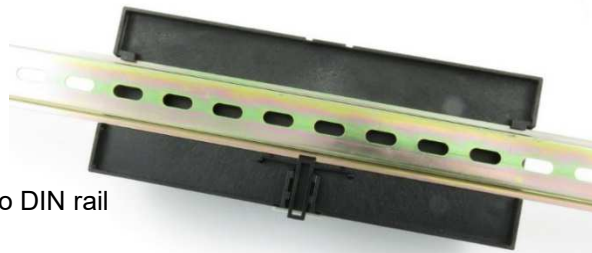

Mounting the device to DIN rail

Smart Home DIN rail box can be mounted to a standard (210mm x 90mm x 78mm) DIN rail. Attach the module to the DIN rail by hooking the hook on the back of the enclosure to the DIN rail and then snap the bottom hook into place.

Disposal



1.

This marking indicates that this product should not be disposed with other household wastes throughout the EU. To prevent possible harm to the environment or human health from uncontrolled waste disposal, recycle it responsibly to promote the sustainable reuse of material resources. To return your used device, please use the return and collection systems or contact the retailer where the product was purchased. They can take this product for environmental safe recycling

FCC Interference Statement

This equipment has been tested and found to comply with the limits for a Class B digital device, pursuant to Part 15 of the FCC Rules.

These limits are designed to provide reasonable protection against harmful interference in a residential installation.

This equipment generates, uses and can radiate radio frequency energy and, if not installed and used in accordance with the instructions, may cause harmful interference to radio communications.

However, there is no guarantee that interference will not occur in a particular installation.

If this equipment does cause harmful interference to radio or television reception, which can be determined by turning the equipment off and on, the user is encouraged to try to correct the interference by one of the following measures:

- Reorient or relocate the receiving antenna.
- Increase the separation between the equipment and receiver.
- Connect the equipment into an outlet on a circuit different from that to which the receiver is connected.
- Consult the dealer or an experienced radio/TV technician for help.

This device complies with Part 15 of the FCC Rules. Operation is subject to the following two conditions:

- (1) This device may not cause harmful interference, and
- (2) This device must accept any interference received, including interference that may cause undesired operation.

FCC Caution: Any changes or modifications not expressly approved by the party responsible for compliance could void the user's authority to operate this equipment.

RF exposure warning

This equipment must be installed and operated in accordance with provided instructions and the antenna(s) used for this transmitter must be installed to provide a separation distance of at least 20 cm from all persons and must not be co-located or operating in conjunction with any other antenna or transmitter. End-users and installers must be provide with antenna installation instructions and transmitter operating conditions for satisfying RF exposure compliance.