

Register your product and get support at
www.philips.com/welcome

CEM250/55



EN User manual 3

Contents

| | |
|--------------------------------------|----|
| 1 Important | 4 |
| Safety | 4 |
| Notice | 4 |
| 2 Your Car Audio System | 6 |
| Introduction | 6 |
| What's in the box | 6 |
| Overview of the main unit | 7 |
| Overview of the remote control | 8 |
| 3 Get started | 10 |
| Install the car audio | 10 |
| Install remote control battery | 15 |
| Turn on | 15 |
| Set clock | 15 |
| 4 Listen to radio | 16 |
| Tune to a radio station | 16 |
| Store radio stations in memory | 16 |
| Tune to a preset station | 16 |
| 5 Use bluetooth devices | 17 |
| Pairing bluetooth devices | 17 |
| Play audio files | 17 |
| Voice dialing | 17 |
| Make a call | 17 |
| Call waiting | 17 |
| Call transfer | 17 |
| Terminate call | 17 |
| 6 Play audio files | 18 |
| Play a disc | 18 |
| Play from USB/SD/MMC device | 18 |
| Control play | 19 |
| Search for an MP3/WMA track | 19 |
| View play information | 19 |
| Random play | 19 |
| Repeat play | 20 |
| Intro play | 20 |
| Select shock-protect setting | 20 |
| 7 Adjust sound | 21 |
| Adjust volume | 21 |
| Turn Dynamic Bass Boost (DBB) on/off | 21 |
| Select preset equalizer | 21 |
| Other sound settings | 21 |
| 8 Adjust system settings | 22 |
| Set PIN code | 22 |
| Set bluetooth connection | 22 |
| Select blackout setting | 22 |
| Turn demo mode on/off | 22 |
| Change button backlight color | 22 |
| Select start volume | 22 |
| Turn beep sound on/off | 23 |
| Turn display scroll on/off | 23 |
| Reset | 23 |
| 9 Additional information | 24 |
| Detach the front panel | 24 |
| Replace fuse | 24 |
| Remove the unit | 24 |
| Connect external sound source | 24 |
| 10 Product information | 25 |
| 11 Troubleshooting | 27 |
| 12 Glossary | 28 |

1 Important

Safety

- Read and understand all instructions before you use your unit. If damage is caused by failure to follow instructions, the warranty does not apply.
- This unit is designed for negative ground (earth) 12V DC operation only.
- To ensure safe driving, adjust the volume to a safe and comfortable level.
- Improper fuses can cause damage or fire. When you need to change the fuse, consult a professional.
- Use only the supplied mounting hardware for a safe and secure installation.
- To avoid short circuit, do not expose the unit, remote control or remote control batteries to rain or water.
- Never insert objects into the ventilation slots or other openings on the unit.
- Clean the unit and frame with a soft, damp cloth. Never use substances such as alcohol, chemicals or household cleaners on the unit.
- Never place any objects other than discs into the unit.
- Never use solvents such as benzene, thinner, cleaners available commercially, or anti-static sprays intended for discs.
- Visible and invisible laser radiation when open. Avoid exposure to beam.
- Risk of damage to the unit screen! Never touch, push, rub or strike the screen with any object.

! Caution

- Use of controls or adjustments or performance of procedures other than herein may result in hazardous radiation exposure or other unsafe operation.

Notice

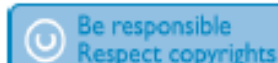

The making of unauthorized copies of copy-protected material, including computer programs, files, broadcasts and sound recordings, may be an infringement of copyrights and constitute a criminal offence. This equipment should not be used for such purposes.

This unit includes these labels:



Class II equipment symbol



This symbol indicates that the unit has a double insulation system.

Recycling

Your product is designed and manufactured with high quality materials and components, which can be recycled and reused.

When you see the crossed-out wheel bin symbol attached to a product, it means the product is covered by the European Directive 2002/96/EC:



Never dispose of your product with other household waste. Please inform yourself about the local rules on the separate collection of electrical and electronic products. The correct disposal of your old product helps prevent potentially negative consequences on the environment and human health.

Your product contains batteries covered by the European Directive 2006/66/EC, which cannot be disposed of with normal household waste. Please inform yourself about the local rules on separate collection of batteries. The correct disposal of batteries helps prevent potentially negative consequences on the environment and human health.



This product complies with the radio interference requirements of the European Community.

This product complies with the requirements of the following directives and guidelines: <RadioInterferenceDirectives>

Environmental information

All unnecessary packaging has been omitted. We have tried to make the packaging easy to separate into three materials: cardboard (box), polystyrene foam (buffer) and polyethylene (bags, protective foam sheet.)

Your system consists of materials which can be recycled and reused if disassembled by a specialized company. Please observe the local regulations regarding the disposal of packaging materials, exhausted batteries and old equipment.

Any changes or modifications made to this device that are not expressly approved by

Philips Consumer Lifestyle may void the user's authority to operate the equipment.

2008 © Koninklijke Philips Electronics N.V. All rights reserved.

Specifications are subject to change without notice. Trademarks are the property of Koninklijke Philips Electronics N.V. or their respective owners. Philips reserves the right to change products at any time without being obliged to adjust earlier supplies accordingly.

CAUTION:

Changes or modification not expressly approved by the party responsible for compliance could void the user's authority to operate the equipment.

a. For Class B digital device or peripheral:

NOTE: This equipment has been tested and found to comply with the limits for a Class B digital device, pursuant to Part 15 of the FCC Rules. These limits are designed to provide reasonable protection against harmful interference in a residential installation. This equipment generates, uses and can radiate radio frequency energy and, if not installed and used in accordance with the instructions, may cause harmful interference to radio communications. However, there is no guarantee that interference will not occur in a particular installation. If this equipment does cause harmful interference to radio or television reception, which can be determined by turning the equipment off and on, the user is encouraged to try to correct the interference by one or more of the following measures:

- Reorient or relocate the receiving antenna.
- Increase the separation between the equipment and receiver.
- Connect the equipment into an outlet on a circuit different from that to which the receiver is connected.
- Consult the dealer or an experienced radio/TV technician for help.

2 Your Car Audio System

Congratulations on your purchase, and welcome to Philips! To fully benefit from the support that Philips offers, register your product at www.Philips.com/welcome.

Introduction

With the in-car audio system, you can enjoy your drive while you listen to:

- FM or AM (MW) radio
- Audio from CD or MP3 disc
- Audio from your mobile phone
- Audio from a USB drive
- Audio from a SD/MMC card
- Audio from external devices

Besides, you can dial number, answer and hang up a call on the audio system.

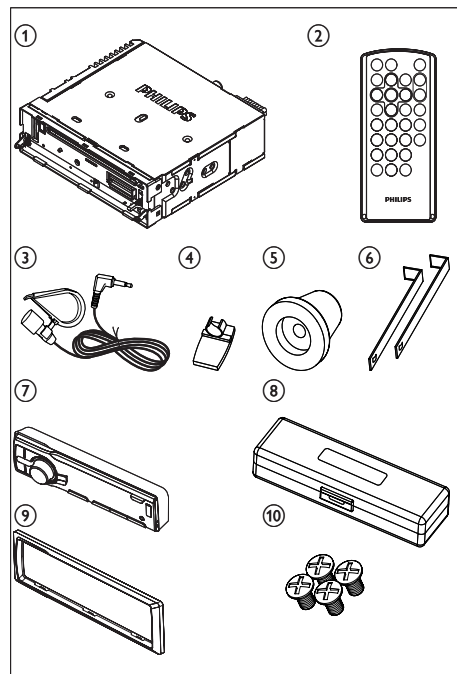

What's in the box

Check and identify the contents of your package:

- 1 Car audio system
- 2 Remote control
- 3 Microphone
- 4 Microphone hold
- 5 Rubber cushion
- 6 Disassembly tool (2 pieces)
- 7 Front panel
- 8 Carrying case for front panel
- 9 Trim plate
- 10 Screw (4 pieces)

Overview of the main unit

4 **⓪/MUTE**

- Turn the unit on or off.

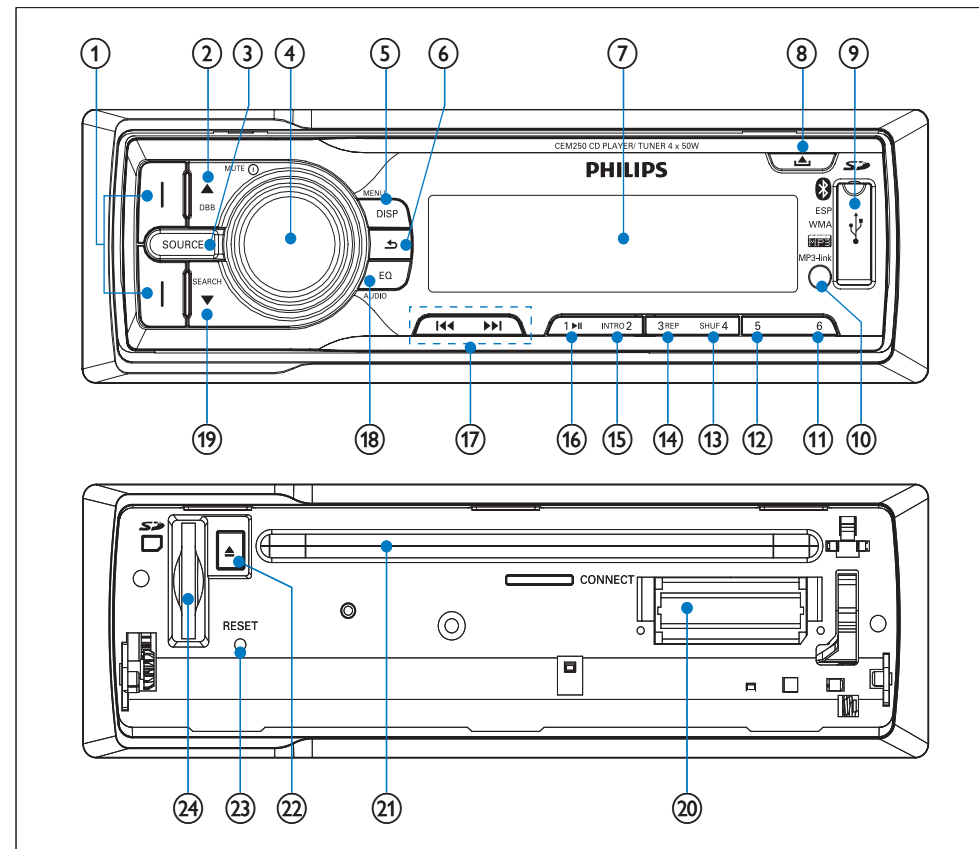

1 **| (green/red)**

- Answer phone (green)
- Dial number (green)
- View call log (green)
- Terminate call (red)

2 **▲/ DBB**

- Select tuner band.
- Select MP3/WMA folder.
- Scroll up menu.
- Turn on or off Dynamic Bass Boost (DBB) sound.

3 **SOURCE**

- Select audio source.

- Adjust volume.
- Confirm selection.
- Enter characters for search.
- Dial phone number.
- Mute or unmute the volume.

5 **MENU / DISP**

- Display radio frequency, clock and radio program type (if available).
- Display track, elapsed time, artist, album, title, folder, file and clock.
- Access system menu.

6 **↶**

- Return to previous menu.
- Stop search.

- Disable screen blackout.
- Display panel**
 - ▲**
 - Unlock the panel
 - USB socket**
 - External equipment socket**
 - 6**
 - Select preset station no. 6
 - 5**
 - Select preset station no. 5
 - SHUF, 4**
 - Set shuffle play mode.
 - Select preset station no. 4
 - 3, REP**
 - Set repeat play mode.
 - Select preset station no. 3
 - INTRO, 2**
 - Turn intro play on or off.
 - Select preset station no. 2
 - 1, ►||**
 - Start play
 - Pause or resume play.
 - Select preset station no. 1
 - ◀◀/▶▶**
 - Tune for radio station
 - Skip/search for MP3/WMA track.
 - EQ/Audio**
 - Select equalizer (EQ) setting.
 - Access audio setting menu.
 - ▼/SEARCH**
 - Select tuner band.
 - Store radio stations automatically.
 - Scroll up or down menu.
 - Select MP3/WMA folder.
 - Search a track or folder:
 - Panel power connection**
 - Disc slot**
 - ▲**
 - Take disc out.

- RESET**
 - Restore default settings
- SD/MMC card slot**

Overview of the remote control

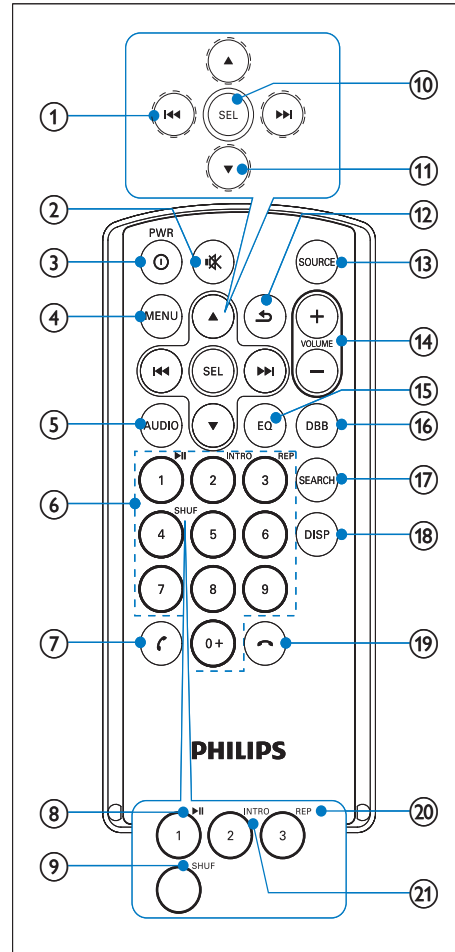

- ◀◀/▶▶**
 - Tune for radio station
 - Skip/search for a track.
- ⏻**

- Mute or restore volume.
- ⏻PWR**
 - Turn the unit on or off.
 - MENU**
 - Access system menu.
 - AUDIO**
 - Access audio setting menu.
 - 5/6/7/8/9/0+**
 - Select track or preset radio station.
 - Enter phone number.
 - ☎**
 - Answer phone.
 - Dial number.
 - 1 ►||**
 - Start play from the beginning of the first track.
 - Pause or resume play.
 - Select preset station no. 1.
 - Enter phone number.
 - SHUF, 4**
 - Set shuffle play mode.
 - Select preset station no. 4.
 - Enter phone number.
 - SEL**
 - Confirm selection.
 - ▲/▼**
 - Tune for radio station
 - Skip/search for MP3/WMA track.
 - ↶**
 - Return to previous menu.
 - Disable screen blackout.
 - SOURCE**
 - Select audio source
 - VOLUME +/-**
 - Adjust volume.
 - EQ**
 - Select EQ setting.
 - DBB**
 - Turn on or off Dynamic Bass Boost (DBB) sound.
 - SEARCH**
 - Set radio station memory automatically.
 - Search a track or folder.
 - DISP**
 - Display radio frequency, clock and radio program type (if available).
 - Display MP3/WMA elapsed time, last listened radio frequency, and clock.
 - ☎**
 - Terminate call
 - 3, REP**
 - Set repeat play mode.
 - Select preset station no. 3
 - Enter phone number.
 - INTRO, 2**
 - Turn intro play on or off.
 - Select preset station no. 2
 - Enter phone number.

3 Get started

! Caution

- Use the controls only as stated in this user manual.

Always follow the instructions in this chapter in sequence.

If you contact Philips, you will be asked for the model and serial number of your unit. The model number and serial number are on the bottom of your unit. Write the numbers here:
 Model No. _____
 Serial No. _____

Install the car audio

⚠ These instructions are for a typical installation. However, if your car has different requirements, make the corresponding adjustment. If you have any questions regarding installation kits, consult your Philips car audio dealer.

! Caution

- This unit is designed for negative ground (earth) 12V DC operation only.
- Always install this unit in the car dashboard. Other locations can be dangerous as the rear of the unit heats up during use.
- To avoid short-circuit: before you connect, ensure that the ignition is off.
- Ensure that you connect the yellow and red power supply leads after all other leads are connected.
- Ensure that all loose leads are insulated with electrical tape.
- Ensure that the leads do not get caught under screws or in parts that will move (e.g. seat rail).
- Ensure that all ground (earth) leads are run to a common ground (earth) point.
- Use only the supplied mounting hardware for a safe and secure installation.
- Improper fuses can cause damage or fire. When you need to change the fuse, consult a professional.

- When you connect other devices to this unit, ensure that the rating of the car circuit is higher than the total fuse value of all the connected devices.

Notes on speaker connection

- Never connect speaker wires to the metal body or chassis of the car.
- Never connect speaker wires with stripes to one another.

Overview of parts

These are the supplied parts needed to connect and install this unit.

- 1 In-car audio system
- 2 Sleeve
- 3 Front panel
- 4 Trim plate
- 5 Rubber cushion
- 6 Disassembly tools
- 7 Screws 4 pieces

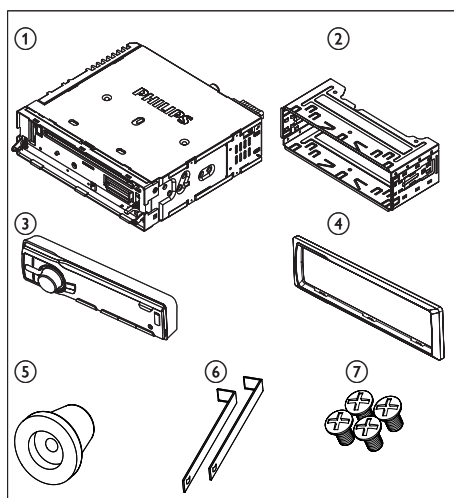

Note on the power supply lead (yellow)

Connect wires: for cars with ISO connectors

! Caution

- Ensure that all loose leads are insulated with electrical tape.

- 1 Pull out the ISO connectors from car dashboard and connect them to the bigger end of the supplied standard connector.

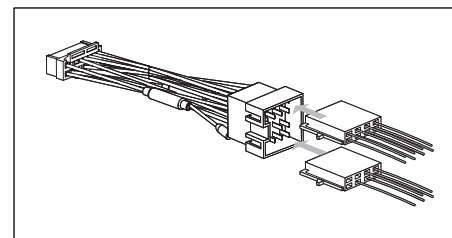

- 2 Connect the other end of the supplied standard connector to the unit.

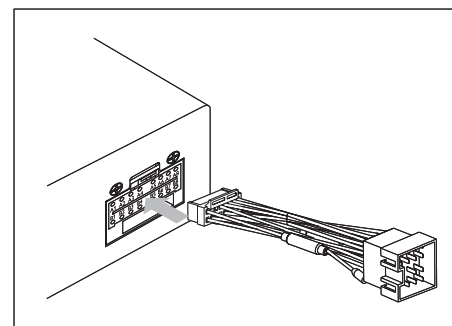

- 3 Connect the antenna and amplifier as illustrated, if applicable.

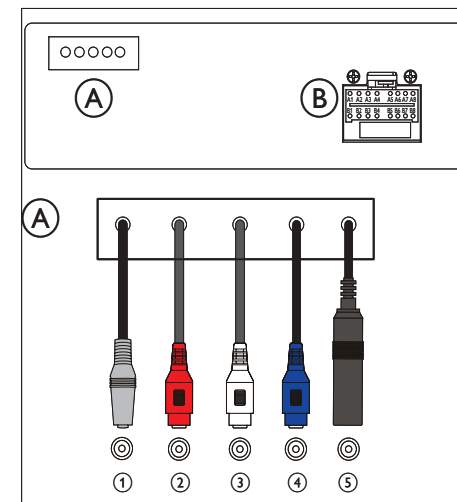

| | Connector | Connect to |
|---|-----------------|--------------------|
| 1 | MIC | Microphone |
| 2 | REAR LINE OUT R | Rear right speaker |
| 3 | REAR LINE OUT L | Rear left speaker |
| 4 | SUB OUT | Subwoofer |
| 5 | ANTENNA | Antenna |

Connect wires: for cars without ISO connectors

! Caution

- Be sure to connect the black ground (earth) lead first.

- 1 Connect the antenna and amplifier as illustrated, if applicable.

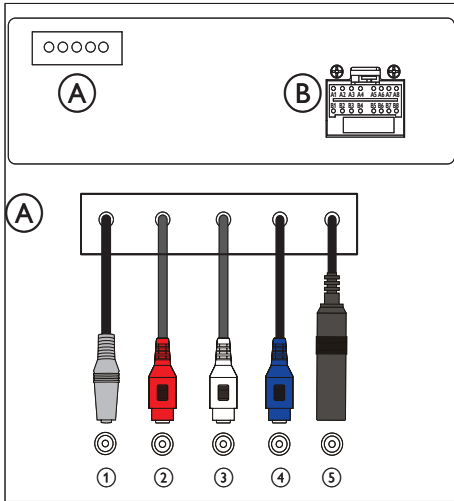

| | Connector | Connect to |
|---|-----------------|--------------------|
| 1 | MIC | Microphone |
| 2 | REAR LINE OUT R | Rear right speaker |
| 3 | REAR LINE OUT L | Rear left speaker |
| 4 | SUB OUT | Subwoofer |
| 5 | ANTENNA | Antenna |

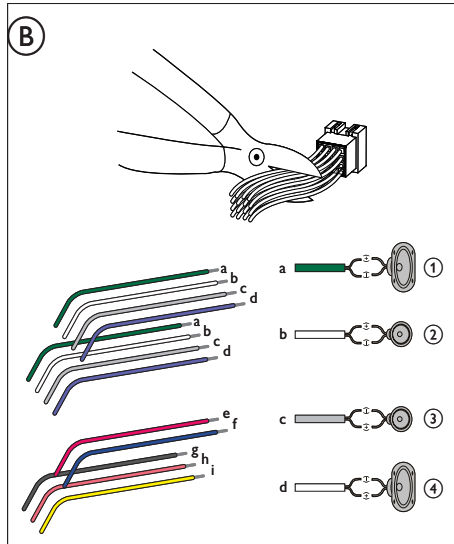

| | | |
|---|--------------------|-----------------------|
| 1 | Green/black strip | Left speaker (Rear) |
| 2 | White/black strip | Left speaker (Front) |
| 3 | Gray/black strip | Right speaker (Front) |
| 4 | Purple/black strip | Right speaker (Rear) |

| | | |
|---|------------------|--|
| e | RED | Ignition key +12V DC when ON/ACC |
| f | BLUE | Motor/electric antenna relay control lead/ Amplifier relay control lead |
| g | BLACK | Ground |
| h | ORANGE/ WHITE | Illumination switch |
| i | YELLOW | To the +12V car battery which is energized at all times |

- Cut off the bigger end of the supplied standard connector.
- Check the car's wiring carefully and connect them to the supplied standard connector.

- Connect the supplied standard connector to the unit.

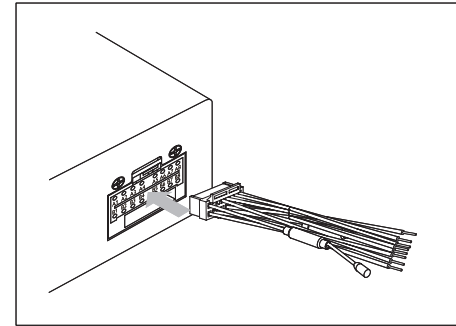

Attach the front panel

- Insert the right side of the panel in the chassis until it is correctly engaged.

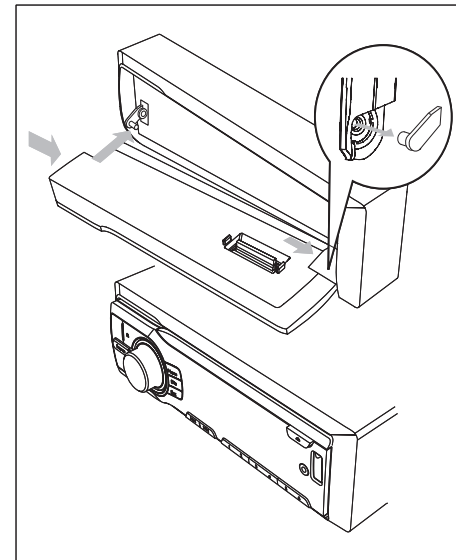

- Press the left side of the panel and point the left hole at the left pillar.
- Release the panel to engage the left side.
- Attach the trim plate.

Mount in the dashboard

- If the car does not have an on-board drive or navigation computer, disconnect the negative terminal of the car battery.
 - If you disconnect the car battery in a car that has an on-board drive or navigation computer, the computer may lose its memory.
 - If the car battery is not disconnected, to avoid short-circuit, ensure that bare wires do not touch each other.
- Remove the mounting sleeve with the supplied disassembly tools.

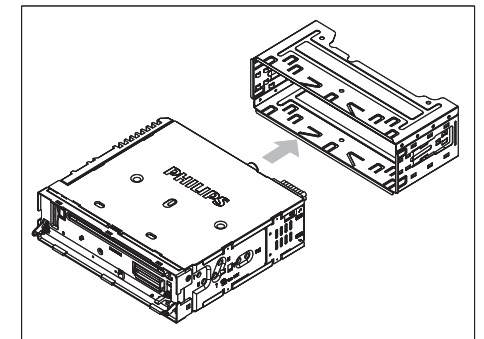

- Ensure that car dashboard opening is within these measurements:

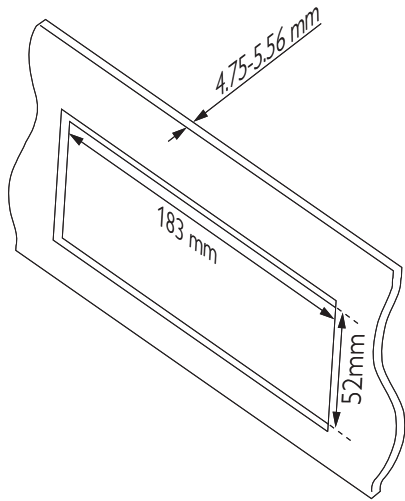

- 4 Install the sleeve into the dashboard and bend the tabs outward to fix the sleeve.

Note

- Skip this step if the unit is not fixed by sleeve but supplied screws.

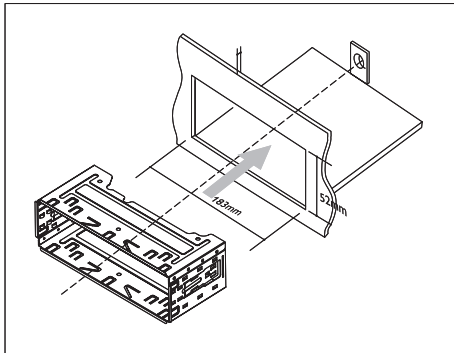

- 5 Remove the two screws on the top of the unit.

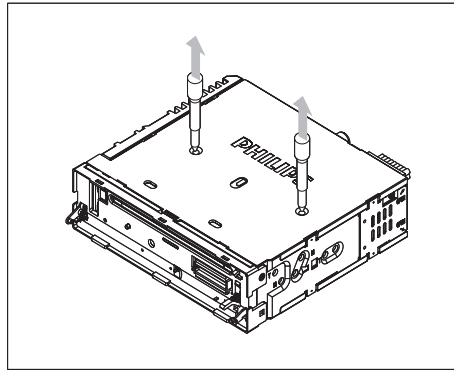

- 6 Place the supplied rubber cushion over the end of the mounting bolt.

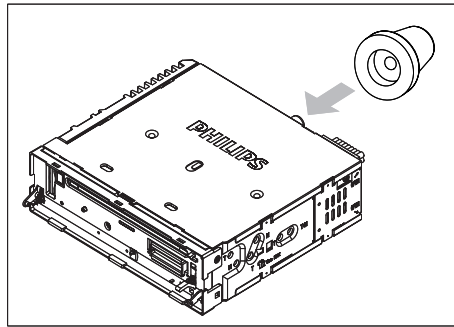

- 7 Slide the unit into the dashboard until you hear a click sound.
8 Reconnect the negative terminal of the car battery.

Install remote control battery

! Caution

- Risk of explosion! Keep batteries away from heat, sunshine or fire. Never discard batteries in fire.
- Risk of decreased battery life! Never mix different brands or types of batteries.
- Risk of product damage! When the remote control is not used for long periods, remove the batteries.
- Perchlorate Material - special handling may apply. See www.dtsc.ca.gov/hazardouswaste/perchlorate.

For first-time use:

- 1 Remove the protective tab to activate the remote control battery.

To replace the remote control battery:

- 1 Open the battery compartment.
2 Insert 1 CR2025 batteries with correct polarity (+/-) as indicated.
Close the battery compartment.

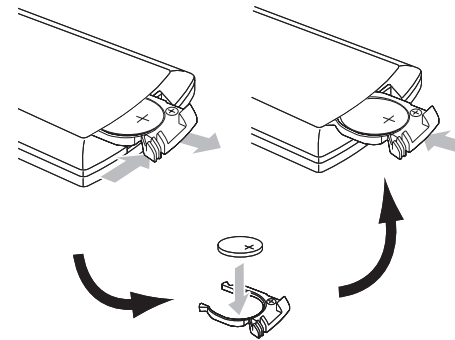

Turn on

- 1 Press \odot to turn on the unit.
- To turn off the unit, press \odot for 3 seconds.

Set clock

- 1 Press **MENU/DISP** for 3 seconds.
- 2 Press \blacktriangle or \blacktriangledown repeatedly until the currently time is displayed.
- 3 Turn \odot clockwise to set hour.
- 4 Turn \odot anti-clockwise to set minute.
- 5 Press \odot to confirm.

View clock

- 1 Press **MENU/DISP** repeatedly until the clock is displayed.

4 Listen to radio

Tune to a radio station

- 1 Press **SOURCE** repeatedly to select Tuner.
- 2 Press ▲ or ▼ to select band: **[FM1]**, **[FM2]**, **[FM3]**, **[AM1]**, or **[AM2]**.
- 3 Press **◀◀** or **▶▶** to tune to a radio station manually.
 - ↳ The radio station is broadcast.
 - ↳ To search for a radio station automatically, press **◀◀** or **▶▶** for 3 seconds.

Select tuner sensitivity

You can adjust the tuner sensitivity if you want to receive more radio stations or only stations with strong signal.

- 1 Press **MENU/DISP** for over 2 seconds.
- 2 Press ▲ or ▼ repeatedly until **[LOCAL]** or **[DX]** is displayed.
 - **[LOCAL]** (local): Only stations with strong signal can be broadcast.
 - **[DX]** (distance): Stations with strong and weak signals can be broadcast.
- 4 Press **⊕** to confirm the selection.

Select stereo/mono broadcasting

For stations with weak signals: to improve the reception, change to monoaural sound.

- 1 Press **MENU/DISP** for 3 seconds.
- 2 Press ▲ or ▼ repeatedly until **[STEREO]** or **[MONO]** is displayed.
- 3 Turn **⊕** to select a setting:
 - **[STEREO]**: stereo broadcast.
 - **[MONO]**: mono broadcast.
- 4 Press **⊕** to confirm the selection.

Store radio stations in memory

You can store up to 6 stations in each band.

Store stations automatically

- 1 Press **SEARCH** for 3 seconds.
 - ↳ The six strongest stations of the selected band are saved in preset channels 1-6 automatically.

Store stations manually

- 1 Tune to a station that you want to store. (see 'Tune to a radio station' on page 16)
- 2 Press one of the numbered buttons **1** to **6** for 3 seconds.
 - ↳ The station is saved in the selected channel.

Tune to a preset station

- 1 Press ▲ or ▼ to select band.
- 2 Press the number button **1** to **6** to select the preset station.

5 Use bluetooth devices

With this car audio system, you can listen to audio files from a player or make a call if bluetooth connection is available on your phone or player.

Pairing bluetooth devices

You can pair your bluetooth device with the unit as follows:

- 1 Turn on bluetooth function on the device.
- 2 Setup bluetooth function on your device.
- 3 Select "CEM250" in the pairing list.
- 4 Enter default password "0000".
 - ↳ "[PAIR OK]" is displayed on the panel if pairing succeeds.
 - ↳ Otherwise, "[PAIR ERR]" is displayed.
 - ↳ "[CONNECT]" is displayed when connection is established.

Play audio files

You can listen to audio from a bluetooth device and control playback with the unit.

- 1 Press **SOURCE** repeatedly to select **[BT MUSIC]**.
 - To play, press **1, ▶||**.
 - To pause, press **1, ▶|||** again.

Voice dialing

You can dial a number by voice if your mobile phone supports voice dialing.

- 1 Press **☎** for 3 seconds.
 - ↳ **[VOIC DIAL]** is displayed.

- 2 Speak a name stored in contact list stored in the phone.
 - ↳ The unit repeats the number and calls out.
 - ↳ **[NO MATCH]** is displayed if the unit does not recognize a number.

Make a call

- 1 Press **☎**.
- 2 Press 0-9 to enter phone number:
 - Press **◀◀/▶▶** to change a number.
 - Press **↶** to reset entered numbers.
- 3 Press **☎** to dial.

Call waiting

If there is another incoming call during call, **[CALL WAITING]** flashes on the display panel.

- 1 Press **☎** to terminate the present call.
 - ↳ The other call is automatically answered.
 - ↳ The first call is terminated.

Call transfer

You can transfer voice from loudspeaker to mobile phones during call.

- 1 Press **☎**.
 - ↳ **[TRANSFER]** is displayed.

Terminate call

- ① Press **↶** to terminate call.

6 Play audio files

Note

- Ensure that the disc or device contains playable files.

Play a disc

Note

- You cannot play CDs encoded with copyright protection technologies.

You can play commercially available audio CDs and these discs:

- CD-Recordables (CD-R)
- CD-Re-writables (CD-RW)
- MP3 CDs
- WMA CDs

- 1 Press **▲** on the front panel to release the panel.
- 2 Insert a CD with the printed side facing up.
- 3 Close the panel.
- 4 Press **1**, **▶||** to start play.
 - To pause CD play, press **▶||**.
 - To resume CD play, press **▶||** again.

Remove the CD

To take out the CD,

- 1 Press **▲**.
- 2 Press **▲** beside the disc slot.

Play from USB/SD/MMC device

Note

- Ensure that the USB or SD/MMC device contains playable music.

Insert the USB device

- 1 Open the cover marked **USB** on the front panel.

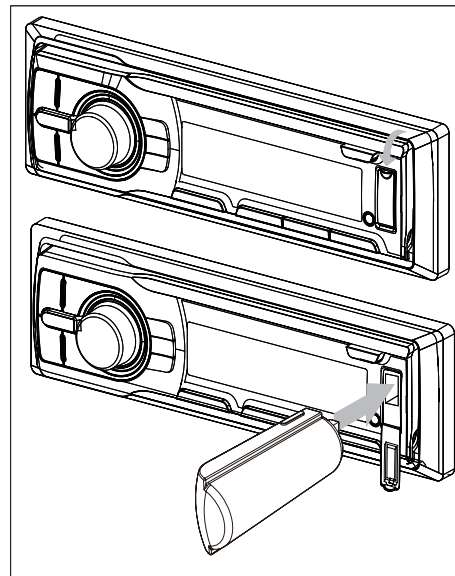

- 2 Insert the USB device into the USB socket.
 - ↳ The unit starts playing from the USB device automatically.

Remove the USB device

- 1 Press and hold **⏻** to turn off the unit.
- 2 Remove the USB device.

Insert SD/MMC card

- 1 Press **▲** to release the panel.
- 2 Insert the SD or MMC card into the card slot.
 - ↳ The unit starts playing from the SD/MMC card automatically.

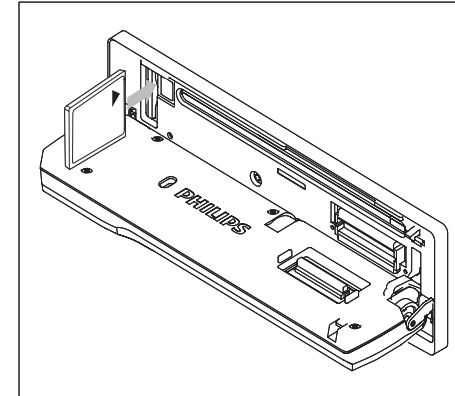

Remove the SD/MMC card

- 1 Press and hold **⏻** to turn off the unit.
- 2 Press the card until you hear a click sound.
 - ↳ The card is now disengaged.
- 3 Remove the SD or MMC card.

Control play

- To select a folder, press **▲** or **▼**.
- To skip to the previous/next track, press **◀◀** or **▶▶**.
- To search backward/forward rapidly within the current track, press **◀◀** or **▶▶** for 3 seconds.
- To pause, press **▶||**.
- To resume play, press **▶||** again.

Search for an MP3/WMA track

- 1 Press **SEARCH** for 3 seconds.
 - ↳ Search menu is displayed.
 - ↳ **[FILE]**: search by track name.
 - ↳ **[FOLDER]**: search by folder sequence.
- 2 Turn **⊙** to select **[FILE]** and then press **⊙** to confirm.
- 3 Turn **⊙** to enter a character and then press **⊙**.
- 4 Repeat steps 3 until the search term is complete.
- 5 Press **⊙** for 3 seconds to start search.
 - ↳ When search is finished, a list of matching tracks are displayed.
- 6 Turn **⊙** to skip over the list.
- 7 Press **⊙** to select a track.

View play information

- 1 During play USB/SD/MMC device, press **MENU/DISP** repeatedly to view:
 - Track number and elapsed play time
 - Artist
 - Album
 - Title
 - Folder
 - File
 - Clock

Random play

You can play the tracks in random order:

- 1 During play, press **SHUF, 4** to select:
 - **[RDM FOLD]**: start random play in the current folder.
 - **[RDM ALL]**: start random play for all tracks.
 - **[RDM OFF]**: cancel random play.

Repeat play

During play, press **3, REP** repeatedly to select:

- **[REP 1]** (repeat one track): play the current track repeatedly.
- **[REP FOLD]** (repeat one folder): play all tracks in the current folder repeatedly.
- **[REP ALL]** (repeat all tracks): play all tracks repeatedly.
- **[REP OFF]** (repeat off): cancel repeat play.

Intro play

You can play the first 10 seconds of each track.

- 1 During play, press **INTRO, 2** to select:
 - **[INT ON]**: After the first 10 seconds of each track have been played, play stops.
 - **[INT OFF]**: Cancel intro play and start normal play.

Select shock-protect setting

You can select the shock protection setting, depending on the stability of your car and the condition of the road.

- 1 Press **MENU/DISP** for 3 seconds.
- 2 Press **▲** or **▼** repeatedly until **[ESP]** is displayed.
- 3 Turn **⊖** to select a setting:
 - **[ESP 12]**: select this when the road is smooth and there are few bumps.
 - **[ESP 45]** select this when the road is bumpy and unstable.
- 4 Press **⊖** to confirm the selection.

7 Adjust sound

Adjust volume

- 1 Turn **⊖** clockwise/anticlockwise to increase/decrease volume.

Turn Dynamic Bass Boost (DBB) on/off

- 1 Press **DBB** for 3 seconds, the current setting is displayed:
 - ↳ **[DBB ON]**: The Dynamic Bass Boost (DBB) function is on.
 - ↳ **[DBB OFF]**: The DBB function is off.
- 2 Press **DBB** again for 3 seconds to change the DBB setting.

Select preset equalizer

- 1 Press **EQ/Audio**.
 - ↳ The current Equalizer setting is displayed.
- 2 Press **EQ/Audio** again repeatedly to select a preset EQ:
 - **[USER]** (user)
 - **[FLAT]** (flat)
 - **[POP]** (pop)
 - **[TECHNO]** (techno)
 - **[ROCK]** (rock)
 - **[CLASSIC]** (classic)
 - **[JAZZ]** (jazz)
 - **[OPTIMAL]** (optimal)

Other sound settings

You can also edit user preset EQ.

- 1 Press **EQ/Audio** for 3 seconds.

- 2 Press **▲** or **▼** repeatedly to select the item to be adjusted:
 - **[BAS]** (bass) range: -7 to +7.
 - **[MID]** (bass) range: -7 to +7.
 - **[TRE]** (treble) range: -7 to +7.
 - **[BAL]** (balance) range: 12L to 12R. (L = left speaker; R = right speaker)
 - **[FAD]** (fader) range: 12R to 12F. (R = rear speaker; F = front speaker)
 - **[LPF]** (low pass filter) range: 60, 80, 100, 200.
 - **[MPF]** (mid pass filter) range: 500, 1K, 1.5K, 2.5K.
 - **[HPF]** (high pass filter) range: 10K, 12.5K, 15K, 17.5K.
 - **[SW ON]/[SW OFF]** (subwoofer volume on or off)
 - **[SW VOL]** (subwoofer volume) range: 0 to 20.
- 3 Turn **⊖** to select a value.
- 4 Press **⊖** to confirm.

8 Adjust system settings

Set PIN code

You can set a password for bluetooth connection.

- 1 Press **MENU/DISP** for 3 seconds.
- 2 Press **▲** or **▼** repeatedly to until **[PIN CODE]** is displayed.
- 3 Press **⊙** to confirm selection.
- 4 Turn **⊙** and then press **⊙** to enter a digit.
- 5 Repeat step 4 to enter other three digits.

Set bluetooth connection

You can set whether the set connects to last bluetooth device automatically.

- 1 Press **MENU/DISP** for 3 seconds.
- 2 Press **▲** or **▼** repeatedly to until **[AUTO ON]** or **[AUTO OFF]** is displayed.
 - **[AUTO ON]**: The unit connects to last bluetooth device automatically.
 - **[AUTO OFF]**: does not connect automatically
- 3 Press **⊙** to confirm selection.

Select blackout setting

You can set the screen to turn off automatically after the unit is idle for 10 or 20 seconds.

- 1 Press **MENU/DISP** for 3 seconds.
- 2 Turn **⊙** to select a setting:
 - **[BKO 10 S]**: Turn off the screen automatically 10 seconds after last operation.

- **[BKO 20 S]**: Turn off the screen automatically 20 seconds after last operation.
- **[BKO OFF]**: Never turn off the screen.

- 3 Press **⊙** to confirm.

Turn demo mode on/off

When demo mode is on, when the unit is idle for more than 2 minutes, all functions are displayed.

- 1 Press **MENU/DISP** for 3 seconds.
- 2 Press **▲** or **▼** repeatedly to until **[DEMO]** is displayed.
 - ↳ The screen shows current Demo mode setting.
- 3 Turn **⊙** to select a setting:
 - **[DEMO ON]**: Turn on the demo mode.
 - **[DEMO OFF]**: Turn off the demo mode.
- 4 Press **⊙** to confirm.

Change button backlight color

You can change button backlight color from blue to red or vice versa.

- 1 Press **MENU/DISP** for 3 seconds.
- 2 Press **▲** or **▼** repeatedly to until **[KEY BLUE]** or **[KEY RED]** is displayed.
- 3 Turn **⊙** to select a setting:
 - **[KEY BLUE]**: Backlight turns blue.
 - **[KEY RED]**: Backlight turns red.

Select start volume

Each time you turn on the unit, it can play at the last listened volume or at the preset volume.

- 1 Press **MENU/DISP** for 3 seconds.
- 2 Press **▲** or **▼** repeatedly to until **[V - LAST]** or **[V - AD]** is displayed.
- 3 Turn **⊙** to select a setting:
 - **[V - LAST]**: Each time you turn on the unit, the volume remains from its previous use.
 - **[V - AD]**: Each time you turn on the unit, the volume is at the preset level.
- 4 Press **⊙** to confirm.

Store preset volume

You can turn on the unit at a preset volume.

- 1 Select
- 2 Press **MENU/DISP** for 3 seconds.
- 3 Press **▲** or **▼** repeatedly to until **[A-VOL]** is displayed.
- 4 Turn **⊙** to select a value: 0 - 47.
- 5 Press **⊙** to confirm.

Turn beep sound on/off

Each time you press a button, the unit beeps. You can turn off/on this beep sound.

- 1 Press **MENU/DISP** for 3 seconds.
- 2 Press **▲** or **▼** repeatedly to until **[BEEP ON]** or **[BEEP OFF]** is displayed.
- 3 Rotate **⊙** to select a setting:
 - **[BEEP ON]**: Turn on the beep sound.
 - **[BEEP OFF]**: Turn off the beep sound.
- 4 Press **⊙** to confirm.

Turn display scroll on/off

For track information that is longer than the display panel: you can select to cut off the remainder of the text, or scroll to display the full text.

Note

- If any special characters are present in the MP3 track name or album name, it may not display correctly on the screen because these characters are not supported.
- Some WMA is protected by Digital Rights Management (DRM), it cannot be played on the unit.
- Folders/files exceed the supported limit of the unit are not displayed or played.

- 1 Press **MENU/DISP** for 3 seconds.
- 2 Press **▲** or **▼** repeatedly to until **[ROLL ON]** or **[ROLL OFF]** is displayed.
- 3 Turn **⊙** to select a setting:
 - **[ROLL ON]** (scroll on): Auto scroll during play.
 - **[ROLL OFF]** (scroll off): No auto scroll display.
- 4 Press **⊙** to confirm.

Reset

You can reset the unit to its default setting.

- 1 Detach the front panel (see 'Detach the front panel' on page 24).
- 2 Press the reset button by using a ball-point pen or a similar tool.
 - ↳ Preset adjustments such as preset channels and sound adjustments are erased.

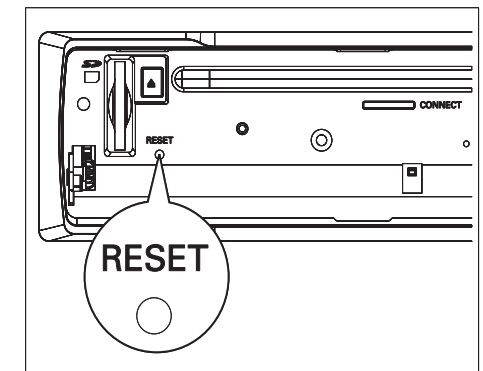

9 Additional information

Detach the front panel

You can detach the front panel to deter theft.

- 1 Press  to release the panel.
- 2 Press the left side of the panel rightward.

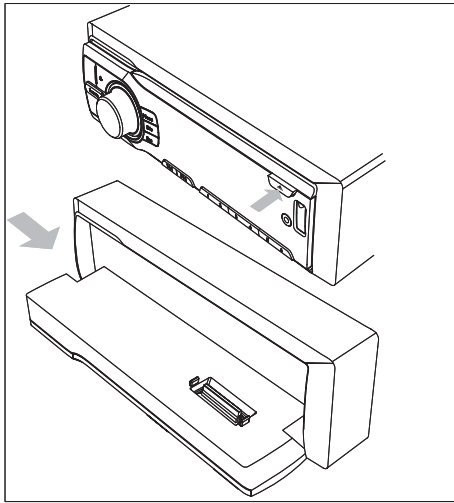

- 3 Pull the panel towards you to detach it from the chassis.
- 4 Store the panel in the supplied carry case to protect it from dirt or damage.

Replace fuse

If the fuse is damaged,

- 1 Check the electric connection.
- 2 Buy a fuse that matches the voltage of the damaged fuse.
- 3 Replace the fuse.

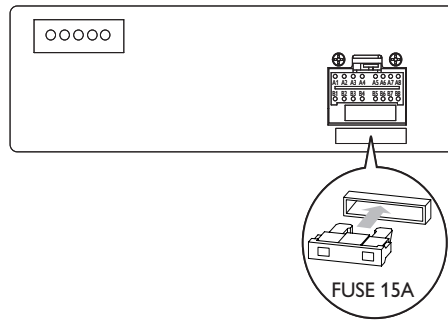

Note

- If the new fuse gets damaged again, there may be an internal malfunction. Consult your Philips dealer.

Remove the unit

You can remove the unit from the dashboard.

- 1 Detach the front panel.
- 2 Pull out the unit by using the removal keys.

Connect external sound source

- 1 Connect the external sound source to **MP3 LINK** socket by using a 3.5 mm cable.
- 2 Press **SOURCE** repeatedly until **[MP3 LINK]** is displayed.
- 3 Operate the external component (refer to the instructions supplied with the external component)

10 Product information

Note

- Product information is subject to change without prior notice.

| | |
|----------------------------|---|
| Power supply | 12 V DC (11 V - 16 V), negative ground |
| Fuse | 15 A |
| Suitable speaker impedance | 4 - 8 Ω |
| Maximum power output | 50 W x 4 channels |
| Continuous power output | 22 W x 4 channels (4 Ω 10% T.H.D.) |
| Pre-Amp output voltage | 2.0 V (USB play mode; 1 kHz, 0 dB, 10 k Ω load) |
| Subwoofer output voltage | 2.0 V (USB play mode; 61 Hz, 0 dB, 10 k Ω load) |
| Aux-in level | \geq 300 mV |
| Dimensions (W x H x D) | 182 x 53 x 112 MM |
| Weight | 1.0 kg |

Radio

| | |
|---|--|
| Frequency range - FM | 87.5 - 108.0 MHz (Europe) 87.5 - 107.9 MHz (American) |
| Frequency range - AM(MW) | 522 - 1620 KHz (Europe) 530 - 1710 HKz (American) |
| Usable sensitivity - FM | 8 μ V |
| Usable sensitivity - AM(MW) (S/N = 20 dB) | 30 μ V |
| Frequency response | 30 Hz - 15 KHz |
| Stereo separation | 30 db (1 kHz) |
| Signal/noise ratio | >55 dB |

Compatible USB devices:

- USB flash memory (USB 2.0 or USB1.1)
- USB flash players (USB 2.0 or USB1.1)
- memory cards

Supported formats:

- USB or memory file format FAT12, FAT16, FAT32 (sector size: 512 bytes)
- MP3 bit rate (data rate): 32-320 Kbps and variable bit rate
- WMA v9 or earlier
- Directory nesting up to a maximum of 8 levels
- Number of albums/ folders: maximum 99
- Number of tracks/titles: maximum 999
- ID3 tag v2.0 or later
- File name in Unicode UTF8 (maximum length: 128 bytes)

Unsupported formats:

- Empty albums: an empty album is an album that does not contain MP3/ WMA files, and is not be shown in the display.
- Unsupported file formats are skipped. For example, Word documents (.doc) or MP3 files with extension .dlf are ignored and not played.
- AAC, WAV, PCM audio files

- DRM protected WMA files (.wav, .m4a, .m4p, .mp4, .aac)
- WMA files in Lossless format
- ISO9660, Joliet
- Maximum title number: 512 (depending on file name length)
- Maximum album number: 255
- Supported sampling frequencies: 32 kHz, 44.1kHz, 48 kHz
- Supported Bit-rates: 32~256 (kbps), variable bit rates

11 Troubleshooting



Caution

- Never remove the casing of this unit.

To keep the warranty valid, never try to repair the system yourself.

If you encounter problems when using this unit, check the following points before requesting service. If the problem remains unsolved, go to the Philips web site (www.Philips.com/support). When you contact Philips, ensure that your unit is nearby and the model number and serial number are available (see 'Get started' on page 10).

No power or no sound.

- Car engine is not on. Turn the car engine on.
- Cable is not correctly connected. Check connections.
- Fuse is burnt. Replace fuse.
- Volume is too low. Adjust volume (see 'Adjust volume' on page 21).
- If the above solutions cannot help, press the RESET button.
- Ensure that the track played is of a compatible format.

Noise in broadcasts.

- Signals are too weak. Select other stations with stronger signals.
- Check the connection of the car antenna.
- Change broadcast from Stereo to mono.

Cannot play disc

- Ensure that the disc label is inserted with the printed side facing up.
- Wipe the disc with fibre cleaning cloth from the centre to the edge in a straight line.
- This disc may be defective. Play another disc.
- Ensure that the CD is a finalised CD/CD-R/CD-RW.

- Ensure that the CD is not encoded with copyright protection technologies.

The CD skips tracks

- Ensure that the CD is not damaged or dirty.
- Ensure that random mode is deactivated.

Preset stations lost.

- Battery cable is not correctly connected. Connect the battery cable to the terminal that is always live.

Display show ERR-1

- The disc, USB or SD device cannot be read in two minutes.

Display show ERR-3

- USB/SD/MMC data error.
- Disc is upside down. Ensure the printed side is facing up.

Display show ERR-5

- Communication error or component is damaged.

12 Glossary

M

MMC

MultimediaCard. A type of memory card with a flash memory.

MP3

A file format with a sound data compression system. MP3 is the abbreviation of Motion Picture Experts Group 1 (or MPEG-1) Audio Layer 3. With the MP3 format, one CD-R or CD-RW can contain about 10 times more data than a regular CD.

S

SD

Secure Digital. A type of memory card with a flash memory.

W

WMA (Windows Media Audio)

An audio format owned by Microsoft, is a part of Microsoft Windows Media technology. Includes Microsoft Digital Rights Management tools, Windows Media Video encoding technology, and Windows Media Audio encoding technology.

