

# Philips upper arm blood pressure monitor with Bluetooth® Smart DL8760



EN-US

BC

**PHILIPS**



Specifications are subject to change without notice.

© 2016 Koninklijke Philips N.V.

All rights reserved

Manufactured for:

Philips Consumer Lifestyle

A division of Philips Electronics North America Corporation

P.O. Box 10313, Stamford, CT 06904

4222.100.5747.1 (1/2016)

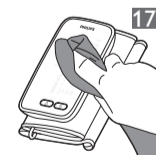
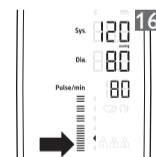
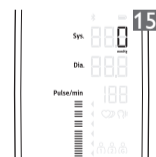
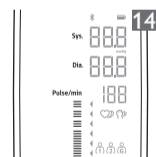
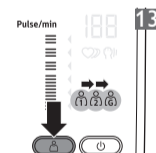
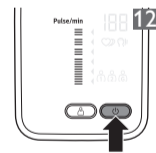
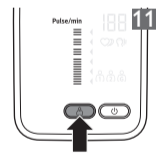
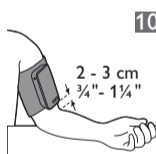
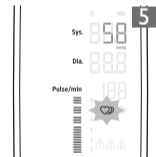
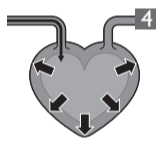
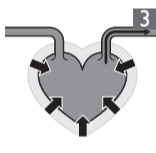
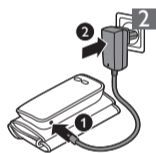

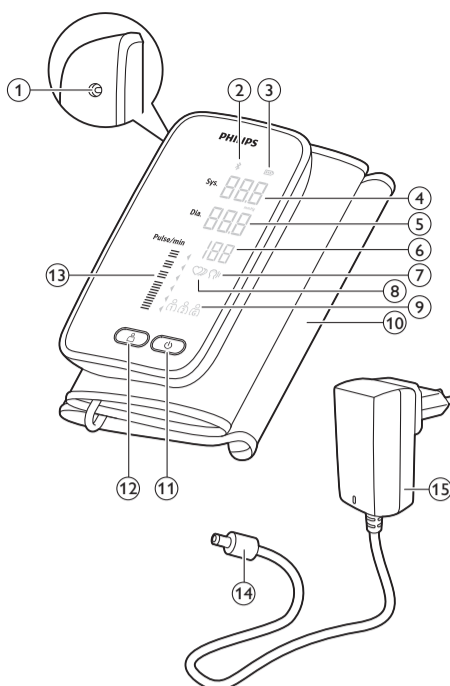

English

## General description (Fig. 1)

- 1 Socket for DC charger plug
- 2 Bluetooth® symbol
- 3 Battery symbol
- 4 Systolic blood pressure
- 5 Diastolic blood pressure
- 6 Heart rate
- 7 Movement detector
- 8 Heart rate/irregular heart rate detector
- 9 User IDs
- 10 Cuff
- 11 On button
- 12 User ID button
- 13 Blood pressure classification
- 14 DC plug
- 15 DC charger

## IMPORTANT SAFEGUARDS

### READ ALL INSTRUCTIONS BEFORE USING

When using electrical products, basic safety precautions should always be followed, including the following:

#### Warnings



- Please keep the unit out of reach of infants, children or pets, since inhalation or swallowing of small parts can be dangerous or even fatal.
- The device is only intended for measuring the blood pressure of adults.
- The device is not suitable for persons who have electrical implants.
- Do not use this blood pressure monitor on any arm where intravascular access or therapy (such as an intravenous drip or a blood transfusion), or an arterio-venous shunt (A-V shunt) is present. The temporary interference to blood flow by the blood pressure measurement could result in injury.
- If you had a mastectomy (breast amputation) do not use this blood pressure monitor on the arm on the side of the mastectomy. The inflating cuff can lead to pain, trauma and further injury in the arm on the side of the mastectomy.
- A device should never be left unattended when plugged in.
- Consult your physician if you suffer from illnesses prior to using the device.
- No modifications of this equipment are allowed. This may result in increased emissions or decreased immunity of the device.
- Do not use while bathing and within 20 minutes after taking a bath.
- Do not use the blood pressure monitor during charging as this can cause injury.
- Do not touch the output of the DC charger as this can cause injury.
- Do not dispose of built-in batteries in fire. Battery may explode or leak.
- Do not reach for a corded device that has fallen into water. Unplug immediately.
- The batteries used in this device may present a fire or chemical burn hazard if mistreated. Do not disassemble, heat above 100°C (212°F) or incinerate.
- Do not use an extension cord with this device.
- If you experience discomfort during a measurement, such as pain in the arm or other complaints, press the 'on' button to release the air immediately from the cuff. Loosen the cuff and remove it from your wrist.
- On the rare occasion of a fault causing the cuff to remain fully inflated during measurement, open the cuff immediately. Prolonged high pressure (cuff pressure >300mmHg or constant pressure >15mmHg for more than 3 minutes) applied to the arm, may lead to bruises (ecchymosis).
- Too frequent and consecutive measurements could cause disturbances in blood circulation and injuries.
- Beware of strangulation with the DC charger cord, particularly for children and infants due to cables.
- This device is not intended for use outside a home environment.

- Never use any accessories or parts from other manufacturers or that Philips does not specifically recommend. Using such accessories or parts could cause a hazardous situation for the user or damage to the device.

### **Caution**

- Only use this device for its intended purpose as described in this user manual.
- Do not confuse self-monitoring with self-diagnosis. This device allows you to monitor your blood pressure. Do not begin or end medical treatment based on the measurement results. Always consult your physician for treatment advice.
- Always check the device and cuff before you use it. Do not use the device or cuff if one of them is damaged, as this may cause injury.
- The effectiveness of this blood pressure monitor has not been established in pregnant (including pre-eclamptic) women.
- This device is not intended for use on extremities other than the arm or for functions other than obtaining a blood pressure measurement.
- Common arrhythmias (such as atrial or ventricular premature beats or atrial fibrillation) and peripheral artery disease / arteriosclerosis can affect the accuracy of this blood pressure monitor. Please consult your physician how to best use this blood pressure monitor if you suffer from any of these conditions.
- Do not take any therapeutic measures on the basis of a self-measurement. Never change prescribed medication without consulting your physician. Consult your physician if you have any questions about your blood pressure.
- If you are taking medication, consult your physician to determine the most appropriate time to measure your blood pressure.
- If the cuff pressure exceeds 300mmHg, the unit will deflate automatically. If the cuff does not deflate when pressures exceeds 300mmHg, detach the cuff from the arm and press the 'on' button to stop inflation.
- Do not attach the cuff on the same arm on which other monitoring medical electrical equipment is attached simultaneously, because this could cause temporary loss of function of those simultaneously-used monitoring medical electrical equipment.
- Never attach the cuff on injured skin, an injured arm or an arm under medical treatment as this can cause further injury.
- Do not use the device in case of existing polyester or nylon material allergies.
- This device is not washable. Never immerse the device in water and do not rinse it under the tap.
- This device is not suitable for continuous monitoring during medical emergencies or operations.
- This device cannot be used with HF (High Frequency) surgical equipment at the same time.
- Do not use the DC charger in or near a power outlet that contains an electric air freshener to prevent damage to the DC charger.
- Keep the device away from fire and heat sources, as the battery can overheat, causing fire or bursting. The battery could explode causing injury or death.
- After charging, remove the small plug from the device and remove the DC charger from the wall outlet.
- The equipment is not AP/APG equipment and is not suitable for use in the presence of a flammable anesthetic mixture with air, with oxygen or nitrous oxide.
- To avoid measurement errors, do not use the device near strong electromagnetic fields, radiated interference signal or electrical fast transient/burst signal. For example magnets, radio transmitters, microwave ovens.
- Use this device under the right environmental conditions as indicated in this user manual. If not, this could affect the performance, lifetime of the device and measurement results.
- Only use the DC charger supplied to charge the device.
- If you have any problems with this device, such as setting up, malfunction, maintaining or using, visit [www.philips.com/support](http://www.philips.com/support) or call 1-844-531-6861 for assistance.
- Do not open, disassemble or repair the device yourself.
- Dispose of accessories, detachable parts, and the ME equipment according to the local guidelines.
- Do not attempt to replace your blood pressure monitor's battery. It is built-in and not changeable.
- Avoid charging your blood pressure monitor in extremely high or low temperatures (see 'Specifications').
- Do not clean the blood pressure monitor when it is being charged. Always unplug the charger first before cleaning the blood pressure monitor.

### **Compliance with standards**

- The device meets the relevant standards for this type of Class II electrical medical equipment for home use.
- This Philips device complies with all applicable standards and regulations regarding exposure to electromagnetic fields and complies with IEC 60601-1-2.
- This Philips device complies with applicable standards and regulations of the FCC Rules.

SAVE THESE INSTRUCTIONS

### **Introduction**

Congratulations on your purchase and welcome to Philips! To fully benefit from the support that Philips offers, register your product at [www.philips.com/welcome](http://www.philips.com/welcome).

### **General**

The Philips upper arm blood pressure monitor with Bluetooth® Smart enables you to perform blood

pressure measurements, heart rate (pulse) measurements, transmit data via Bluetooth® Smart to your mobile device and display your personal measurement results in the Philips HealthSuite health app. The device can also be used as a standalone device.

This user manual contains important safety information and provides step-by-step instructions for using the blood pressure monitor. Read this information carefully before you use the device and save it for future reference.









Features:

- 3 7/16 in x 15/16 in / 86.5mm×24mm display with white backlight
- Measure-during-inflation technology
- Supports 2 users



### Intended use

The Philips upper arm blood pressure monitor is a digital monitor intended for use in measuring blood pressure and heart rate in adult patient population with arm circumference ranging from 8 ¾ - 16 ½ inch ( 22cm to 42cm ). The device is intended to be used in an indoor home environment.

### Display

Sym	Description	Explanation
<b>Sys.</b>	Systolic blood pressure	Maximum blood pressure, see also section systolic and diastolic pressure.
<b>Dia.</b>	Diastolic blood pressure	Minimum blood pressure, see also section systolic and diastolic pressure.
	Heart rate	Number of heartbeats per minute (pulse is typically equivalent to heart rate).
	Battery status	Indicates status of battery during charging.
<b>mmHg</b>	Measurement unit	Measurement unit of blood pressure.
	Irregular heart rate detector	Irregular heart rate detection during the measurement.
	User IDs	Start measurement for selected user, and transmit the measurement result.
	Movement detector	Moving during the measurement will result in an inaccurate result.
	Blood pressure classification	Classification of measured blood pressure following WHO system (see 'Blood pressure classification').
	Bluetooth® symbol	The device uses Bluetooth for communication.
	Heart rate detection	Heart rate detection during the measurement.

### Battery status indications

Battery symbol	Battery status
	The battery is almost empty.
	The battery is empty.

When you measure 3 times a day starting with a fully charged battery, the device can be used for about 20 days until a recharge is needed. In case of normal use, the battery can be charged around 300 times.

Note: Data will be lost when the battery is completely empty.

### Charging



The battery of this device is a built-in rechargeable li-polymer battery with a capacity of 1000 mAh. Use the original DC charger supplied to charge the battery. The DC charger transforms 100-240V AC to 6V DC.

When the battery is empty, it takes approx. 2 hours to fully charge the battery of the device.

- 1 Put the small DC plug in the socket of the device (Fig. 2).
- 2 Put the DC charger in the electrical outlet.

To ensure an optimal life time of the battery in the product it is recommended to store it 50% charged and re-charge every 3 months.

### Battery charging indications

Battery symbol	Battery charging indication
	Battery charging: half full
	Battery charging: almost full
	Battery fully charged

### Using the blood pressure monitor

This tubeless device uses the oscillometric method to measure blood pressure and heart rate. Before every measurement, the unit establishes a “zero point” equivalent to the atmospheric pressure. Then it starts inflating the cuff. During the measurement, the device detects the pressure oscillations in the blood vessels generated by the heart pumping blood through the body. These pressure oscillations are used to determine systolic and diastolic blood pressure as well as heart rate. While measuring heart rate, the device also determines the small variations between the individual heartbeats. If these variations exceed a pre-defined threshold, the irregular heart rate detector symbol lights up.

## Systolic and diastolic pressure

The heart consists of two large chambers - the ventricles - and two smaller chambers - the atria. The ventricles collect blood from the atria and expel it towards the peripheral beds of blood vessels within the body and the lungs. The atria collect blood from these peripheral beds and prime the ventricles.

When the ventricles contract and pump blood out of the heart, the blood pressure reaches its maximum value in the cycle, which is called systolic pressure (Fig. 3).

When the ventricles relax and are filled again with blood, the blood pressure reaches its minimum value in the cycle, which is called diastolic pressure (Fig. 4).

## Blood pressure classification

Consult a physician in case of questions about your blood pressure. Your physician can inform you:

- About your normal blood pressure range.
- If your measuring result falls out of the range.
- Whether your blood pressure has reached a dangerous level.

The following table shows the classification system for the blood pressure measurements used in this device. This system follows the classification system of the World Health Organisation (WHO).

Blood pressure classification following WHO system\*

Systolic pressure mmHg	Diastolic pressure mmHg		Blood pressure indicator
≥180	≥110	severe hypertension	red
160 - 179	100 - 109	moderate hypertension	orange
140 - 159	90 - 99	mild hypertension	yellow
130 - 139	85 - 89	high to normal blood pressure	green
120 - 129	80 - 84	normal blood pressure	green
< 120	< 80	optimal blood pressure	green
< 100	< 60	low blood pressure	green

\*Source: Chalmers J et al. WHO-ISH Hypertension Guidelines Committee. 1999 World Health Organization - International Society of Hypertension Guidelines for the Management of Hypertension. J Hypertens, 1999, 17:151-185.

## Irregular heart rate detector

The device is equipped with an irregular heart rate detector. An irregular heart rate is detected when the heart rhythm varies above a pre-defined level while the device is measuring the systolic and diastolic blood pressure. During each measurement, this device records the heartbeat intervals and calculates the standard deviation. If the standard deviation exceeds a pre-defined threshold, the irregular heart rate detector symbol lights up when the measurement results are displayed (Fig. 5).

**Caution: The appearance of the irregular heart rate detector symbol indicates that a heart rate irregularity was detected during measurement. Usually this is not a cause for concern. Due to the irregularity in your heart rate the blood pressure measurement might not be accurate, i.e. it might not reflect the 'real' situation in your body. However, if the symbol appears often, we recommend that you seek medical advice. Please note that the device does not replace a cardiac examination.**

## Preparing for use

### Pairing the blood pressure monitor to your mobile device

Note: Before you use the device for the first time, remove the protective foil from the display.

Note: To switch on the device for the first time, press the 'on' button for 3 seconds.

The blood pressure monitor is equipped with Bluetooth® Smart. You can receive your personal health data on a mobile device that is equipped with the Bluetooth® Smart function. Download the Philips HealthSuite health app from the App store or Google Play. Use the search term 'Philips HealthSuite health app'. The app is available for iOS® 8.0+ and Android™ 4.4+.

Note: You can only use the Philips HealthSuite health app to communicate with the device. It is not possible to use third party applications.

- 1 Download the Philips HealthSuite health app on your mobile device, start the app and follow the instructions to create a user profile and add the blood pressure monitor device.
- 2 Make sure the app is active and Bluetooth is on when pairing is in progress.
  - Keep the mobile device and the blood pressure monitor within transmission range (no more than 16 feet (5 meters) from each other, in the same room).
- 3 With the device turned off, press the 'on' button for 3 seconds, until it turns on in pairing mode.
  - These symbols are shown on the display alternatively, indicating that the connection is being established: (Fig. 6) and (Fig. 7).
- 4 When pairing is successful, the display shows this symbol: (Fig. 8). The app shows which user profile is assigned to you.
  - If the connection fails, the display shows this symbol: (Fig. 9).

- The blood pressure monitor has 2 user profiles. If both user profiles are in use, choose an existing profile to overwrite.
  - You can also delete both user profiles by pressing and holding the user ID button for approx. 10 seconds. The display of the device shows 'del'. All stored data is deleted and you have to follow steps 1-4 to pair and add a new user.
- 5 The blood pressure monitor shows the Bluetooth icon on the display as soon the connection has been established and switches off automatically after a few seconds.

When the blood pressure monitor is successfully paired with your mobile device, the blood pressure monitor automatically transmits your personal health data to your mobile device via Bluetooth® Smart.

---

Note: Only when the Philips HealthSuite health app is active, your personal health data can be transmitted.

---

## Measuring blood pressure

### Tips for proper measurement

- Rest for 5 minutes before you measure your blood pressure.
- Wait at least 3 minutes between measurements. This allows your blood circulation to recover.
- For a meaningful comparison, try to measure under similar conditions. For example, take daily measurements at approximately the same time, on the same arm, or as directed by your physician.
- For a good Bluetooth connection between the blood pressure monitor and your mobile device, make sure the two are close and there are no obstacles between the two devices. We recommend not to have the two devices farther than 16 feet (5 meters) apart.

We advise you not to take a measurement under the following circumstances, as this measurement may not be representative:

- Within 1 hour after eating or drinking
- Immediately after smoking
- While bathing and within 20 minutes after taking a bath
- While you are talking or moving your arm, hand or fingers
- In a very cold environment
- When you need to urinate

### Attaching the cuff

- 1 Remove all jewelry, such as watches and bracelets from your left arm.

---

Note: If your physician has diagnosed you with poor circulation in your left arm, use your right arm.

---

- 2 Roll or push up your sleeve to expose the skin. Make sure your sleeve is not too tight.
- 3 Hold your arm with your palm facing up and slide the cuff onto your left upper arm (Fig. 10).
- 4 Position the lower edge of the cuff  $\frac{3}{4}$ " -  $1\frac{1}{4}$ " (2-3 cm) above the crease of the elbow.
- 5 Fasten the cuff around your arm, leaving no extra room between the cuff and your skin. If the cuff is too loose, the measurement will not be accurate.
- The cuff will not cause any potential sensitization or irritation of the skin. The materials of the cuff have been tested and found to comply with requirements of ISO 10993-5:2009, ISO 10993-1:2009 and ISO 10993-10:2010.
- 6 Position yourself in the correct way for proper measurement:
- Make sure you do not wear tight clothing during measurement.
  - Sit comfortably with legs uncrossed, feet flat on the floor. Make sure that you sit upright with your back straight.
  - The center of the cuff should be at the same level as the heart.
  - Relax your wrist and hand. Do not bend your wrist back, clench your fist, or bend your wrist forward.

### Start measurement

- 1 Press the user ID button (Fig. 11) or 'on' button (Fig. 12) once, to switch on the device. The device automatically selects the previous user.
- To change the user profile, press the user ID button (Fig. 11) and select a different user (Fig. 13). Make sure the correct user is selected, so the measurement data is properly transmitted and stored. It is not possible to switch a user profile after a measurement.
  - When the health app is open, the app automatically selects the correct user profile. In this case, the user profile can be changed by either closing the app and reopening it again with the correct user profile, or by closing the app and using the user ID button.
  - Also a guest user can be selected. A guest user is a user without a user profile in the app. The guest user is for performing a measurement on other people without a user profile in the health app. Measurements performed when using the guest user are not stored in the memory nor transmitted to the app.
- 2 Attach the cuff to your arm (see 'Attaching the cuff') and make sure your posture is correct (see 'Tips for proper measurement').
- 3 Press the 'on' button to start the measurement (Fig. 12). All display characters are briefly shown on the display (Fig. 14). The device is ready for measurement and the number 0 appears (Fig. 15). Inflation of the cuff starts automatically.
- During inflation, the unit determines the systolic pressure and diastolic pressure as well as heart rate. This is shown by the heart rate detection symbol.
  - The movement detector will light up when movement is detected. This may result in inaccurate measurement results.

- 4 When the measurement is finalized, the cuff deflates and the measurement results are shown on the display (Fig. 16). To transmit the measurement results to the app, see section 'Transmit and store personal health data in the app'.

---

Note: If you experience discomfort during a measurement, such as pain in the arm or other complaints, press the 'on' button to release the air immediately from the cuff. Loosen the cuff and remove it from your arm.

---

- 5 Press the 'on' button to switch off the device.

---

Note: after 1 minute, the device will turn off automatically

---

If, after finishing the first measurement, another measurement is required, press the user ID button to select the correct user profile and follow steps 2-7.

---

Note: Wait at least 3 minutes between measurements. This allows your blood circulation to recover.

---

The device can store results of 60 blood pressure measurements for both user 1 and 2.

### **Transmit and store personal health data in the app**

---

Note: Your personal measurement data is only stored and displayed in the Philips HealthSuite health app.

---

- 1 Activate the Philips HealthSuite health app and Bluetooth on your mobile device directly after a measurement.
  - Keep the mobile device and the blood pressure monitor at transmission distance (no more than 16 feet (5 meters) from each other, in the same room).
- 2 Once successfully connected, the measurement results are being transmitted to the health app and the Bluetooth symbol lights up.
  - If the data transmission is successful, the measurement results are displayed in the health app.
  - If the data transmission fails, the Bluetooth symbol together with 'Err' is shown. The pending measurement data will be transmitted to your mobile device the next time it connects with your blood pressure monitor. You can also try to resend the data:
    - Activate the health app on your mobile device.
    - Press the user ID button or 'on' button to switch on the blood pressure monitor.
    - The measurement results will be automatically sent to your mobile device if the device has been added in the app.
    - When the blood pressure monitor connects via Bluetooth to the app of a user, the device will automatically select that user and measurements can only be done for that user.

### **Cleaning and storage**

**Caution: This device is not washable. Never immerse the device in water and do not rinse it under running water.**

**Caution: Avoid sudden movements and hard contacts with objects.**

**Caution: Never use compressed air, scouring pads, abrasive cleaning agents or aggressive liquids such as petrol or acetone to clean the device.**

- 1 Switch off the device and unplug the DC charger from the electrical outlet.
- 2 Use a slightly damp or dry cloth to wipe the surface of the display (Fig. 17).
- 3 Store the device in a cool, dry, and ventilated environment where it will not be crushed, banged or subject to damage. For further information, please refer to the transport and storage specifications (see 'Specifications').
- 4 Do not wrap the power cord around the device when you store it.

This device has no other user-serviceable parts. For assistance call 1-844-531-6861.

### **Accessories**

Philips accessories may be purchased at a store near you, or on our website

**[www.philips.com/store](http://www.philips.com/store)**.

### **Disposal**

This device contains a rechargeable battery which must be disposed of properly. Contact your local town or city officials for battery disposal information. You can also call 1-800-8-BATTERY or visit [www.rbc.com](http://www.rbc.com) for battery drop-off locations.

For assistance, visit our website

**[www.philips.com/support](http://www.philips.com/support)** or call 1-844-531-6861 toll free.

### **Recalibration and information**

This device is calibrated at the time of manufacture. If this blood pressure monitor is used according to instructions, recalibration will not be needed for 5 years (10000 use cycles).

Recalibration can be carried out by an appropriate authority or authorized service center. This calibration will be charged for by said authority.

If you need more information about the app, please visit **[www.philips.com/healthprograms](http://www.philips.com/healthprograms)**

### **Assistance**

For assistance, visit our website:

**[www.philips.com/support](http://www.philips.com/support)** or call toll free

**1-844-531-6861**

### **Full Two-Year Warranty**

Philips Electronics North America Corporation warrants each new Philips product, model DL8760, against defects in materials or workmanship for a period of two years from the date of purchase and agrees to repair or replace any defective product without charge.

**IMPORTANT:** This warranty does not cover damage resulting from accident, misuse or abuse, lack of reasonable care, the affixing of any attachment not provided with the product or loss

of parts or subjecting the product to any but the specified voltage.\*

NO RESPONSIBILITY IS ASSUMED FOR ANY SPECIAL, INCIDENTAL OR CONSEQUENTIAL DAMAGES.

In order to obtain warranty service, simply go to [www.philips.com/support](http://www.philips.com/support) or call toll-free 1-844-531-6861. It is suggested that for your protection you return shipments of product by insured mail, insurance prepaid. Damage occurring during shipment is not covered by this warranty.

NOTE: No other warranty, written or oral, is authorized by Philips Electronics North America Corporation. This warranty gives you specific legal rights, and you may also have other rights which vary from state to state. Some states do not allow the exclusion or limitation of incidental or consequential damages, so the above exclusion and limitations may not apply to you.

\* Read enclosed instructions carefully.

Manufactured for: Philips Consumer Lifestyle, A division of Philips Electronics North America Corporation, P.O. Box 10313, Stamford, CT 06904. PHILIPS and Philips Shield are registered trademarks of Koninklijke Philips N.V.

Distributed By: Philips Consumer Lifestyle A Division of Philips North America Corporation P.O. Box 10313, Stamford, CT 06904

©2016 Philips Electronics North America Corporation. All Rights Reserved.

## Troubleshooting

This chapter summarizes the most common problems you could encounter with the device. If you are unable to solve the problem with the information below, visit [www.philips.com/support](http://www.philips.com/support) for a list of frequently asked questions or call 1-844-531-6861 for assistance.

### Troubleshooting

Problem	Possible cause	Solution
My blood pressure fluctuates throughout the day.	Your measurement position, the conditions under which you measure or the time of measurement, are different during each measurement.	For a meaningful comparison, try to measure under similar conditions. For example, take measurements daily at approximately the same time, on the same arm, or as directed by a physician.
	Fluctuations of blood pressure during the day are normal.	Blood pressure fluctuates from minute to minute and normally shows a circadian rhythm over a 24-hour period, with highest readings in the afternoons and lowest readings at night. That is why, for comparable measurements, the measurements should be taken at approx. the same time of day.
	You are using medication.	The variations in blood pressure can be greater if you are using medication.
My blood pressure measurement from the hospital is different from the measurement at home.	You performed multiple measurements directly after each other.	Wait at least 3 minutes between measurements. This allows your blood circulation to recover.
	Multiple variables may affect your blood pressure such as the weather, emotions and exercise.	Pay attention when you measure your blood pressure at home. Check for instance:  If the cuff is attached properly. If the cuff is too tight or too loose. If the cuff is attached on the upper arm.  If you feel anxious or stressed, try to relax. Take a deep breath 2-3 times before you start a measurement. Advice: Rest for 5 minutes before you measure your blood pressure.
The result is different when I perform measurements on my right arm.	The blood pressure monitor is suitable to be used on both arms, but the measurement results on the right arm and left arm will differ.	For a meaningful comparison, try to measure under similar conditions and measure on the same arm every time.
The blood pressure monitor does not work when I press the 'on' button	The rechargeable battery is empty.	Recharge the battery (see 'Charging').
The light of the display dims and a battery symbol+Lo is showing	The battery is low.	Charge the battery (see 'Charging').



Problem	Possible cause	Solution
The display shows Err	Communication error.	Check if the app is on and try data transmission again.
The display shows E3	The cuff is not properly secured.	Refasten the cuff, wait 3 minutes and then measure again.
The display shows E10 or E11	The device detected motion, talking or the heart rate is too weak during the measurement.	Wait for 3 minutes and then measure again. Do not move during measurement.
The display shows E20	The device does not detect the heart rate signal.	Make sure the device is in contact with the skin. Loosen the clothing on the arm and measure again.
The display shows E21	The measurement failed.	Wait for 3 minutes and then measure again.
The display shows EExx	A system error occurred.	Retake the measurement. If the problem persists, call 1-844-531-6861 for assistance.
Data transmission or pairing failed.	Bluetooth is off.	Turn on Bluetooth on your mobile device.
	The Philips HealthSuite health app is off.	Press the icon on your mobile device to activate the health app.
	The blood pressure monitor and mobile device are more than 16 feet (5 meters) feet away from each other.	Place your mobile device closer to the blood pressure monitor.
	You selected the wrong profile on the blood pressure monitor.	Select the correct user profile on the blood pressure monitor before your measurement. Otherwise the data cannot be transmitted to your app. Repeat the measurement with the correct profile selected

## Specifications

Product name	Philips upper arm blood pressure monitor with Bluetooth® Smart
Power supply	3.7V 1000mAH built-in rechargeable li-polymer battery, 6V 1A DC charger
Display	Display with white LED backlight Visible area = 3 3/8" (L) x 15/16" (W) / 86.1 mm (L) x 24 mm (W)
Measurement method	Oscillometric method
Measurement range	Rated cuff pressure: 0mmHg - 300mmHg. Measurement pressure: 40mmHg - 230mmHg Heart rate: 40-199 beats per minute
Accuracy	Pressure: 41°F to 104°F / 5°C - 40°C within ± 3mmHg. Heart rate: ±5% of measurement result on display
Normal operating condition	Temperature: 41°F to 104°F / 5°C to 40°C. Relative humidity: ≤85%RH. Atmospheric pressure: 86kPa to 106kPa
Storage and transportation conditions	Temperature: -4°F to 140°F / -20°C to 60°C. Relative humidity: 10% to 93%. Atmospheric pressure: 50kPa to 106kPa
Measurement perimeter of the upper arm	About 8 ¾ - 16 ½ inch (22- 42 cm)
Net weight	Approx. 9.34 oz / 265g
External dimensions	Approx. 5 1/8" x 2 7/8" x 1 3/16" (130.9mm x 73mm x 29.4mm)
Accessories	DC charger, user manual
Mode of operation	Continuous operation
Degree of protection	Type BF applied part
Protection against ingress of water	IP22, This means: protected against access to hazardous parts with a finger and against vertically falling water drops when tilted up to 15 degrees.

Device classification      Battery Powered Mode:  
Internally Powered ME  
Equipment. DC charger  
charged mode: Class II  
ME Equipment

**Caution: No modification of this equipment is allowed.**

## Explanation of symbols

The warning signs and symbols are essential to ensure that you use this product safely and correctly and to protect you and others from injury. Below you find the meaning of the warning signs and symbols on the label and in the user manual.



Symbol for 'follow instructions for use'.



This symbol means that the part of the device that comes into physical contact with the user (also known as the applied part) is of type BF (Body Floating) according to IEC 60601-1. The applied part is the cuff.



Compliant with the Waste Electrical and Electronic Equipment/Restriction of the Use of Certain Hazardous Substances in Electrical and Electronic Equipment (WEEE) recycling directives.



Indicates manufacturing date.



Symbol for 'direct current'.



Symbol for the 'Bluetooth Combination mark'. The device uses Bluetooth for communication.



Indicates the manufacturer's serial number so that a specific medical device can be identified.



Indicates manufacturer's catalog number of the appliance.



Fuse T1A/250V  $\Phi$ 3.6\*10CCC.



Symbol for 'Class II Equipment'. The DC charger is double insulated (Class II) and complies with IEC 60601-1.



Symbol for indoor use only.



This means that this device emits non-ionizing radiation. All devices with RF transmitters or that use RF electromagnetic energy must have a label with this symbol.



Indicates caution. The user should consult the instructions for use for important cautionary information such as warnings and precautions that cannot, for a variety of reasons, be presented on the medical device itself.



This symbol on the device means: protected against access to hazardous parts with a finger and against vertically falling water drops when tilted up to 15 degrees.



Indicates the storage and transportation temperature limits to which the medical device can be safely exposed: -4°F to 140°F / -20°C to 60°C.



Indicates the relative humidity limits to which the device can be safely exposed: 10% to 93%.



Symbol for the 2 year Philips warranty.



This appliance contains a rechargeable battery which must be disposed of properly. See chapter 'Disposal' for more information.

## Electromagnetic emissions and immunity

The device is approved according to EMC safety standard IEC 60601-1-2. It is designed to be used in typical domestic environments.

### EMC Guidance

- The Blood Pressure Monitor needs special precautions regarding EMC and needs to be installed and put into service according to the EMC information provided in the accompanying documents.
- Wireless communications equipment such as wireless home network devices, mobile phones, cordless telephones and their base stations, walkie-talkies can affect this equipment and should be kept at least a distance equivalent to 3.3m (11 ft) away from the equipment.

Note: As indicated in IEC 60601-1-2:2007 for ME equipment, a typical cell phone with a maximum output power of 2 W yields equivalent to 3.3m (11 ft) at an immunity level of 3V/m.

### Table 1 Guidance and manufacturer's declaration – electromagnetic emissions – for all ME equipment and ME systems

Guidance and manufacturer's declaration – electromagnetic emissions

The device is intended for use in the electromagnetic environment specified below. The customer or the user of the device should assure that it is used in such an environment.

Emissions test	Compliance	Electromagnetic environment – guidance
RF emissions CISPR 11	Group 1	The device must emit electromagnetic energy in order to perform its intended function. Nearby electronic equipment may be affected.

Emissions test	Compliance	Electromagnetic environment - guidance
RF emissions CISPR 11	Class B	
Harmonic emissions IEC 61000-3-2	Not applicable	
Voltage fluctuations/flicker emissions IEC 61000-3-3	Not applicable	

### Table 2 Guidance and manufacturer's declaration – electromagnetic immunity – for all ME equipment and ME systems

Guidance and manufacturer's declaration – electromagnetic immunity

The device is intended for use in the electromagnetic environment specified below. The customer or the user of the device should assure that it is used in such an environment.

Immunity test	IEC 60601 test level	Compliance level	Electromagnetic environment - guidance
Electrostatic discharge (ESD) IEC 61000-4-2	±6 kV contact ±8 kV air	±6 kV contact ±8 kV air	Floors should be wood, concrete or ceramic tile. If floors are covered with synthetic material, the relative humidity should be at least 30%.
Electrical fast transient/burst IEC 61000-4-4	±2 kV for power supply lines ±1 kV for input/output lines	±2 kV for power supply lines	Electrical power quality should be that of a typical commercial or hospital environment.
Surge IEC 61000-4-5	±1 kV line(s) to line(s) ±2 kV line(s) to earth	±1 kV line(s) to line(s)	Electrical power quality should be that of a typical commercial or hospital environment.
Voltage dips, short interruptions and voltage variations on power supply input lines IEC 61000-4-11	<5% UT (>95% dip in UT) for 0.5 cycle 40% UT (60% dip in UT) for 5 cycles 70% UT (30% dip in UT) for 25 cycles <5% UT (>95% dip in UT) for 5 s	<5% UT (>95% dip in UT) for 0.5 cycle 40% UT (60% dip in UT) for 5 cycles 70% UT (30% dip in UT) for 25 cycles <5% UT (>95% dip in UT) for 5 s	Electrical power quality should be that of a typical commercial or hospital environment. If the user of the device requires continued operation during power interruptions, it is recommended that the device be powered from an uninterruptible power supply or a battery.
Power frequency (50/60-Hz) magnetic field IEC 61000-4-8	3A/m	3A/m	Power frequency magnetic fields should be at levels characteristic of a typical location in a typical commercial or hospital environment.

Note: UT is the AC electrical voltage prior to application of the test level.

### Table 4 Guidance and manufacturer's declaration – electromagnetic immunity – for ME equipment and ME systems that are not life supporting

Guidance and manufacturer's declaration – electromagnetic immunity .The device is intended for use in the electromagnetic environment specified below. The customer or the user of the device should assure that it is used in such an environment.

IMMUNITY test	IEC 60601 TEST LEVEL	Compliance level
Conducted RF IEC 61000-4-6	3 Vrms 150 kHz to 80 MHz	3 Vrms
Radiated RF IEC 61000-4-3	3 V/m 80 MHz to 2.5 GHz	3 V/m

#### Electromagnetic environment - guidance

Portable and mobile RF communications equipment should be used no closer to any part of the device, including cables, than the recommended separation distance calculated from the equation applicable to the frequency of the transmitter.

Recommended separation distance:

$$d = 1.167 \sqrt{P}$$

$$d = 1.167 \sqrt{P} \text{ 80 MHz to 800MHz}$$

$$d = 2.333 \sqrt{P} \text{ 800 MHz to 2.5 GHz}$$

where  $P$  is the maximum output power rating of the transmitter in watts (W) according to the transmitter manufacturer and  $d$  is the recommended separation distance in metres (m).

Field strengths from fixed RF transmitters, as determined by an electromagnetic site survey (a), should be less than the compliance level in each frequency range (b).

Interference may occur in the vicinity of equipment marked with the following symbol:



NOTE 1 At 80 MHz and 800 MHz, the higher frequency range applies.

NOTE 2 These guidelines may not apply in all situations. Electromagnetic propagation is affected by absorption and reflection from structures, objects and people.

(a) Field strengths from fixed transmitters, such as base stations for radio (cellular/cordless) telephones and land mobile radios, amateur radio, AM and FM radio broadcast and TV broadcast cannot be predicted theoretically with accuracy. To assess the electromagnetic environment due to fixed RF transmitters, an electromagnetic site survey should be considered. If the measured field strength in the location in which the device is used exceeds the applicable RF compliance level above, the device should be observed to verify normal operation. If abnormal performance is observed, additional measures may be necessary, such as re-orienting or relocating the device.

(b) Over the frequency range 150 kHz to 80 MHz, field strengths should be less than 3V/m.

### **Table 6 Recommended separation distances between portable and mobile RF communications equipment and the ME equipment or ME system – for ME equipment and ME systems that are not life supporting**

Recommended separation distances between portable and mobile RF communications equipment and the device.

The device is intended for use in an electromagnetic environment in which radiated RF disturbances are controlled. The customer or the user of the device can help prevent electromagnetic interference by maintaining a minimum distance between portable and mobile RF communications equipment (transmitters) and the device as recommended below, according to the maximum output power of the communications equipment.

	Separation distance according to frequency of transmitter (m)		
Rated maximum output power of transmitter (W)	150 kHz to 80 MHz $d = 1.167 \sqrt{P}$	80 MHz to 800 MHz $d = 1.167 \sqrt{P}$	800 MHz to 2.5 GHz $d = 2.333$
0.01	0.117	0.117	0.233
0.1	0.369	0.369	0.738
1	1.167	1.167	2.333
10	3.690	3.690	7.378
100	11.67	11.67	23.33

For transmitters rated at a maximum output power not listed above, the recommended separation distance  $d$  in metres (m) can be estimated using the equation applicable to the frequency of the transmitter, where  $P$  is the maximum output power rating of the transmitter in watts (W) according to the transmitter manufacturer.

NOTE 1 At 80MHz and 800MHz, the separation distance for the higher frequency range applies.

NOTE 2 These guidelines may not apply in all situations. Electromagnetic propagation is affected by absorption and reflection from structures, objects and people.

### **FCC Compliance information**

This device complies with Part 15 of the FCC Rules. Operation is subject to the following two conditions: (1) this device may not cause harmful interference, and (2) this device must accept any interference received, including interference that may cause undesired operation.

FCC ID 2AEFK-DL8760

### **Radio interference**

This equipment has been tested and found to comply with the limits for a Class B digital device, pursuant to Part 15 of the FCC Rules. These limits are designed to provide reasonable protection against harmful interference in a residential installation. This equipment generates, uses and can radiate radio frequency energy and, if not installed and used in accordance with the instructions, may cause harmful interference to radio communications. However, there is no guarantee that interference will not occur in a particular installation.

If this equipment does cause harmful interference to radio or television reception, which can be determined by turning the equipment off and on, the user is encouraged to try to correct the interference by one or more of the following measures:

- Reorient or relocate the receiving antenna.
- Increase the separation between the equipment and receiver.
- Connect the equipment to an outlet on a circuit different from that to which the receiver is connected.
- Consult the dealer or an experienced radio/TV technician for help.

### **RF Radiation exposure statement**

This equipment complies with FCC RF radiation exposure limits set forth for an uncontrolled environment. For handheld/body-worn operation, this equipment has been tested and meets the FCC RF exposure guidelines. This transmitter must not be co-located or operating in conjunction with any other antenna or transmitter. Use of other accessories may not ensure compliance with FCC RF guidelines.

Do not attempt to repair or modify this equipment. Any repairs or alterations made by the user to the equipment may void the warranty and compliance of the equipment. Changes or modifications made to this equipment not expressly approved by Philips may void the FCC authorization to operate this equipment. For assistance visit our website [www.philips.com/support](http://www.philips.com/support) or call toll-free 1-844-531-6861.

**BlueTooth wordmark**

The BlueTooth® Smart wordmark and logos are registered trademarks owned by Bluetooth SIG, Inc. and any use of such marks by Philips is under license.

**App Store and iPhone**

App Store and iPhone are trademarks of Apple Inc., registered in the U.S. and other countries. App Store is a service mark of Apple Inc.

**Google Play and Android**

Google Play and Android are trademarks of Google Inc.