

PHILIPS

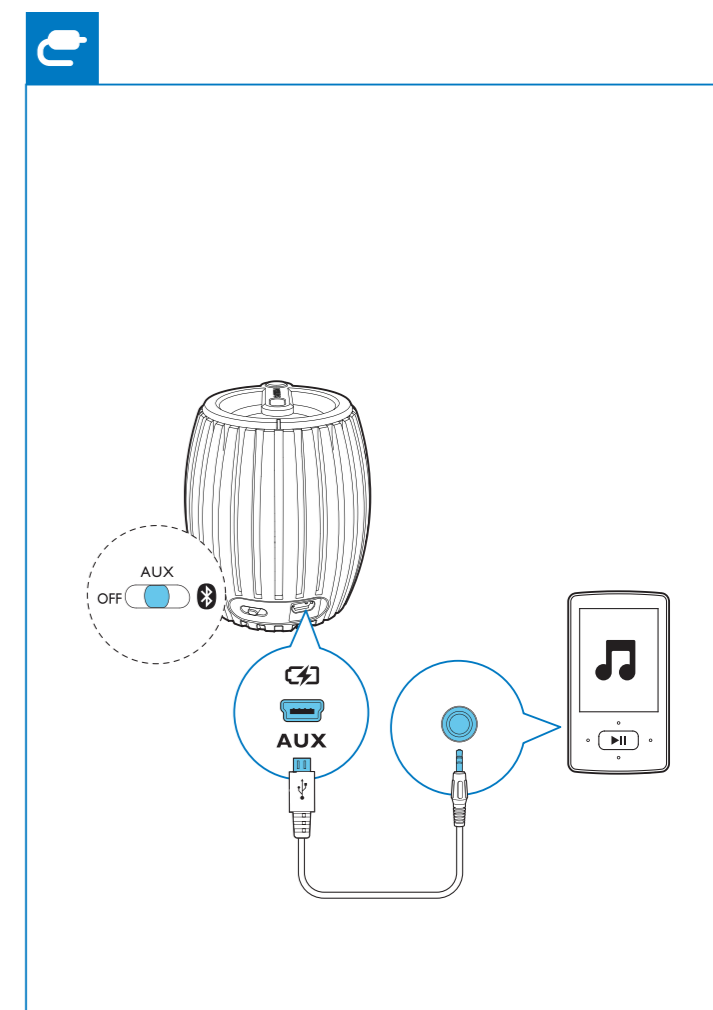
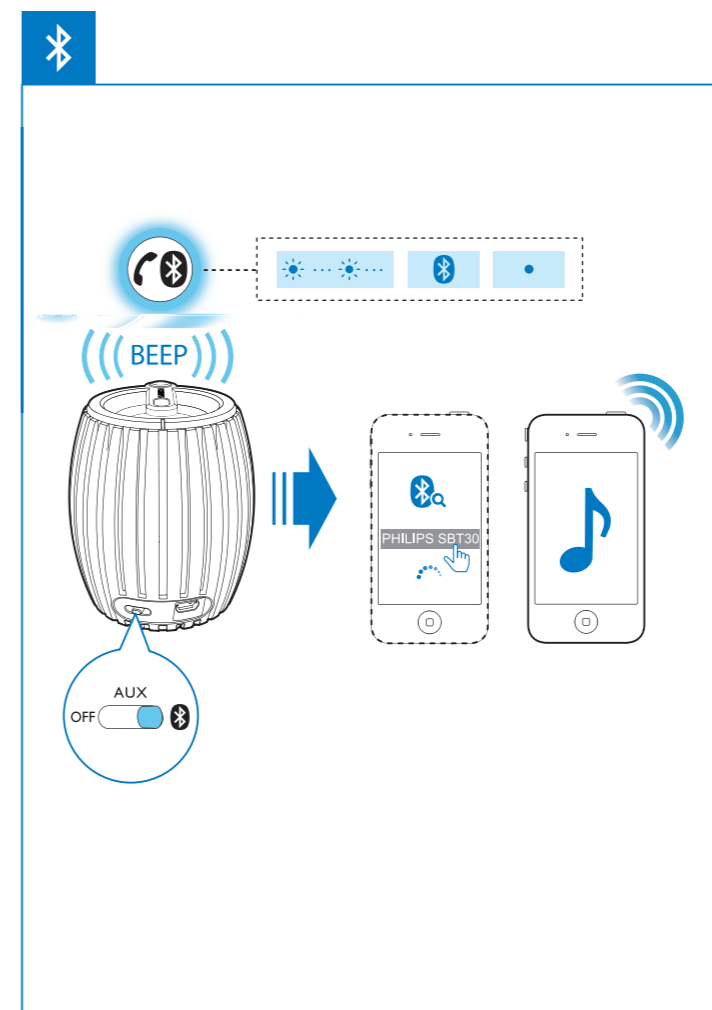
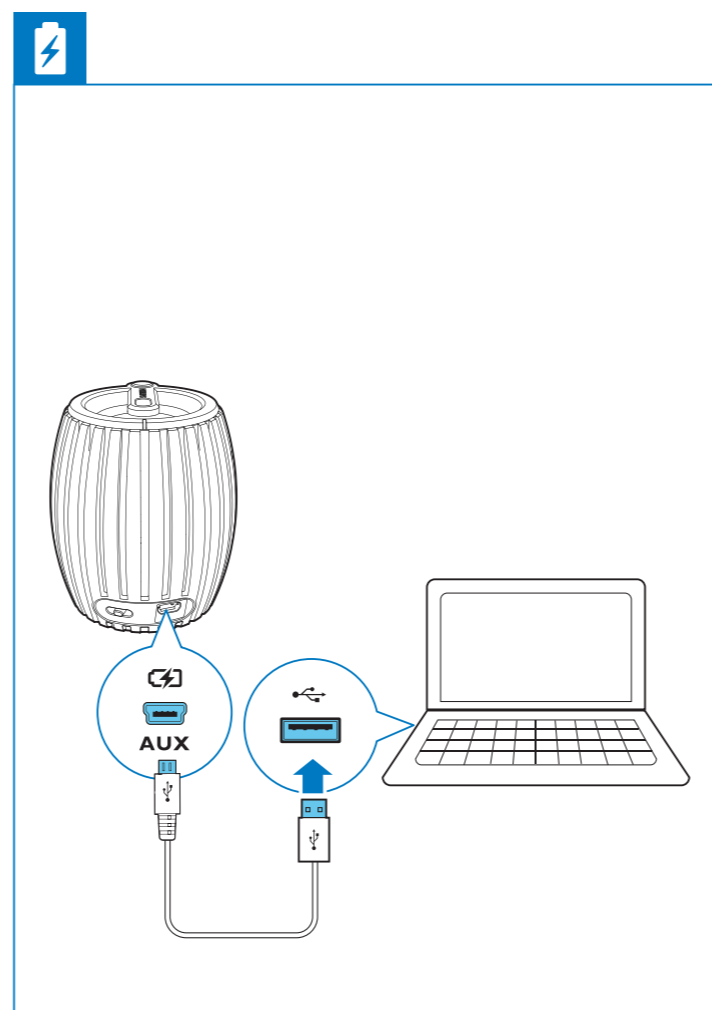
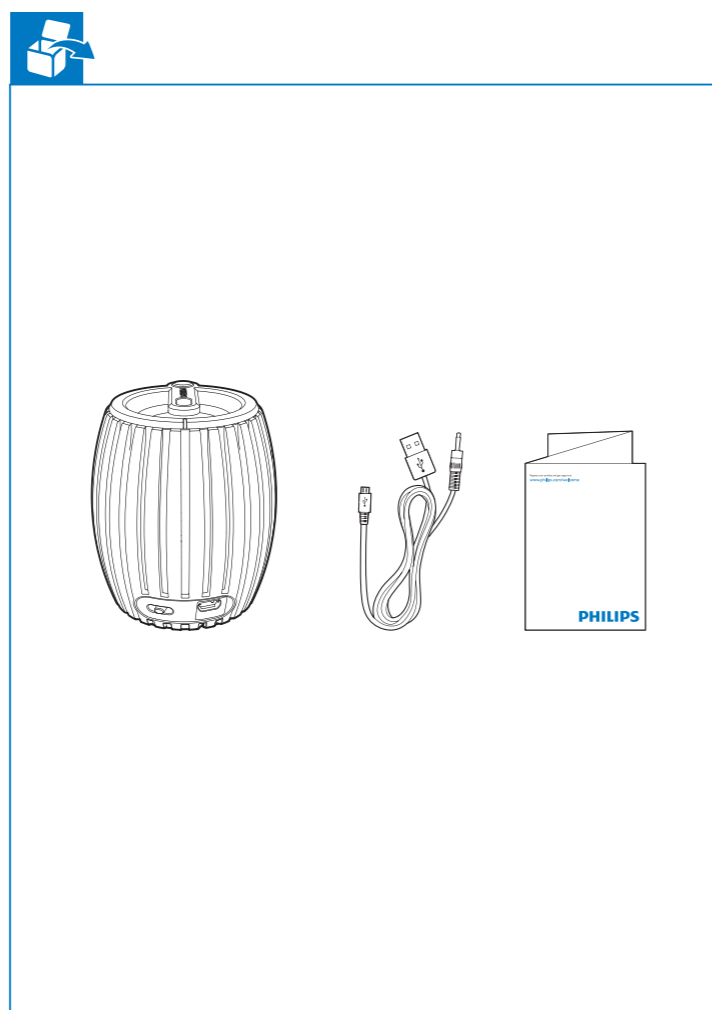

1 Important

Safety

Important Safety Instructions

- ① Read these instructions.
- ② Keep these instructions.
- ③ Heed all warnings.
- ④ Follow all instructions.
- ⑤ Do not use this apparatus near water.
- ⑥ Clean only with dry cloth.
- ⑦ Do not block any ventilation openings. Install in accordance with the manufacturer's instructions.
- ⑧ Do not install near any heat sources such as radiators, heat registers, stoves, or other apparatus (including amplifiers) that produce heat.
- ⑨ Only use attachments/accessories specified by the manufacturer.
- ⑩ Refer all servicing to qualified service personnel. Servicing is required when the apparatus has been damaged in any way, such as power-supply cord or plug is damaged, liquid has been spilled or objects have fallen

into the apparatus, the apparatus has been exposed to rain or moisture, does not operate normally, or has been dropped.

- ⑪ Apparatus shall not be exposed to dripping or splashing.
- ⑫ Do not place any sources of danger on the apparatus (e.g. liquid filled objects, lighted candles).

Warning

- Never remove the casing of this apparatus.
- Never lubricate any part of this apparatus.
- Never place this apparatus on other electrical equipment.

Notice

Any changes or modifications made to this device that are not expressly approved by Philips Consumer Lifestyle may void the user's authority to operate the equipment.

Notice for the USA and Canada

This device complies with Part 15 of the FCC Rules and RSS standard of Industry Canada. Operation is subject to the following two conditions:

- 1 this device may not cause harmful interference, and
- 2 this device must accept any interference received, including interference that may cause undesired operation.

This equipment has been tested and found to comply with the limits for a Class B digital device, pursuant to part 15 of the FCC Rules and ICES-003 of Industry Canada.

These limits are designed to provide reasonable protection against harmful interference in a residential installation. This equipment generates, uses, and can radiate radio frequency energy and, if not installed and used in accordance with the instruction manual, may cause harmful interference to radio communications.

However, there is no guarantee that interference will not occur in a particular installation. If this equipment does cause harmful interference to radio or television reception, which can be determined by turning the equipment off and on, the user is encouraged to try to correct the interference by one or more of the following measures:

- Relocate the receiving antenna.
- Increase the separation between equipment and receiver.
- Connect the equipment into an outlet on a circuit different from that to which the receiver is connected.
- Consult the dealer or an experienced radio/TV technician for help.

RF Radiation Exposure Statement: This equipment complies with FCC's and IC's RF radiation exposure limits set forth for an uncontrolled environment. The antenna(s) used for this transmitter must be installed and operated to provide a separation distance of at least 20 cm from all per-

sons and must not be collocated or operating in conjunction with any other antenna or transmitter. Installers must ensure that 20cm separation distance will be maintained between the device (excluding its handset) and users.

Disposal of your old product

Your product is designed and manufactured with high quality materials and components, which can be recycled and reused.

Never dispose of your product with other household waste. Please inform yourself about the local rules on the separate collection of electrical and electronic products and batteries. The correct disposal of these products helps prevent potentially negative consequences on the environment and human health.

Your product contains batteries, which cannot be disposed of with normal household waste. Please inform yourself about the local rules on separate collection of batteries. The correct disposal of batteries helps prevent potentially negative consequences on the environment and human health. Please visit www.recycle.philips.com for additional information on a recycling center in your area.

Always bring your product to a professional to remove the built-in battery.



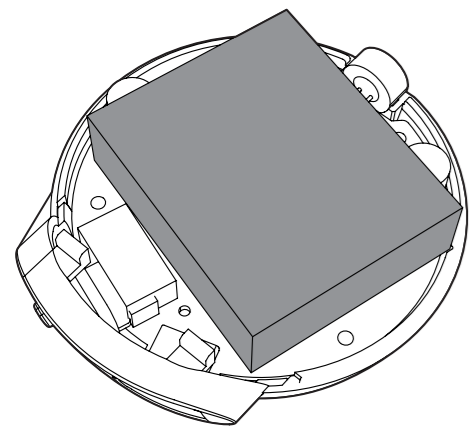

Environmental information

All unnecessary packaging has been omitted. We have tried to make the packaging easy to separate into three materials: cardboard (box), polystyrene foam (buffer) and polyethylene (bags, protective foam sheet.)

Your system consists of materials which can be recycled and reused if disassembled by a specialized company. Please observe the local regulations regarding the disposal of packaging materials, exhausted batteries and old equipment.

Be responsible
Respect copyrights

The making of unauthorized copies of copy-protected material, including computer programs, files, broadcasts and sound recordings, may be an infringement of copyrights and constitute a criminal offence. This equipment should not be used for such purposes.

Note

- The type plate is located on the bottom of the apparatus.

2 Your Bluetooth Speaker

Congratulations on your purchase, and welcome to Philips! To fully benefit from the support that Philips offers, register your product at www.philips.com/welcome.

Introduction

With this speaker, you can enjoy audio from the compatible Bluetooth device or your PC/ Mac.

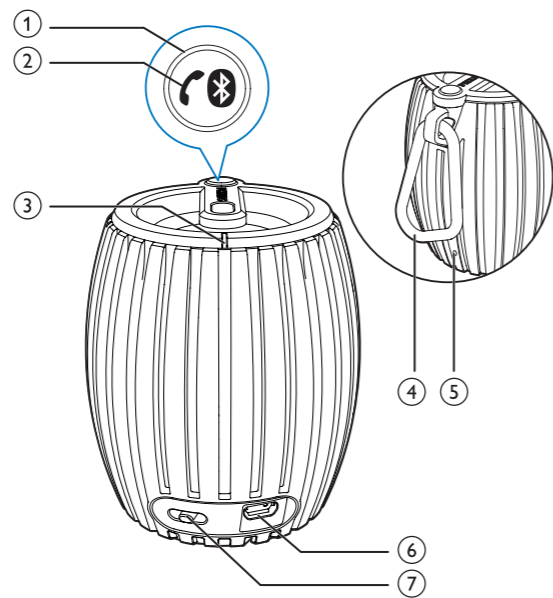

3 Get started

Always follow the instructions in this chapter in sequence. If you contact Philips, you will be asked for the model and serial number of this apparatus. The model number and serial number are on the bottom of the apparatus. Write the numbers here:

Model No. _____

Serial No. _____

Power supply (🔋)

The speaker can operate on built-in rechargeable battery.

To recharge the built-in battery:

Connect mini USB socket (⑥) with PC through supplied USB cable.

↳ The power indicator (③) turns on. (white)

- The power indicator turns off when it's fully charged.

The carabiner

The carabiner (④) is used for easy carrying or hanging, not for climbing support or fall protection.

4 Play

Play from a Bluetooth device (📶)

Note

- The effective operation range between the speaker and your Bluetooth device is approximately 10 meters (30 feet).

- Slide (⑦) towards 📶 to select Bluetooth audio source. ↳ The Bluetooth indicator (①) flashes. (Blue)
- Activate the Bluetooth function in your Bluetooth device.

- Select "PHILIPS SBT30" on your Bluetooth device for pairing.
 - ↳ The speaker beeps twice and the Bluetooth indicator (①) stays steadily on. (Blue)
 - For some devices, you may need to input "0000" as pairing password.
- Start music play on your Bluetooth device.

When there is an incoming call:

- Press Bluetooth button (②) to pick up the call.
- Press Bluetooth button (②) again to hang up the call.

Tip

- You can speak to the MIC (⑤) to get the best speakerphone performance.

Play from an external device (🔌)

- Slide (⑦) towards AUX to select Aux-in audio source.
 - ↳ The power indicator (③) turns red.
- Connect your speaker with an external device through the supplied USB cable.
 - ↳ The power indicator (③) turns orange.
- Start music play on your device.

5 Product information

Note

- Product information is subject to change without prior notice.

Specifications

Amplifier	
Rated Output Power	2W RMS
Signal to Noise Ratio	>70dB
Aux-in Link	600 mV RMS, 10 kohm

Bluetooth	
Bluetooth specification	V2.1+EDR
Supported Profiles	HFPv1.6, AD2Pv1.2, HSPv1.2
Advanced features	Echo and noise cancellations

General information	
DC power input	USB: 5V, 500mA
Built-in Li-Polymer battery	3.7V 1000mAh
Battery working time	>8 hours
Dimensions- Main Unit (diameter x height)	D56mm * H80mm
Weight- Main Unit	0.15 kg

6 Troubleshooting

Warning

- Never remove the casing of this apparatus.

To keep the warranty valid, never try to repair the system yourself.

If you encounter problems when using this apparatus, check the following points before requesting service. If the problem remains unsolved, go to the Philips web site (www.philips.com/welcome). When you contact Philips, ensure that the apparatus is nearby and the model number and serial number are available.

No power

- Recharge your speaker.

No sound

- Adjust volume on your mobile phone or PC/Mac.
- Make sure that your Bluetooth mobile phone is within the effective operation range.
- Check if you have selected the correct audio source.

No response from the speaker

- Restart the speaker.