

CD Soundmachine

AZ 1004



Let's make things better.



PHILIPS

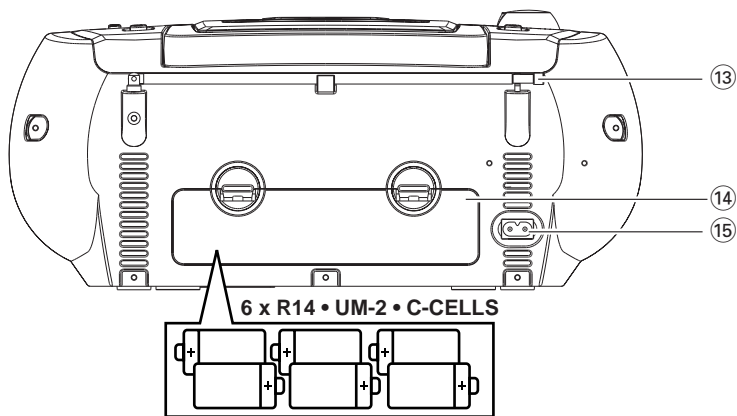
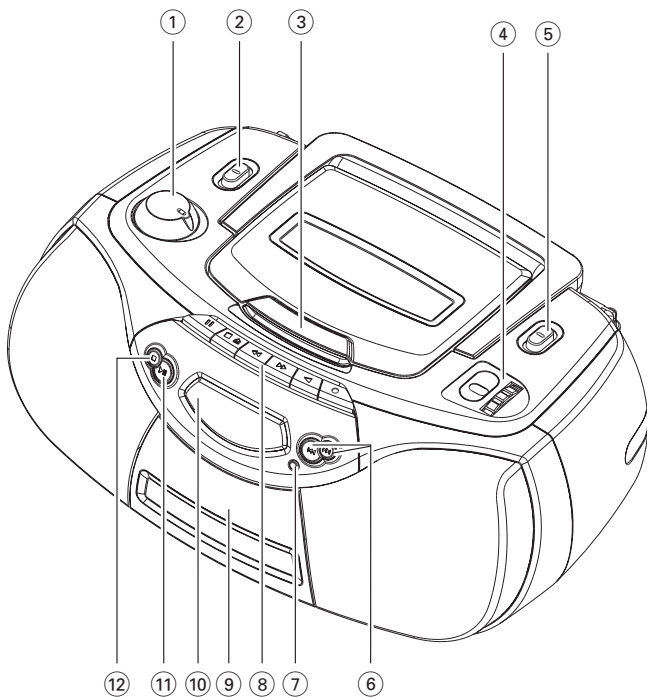

2



3



4



5



6



7

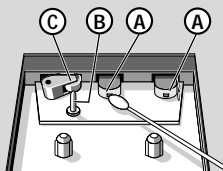
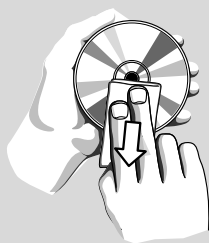
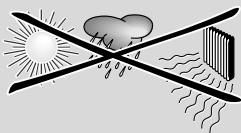

AUSTRALIA - Philips 3 years Manufacturers Warranty for Australia only

These warranty conditions are valid for the following consumer electronics products: **Colour Televisions, Video Cassette Recorders, CD Players and Recorders, DVD Players and Recorders, Audio Systems and Portable Audio.**

The benefits given to the purchaser by this warranty are in addition to all other rights and remedies which the purchaser has in respect of the product under the Trade Practices Act or other Commonwealth or State Law.

Philips Consumer Electronics warrants its products to the purchaser as follows and subject to the stated conditions.

3 YEARS **free Repair Service**

Colour Televisions, CD Players and Recorders, DVD Players and Recorders and Audio Systems.

3 YEARS **free Replacement – at your Retailer**

All Portable Audio products and all Video Cassette recorders (VCRs) only.

Conditions of Repair Warranty

1. All claims for warranty service should be made to your nearest Philips Authorised Service Centre. Reasonable evidence of date of purchase must be provided.
2. This warranty extends only to defects in material or workmanship occurring under normal use of the product when operated in accordance with the instructions.
3. This warranty applies for original purchase only. It is not transferable if sold.
4. Home service within the normal service area of one of our Authorised Service Centres will only be provided for television receivers with screen size 48 cm and above. All other products are to be taken or sent to the workshop of your nearest Authorised Service Centre (at Consumer's expense).
5. This Manufacturers Warranty is limited to 3 months for above listed Consumer Electronics products if used in commercial applications.
6. Philips may, at its discretion choose to replace rather than repair any product covered by this warranty.
7. This Manufacturers Warranty is neither transferable nor valid in countries other than Australia.

This warranty does not cover:

- a) Mileage or travelling time, pickup or delivery, installations and cost of insurance.
- b) Mileage or travel outside the normal service area covered by selected Authorised Service Centre.
- c) Service costs arising from failure to correctly adjust the controls of the product or to observe the instructions, or inspections that reveal that the product is in normal working order.

d) Product failures caused by misuse, neglect, accidental breakage, transit damage, inexpert repairs or modification by un-authorised persons, external fires, lightning strikes, floods, vermin infestation or liquid spillage.

e) Cleaning of video or audio heads.

f) Inadequate receiving antennae.

g) Replacement of worn or used batteries or other consumables.

h) Consumer products used in commercial applications (This warranty is limited to 3 months only).

i) Second hand products.

The conditions contained in this warranty card replace and override the provision of the Philips World-Wide Guarantee for products purchased in Australia and used in Australia.

Philips Authorised Service Centres

Service is provided through 200 accredited Authorised Service Centres throughout Australia. For direct contact with your nearest recommended Authorised Service Centre in major cities:

Adelaide	Launceston
Brisbane	Melbourne
Canberra	Newcastle
Geelong	Perth
Gold Coast	Sydney
Hobart	Wollongong

or to find the location of your nearest recommended Authorised Service Centre outside the above cities please call our National Service telephone number:

1300 361 392

Please record the following information for your records and keep in a safe place.

Model number:

Serial number:

Date of purchase:

Retailer:

We recommend you retain your purchase receipt to assist in any warranty claim.

Philips Consumer Electronics
a division of Philips Electronics Australia Limited
ABN 24 008 445 743,
Level 2, 65 Epping Road NORTH RYDE NSW 2113

NEW ZEALAND - Guarantee and Service for New Zealand

Thank-you for purchasing this quality Philips product.

Philips New Zealand Ltd guarantees this product against defective components and faulty workmanship for a period of 12 months. Any defect in materials or workmanship occurring within 12 months from the date of purchase subject to the following conditions will be rectified free of charge by the retailer from whom this product was purchased.

Conditions

1. The product must have been purchased in New Zealand. As proof of purchase, retain the original sales docket indicating the date of purchase.
2. The guarantee applies only to faults caused by defective components, or faulty workmanship on the part of the manufacturer.
3. The guarantee does not cover failures caused by misuse, neglect, normal wear and tear, accidental breakage, use on the incorrect voltage, use contrary to operating instructions, or unauthorised modification to the product or repair by an unauthorised technician.
4. Reasonable evidence (in the form of a sales docket) must be supplied to indicate that the product was purchased no more than 12 months prior to the date of your claim.
5. In the event of a failure, Philips shall be under no liability for any injury, or any loss or damage caused to property or products other than the product under guarantee.

This guarantee does not prejudice your rights under common law and statute, and is in addition to the normal responsibilities of the retailer and Philips.

How to claim

Should your Philips product fail within the guarantee period, please return it to the retailer from whom it was purchased. In most cases the retailer will be able to satisfactorily repair or replace the product.

However, should the retailer not be able to conclude the matter satisfactorily, or if you have other difficulties claiming under this guarantee, please contact

The Guarantee Controller

Philips New Zealand Ltd.

✉ P.O. Box 41.021

Auckland

☎ (09) 84 94 160

fax ☎ (09) 84 97 858

Mexico



Es necesario que lea cuidadosamente su instructivo de manejo.



Descripción:	Radio grabadora AM/FM con reproductor de CD
Modelo:	AZ 1004/01, AZ1004/16
Alimentación:	110-127/220-240 V~ ;50-60 Hz
Consumo:	12 W
Importador:	Philips Mexicana, S.A. de C.V
Domicilio:	Av. La Palma No. 6 Col. San Fernando La Herradura Huixquilucan
Localidad y Telefono:	Edo. de México C.P. 52784 Tel. 52 69 90 00
Exportador:	Philips Electronics HK, Ltd.
País de Origen:	China
Nº de Serie:	_____

AVISO IMPORTANTE

Philips Mexicana, S.A. de C.V. no se hace responsable por daños o desperfectos causados por:

- Maltrato, descuido o mal uso, presencia de insectos o roedores (cucarachas, ratones etc.).***
- Cuando el aparato no haya sido operado de acuerdo con el instructivo del uso, fuera de los valores nominales y tolerancias de las tensiones (voltaje), frecuencia (ciclaje) de alimentación eléctrica y las características que deben reunir las instalaciones auxiliares.***
- Por fenómenos naturales tales como: temblores, inundaciones, incendios, descargas eléctricas, rayos etc. o delitos causados por terceros (choques asaltos, riñas, etc.).***

POLIZA DE GARANTIA

ESTA POLIZA ES GRATUITA

Este aparato ha sido cuidadosamente diseñado y se ha fabricado con los mejores materiales bajo un estricto control de calidad, garantizando su buen funcionamiento por los periodos establecidos según el aparato (ver lista en la parte inferior) **a partir de la entrega del aparato al consumidor.**

Esta póliza incluye la reparación o reposición gratuita de cualquier parte o componente que eventualmente fallase y la mano de obra necesaria para su reparación, misma que se hará efectiva en cualquiera de nuestros centros de servicio autorizados en el país.

Si su aparato llegase a requerir de nuestro servicio de garantía, acuda al centro de servicio más cercano a su domicilio, de tener alguna duda por favor llame a nuestra **CENTRAL DE SERVICIO** al Tel.: 52 69 90 86, y en el interior del país LADA sin costo al 01 800 506 9200 en donde con gusto le indicaremos el centro de servicio autorizado más cercano a su domicilio.

PHILIPS MEXICANA S.A. de C.V. a través de sus centros de servicio autorizados **reparará y devolverá a usted su aparato en un plazo no mayor a 20 días hábiles,** contados a partir de la fecha de ingreso, impresa en la orden de servicio de cualquiera de nuestros centros de servicio autorizados.

La garantía de esta póliza cubre cualquier desperfecto o daño eventualmente ocasionado por los trabajos de reparación y/o traslado del aparato en el interior de nuestros centros de servicio autorizados.

Esta póliza sólo tendrá validez, si está debidamente requisitada, sellada por la casa vendedora, en caso de extravío de esta póliza, podrá hacer efectiva su garantía con la presentación de su factura de compra.

ESTA POLIZA NO SE HARA EFECTIVA EN LOS SIGUIENTES CASOS:

- Cuando el aparato sea utilizado en condiciones distintas a las normales.
- Cuando el aparato no haya sido operado de acuerdo con el instructivo de uso que se le acompaña.
- Cuando la causa de la falla o mal funcionamiento sea consecuencia de una reparación inadecuada o alteración producida por personas no autorizadas por PHILIPS MEXICANA S.A. de C.V.

PERIODOS DE GARANTIA

36 MESES. – Monitores para computadora.

12 MESES. – Televisores con y sin reproductor de video digital DVD, videocassetteras, reproductores de discos de video digital DVD, grabadores reproductores de disco de video digital DVD, grabadores reproductores de disco compacto, video proyectores (excepto la lámpara), cámaras de video, decodificadores de señal (IRD), televisores para hotel, sistemas de observación, televisores de proyección, teléfonos celulares, pagers, minisistemas de audio, microsistemas de audio, equipos modulares, sintonizadores, facsimils, LNB, antenas de recepción de satélite, DVD ROM, CDR ROM y CDRW ROM para computadora.

6 MESES. – Radiograbadoras con y sin reproductor de disco compacto, reproductores de cassette portátil, reproductores de disco compacto portátil, radio relojes, radios A.M./F.M., reproductores de audio digital MP3 (internet), auto esteros y teléfonos inalámbricos.

3 MESES. – Accesorios, controles remotos, bocinas, cinta para fax y para cámaras de videoconferencia.



PHILIPS

Philips Mexicana, S.A. de C.V.

Producto importado por:

Philips Mexicana, S.A. de C.V.

Av. La Palma No. 6

Col. San Fernando La Herradura

Huixquilucan, Edo. de México C. P. 52784

Tel. 52 69 90 00

Información General

Centro de Información al Consumidor

Lada 01 800 504 62 00

CENTRAL DE SERVICIO

Tel. 52 69 90 86

Lada 01 800 506 92 00

MODELO _____

Nº DE SERIE _____

La presente garantía contará a partir de:

DIA _____

MES _____

AÑO _____

En caso que en su producto se produzca alguna falla, acuda al centro de servicio más cercano a su domicilio (según listado de talleres), de tener alguna duda, por favor llame a nuestra CENTRAL DE SERVICIO, en donde con gusto le atenderemos.

Así mismo, cuando requiera refacciones y partes originales para su producto, acuda a los centros de servicio. Para hacer efectiva la garantía de su producto, es necesario que presente usted esta póliza debidamente requisitada, o de lo contrario, presentar su factura de compra.

CENTROS DE SERVICIO

Ciudad	EDO	Calle y N°	Colonia	C.P.	Nombre Comercial	Lada	Telefono	Fax	
Acapulco	GRO	Av. Revolucion N° 28	M. Aleman	39300	Servicio Electronico Profesional	744	83 32 96	-	S
Cd. Juarez	CHIH.	Rancho el Becerro 3011	Pradera Dorada	32610	Teleservicio Dominguez	656	18 21 28	18 21 28	S
Reynosa	TAMPS	Tiburcio Garza N° 401	Rodriguez	88630	Teleservicio Pepe	899	22 59 86	-	S
Chihuahua	CHIH.	Trasviña y Retes N° 3503-A	San Felipe	31240	Zener Electronica	614	14 01 16	14 33 51	S
Colima	COL.	Francisco I. Madero N° 426	Centro	28000	TV Antenas de Colima	312	403 01	403 01	S
Culiacan	SIN	Venustiano Carranza N° 140-A Nte.	Centro	80090	Estereo Voz	667	16 15 10	-	S
Guadalajara	JAL	Av. Vallarta N° 2250	Ladron de Guevara	44600	Leecom S.A. de C.V.	33	616 18 88 616 01 26	615 72 62	SR
Leon	GTO	Hernandez Alvarez N° 726	San Juan de Dios	37480	Tecnicos Especializados	477	70 26 99	15 58 64	S
Merida	YUC	Calle 70 N° 443 X 49 Depto. 8	Centro	97000	Servicentro	999	28 59 05	23 39 97	S
Mexicali	B.C.N.	Calzada Cuahutemoc N° 816-2	Cuahutemoc Norte	21200	Baja Electronics	686	61 98 08 61 98 08	-	S
Mexico	D.F.	Norte 1 D N° 4634	Defensores de la Republica	7780	Tecnologia y Servicio S.A. de C.V.	55	5368 30 21	5368 30 21	S
Mexico	D.F.	Calz. Vallejo N° 1045-03 Esq. Pte. 124	Nueva Vallejo	02300	Electronica Chyr S.A. de C.V.	55	567 19 92 567 22 56	56 79 62	SR
Mexico	D.F.	Nicolas San Juan N° 806, Esq. div. del Norte	Del Valle	03100	Centro de Servicio Electronico	55	536 71 03 536 25 75	5687 13 05	SR
Monterrey	N.L.	Juan Mendez N° 825 Nte.	Centro	64000	Monterrey Centro Electronico S.A.	81	375 16 17 400 54 03	375 34 86 400 54 04	SR
Morelia	MICH.	Lago de Patzcuaro N° 500-A	Ventura Puente	58020	Multiserv Profesionales de Zamora	443	12 03 17	-	S
Oaxaca	OAX	Huzares N° 207	Centro	68000	El Francistor S. de R.L. de C.V.	951	647 37	472 97	S
Pachuca	HGO	Pza. de las Americas Lote 28 Nucleo D	Valle de Sn Javier	42086	Frazare Electronica	771	14 15 81	18 86 72	S
Puebla	PUE	Av. 10 Pte. N° 2902-B	San Alejandro	72090	Selcom	222	48 77 64	31 63 77	SR
Queretaro	QRO	Bolivia 32	Lomas de Queretaro	76190	Electronica Zener	442	610 09	-	S
San Luis Potosi	S.L.P.	Dr. Salvador Nava N° 2755	Balcones del Valle	78280	Servicios Electronicos	444	534 07	-	S
Tampico	TAMPS	Laredo N° 105	Maihero	89060	Concesionario Philips Tampico	833	12 36 04	-	SR
Tijuana	B.C.N.	Av. Negrete 1613	Centro	22000	Sistemas Inalambricos de Comunicacion	666	85 23 22	85 23 22	S
Toluca	EDO MEX.	Calle Toluca N° 505	Sanchez	50040	Concesionario Philips Toluca	722	14 83 09	1703 20 21	S
Torreon	COAH	Mariano Lopez Ortiz N° 1126 Nte.	Centro	27000	Electronica Jomar	871	22 00 05	1702 19 76	S
Tuxtla Gutierrez	CHIS	10 Nte. Ote 153-A	Centro	29000	KC-Video	961	18 19 08	-	S
Veracruz	VER	Guerrero N° 1877 Entre Cortez y Canal	Centro	91700	Antza Comunicaciones	229	32 78 23 32 44 44	31 91 66	S
Villahermosa	TAB	Sanchez Marmol N° 206	Centro	86000	Tecnicentro	993	14 31 36	14 61 67	S

NOTA: Los Centros que tengan (S) solo proporcionan Servicio y los que tengan (SR) venden Refacciones y proporcionan Servicio.

English

Top and front panels (See [1])

- ① **VOLUME** – to adjust volume level
- ② **Source selector** : **CD, TUNER, TAPE/POWER OFF**
– selects CD, tuner or tape source of sound
– power off switch
- ③ **CD door**
- ④ **TUNING** – tunes to radio stations
- ⑤ **BAND** – selects waveband
- ⑥ **PREVIOUS, NEXT** ◀◀ , ▶▶
– skips or searches a passage/track backwards or forward
- ⑦ **PROG** – programs and reviews programmed track numbers
- ⑧ **CASSETTE RECORDER keys:**
⏸ – pauses playback or recording
■▲ – stops the tape;
– opens the cassette holder
◀◀ or **▶▶** – fast rewinds/ winds tape
▶ – starts playback
● – starts recording
- ⑨ **Cassette door**
- ⑩ **CD Display** – shows the CD functions
- ⑪ **PLAY/PAUSE** ▶⏸ - starts or pauses CD playback.
- ⑫ **STOP** ■ – stop playback;
– erases a CD program.

Back panel

- ⑬ **Telescopic antenna** - improves FM reception.

Note: AM band antenna is built into set (see Tuner reception)

Controls/Power Supply

- ⑭ **Battery door** - open to insert 6 x 1.5V **R-14/ UM2/ C-cells**.
- ⑮ **AC POWER/MAINS** - inlet for power cord.
- ⑯ **Voltage selector** – (inside the battery compartment, not all versions) adjust to match the local voltage 110/220V before plugging in the set.

CAUTION

Use of controls or adjustments or performance of procedures other than herein may result in hazardous radiation exposure or other unsafe operation.

Power Supply

Whenever convenient, use the mains supply cord if you want to conserve battery life. Make sure you remove the plug from the set and wall outlet before inserting batteries.

Batteries (not included)

- 1 Open the battery compartment and insert six batteries, type **R-14, UM-2** or **C-cells**, (preferably alkaline) with the correct polarity as indicated by the "+" and "-" symbols inside the compartment. (See [1])
- 2 Replace the compartment door, making sure the batteries are firmly and correctly in place. The set is now ready to operate.

Batteries contain chemical substances, so they should be disposed of properly.

Incorrect use of batteries can cause electrolyte leakage and will corrode the compartment or cause the batteries to burst:

Power Supply

- Do not mix battery types: e.g. alkaline with carbon zinc. Only use batteries of the same type for the set.
- When inserting new batteries, do not try to mix old batteries with the new ones.
- Remove the batteries if the set is not to be used for a long time.

Using AC Mains

- 1 Check if the power/mains voltage, **as shown on the type plate located on the bottom of the set**, corresponds to your local power supply. If it does not, consult your dealer or service center.
 - 2 Connect the power cord to the AC **POWER/MAINS** inlet and the wall socket. The mains lead is now connected and ready for use.
 - 3 To switch the set off completely, withdraw the power cord from the wall socket.
- Disconnect the mains lead from the wall socket to protect your set during heavy thunderstorms.

The type plate is located on the bottom of the set.

Switching POWER on/off:

Save energy

To avoid unnecessary energy consumption, always adjust the **source selector** to **TAPE/POWER OFF** after using the set. Also check that the tape deck keys are released.

General operation

- 1 To select your sound source adjust the **source selector** to : **CD, TUNER** or **TAPE/POWER OFF**.

Tuner/CD Player

- 2 Adjust the sound with the **VOLUME** control.
- 3 To switch off the set, adjust the source selector to **TAPE/POWER OFF** position and check the cassette keys are released.

Tuner reception

- 1 Adjust the **source selector** to **TUNER**.
- 2 Adjust **BAND** to select your desired waveband.
- 3 Turn **TUNING** to tune to a station.
 - For **FM** band signals, extend and turn the telescopic antenna for best reception. Reduce its length if the signal is too strong.
 - For **MW (AM)** band signals, the set uses a built-in antenna. Direct this antenna for best reception by turning the whole set.
- 4 To switch off the radio, adjust the source selector to **TAPE/POWER OFF** position and check the cassette keys are released.

CD Player

Display indication for CD functions:

- **⏸**: (See [2]) CD door open
- **- -**: (See [3]) reading disc contents / no disc/ error in CD operation or CD/ CD-R is blank or not finalized (see Troubleshooting)
- **During CD playback:** ▶ and current track number
- **▶⏸**: (See [4]) playback on pause
- **prog**: when CD program is active
- **F**: program memory full

Playing a CD

This CD player plays Audio Discs including CD-Recordables.

CD Player

- CD-RWs, MP3 CD-ROMs, CD-I, CDV, VCD, DVD or computer CDs are not possible for playback on this set.
- 1 Adjust the **source selector** to **CD**.
 - 2 Insert a CD/ CD-R with the printed side facing up and press the CD door gently close.
 - 3 Press **PLAY/PAUSE** **▶||** on the set to start playback.
 - 4 To pause playback press **PLAY/PAUSE** **▶||**. Press **PLAY/PAUSE** **▶||** again to resume play.
 - 5 To stop CD play, press **STOP** **■**.
 - 6 To switch off the set, adjust the source selector to **TAPE/POWER OFF** position and check the cassette keys are released.

Note : CD play will also stop when:

- you open the CD compartment;
- you select **TUNER** or **TAPE/POWER OFF** sound source;
- the CD has reached the end of playback.

Selecting a different track

During playback you can use **◀◀ / ▶▶** to select a particular track.

- If you have selected a track number in the stop or pause position, press **PLAY/PAUSE** **▶||** to start playback.

- Press **▶▶** once briefly for the next track, or press repeatedly until the desired track number appears in the display.
- Press **◀◀** once briefly to return to the beginning of a current track.
- Press **◀◀** repeatedly for a previous track.

Finding a passage within a track

- 1 During playback, press and hold down **◀◀ / ▶▶**.
 - The CD is played at high speed and low volume.
- 2 When you recognize the passage you want release **◀◀ / ▶▶**.
 - Normal playback resumes.

Note : When searching within a final track and you reach the end of the last track, the CD goes to stop mode.

Programming track numbers

You may store up to 32 tracks in the desired sequence. If you like, store any track more than once.

- 1 In the stop position, press **PROG** to activate programming.
→ Display shows **1** indicating the start of the program. **prog** flashes. (See [5])
- 2 Press **◀◀** or **▶▶** to select your desired track number.
- 3 Press **PROG** to store the desired track number.
→ Display shows you desired track number briefly followed by a number, **2** (up to **32** in sequence) indicating the next program location available. (See [6])
- 4 Repeat steps **2** to **3** to select and store all desired tracks in this way.
→ **FULL** indicates the program memory is full (when you have stored tracks on all **32** program locations).
- 5 To play your program, press **PLAY/PAUSE** **▶||**.

CD Player

To review a program

- In the stop position, press **PROG** repeatedly to see your stored track numbers.

Erasing a program

You can erase the contents of the memory by:
– selecting **TUNER** or **TAPE/POWER OFF** sound source;
– opening the CD door;
→ Display: **prog** disappears.

Cassette playback

- 1 Adjust the **source selector** to **TAPE/POWER OFF**.
- 2 Press **▶▲** to open the cassette holder and insert a cassette and close the deck.
- 3 Press **▶** to start playback.
- 4 To pause playback press **||** To resume, press the key again.
- 5 By pressing **◀◀** or **▶▶**, fast winding of the tape is possible in both directions. To stop fast winding, press **▶▲**.
- 6 To stop the tape, press **▶▲**.

The keys are automatically released at the end of a tape and the set switched off (unless PAUSE mode **||** has been activated.)

General information on recording

- Recording is permissible insofar as copyright or other rights of third parties are not infringed.
- For recording, use only NORMAL type cassettes (IEC type I) on which the tabs have not yet been broken. This deck is not suited for recording on CHROME (IEC II) or METAL (IEC IV) type cassettes.

Cassette Recorder

- The best recording level is set automatically. Altering the **VOLUME** will not affect the recording.
- To protect a tape from accidental erasure, break out the tabs. If you wish to record again, cover the tabs with a piece of adhesive tape.

Synchro Start CD recording

- 1 Select **CD** source.
- 2 Insert a CD and if desired, program track numbers.
- 3 Press **▶▲** to open the cassette holder. Insert a blank tape and close the deck.
- 4 Press **●** to start recording.
→ Playing of the CD program starts automatically from the beginning of the program. It is not necessary to start the CD player separately.
- 5 For brief interruptions press **||** To resume recording, press **||** again.
- 6 To stop recording, press **▶▲**.

Recording from the Radio

- 1 Adjust the **source selector** to **TUNER** to select your desired waveband.
- 2 Tune to the desired radio station (see **Tuner reception**).
- 3 Press **▶▲** to open the cassette holder. Insert a blank tape and close the deck.
- 4 Press **●** to start recording.
- 5 For brief interruptions press **||** To resume recording, press **||** again.
- 6 To stop recording, press **▶▲**.





Maintenance

Precautions & General Maintenance (See [7])

- Place the set on a hard and flat surface so that the system does not tilt.
- Do not expose the set, batteries, CDs to humidity, rain, sand or excessive heat caused by heating equipment or direct sunlight.
- Do not cover the set. Adequate ventilation with a minimum gap of 6 inches between the ventilation holes and surrounding surfaces is necessary to prevent heat build-up.
- The mechanical parts of the set contain self-lubricating bearings and must not be oiled or lubricated.
- To clean the set, use a dry cloth. Do not use any cleaning agents containing alcohol, ammonia, benzene or abrasives as these may harm the housing.

Tape deck maintenance (See [7])

To ensure quality recording and playback of the tape deck, clean parts (A), (B) and (C) as shown, once a month. Use a cotton bud slightly moistened with alcohol or a special head cleaning fluid to clean the deck.

- 1 Open the cassette holder by pressing .
- 2 Press  and clean the roller (C).
- 3 Press  and clean the heads (A), and the capstan (B).
- 4 After cleaning, press 
→ Cleaning of the heads can also be done by playing a cleaning cassette through once.

CD player and CD handling (See [7])

- Sudden changes in the surrounding temperature can cause condensation on the lens of your CD player. Playing a CD is then not possible. Do not attempt to clean the lens but leave the set in a warm environment until the moisture evaporates.
 - Always close the CD-tape door to avoid dust on the lens.
 - To clean the CD, wipe in a straight line from the center towards the edge using a soft, lint-free cloth. Do not use cleaning agents as they may damage the disc.
 - Never write on a CD or attach any stickers to it.
- If the CD player cannot read CDs correctly, use a cleaning CD to clean the lens before taking the set to repair.
 - The lens of the CD player should never be touched!

Troubleshooting

If a fault occurs, first check the points listed below before taking the set for repair.

If you are unable to remedy a problem by following these hints, consult your dealer or service centre.

WARNING: *Do not open the set as there is a risk of electric shock. Under no circumstances should you try to repair the set yourself, as this will invalidate the guarantee.*

Problem

- Possible cause
- Remedy

No sound /power

- Volume not adjusted
- Adjust the VOLUME
- Power cord not securely connected
- Connect the AC power cord properly
- Batteries dead/ incorrectly inserted
- Insert (fresh) batteries correctly

Display does not function properly/ No reaction to operation of any of the controls

- Electrostatic discharge
- Switch off and unplug the set. Reconnect after a few seconds

The CD skips tracks

- CD damaged or dirty
- Replace or clean CD
- Program is active
- Quit program mode

- - indication

- No CD inserted
- Insert a CD
- CD badly scratched or dirty
- Replace/ clean CD, see Maintenance
- Laser lens steamed up
- Wait until lens has cleared
- CD-R is blank or not finalized/ CD-RW inserted
- Use a finalized CD-R or suitable CD Audio disc only

Poor cassette sound quality

- Dust and dirt on the heads, etc.
- Clean deck parts, see Maintenance
- Use of incompatible cassette types (METAL or CHROME)
- Only use NORMAL (IEC I) for recording

Recording does not work

- Cassette tab(s) may be broken
- Apply adhesive tape over the missing tab space

Environmental information

All unnecessary packaging material has been omitted. The packaging can be easily separated into three materials: cardboard, polystyrene and plastic.

Your set consists of materials which can be recycled if disassembled by a specialized company. Please observe the local regulations regarding the disposal of packaging, dead batteries and old equipment.

English

Français

Español

中文

Meet Philips at the Internet
<http://www.audio.philips.com>

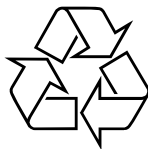

AZ 1004

**CLASS 1
LASER PRODUCT**



Printed in China