

L-402 Miniature Linear Stage

With DC or Stepper Motor



- Travel range 13 mm
- Unidirectional repeatability to 0.5 μm
- Velocity to 5 mm/s
- Load capacity to 1 kg
- Integrated reference point and limit switch

Standard-class linear stage

Miniature stage with very compact dimensions, only 22.5 mm width. Zero-backlash fine-threaded spindle. Linear crossed roller guides. Directly mountable XY and XYZ combinations. Optical reference point and limit switch.

Versions

- DC servo motor with rotary encoder on the motor shaft
- Stepper motor
- Versions with backlash-compensated ball screw on request
- Vacuum-compatible versions to 10^{-6} hPa on request

Fields of application

Micromanipulation, test systems, automation

Specifications

	L-402.10DD	L-402.10SD	Unit	Tolerance
Motion and positioning				
Travel range	13	13	mm	
Integrated sensor	Rotary encoder	–		
Design resolution	0.012	2.5 (full step)	μm	
Minimum incremental motion	1	0.5	μm	
Backlash	2	2	μm	
Unidirectional repeatability	1	0.5	μm	
Pitch	±175	±175	μrad	
Yaw	±125	±125		
Velocity	5	5	mm/s	max.
Mechanical properties				
Drive screw	Leadscrew	Leadscrew		
Spindle pitch	0.5	0.5	mm	
Load capacity	10	10	N	max.
Push/pull force	10	10	N	max.
Holding force	10	10	N	max.
Lateral force	5	5	N	max.
Drive properties				
Motor Type	DC motor	2-phase stepper motor*		
Operating voltage	0 to ±12		V	
Current consumption	0.46**		A	
Reference and limit switches	optical	optical		
Miscellaneous				
Operating temperature range	-20 to 65	-20 to 65	°C	
Material	Aluminum, anodized, stainless steel	Aluminum, anodized, stainless steel		
Mass	0.2	0.15	kg	
Cable length	0.135	0.25		±10

Connector	HD D-Sub 26, incl. encoder driver	HD D-Sub 26		
Recommended controller/driver	C-863 (single axis) C-884 (up to 4 axes)	C-663 (single axis)		

* 24 V chopper voltage, max. 0.25 A/phase; 200 full steps/rev

** thermally limited average current

All cables required for operation with the recommended controller are included in the scope of delivery. 3m extension cable included.

Ask about custom designs!

Drawings and Images

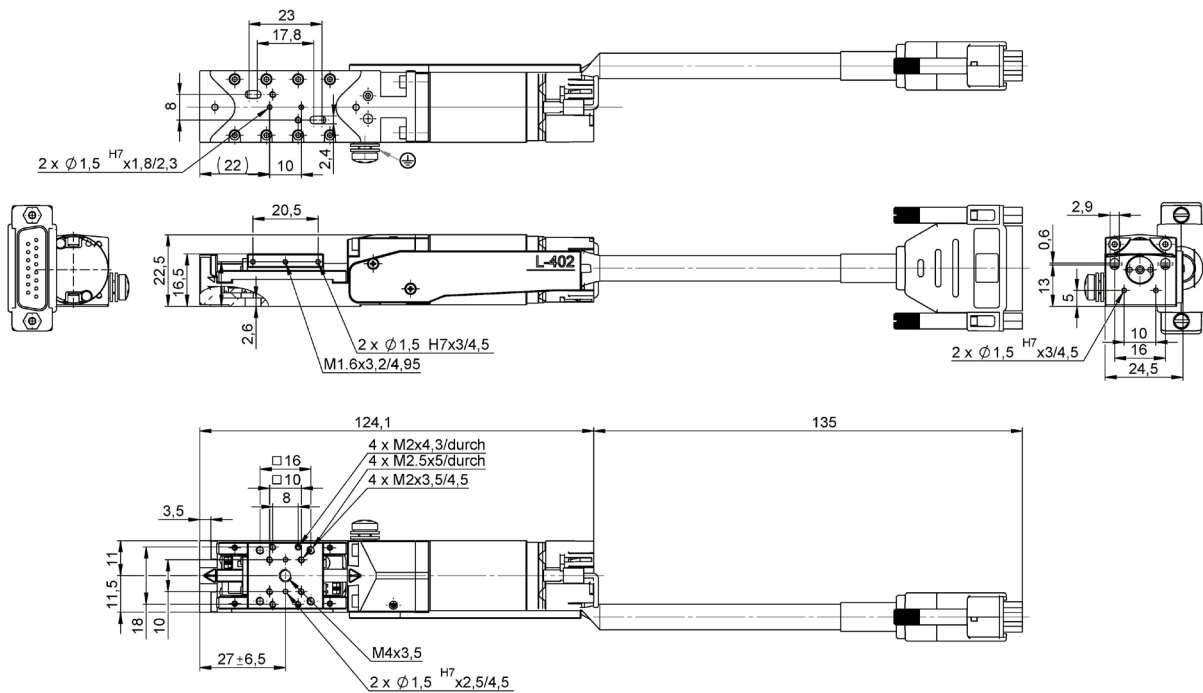

L-402.10DD, dimensions in mm

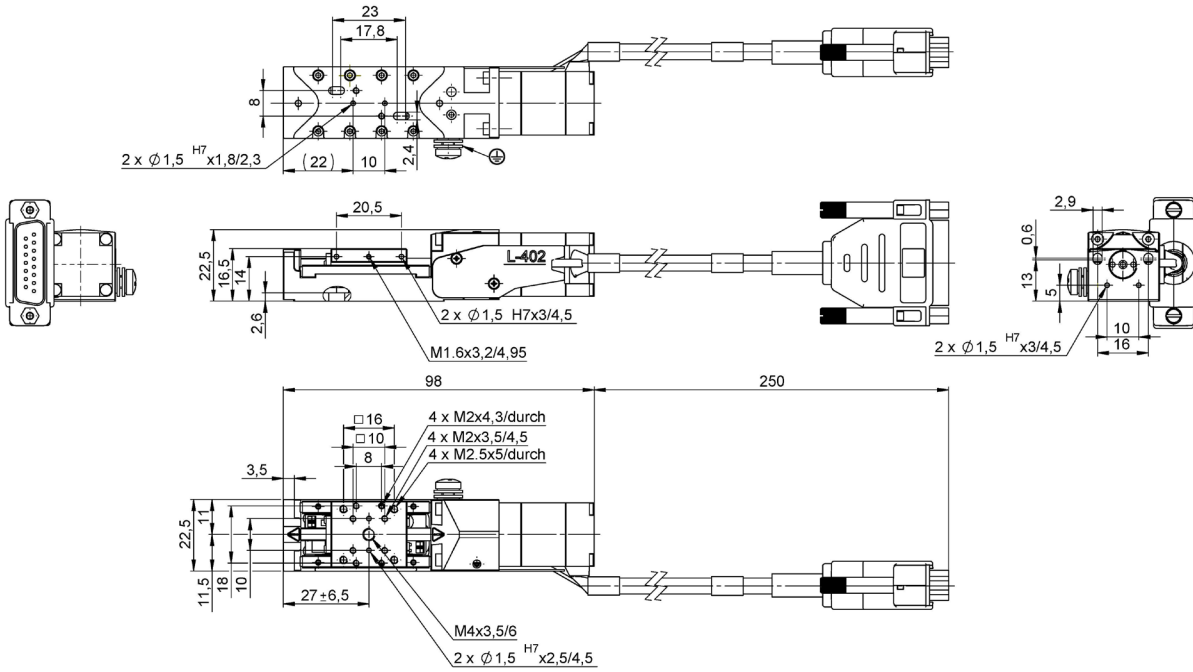

L-402.10SD, dimensions in mm



L-402.10DD with DC motor

Ordering Information

L-402.10DD

Miniature Linear Stage, 22 mm Width, DC Motor, 13 mm Travel Range

L-402.10SD

Miniature Linear Stage, 22 mm Width, Stepper Motor, 13 mm Travel Range