

N-216 NEXLINE® Piezo Stepping High-Load Actuator

Contents

1	General Information.....	3
1.1	Legal Information	3
1.1	Symbols and Typographic Conventions	3
1.2	Figures.....	4
1.3	Other Applicable Documents	4
1.4	Intended Use	4
2	Product Description	5
2.1	Features and Applications.....	5
2.2	Model Overview	6
2.3	Product View.....	7
2.3.1	Product Details	7
2.3.2	Product Labeling	8
2.4	Scope of Delivery	9
2.5	Suitable Controllers.....	9
2.6	Only N-216.1A1 / N-216.2A1: Technical Features for Closed-Loop Operation	9
2.6.1	Linear Encoder	9
2.6.2	Reference Point Switch	9
3	Unpacking	9
4	Installation	10
4.1	Mounting the N-216 onto a Surface	10
4.1.1	Options.....	11
4.1.2	Mounting the Mounting Flange A onto the Actuator	12
4.1.3	Mounting the Mounting Flange B onto the Actuator	13
4.1.4	Mounting the N-216 onto a Surface	14
4.2	Connecting the N-216 to the Protective Earth Conductor	15
4.3	Affixing Load to the N-216.....	17
4.4	Connecting the N-216 to the Controller	19

5	Start-Up and Operation	20
5.1	General Notes on Start-Up and Operation	20
5.2	Operating the N-216	22
5.3	Discharging the N-216	23
6	Maintenance.....	23
6.1	General Notes on Maintenance.....	23
6.2	Cleaning the N-216.....	23
7	Troubleshooting	24
8	Customer Service.....	24
9	Technical Data	25
9.1	Specifications.....	25
9.1.1	Data Table.....	25
9.1.2	Ambient Conditions and Classifications.....	26
9.2	Maximum Ratings	26
9.3	Mechanical Load Capacity	27
9.4	Dimensions	29
9.4.1	N-216 Actuator	29
9.4.2	N216E0006 Mounting Flange A.....	30
9.4.3	N216E0008 Mounting Flange B.....	30
9.5	Pin Assignment (D-Sub 25, m).....	31
9.5.1	N-216.101 / N-216.201	31
9.5.2	N-216.1A1 / N-216.2A1	32
10	Old Equipment Disposal.....	33
11	EU Declaration of Conformity	33

1 General Information

1.1 Legal Information

Physik Instrumente (PI) GmbH & Co. KG is the owner of the following trademarks: PI[®], PIC[®], PICMA[®], PILine[®], PIFOC[®], PiezoWalk[®], PIMag[®], NEXACT[®], NEXLINE[®], NanoCube[®], NanoAutomation[®], Picoactuator[®], PInano[®]

PI owns the following patents or patent applications for the technology field Piezo Stepping Drive (PiezoWalk[®], NEXACT[®], NEXLINE[®]):

DE10148267B4, EP1267478B1, EP2209202B1, EP2209203B1, US6800984B2

© 2013-2017 Physik Instrumente (PI) GmbH & Co. KG, Karlsruhe, Germany. The text, photographs and drawings in this manual are protected by copyright. With regard thereto, Physik Instrumente (PI) GmbH & Co. KG retains all the rights. Use of said text, photographs and drawings is permitted only in part and only upon citation of the source.

Original instructions

First printing: 20 July 2017

Document number: N216T0013, MMA, version 1.1.0

Subject to change without notice. This document is superseded by any new release.

1.1 Symbols and Typographic Conventions

The following symbols and typographic conventions are used in this document:

CAUTION



Dangerous situation

If not avoided, the dangerous situation will result in minor injury.



- Actions to take to avoid the situation.



NOTICE



Dangerous situation

If not avoided, the dangerous situation will result in damage to the equipment.

- Actions to take to avoid the situation.

INFORMATION

- Information for easier handling, tricks, tips, etc.

Symbol / Label	Meaning
1. 2.	Action consisting of several steps whose sequential order must be observed
➤	Action consisting of one or several steps whose sequential order is irrelevant
▪	List item
p. 5	Cross-reference to page 5
RS-232	Labeling of an operating element on the product (example: socket of the RS-232 interface)
	Warning signs affixed to the product that refer to detailed information in this manual

1.2 Figures

For better understandability, the colors, proportions and degree of detail in illustrations can deviate from the actual circumstances. Photographic illustrations may also differ and must not be seen as guaranteed properties.

1.3 Other Applicable Documents

The devices and software tools which are mentioned in this documentation are described in their own manuals.

Product	Document
E-712 Digital Piezo Controller	PZ195E User Manual
PIMikroMove	SM148E Software Manual

For customer-specific models, additional Technical Notes may apply.

1.4 Intended Use

The N-216 is a laboratory device as defined by DIN EN 61010-1. It is intended to be used in interior spaces and in an environment which is free of dirt, oil, and lubricants.

Based on its design and realization, the N-216 is intended for single-axis positioning, adjusting and shifting of loads at various velocities.

The intended use of the N-216 is **only** possible when installed and in connection with a suitable controller (p. 9). The controller is not included in the scope of delivery of the N-216.

In the ideal application case, the linear actuator is operated **quasi-statically**. In quasi-static operation, the load is mainly kept at a particular position and only temporarily positioned (stepping mode).

2 Product Description

2.1 Features and Applications

- Travel range 20 mm
- Holding force up to 800 N
- Resolution to 0.03 nm Open-Loop, 5 nm Closed-Loop
- PiezoWalk[®] principle
- Self-locking, thus no holding currents and no heat generation at rest
- Non-magnetic function principle
- Can also be used in environments with:
 - Clean room requirements
 - Strong magnetic fields
 - Strong UV radiation
 - Vacuum (modified products up to 0.1 hPa, on request)

The N-216 NEXLINE[®] linear actuator is a compact drive for Nano positioning technology. The feed is generated by coordinated shearing and clamping motions of strongly preloaded piezo elements that are coupled to a rod (PiezoWalk[®] principle). In this way, NEXLINE[®] drives combine relatively long travel ranges with the nanometer precision of piezo actuators.

Models N-216.1A1 and N-216.2A1 are equipped with a linear encoder for direct measurement of rod positions. The resolution here is 5 nm over the entire travel range (closed-loop operation).

In highly dynamic analog operation, position resolutions up to 30 pm can be achieved (open-loop operation).

The linear actuator supports the following modes of operation for positioning a load:

Operating Mode	Advantages
Full step mode	<ul style="list-style-type: none">▪ Long travel ranges▪ High velocity▪ High dynamic forces
Nanostepping mode	<ul style="list-style-type: none">▪ Long travel ranges▪ Low vibration▪ Uniformity of motion
Analog mode	<ul style="list-style-type: none">▪ Travel ranges in the μm range▪ High dynamics▪ High resolution

- Further details on the operating modes are found in the manual of the controller used.

2.2 Model Overview

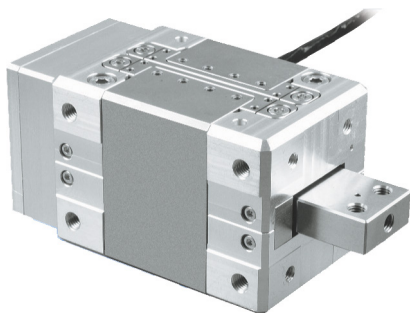

Figure 1: View of the N-216; applies for all models

Four standard versions of the N-216 NEXLINE[®] linear actuator are available. They differ regarding the presence of an integrated position sensor (linear encoder) and in the drive force.

Model	Properties
N-216.101	NEXLINE [®] Piezo Stepping High-Load Actuator, 20 mm, 300 N, Open-Loop
N-216.1A1	NEXLINE [®] Piezo Stepping High-Load Actuator, 20 mm, 300 N, Linear Encoder, 5 nm Resolution
N-216.201	NEXLINE [®] Piezo Stepping High-Load Actuator, 20 mm, 600 N, Open-Loop
N-216.2A1	NEXLINE [®] Piezo Stepping High-Load Actuator, 20 mm, 600 N, Linear Encoder, 5 nm Resolution

- For further technical data, see the specifications (p. 25).

PI also produces custom designs upon request. Custom designs can differ from the described standard products in respect to dimensions, characteristics or other technical data.

- If necessary, contact our customer service department (p. 24) directly.

2.3 Product View

2.3.1 Product Details

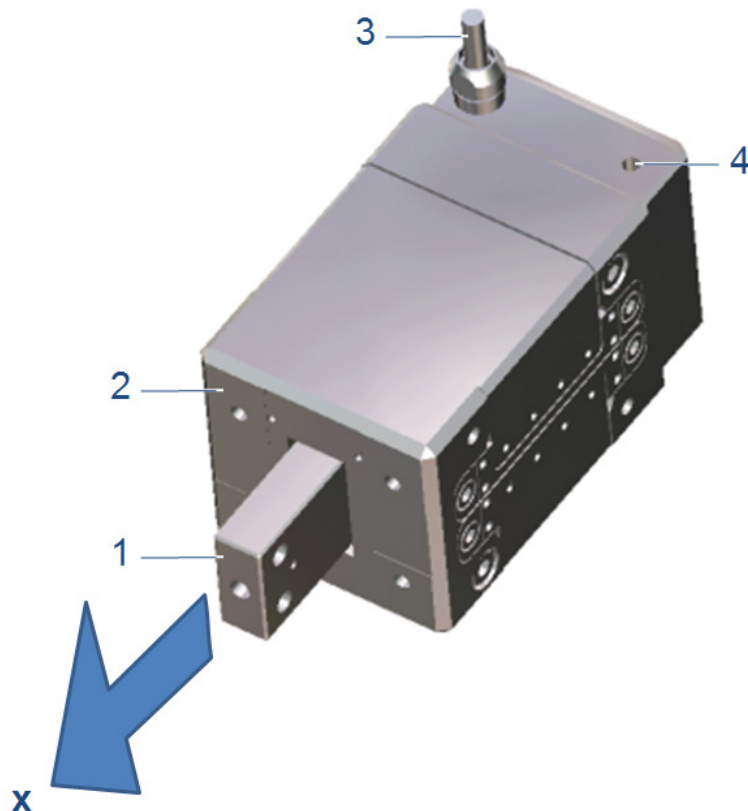
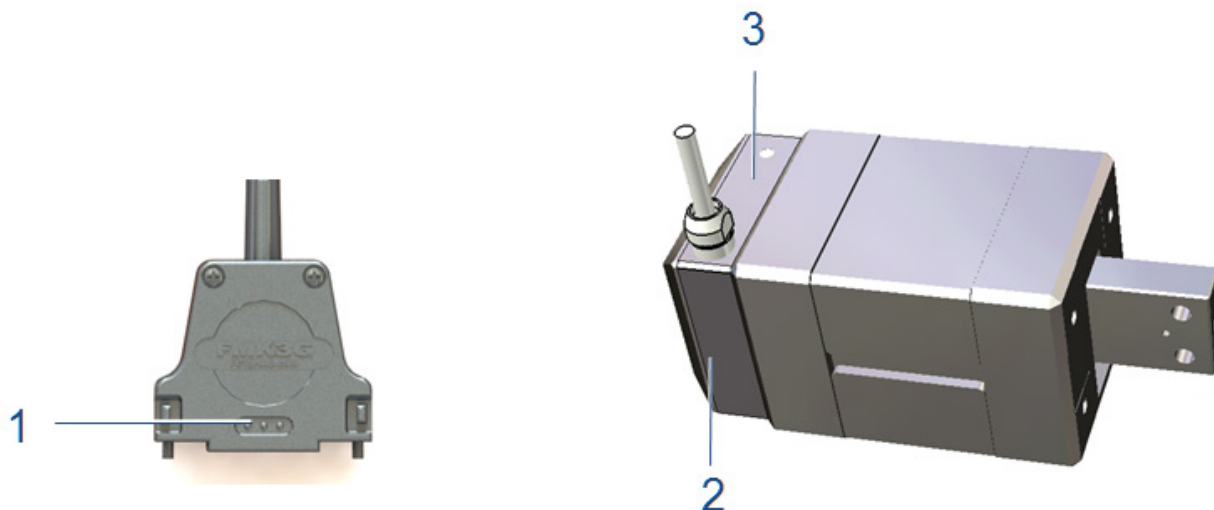







Figure 2: Position of important elements

- 1 Rod
- 2 Actuator case
- 3 Connection cable
- 4 Protective earth connection
- x Positive direction of rod motion

2.3.2 Product Labeling



Position	Label	Description
1		Warning symbol "High Voltage"
2	N-216.1A1	Product name
2		Manufacturer's logo
2	WWW.PI.WS	Manufacturer's address (website)
2	Country of origin: Germany	Country of origin
2	114007694	Serial number (example), individual for each N-422 Meaning of the places (counting from left): 1 = internal information, 2 and 3 = manufacturing year, 4 to 9 = consecutive numbers
2		Warning sign "Observe manual!"
2		CE conformity mark
2		Old equipment disposal (p. 33)
3		Protective earth symbol (indicating the location of the protective earth connection)

2.4 Scope of Delivery

The N-216 is delivered with the following components.

Order Number	Component
N-216.xx1	Linear actuator according to order
N216E0006	Mounting flange A
N216E0008	Mounting flange B
000036450	M4 screw set for protective earth connection
2175	Mounting screws DIN EN ISO 4762-M4x8-A2 (4 pcs.)
2176	Mounting screws DIN 7984-M5x10-A4-70 (4 pcs.)
N216T0013	Technical Note (this document) in printed form
	Packaging materials

2.5 Suitable Controllers

Controller	Description
E-712.1AM	Modular system with piezo amplifier module for NEXLINE® drives

2.6 Only N-216.1A1 / N-216.2A1: Technical Features for Closed-Loop Operation

2.6.1 Linear Encoder

The linear actuator is equipped with an optical linear encoder. For the encoder resolution, refer to the table in the "Specifications" (p. 25) section.

Optical linear encoders measure the actual position directly (direct metrology). Therefore, errors occurring in the drivetrain, such as nonlinearity, backlash or elastic deformation, cannot influence the measurement of the position.

2.6.2 Reference Point Switch

The linear actuator is equipped with a direction-sensing reference point switch that is located approximately in the middle of the travel range. This sensor transmits a TTL signal that indicates whether the linear actuator is on the positive or negative side of the reference point switch.

The commands that use the reference signal are described in the user manual of the controller and/or in the corresponding software manuals.

3 Unpacking

1. Unpack the N-216 with care.
2. Compare the contents against the items covered by the contract and against the packing list.
3. Inspect the contents for signs of damage. If parts are missing or you notice signs of damage, contact PI immediately.
4. Keep all packaging materials in case the product needs to be returned.

4 Installation

4.1 Mounting the N-216 onto a Surface

INFORMATION

In order to achieve an optimum repeatability, the linear actuator must be mounted without backlash.

- During mounting, ensure that the connection between the linear actuator and the installation environment is faultless.
-

4.1.1 Options

Depending on the environment of your application, the following options may be applicable for mounting the actuator on a surface:

Option	Illustration (Example)		Preparation of the actuator for surface mounting
	Spatial view	Sectional view (Note the highlighted screws)	
Direct mounting (Illustrated example: "bottom" side*; for details see paragraph 4.1.4)			None
Mounting with mounting flange A applied			Mounting the mounting flange A on the actuator (see paragraph 4.1.2)
Mounting with mounting flange B applied			Mounting the mounting flange B on the actuator (see paragraph 4.1.3)

* Using the threaded holes in the "rod side" of the actuator case is also applicable, see paragraph 4.1.4.

4.1.2 Mounting the Mounting Flange A onto the Actuator

Tools and accessories

- Mounting flange A (N216E0006)
- Four M5x10 cylinder head screws (DIN 7984), included in the delivery
- Hexagonal key AF 4 (or compliant screwdriver)

Requirements

- The linear actuator is not connected to the controller.

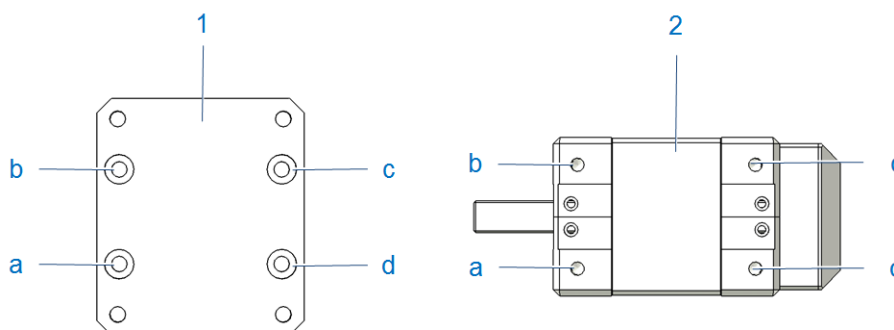

Figure 3: Used mounting holes for flange A mounting

1 Mounting flange A with
a - d) mounting holes with counter bores

2 Actuator with
a - d) threaded mounting holes

Holes that overlap during attachment are marked with the same letters.

1. Position the mounting holes in the mounting plate over the corresponding holes in the actuator (see figure above). Note that the counter bores must be visible (face-up).
2. Completely screw in the cylinder head screws at all mounting holes (see figure below).

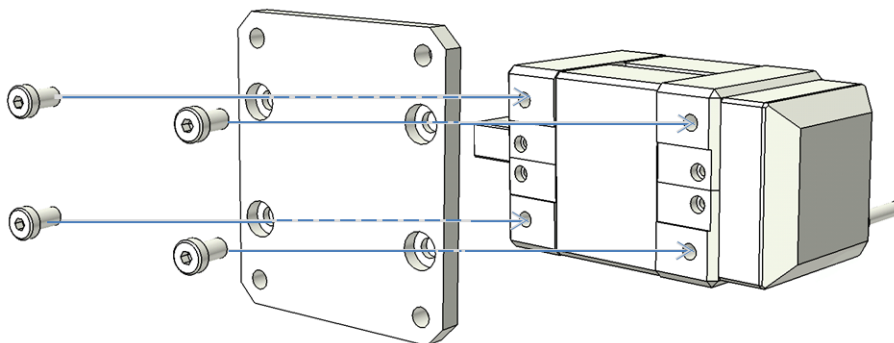

Figure 4: Mounting the mounting flange A, exploded view

3. Check that the linear actuator fits onto the surface without backlash.

4.1.3 Mounting the Mounting Flange B onto the Actuator

Tools and accessories

- Mounting flange B (N216E0008)
- Four M4x8 (ISO 4762) cylinder head screws, included in the delivery
- Hexagonal key AF 3 (or compliant screwdriver)

Requirements

- The linear actuator is not connected to the controller.

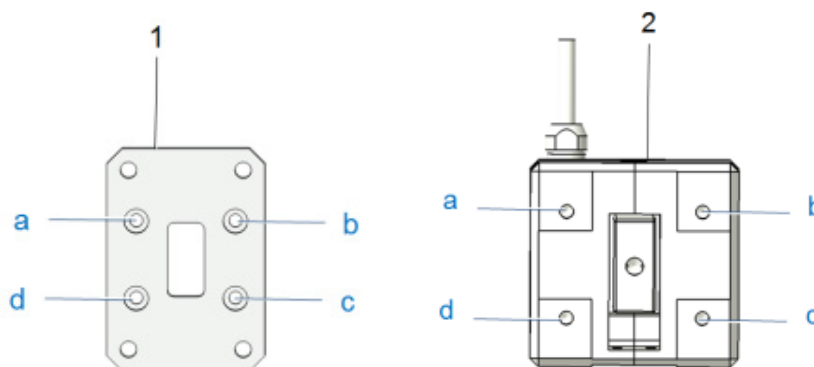

Figure 5: Used mounting holes for flange B mounting

1 Mounting flange B with
a - d) mounting holes with counter bores

2 Actuator with
a - d) threaded mounting holes

Holes that overlap during attachment are marked with the same letters.

1. Position the mounting holes in the mounting plate over the corresponding holes in the actuator (see figure above). Note that the counter bores must be visible (face-up).
2. Completely screw in the cylinder head screws at all mounting holes (see figure below).

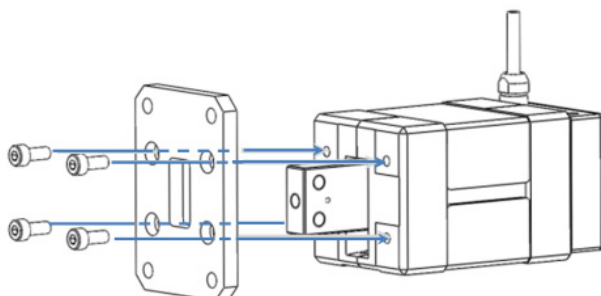

Figure 6: Mounting the mounting flange B, exploded view

3. Check that the linear actuator fits onto the surface without backlash.

4.1.4 Mounting the N-216 onto a Surface

Depending on the selected mounting option, the following holes are used for mounting the N-216 onto a surface (refer to the arrows in the illustrations):

Mounting option	Positions of the used mounting holes
<p>Direct mounting (Use positions indicated either by black or white arrows)</p>	
<p>Mounting with mounting flange A applied</p>	
<p>Mounting with mounting flange B applied</p>	

Tools and accessories

INFORMATION

Depending on the thickness of the surface, the screws included in the delivery may suit for direct mounting.

- Four screws M5 (Exception: M4 screws for direct mounting on the rod side of the actuator case); length adapted on the depth of the threaded holes in the surface
- Suitable screwdriver or hexagonal key (e.g. AF 4 for mounting M5 cylinder head screws)

Requirements

- You have provided a surface with four threaded holes with distances corresponding to the dedicated holes in the used mounting flange or of the N-216, depending on the selected mounting option (see chapter 9.4 *Dimensions*).
- The linear actuator is not connected to the controller.

Mounting the N-216 on a surface

1. Depending on the mounting option, position the mounting holes either in the actuator or in the mounting plate of the linear actuator (see figure) over the corresponding holes in the surface.
2. Completely screw in the cylinder head screws at all used mounting holes.
3. Check that the linear actuator fits onto the surface without backlash.

4.2 Connecting the N-216 to the Protective Earth Conductor

INFORMATION

- Observe the applicable standards for mounting the protective earth conductor.

INFORMATION

The hole for the protective earth connection is marked on the product (p. 8).

Tools and accessories

- Suitable protective earth conductor: with cross-section $\geq 0.75 \text{ mm}^2$, resistance $< 0.1 \Omega$ at 25 A, insulation green/yellow
- M4 screw set (included in the scope of delivery of the linear actuator)
- Philips-head screwdriver (PH 2)

Connecting the N-216 to the protective earth conductor

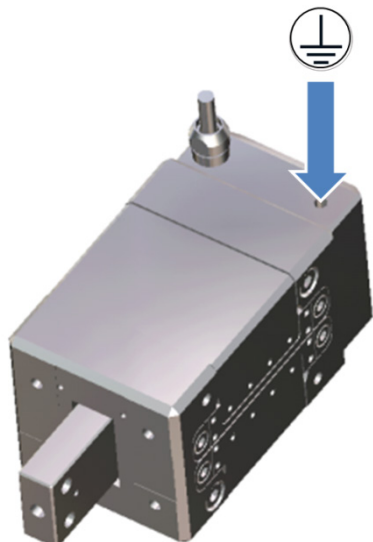

Figure 7: Position of the protective earth connector

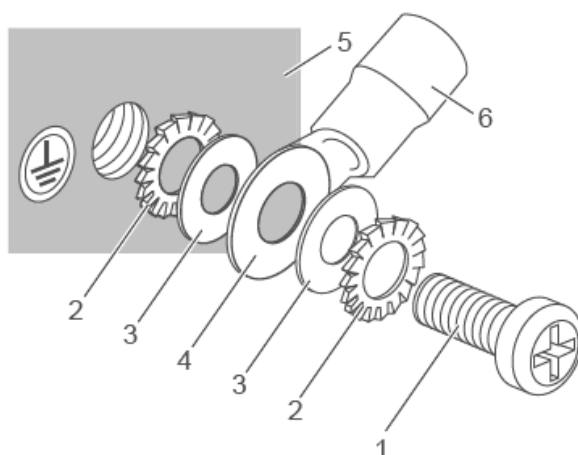

Figure 8: Mounting of protective earth connection (schematic)

1. M4 screw
2. Toothed washer
3. Flat washer
4. Cable lug
5. Linear actuator case with protective earth connection (M4 threaded hole) and protective earth conductor symbol
6. Protective earth conductor

1. If necessary, fasten a suitable cable lug to the protective earth conductor.
2. Remove the screw, the toothed washers and flat washers from the package of the screw set.

3. As shown in the above figure: fasten one flat washer and one toothed washer each above and below the protective earth conductor or its cable lug with the screw on the protective earth connection of the linear actuator (position of the protective earth connection on the linear actuator: see figure above).
4. Tighten the screw with a torque of 1.2 Nm to 1.5 Nm.
5. Make sure that the protective earth conductor of the linear actuator is properly connected with the existing protective earth system within your application at all times.

4.3 Affixing Load to the N-216

NOTICE



Impermissibly high load on the linear actuator

Impermissibly high loads inhibit the motion of the rod and can damage or destroy the linear actuator.

- With respect to mass and fastening type of the load, observe the maximum permissible active and passive forces and the resulting torques that are allowed to act on the rod according to the specification (p. 25).

INFORMATION

In order to achieve an optimum repeatability, the load must be mounted without backlash.

- During mounting, ensure that the connection between the linear actuator and the load is faultless.

Requirements

- You have properly fastened the linear actuator according to the corresponding instructions (p. 10).
- The linear actuator is **not** connected to the controller.

Tools and accessories

- M5 fastening screw with suitable length (depth of the threaded hole: 8 mm; further dimensions see p. 29).
- If necessary: M5 spring washer(s) or flat washer(s)
- Open-end wrench, AF 10 and / or AF 22
- Suitable screwdriver, hexagonal key or open-end wrench for the fastening screw(s)

Affixing load to the N-216

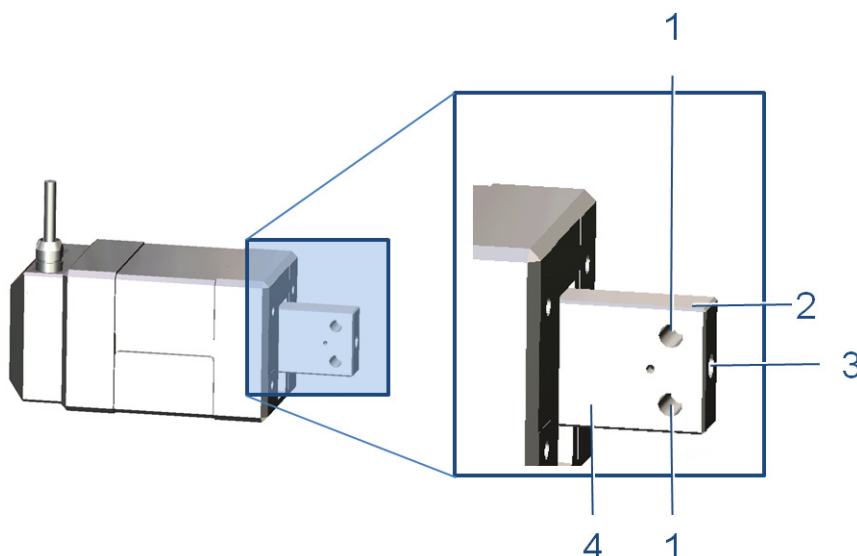

Figure 9: Relevant components of the rod for affixing the load

- 1 Tapped through hole M5 for affixing the load
 - 2 Narrow plane of the rod *
 - 3 Tapped blind hole M5 (depth 8 mm) for affixing the load
 - 4 Broad plane of the rod *
- * A corresponding further (parallel) plane is present, but not visible in this view

1. Fix the rod by applying the open-end wrench to the planes of the rod.
Options:
 - Embrace the narrow planes of the rod with the open-end wrench AF 22
 - Embrace the broad planes of the rod with the open-end wrench AF 10.
2. Affix the load on the hole(s) in the rod of the linear actuator with the fastening screw(s) and, if necessary, attached spacers, safety washers or spring washers: Screw in the screw(s) until you feel a resistance and tighten the screw(s) with a torque of 3.5 Nm to 5 Nm.
3. Check whether a backlash-free connection is ensured at all times.

4.4 Connecting the N-216 to the Controller

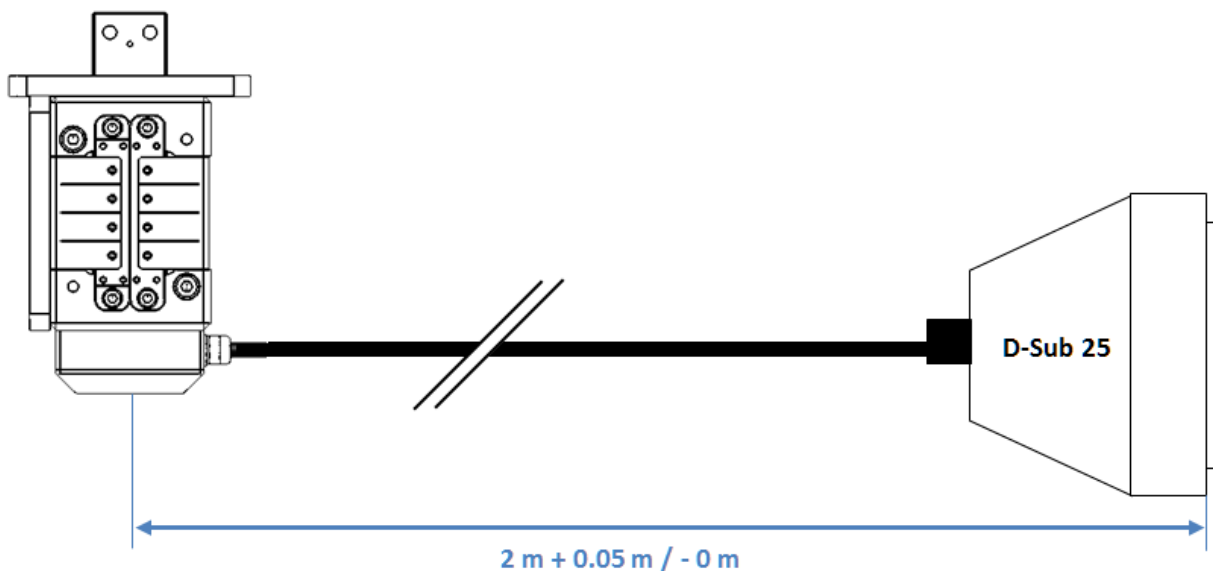

Figure 10: Cable diagram

Requirements

- You have properly mounted the linear actuator (p. 10) and connected the protective earth conductor (p. 15).
- You have installed a suitable controller (p. 9).
- You have read and understood the user manual of the controller.

Connecting the N-216 to the controller

1. Connect the connector of the linear actuator with the corresponding socket of the controller (see user manual of the controller).
2. Secure the connection with the integrated screws against being accidentally pulled out.
3. Eliminate or label resulting danger areas in accordance with the valid regulations and recommendations.

5 Start-Up and Operation

5.1 General Notes on Start-Up and Operation

CAUTION



Risk of electric shock if the protective earth conductor is not connected!

If a protective earth conductor is not or not properly connected, dangerous touch voltages can occur on the N-216 in the case of malfunction or failure of the system. If touch voltages exist, touching the N-216 can result in minor injuries due to electric shock.

- Connect the N-216 to a protective earth conductor before start-up (p. 15).
- Do **not** remove the protective earth conductor during operation.
- If the protective earth conductor has to be removed temporarily (e. g. in the case of modifications), reconnect the N-216 to the protective earth conductor before starting it up again.

CAUTION



Dangerous voltage and residual charge on piezo actuators!

The N-216 is driven by piezo actuators. Temperature changes and compressive stresses can induce charges in piezo actuators. After being disconnected from the electronics, piezo actuators can also stay charged for several hours. Touching or short-circuiting the contacts in the connector of the N-216 can lead to minor injuries. In addition, the piezo actuators can be destroyed by an abrupt contraction.

- Do **not** open the N-216.
- Do **not** touch the contacts in the connector of the linear actuator.
- Secure the connector of the linear actuator with screws against being pulled out of the controller.

If you want to pull out the connector of the linear actuator:

- Do **not** pull out the connector from the controller during operation.
- Discharge the linear actuator **before pulling out the connector (p. 23)**.
- If possible: Switch off the controller and wait at least 10 seconds **before pulling out the connector**.

CAUTION



Burning from hot surface!

The surface of the actuator can become hot during operation. Touching the actuator can cause slight injuries from burning.

- Cool the actuator e.g. with protective air so that the temperature of its surface does **not** exceed 65 °C.
- If sufficient cooling is not possible: Make sure that the hot actuator **cannot** be touched.
- When sufficient cooling and protection against contact are not possible: Mark the danger zone according to the legal regulations.
- The actuator must be operated **only after** completed installation.

NOTICE



Destruction of the drive at the end position due to continuous high voltage!

High voltages that are applied to the piezo actuators can damage the NexLine® drive.

If it is necessary to hold a constant position for one hour or longer:

- After reaching the target position, set the voltage at the drive to 0 V either manually or with the "RNP" command.
- Afterwards, make sure that the desired operating mode (open loop / closed loop) is maintained.

NOTICE



Heating up of the N-216 during operation!

The heat produced during constant or dynamic operation of the N-216 can affect your application.

- Install the N-216 so that your application is not affected by the dissipating heat.

NOTICE



Uncontrolled oscillation!

Your application and the N-216 can be damaged by uncontrolled oscillations. Uncontrolled oscillations can be identified by the fact that the linear actuator approaches the target position too slowly or too fast or does not keep it stable (servo jitter).

If uncontrolled oscillations occur during the operation of the N-216:

- Immediately switch off the servo-control system of the affected axis.
- Check the settings of the servo control parameters.

NOTICE



Increased friction due to lateral forces on the rod.

Lateral forces that act on the rod of the linear actuator increase the friction between the rod and other drive components. Increased friction inhibits the motion of the rod and increases the wear of the drive components.

- Avoid lateral forces on the rod of the linear actuator.

INFORMATION

For sending commands to the linear actuator, the outward motion of the rod is defined as positive direction of motion.

INFORMATION

In the ideal application case, the linear actuator is operated quasi-statically. In quasi-static operation, the load is mainly kept at a particular position and only temporarily positioned (stepping mode).

For N-216.1A1 / N-216.2A1, the following also applies:

INFORMATION

The repeatability of the positioning is only ensured when the reference point switch is always approached from the same side. Recommended controllers from PI fulfill this requirement with their automatic direction detection for reference moves to the reference switch.

5.2 Operating the N-216

Requirements

- You have read and understood the user manual of the controller.
- You have read and understood the user manual of the PC software.
- You have properly mounted the linear actuator (p. 10), connected the protective earth conductor (p. 15) and the load (p. 17).
- The controller and the required PC software have been installed. All connections with the controller have been established (see user manual of the controller).

Operating the N-216

- Follow the instructions in the manual of the used controller for start-up and operation of the N-216.

5.3 Discharging the N-216

The N-216 must be discharged in the following cases:

- When the N-216 is not used but the controller remains switched on to ensure temperature stability
- Before demounting (e.g. before cleaning and transport of the N-216 and for modifications of the application)
- Before pulling out the connector of the N-216

Discharging the N-216 that is connected to the controller

If you are working in closed-loop operation:

1. Switch off the servo mode on the controller.
2. Set the piezo voltage to 0 V on the controller.

If you are working in open-loop operation:

- Set the piezo voltage to 0 V on the controller.

Discharging the N-216 that is not connected to the controller

- Connect the linear actuator to the switched-off controller from PI.

6 Maintenance

6.1 General Notes on Maintenance

NOTICE



Damage due to improper maintenance!

The linear actuator can become misaligned as a result of improper maintenance. The specifications can change as a result (p. 25).

- Do not loosen screws that are part of the actuator case.

6.2 Cleaning the N-216

Requirements

- You have disconnected the linear actuator from the controller.

Cleaning the linear actuator

- When necessary, clean the linear actuator surface with a towel lightly dampened with a mild cleanser or disinfectant.
- Do **not** apply ultrasonic cleaning.

7 Troubleshooting

Problem	Possible Causes	Solution
Target position is approached too slowly or with overshoot	<ul style="list-style-type: none"> ▪ Servo-control parameters are not optimally set ▪ Large changes in the load 	<ol style="list-style-type: none"> 1. Switch off the servo-control system immediately. 2. Check the settings of the servo-control parameters. 3. If necessary, correct the settings of the servo-control parameters.
Target position is not kept stable		
Uncontrolled oscillations of the N-216		
Increased wear	Excessive lateral forces on the rod	<ul style="list-style-type: none"> ➤ Avoid lateral forces on the rod of the N-216.
Reduced accuracy		
No or limited motion	<ul style="list-style-type: none"> ▪ Excessive load ▪ Excessive counterforces in the direction of motion 	<ul style="list-style-type: none"> ➤ Reduce the load (see "Mechanical Load Capacity" (p. 27)). <p>In the case of vertical mounting:</p> <ul style="list-style-type: none"> ➤ Ensure gravity compensation so that the maximum load (p. 27) is not exceeded.

If the problem that occurred with your system is not listed in the table above or cannot be solved as described, contact our customer service department (p. 24).

8 Customer Service

For inquiries and orders, contact your PI sales engineer or send us an e-mail (<mailto:info@pi.ws>).

If you have questions concerning your system, have the following information ready:

- Product codes and serial numbers of all products in the system
- Firmware version of the controller (if present)
- Version of the driver or the software (if present)
- Operating system on the PC (if present)

9 Technical Data

9.1 Specifications

9.1.1 Data Table

Model	N-216.101 / N-216.1A1	N-216.201 / N-216.2A1	Tolerance
Active axes	X	X	
Motion and positioning			
Displacement	20 mm	20 mm	
Step size (in step mode)	10 nm to 10 µm	10 nm to 10 µm	
Travel range in analog mode	±3 µm	±3 µm	
Integrated sensor	N-216.101: none, N-216.1A1: linear encoder	N-216.201: none, N-216.2A1: linear encoder	
Open-loop resolution	0.03 nm	0.03 nm	typ.
Closed-loop resolution	- / 5 nm (N-216.1A1)	- / 5 nm (N-216.2A1)	
Max. velocity, (10% duty cycle, full step mode)	1.0 mm/s	1.0 mm/s	
Max. velocity, (100% duty cycle, full step mode)	0.6 mm/s	0.6 mm/s	
Max. velocity, (100% duty cycle, nanostepping mode)	0.4 mm/s	0.4 mm/s	
Mechanical properties			
Drive force (active)*	300 N	600 N	max.
Holding force (passive)	400 N	800 N	min.
Drive properties			
Motor type	NEXLINE®	NEXLINE®	
Operating voltage	-250 V to +250 V, 0 to 100 Hz (typical)	-250 V to +250 V, 0 to 100 Hz (typical)	
Miscellaneous			
Operating temperature range	-40 to 80 °C	-40 to 80 °C	
Material	Aluminum, stainless steel	Aluminum, stainless steel	
Mass	1150 g	1250 g	
Cable length	2.0 m	2.0 m	
Connector	D-Sub 25 (m)	D-Sub 25 (m)	
Recommended controller	E-712.1AM	E-712.1AM	

* Data refer to full step mode operation.



9.1.2 Ambient Conditions and Classifications

The following ambient conditions and classifications must be observed for the N-216:

Area of application	For indoor use only
Maximum altitude	2000 m
Air pressure	1100 hPa to 0.1 hPa
Relative humidity	Max. 80% for temperatures to 31 °C, non-condensing Decreasing linearly to 50% at 40 °C, non-condensing
Operating temperature	-40 °C to 80 °C
Storage temperature	-40 °C to 80 °C
Transport temperature	-40 °C to 80 °C
Overvoltage category (acc. to EN 60664-1:2007 / VDE 0110-1)	II
Protection class (acc. to EN 61140 / VDE 0140-1)	I
Degree of pollution (acc. to EN 60664-1:2007 / VDE 0110-1)	1
Degree of protection (acc. to IEC 60529)	IP 20

9.2 Maximum Ratings

The linear actuator is designed for the following operating data:

Model	Mode of Operation	Maximum Operating Voltage	Maximum Operating Frequency or Velocity (Unloaded)	Maximum Power Consumption ¹⁾
				
N-216.101 / N-216.1A1	Analog	+250 V; -250 V	1500 Hz	3.5 W ²⁾
	Full step		600 µm/s	6.6 W
	Nanostepping		400 µm/s	
N-216.201 / N-216.2A1	Analog	+250 V; -250 V	2000 Hz	7 W ²⁾
	Full step		600 µm/s	13.2 W
	Nanostepping		400 µm/s	

- 1) for constant dynamic operation (not recommended!)
- 2) at full amplitude and max. frequency of 100 Hz

9.3 Mechanical Load Capacity

Maximum values for torque and forces

Negative values in the table correspond to a reversal of the effective direction according to the following figure.

Parameter	Permissible Values	
	N-216.101 / N-216.1A1	N-216.201 / N-216.2A1
Passive force (holding force, linear actuator currentless) F_h	- 400 N to 400 N	- 800 N to 800 N
Active force (drive force) F_p	- 300 N to 300 N	- 600 N to 600 N
Lateral force F_l	- 20 N to 20 N	- 20 N to 20 N
Torque M_{rot} in the direction of the rod axis	- 0.5 Nm to 0.5 Nm	- 0.5 Nm to 0.5 Nm
Torque M_l generated by lateral force (radial; not shown)	- 0.5 Nm to 0.5 Nm	- 0.5 Nm to 0.5 Nm

The following figure shows the directions of acting forces and torques as examples. Depending on the orientation of the setup, effects of gravity must be included in the calculation.

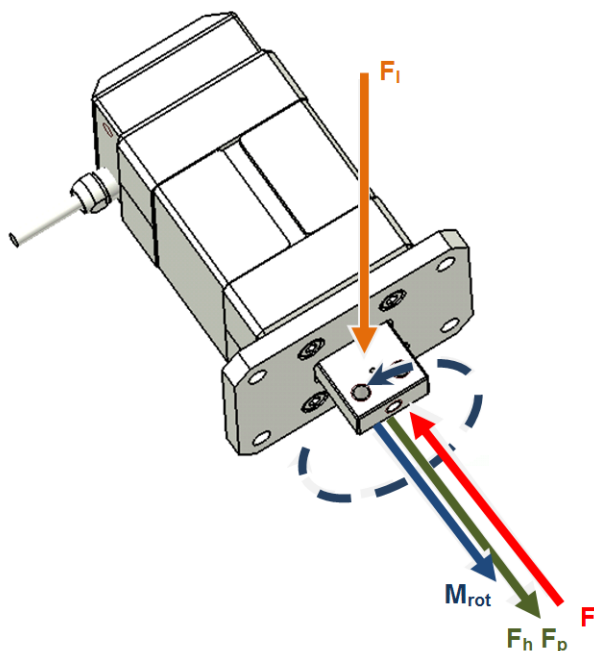

Figure 11: Forces and torques potentially affecting the rod (schematic)

- 1 F_p : Active force (direction for forward motion of the rod) or
- 2 F_h : Holding force (when the rod is at rest)
- 3 F : Force generated by load (positioning or holding)
- 4 F_l : Lateral force
- 5 M_{rot} : Torque (e.g. in the case of load mounting; dashed: direction of action of the causal force)

Velocities and step sizes when the drive is loaded

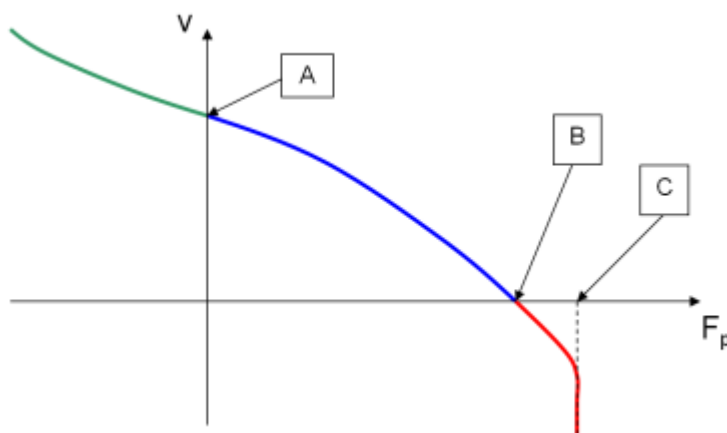

Figure 12: Velocity v as a function of the active force F_p (qualitative)

- F_p : Active force
- v : Velocity of the rod
- Special conditions:
- A: No load
- B: Stop
- C: Slippage

With increasing mass of the load (and thus the active force to be generated), the achievable step size of the drive elements and thus also the maximum velocity of the rod decrease (see explanations of the operation of the NEXLINE® drive in the manual of the controller). The relationships are qualitatively shown in the above diagram.

In the unloaded state (point A), maximum step size and velocity are attained for horizontal mounting of linear actuator and load when no pull force acts in the direction of the rod axis.

Pull forces acting on the rod (e.g. gravity in the case of vertical mounting or, in relation to the horizontal line, inclined mounting of the system) can support the rod motion and cause the velocity to increase further (area left of point A).

On the contrary, the linear actuator applies the maximum active force to compensate for the maximum permissible load (point B). In this state, the velocity drops to 0.

In the currentless state of the linear actuator, the rod is clamped (holding force; generated by the preloaded piezo assemblies). Consequently, the position of a coupled load is held with a permissible load. If the holding force is overcompensated by an impermissibly high load, the clamping effect of the piezo assemblies on the rod is lost (slippage, point C).

Compared to the velocity, analog conditions result for the step sizes in normal operation (see graph, range to the left of B).

9.4 Dimensions

9.4.1 N-216 Actuator

The dimensions apply for any model of N-216. **View partly with mounted flanges.**

Dimensions in mm. Note that the decimal places are separated by a comma in the drawings.

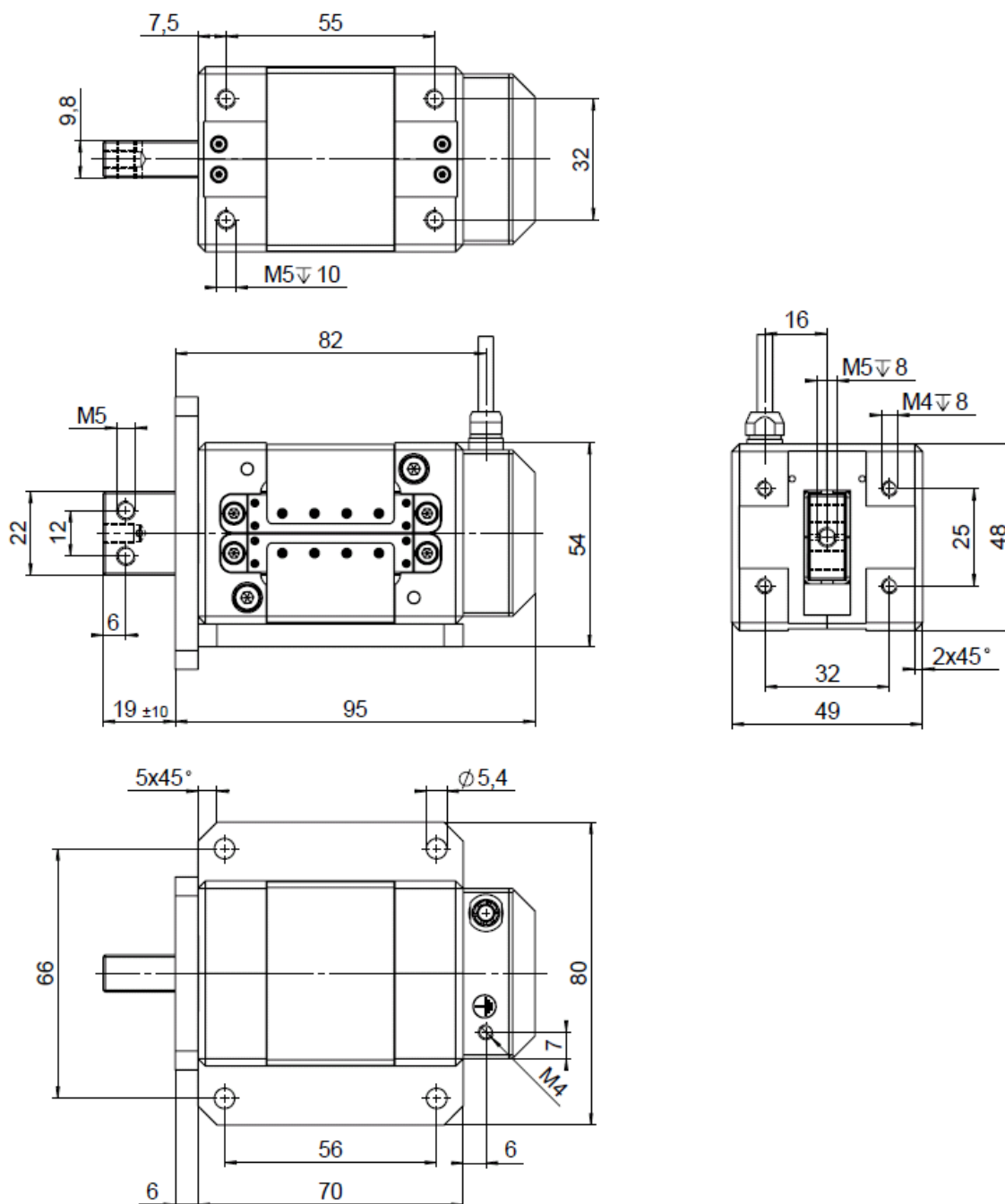

Figure 13: Dimensions N-216, rod in center position

9.4.2 N216E0006 Mounting Flange A

Dimensions in mm. Note that the decimal places are separated by a comma in the drawings.

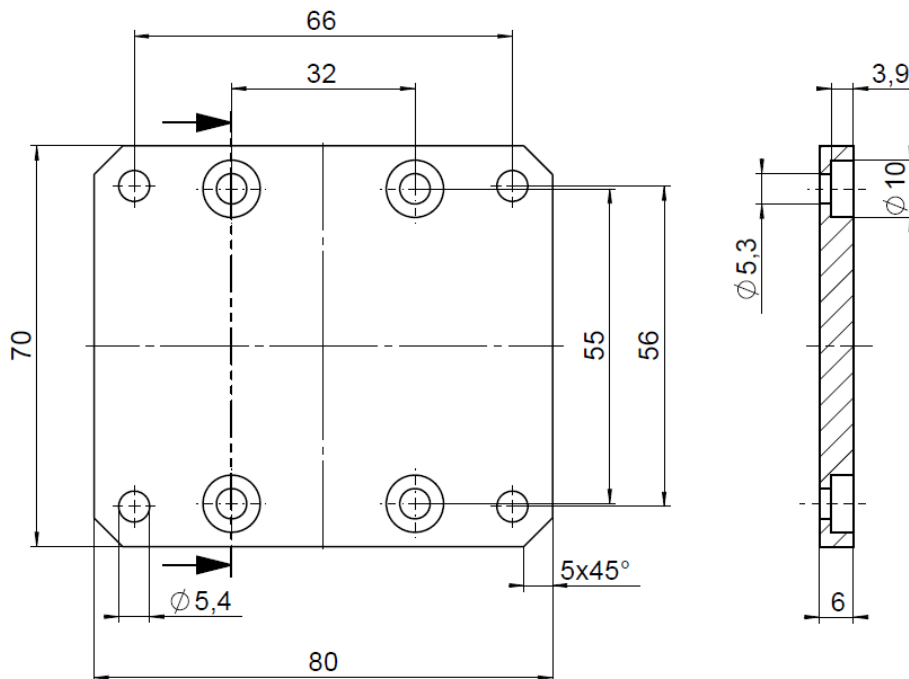

Figure 14: Dimensions of the mounting flange A (N216E0006)

9.4.3 N216E0008 Mounting Flange B

Dimensions in mm. Note that the decimal places are separated by a comma in the drawings.

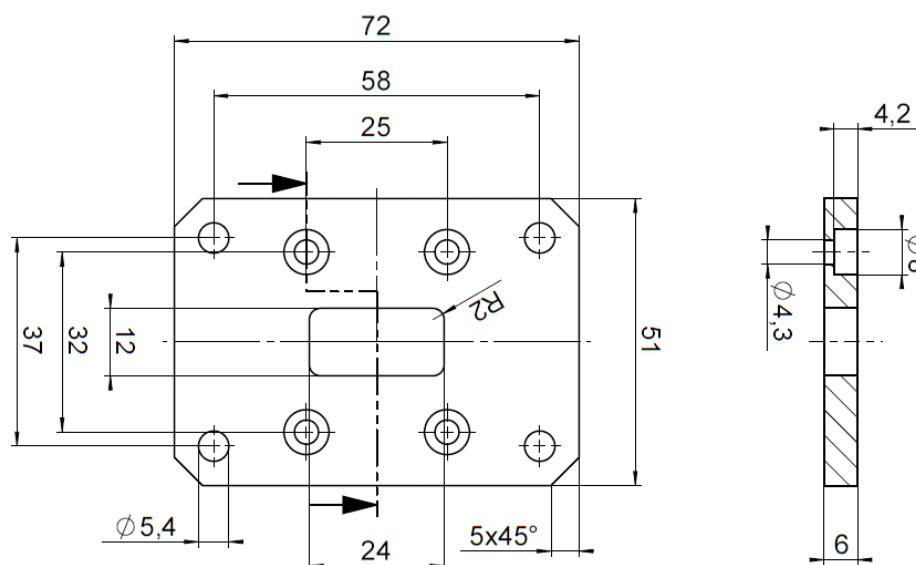

Figure 15: Dimensions of the mounting flange B (N216E0008)

9.5 Pin Assignment (D-Sub 25, m)

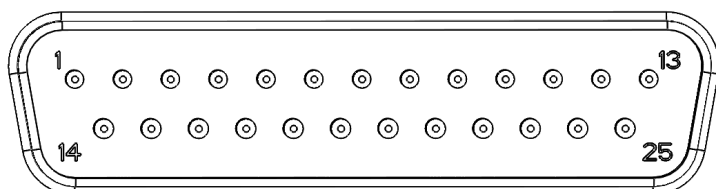

Figure 16: D-Sub 25 connector (m), mating side

9.5.1 N-216.101 / N-216.201

Pin	Signal*	Function	Direction
1	D1+	Supply voltage of shearing group 1 (-250 V to 250 V)	Input
2	-		
3	-		
4	D2+	Supply voltage of shearing group 2 (-250 V to 250 V)	Input
5	-		
6	-		
7	C1+	Supply voltage of clamping group 1 (-250 V to 250 V)	Input
8	-		
9	-		
10	C2+	Supply voltage of clamping group 2 (-250 V to 250 V)	Input
11	-		
12	-		
13	-		
14	-		
15	D1-	Ground of shearing group 1	GND
16	-		
17	-		
18	D2-	Ground of shearing group 2	GND
19	-		
20	-		
21	C1-	Ground of clamping group 1	GND
22	-		
23	-		
24	C2-	Ground of clamping group 2	GND
25	-		

* The character "-" indicates that the corresponding pin is not connected.

9.5.2 N-216.1A1 / N-216.2A1

Pin	Signal*	Function	Direction
1	D1+	Supply voltage of shearing group 1 (-250 V to 250 V)	Input
2	+5V (Sensor)	Supply voltage of encoder	Input
3	+5V (Ref)	Supply voltage of reference point switch	Input
4	D2+	Supply voltage of shearing group 2 (-250 V to 250 V)	Input
5	-		
6	-		
7	C1+	Supply voltage of clamping group 1 (-250 V to 250 V)	Input
8	GND (Sensor)	Ground of encoder	GND
9	GND (Ref)	Ground of reference point switch	GND
10	C2+	Supply voltage of clamping group 2 (-250 V to 250 V)	Input
11	-		
12	Ref-	Reference point switch	Output
13	Ref+	Reference point switch	Output
14	-		
15	D1-	Ground of shearing group 1	
16	Sin+	Encoder signal 1 (sine)	Output
17	Sin-	Encoder signal 1 (sine)	Output
18	D2-	Ground of shearing group 2	GND
19	Cos+	Encoder signal 2 (cosine)	Output
20	Cos-	Encoder signal 2 (cosine)	Output
21	C1-	Ground of clamping group 1	GND
22	-		
23	-		
24	C2-	Ground of clamping group 2	GND
25	-		

* The character "-" indicates that the corresponding pin is not connected.

10 Old Equipment Disposal

In accordance with the applicable EU law, electrical and electronic equipment may not be disposed of with unsorted municipal wastes in the member states of the EU.

When disposing of your old equipment, observe the international, national and local rules and regulations.

To meet the manufacturer's product responsibility with regard to this product, Physik Instrumente (PI) GmbH & Co. KG ensures environmentally correct disposal of old PI equipment that was first put into circulation after 13 August 2005, free of charge.

If you have old PI equipment, you can send it postage-free to the following address:

Physik Instrumente (PI) GmbH & Co. KG
Auf der Römerstr. 1
D-76228 Karlsruhe, Germany



11 EU Declaration of Conformity

For the N-216, an EC Declaration of Conformity has been issued in accordance with the following European directives:

- Low Voltage Directive
- EMC Directive
- RoHS Directive

The applied standards certifying the conformity are listed below.

- Safety (Low Voltage Directive): EN 61010-1
- EMC: EN 61326-1
- RoHS: 50581