

REPEATABILITY
SCANNER
PRECISION
RELIABILITY
LEVER-AMPLIFIED
TIP/TILT
PLATFORMS
PIEZO ACTUATOR
POSITIONING WITH
PIEZO SYSTEMS
DUTY CYCLE
STEP RESPONSE
MOTION CONTROL
ACCURACY
PARALLEL
KINEMATICS
HIGH DYNAMICS
STIFFNESS
CAPACITIVE SENSOR
SUBNANOMETER

Positioning with Piezo Systems

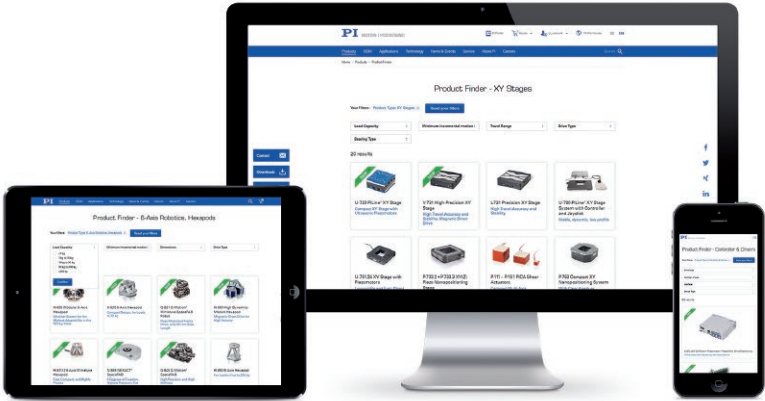

Product Finder Online – What is the easiest way for you to find the best positioning solution?

The printed catalog is a major showcase for PI and, as well as presenting the entire product range, it also acts as a reference for all of our motion solutions. However, to take advantage of the latest products and developments, we recommend using the product finder on the PI website www.pi.ws.

How to use the product finder:

Select the product type specified by the axes of motion required. Selection of more criteria expands or shortens the list of results. Select more than one filter at a time, for example, to find positioning stages designed for higher load capacity, too.

INTRODUCTION

Markets and Applications	4
Custom Examples Picture Wall	6
The PI Group – A Strong Partner for Industry and Research	9
PI Milestones	10
Expert Consulting	12
Engineering Design Expertise and Customization	13
Production Capabilities	14
Vacuum Know-How	15
From 1-off to Series: OEM Users Benefit From Maximum Flexibility	16
Global Service and After-Sales	17
What to Expect from PI Piezo Systems	18

PRODUCTS

Nanopositioning Piezo Stages	22
Linear Stages	24
Vertical Stages	34
XY Stages	44
Multi-Axis Stages	54
Scanners for Microscopy	78
Microscopy Solutions	78
PIFOC Objective Scanners	80
Vertical Sample Stages for Microscopys	94
PInano® Piezo Flexure XY(Z) Scanners	98
Tilting Mirrors	104
Piezo Actuators with Guiding and Preload	118
PiezoMove Lever Actuators	120
Preloaded Actuators with Low Drive Voltage to 100 V	128
Preloaded Actuators with High Drive Voltage to 1000 V	146
Piezo Benders	156
PiezoWalk OEM Piezomotors	158
OEM Actuators	160
PiezoWalk Controllers	170
Capacitive Feedback Sensors	178
Sensor Heads	180
Signal Conditioner	184
Piezo Controllers and Drivers	186
Single-Channel Piezo Controllers	188
Multi-Channel Piezo Controllers	202
Modular Multi-Channel Piezo Controllers	210
Controller for Piezo Benders	222
High Dynamics Piezo Drivers	224
Piezo Drivers	234
Terms and Technology Glossary	240

More information, step-files and downloads are available from our website www.pi.ws.
All data subject to change without notice, © PI 2017.

Markets and Applications

Microscopy: Position Lens or Specimen

Optical methods have been relying on PI positioning systems for years, e.g. for aligning optical systems or samples. Piezo actuators and motors are best for replacing conventional motor/spindle driven systems because they are more compact, more precise and faster. Other non-optical microscopic processes, such as SEM (scanning electron microscope) and AFM (atomic force microscope), use PI systems due to their high accuracy and dynamics.



Image: WITec GmbH

Mechanical Engineering

Vibrations of a piezo actuator reduce the processing times for high-precision micro-sized holes

- Processing, e.g. out-of-round turning with piezo actuators
- Precise positioning, even of high loads in six degrees of freedom
- Setup of testing systems



Image: ICT-IMM

Industrial Manufacturing and Quality Assurance, Optical Metrology

Optical inspection systems in the semiconductor industry utilize the performance features of PI systems, for example, for controlling surface structures on wafers after major manufacturing steps or for final quality inspection of flat-screen monitors with white light interferometry. PI piezo motor and piezo actuator systems are used for active alignment or autofocus tasks in high-speed semiconductor production, where they perform precise adjustment of wafers, imaging optics, and the masks.



Image: Polytec GmbH

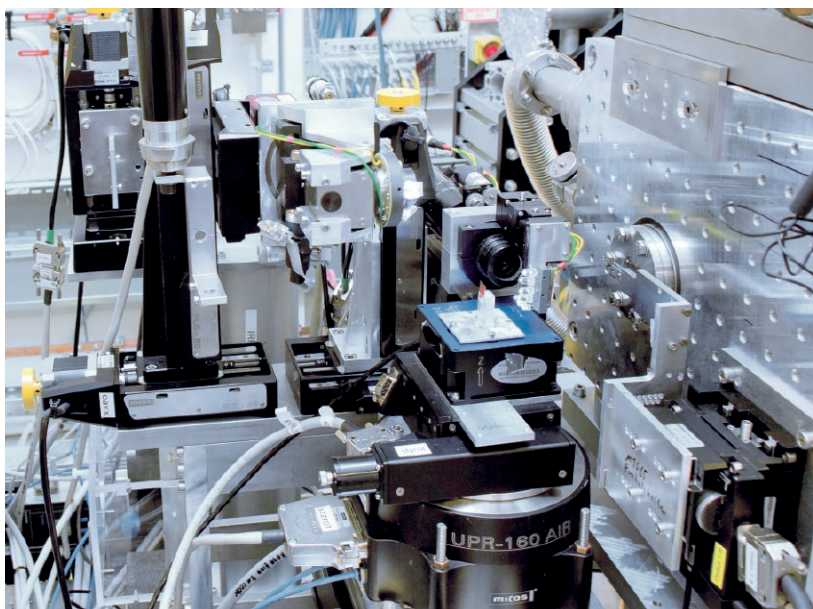

Scientific Instrumentation

From small-scale laboratory automation to experimental endstations of beamlines in synchrotrons and other particle accelerators, a large variety of applications in the scientific environment benefits from piezo based, sub-nanometer precision scanning and positioning. The conditions of use vary, and include ultrahigh vacuum, non-magnetic or cryogenic.

The sample positioning setup inside the holography endstation (Image: M. Osterhoff, Institute for X-Ray Physics, Georg-August-University Göttingen)

Photonics Packaging, Silicon Photonics

During production and inspection of components with optical data transmission, it is important to align fibers or fiber arrays for optimum coupling with the highest possible accuracy. Position tolerances way under 50 nm are common and multi-channel inputs and outputs require simultaneous alignment in several axes.

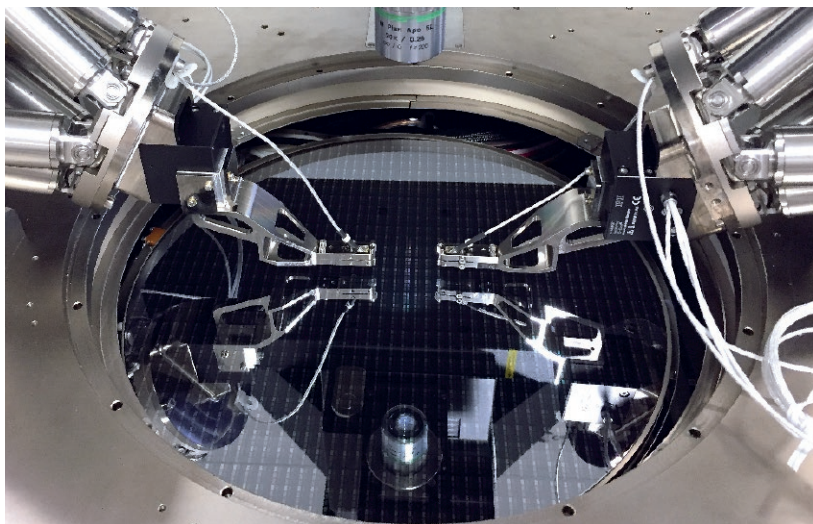

18-Axis double alignment system provides fast NxM alignment of SiP devices in wafer probers. Cascade Microtech's pioneering CM300xi photonics-enabled engineering wafer probe station integrates PI's Fast Multichannel Photonics Alignment systems for high throughput, wafer-safe, nano-precision optical probing of on-wafer Silicon Photonics devices. (Image: Cascade Microtech, a FormFactor company)

Astronomy

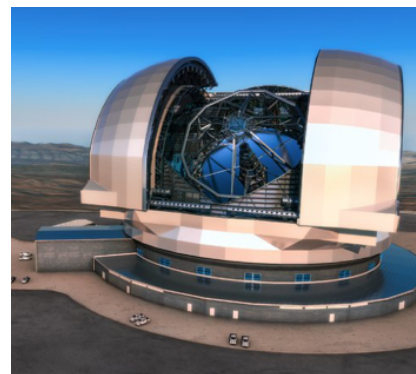

Piezo-based solutions are key to precision in the World's largest telescope, the ELT of the European Southern Observatory (ESO). This artist's impression shows the European Extremely Large Telescope (E-ELT) in its enclosure. The E-ELT will be a 39-metre aperture optical and infrared telescope sited on Cerro Armazones in the Chilean Atacama Desert. PI provides the nanometer-precise actuation of the main mirror segments, as well as other piezo-based, highly customized motion solutions for precision-critical points of operation within the telescope. (Image: ESO/L. Calçada)

Custom Examples Picture Wall



Hybrid actuator that consists of a classical PICMA® multilayer piezo actuator and a PIRest piezo actuator. While the PIRest part corrects the offset position continuously in a range of up to 10 µm, an additional dynamic motion is performed via the PICMA® actuator. This can be helpful for dynamic compensation of vibration in a range of several 10 Hz, for readjusting a focal plane during a measuring or scanning process, or for controlling a laser beam in measuring technology or material processing

Parallel-kinematic piezo hexapod for fast scanning in 6 degrees of freedom that features 200 µm of linear travel and up to 20 mrad tip / tilt motion. With a load capacity of 50 g the hexapod is perfectly adapted for use in beam-line experiments, complex optical positioning or alignment tasks



This 6D NanoCube offers motion in six degrees of freedom and a large clear aperture of 25 mm x 25 mm and 200 µm of motion in all linear axes. The 500 g-load capacity eases the integration into complex optical positioning or laser alignment setups, for example in experimental setups at beamlines. Capacitive feedback sensors allow for optimal repeatability



PiezoWalk® piezo-based drives combine excellent long-term stability and repeatability with a small form factor. This positioner is used for precise readjustment of monochromator crystals in an X-ray spectrometer

Piezo hexapod for fine adjustment and active, dynamic error correction. The space-saving, parallel-kinematic design allows a low overall height, and motion in six degrees of freedom. Resonant frequencies up to 1 kHz ensure fast position control. An optional integration of PIRest technology additionally provides for permanent, static positioning over long time periods





Power PIFOC Nosepiece Nanopositioner for high-resolution microscopy achieves high dynamics and nanometer resolution for heavy objectives



Six-axis, piezo-based positioning system for positioning a specimen in a UHV environment

The UHV-compatible miniature piezo hexapod provides high-precision positioning even in strong magnetic fields

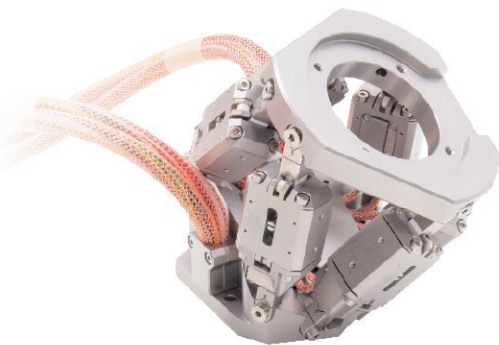

Compact piezo actuator for generating oscillations even of heavy loads which is used to accelerate high-precision EDM machining processes



This NEXLINE® Z / tip / tilt platform for the semiconductor industry is used for wafer alignment where it provides drift-free position stability during scanning and wafer processing

Custom Examples Picture Wall

System solutions for microscopy: PIFOC and 6-axis microrobot with NEXACT® piezo walking drives and their dedicated motion controller

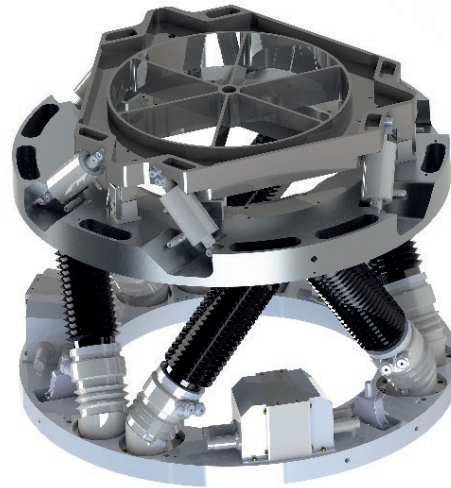

This double piezo hexapod combines in one system the coarse and fine travel for alignment of the M2 mirror of a large telescope

Non-magnetic stages made from titanium or other non-magnetic materials and driven by NEXLINE® piezo walking motors are intended for use in cryogenic environment to 77°K. This requirement not only arises from research laboratories, but also from telescopes exposed to large changes in environmental temperatures

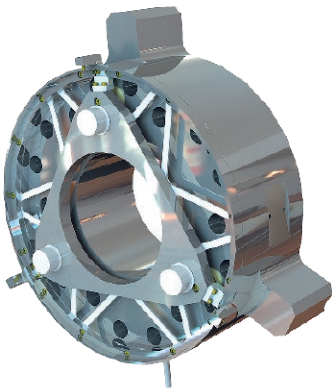
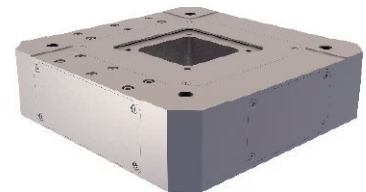

This fast tip / tilt platform corrects the image jitter at an M5 telescope mirror. A high bandwidth and extremely high resolution is essential to achieve a high image quality



The differentiating feature of this NEXLINE® Z / tip / tilt positioner is the high long-term stability, which is required to align M3 and M6 mirrors in a telescope, for example

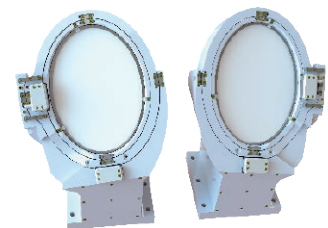

Gimbal mount mirrors are often used in astronomy to provide a tip / tilt axis in plane with the mirror surface for optimum adjustment in 2 angles

The PI Group – A Strong Partner for Industry and Research



The PI headquarters in Karlsruhe, Germany, manifests the continuous growth. In front, the 2017 Technology Center

Over the last four decades, PI (Physik Instrumente) has developed into the leading manufacturer of nanopositioning technology. The key element and motivation of the entrepreneurial behavior have always remained the same: Finding the best possible solution for the customer.

PI is well known for the quality of its products and has been one of the leading players in the global market for precision positioning technology for many years. One of the most important building blocks for this is the team spirit within the international PI family, which is based on mutual understanding and support that goes beyond international borders and functional restrictions.

PI is a privately owned company with healthy growth, more than 1000 employees worldwide and a flexible, vertically integrated organization, which enables PI to fulfill almost any request in the field of innovative precision positioning technology. The foremost priority for PI is to be a reliable and highly qualified partner for the customer.

The PI Group Milestones

A Success Story

Well known for the high quality of its products, PI (Physik Instrumente) has been one of the leading players in the global market for precision positioning technology for many years. PI has been developing and manufacturing standard and OEM

products with piezo or motor drives for more than 40 years. In addition to four locations in Germany, the PI Group is represented internationally by fifteen sales and service subsidiaries. All of our customers worldwide can rely on this.

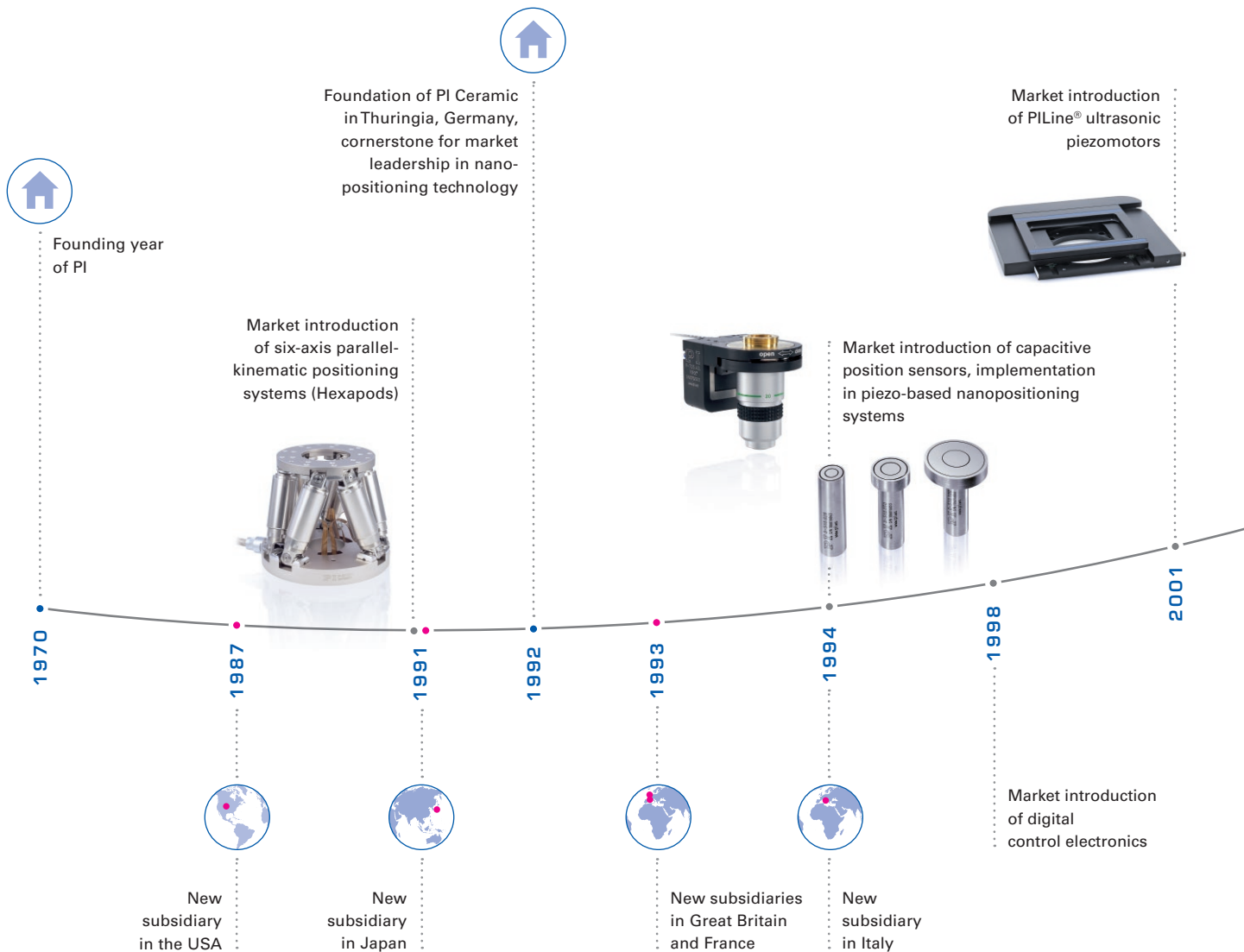

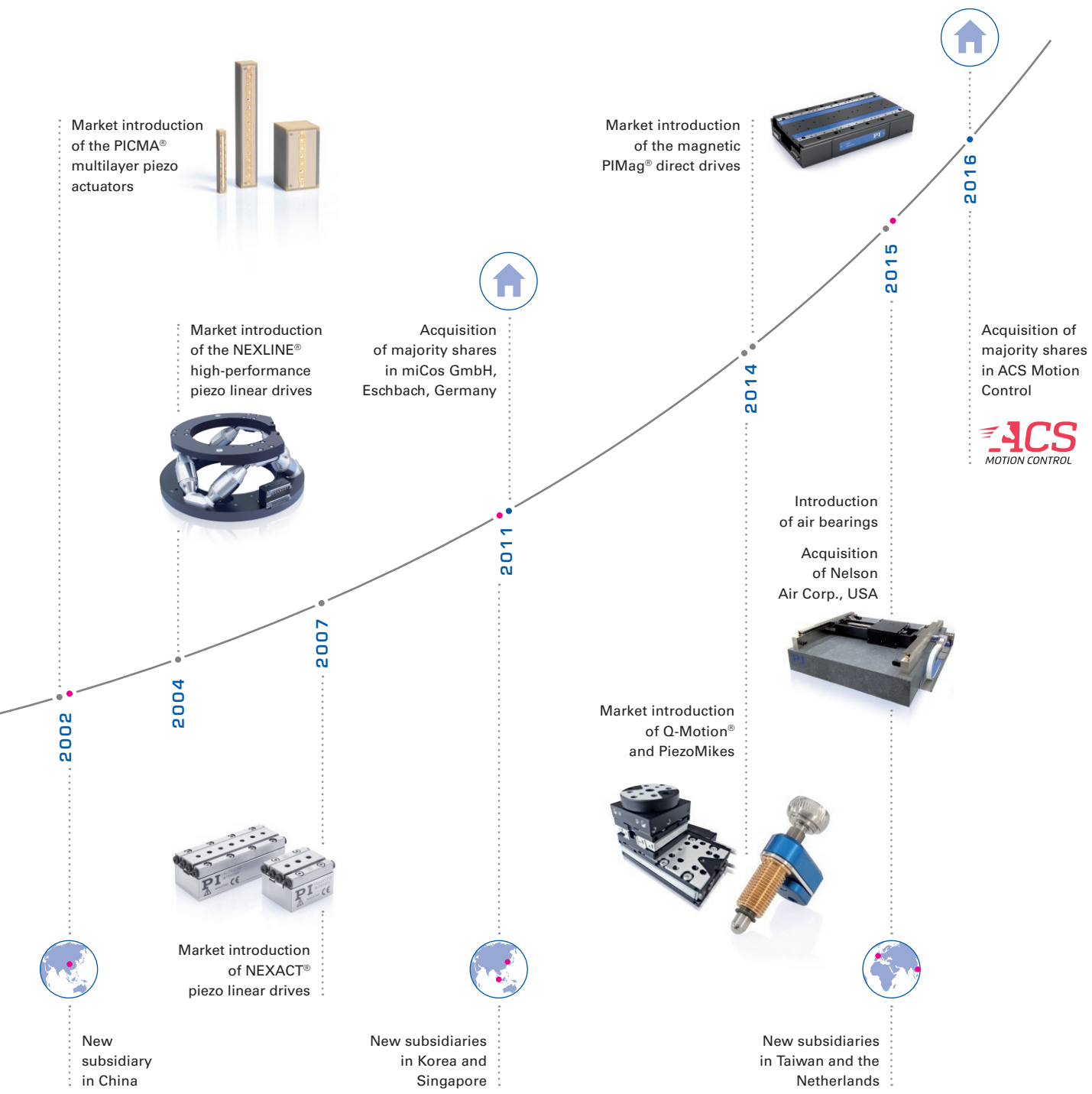

Expert Consulting



Time for qualified technical consultation is crucial for the success of high-tech projects

The PI Group can respond precisely to what customers want: Specific requirements can often only be satisfied by customized solutions – solutions that can be found by unconventional and creative thinking. Together with the customers, PI plans and realizes individual solutions for the most varied applications and integration levels. And that means that PI's customers can always be sure that they will get the best solution every time.

Customers directly benefit from:

Highly Qualified Consultancy Through Trained Specialists

Individual advice often is key to solve a complex problem. PI sales engineers are ready to come on site with all the time necessary for a solid understanding of the topic. Or they will gladly meet at the PI head office. All PI sales engineers have a background in natural sciences or engineering, and have up to 20 years of experience in optical, micro- or nanopositioning technology.

International Support

PI subsidiaries and distributors in many countries across the world guarantee global support – a decisive advantage, especially for globally operating customers. PI has its own sales and service offices in all important markets. Moreover, the company maintains testing devices for nanometrology on three continents. PI Shanghai and PI USA have additional development and manufacturing resources that allow rapid local reaction to custom-engineered specifications.

Engineering Design Expertise and Customization

Unique Technological Breadth

The technological diversity of the PI Group is unrivalled all over the world. PI develops, manufactures, and qualifies all its core technologies itself. PI is therefore not dependent on components available on the market. That puts PI in a position to offer its customers the most advanced products for motion and positioning tasks – without technological restriction.

Customized Solutions

With this background, PI develops positioning solutions with innovative drive technologies for high-tech applications worldwide. PI covers the whole motion range from finger-tip sized nanopositioners to large-scale stages with long travel ranges, through their plethora of different drive and guiding systems.

Core Technologies

- In-house manufacturing of piezo components and piezo actuators
- Magnetic direct drives: linear motors and voice coil
- Air bearings, magnetic and flexure guides
- Comprehensive range of piezo motor technologies
- Nanometrology sensors
- Parallel-kinematic systems for positioning in six axes (Hexapods)
- Motion control technology
- Software

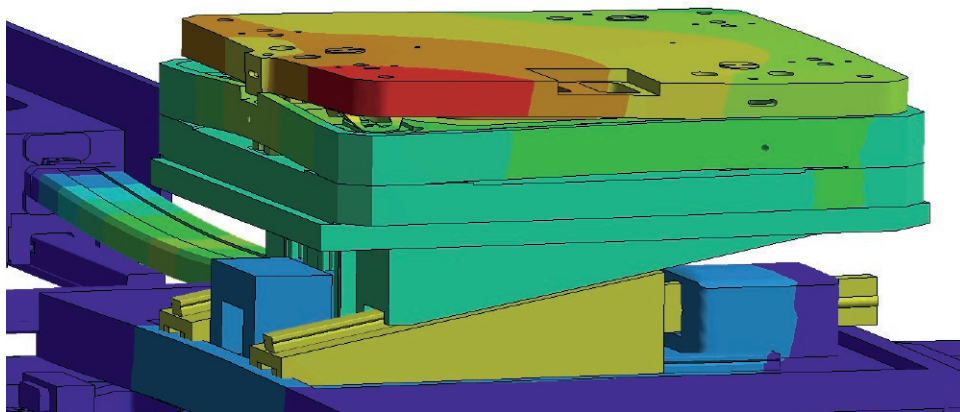
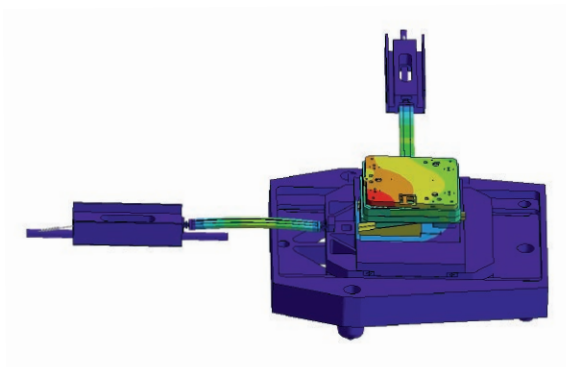

Maximum performance of precision systems is achieved through extensive design and analysis expertise, using equipment built in-house with proprietary techniques. See here the modal analysis of a complex multi-axis system that includes linear guide elements as well as mixed piezo drive technologies like PICMA[®] multilayer actuators and PiezoWalk[®] walking drives, and PIMag[®] magnetic drives

Production Capabilities



PI's flexibility in serial production allows for fast adaptation of both processes and quantities

A modern production management and an integrated management system allow PI to guarantee the high quality of its products, processes, and services. The continual improvement of organization and processes is an integral part of the corporate culture. KAIZEN workshops and an active innovation management are important elements for achieving this.

The production processes for the standard range are made flexible by the fractal production structure and it is therefore possible to manufacture even large series with full process control. Active, system-based requirements management makes it possible to dispense with comprehensive storage facilities.

Vertical Production Range and Production Capacity

The product spectrum ranging from the two-ton hexapod to the 10-gram nanopositioner requires PI to have the equipment and technologies at its disposal that allow the systems to be manufactured, assembled, and qualified.

- 13,000 m² of overall production space
- 5,000 m² for cleanrooms
- Air-conditioned and vibration-proof measuring conditions
- Vacuum chambers for startup and residual gas analysis
- Measuring technology with traceable, calibrated measuring equipment
- Monitoring of piezo actuator technology from material composition to final inspection
- In-house manufacturing of positioning sensors
- Production hall with measuring technology for heavy loads
- Fractal production organization

Vacuum Know-How

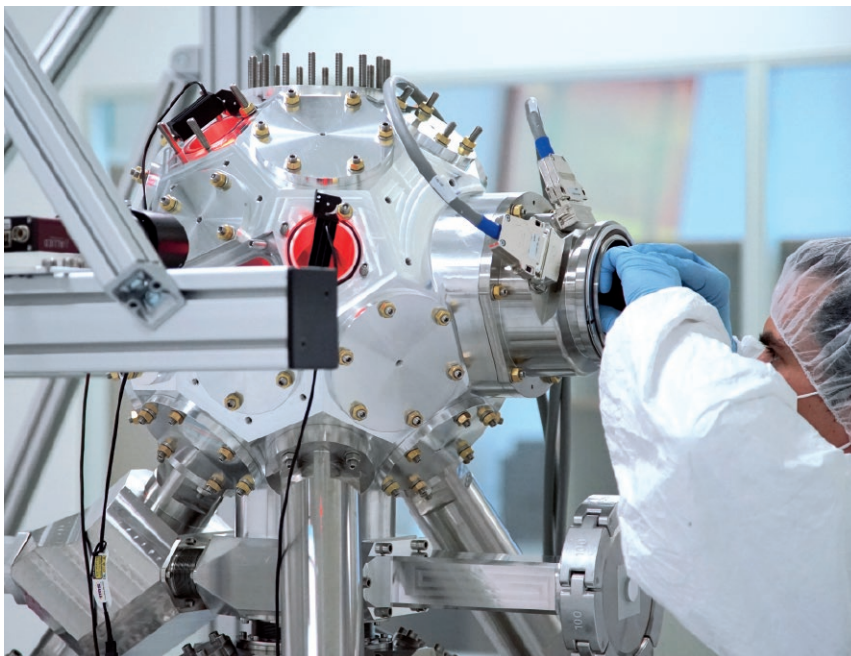

PI offers high-precision solutions for positioning in vacuum conditions to 10^{-10} hPa. Positioning solutions in a vacuum follow clearly defined constraints. This applies to the limited installation space, as well as prevention of contamination and excessive heat input.

Selection of the optimum drive technology for the respective application and the mechanical design must be matched exactly to the required load capacity and velocity as well as the intended operating and planned duty cycles.

The handling regulations for vacuum positioning systems are just as important as the design principles. Cleanrooms are available for assembling larger parts. Suitable packaging and the corresponding instructions for the recipient are part of shipping.

Vacuum chambers are available in several sizes with vacuum levels down to 10^{-10} hPa, where start-up and measurement of outgassing, but also interferometric measuring of position accuracy under real operating conditions is possible.

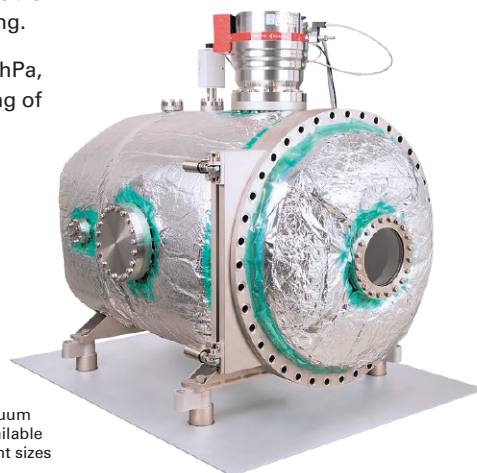

At PI, several vacuum chambers are available in various different sizes

From 1-off to Series: OEM Users Benefit From Maximum Flexibility

PI serves both the research and industrial markets. The complete control over the design and manufacturing process provides our customers with significant competitive advantages. Optimized processes allow PI to deliver customized products in quantities up to several 100,000 units per year at low cost and right on time. The range of OEM products offered by the PI Group varies widely, ranging from “bare” actuators and sensors to highly integrated parallel-kinematic positioning systems. Evaluation of pre-production run samples, test procedures, production processes and quality management are all included in the development process.

Services

- Global account management: Close proximity to the customer thanks to international presence
- Risk assessment from design to delivery
- Depending on the task: From the drive to the turnkey system
- Copy exactly policy
- Preparation of internal and external certification
- Production of series of several 10,000 units in the shortest time
- Sustainable spare parts service
- Manufacturing and testing capacities from functional samples to mass production

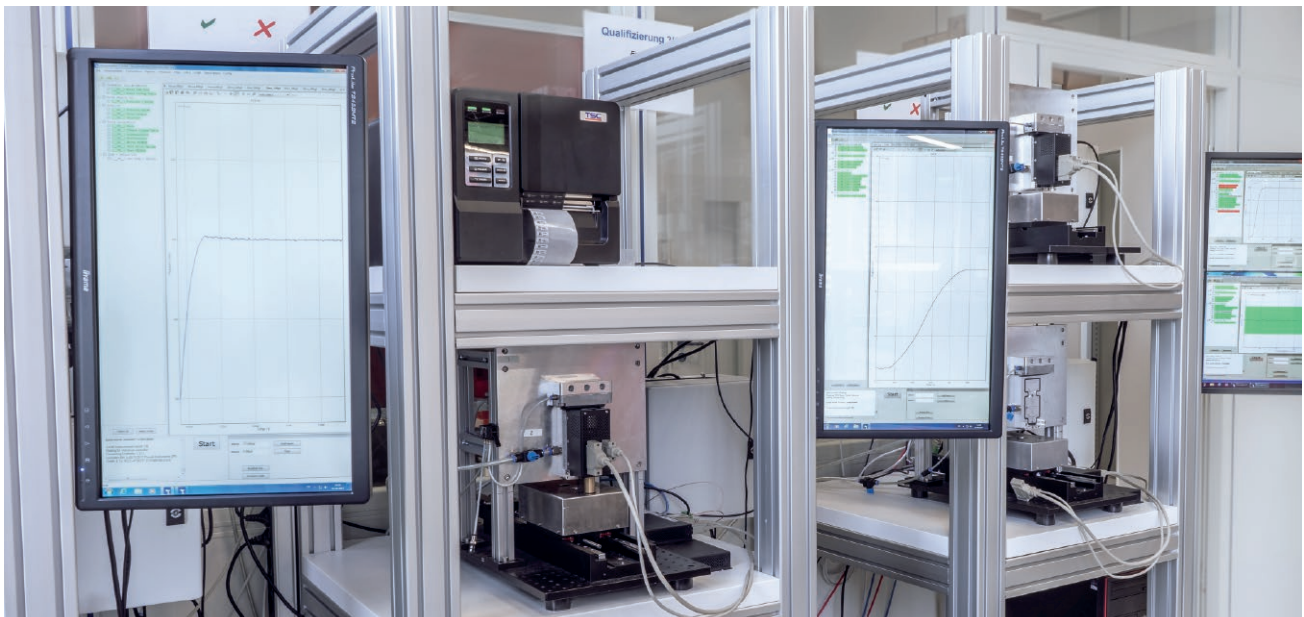

Standardized performance control with full documentation of individual measurement charts

Global Service and After-Sales



On-site training is key to optimize and maximize the potential of new PI systems

Start-Up, User Training and Life Long Support

PI is dedicated to supporting its customers right from the initial consultation through to when a customer has purchased a PI system. Beyond that, PI's services division is committed to ensuring that every aspect of owning a PI system is catered for.

Global Coverage

Supported by 4 Global Service Hubs in Asia, China, Europe and USA, with field product specialists working from these hubs, PI is able to support all technologies and customer applications via this global services team.

PI's Standard On-Site Services

- Set up and Commissioning – On-site support to un-box, set-up and commission the PI system
- Training Program – User training on software and programming, through to optimization of system performance
- Maintenance Systems Health Check – Preventative maintenance to prolong the life of the motion device
- Support – Ongoing remote and on-site support to maximize system uptime and provide maintenance for the whole life of any system

Contracted Services

Customers subscribing to Contractual Support Services will receive commitment from PI to achieving agreed Service Levels. These include responding to the customer's first contact and providing remote technical support, through to response times for a PI expert to be on site, either to repair or replace a defective unit.

Extended Warranty

Most customer applications require PI's systems to be operational beyond the standard warranty period. Extending the warranty for additional year(s), is simply extending the customers peace of mind and PI's commitment that the product will not fail due to poor workmanship or faulty materials. Should a customer's system then fail due to these conditions, PI will cover the costs to repair or replace it.

What to Expect from PI Piezo Systems

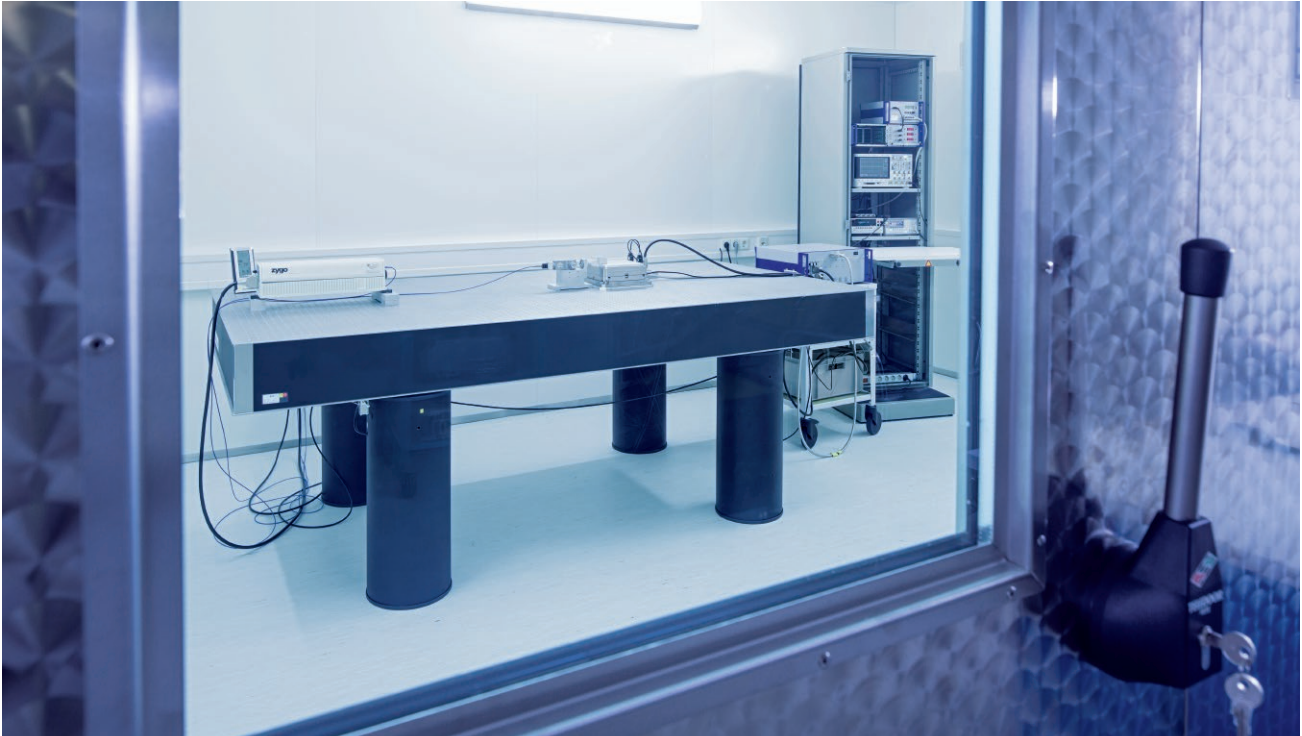

View of a nanometrology laboratory with six-fold insulation. Qualifying is done here fully automatically under controlled ambient conditions

Fully Equipped System with Comprehensive Scope of Delivery

PI attaches great importance to usability, conformity to specifications and ease of initial startup of their piezo systems. To achieve this, each piezo system only leaves the factory when it is ready for immediate use and together with a main specification protocol. The scope of delivery includes the following essential components:

- Typically, the hardware consists of the piezo stage, all suitable cabling, and the piezo controller. In case a separate power supply is required, it is also part of the package. Communication cables are included for each available interface.
- The detailed user documentation clearly explains the functions and handling instructions.
- Digital piezo controllers come with an extensive software package. For easy startup and system configuration, the PIMikroMove® utility program is included in the scope of delivery. Connection to the customer's software is possible via LabVIEW drivers and shared libraries / DLLs. An outstanding feature is that system programming is identical for all PI controllers – combined control of a variety of different controllers is therefore possible without any problems. All parameters can be set and checked via software.

Individually Calibrated Systems

Each piezo system undergoes full testing and control before shipping. The piezo stage and controller are calibrated together as standard. Therefore, optimal interaction and performance of electronics and mechanics is guaranteed. All calibration data can be determined according to the particular application and applied payload. Additional tuning at the customer's site is therefore not necessary. These comprehensive services are already included in the scope of delivery.

Controller Compatibility With ID Chip

Many of PI's piezo systems use an ID chip integrated in the stage that contains the active parameter set. These stages can be combined with any PI digital piezo controller. The reliability and uptime of production processes can thereby be optimized, because recalibration of the stage is not necessary e.g., when the controller needs a software update. This service is always part of the scope of delivery.

Matching of Piezo Systems

With piezo stages that do not contain an ID chip or with analog piezo controllers, the stage and electronics are matched to a fixed pair. Tuning of all operation parameters is done at the factory under full monitoring of specifications. Optimization for customer-specific loads and application-related features can be done on request.

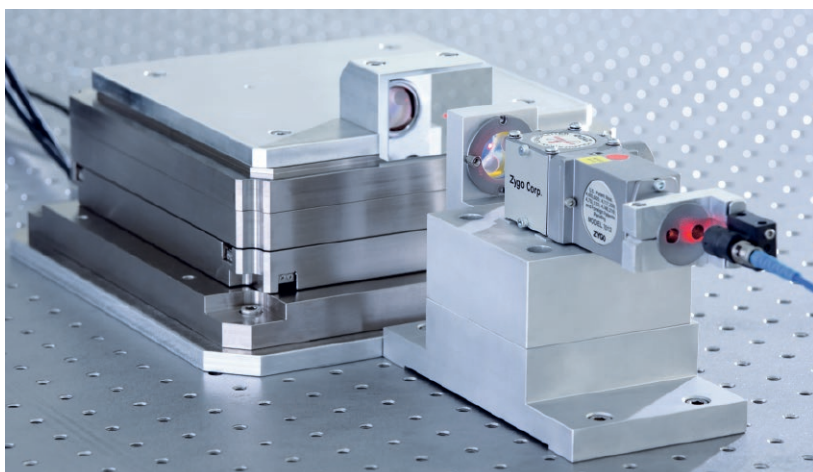

Traceable metrology equipment is the key to calibration with sub-nanometer accuracy

Measurement Reports and Logs for Piezo Systems

For PI, each individual measurement and qualification is an instrument for quality assurance. This makes sure that only those positioning systems leave the premises that are within the guaranteed specifications. All measurements are made with external, verifiable measuring equipment such as high-resolution interferometers, CMMs or other suitable tactile or optical metrology equipment.

The qualification data is verifiable for each individual product. The measurement data is compiled in a database and used for process control. Retracement at product level is particularly interesting for large production runs.

The measurement log is provided with piezo systems. It is therefore possible for the customer to verify the performance of the system with the data measured before it was dispatched and also see which system components are paired or which data set is used within the ID chip.

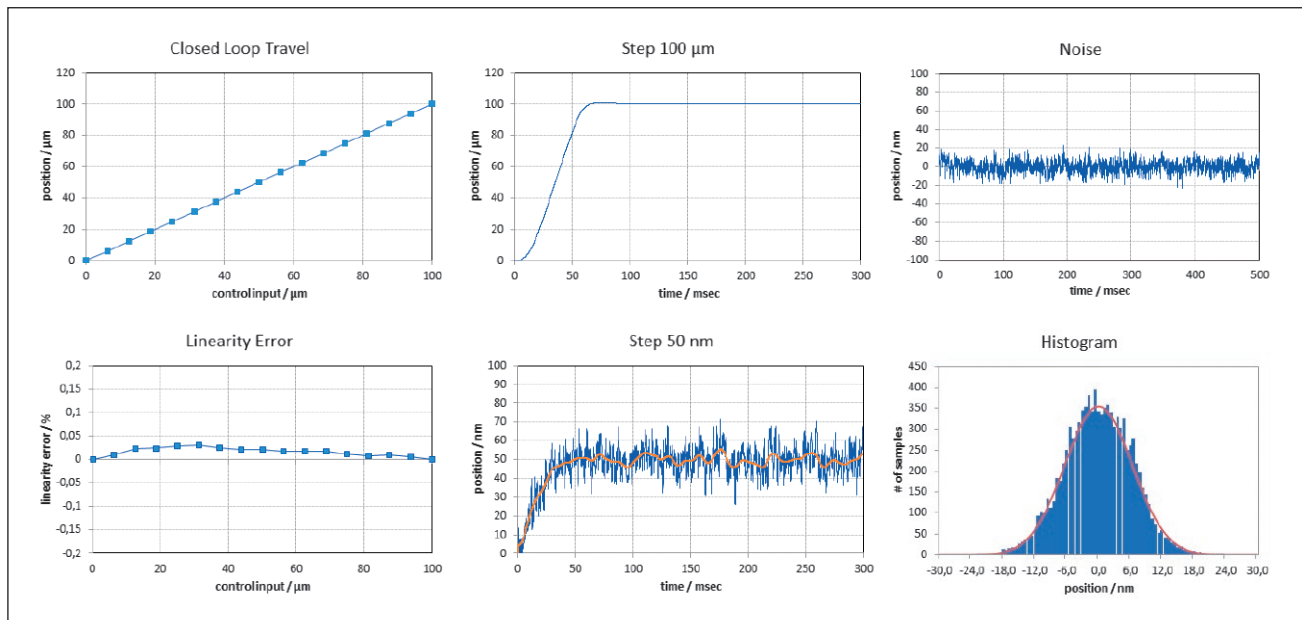

A typical measurement log for a closed-loop nanopositioning system contains data and diagrams on the positioning accuracy, linearity error, settling behavior, and noise. Therefore, the customer can always be sure that he receives a product exactly compliant to the requested specifications.

Reliability and Service for OEM Customers

OEM customers benefit from PI's special service. Individual arrangements in various areas can be agreed, such as:

- „Copy exactly“ agreements
- Spare part availability beyond normal warranty time
- Safety stock for flexible deliveries and back up scenarios
- Integration of customer supply
- Customized packaging, e.g., of preconfigured systems
- Individual labeling of stages or cables

Cables: Stage (LEMO) to Electronics (Sub-D)

P-895.1LDC	Adapter cable LEMO to Sub-D 7W2 (m) for piezo actuator nanopositioning systems with capacitive sensors, 1 channel, 0.3 m. Fits motion controllers with Sub-D 7W2 (f) connector
P-895.3LDC	Adapter cable LEMO to Sub-D 25W3 (m) for piezo actuator nanopositioning systems with capacitive sensors, 3 channels, 0.3 m. Fits motion controllers with Sub-D 25W3 (f) connector
P-895.4LDS	Adapter cable LEMO to Sub-D 37 (m) for piezo actuators and piezo actuator nanopositioning systems with strain gauge sensors, 4 channels, 0,3 m. Fits motion controllers with Sub-D 37 (f) connector

Cables: Stage (Sub-D) to Electronics (LEMO)

P-895.1DLC	Adapter cable Sub-D 7W2 (f) to LEMO for piezo actuator nanopositioning systems with capacitive sensors, 1 channel, 0.3 m. Fits controllers with LEMO connectors (1 × Voltage, 2 × Sensor)
P-895.3DLC	Adapter cable Sub-D 25W3 (f) to LEMO for piezo actuator nanopositioning systems with capacitive sensors, 3 channels, 0.3 m. Fits motion controllers with LEMO connectors (up to 3 × voltage, 6 × sensor)

Cables: Stage (Sub-D) to Electronics (Sub-D)

P-895.2D1DDC	Adapter cable Sub-D 25W3 (f) and Sub-D 7W2 (f) to Sub-D 25W3 (m) for piezo actuator nanopositioning systems with capacitive sensors, 3 channels, 0.3 m. Suitable for controllers with Sub-D 25W3 socket
P-895.2DDC	Adapter cable 2 × Sub-D 7W2 (f) to Sub-D 25W3 (m) for piezo actuator nanopositioning systems with capacitive sensors, 2 channels, 0.3 m. Suitable for controllers with Sub-D 25W3 socket
P-895.3DDC	Adapter cable 3 × Sub-D 7W2 (f) to Sub-D 25W3 (m) for piezo actuator nanopositioning systems with capacitive sensors, 3 channels, 0.3 m. Suitable for controllers with Sub-D 25W3 socket

More Accessories

All PI piezo systems are delivered with a complete and appropriate cable set. The cable length is noted in the data sheet. Additionally, cables can be ordered separately, see lists below.

On request, it is possible to adapt the length of cable sets and material or provide other features. For special environments such as clean rooms or vacuum, PI provides a range of accessories, e.g., feedthroughs and dedicated cables. For optimal system performance, it is recommended to obtain all accessories from PI.

Nanopositioning Piezo Stages

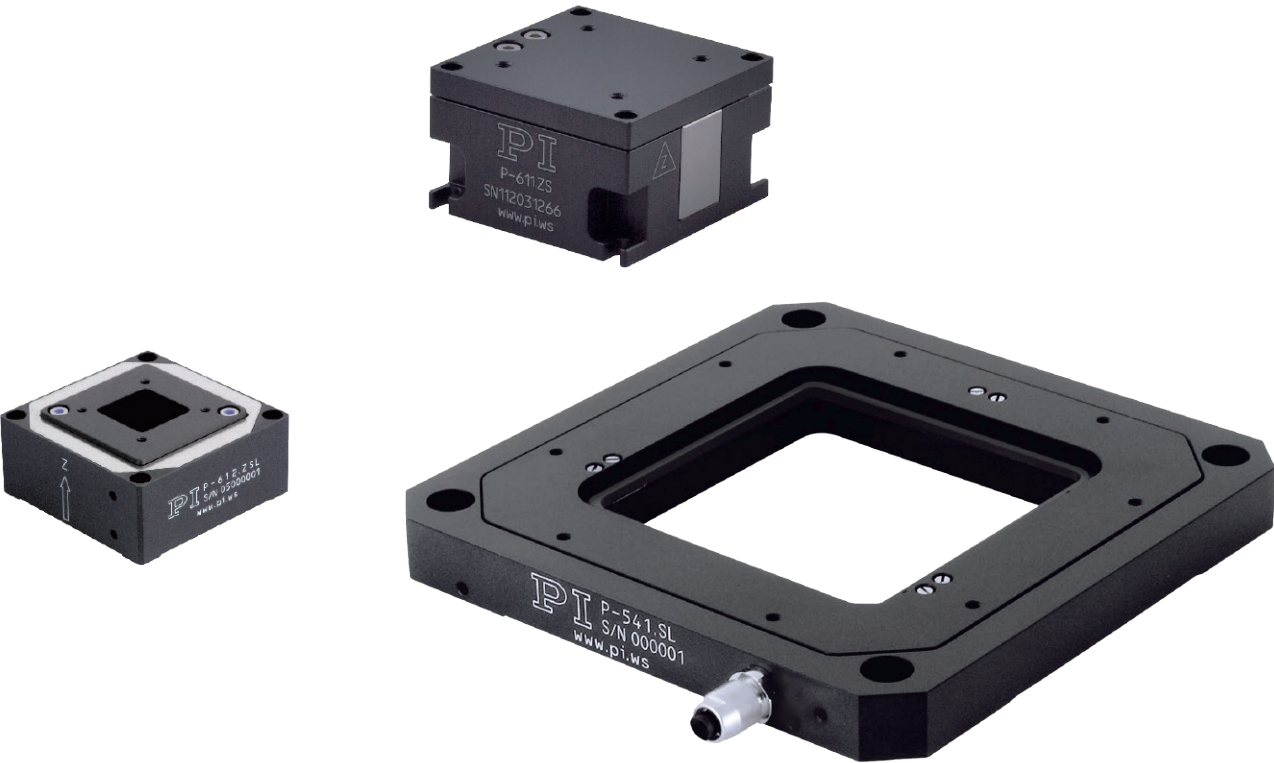

Linear Stages	22
P-620.1 / P-629.1 PIHera Piezo Linear Stage System	24
P-611.1 Linear Piezo Positioning System	26
P-630 High-Dynamics Nanopositioning System	28
P-752 High Precision Nanopositioning Stage	30
P-753 LISA Linear Actuator & Stage	32
<hr/>	
Vertical Stages	34
P-620.Z / P-622.Z PIHera Precision Z-Stage	34
P-612.Z Piezo Z Stage	36
P-611.Z Piezo Z Stage	38
P-733.Z High-Dynamics Z-Nanopositioner / Scanner	40
S-303 Piezo Phase Shifter	42
<hr/>	
XY Stages	44
P-620.2 / P-629.2 PIHera XY Piezo Stage	44
P-611.XZ / P-611.2 XZ & XY Nanopositioner	46
P-541.2 / P-542.2 XY Piezo Stage	48
P-612.2 XY Piezo Nanopositioning System	50
P-733.2 XY Piezo Nanopositioner	52
<hr/>	
Multi-Axis Stages	54
P-616 NanoCube® Nanopositioner	54
P-611.3 NanoCube® XYZ Piezo Stage	56
P-313 PicoCube XY(Z) Piezo Scanner	58
P-363 PicoCube XY(Z) Piezo Scanner	60
P-733.3 XYZ Piezo Nanopositioner	62
P-561 / P-562 / P-563 PIMars Nanopositioning Stage	64
P-517 / P-527 Multi-Axis Piezo Scanner	66
P-518 / P-528 / P-558 Piezo Z / Tip / Tilt Stage	68
P-541.Z Piezo Z and Z / Tip / Tilt Stages	70
P-562.6CD PIMars 6-Axis Piezo Stage System	72
P-587 6-Axis Precision Piezo Stage	74

P-620.1 / P-629.1 PIHera Piezo Linear Stage System

Variable Travel Ranges and Axis Configuration

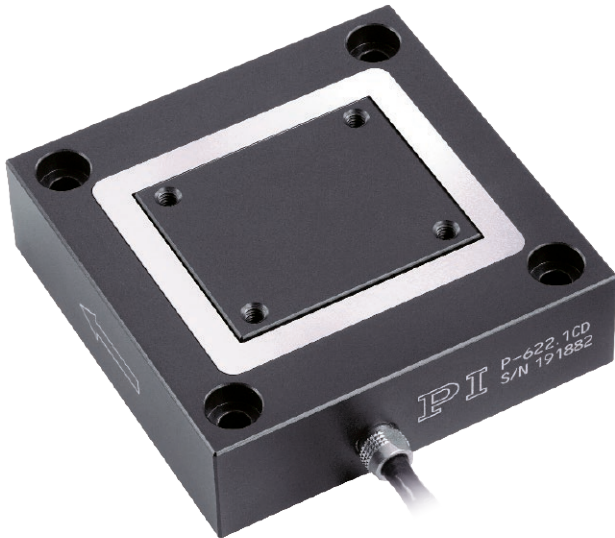

- Travel ranges 50 to 1800 μm
- Resolution to 0.1 nm
- Linearity error 0.02 %
- Direct metrology with capacitive sensors
- X, XY, Z, XYZ versions

P-62x.1CD / .1CL / .10L / .1UD, dimensions in mm.

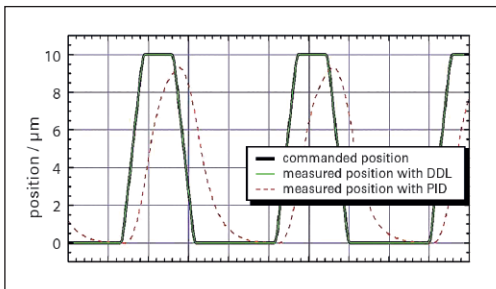
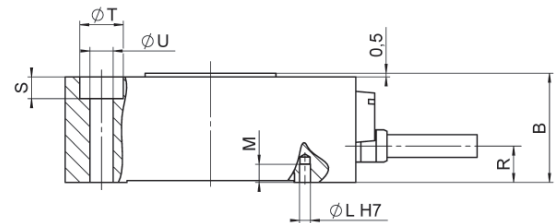

Rapid scanning motion of a P-621.1CD (commanded rise time 5 ms) with the E-710 controller and Digital Dynamic Linearization (DDL) option. DDL virtually eliminates the tracking error (<20 nm) during the scan. The improvement over a classical PID controller is up to 3 orders of magnitude, and increases with the scanning frequency.

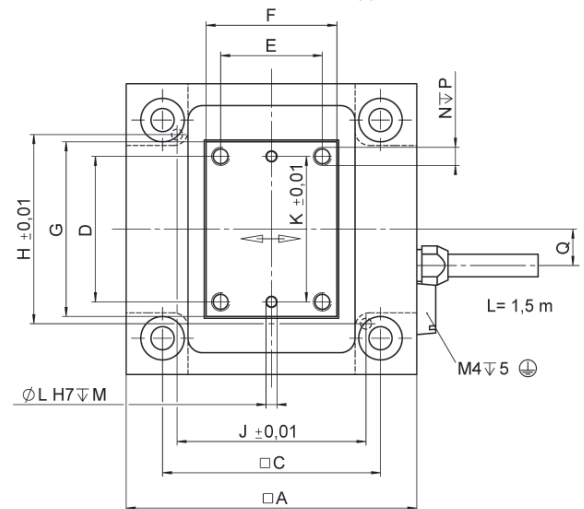

	A	B	C	D	E	F	G	H	J	K	ØL	M	N	P	Q	R	S	ØT	ØU
P-620.1CD / 10L	30	12	24	15	30	15	18	19	24	15	1,01	1,5	M2	4	4,5	6	2	4,4	2,2
P-621.1CD / 10L	40	15	30	20	40	18	24	26	26	20	1,51	2,5	M2,5	5	5	5	3	6	3,2
P-622.1CD / 10L	50	15	40	24	50	25	30	35	35	24	1,51	2,5	M2,5	5	5,5	5	3	6	3,2
P-625.1CD / 10L	60	15	50	40	60	32	44,5	46	46	40	1,51	2,5	M2,5	5	5,5	5	15	6	3,2
P-628.1CD / 10L	80	17	70	58	80	45	63	66	66	58	1,51	2,5	M2,5	5	5,5	5	3	6	3,2
P-629.1CD / 10L	100	22,5	90	60	100	60	84	82	82	60	2,01	3,5	M2,5	5	10	7,5	4	8	4,2

Applications

- Interferometry
- Microscopy
- Nanopositioning
- Biotechnology
- Testing
- Semiconductor technology
- Photonics
- Fiber positioning

- >> Capacitive Feedback Sensors
- >> Direct Metrology
- >> Flexure Guiding Systems
- >> PICMA® Multilayer Piezo Actuators
- >> Vacuum-Compatible Version

Technology Glossary page 240

	P-620.1CD / P-620.1CL	P-621.1CD / P-621.1CL	P-622.1CD / P-622.1CL	P-625.1CD / P-625.1CL	P-628.1CD / P-628.1CL	P-629.1CD / P-629.1CL	Unit	Tolerance
Active axes	X	X	X	X	X	X		
Motion and positioning								
Integrated sensor	Capacitive	Capacitive	Capacitive	Capacitive	Capacitive	Capacitive		
Open-loop travel range, -20 to 120 V	60	120	300	600	950	1800	µm	+20 % / -0 %
Closed-loop travel range	50	100	250	500	800	1500	µm	
Closed-loop / open-loop resolution	0.2 / 0.1	0.4 / 0.2	0.7 / 0.4	1.4 / 0.5	1.8 / 0.5	3 / 2	nm	typ.
Linearity error, closed-loop	0.02	0.02	0.02	0.03	0.03*	0.03**	%	typ.
Repeatability	±1	±1	±1	±5	±10	±14	nm	typ.
Pitch / yaw	±3	±3	±3	±6	±6	±30 / ±10	µrad	typ.
Mechanical properties								
Stiffness in motion direction	0.42	0.35	0.2	0.1	0.12	0.13	N/µm	±20 %
Resonant frequency, no load	1100	800	400	215	125	125	Hz	±20 %
Resonant frequency, under load, 20 g	550	520	340	180	115	120	Hz	±20 %
Resonant frequency, under load, 120 g	260	240	185	110	90	110	Hz	±20 %
Compressive / tensile stress capacity in motion direction	10	10	10	10	10	10	N	max.
Load capacity	10	10	10	10	10	10	N	max.
Lateral force	10	10	10	10	10	8	N	max.
Drive properties								
Piezo ceramic	PICMA® P-883	PICMA® P-885	PICMA® P-885	PICMA® P-885	PICMA® P-887	PICMA® P-888		
Electrical capacitance	0.35	1.5	3.1	6.2	19	52	µF	±20 %
Miscellaneous								
Operating temperature range	-20 to 80	-20 to 80	-20 to 80	-20 to 80	-20 to 80	-20 to 80	°C	
Material	Aluminum	Aluminum	Aluminum	Aluminum	Aluminum	Aluminum		
Dimensions	30 mm × 30 mm × 12 mm	40 mm × 40 mm × 15 mm	50 mm × 50 mm × 15 mm	60 mm × 60 mm × 15 mm	80 mm × 80 mm × 17 mm	100 mm × 100 mm × 22.5 mm		
Mass	0.11	0.16	0.2	0.24	0.38	0.72	kg	±5 %
Cable length	1.5	1.5	1.5	1.5	1.5	1.5	m	±10 mm
Sensor / voltage connection	CD versions: Sub-D 7W2 CL versions: LEMO	CD versions: Sub-D 7W2 CL versions: LEMO	CD versions: Sub-D 7W2 CL versions: LEMO	CD versions: Sub-D 7W2 CL versions: LEMO	CD versions: Sub-D 7W2 CL versions: LEMO	CD versions: Sub-D 7W2 CL versions: LEMO		
Recommended electronics	E-503, E-505, E-610, E-621, E-625, E-665, E-709, E-754	E-503, E-505, E-610, E-621, E-625, E-665, E-709, E-754	E-503, E-505, E-610, E-621, E-625, E-665, E-709, E-754	E-503, E-505, E-610, E-621, E-625, E-665, E-709, E-754	E-503, E-505, E-610, E-621, E-625, E-665, E-709, E-754	E-503, E-505, E-610, E-621, E-625, E-665, E-709, E-754		

Versions without sensor are available under the P-62x.10L ordering number; operating temperature range -20 to 150 °C. Sensor / voltage connection LEMO.

Vacuum versions to 10⁻⁵ hPa are available as P-62x.1UD.

The resolution of PI piezo nanopositioners is not limited by friction or stiction. Value given as noise with E-710 digital controller.

* With digital controller. With analog controllers 0.05 %

** With digital controller. With analog controllers 0.08 %

All specifications based on room temperature (22 °C ±3 °C).

P-611.1 Linear Piezo Positioning System

Cost-Effective, Compact Linear Positioning System

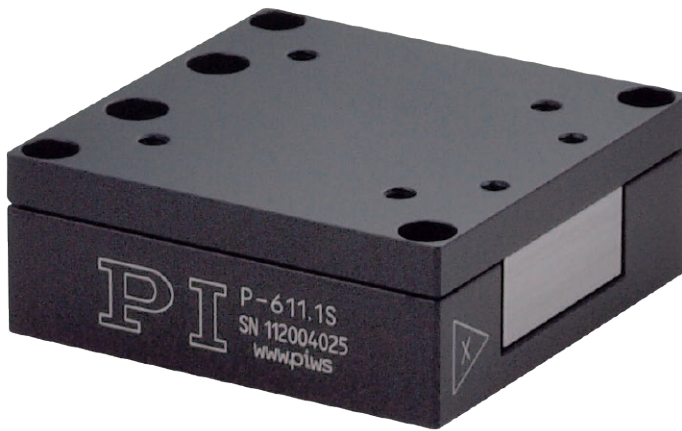

- Compact design: Footprint 44 mm × 44 mm
- Travel range 120 μm
- Resolution to 0.2 nm
- Cost-effective mechanics / electronics system configurations
- Outstanding lifetime due to PICMA® piezo actuators
- Z stage, XY, XZ and XYZ versions available

P-611.2S, dimensions in mm.

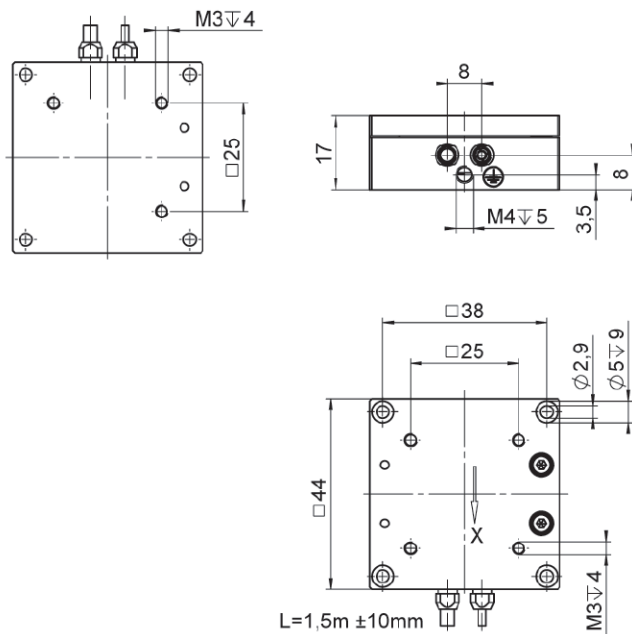

P-611.1S repeatability equals 2.7 nm

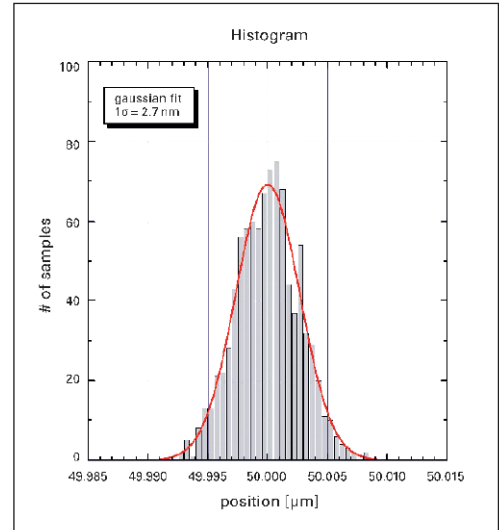

Applications

- Microscopy
- Nanopositioning
- Biotechnology
- Testing
- Semiconductor technology
- Photonics
- Fiber positioning

- >> Flexure Guiding Systems
- >> PICMA® Multilayer Piezo Actuators

Technology Glossary page 240

	P-611.1S	P-611.10	Unit	Tolerance
Active axes	X	X		
Motion and positioning				
Integrated sensor	SGS	–		
Open-loop travel, –20 to +120 V	120	120	µm	+20 % / –0 %
Closed-loop travel	100	–	µm	
Open-loop resolution	0.2	0.2	nm	typ.
Closed-loop resolution	2	–	nm	typ.
Linearity error, closed-loop	0.1	–	%	typ.
Repeatability	<10	–	nm	typ.
Pitch	±5	±5	µrad	typ.
Yaw	±20	±20	µrad	typ.
Flatness	10	10	nm	typ.
Mechanical properties				
Stiffness in motion direction	0.2	0.2	N/µm	±20 %
Unloaded resonant frequency	400	400	Hz	±20 %
Resonant frequency at 30 g	300	300	Hz	±20 %
Resonant frequency at 100 g	195	195	Hz	±20 %
Push / pull force capacity in motion direction	15 / 10	15 / 10	N	max.
Load capacity	15	15	N	max.
Drive properties				
Ceramic type	PICMA® P-885	PICMA® P-885		
Electrical capacitance	1.5	1.5	µF	±20 %
Miscellaneous				
Operating temperature range	–20 to 80	–20 to 80	°C	
Material	Aluminum, steel	Aluminum, steel		
Dimensions	44 mm × 44 mm × 17 mm	44 mm × 44 mm × 17 mm		
Mass	0.135	0.135	kg	±5 %
Cable length	1.5	1.5	m	±10 mm
Voltage connection	LEMO	LEMO		
Sensor connection	LEMO	–		
Recommended electronics	E-503, E-505, E-610, E-621, E-625, E-665, E-836	E-503, E-505, E-610, E-621, E-625, E-665, E-836		

The resolution of PI piezo nanopositioners is not limited by friction or stiction. Noise equivalent motion with E-503 amplifier.

All specifications based on room temperature (22 °C ±3 °C).

Ask about custom designs!

P-630 High-Dynamics Nanopositioning System

1 Axis with Large Clear Aperture



- Resonant frequency to 3.25 kHz
- Travel ranges to 80 μm
- Small footprint and low-profile height
- Clear aperture with 30 mm diameter

P-630, dimensions in mm.

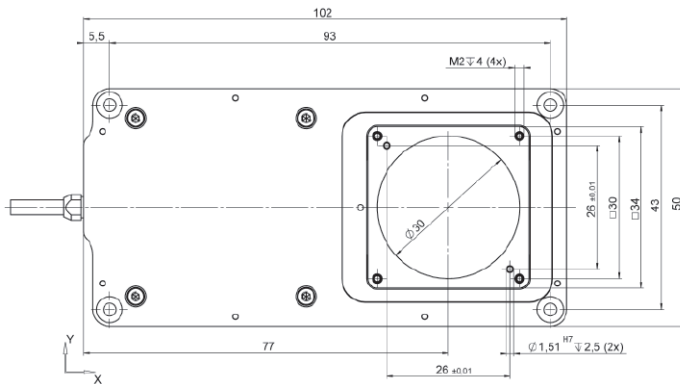
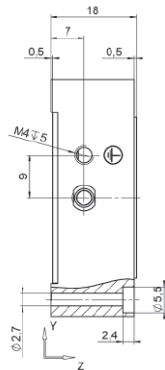

The smallest resolvable step size of P-630.XCD with E-753.1CD digital controller is below one nm. Measured externally with a laser interferometer.

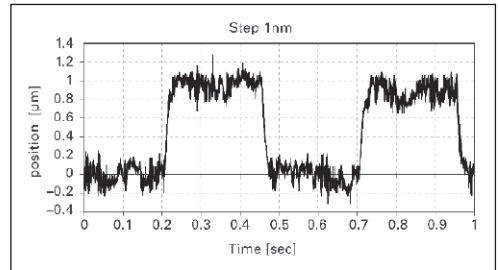

The settling time for P-630.XCD is less than 6 ms with 1% accuracy and a 4 μm step.

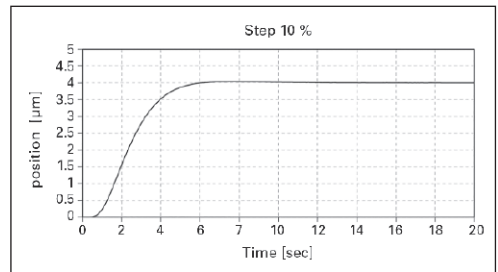

Applications

- Optical alignment
- Microscopy
- Biotechnology
- Photonics
- Fiber positioning

- >> Capacitive Feedback Sensors
- >> Direct Metrology
- >> Flexure Guiding Systems
- >> PICMA® Multilayer Piezo Actuators
- >> Vacuum-Compatible Version

Technology Glossary page 240

	P-630.XCD	P-631.XCD	Unit
Active axes	X	X	
Motion and positioning			
Integrated sensor	Capacitive	Capacitive	
Open-loop travel, -20 to 120 V	45	90	µm
Closed-loop travel	40	80	µm
Open-loop resolution	0.1	0.1	nm
Closed-loop resolution	0.2	0.2	nm
Closed-loop nonlinearity	0.02	0.02	%
Repeatability over the entire travel range	±2	±3	nm
Pitch / yaw	±5	±5	µrad
Straightness / flatness	50	50	nm
Mechanical properties			
Stiffness in motion direction	5.5	5	N / µm
Unloaded resonant frequency	3250	2850	Hz
Resonant frequency at 60 g	1600	1200	Hz
Push / pull force capacity in motion direction	10	10	N
Load capacity	10	10	N
Drive properties			
Piezo ceramic	PICMA® P-887	PICMA® P-885; P-887	
Electrical capacitance	6.4	12.6	µF
Miscellaneous			
Operating temperature range	0 to 40	0 to 40	°C
Material	Aluminum	Aluminum	
Dimensions	102 mm × 50 mm × 18 mm	102 mm × 50 mm × 18 mm	
Mass	300	320	g
Cable length	1.5	1.5	m
Sensor / voltage connection	Sub-D 7W2 (m)	Sub-D 7W2 (m)	
Recommended electronics	E-709, E-709.CHG, E-754	E-709, E-709.CHG, E-754	

All specifications based on room temperature (22 °C ±3 °C).

P-752 High Precision Nanopositioning Stage

High-Dynamics, Very Stable Piezo Scanner with Extreme Guiding Accuracy

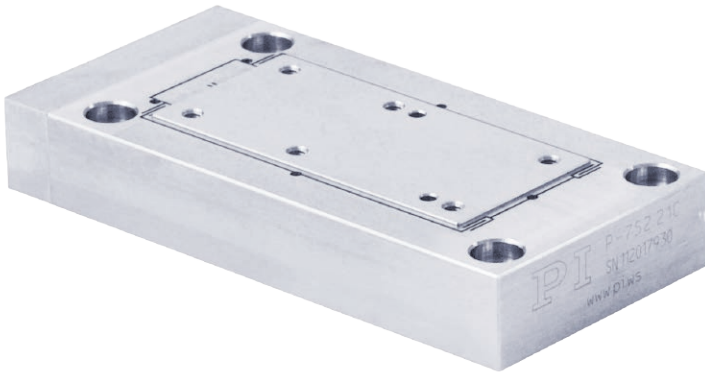

- Resolution 0.1 nm
- Rapid response
- Travel range to 35 μm
- Highest linearity due to capacitive sensors
- Frictionless flexure guides for very high travel accuracy
- Outstanding lifetime due to PICMA[®] piezo actuators

P-752.2xx, dimensions in mm.

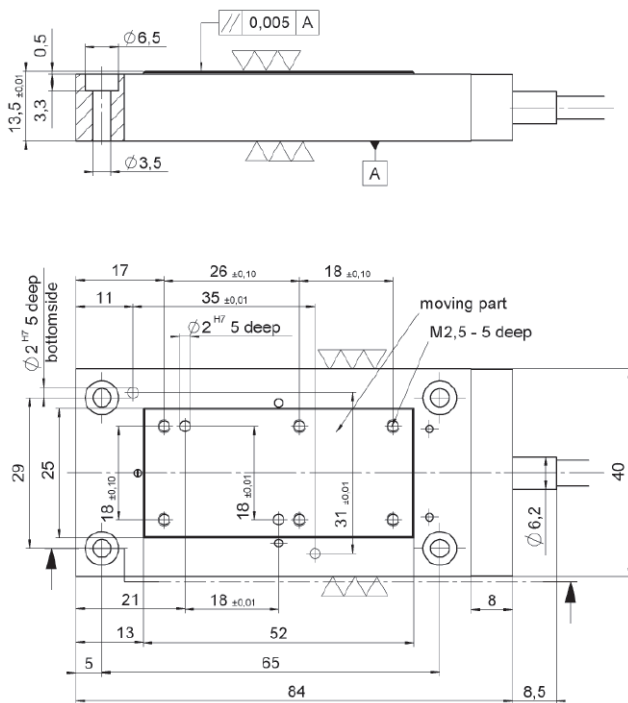

P-752.1xx, dimensions in mm.

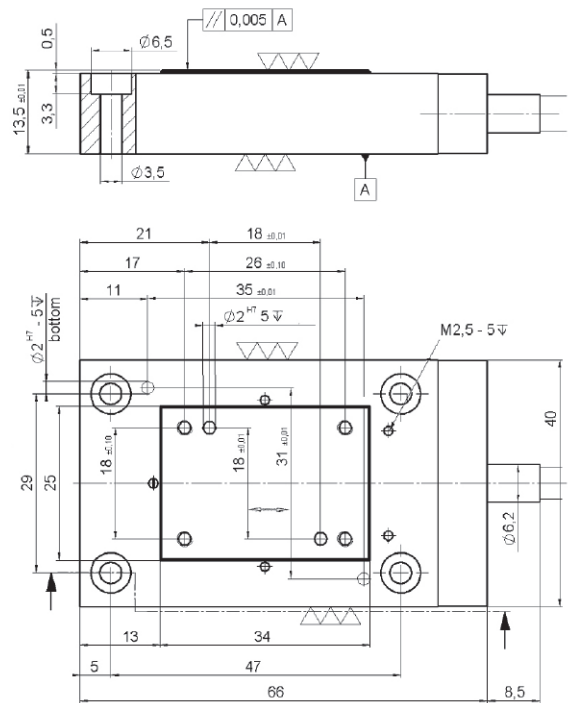

Applications

- Scanning microscopy
- Metrology
- Testing and quality processes
- Photonics
- Fiber positioning

- >> Capacitive Feedback Sensors
- >> Direct Metrology
- >> Flexure Guiding Systems
- >> PICMA[®] Multilayer Piezo Actuators

Technology Glossary page 240

	P-752.11C	P-752.1CD	P-752.21C	P-752.2CD	Units	Tolerance
Active axes	X	X	X	X		
Motion and positioning						
Integrated sensor	Capacitive	Capacitive	Capacitive	Capacitive		
Open-loop travel, -20 to +120 V	20	20	35	35	μm	+20 % / -0 %
Closed-loop travel	15	15	30	30	μm	
Closed-loop / open-loop resolution	0.1	0.1	0.2	0.2	nm	typ.
Closed-loop linearity error	0.03	0.03	0.03	0.03	%	typ.
Repeatability	±1	±1	±2	±2	nm	typ., full travel
Pitch / yaw	±1	±1	±1	±1	μrad	typ.
Mechanical properties						
Stiffness in motion direction	30	30	20	20	N/μm	±20 %
Unloaded resonant frequency	3200	3200	2100	2100	Hz	±20 %
Resonant frequency at 300 g	980	980	600	600	Hz	±20 %
Push / pull force capacity in motion direction	100 / 10	100 / 10	100 / 10	100 / 10	N	max.
Load capacity	30	30	30	30	N	max.
Drive properties						
Ceramic type	PICMA® P-885	PICMA® P-885	PICMA® P-885	PICMA® P-885		
Electrical capacitance	2.1	2.1	3.7	3.7	μF	±20 %
Miscellaneous						
Operating temperature range	-20 to 80	-20 to 80	-20 to 80	-20 to 80	°C	
Material	Steel	Steel	Steel	Steel		
Dimensions	66 mm x 40 mm x 13.5 mm	66 mm x 40 mm x 13.5 mm	84 mm x 40 mm x 13.5 mm	84 mm x 40 mm x 13.5 mm		
Mass	0.25	0.25	0.35	0.35	kg	±5 %
Cable length	1.5	1.5	1.5	1.5	m	±10 mm
Sensor / voltage connection	LEMO	Sub-D 7W2 (m)	LEMO	Sub-D 7W2 (m)		
Recommended electronics	E-505, E-610, E-625, E-665, E-754	E-505, E-610, E-625, E-665, E-754	E-505, E-610, E-625, E-665, E-754	E-505, E-610, E-625, E-665, E-754		

The resolution of PI piezo nanopositioners is not limited by friction or stiction. Value given is noise equivalent motion with E-503 amplifier.
All specifications based on room temperature (22 °C ±3 °C).
Ask about custom designs!

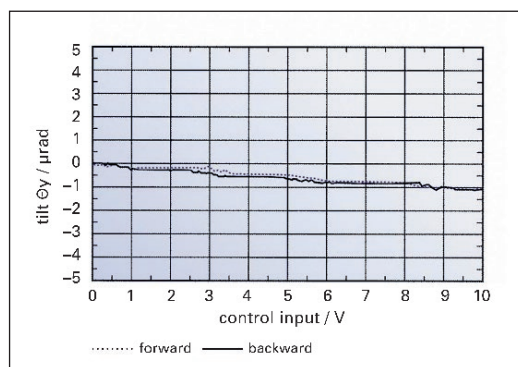

Typical 0.5 μrad bidirectional trajectory repeatability (P-752.11C stage) means processes may be performed bidirectionally for twice the productivity.

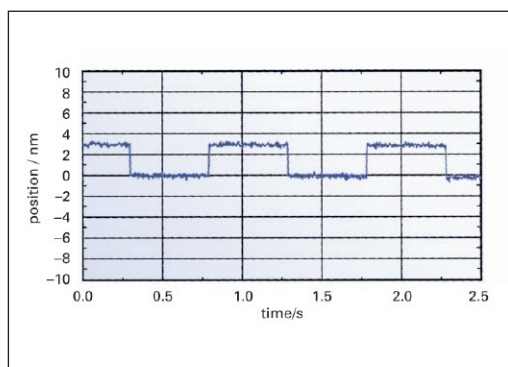

Response of a P-752.11C to a square wave control signal with 3 nm amplitude shows true sub-nm positional stability, incremental motion and bidirectional repeatability (measured with E-501 & E-503.00 & E-509.C1 controller, bandwidth set to 240 Hz).

P-753 LISA Linear Actuator & Stage

High-Dynamics, Very Stable Piezo Nanopositioner

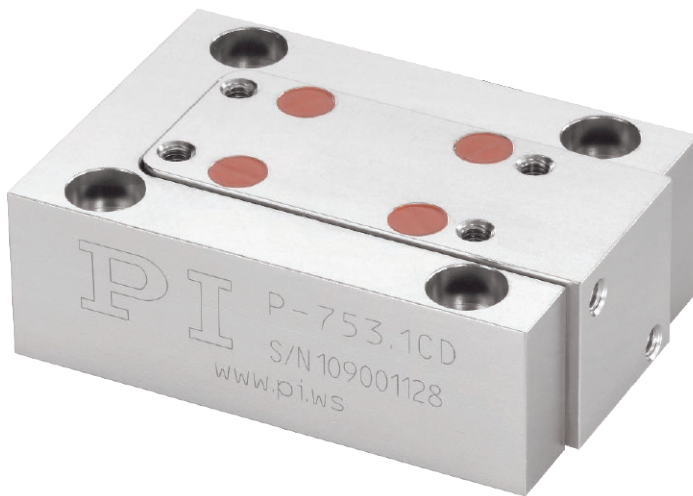

- Versatile design: Flexure stage or actuator
- Travel range to 38 μm
- Resolution 0.05 nm
- Non-magnetic versions available
- Direct-drive design for fastest response
- Highest linearity due to capacitive sensors

P-753.1, dimensions in mm.
Max. torque at M2.5 threads: 0.3 Nm.

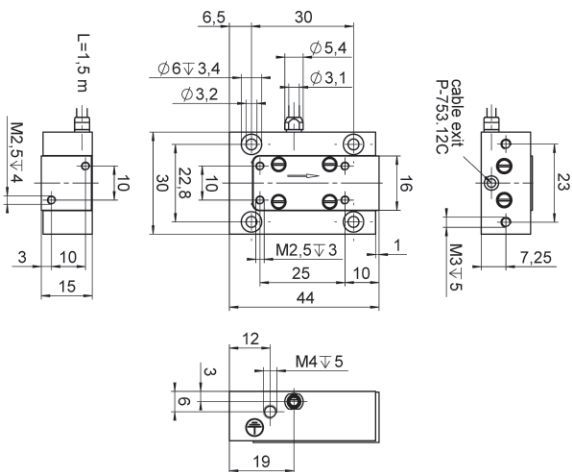

P-753.2, dimensions in mm.
Max. torque at M2.5 threads: 0.3 Nm.

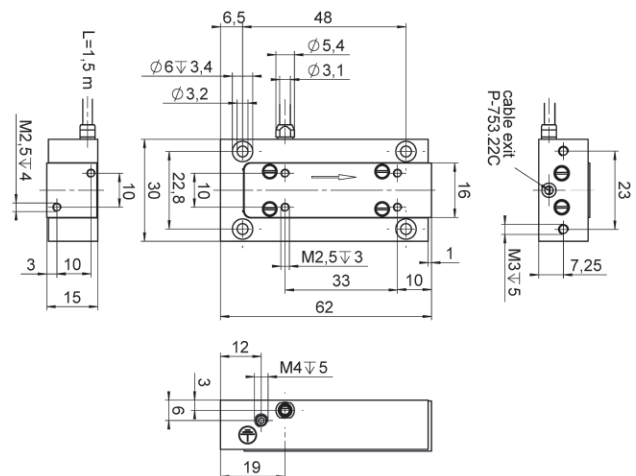

Applications

- Scanning microscopy
- Metrology
- Testing and quality processes
- Photonics
- Fiber positioning

- >> Capacitive Feedback Sensors
- >> Direct Metrology
- >> Flexure Guiding Systems
- >> PICMA® Multilayer Piezo Actuators
- >> Vacuum-Compatible Version

Technology Glossary page 240

	P-753.1CD	P-753.2CD	P-753.3CD	Unit	Tolerance
Active axes	X	X	X		
Motion and positioning					
Integrated sensor	Capacitive	Capacitive	Capacitive		
Closed-loop travel	12	25	38	µm	
Closed-loop / open-loop resolution	0.05	0.1	0.2	nm	typ., full travel
Linearity error, closed-loop	0.03	0.03	0.03	%	typ.
Repeatability	±1	±2	±3	nm	typ.
Pitch / yaw	±5	±7	±10	µrad	typ.
Mechanical properties					
Stiffness in motion direction	45	24	16	N/µm	±20 %
Unloaded resonant frequency	5.6	3.7	2.9	kHz	±20 %
Resonant frequency at 200 g	2.5	1.7	1.4	kHz	±20 %
Push / pull force capacity in motion direction	100 / 20	100 / 20	100 / 20	N	max.
Load capacity (vertical / horizontal mounting)	10 / 2	10 / 2	10 / 2	kg	max.
Drive properties					
Ceramic type	PICMA® P-885	PICMA® P-885	PICMA® P-885		
Electrical capacitance	1.5	3.1	4.6	µF	±20 %
Miscellaneous					
Operating temperature range	-20 to 80	-20 to 80	-20 to 80	°C	
Material	Steel	Steel	Steel		
Dimensions	44 mm × 30 mm × 15 mm	62 mm × 30 mm × 15 mm	80 mm × 30 mm × 15 mm		
Mass	0.16	0.215	0.26	kg	±5 %
Cable length	1.5	1.5	1.5	m	±10 mm
Sensor / voltage connection	Sub-D 7W2 (m)	Sub-D 7W2 (m)	Sub-D 7W2 (m)		
Recommended electronics	E-625	E-625	E-625		

The resolution of PI piezo nanopositioning systems is not limited by friction or stiction. Value given is noise-equivalent motion with the E-503 piezo amplifier module. Versions with LEMO connector available as P-753.x1C. Vacuum versions to 10⁻⁹ hPa are available under the following ordering number: P-753.xUD. No-magnetic versions available as P-753.xND. All specifications based on room temperature (22 °C ±3 °C).

P-753.3, dimensions in mm.
Max. torque at M2.5 threads: 0.3 Nm.

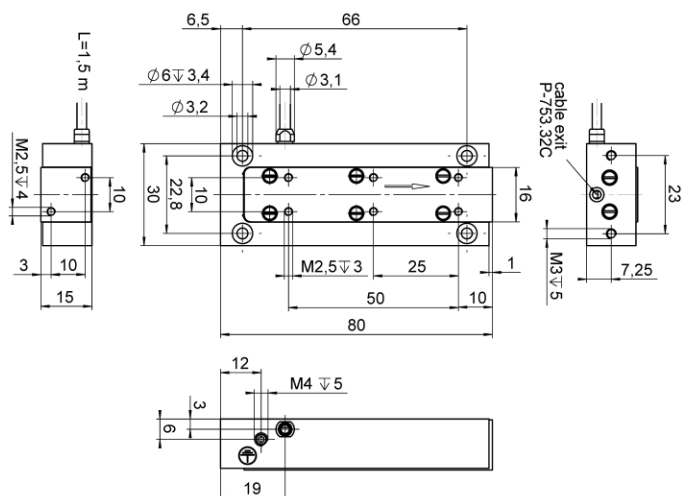

P-620.Z / P-622.Z PIHera Precision Z-Stage

Variable Travel Ranges and Axis Configuration



- Travel ranges 50 μm to 250 μm (400 μm open-loop)
- Resolution to 0.1 nm
- Positioning accuracy 0.02 %
- Direct metrology with capacitive sensors
- X, XY, Z, XYZ versions

P-62x.ZCD / .ZCL / .ZOL, dimensions in mm.

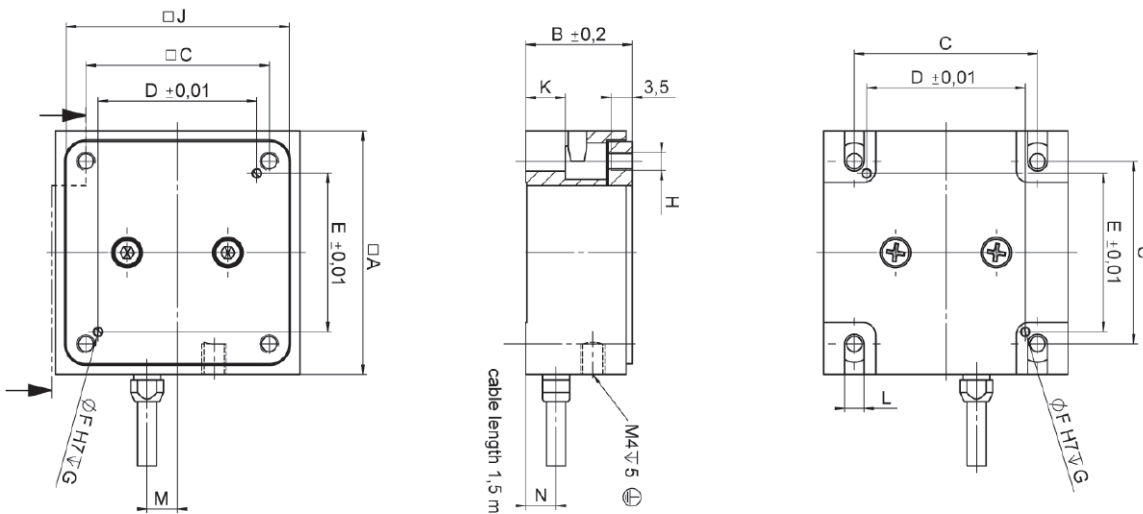

	A	B	C	D	E	ØF	G	H	J	K	L	M	N
P-620.ZCD / ZOL	30	12	24	19	24	1,01	2	M2	28	5	2,2	4,5	6
P-621.ZCD / ZOL	40	17,5	30	26	26	1,51	2,5	M3	36,5	6,5	3,2	5	5
P-622.ZCD / ZOL	50	17,5	40	35	35	1,51	2,5	M3	46,5	6,5	3,2	5	5

Applications

- Interferometry
- Microscopy
- Nanopositioning
- Biotechnology
- Testing and quality processes
- Semiconductor technology

- >> Capacitive Feedback Sensors
- >> Direct Metrology
- >> Flexure Guiding Systems
- >> PICMA® Multilayer Piezo Actuators
- >> Vacuum-Compatible Version

Technology Glossary page 240

	P-620.ZCD / P-620.ZCL	P-621.ZCD / P-621.ZCL	P-622.ZCD / P-622.ZCL	Unit	Tolerance
Active axes	Z	Z	Z		
Motion and positioning					
Integrated sensor	Capacitive	Capacitive	Capacitive		
Open-loop travel range, –20 to 120 V	65	140	400	µm	+20 % / –0 %
Closed-loop travel range	50	100	250	µm	
Open-loop resolution	0.1	0.2	0.5	nm	typ.
Closed-loop resolution	0.2	0.3	1	nm	typ.
Linearity error	0.02	0.02	0.02	%	typ.
Repeatability	±1	±1	±1	nm	typ.
Tilt θ_x, θ_y	<20	<20	<80	µrad	typ.
Mechanical properties					
Stiffness	0.5	0.6	0.24	N/µm	±20 %
Resonant frequency, no load	1000	790	360	Hz	±20 %
Resonant frequency, under load, 30 g	690	500	270	Hz	±20 %
Compressive / tensile stress capacity	10 / 5	10 / 8	10 / 8	N	max.
Load capacity	10	10	10	N	max.
Lateral force	10	10	10	N	max.
Drive properties					
Ceramic type	PICMA® P-883	PICMA® P-885	PICMA® P-885		
Electrical capacitance	0.7	3	6.2	µF	±20 %
Miscellaneous					
Operating temperature range	–20 to 80	–20 to 80	–20 to 80	°C	
Material	Aluminum	Aluminum	Aluminum		
Dimensions	30 mm × 30 mm × 15 mm	40 mm × 40 mm × 17.5 mm	50 mm × 50 mm × 17.5 mm		
Mass	0.12	0.17	0.24	kg	±5 %
Cable length	1.5	1.5	1.5	m	±10 mm
Sensor / voltage connection	CD versions: Sub D 7W2 (m) CL versions: LEMO	CD versions: Sub D 7W2 (m) CL versions: LEMO	CD versions: Sub D 7W2 (m) CL versions: LEMO		
Recommended electronics	E-503, E-505, E 610, E-621, E 625, E-665, E-709, E-754	E-503, E-505, E 610, E-621, E 625, E-665, E-709, E-754	E-503, E-505, E 610, E-621, E 625, E-665, E-709, E-754		

Versions without sensor are available as P-62x.Z0L; operating temperature range –20 to 150 °C. Voltage connection LEMO.
All specifications based on room temperature (22 °C ±3 °C).

P-612.Z Piezo Z Stage

Compact Nanopositioning Stage with Aperture

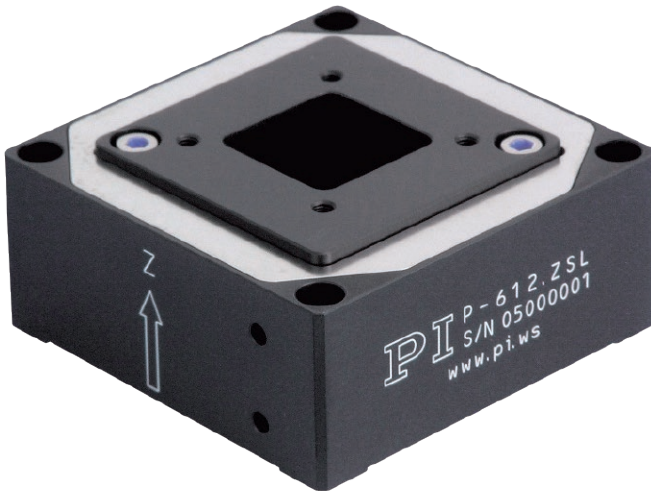

P-612.Z, dimensions in mm.

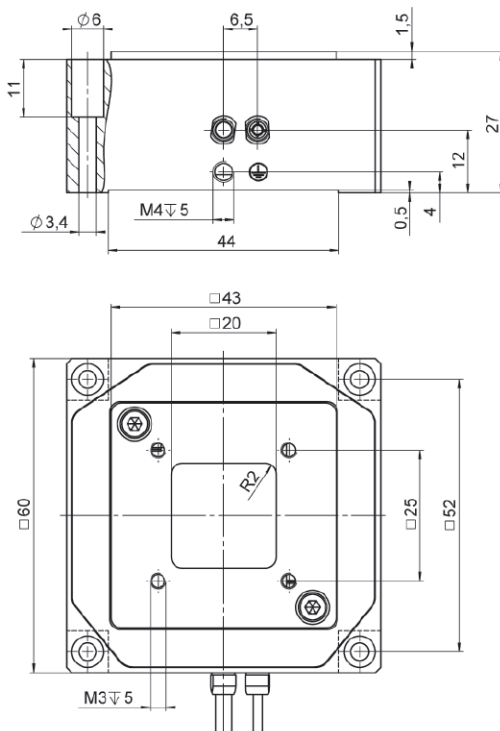

- Travel range 100 μm
- Resolution to 0.2 nm
- Linearity error 0.2 %
- Compact: Footprint 60 mm x 60 mm
- Very cost-effective controller / piezomechanics systems
- Zero-play, high-precision flexure guide system
- Outstanding lifetime due to PICMA[®] piezo actuators

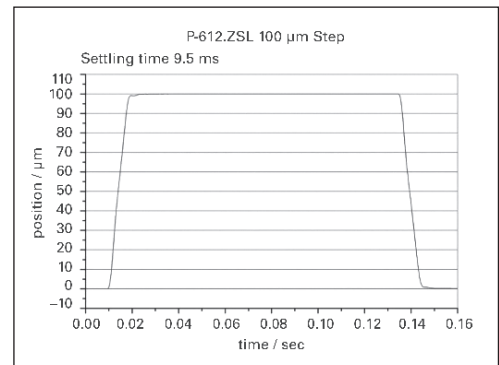

Settling takes less than 10 ms over the entire travel range in closed-loop operation.

Applications

- Interferometry
- Microscopy
- Nanopositioning
- Biotechnology
- Testing and quality processes
- Semiconductor technology

- >> Flexure Guiding Systems
- >> PICMA[®] Multilayer Piezo Actuators

Technology Glossary page 240

	P-612.ZSL	P-612.Z0L	Unit	Tolerance
Active axes	Z	Z		
Motion and positioning				
Integrated sensor	SGS	–		
Open-loop travel, –20 to +120 V	110	110	µm	+20 % / –0 %
Closed-loop travel range	100	–	µm	
Open-loop resolution	0.2	0.2	nm	typ.
Closed-loop resolution	1.5	–	nm	typ.
Linearity error, closed-loop	0.2	–	%	typ.
Repeatability	±4	–	nm	typ.
Runout θ_x, θ_y	±10	±10	µrad	typ.
Crosstalk in X, Y	±20	±20	µm	typ.
Mechanical properties				
Stiffness in motion direction	0.63	0.63	N/µm	±20 %
Resonant frequency, no load	490	490	Hz	±20 %
Resonant frequency under load	420 (30 g)	420 (30 g)	Hz	±20 %
Load capacity	15 / 10	15 / 10	N	max.
Drive properties				
Ceramic type	PICMA® P-885	PICMA® P-885		
Electrical capacitance	3	3	µF	±20 %
Miscellaneous				
Operating temperature range	–20 to 80	–20 to 80	°C	
Material	Aluminum	Aluminum		
Mass	0.28	0.275	kg	±5 %
Cable length	1.5	1.5	m	±10 mm
Sensor / voltage connection	LEMO	LEMO (no sensor)		
Recommended electronics	E-610, E-621, E-625, E-665	E-610, E-621, E-625, E-665		

The resolution of PI piezo nanopositioners is not limited by friction or stiction. Value given is noise equivalent motion with E-503 amplifier.
All specifications based on room temperature (22 °C ±3 °C).

P-611.Z Piezo Z Stage

Compact Nanopositioner



- Compact: Footprint only 44 mm x 44 mm
- Travel range 100 μm
- Resolution to 0.2 nm
- Cost-effective mechanics / electronics system configurations
- Zero-play, high-precision flexure guide system
- Outstanding lifetime due to PICMA[®] piezo actuators
- X, XY, XZ and XYZ versions

P-611.ZS, dimensions in mm.

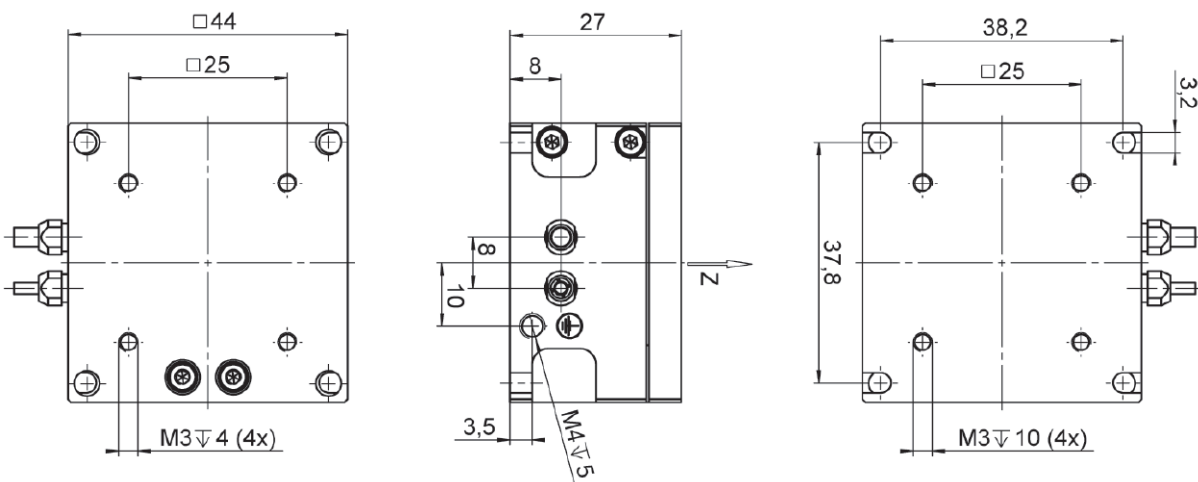

Applications

- Micromachining
- Photonics
- Fiber positioning
- Testing and quality processes
- Photonics
- Fiber positioning

- >> Flexure Guiding Systems
- >> PICMA[®] Multilayer Piezo Actuators

Technology Glossary page 240

	P-611.ZS	P-611.Z0	Unit	Tolerance
Active axes	Z	Z		
Motion and positioning				
Integrated sensor	SGS	–		
Open-loop travel, –20 to +120 V	120	120	µm	+20 % / –0 %
Closed-loop travel	100	–	µm	
Open-loop resolution	0.2	0.2	nm	typ.
Closed-loop resolution	2	–	nm	typ.
Linearity error	0.1	–	%	typ.
Repeatability	<10	–	nm	typ.
Runout θ_z (Z motion)	±5	±5	µrad	typ.
Runout θ_x (Z motion)	±20	±20	µrad	typ.
Runout θ_y (Z motion)	±5	±5	µrad	typ.
Mechanical properties				
Stiffness	0.45	0.45	N/µm	±20 %
Unloaded resonant frequency	460	460	Hz	±20 %
Resonant frequency at 30 g	375	375	Hz	±20 %
Resonant frequency at 100 g	265	265	Hz	±20 %
Push / pull force capacity	15 / 10	15 / 10	N	max.
Drive properties				
Ceramic type	PICMA® P-885	PICMA® P-885		
Electrical capacitance	1.5	1.5	µF	±20 %
Miscellaneous				
Operating temperature range	–20 to 80	–20 to 80	°C	
Material	Aluminum, steel	Aluminum, steel		
Dimensions	44 mm × 44 mm × 27 mm	44 mm × 44 mm × 27 mm		
Mass	176	176	g	±5 %
Cable length	1.5	1.5	m	±10 mm
Sensor connection	LEMO	LEMO		
Voltage connection	LEMO	LEMO		
Recommended electronics	E-610, E-625, E-665, E-836	E-610, E-625, E-665, E-836		

All specifications based on room temperature (22 °C ±3 °C).

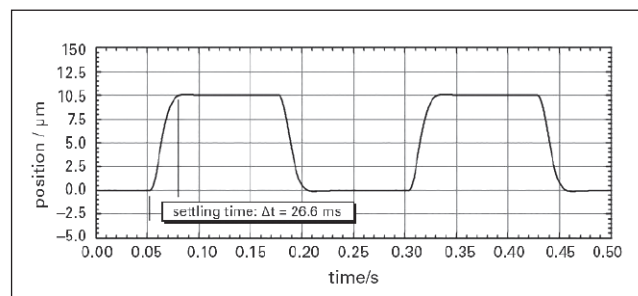

The settling time of a P-611.Z with a load of 30 g is 26 ms for a 10 µm step. Measured with interferometer.

P-733.Z High-Dynamics Z-Nanopositioner / Scanner

Direct Position Metrology and Clear Aperture



- Travel range 100 μm
- Direct metrology with capacitive sensors
- Resolution to 0.3 nm, closed-loop
- Clear aperture 50 mm \times 50 mm
- Versions with additional degrees of freedom available
- XY and XYZ versions also available
- Vacuum-compatible versions available

P-733.Z, dimensions in mm.

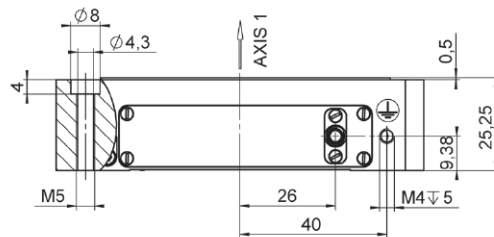
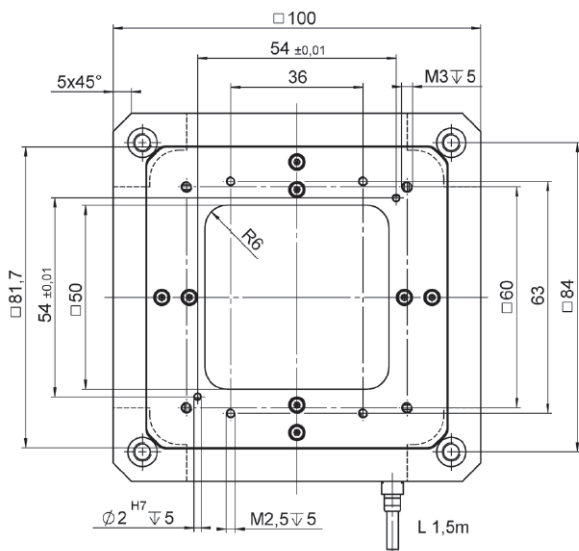

Applications

- Scanning microscopy
- Confocal microscopy
- Mask / wafer positioning
- Surface measurement technique
- Nano-imprinting
- Micromanipulation
- Image processing / stabilization
- Nanopositioning with high flatness & straightness

- >> Capacitive Feedback Sensors
- >> Direct Metrology
- >> Flexure Guiding Systems
- >> PICMA® Multilayer Piezo Actuators
- >> Vacuum-Compatible Version

Technology Glossary page 240

	P-733.ZCD / P-733.ZCL	Unit	Tolerance
Active axes	Z		
Motion and positioning			
Integrated sensor	Capacitive		
Open-loop travel, -20 to 120 V	115	μm	+20 % / -0 %
Closed-loop travel	100	μm	
Open-loop resolution	0.2	nm	typ.
Closed-loop resolution	0.3	nm	typ.
Linearity error	0.03	%	typ.
Repeatability	<2	nm	typ.
Rotation around Z	<10	μrad	typ.
Rotation around X	<5	μrad	typ.
Rotation around Y	<5	μrad	typ.
Mechanical properties			
Stiffness	2.5	N/μm	±20 %
Resonant frequency, no load	700	Hz	±20 %
Resonant frequency, under load, at 120 g	530	Hz	±20 %
Resonant frequency, under load, at 200 g	415	Hz	±20 %
Push / pull force capacity	50 / 20	N	max.
Drive properties			
Piezo ceramic	PICMA® P-885		
Electrical capacitance	6	μF	±20 %
Miscellaneous			
Operating temperature range	20 to 80	°C	
Material	Aluminum		
Dimensions	100 mm × 100 mm × 25 mm		
Mass	580	g	±5 %
Cable length	1.5	m	±10 mm
Sensor / voltage connection	Sub-D 7W2 (m) (CD version); LEMO (CL version)		
Recommended electronics	E-503, E-505, E-610, E-621, E-625, E-754		

All specifications based on room temperature (22 °C ±3 °C).

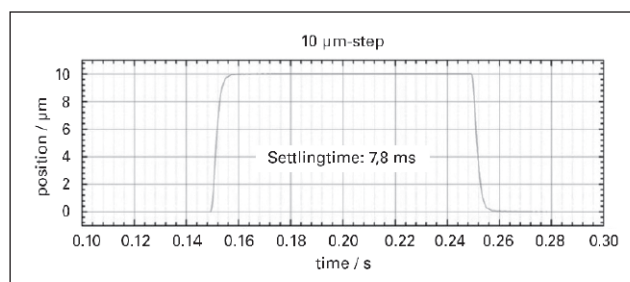
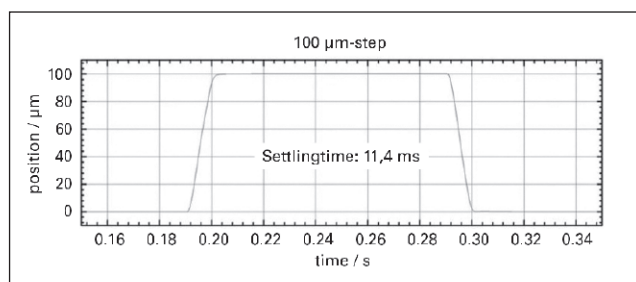

Step response of the P-733.ZCD. Settling time is in the 10 ms range.

S-303 Piezo Phase Shifter

High-Speed Piezo Phase Shifters with Direct Metrology Option

- Resonant frequency 25 kHz for sub-millisecond dynamics
- Capacitive sensor option for highest linearity and stability
- 3 μm travel range
- Compact size: Ø 30 mm × 10 mm
- Open-loop versions with aperture
- Invar option for highest thermal stability



S-303.0Lx, dimensions in mm.

S-303.CDx, dimensions in mm.

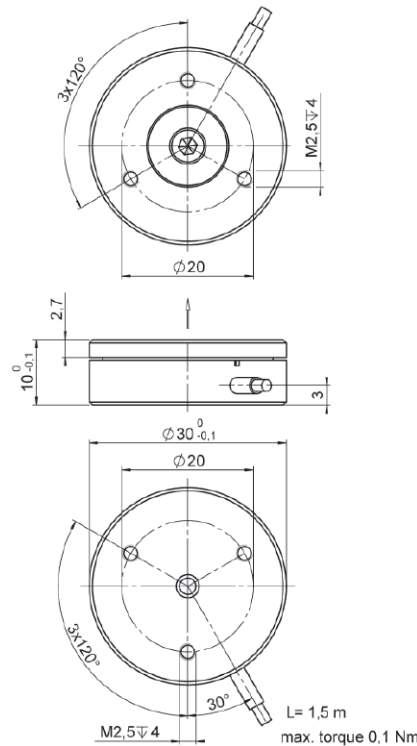
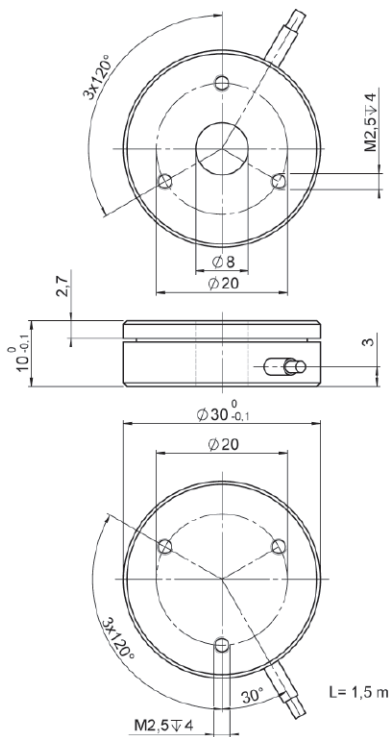

Applications

- (Fizeau) Interferometry
- Optical nanomanipulation and testing
- Scanning microscopy

- >> Capacitive Feedback Sensors
- >> Direct Metrology
- >> Flexure Guiding Systems
- >> PICMA® Multilayer Piezo Actuators

Technology Glossary page 240

	S-303.CDx	S-303.0Lx	Unit	Tolerance
Active axis	Z	Z		
Open-loop travel, at -20 to 120 V	3	3	μm	±20 %
Closed-loop travel	2	-	μm	
Integrated feedback sensor	Capacitive	-		
Resolution, closed-loop / open-loop*	0.03 / 0.03	0.03 / -	nm	
Linearity error, closed-loop**	1.0	-	%	typ.
Repeatability	0.7	-	nm	typ.
Stiffness	>400	>400	N/μm	
Push / pull force capacity	0.5	0.5	N	max.
Electrical capacitance	0.9	0.9	μF	±20 %
Resonant frequency, no load	25	25	kHz	±20 %
Operating temperature range	-20 to 80	-20 to 80	°C	
Voltage connection	Sub-D 7W2 (m)	LEMO		
Sensor connection	Sub-D 7W2 (m)	-		
Mass	100	30	g	±5 %
Casing material	Al (Invar optional)	Al (Invar optional)		
Recommended electronics	E-503, E-505, E-610, E-621, E-625, E-663, E-665, E-754	E-503, E-505, E-610, E-621, E-625, E-663, E-665, E-754		

* The resolution of PI piezo nanopositioners is not limited by friction or stiction. Value given is noise equivalent motion with E-503 amplifier or E-710 controller.

** With digital controller, analog controllers will provide a linearity of typ. 1 nm.

All specifications based on room temperature (22 °C ±3 °C).

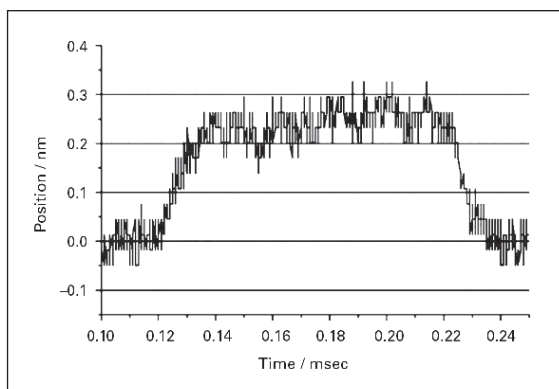

A 250 picometer step (0.25 nm) of the S-303 platform, controlled by an E-503 amplifier module and an E-509.C1A servocontroller module. Measured with special ultrahigh resolution capacitive gauge, ±0.02 nm resolution.

P-620.2 / P-629.2 PIHera XY Piezo Stage

High-precision XY Nanopositioning System with Variable Travel Ranges

P-62x.2CD / .2CL / .20L, dimensions in mm.

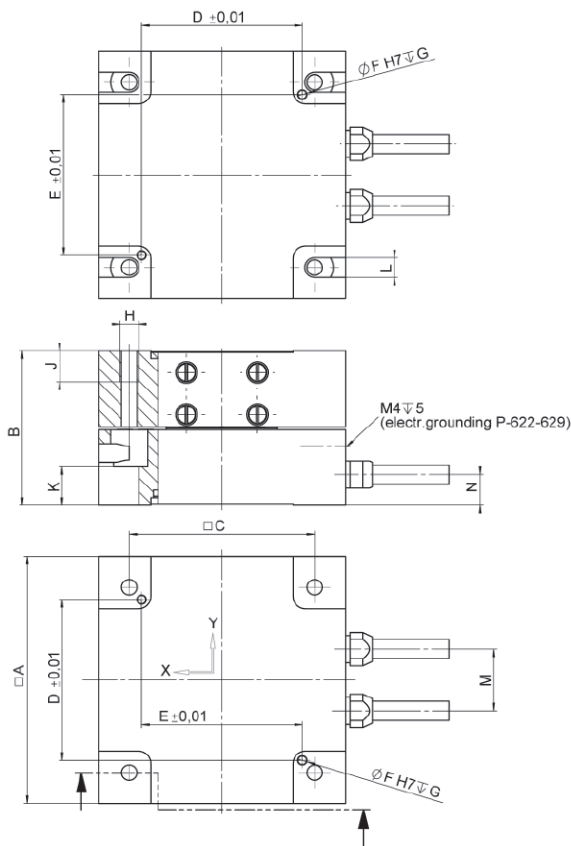

- Travel ranges 50 to 1800 µm
- Resolution to 0.1 nm
- Positioning accuracy 0.02 %
- Direct metrology with capacitive sensors
- X, XY, Z, XYZ versions

	A	B	C	D	E	ØF	G	H	J	K	L	M	N
P-620.2CD / 20L	30	21,5	24	24	19	1,01	1,5	M2	3,5	5,1	2,2	9	6
P-621.2CD / 20L	40	25	30	26	26	1,51	2,5	M3	5	6,25	3,2	10	5
P-622.2CD / 20L	50	25	40	35	35	1,51	2,5	M3	5	6,25	3,2	11	5
P-625.2CD / 20L	60	25	50	46	46	1,51	2,5	M3	6	6,25	3,2	11	5
P-628.2CD / 20L	80	30	70	66	66	1,51	2,5	M3	6	6,75	3,2	11	5
P-629.2CD / 20L	100	40	90	82	82	2,01	3,5	M4	7	6,75	4,3	16	7,5

Applications

- Interferometry
- Microscopy
- Nanopositioning
- Biotechnology
- Testing and quality processes
- Photonics
- Fiber positioning
- Semiconductor technology

- >> Capacitive Feedback Sensors
- >> Direct Metrology
- >> Flexure Guiding Systems
- >> PICMA® Multilayer Piezo Actuators
- >> Vacuum-Compatible Version

Technology Glossary page 240

	P-620.2CD / P-620.2CL	P-621.2CD / P-621.2CL	P-622.2CD / P-622.2CL	P-625.2CD / P-625.2CL	P-628.2CD / P-628.2CL	P-629.2CD / P-629.2CL	Unit	Tolerance
Active axes	X,Y	X,Y	X,Y	X,Y	X,Y	X,Y		
Motion and positioning								
Integrated sensor	Capacitive	Capacitive	Capacitive	Capacitive	Capacitive	Capacitive		
Travel range in X,Y at -20 to 120 V, open loop	60	120	300	600	950	1800	µm	+20 % / -0 %
Travel range in X,Y, closed loop	50	100	250	500	800	1500	µm	
Resolution in X,Y, open loop	0.1	0.2	0.4	0.5	0.5	2	nm	typ.
Resolution in X,Y, closed loop	0.2	0.4	0.7	1.4	3.5	3.5	nm	typ.
Linearity error in X,Y	0.02	0.02	0.02	0.03	0.03 ⁽¹⁾	0.03 ⁽²⁾	%	typ.
Repeatability X,Y	±2	±2	±2	±5	±10	±14	nm	typ.
Pitch / yaw	±3	±3	±3	±3 / ±5	±20 / ±5	±30 / ±5	µrad	typ.
Mechanical properties								
Stiffness X,Y	0.22	0.25	0.2	0.1	0.05	0.1	N/µm	±20 %
Resonant frequency in X, no load	575	420	225	135	75	60	Hz	±20 %
Resonant frequency in Y, no load	800	535	300	195	105	100	Hz	±20 %
Resonant frequency in X, under load, 50 g	270	285	180	120	60	55	Hz	±20 %
Resonant frequency in Y, under load, 50 g	395	365	215	150	85	85	Hz	±20 %
Resonant frequency in X, under load 100 g	285	220	160	105	55	50	Hz	±20 %
Resonant frequency in Y, under load, 100 g	300	285	175	125	75	80	Hz	±20 %
Compressive / tensile stress capacity in motion direction	10 / 5	10 / 8	10 / 8	10 / 8	10 / 8	10 / 8	N	max.
Load capacity	10	10	10	10	10	10	N	max.
Lateral force	10	10	10	10	10	10	N	max.
Drive properties								
Piezo ceramic	PICMA® P-883	PICMA® P-885	PICMA® P-885	PICMA® P-885	PICMA® P-887	PICMA® P-888		
Electrical capacitance in X,Y	0.35	1.5	3.1	6.2	19	52	µF	±20 %
Miscellaneous								
Operating temperature range	-20 to 80	-20 to 80	-20 to 80	-20 to 80	-20 to 80	-20 to 80	°C	
Material	Aluminum	Aluminum	Aluminum	Aluminum	Aluminum	Aluminum		
Dimensions	30 mm x 30 mm x 21.5 mm	40 mm x 40 mm x 25 mm	50 mm x 50 mm x 25 mm	60 mm x 60 mm x 25 mm	80 mm x 80 mm x 25 mm	100 mm x 100 mm x 40 mm		
Mass	0.195	0.295	0.348	0.43	0.7	1.37	kg	±5 %
Cable length	1.5	1.5	1.5	1.5	1.5	1.5	m	±10 mm
Sensor / voltage connection	CD versions: Sub-D 7W2 (m) CL versions: LEMO	CD versions: Sub-D 7W2 (m) CL versions: LEMO	CD versions: Sub-D 7W2 (m) CL versions: LEMO	CD versions: Sub-D 7W2 (m) CL versions: LEMO	CD versions: Sub-D 7W2 (m) CL versions: LEMO	CD versions: Sub-D 7W2 (m) CL versions: LEMO		
Recommended electronics	E-503, E-505, E-663, E-712, E-727	E-503, E-505, E-663, E-712, E-727	E-503, E-505, E-663, E-712, E-727	E-503, E-505, E-663, E-712, E-727	E-503, E-505, E-663, E-712, E-727	E-503, E-505, E-663, E-712, E-727		

(1) With digital controller. With analog controllers 0.05 %.

(2) With digital controller. With analog controllers 0.08 %.

Lower axis: X; upper axis: Y.

Versions without sensor are available under the P-62x.20L order numbers; operating temperature range -20 to 150 °C. Voltage connection LEMO.

Vacuum versions to 10⁻⁸ hPa are available under the P-62x.2UD order numbers.

The resolution of PI piezo nanopositioners is not limited by friction. Value given as noise with E-710 digital controller.

All specifications based on room temperature (22 °C ±3 °C).

P-611.XZ / P-611.2 XZ & XY Nanopositioner

Compact 2-Axis Piezo System for Nanopositioning Tasks

- Compact: Footprint 44 mm × 44 mm
- Travel range to 120 μm × 120 μm
- Resolution to 0.2 nm
- Cost-effective mechanics / electronics system configurations
- Zero-play, high-precision flexure guide system
- Outstanding lifetime due to PICMA® piezo actuators
- X, Z and XYZ version available



P-611.2S, dimensions in mm.

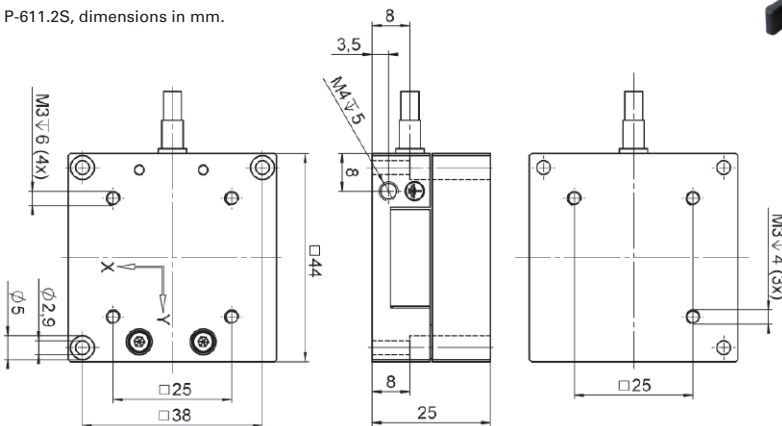

P-611.XZS, dimensions in mm.

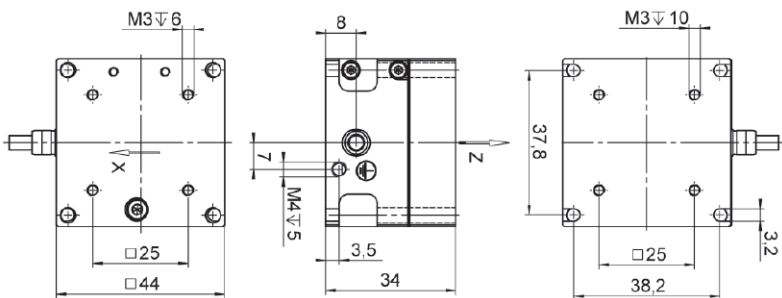

Applications

- Interferometry
- Microscopy
- Nanopositioning
- Biotechnology
- Testing and quality processes
- Photonics
- Fiber positioning
- Semiconductor technology

- >> Flexure Guiding Systems
- >> PICMA® Multilayer Piezo Actuators

Technology Glossary page 240

	P-611.2S	P-611.20	P-611.XZS	P-611.XZ0	Unit	Tolerance
Active axes	X, Y	X, Y	X, Z	X, Z		
Motion and positioning						
Integrated sensor	SGS	–	SGS	–		
Open-loop travel, –20 to 120 V	120	120	120	120	µm	+20 % / –0 %
Closed-loop travel	100	–	100	–	µm	
Open-loop resolution	0.2	0.2	0.2	0.2	nm	typ.
Closed-loop resolution	2	–	2	–	nm	typ.
Linearity error	0.1	–	0.1	–	%	typ.
Repeatability	<10	–	<10	–	nm	typ.
Pitch in X, Y	±5	±5	±5	±5	µrad	typ.
Runout θ_x (motion in Z)	–	–	±10	±10	µrad	typ.
Yaw in X	±20	±20	±20	±20	µrad	typ.
Yaw in Y	±10	±10	–	–	µrad	typ.
Runout θ_y (motion in Z)	–	–	±10	±10	µrad	typ.
Mechanical properties						
Stiffness	0.2	0.2	0.2 Z: 0.35	0.2 Z: 0.35	N/µm	±20 %
Resonant frequency, no load	X: 345; Y: 270	X: 345; Y: 270	X: 365; Z: 340	X: 365; Z: 340	Hz	±20 %
Resonant frequency, under load, at 30 g	X: 270; Y: 225	X: 270; Y: 225	X: 280; Z: 295	X: 280; Z: 295	Hz	±20 %
Resonant frequency, under load, at 100 g	X: 180; Y: 165	X: 180; Y: 165	X: 185; Z: 230	X: 185; Z: 230	Hz	±20 %
Push / pull force capacity in motion direction	15 / 10	15 / 10	15 / 10	15 / 10	N	max.
Load capacity	15	15	15	15	N	max.
Drive properties						
Ceramic type	PICMA® P-885	PICMA® P-885	PICMA® P-885	PICMA® P-885		
Electrical capacitance	1.5	1.5	1.5	1.5	µF	±20 %
Miscellaneous						
Operating temperature range	–20 to 80	–20 to 80	–20 to 80	–20 to 80	°C	
Material	Aluminum, steel	Aluminum, steel	Aluminum, steel	Aluminum, steel		
Dimensions	44 mm × 44 mm × 25 mm	44 mm × 44 mm × 25 mm	44 mm × 44 mm × 34 mm	44 mm × 44 mm × 34 mm		
Mass	0.235	0.235	0.27	0.27	kg	±5 %
Cable length	1.5	1.5	1.5	1.5	m	±10 mm
Sensor connection	LEMO	–	LEMO	–		
Voltage connection	LEMO	LEMO	LEMO	LEMO		
Recommended electronics	E-503, E-505, E-663, E-664, E-727	E-503, E-505, E-663, E-664, E-727	E-503, E-505, E-663, E-664, E-727	E-503, E-505, E-663, E-664, E-727		

The resolution of PI piezo nanopositioners is not limited by friction or stiction. Value is given noise equivalent motion with E-503 amplifier. All specifications based on room temperature (22 °C ±3 °C).

P-541.2 / P-542.2 XY Piezo Stage

Low-Profile XY Nanopositioning System with Large Aperture



- Low profile for easy integration: 16.5 mm
- Clear aperture 80 mm × 80 mm
- Travel range to 200 μm × 200 μm
- Parallel kinematics for faster response times and higher multi-axis accuracy
- High-dynamics direct-drive version
- Choice of sensors: Strain gauge (lower cost) or capacitive sensors (higher performance)
- Outstanding lifetime due to PICMA® piezo actuators
- Combination with long-travel microscopy stages for longer stroke

P-541.2 / P-542.2, dimensions in mm.

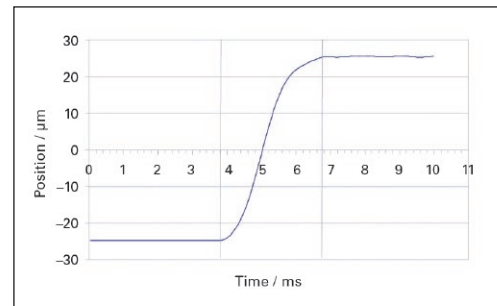
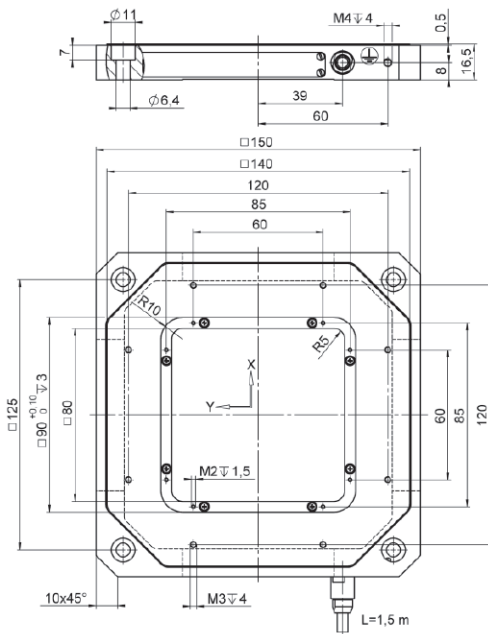

The settling time of a P-541.2DD stage is only 3 ms for a 50 μm step.

Applications

- Scanning microscopy
- Hightthroughput microscopy
- Super-resolution microscopy
- Mask / wafer positioning
- Interferometry
- Metrology
- Biotechnology
- Micromanipulation

- >> Capacitive Feedback Sensors
- >> Direct Metrology
- >> Flexure Guiding Systems
- >> Parallel-Kinematic Piezo Stages
- >> PICMA® Multilayer Piezo Actuators

Technology Glossary page 240

	P-541.2CD / P-541.2CL	P-542.2CD / P-542.2CL	P-541.2DD	P-541.2SL	P-542.2SL	P-541.20L / P-542.20L	Unit	Tolerance
Active axes	X, Y	X, Y	X, Y	X, Y	X, Y	X, Y		
Motion and positioning								
Integrated sensor	Capacitive	Capacitive	Capacitive	SGS	SGS	–		
Open-loop travel, –20 to +120 V	150 µm × 150 µm	250 µm × 250 µm	60 µm × 60 µm	150 µm × 150 µm	250 µm × 250 µm	see P-541.2CD / P-542.2CD		+20 % / –0 %
Closed-loop travel	100 µm × 100 µm	200 µm × 200 µm	45 µm × 45 µm	100 µm × 100 µm	200 µm × 200 µm	–		
Closed-loop / open-loop resolution	0.2 / 0.3	0.4 / 0.7	0.1 / 0.3	0.2 / 2.5	0.4 / 4	open-loop 0.2 / 0.4	nm	typ.
Linearity error	0.03	0.03	0.03*	0.2	0.2	–	%	typ.
Repeatability	<5	<5	<5	<10	<10	–	nm	typ.
Pitch	<5	<5	<3	<5	<5	<5	µrad	typ.
Yaw	<10	<10	<3	<10	<10	<10	µrad	typ.
Mechanical properties								
Stiffness in motion direction	0.47	0.4	10	0.47	0.4	0.47 / 0.4	N/µm	±20 %
Resonant frequency, no load	255	230	1550	255	230	255 / 230	Hz	±20 %
Resonant frequency, under load, at 100 g	200	190	–	200	190	200 / 190	Hz	±20 %
Resonant frequency, under load, at 200 g	180	–	1230	180	–	180 / –	Hz	±20 %
Resonant frequency, under load, at 300 g	150	145	–	150	145	150 / 145	Hz	±20 %
Push / pull force capacity in motion direction	100 / 30	100 / 30	100 / 30	100 / 30	100 / 30	100 / 30	N	max.
Load capacity	20	20	20	20	20	20	N	max.
Drive properties								
Piezoelectric ceramic	PICMA® P-885	PICMA® P-885	PICMA® P-885	PICMA® P-885	PICMA® P-885	PICMA® P-885		
Electrical capacitance per axis	4.2	7.5	9	4.2	7.5	4.2 / 7.5	µF	±20 %
Miscellaneous								
Operating temperature range	–20 to 80	–20 to 80	–20 to 80	–20 to 80	–20 to 80	–20 to 80	°C	
Material	Aluminum	Aluminum	Aluminum	Aluminum	Aluminum	Aluminum		
Mass	0.75	0.75	0.75	0.73	0.73	0.7	kg	±5 %
Cable length	1.5	1.5	1.5	1.5	1.5	1.5	m	±10 mm
Sensor / voltage connection	CD versions: Sub-D 25W3 (m) CL versions: LEMO	CD versions: Sub-D 25W3 (m) CL versions: LEMO	Sub-D 25W3 (m)	LEMO	LEMO	LEMO (no sensor)		
Recommended electronics	E-503, E-505, E-621, E-712, E-727	E-503, E-505, E-621, E-712, E-727	E-503, E-505, E-621, E-712, E-727	E-503, E-505, E-621, E-712, E-727	E-503, E-505, E-621, E-712, E-727	E-503, E-505, E-621, E-712, E-727		

* With digital controller. Non-linearity of direct drive stages measured with analog controllers is up to 0.1 % typ.
All specifications based on room temperature (22 °C ±3 °C).

P-612.2 XY Piezo Nanopositioning System

Compact, Clear Aperture



- Compact: Footprint 60 mm × 60 mm
- 100 μm × 100 μm closed-loop travel range (130 μm × 130 μm, open-loop)
- For cost-sensitive applications
- Clear aperture 20 mm × 20 mm
- Parallel kinematics for faster response times and higher multi-axis accuracy
- Outstanding lifetime due to PICMA® piezo actuators
- Available as compact version

P-612.2, dimensions in mm.

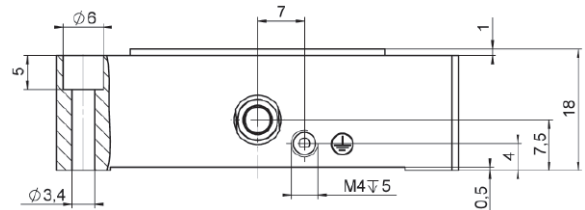
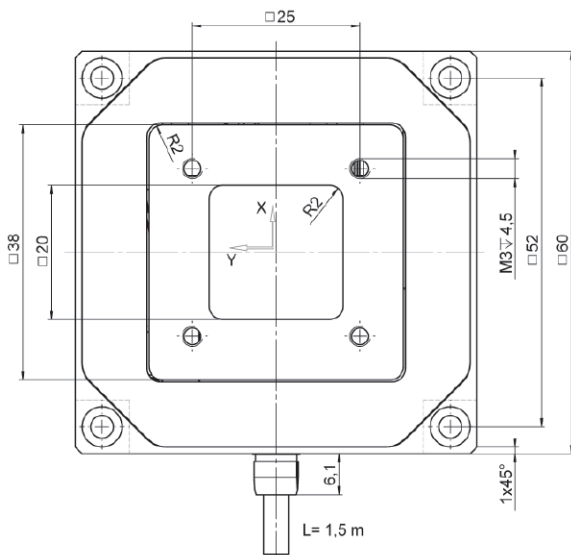

Applications

- Scanning microscopy
- High-throughput microscopy
- Super-resolution microscopy
- Mask / wafer positioning
- Interferometry
- Metrology
- Biotechnology
- Micromanipulation

- >> Flexure Guiding Systems
- >> PICMA® Multilayer Piezo Actuators

Technology Glossary page 240

	P-612.2SL	P-612.20L	Unit	Tolerance
Active axes	X,Y	X,Y		
Motion and positioning				
Integrated sensor	SGS	–		
Open-loop travel, –20 to +120 V	130	130	µm	+20 % / –0 %
Closed-loop travel range	100	–	µm	
Open-loop resolution	0.8	0.8	nm	typ.
Closed-loop resolution	5	–	nm	typ.
Linearity error	0.4	–	%	typ.
Repeatability	<10	–	nm	typ.
Pitch	±10	±10	µrad	typ.
Yaw in X / Y	±10 / ±50	±10 / ±50	µrad	typ.
Mechanical properties				
Stiffness	0.15	0.15	N/µm	±20 %
Resonant frequency, no load	400	400	Hz	±20 %
Resonant frequency at 100 g	200	200	Hz	±20 %
Compressive / tensile stress capacity in motion direction	15 / 5	15 / 5	N	max.
Load capacity	15	15	N	max.
Drive properties				
Ceramic type	PICMA® P-885	PICMA® P-885		
Electrical capacitance	1.5	1.5	µF	±20 %
Miscellaneous				
Operating temperature range	–20 to 80	–20 to 80	°C	
Material	Aluminum, steel	Aluminum, steel		
Mass	105	105	g	±5 %
Cable length	1.5	1.5	m	±10 mm
Sensor / voltage connection	LEMO	LEMO (no sensor)		
Recommended electronics	E-503, E-505, E-621	E-503, E-505, E-621		

Resolution of PI piezo nanopositioning systems is not limited by friction or stiction. Value given is noise equivalent motion with E-503 amplifier. All specifications based on room temperature (22 °C ±3 °C).

P-733.2 XY Piezo Nanopositioner

High-Precision XY Scanner with Aperture

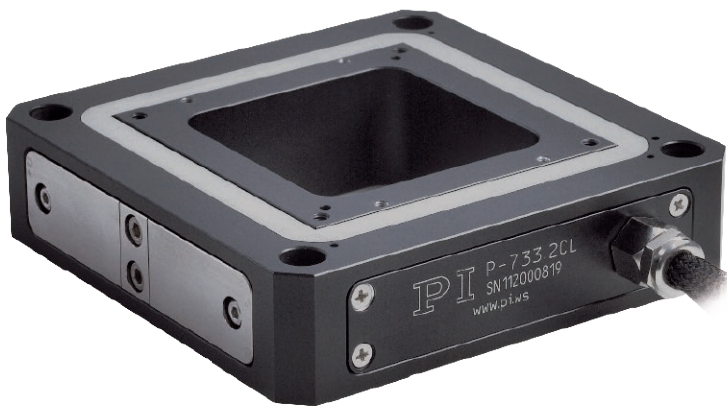

- Travel ranges to 100 μm \times 100 μm in X and Y
- Resolution to 0.1 nm due to capacitive sensors
- High-speed versions with direct drive
- Vacuum-compatible and non-magnetic versions available
- Parallel kinematics for higher accuracy and dynamics
- Parallel metrology for active compensation of guiding errors
- Zero-play, high-precision flexure guide system
- Clear aperture 50 mm \times 50 mm for transmitted-light applications

P-733.2DD, dimensions in mm.

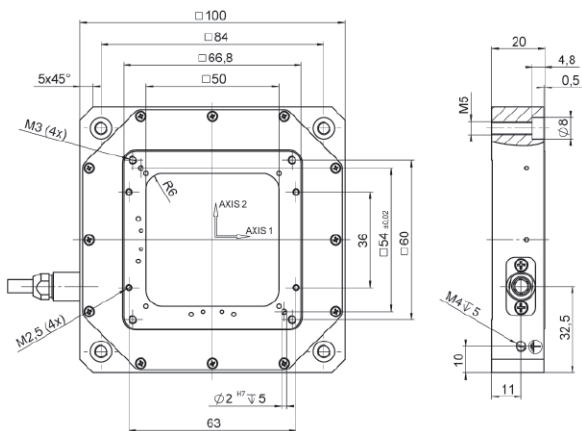

P-733.2CD/.2CL, dimensions in mm.

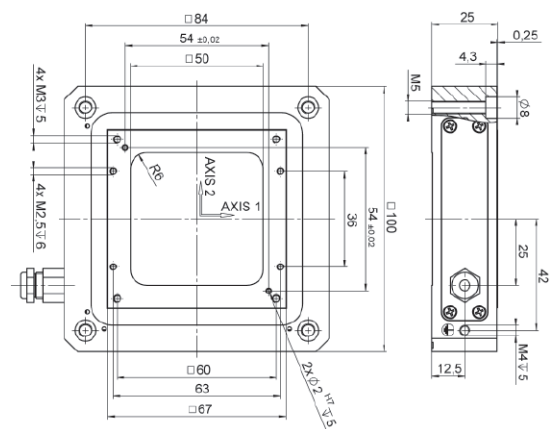

Applications

- Scanning microscopy
- Confocal microscopy
- Mask / wafer positioning
- Surface measurement technique
- Nano-imprinting
- Micromanipulation
- Image processing / stabilization
- Nanopositioning with high flatness & straightness

- >> Capacitive Feedback Sensors
- >> Direct Metrology
- >> Flexure Guiding Systems
- >> Parallel-Kinematic Piezo Stages
- >> PICMA® Multilayer Piezo Actuators
- >> Vacuum-Compatible Version

Technology Glossary page 240

	P-733.2CD / P-733.2CL	P-733.2DD	Unit	Tolerance
Active axes	X, Y	X, Y		
Motion and positioning				
Integrated sensor	Capacitive	Capacitive		
Open-loop travel range, -20 to 120 V	115 µm × 115 µm	33 µm × 33 µm		+20 % / -0 %
Closed-loop travel range	100 µm × 100 µm	30 µm × 30 µm		
Open-loop resolution	0.2	0.1	nm	typ.
Closed-loop resolution	0.3	0.1	nm	typ.
Linearity error (X, Y)	0.03	0.03*	%	typ.
Repeatability (X, Y)	<2	<2	nm	typ.
Pitch (X, Y)	<±3	<±5	µrad	typ.
Yaw (X, Y)	<±10	<±10	µrad	typ.
Mechanical properties				
Stiffness	1.5	20	N/µm	±20 %
Resonant frequency, no load	500	2230	Hz	±20 %
Resonant frequency, under load, 120 g	370	–	Hz	±20 %
Resonant frequency, under load, 200 g	340	1550	Hz	±20 %
Compressive / tensile stress capacity in motion direction	50 / 20	50 / 20	N	max.
Drive properties				
Piezo ceramic	PICMA® P-885	PICMA® P-885		
Electrical capacitance	6	6.2	µF	±20 %
Miscellaneous				
Operating temperature range	-20 to 80	-20 to 80	°C	
Material	Aluminum	Aluminum		
Mass	0.58	0.58	kg	±5 %
Cable length	1.5	1.5	m	±10 mm
Sensor / voltage connection	Sub-D 25W3 (m) (CD version); LEMO (CL version)	Sub-D 25W3 (m)		
Recommended electronics	E-503, E-505, E-610, E-621, E-625, E-712	E-503, E-505, E-610, E-621, E-625, E-712		

* With digital controller. Nonlinearity of direct drive stages measured with analog controllers is up to 0.1 % typ.
All specifications based on room temperature (22 °C ±3 °C).
Ask about custom designs!

P-616 NanoCube® Nanopositioner

Compact Parallel-Kinematic Piezo System for Nanopositioning and Fiber Alignment

- Parallel-kinematic design for the highest stiffness in all spatial directions
- Highly dynamic motion due to high resonant frequencies even with loads up to 100 g
- Innovative product design for flexible use due to single mounting platform
- Only nanopositioner available on the market with ID chip functionality
- Smallest and lightest NanoCube® with 100 µm travel range on the market

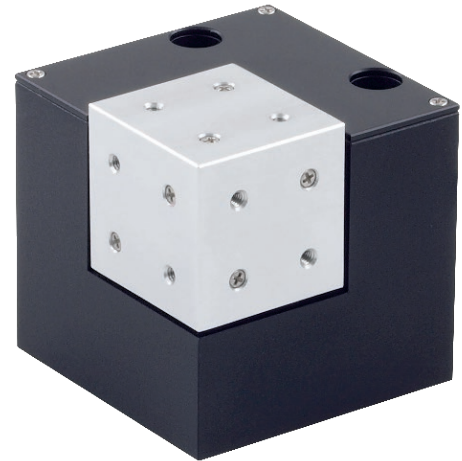

P-616.3C, Dimensions in mm.
Note that the decimal places are separated by a comma in the drawings.

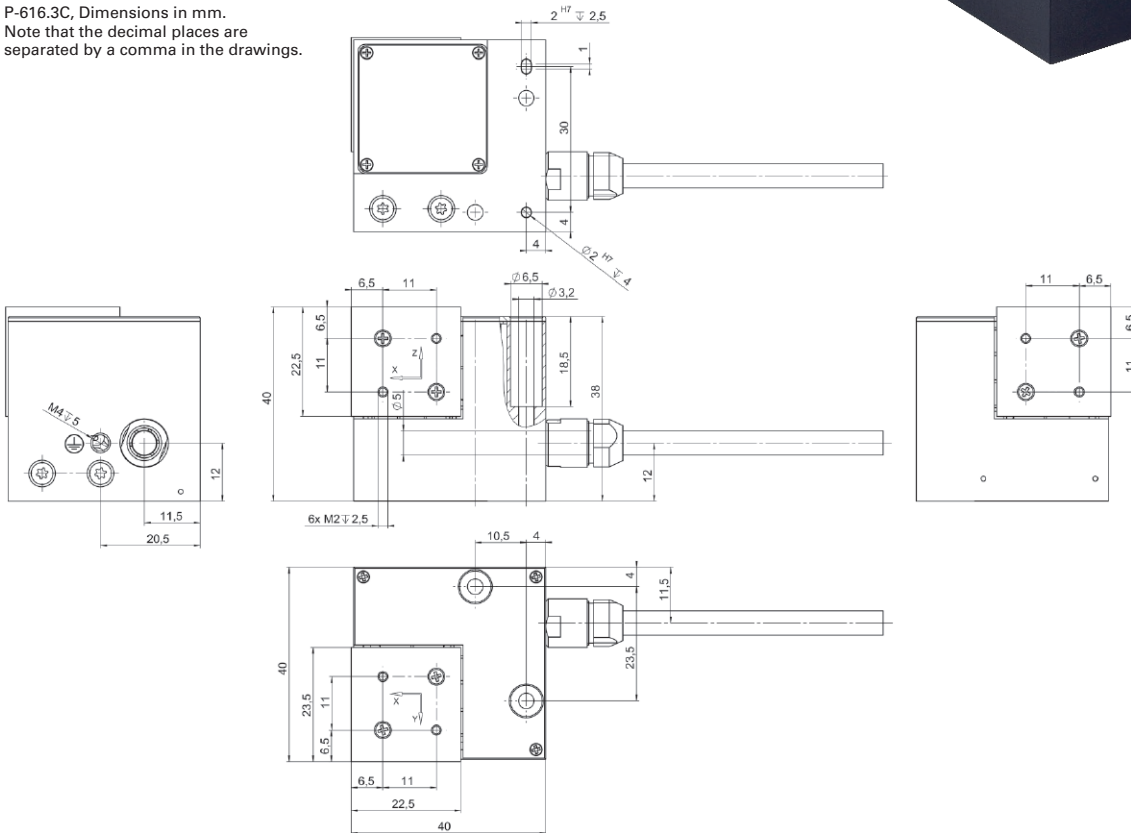

Applications

- Fiber positioning and alignment
- Photonics / integrated optics
- Scanning microscopy
- Micromanipulation
- Sample positioning
- Scanning and screening

- >> Capacitive Feedback Sensors
- >> Flexure Guiding Systems
- >> Parallel-Kinematic Piezo Stages
- >> PICMA® Multilayer Piezo Actuators
- >> Vacuum-Compatible Version

Technology Glossary page 240

	P-616.3C	Unit	Tolerance
Motion and positioning			
Active axes	X, Y, Z		
Travel range at -20 to 120 V, open loop	110 / axis	μm	+20 % / -0 %
Closed-loop travel range	100 / axis	μm	+20 % / -0 %
Resolution, 1 σ, open loop*	0.3	nm	typ.
Resolution, 1 σ, closed loop*	0.4	nm	typ.
Linearity error, for the entire travel range, with digital controller (E-727.3CD)	0.03	%	typ.
Bidirectional repeatability, 1 σ, 10 % travel range	<10	nm	typ.
Bidirectional repeatability, 1 σ, 100 % travel range	<15	nm	typ.
Sensor			
Sensor type	Capacitive sensors		
Mechanical properties			
Stiffness	0.5	N/μm	±10 %
Resonant frequency X / Y / Z, no load	700	Hz	±10 %
Resonant frequency with 38 g load X / Y / Z	380	Hz	±20 %
Resonant frequency with 100 g load X / Y / Z	250	Hz	±20 %
Compressive/tensile stress capacity	15	N	max.
Maximum permissible torque	0.4	Nm	max.
Recommended maximum load	300	g	max.
Drive properties			
Ceramic type	PICMA® P-885.50		
Electrical capacitance	1.5 / axis	μF	±20 %
Miscellaneous			
Operating temperature range	-20 to 80	°C	
Material	Aluminum, steel		
Dimensions	40 × 40 × 40	mm	
Moved mass without load	0.021	kg	
Mass without cable	0.125	kg	
Mass with cable	0.4	kg	
Cable length	1.5	m	±10 mm
Connection	Sub-D 25W3 (m)		
Recommended electronics	E-503, E-663, E-712, E-727		

* The resolution of PI piezo nanopositioning systems is not limited by friction. Specification as position noise with E-727 controller. All specifications based on room temperature (22 °C ±3 °C).

P-611.3 NanoCube® XYZ Piezo Stage

Compact Multi-Axis Piezo System for Nanopositioning and Fiber Alignment



- Travel range to 120 µm × 120 µm × 120 µm
- Ultra-compact: 44 mm × 44 mm × 44 mm
- Resolution to 0.2 nm
- Rapid response
- Zero-play, high-precision flexure guide system
- Outstanding lifetime due to PICMA® piezo actuators
- For fast scanning
- Version with integrated fiber adapter interface
- Especially cost-effective systems

P-611.3, dimensions in mm

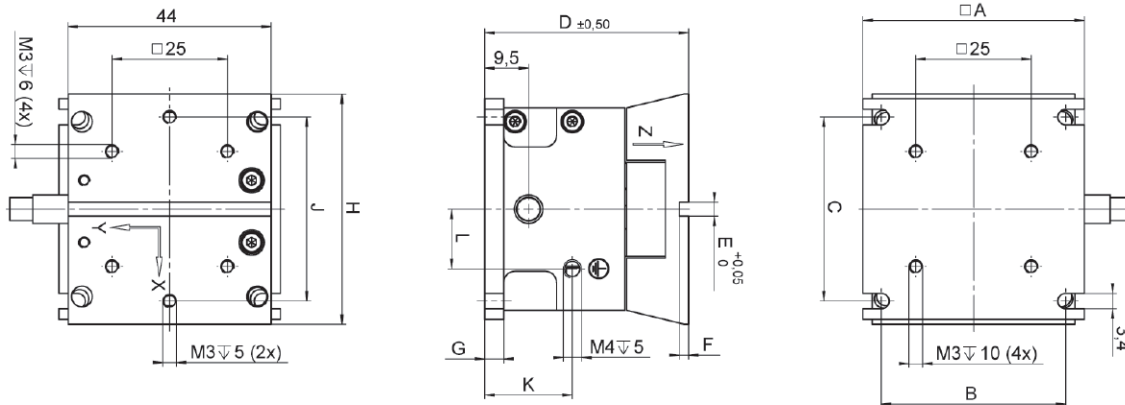

	A	B	C	D	E	F	G	H	J	K	L
P-611.3O	44	38.2	37.8	43.2	-	-	3.5	44	-	3.5	10
P-611.3S	44	38.2	37.8	43.2	-	-	3.5	44	-	3.5	10
P-611.3OF	44	38.2	37.8	44.2	3	2	3.5	50	40	3.5	10
P-611.3SF	48	40	40	44.2	3	2	4.1	50	40	19	13

Applications

- Photonics / integrated optics
- Micromanipulation
- Biotechnology
- Semiconductor testing
- Fiber positioning

- >> Flexure Guiding Systems
- >> PICMA® Multilayer Piezo Actuators

Technology Glossary page 240

	P-611.3S P-611.3SF	P-611.3O P-611.3OF	Unit	Tolerance
Active axes	X, Y, Z	X, Y, Z		
Motion and positioning				
Integrated sensor	SGS			
Open-loop travel, -20 to 120 V	120 / axis	120 / axis	µm	+20 % / -0 %
Closed-loop travel	100 / axis	-	µm	
Open-loop resolution	0.2	0.2	nm	typ.
Closed-loop resolution	1	-	nm	typ.
Linearity error	0.1	-	%	typ.
Repeatability	<10	-	nm	typ.
Pitch in X, Y	±5	±5	µrad	typ.
Runout θ _x (motion in Z)	±10	±10	µrad	typ.
Yaw in X	±20	±20	µrad	typ.
Yaw in Y	±10	±10	µrad	typ.
Runout θ _y (motion in Z)	±10	±10	µrad	typ.
Mechanical properties				
Stiffness	0.3	0.3	N/µm	±20 %
Unloaded resonant frequency X / Y / Z	350 / 220 / 250	350 / 220 / 250	Hz	±20 %
Resonant frequency at 30 g in X / Y / Z	270 / 185 / 230	270 / 185 / 230	Hz	±20 %
Resonant frequency at 100 g in X / Y / Z	180 / 135 / 200	180 / 135 / 200	Hz	±20 %
Push / pull force capacity in motion direction	15 / 10	15 / 10	N	max.
Load capacity	15	15	N	max.
Drive properties				
Ceramic type	PICMA® P-885	PICMA® P-885		
Electrical capacitance	1.5	1.5	µF	±20 %
Miscellaneous				
Operating temperature range	-20 to 80	-20 to 80	°C	
Material	Aluminum, steel	Aluminum, steel		
Dimensions	S version: 48 mm × 44 mm × 43.2 mm SF version: 44 mm × 50 mm × 44.2 mm	O version: 44 mm × 44 mm × 43.2 mm OF version: 44 mm × 50 mm × 44.2 mm		
Mass	0.32	0.32	kg	±5 %
Cable length	1.5	1.5	m	±10 mm
Sensor connection	Sub-D 25 (m)	-		
Voltage connection	Sub-D 25 (m)	Sub-D 25 (m)		
Recommended electronics	E-503, E-505, E-663, E 664, E-727	E-503, E-505, E-663, E 664, E-727		

The resolution of PI piezo nanopositioners is not limited by friction or stiction. Value is given noise equivalent motion with E-503 amplifier.

Adapter cable with LEMO connectors for sensor and operating voltage available.

All specifications based on room temperature (22 °C ±3 °C).

Ask about custom designs!

P-313 PicoCube XY(Z) Piezo Scanner

Picometer Precision, High Bandwidth, for Scanning Probe Microscopy



- Highly linear scanner for AFM / SPM
- Up to 20 picometers resolution, hysteresis <1 nm
- Highest bandwidth due to open-loop drive concept
- Highest-resolution manipulation tool for biotechnology / nanotechnology
- Resonant frequency 4.0 kHz (X, Y), 11 kHz (Z)
- Travel range 1 $\mu\text{m} \times 1 \mu\text{m} \times 0.6 \mu\text{m}$

P-313, dimensions in mm.

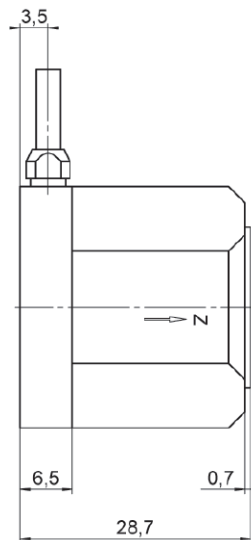
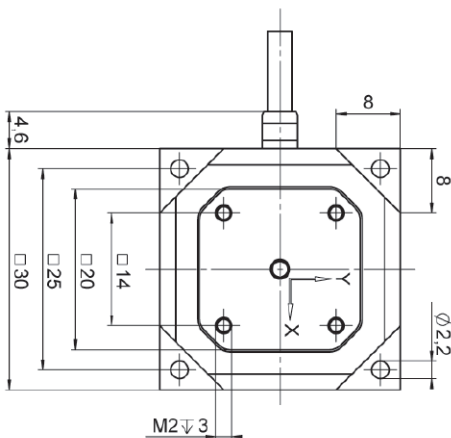

Applications

- Scanning probe microscopy
- Atomic force microscopy
- Scanning and screening

- >> Flexure Guiding Systems
- >> Parallel-Kinematic Piezo Stages

Technology Glossary page 240

	P-313 PicoCube XY(Z) piezo scanner	Unit
Motion and positioning		
Active axes	X, Y, Z	
Travel range X,Y (± 250 V)	1	μm
Travel range Z (± 250 V)	0.6	μm
Resolution in X,Y	0.02	nm
Resolution in Z	0.14	nm
Mechanical properties		
Resonant frequency in X, Y	4	kHz
Resonant frequency in Z	11	kHz
Compressive / tensile stress capacity in motion direction	± 10	N
Load capacity	± 10	N
Miscellaneous		
Operating temperature range	5 to 40	$^{\circ}\text{C}$
Mass	80	g
Cable length	1.5	m
Voltage connection	Sub-D 24W7 (m)	
Recommended electronics	E-536	

All specifications based on room temperature ($22^{\circ}\text{C} \pm 3^{\circ}\text{C}$).

P-363 PicoCube XY(Z) Piezo Scanner

High-Dynamics Nanoscanner for Scanning Probe Microscopy



- Ultra-high-performance closed-loop scanner for AFM / SPM
- Compact manipulation tool for bio- / nanotechnology
- Resonant frequency 9.8 kHz
- Capacitive sensors for highest accuracy
- Parallel-motion metrology for automated compensation of guiding errors
- Resolution 50 picometer
- Travel range $5 \mu\text{m} \times 5 \mu\text{m} \times 5 \mu\text{m}$
- Vacuum-compatible versions

P-363.3Cx, dimensions in mm. Removable top plate.

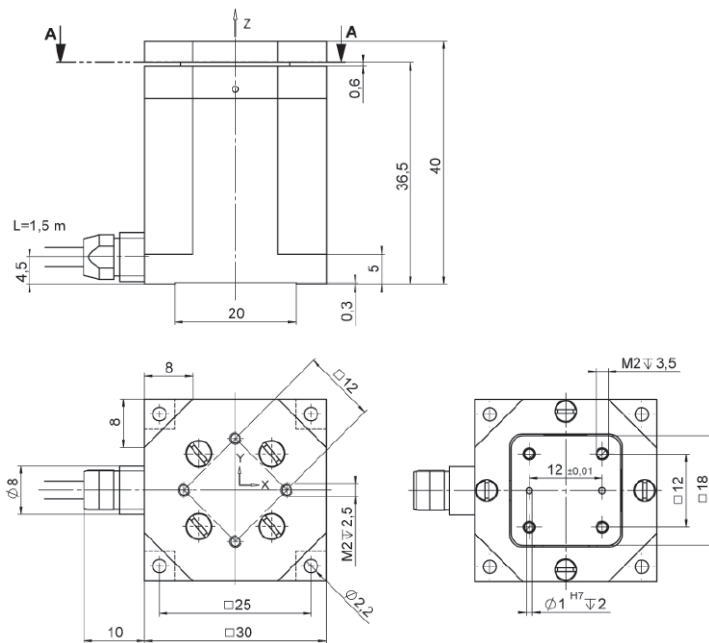

P-363.2Cx, dimensions in mm. Removable top plate.

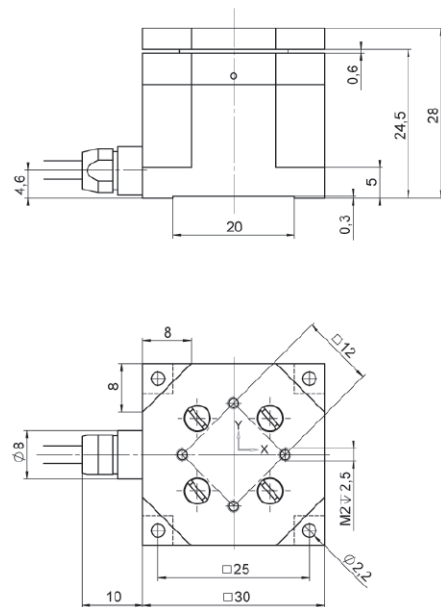

Applications

- Scanning probe microscopy
- Atomic force microscopy
- Scanning and screening

- >> Capacitive Feedback Sensors
- >> Flexure Guiding Systems
- >> Parallel Metrology
- >> Vacuum-Compatible Version

Technology Glossary page 240

	P-363.3CD	P-363.2CD	Unit
Active axes	X,Y,Z	X,Y	
Motion and positioning			
Integrated sensor	Capacitive	Capacitive	
Open-loop travel in X,Y, -250 to +250 V	±3	±3	µm
Open-loop travel in Z, -250 to +250 V	±2.7	–	µm
Closed-loop travel in X,Y	±2.5	±2.5	µm
Closed-loop travel in Z	±2.5	–	µm
Open-loop resolution*	0.03	0.03	nm
Closed-loop resolution	0.1	0.1	nm
Linearity error	0.05	0.05	%
Repeatability**	1	1	nm
Pitch / yaw in X,Y	0.5	0.5	µrad
Runout X,Y (Z motion)	0.2	–	µrad
Straightness in X,Y	3	3	nm
Flatness in X,Y	<10	<10	nm
Crosstalk in X,Y (motion in Z)	5	–	nm
Mechanical properties			
Unloaded resonant frequency in X,Y	3.1	4.2	kHz
Unloaded resonant frequency in Z	9.8	–	kHz
Loaded resonant frequency in X,Y	1.5 (20 g)	2.1 (20 g)	kHz
Load capacity	10	10	N
Ceramic type	PICA, PICA Shear	PICA Shear	
Miscellaneous			
Operating temperature range	–20 to 80	–20 to 80	°C
Material	Titanium	Titanium	
Dimensions	30 mm × 30 mm × 40 mm	30 mm × 30 mm × 28 mm	
Mass	225	190	g
Cable length	1.5	1.5	m
Sensor / voltage connection	Sub-D 24W7 (m)	Sub-D 24W7 (m)	
Recommended electronics	E-536	E-536	

* With E-536.3xH controller.

The resolution of PI piezo nanopositioners is not limited by friction or stiction. Value given is noise equivalent motion with E-536.

** For 10 % travel in Z; 50 nm for 100 % travel in Z.

All specifications based on room temperature (22 °C ±3 °C). Ask about custom designs!

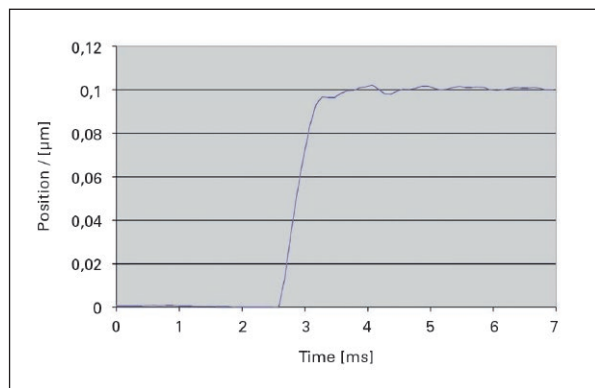

The P-363 settles to within 1 nm in 1 ms (100 nm step, X and Y motion; faster response in Z).

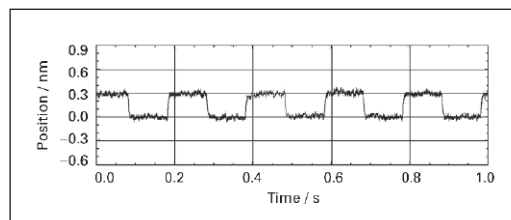

300 picometer steps (0.3 nm) performed with the P-363, measured with an external high-resolution, capacitive measurement system.

P-733.3 XYZ Piezo Nanopositioner

High-Precision XYZ Scanner with Aperture

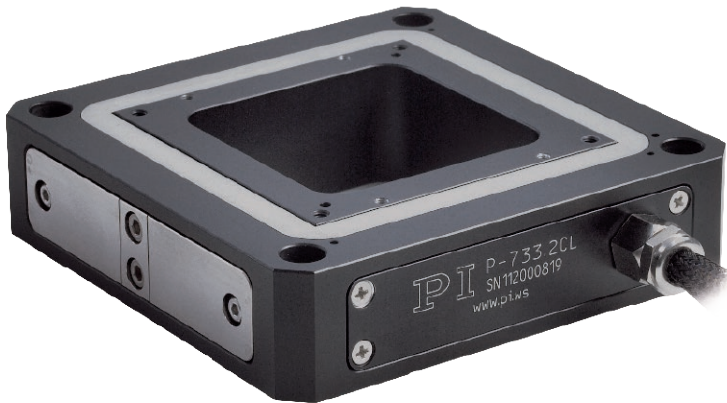

- Travel ranges to 100 μm \times 100 μm in X,Y and to 10 μm in Z
- Resolution to 0.1 nm due to capacitive sensors
- High-speed versions with direct drive
- Ultra-high-vacuum compatible and non-magnetic versions
- Parallel kinematics for higher accuracy and dynamics
- Parallel metrology for active compensation of guiding errors
- Zero-play, high-precision flexure guide system
- Clear aperture 50 mm \times 50 mm for transmitted-light applications

P-733.3CD/.3CL, dimensions in mm.

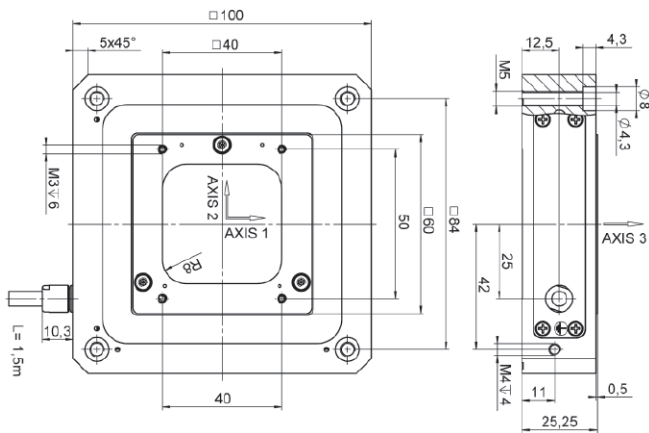

P-733.3DD, dimensions in mm.

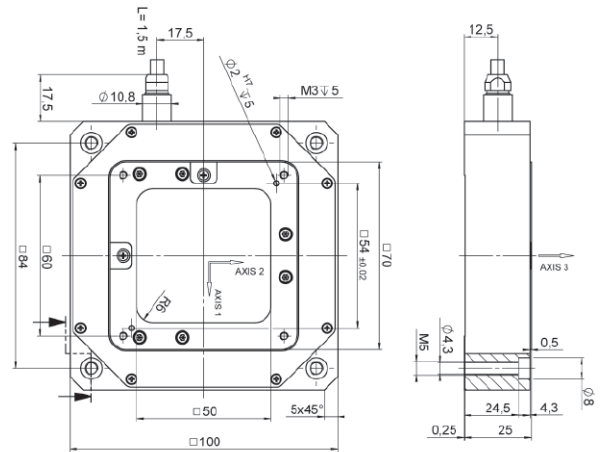

Applications

- Scanning microscopy
- Confocal microscopy
- Mask / wafer positioning
- Surface measurement technique
- Nano-imprinting
- Micromanipulation
- Image processing / stabilization
- Nanopositioning with high flatness & straightness

- >> Capacitive Feedback Sensors
- >> Flexure Guiding Systems
- >> Parallel Metrology
- >> PICMA® Multilayer Piezo Actuators
- >> Vacuum-Compatible Version

Technology Glossary page 240

	P-733.3CD P-733.3CL	P-733.3DD	Unit	Tolerance
Active axes	X, Y, Z	X, Y, Z		
Motion and positioning				
Integrated sensor	Capacitive	Capacitive		
Open-loop travel range, -20 to 120 V	115 µm × 115 µm × 12 µm	33 µm × 33 µm × 14 µm		+20 % / -0 %
Closed-loop travel range	100 µm × 100 µm × 10 µm	30 µm × 30 µm × 10 µm		
Open-loop resolution	0.2 (0.1 in Z)	0.1	nm	typ.
Closed-loop resolution	0.3 (0.2 in Z)	0.1	nm	typ.
Linearity error (X, Y)	0.03	0.03*	%	typ.
Linearity error (Z)	0.03	0.03*	%	typ.
Repeatability (X, Y)	<2	<2	nm	typ.
Repeatability (Z)	<1	<1	nm	typ.
Pitch (X, Y)	<±3	<±5	µrad	typ.
Yaw (X, Y)	<±10	<±10	µrad	typ.
Runout θ _z (motion in Z)	<±5	<±5	µrad	typ.
Mechanical properties				
Stiffness	1.4 (9 in Z)	4 (10 in Z)	N/µm	±20 %
Resonant frequency, no load	460 (1400 in Z)	1200 (1100 in Z)	Hz	±20 %
Resonant frequency, under load, 120 g	340 (1060 in Z)	-	Hz	±20 %
Resonant frequency, under load, 200 g	295 (650 in Z)	530 (635 in Z)	Hz	±20 %
Compressive/tensile stress capacity in motion direction	50 / 20	50 / 20	N	max.
Drive properties				
Piezo ceramic	PICMA® P-885	PICMA® P-885		
Electrical capacitance	6 (2.4 in Z)	6.2 (3.3 in Z)	µF	±20 %
Miscellaneous				
Operating temperature range	-20 to 80	-20 to 80	°C	
Material	Aluminum	Aluminum		
Mass	0.675	0.675	kg	±5 %
Cable length	1.5	1.5	m	±10 mm
Sensor / voltage connection	Sub-D 25W3 (m) (CD version);			
LEMO (CL version)	Sub-D 25W3 (m)			
Recommended electronics	E-503, E-505, E-610, E-621, E-625, E-712	E-503, E-505, E-610, E-621, E-625, E-712		

* With digital controller. Nonlinearity of direct drive stages measured with analog controllers is up to 0.1 % typ.

All specifications based on room temperature (22 °C ±3 °C).

Ask about custom designs!

P-561 / P-562 / P-563 PIMars Nanopositioning Stage

High-Precision Nanopositioning System for up to 3 Axes

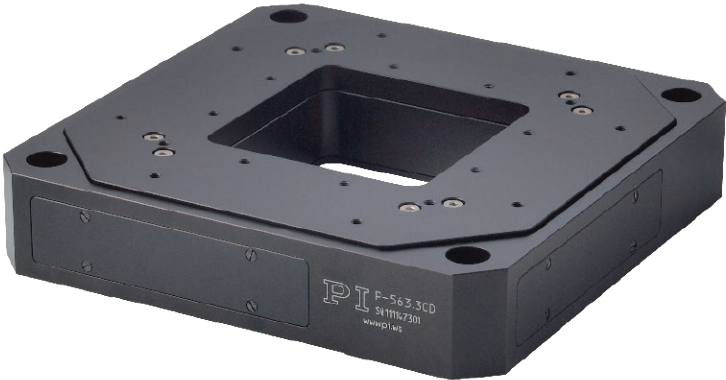

- Parallel kinematics / metrology for enhanced responsiveness and multi-axis precision
- Travel ranges to 300 × 300 × 300 μm
- Highest linearity due to capacitive sensors
- Zero-play, high-precision flexure guide system
- Excellent scanning flatness
- High-dynamics XYZ version available
- Clear aperture 66 mm × 66 mm
- Outstanding lifetime due to PICMA® piezo actuators
- UHV versions to 10⁻⁹ hPa

P-561.3DD, dimensions in mm.

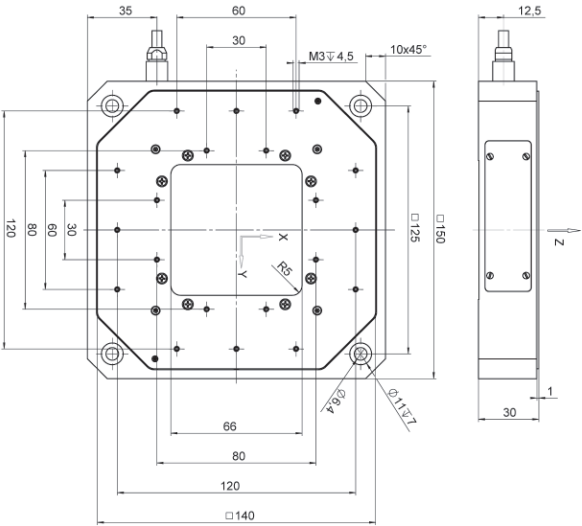

P-56x.3CD and P-56x.3CL, dimensions in mm

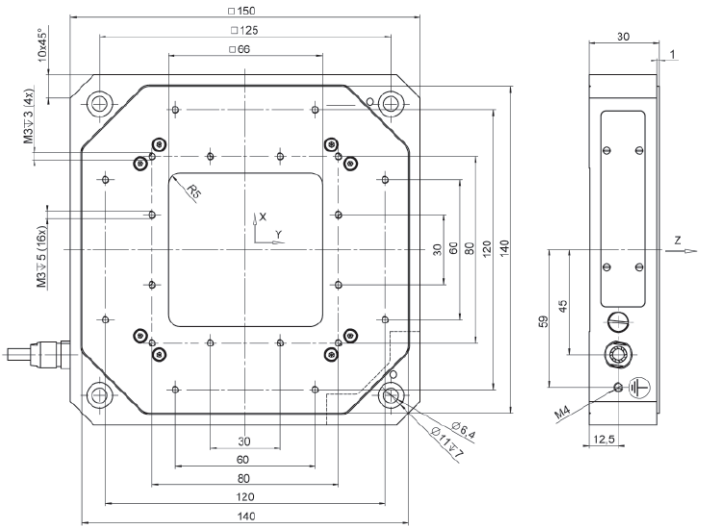

Applications

- Scanning microscopy
- Mask/wafer positioning
- Interferometry
- Metrology
- Biotechnology
- Scanning and screening

- >> Capacitive Feedback Sensors
- >> Flexure Guiding Systems
- >> Parallel Metrology
- >> PICMA® Multilayer Piezo Actuators
- >> Vacuum-Compatible Version

Technology Glossary page 240

	P-561.3CD P-561.3CL	P-562.3CD P-562.3CL	P-563.3CD P-563.3CL	P-561.3DD	Unit	Tolerance
PIMars XYZ piezo-nanopositioning system, closed-loop travel	100 × 100 × 100	200 × 200 × 200	300 × 300 × 300	45 × 45 × 15, direct drive	µm	
Motion and positioning						
Integrated sensor	Capacitive	Capacitive	Capacitive	Capacitive		
Open-loop travel, -20 to 120 V	150 × 150 × 150	300 × 300 × 300	340 × 340 × 340	58 × 58 × 18	µm	+20 % / -0 %
Open-loop resolution	0.2	0.4	0.5	0.1	nm	typ.
Closed-loop resolution	0.8	1	2	0.2	nm	typ.
Linearity error	0.03	0.03	0.03	0.01*	%	typ.
Repeatability in X / Y / Z	2 / 2 / 2	2 / 2 / 4	2 / 2 / 4	2 / 2 / 2	nm	typ.
Pitch in X, Y	±1	±2	±2	±3	µrad	typ.
Crosstalk θ_x, θ_y (motion in Z)	±15	±20	±25	±3	µrad	typ.
Yaw in X, Y	±6	±10	±10	±3	µrad	typ.
Flatness in X, Y	±15	±20	±25	±10	nm	typ.
Crosstalk in X, Y (motion in Z)	±30	±50	±50	±20	nm	typ.
Mechanical properties						
Unloaded resonant frequency in X / Y / Z	190 / 190 / 380	160 / 160 / 315	140 / 140 / 250	920 / 920 / 1050	Hz	±20 %
Resonant frequency at 100 g in X / Y / Z	-	145 / 145 / 275	120 / 120 / 215	860 / 860 / 950	Hz	±20 %
Resonant frequency at 330 g in X / Y / Z	140 / 140 / 300	130 / 130 / 195	110 / 110 / 170	500 / 500 / 470	Hz	±20 %
Load capacity**	5	5	5	5	kg	max.
Drive properties						
Piezo ceramic	PICMA® P-885	PICMA® P-885	PICMA® P-885	PICMA® P-885 in Z, P-888 in XY		
Electrical capacitance in X / Y / Z	5.2 / 5.2 / 10.4	7.4 / 7.4 / 14.8	7.4 / 7.4 / 14.8	38 / 38 / 6	µF	±20 %
Miscellaneous						
Operating temperature range	-20 to 80	-20 to 80	-20 to 80	-20 to 80	°C	
Material	Aluminum	Aluminum	Aluminum	Aluminum		
Mass	1.45	1.45	1.45	1.55	kg	±5 %
Sensor / voltage connection	CD version: Sub-D 25W3 (m), 1.5 m cable CL version: LEMO	CD version: Sub-D 25W3 (m), 1.5 m cable CL version: LEMO	CD version: Sub-D 25W3 (m), 1.5 m cable CL version: LEMO	CD version: Sub-D 25W3 (m), 1.5 m cable CL version: LEMO		
Recommended electronics	E-503, E-505, E 621, E-712, E 727	E-503, E-505, E 621, E-712, E 727	E-503, E-505, E 621, E-712, E 727	E-503, E-505, E 621, E-712, E 727		

* With digital controller. Nonlinearity of direct drive stages measured with analog controllers is up to 0.1 % typ.

** When mounted horizontally (standing on a surface, not suspended).

The resolution of PI piezo nanopositioning systems is not limited by friction or stiction.

Value given is noise equivalent motion with E-725 / E-712 controller.

All specifications based on room temperature (22 °C ±3 °C).

Super-invar and titanium versions available.

Ask about custom designs!

P-517 / P-527 Multi-Axis Piezo Scanner

High-Dynamics Nanopositioner / Scanner with Direct Position Measuring

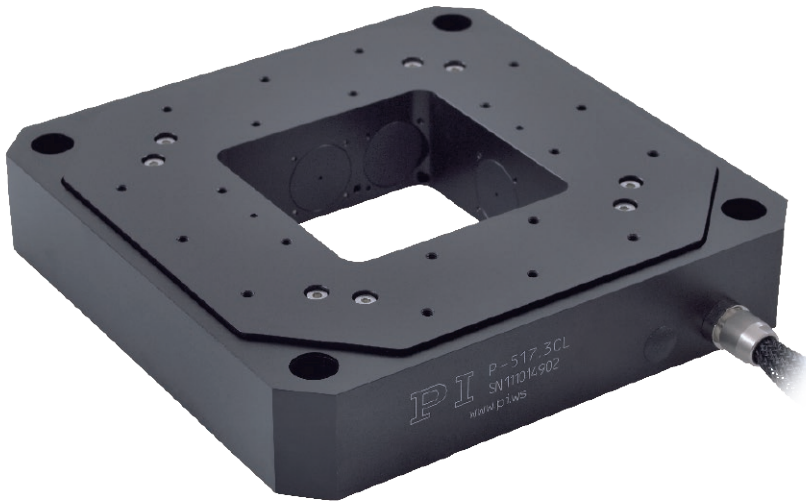

- 2- and 3-axis versions (XY and XY θ_z)
- Travel ranges to 200 μm
- Subnanometer resolution

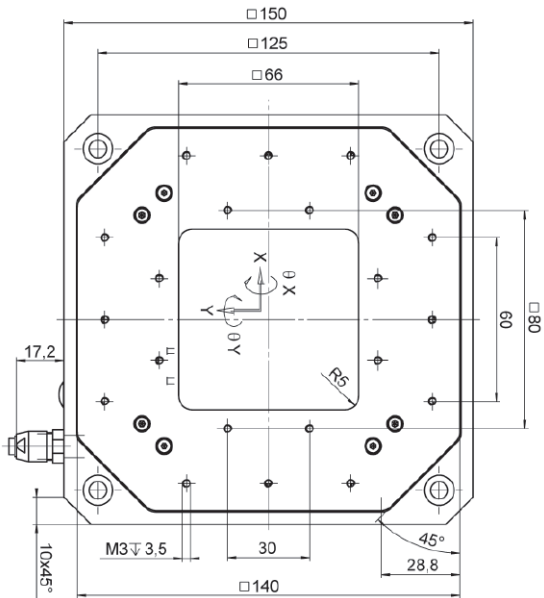

P-517, P-527, dimensions in mm.

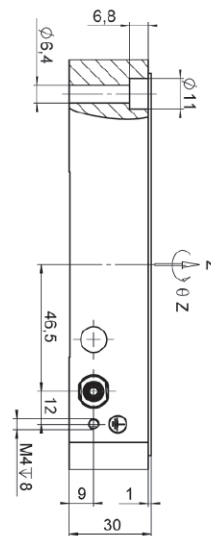

Applications

- Metrology
- Interferometry
- Photonics / integrated optics
- Lithography
- Nanopositioning
- Scanning microscopy
- Sample alignment;
- Micromachining

- >> Capacitive Feedback Sensors
- >> Flexure Guiding Systems
- >> Parallel Metrology
- >> PICMA® Multilayer Piezo Actuators

Technology Glossary page 240

	P-517.2CL / P-517.2CD	P-527.2CL / P-527.2CD	P-517.3CL / P-517.3CD	P-527.3CL / P-527.3CD	P-517.RCD	P-527.RCD	Unit	Tolerance
Active axes	X, Y	X, Y	X, Y, Z	X, Y, Z	X, Y, θ_z	X, Y, θ_z		
Motion and positioning								
Integrated sensor	Capacitive	Capacitive	Capacitive	Capacitive	Capacitive	Capacitive		
Open-loop travel range, -20 to 120 V	130 μm	250 μm	X, Y: 130 μm Z: 25 μm	X, Y: 250 μm Z: 25 μm	X, Y: 130 μm θ_z : ± 1.3 mrad	X, Y: 250 μm θ_z : ± 2.5 mrad		+20 % / -0 %
Closed-loop travel range	100 μm	200 μm	X, Y: 100 μm Z: 20	X, Y: 200 μm Z: 20	X, Y: 100 μm θ_z : ± 1 mrad	X, Y: 200 μm θ_z : ± 2 mrad		
Resolution, open loop	0.3 nm	0.5 nm	X, Y: 0.3 nm Z: 0.1 nm	X, Y: 0.5 nm Z: 0.1 nm	X, Y: 0.3 nm θ_z : 0.1 μrad	X, Y: 0.5 nm θ_z : 0.1 μrad		typ.
Resolution, closed loop	1 nm	2 nm	X, Y: 1 nm Z: 0.1 nm	X, Y: 2 nm Z: 0.1 nm	X, Y: 1 nm θ_z : 0.3 μrad	X, Y: 2 nm θ_z : 0.3 μrad		typ.
Linearity error	0.03	0.03	0.03	0.03	0.03	0.03	%	typ.
Repeatability	± 5 nm	± 10 nm	X, Y: ± 5 nm Z: ± 1 nm	X, Y: ± 10 nm Z: ± 1 nm	X, Y: ± 5 nm θ_z : ± 0.5 μrad	X, Y: ± 10 nm θ_z : ± 1 μrad		typ.
Mechanical properties								
Stiffness	2	1	X, Y: 2 Z: 15	X, Y: 1 Z: 15	2	1	N/ μm	± 20 %
Resonant frequency, no load	450	350	X, Y: 450 Z: 1100	X, Y: 350 Z: 1100	X, Y: 450 θ_z : 400	X, Y: 350 θ_z : 300	Hz	± 20 %
Resonant frequency under load in X, Y, 500 g	250	190	250	190	250	190	250	190
Resonant frequency under load in X, Y, 2500 g	140	110	140	110	140	110	140	110
Load capacity*	5	5	5	5	5	5	5	5
Drive properties								
Piezo ceramic	PICMA® P-885	PICMA® P-885	PICMA® P-885	PICMA® P-885	PICMA® P-885	PICMA® P-885		
Electrical capacitance	9.2	9.2	X, Y: 9 Z: 6	X, Y: 9 Z: 6	9	9	μF	± 20 %
Miscellaneous								
Operating temperature range	-20 to 80	-20 to 80	-20 to 80	-20 to 80	-20 to 80	-20 to 80	°C	
Material	Aluminum	Aluminum	Aluminum	Aluminum	Aluminum	Aluminum		
Mass	1.4	1.4	1.45	1.45	1.4	1.4	kg	± 5 %
Sensor / voltage connection	CL version: LEMO Sub-D 25W3 (m)	CL version: LEMO Sub-D 25W3 (m)	CL version: LEMO Sub-D 25W3 (m)	CL version: LEMO Sub-D 25W3 (m)	Sub-D 25W3 (m)	Sub-D 25W3 (m)		
Recommended electronics	E-503, E-505, E-621, E-712, E-727	E-503, E-505, E-621, E-712, E-727	E-503, E-505, E-621, E-712, E-727	E-503, E-505, E-621, E-712, E-727	E-503, E-505, E-621, E-712, E-727	E-503, E-505, E-621, E-712, E-727		

* When mounted horizontally (standing on a surface, not suspended).

The resolution of PI piezo nanopositioning systems is not limited by friction or stiction. Specification is position noise with the E-503 piezo amplifier module or E-710 digital piezo controller. All specifications based on room temperature (22 °C \pm 3 °C).

P-518 / P-528 / P-558 Piezo Z / Tip / Tilt Stage

High Dynamics, with Large Aperture

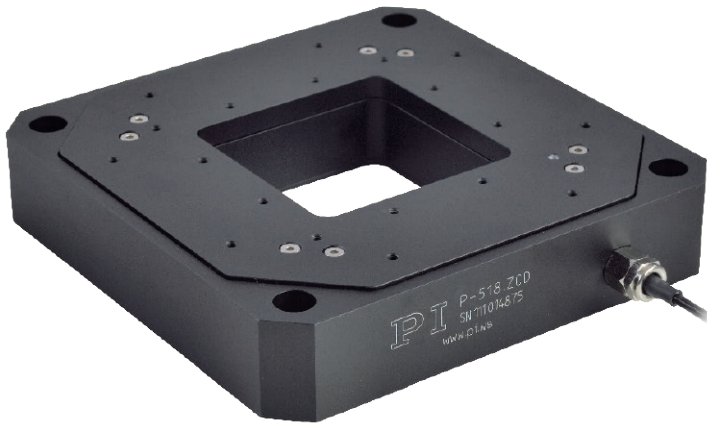

- Z and tip / tilt stages with 3 axes / Z stages with 1 axis
- Closed-loop vertical / tilt range to 200 μm / 2 mrad (open-loop to 240 μm / 2.4 mrad)
- Parallel kinematics for faster response times and higher multi-axis accuracy
- Zero-play, high-precision flexure guide system
- Outstanding lifetime due to PICMA[®] piezo actuators
- Clear aperture 66 mm \times 66 mm
- Highest linearity due to capacitive sensors

P-518 / P-528 / P-558 Z stage, dimensions in mm.

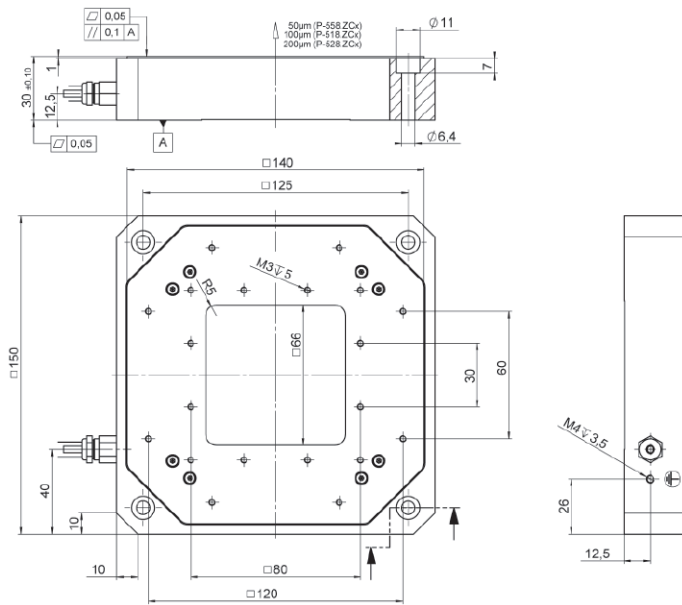

P-518 / P-528 / P-558 Z and tip / tilt stage, dimensions in mm.

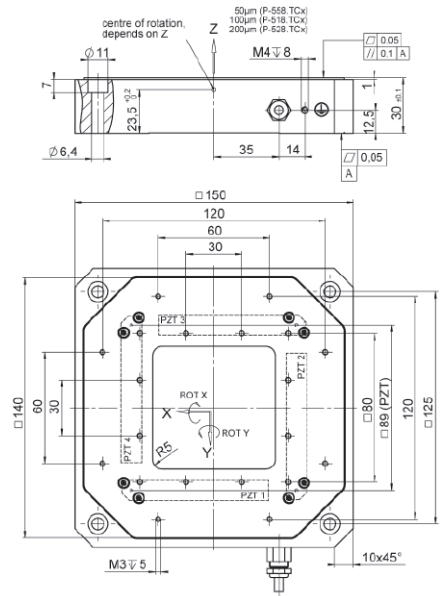

Applications

- Metrology
- Interferometry
- Photonics / integrated optics
- Lithography
- Nanopositioning
- Scanning microscopy
- Sample alignment;
- Micromachining

- >> Capacitive Feedback Sensors
- >> Flexure Guiding Systems
- >> Parallel Metrology
- >> PICMA[®] Multilayer Piezo Actuators

Technology Glossary page 240

	P-558.ZCD / P-558.ZCL	P-558.TCD	P-518.ZCD / P-518.ZCL	P-518.TCD	P-528.ZCD / P-528.ZCL	P-528.TCD	Unit	Tolerance
Active axes	Z	Z, θ_x , θ_y	Z	Z, θ_x , θ_y	Z	Z, θ_x , θ_y		
Motion and positioning								
Integrated sensor	Capacitive	Capacitive	Capacitive	Capacitive	Capacitive	Capacitive		
Travel range in Z at -20 to 120 V, open loop	60	60	140	140	240	240	μm	+20 % / -0 %
Tip / tilt angle in θ_x , θ_y at -20 to 120 V, open loop	-	± 0.3	-	± 0.7	-	± 1.2	mrad	+20 % / -0 %
Travel range in Z, closed loop	50	50	100	100	200	200	μm	
Tip / tilt angle in θ_x , θ_y , closed loop	-	± 0.25	-	± 0.5	-	± 1	mrad	
Resolution in Z, open loop	0.2	0.2	0.2	0.4	0.6	0.6	nm	typ.
Resolution in θ_x , θ_y , open loop	-	0.02	-	0.04	-	0.06	μrad	typ.
Resolution in Z, closed loop	0.5	0.5	0.8	0.8	1	1	nm	typ.
Resolution in θ_x , θ_y , closed loop	-	0.05	-	0.05	-	0.1	μrad	typ.
Linearity error in θ_x , θ_y	-	0.03	-	0.03	-	0.03	%	typ.
Repeatability in Z	± 5	± 5	± 5	± 5	± 10	± 10	nm	typ.
Repeatability in θ_x , θ_y	-	± 0.03	-	± 0.05	-	± 0.1	μrad	typ.
Crosstalk θ_Z (motion in Z)	<10	<10	<10	<10	<20	<20	μrad	typ.
Crosstalk θ_x , θ_y (motion in Z)	<50	<50	<50	<50	<100	<100	μrad	typ.
Mechanical properties								
Stiffness in Z	4	4	2.7	2.7	1.5	1.5	N/ μm	± 20 %
Resonant frequency in Z, no load	570	570	500	500	350	350	Hz	± 20 %
Resonant frequency in θ_x , θ_y , no load	-	610	-	530	-	390	Hz	± 20 %
Resonant frequency in Z, under load, 500 g	410	410	350	350	210	210	Hz	± 20 %
Resonant frequency in θ_x , θ_y , under load 500 g	-	430	-	370	-	250	Hz	± 20 %
Resonant frequency in Z, under load, 2500 g	245	245	200	200	130	130	Hz	± 20 %
Resonant frequency in θ_x , θ_y , under load, 2500 g	-	240	-	190	-	115	Hz	± 20 %
Load capacity*	5	5	5	5	5	5	kg	max.
Drive properties								
Piezo ceramic	PICMA® P-885	PICMA® P-885	PICMA® P-885	PICMA® P-885	PICMA® P-885	PICMA® P-885		
Electrical capacitance	6	6	8.4	8.4	14.8	14.8	μF	± 20 %
Miscellaneous								
Operating temperature range	-20 to 80	-20 to 80	-20 to 80	-20 to 80	-20 to 80	-20 to 80	°C	
Material	Aluminum	Aluminum	Aluminum	Aluminum	Aluminum	Aluminum		
Dimensions	150 mm x 150 mm x 30 mm	150 mm x 150 mm x 30 mm	150 mm x 150 mm x 30 mm	150 mm x 150 mm x 30 mm	150 mm x 150 mm x 30 mm	150 mm x 150 mm x 30 mm		
Mass	1380	1380	1400	1400	1420	1420	g	± 5 %
Cable length	1.5	1.5	1.5	1.5	1.5	1.5	m	± 10 mm
Sensor / voltage connection	CL version: LEMO CD version: Sub-D 7W2 (m)	ub-D 25W3 (m)	CL version: LEMO CD version: Sub-D 7W2 (m)	Sub-D 25W3 (m)	CL version: LEMO CD version: Sub-D 7W2 (m)	Sub-D 25W3 (m)		
Recommended electronics	E-503, E-505, E-610, E-621, E-625, E-712, E-727, E-754	E-503, E-505, E-610, E-621, E-625, E-712, E-727, E-754	E-503, E-505, E-610, E-621, E-625, E-712, E-727, E-754	E-503, E-505, E-610, E-621, E-625, E-712, E-727, E-754	E-503, E-505, E-610, E-621, E-625, E-712, E-727, E-754	E-503, E-505, E-610, E-621, E-625, E-712, E-727, E-754		

* When mounted horizontally (standing on a surface, not suspended).

The resolution of PI piezo nanopositioning systems is not limited by friction or stiction. Specification as position noise with the E-503 piezo amplifier module or E-710 digital piezo controller.

All specifications based on room temperature (22 °C \pm 3 °C).

Ask about custom designs!

P-541.Z Piezo Z and Z / Tip / Tilt Stages

Low Profile, Large Aperture



- Low profile for easy integration: 16.5 mm
- Clear aperture 80 mm x 80 mm
- Vertical and Z / tip / tilt stages
- Travel range 100 μm
- 1 mrad tilt
- Parallel kinematics for faster response times and higher multi-axis accuracy
- Choice of sensors: Strain gauge (lower cost) or capacitive sensors (higher performance)
- Outstanding lifetime due to PICMA[®] piezo actuators
- Combination with long-travel microscopy stages

P-541.Z0L, dimensions in mm.

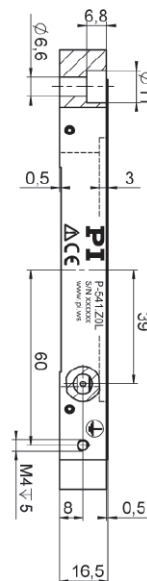
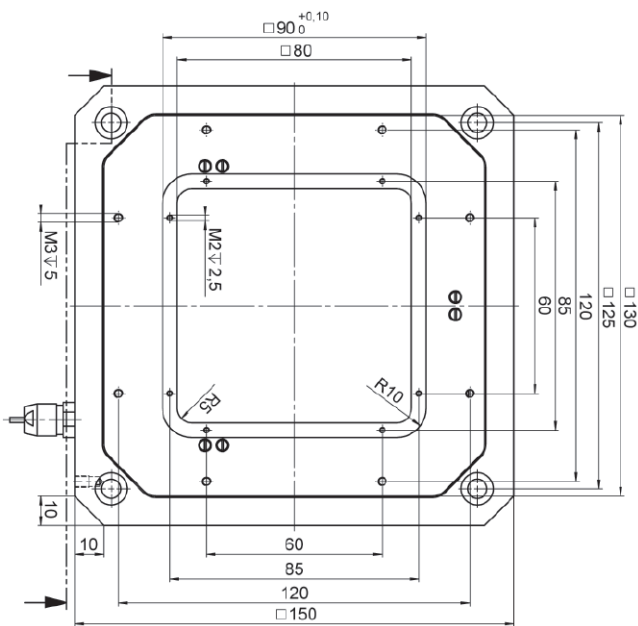

Applications

- Scanning microscopy
- Super-resolution microscopy
- Biotechnology
- Mask / wafer positioning
- Sample positioning
- Interferometry
- Metrology

- >> Capacitive Feedback Sensors
- >> Flexure Guiding Systems
- >> Parallel-Kinematic Piezo Stages
- >> PICMA[®] Multilayer Piezo Actuators

Technology Glossary page 240

	P-541.ZCD	P-541.TCD*	P-541.ZSL	P-541.TSL*	P-541.ZOL	P-541.TOL*	Unit	Tolerance
Active axes	Z	Z, θ_x , θ_y	Z	Z, θ_x , θ_y	Z	Z, θ_x , θ_y		
Motion and positioning								
Integrated sensor	Capacitive	Capacitive	SGS	SGS	Open-loop	Open-loop		
Open-loop Z-travel, -20 to 120 V	150	150	150	150	150	150	μm	+20 % / -0 %
Open-loop tip / tilt angle in θ_x , θ_y at -20 to 120 V	–	± 0.6	–	± 0.6	–	± 0.6	mrad	+20 % / -0 %
Closed-loop Z-travel	100	100	100	100	–	–	μm	
Closed-loop tip / tilt angle in θ_x , θ_y	–	± 0.4	–	± 0.4	–	–	mrad	
Open-loop Z-resolution	0.2	0.2	0.2	0.2	0.2	0.2	nm	typ.
Open-loop resolution in θ_x , θ_y	–	0.02	–	0.02	–	0.02	μrad	typ.
Closed-loop Z-resolution	0.5	0.5	2.5	2.5	–	–	nm	typ.
Closed-loop resolution in θ_x , θ_y	–	0.08	–	0.25	–	–	μrad	typ.
Linearity error (Z-travel), θ_x , θ_y	0.03	0.03	0.2	0.2	–	–	%	typ.
Repeatability Z	<2	<2	<10	<10	–	–	nm	typ.
Repeatability θ_x , θ_y	–	0.01	–	0.05	–	–	μrad	typ.
Runout θ_x , θ_y (motion in Z)	± 15	± 15	± 15	± 15	± 15	± 15	μrad	typ.
Mechanical properties								
Stiffness Z	0.8	0.8	0.8	0.8	0.8	0.8	N/ μm	± 20 %
Unloaded resonant frequency (Z)	410	410	410	410	410	410	Hz	± 20 %
Unloaded resonant frequency θ_x , θ_y	–	330	–	330	–	330	Hz	± 20 %
Resonant frequency at 200 g (Z)	250	250	250	250	250	250	Hz	± 20 %
Resonant frequency at 200 g, θ_x , θ_y	–	270	–	270	–	270	Hz	± 20 %
Push / pull force capacity	50 / 20	50 / 20	50 / 20	50 / 20	50 / 20	50 / 20	N	max.
Drive properties								
Ceramic type	PICMA® P-885	PICMA® P-885	PICMA® P-885	PICMA® P-885	PICMA® P-885	PICMA® P-885		
Electrical capacitance	6.3	6.3	6.3	6.3	6.3	6.3	μF	± 20 %
Miscellaneous								
Operating temperature range	20 to 80	20 to 80	20 to 80	20 to 80	20 to 80	20 to 80	°C	
Material	Aluminum	Aluminum	Aluminum	Aluminum	Aluminum	Aluminum		
Mass	750	750	730	730	700	700	g	± 5 %
Cable length	1.5	1.5	1.5	1.5	1.5	1.5	m	± 10 mm
Sensor connection	Sub-D 7W2 (m)	Sub-D 25W3 (m)	LEMO	3 × LEMO	–	–		
Voltage connection	Sub-D 7W2 (m)	Sub-D 25W3 (m)	LEMO	3 × LEMO	LEMO	3 × LEMO		
Recommended electronics	E 503, E 505, E 610, E 621, E 625, E 712, E 727, E 754	E 503, E 505, E 610, E 621, E 625, E 712, E 727, E 754	E 503, E 505, E 610, E 621, E 625, E 712, E 727, E 754	E 503, E 505, E 610, E 621, E 625, E 712, E 727, E 754	E 503, E 505, E 610, E 621, E 625, E 712, E 727, E 754	E 503, E 505, E 610, E 621, E 625, E 712, E 727, E 754		

* Parallel kinematics design; the maximum displacement for translation and tilt motion cannot be achieved at the same time.
Resolution of PI piezo nanopositioners is not limited by friction or stiction. Value given is noise equivalent motion with E-503 or E-710 controller.
All specifications based on room temperature (22 °C \pm 3 °C).

P-562.6CD PIMars 6-Axis Piezo Stage System

High-Precision Nanopositioning System with 6 Degrees of Freedom

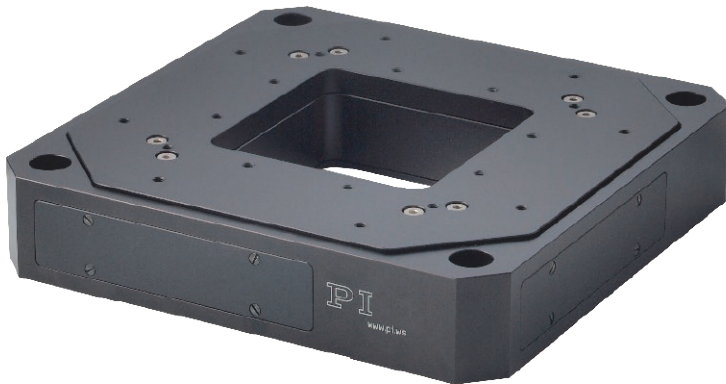

- 6 motion axes: 3 × linear, 3 × rotational
- Travel ranges to 200 μm linear and to 1 mrad tilt angle
- Parallel kinematics for faster response times and higher multi-axis accuracy
- Highest linearity due to capacitive sensors
- Zero-play, high-precision flexure guide system
- Excellent scan-flatness
- Clear aperture 66 mm × 66 mm
- Outstanding lifetime due to PICMA® piezo actuators
- UHV-compatible to 10⁻⁹ hPa

P-562, dimensions in mm.

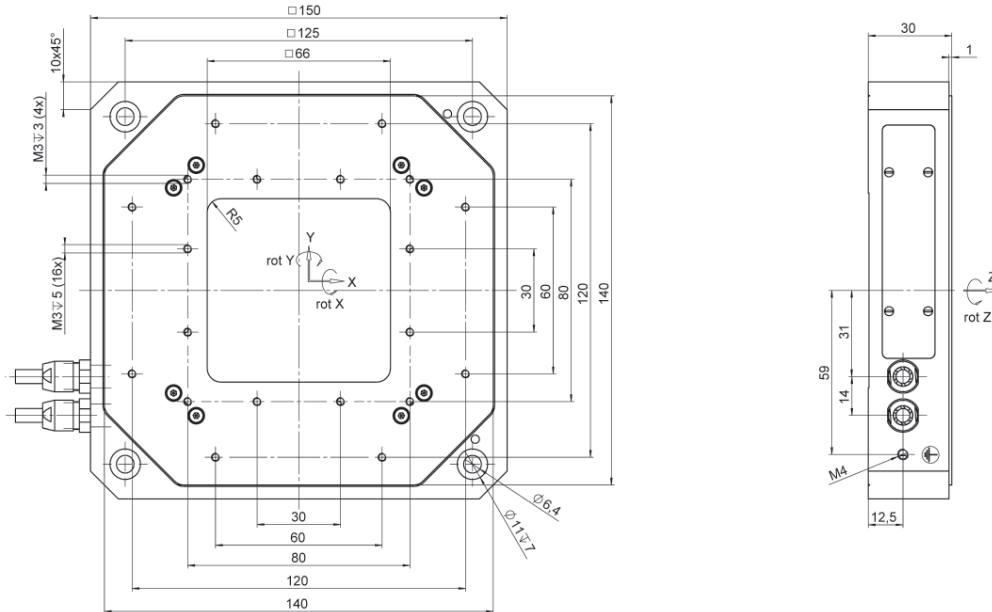

Applications

- Scanning microscopy
- Super-resolution microscopy
- Biotechnology
- Mask / wafer positioning
- Sample positioning
- Interferometry
- Metrology

- >> Capacitive Feedback Sensors
- >> Flexure Guiding Systems
- >> Parallel Metrology
- >> PICMA® Multilayer Piezo Actuators
- >> Vacuum-Compatible Version

Technology Glossary page 240

	P-562.6CD	Unit	Tolerance
Active axes	X, Y, Z, θ_x , θ_y , θ_z		
Motion and positioning			
Integrated sensor	Capacitive		
Closed-loop travel in X, Y, Z	200	μm	
Closed-loop tilt angle in θ_x , θ_y , θ_z	± 0.5	mrad	
Closed-loop resolution X, Y, Z	1	nm	typ.
Closed-loop resolution in θ_x , θ_y , θ_z	0.1	μrad	typ.
Linearity error in X, Y, Z	0.01	%	typ.
Linearity error θ_x , θ_y , θ_z	0.1	%	typ.
Repeatability in X / Y / Z	$\pm 2 / \pm 2 / \pm 3$	nm	typ.
Repeatability θ_x , θ_y , θ_z	$\pm 0.1 / \pm 0.1 / \pm 0.15$	μrad	typ.
Flatness	<15	nm	typ.
Unloaded resonant frequency in X / Y / Z	110 / 110 / 190	Hz	± 20 %
Load capacity*	5	kg	max.
Drive properties			
Ceramic type	PICMA®		
Electrical capacitance in X / Y / Z	7.4 / 7.4 / 14.8	μF	± 20 %
Miscellaneous			
Operating temperature range	-20 to 80	$^{\circ}\text{C}$	
Material	Aluminum		
Mass	1.45	kg	± 5 %
Cable length	1.5	m	± 10 mm
Sensor / voltage connection	2 × Sub-D 25W3 (m)		
Recommended electronics	E-712		

* When mounted horizontally (standing on a surface, not suspended).

The resolution of PI piezo nanopositioning systems is not limited by friction or stiction. Specification is position noise with the E-503 piezo amplifier module or E-710 digital piezo controller.

All specifications based on room temperature ($22\text{ }^{\circ}\text{C} \pm 3\text{ }^{\circ}\text{C}$).

Other travel ranges on request.

P-587 6-Axis Precision Piezo Stage

Long Scanning Range, Direct Position Measurement



- For scanning and positioning in X, Y, Z, θ_x , θ_y , θ_z
- 800 μm \times 800 μm \times 200 μm linear range
- Up to 1 mrad rotational angle
- Parallel kinematics for faster response times and higher multi-axis accuracy
- Direct metrology with capacitive sensors for highest linearity
- Outstanding lifetime due to PICMA[®] piezo actuators
- Zero-play, high-precision flexure guide system
- Active trajectory control in all 6 degrees of freedom

P-587, dimensions in mm.

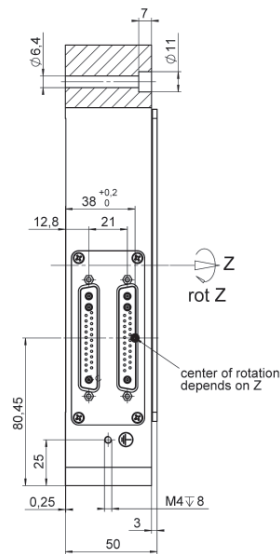
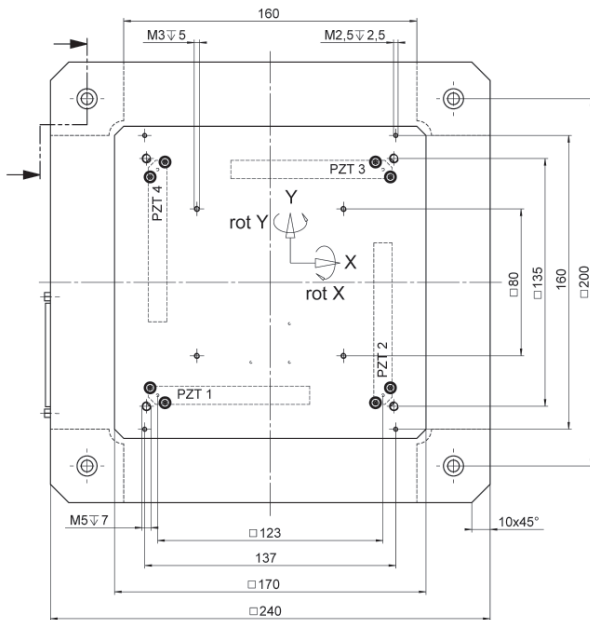

Applications

- Interferometry
- Metrology
- Nano-imprinting
- Semiconductor testing
- Semiconductor production

- >> Capacitive Feedback Sensors
- >> Direct Metrology
- >> Flexure Guiding Systems
- >> PICMA[®] Multilayer Piezo Actuators
- >> Vacuum-Compatible Version

Technology Glossary page 240

	P-587.6CD	Unit	Tolerance
Active axes	X, Y, Z, θ_x , θ_y , θ_z		
Motion and positioning			
Integrated sensor	Capacitive		
Closed-loop travel in X, Y	800	μm	
Closed-loop travel in Z	200	μm	
Closed-loop tilt angle in θ_x , θ_y	± 0.5	mrad	
Closed-loop tilt angle in θ_z	± 0.5	mrad	
Open-loop / closed-loop resolution X, Y	0.9 / 2.2	nm	typ.
Open-loop / closed-loop resolution Z	0.4 / 0.7	nm	typ.
Open-loop / closed-loop resolution in θ_x , θ_y	0.05 / 0.1	μrad	typ.
Open-loop / closed-loop resolution in θ_z	0.1 / 0.3	μrad	typ.
Linearity error in X, Y, Z	0.01	%	typ.
Linearity error θ_x , θ_y , θ_z	0.1	%	typ.
Repeatability X, Y	± 3	nm	typ.
Repeatability in Z	± 2	nm	typ.
Repeatability in θ_x , θ_y	± 0.1	μrad	typ.
Repeatability in θ_z	± 0.15	μrad	typ.
Flatness	<15	nm	typ.
Stiffness in X / Y / Z	0.55 / 0.55 / 1.35	N / μm	
Unloaded resonant frequency in X / Y / Z	103 / 103 / 235	Hz	± 20 %
Resonant frequency at 500 g in X / Y / Z	88 / 88 / 175	Hz	± 20 %
Resonant frequency at 2000 g in X / Y / Z	65 / 65 / 118	Hz	± 20 %
Load capacity*	5	kg	max.
Drive properties			
Ceramic type	PICMA®		
Electrical capacitance in X / Y / Z	81 / 81 / 18.4	μF	± 20 %
Miscellaneous			
Operating temperature range	-20 to 80	$^{\circ}\text{C}$	
Material	Aluminum		
Dimensions	240 mm x 240 mm x 50 mm		
Mass	7.2	kg	± 5 %
Cable length	1.5	m	± 10 mm
Sensor / voltage connection	2 x Sub-D 25W3 (m)		
Recommended electronics	E-712		

* When mounted horizontally (standing on a surface, not suspended).

The maximum rotational angle in Z is 8 mrad, the tilt angles around X and Y rate 3 mrad.

Due to the parallel kinematics design, linear motion in X or Y is not possible simultaneously when the stage is in extreme tilt angle position.

The resolution of PI piezo nanopositioning systems is not limited by friction or stiction.

Specification is position noise with the E-503 piezo amplifier module or E-710 digital piezo controller.

All specifications based on room temperature (22 $^{\circ}\text{C}$ ± 3 $^{\circ}\text{C}$).

Scanners for Microscopy



Microscopy Solutions	78
-----------------------------------	-----------

PIFOC Objective Scanners	80
ND72Z2LAQ PIFOC Objective Scanning System 2000 μm	80
PD72Z2x/4x PIFOC Objective Scanning System 400 μm	82
PD72Z1x PIFOC Objective Scanning System 100 μm	84
P-725 PIFOC Objective Scanner with Long Travel Range	86
P-725.xDD PIFOC High-Dynamics Piezo Scanner	88
P-726 PIFOC High-Load Objective Scanner	90
P-721 PIFOC Piezo Flexure Objective Scanner	92

Vertical Sample Stages for Microscopys	94
P-736 Plnano [®] Z Microscope Scanner	94
P-737 PIFOC Specimen-Focusing Z Stage	96

Plnano[®] Piezo Flexure XY(Z) Scanners	98
P-545.3D8S Plnano [®] Trak Piezo Tracking System	98
P-545.xR8S Plnano [®] XY(Z) Piezo System	100
P-545.xC8S Plnano [®] Cap XY(Z) Piezo System	102

Microscopy Solutions



Piezo stages are ideal for moving the objective (PIFOC, top) and / or the sample (XYZ sample scanning, middle). The small-stroke piezo stages can be supplemented by low-profile PLine® Scanning Stages for large travel ranges (bottom)

Positioning Tasks in Microscopy

Modern microscopic techniques have some similar basic requirements in regard to the positioning elements: compact design and very high accuracy which refers to precision positioning, high repeatability and short settling time. For example, Z-stacks of samples are realized by many individual images in as short a time as possible to avoid damage of the biological cells. Next to that, the observation of dynamic processes is an important application scenario as well – both tasks place great demands on the dynamics of the stage itself.

Sample or Objective?

Fast focusing in the direction of the optical axis can be done by moving the objective, for example. PIFOC systems with their easily exchangeable PI QuickLock thread inserts, and large apertures, offer up to 2000 μm of travel for the objective or turret. Z stack acquisition, autofocus / focus tracking or drift compensation are typical use cases.

Sample fine positioning can be enhanced by offering additional motion in XY for high-dynamic tracking, e.g. to examine motion of individual molecules. Plnano® tracking stages offer XYZ motion in one compact package.

Long Range PLine® XY Scanning Stages

Automated tasks require positioning over larger ranges of approx. 130 mm \times 80 mm with high speed and precision. PLine® stages are characterized by a low profile, an extremely large dynamic range (10 $\mu\text{m/s}$ to 100 mm/s) and very good velocity constancy, position stability and repeatability. These stages are also very well suited for super resolution microscopy applications such as STORM, PALM, STED or SIM, which place very high demands on the stability.

See details on the PI website (www.pi.ws).

System Packages?

Preconfigured packages that include the appropriate controller and software are available for the major product lines. PI piezo controllers come with high resolution digital interfaces (USB, Ethernet, RS-232), high-speed analog interfaces, as well as solid software support for all major image acquisition packages.

Compatibility of Piezo Scanners with Manual, Motorized and PLine® XY Microscope Stages

	P-545.xR8S P-545.xC8S P-545.3D8S PInano® piezo system	P-736.ZCN2S P-736.ZRN2S PInano® Z piezo scanner system	PD73Z2COW PD73Z2ROW PInano® Z piezo scanner system	P-736.ZR1S P-736.ZR2S PInano® Z piezo slide scanner system	P-733.2xx P-733.3xx Piezo nanopositioning stage	P-541.2xx / P-541.Txx P-541.Zxx / P-542.2xx Piezo nanopositioning stage	P-737.xxx Pifoc specimen-focusing Z stage
U-780.DNS PLine® XY stage system for Nikon microscopes	•	•				•	•
U-780.DOS PLine® XY stage system for Olympus microscopes	•		•			•	•
U-780.DLS PLine® XY stage system for Leica microscopes	•					•	•
U-760.DNOS PLine® XY stage system for Nikon / Olympus microscopes	•			•*	•**	•	
M-545.2MN XY stage for Nikon microscopes TI series	•			•*	•**	•	
M-545.2MO XY stage for Olympus microscopes IX2, IX3	•			•*	•**	•	
M-545.2ML XY stage for Leica microscopes DMI series	•			•*	•**	•	
M-545.2MZ XY stage for Zeiss microscopes Axio Observer	•			•*	•**	•	

* With P-736.AP1 adapter plate / ** With P-733.AP1 adapter plate

Inserts for PI Sample Stages

	P-545.xR8S P-545.xC8S P-545.3D8S	P-736.ZCN2S P-736.ZRN2S	PD73Z2COW PD73Z2ROW	P-736.ZR1S P-736.ZR2S	P-541.2xx P-541.Txx P-541.Zxx P-542.2xx	P-737.xxx	U-780.DNS	U-780.DOS	U-780.DLS	U-760.DNOS	M-545.2MIN M-545.2MO M-545.2ML M-545.2MZ
Microscope slide holder	P-545.SH3*	P-736.SHN*	P-736.SHO*	P-545.SH3*		P-737.AP1*	P-736.SHN* P-736.SHO*	P-736.SHN* P-736.SHO*	P-736.SHN* P-736.SHO*	P-545.SH3* with M-545.SHP	P-545.SH3* with M-545.SHP
Petri dish holder	P-545.PD3	P-736.PDN	P-736.PDO	P-545.PD3	P-542.PD1	P-737.AP2	P-736.PDN P-736.PDO	P-736.PDN P-736.PDO	P-736.PDN P-736.PDO	P-545.PD3 with M-545.SHP adapter plate	P-545.PD3 with M-545.SHP adapter plate
Microtiter plate holder		P-736.WPN	P-736.WPO		P-542.SH1*		P-736.WPN P-736.WPO	P-736.WPN P-736.WPO	P-736.WPN P-736.WPO		
Universal holder		P-736.UHN*	M-687.AP1*				P-736.UHN* M-687.AP1*	P-736.UHN* M-687.AP1*	P-736.UHN* M-687.AP1*		
Universal holding plate	P-545.PP3			P-545.PP3						P-545.PP3 with M-545.SHP	P-545.PP3 with M-545.SHP

M-545.SHP adapter plate

* Also available: P-545.C18 Coverslip holder (for 18 mm x 18 mm coverslips), P-545.C22 (for 22 mm x 22 mm coverslips) and P-545.C25 (for 25 mm x 25 mm coverslips)

ND72Z2LAQ PIFOC Objective Scanning System 2000 μm

Nanometer Resolution and Fast Step-and-Settle



N-725.2A with M32 thread insert, dimensions in mm.

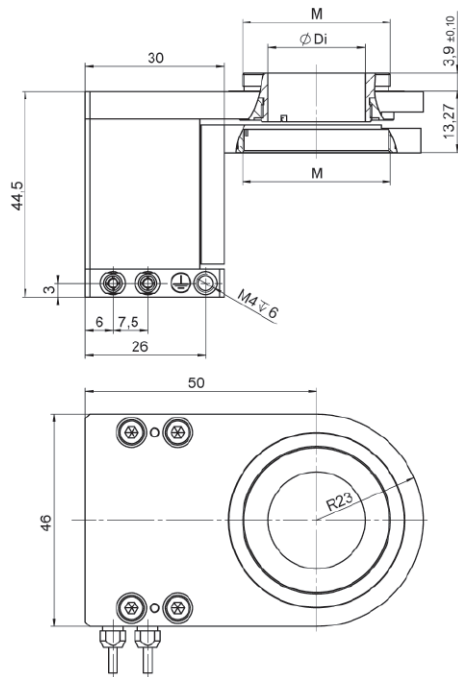

M	Di	Quicklock
M26 x 0,75	21	P-721.02Q
M27 x 0,75	21	P-721.03Q
M28 x 0,75	21	P-721.04Q
M32 x 0,75	21	P-721.05Q
M26 x 1/36"	21	P-721.06Q
M19 x 0,75	14	P-721.0SQ
M25 x 0,75	21	P-721.11Q
W0,8 x 1/36"	14	P-721.12Q

- Complete system with digital controller, software and M32 QuickLock thread insert
- USB, RS-232
- Sensor resolution 0.5 nm
- Highly dynamic step-and-settle for Z stacks
- Further thread adapters as optional accessory
- Compatible with μ Manager, MetaMorph and MATLAB
- Adaptation of all control parameters on the fly

Applications

- 2-photon microscopy
- Confocal microscopy
- 3D-Imaging
- Laser technology
- Interferometry
- Biotechnology
- Micromanipulation
- Autofocus for large travel ranges

- >> Extensive Software Package
- >> Incremental Encoder
- >> PiezoWalk® Walking Drive

Technology Glossary page 240

	ND72Z2LAQ	Unit	Tolerance
Active axes	Z		
Motion and positioning			
Integrated sensor	Optical linear encoder		
Closed-loop travel	2000	µm	
Min. incremental motion, closed-loop	5	nm	typ.
Mechanical properties			
Step-and-settle time for a 3 µm step at 200 g payload, 100 nm settling band	<20	ms	
Recommended load*	700	g	max.
Drive properties			
Piezoceramics	NEXACT®		
Miscellaneous			
Operating temperature range	15 to 40	°C	
Material	Aluminum		
Mass	290	g	±5 %
Cable length	1.5	m	±10 mm
Piezo controller	E-861 digital servo (included in delivery)		
Communication interfaces	USB, RS-232		
Connector (motor)	HD Sub-D 15-pin		
Connector (sensor)	HD Sub-D 15-pin		
I/O connector	4 × digital input (TTL, programmable)		
4 × digital output (TTL, programmable)			
Command set	PI General Command Set (GCS)		
User software	PIMikroMove		
Software drivers	LabVIEW driver, shared libraries for Windows and Linux. Supports MATLAB, MetaMorph, µManager		
Supported functionality	Wave generator, data recorder, macro programming		
Controller dimensions	160 mm × 96 mm × 33 mm		

* For dynamic operation. Higher dynamics are possible with a reduced load.
All specifications based on room temperature (22 °C ±3 °C).
Ask about custom designs!

Accessory included in delivery

P-721.05Q QuickLock-Thread adapter M32 × 0.75

Further accessories

P-721.02Q QuickLock-Thread adapter M26 × 0.75
P-721.03Q QuickLock-Thread adapter M27 × 0.75
P-721.04Q QuickLock-Thread adapter M28 × 0.75
P-721.06Q QuickLock-Thread adapter M26 × 1/36"
P-721.08Q QuickLock-Thread adapter M19 × 0.75
P-721.11Q QuickLock-Thread adapter M25 × 0.75
P-721.12Q QuickLock-Thread adapter W0.8 × 1/36"

PD72Z2x/4x PIFOC Objective Scanning System 400 μm

High-dynamics Piezo Drive for Sub-Nanometer Resolution



- Complete system with digital controller, software and QuickLock thread adapter
- USB, RS-232, analog interfaces
- Travel ranges to 400 μm
- Scans and positions objectives with sub-nanometer resolution
- Zero-play, high-precision flexure guide system
- Direct metrology with capacitive sensors
- Compatible with μManager, MetaMorph and MATLAB
- Adaptation of all control parameters on the fly

PD72ZxCAQ, dimensions in mm.
P-721.xxQ: Suitable PIFOC QuickLock thread adapters available.

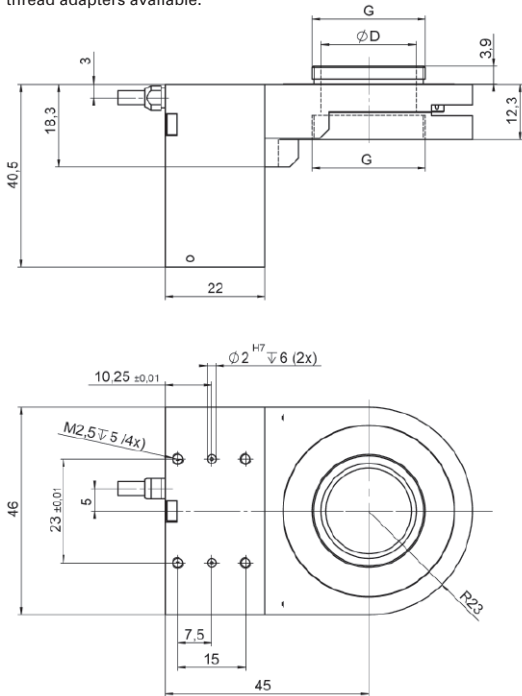

PD72ZxCAA, dimensions in mm.
P-721.xxA: Suitable PIFOC QuickLock thread adapters available.

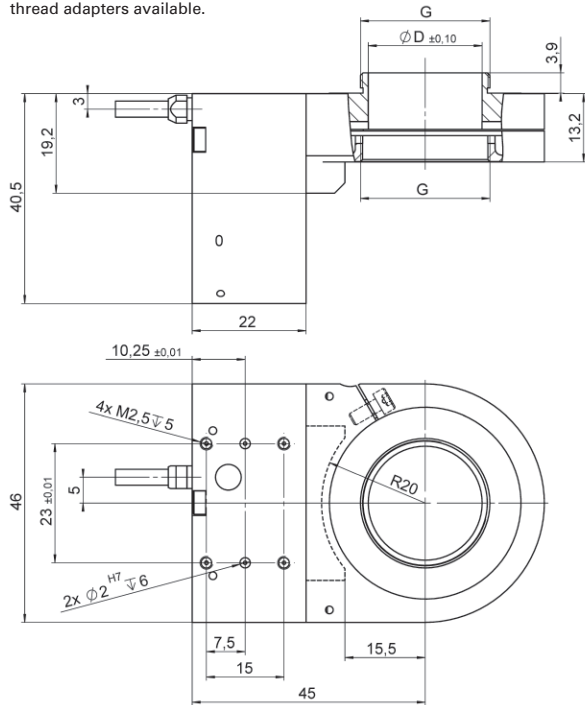

Applications

- Microscopy
- Confocal microscopy
- 3D-Imaging
- Screening
- Autofocus systems
- Surface analysis
- Wafer inspection
- Multi-photon microscopy

- >> Capacitive Sensors
- >> Direct Metrology
- >> Extensive Software Package

Technology Glossary page 240

	PD72Z2CAA / PD72Z2CAQ	PD72Z4CAA / PD72Z4CAQ	Units	Tolerance
Active axes	Z	Z		
Motion and positioning				
Integrated sensor	Capacitive	Capacitive		
Closed-loop travel	250	400	µm	
Closed-loop resolution	1.5	2.5	nm	typ.
Linearity, closed-loop	0.06	0.06	%	typ.
Repeatability	±5	±5	nm	typ.
Runout θ_x	6	10	µrad	typ.
Runout θ_y	45	45	µrad	typ.
Crosstalk in X	20	60	nm	typ.
Crosstalk in Y	40	60	nm	typ.
Settling time (0.5 µm step with 5 % accuracy, 150 g)	15	20	ms	typ.
Mechanical properties				
Stiffness in motion direction	0.17	0.12	N/µm	±20 %
Unloaded resonant frequency	330	230	Hz	±20 %
Resonant frequency at 150 g	140	120	Hz	±20 %
Push / pull force capacity in motion direction	100 / 20	100 / 20	N	max.
Drive properties				
Piezo ceramics	PICMA® P-885	PICMA® P-885		
Miscellaneous				
Operating temperature range	10 to 50	10 to 50	°C	
Material	Aluminum	Aluminum		
Mass	0.23	0.23	kg	±5 %
Cable length	1.5	1.5	m	
Piezo controller				
Communication interfaces	E-709 (included in delivery)	E-709 (included in delivery)		
I/O Connector	USB, RS-232	USB, RS-232		
I/O Connector	HD-Sub-D 26-pin 1 analog input 0 to 10 V 1 sensor monitor 0 to 10 V 1 digital input (LVTTTL, programmable) 5 digital outputs (LVTTTL, 3 predefined, 2 programmable)	HD-Sub-D 26-pin 1 analog input 0 to 10 V 1 sensor monitor 0 to 10 V 1 digital input (LVTTTL, programmable) 5 digital outputs (LVTTTL, 3 predefined, 2 programmable)		
Command set	PI General Command Set (GCS)	PI General Command Set (GCS)		
User software	PIMikroMove	PIMikroMove		
Software drivers	LabVIEW drivers, shared libraries for Windows and Linux	LabVIEW drivers, shared libraries for Windows and Linux		
Supported functionality	Wave generator, data recorder, auto zero, trigger I/O, MATLAB, MetaMorph, µManager	Wave generator, data recorder, auto zero, trigger I/O, MATLAB, MetaMorph, µManager		
Controller dimensions	160 mm × 96 mm × 33 mm	160 mm × 96 mm × 33 mm		

All specifications based on room temperature (22 °C ±3 °C).

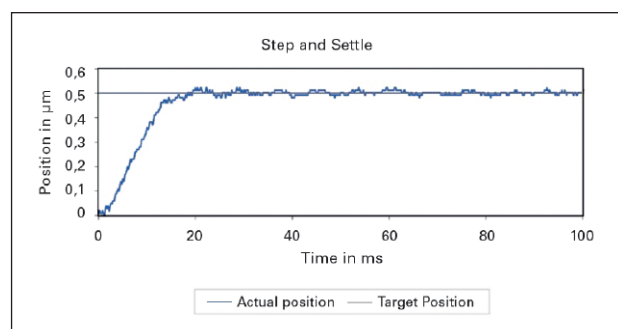

20 ms settling time with 150 g objective (PD72Z4CAQ system, measured with laser interferometer)

PD72Z1x PIFOC Objective Scanning System 100 μm

High-Dynamics Piezo Drive for Sub-Nanometer Resolution



- Complete system with digital controller, software and QuickLock thread insert
- USB, RS-232, analog interfaces
- Travel range 100 μm
- Scans and positions objectives with sub-nm resolution
- Zero-play, high-precision flexure guide system
- Direct metrology with capacitive sensors
- Compatible with μManager, MetaMorph and MATLAB
- Adaptation of all control parameters on the fly

PD72Z1xAQ, dimensions in mm. P-721.xxQ: Suitable PIFOC QuickLock thread adapters.

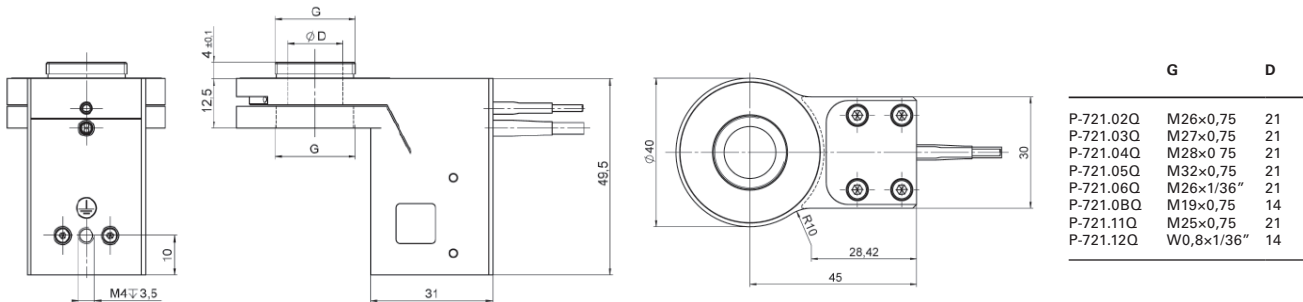

PD72Z1xAA, dimensions in mm. P-721.xxA: Suitable PIFOC QuickLock thread adapters.

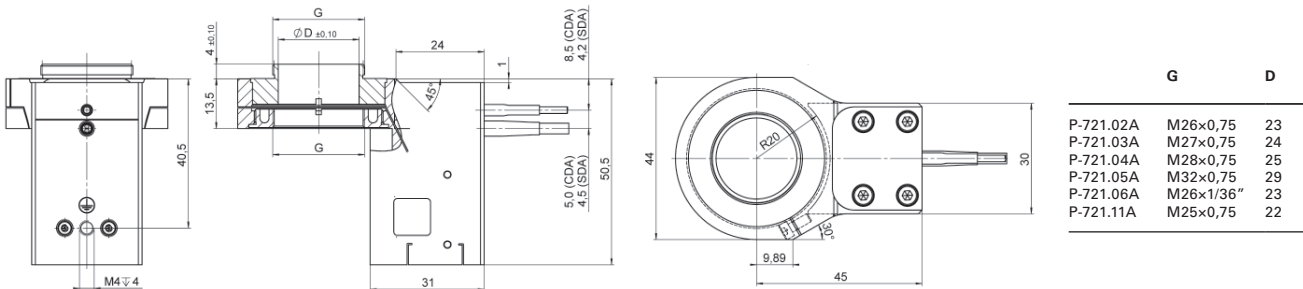

Applications

- Microscopy
- Confocal microscopy
- 3D-Imaging
- Screening
- Autofocus systems
- Surface analysis
- Wafer inspection

- >> Capacitive Sensors
- >> Direct Metrology
- >> Extensive Software Package

Technology Glossary page 240

	PD72Z1SAA / PD72Z1SAQ	PD72Z1CAA / PD72Z1CAQ	Units	Tolerance
Active axes	Z	Z		
Motion and positioning				
Integrated sensor	SGS	Capacitive		
Closed-loop travel	100	100	µm	
Closed-loop resolution	5	1	nm	typ.
Linearity error, closed-loop	0.2	0.06	%	typ.
Repeatability	±10	±5	nm	typ.
Runout θ_x, θ_y	13	13	µrad	typ.
Crosstalk in X, Y	100	100	nm	typ.
Settling time (0.5 µm step with 5 % accuracy, 150 g)	10	10	ms	typ.
Mechanical properties				
Stiffness in motion direction	0.3	0.3	N/µm	±20 %
Resonant frequency, no load	580	580	Hz	±20 %
Resonant frequency at 120 g	235	235	Hz	±20 %
Resonant frequency at 200 g	180	180	Hz	±20 %
Push / pull force capacity in motion direction	100 / 20	100 / 20	N	max.
Drive properties				
Piezo ceramic	PICMA® P-885	PICMA® P-885		
Miscellaneous				
Operating temperature range	10 to 50	10 to 50	°C	
Material	Aluminum	Aluminum		
Mass	0.22	0.24	kg	±5 %
Cable length	1	1	m	
Piezo controller				
	E-709 digital servo (included in delivery)	E-709 digital servo (included in delivery)		
Communication interfaces	USB, RS-232, SPI	USB, RS-232, SPI		
I/O connector	HD Sub-D 26-pin 1 analog input 0 to 10 V 1 sensor monitor 0 to 10 V 1 digital input (LVTTTL, programmable) 1 analog output 5 digital outputs (LVTTTL, 3 × predefined, 2 × programmable)	HD Sub-D 26-pin 1 analog input 0 to 10 V 1 sensor monitor 0 to 10 V 1 digital input (LVTTTL, programmable) 1 analog output 5 digital outputs (LVTTTL, 3 × predefined, 2 × programmable)		
Command set	PI General Command Set (GCS)	PI General Command Set (GCS)		
User software	PIMikroMove	PIMikroMove		
Software drivers	LabVIEW drivers, shared libraries for Windows and Linux	LabVIEW drivers, shared libraries for Windows and Linux		
Supported functionality	Wave generator, data recorder, auto zero, trigger I/O, MATLAB, MetaMorph, µManager	Wave generator, data recorder, auto zero, trigger I/O, MATLAB, MetaMorph, µManager		
Controller dimensions	160 mm × 96 mm × 33 mm	160 mm × 96 mm × 33 mm		

All specifications based on room temperature (22 °C ±3 °C).

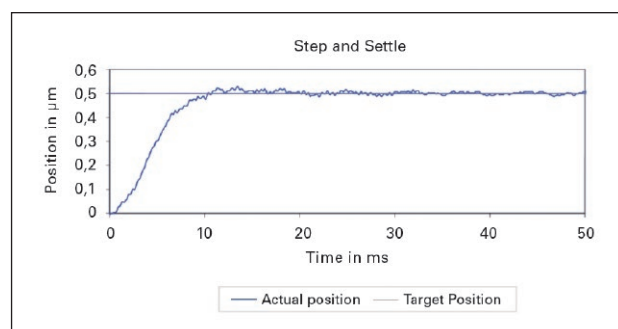

10 ms settling time with 150 g objective (PD72Z1CAQ system).

P-725 PIFOC

Objective Scanner with Long Travel Range

High-precision Positioner / Scanner for Microscope Objectives

- Travel ranges to 460 μm
- Significantly faster response and higher lifetime than motorized drives
- Fine positioning of objectives with sub-nm resolution
- Direct metrology with capacitive sensors: Highest linearity
- Zero-play, high-precision flexure guide system for better focus stability
- Compatible with MetaMorph imaging software
- Outstanding lifetime due to PICMA[®] piezo actuators
- QuickLock thread adapter for easy attachment
- Clear aperture up to $\varnothing 29 \text{ mm}$



P-725.xCD/.xCL, dimensions in mm (please order adapter separately).

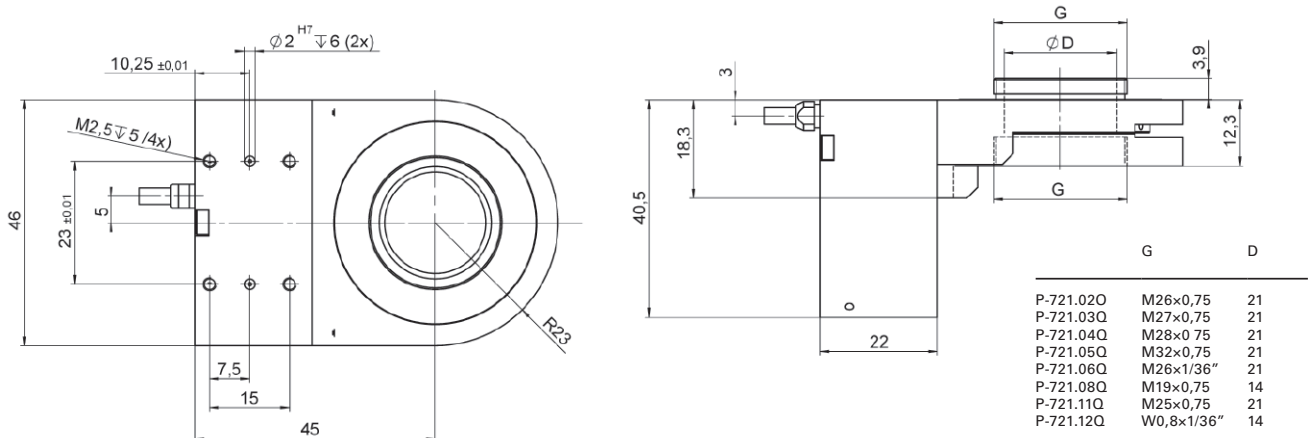

Applications

- Super-resolution microscopy
- Lightsheet microscopy
- Confocal microscopy
- 3D-Imaging
- Screening
- Interferometry
- Metrology
- Autofocus systems
- Biotechnology
- Semiconductor testing

- >> Capacitive Sensors
- >> Direct Metrology
- >> Flexure Guiding System
- >> PICMA[®] Multilayer Piezo Actuators

Technology Glossary page 240

	P-725.1CL P-725.1CD P-725.1CA	P-725.2CL P-725.2CD P-725.2CA	P-725.4CL P-725.4CD P-725.4CA	P-725.x0L open-loop version	Units	Tolerance
Active axes	Z	Z	Z	Z		
Motion and positioning						
Integrated sensor	Capacitive	Capacitive	Capacitive	–		
Travel range at –20 to +120 V, open loop	150	330	460	as P-725.xCL	µm	+20 % / –0 %
Closed-loop travel range	100	250	400	–	µm	
Open-loop resolution	0.3	0.4	0.5	as P-725.xCL	nm	typ.
Closed-loop resolution	0.65	0.75	1.25	–	nm	typ.
Linearity, closed-loop	0.03	0.03	0.03	–	%	typ.
Repeatability	±5	±5	±5	–	nm	typ.
Tilt θX	1	6	10	as P-725.xCL	µrad	typ.
Tilt θY	20	45	45	as P-725.xCL	µrad	typ.
Crosstalk in X	20	20	60	as P-725.xCL	nm	typ.
Crosstalk in Y	20	40	60	as P-725.xCL	nm	typ.
Mechanical properties						
Stiffness in motion direction	0.23	0.17	0.12	as P-725.xCL	N/µm	±20 %
Resonant frequency, no load	470	330	230	as P-725.xCL	Hz	±20 %
Resonant frequency under load, 150 g	185	140	120	as P-725.xCL	Hz	±20 %
Compressive / tensile stress capacity in motion direction	100 / 20	100 / 20	100 / 20	as P-725.xCL	N	max.
Drive properties						
Ceramic type	PICMA® P-885	PICMA® P-885	PICMA® P-885	as P-725.xCL		
Electrical capacitance	4.2	6.2	6.2	as P-725.xCL	µF	±20 %
Miscellaneous						
Operating temperature range	–20 to 80	–20 to 80	–20 to 80	–20 to 80	°C	
Material	Aluminum	Aluminum	Aluminum	Aluminum		
Objective diameter	39	39	39	39	mm	max.
Mass	0.215	0.23	0.23	as P-725.xCL	kg	±5 %
Sensor / voltage connection	CL version: LEMO Other: Sub-D 7W2 (m)	CL version: LEMO Other: Sub-D 7W2 (m)	CL version: LEMO Other: Sub-D 7W2 (m)	LEMO (no sensor)		
Recommended electronics	E-505, E-610, E-621, E-625, E-665, E-709, E-754	E-505, E-610, E-621, E-625, E-665, E-709, E-754	E-505, E-610, E-621, E-625, E-665, E-709, E-754	E-505, E-610, E-621, E-625, E-665, E-709, E-754		

All specifications based on room temperature (22 °C ±3 °C).

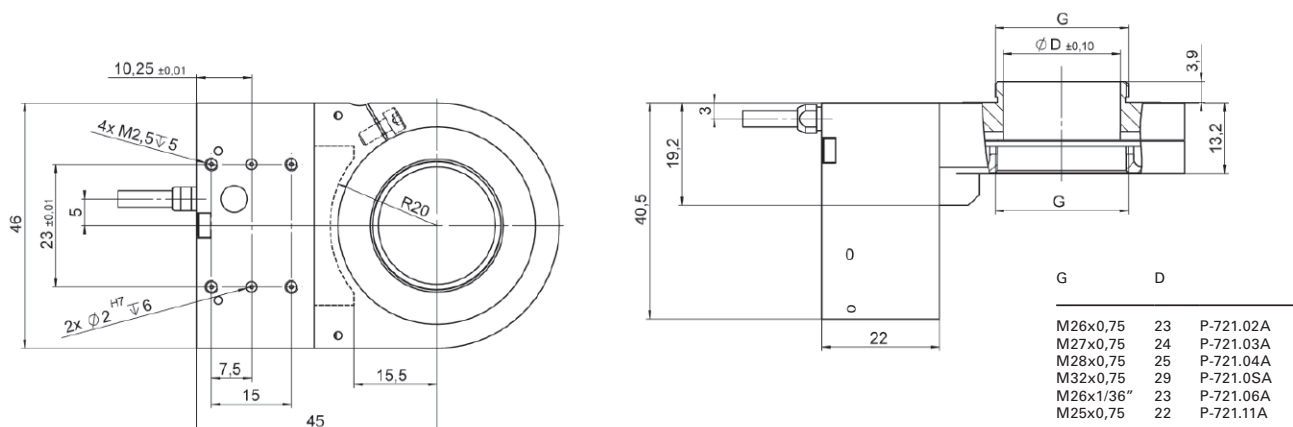

	P-725.CDD	P-725.SDD	Units	Tolerance
Active axes	Z	Z		
Motion and positioning				
Integrated sensor	Capacitive	SGS		
Open-loop travel, -20 to +120 V	18	18	µm	+20 % / -0 %
Closed-loop travel	18	18	µm	
Open-loop resolution	0.2	0.2	nm	typ.
Closed-loop resolution	0.2	0.2	nm	typ.
Closed-loop linearity error	0.04*	0.5	%	typ.
Repeatability	±1.5	±5	nm	typ.
Runout θX, θY	2	2	µrad	typ.
Crosstalk in X, Y	150	150	nm	typ.
Mechanical properties				
Stiffness in motion direction	1.5	1.5	N/µm	±20 %
Resonant frequency, no load	1180	1180	Hz	±20 %
Resonant frequency, under load, at 200 g	450	450	Hz	±20 %
Push / pull force capacity in motion direction	100 / 20	100 / 20	N	max.
Drive properties				
Ceramic type	PICMA® P-887	PICMA® P-887		
Electrical capacitance	3.1	3.1	µF	±20 %
Miscellaneous				
Operating temperature range	-20 to 80	-20 to 80	°C	
Material	Aluminum	Aluminum		
Mass	0.21	0.2	kg	±5 %
Cable length	1.5	1.5	m	±10 mm
Sensor / voltage connection	Sub-D 7W2 (m)	LEMO		
Recommended electronics	E-610, E-625, E-665, E-709.CHG, E-754	E-610, E-625, E-665, E-709.CHG, E-754		

* With E-753 digital controller. Non-linearity of direct drive stages measured with analog controllers is up to 0.1 % typ.
All specifications based on room temperature (22 °C ±3 °C).
Ask about custom designs!

P-726 PIFOC High-Load Objective Scanner

Highly Dynamic Scanning System with Long Travel Range for Heavy Objectives



P-726 with QuickLock thread adapter, dimensions in mm.

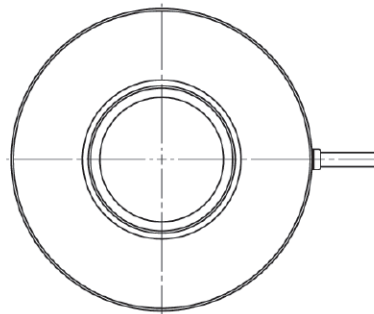
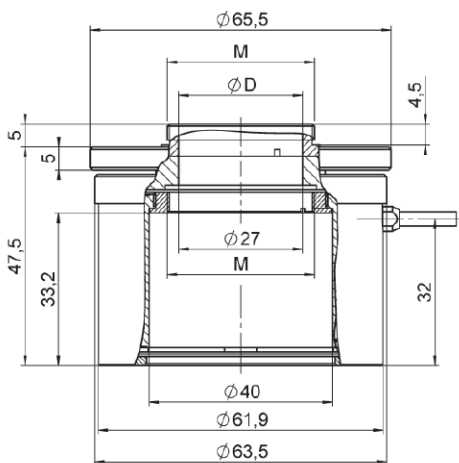

- Highly dynamic positioning and scanning for large objectives
- Resonant frequency 1120 Hz, 560 Hz with 210 g objective mass
- Typ. settling time of about 6 ms
- Travel range 100 μm
- Direct-metrology capacitive sensors for best linearity, stability and control dynamics
- Resolution 0.3 nm
- Zero-play, high-precision flexure guide system for better focus stability

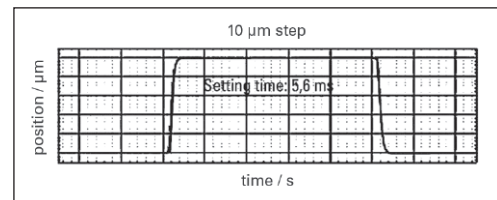

Settling behavior of the P-726 under load.

Quicklock	M	D
P-726.04	M28×0,75	23
P-726.05	M32×0,75	27
P-726.06	M26×1/36"	21
P-726.11	M25×0,75	21
P-726.12	W0,8×1/36"	16

Applications

- Super-resolution microscopy
- Lightsheet microscopy
- Confocal microscopy
- 3D-Imaging
- Screening
- Interferometry
- Metrology
- Autofocus systems
- Biotechnology
- Semiconductor testing

- >> Capacitive Sensors
- >> Direct Metrology
- >> Flexure Guiding System
- >> PICMA® Multilayer Piezo Actuators

Technology Glossary page 240

	P-726.1CD	Tolerance
Active axes	Z	
Motion and positioning		
Integrated sensor	Capacitive, direct metrology	
Closed-loop travel range	100 μm	
Closed-loop resolution	0.4 nm	typ.
Open-loop resolution	0.3 nm	typ.
Linearity error, closed loop	0.02 %	typ.
Repeatability	± 3 nm	typ.
Tilt θ_X, θ_Y	± 5 μrad	typ.
Crosstalk in X,Y	50 nm	typ.
Mechanical properties		
Stiffness in motion direction	3.4 N/ μm	± 20 %
Resonant frequency, no load	1120 Hz	± 20 %
Resonant frequency under load	560 Hz (210 g)	± 20 %
Resonant frequency under load	480 Hz (310 g)	± 20 %
Compressive / tensile stress capacity in motion direction	100 / 50 N	max.
Load capacity	20 N	max.
Drive properties		
Piezo ceramic type	PICMA® P-885	
Electrical capacitance	6 μF	± 20 %
Miscellaneous		
Operating temperature range	-20 to 80 °C	
Material	Aluminum, steel	
Objective thread	M32	max.
Mass	575 g	± 5 %
Cable length	1.5 m	± 10 mm
Sensor / voltage connection	Sub-D 7W2 (m)	
Recommended electronics	E-505, E-621, E-625, E-665, E-709, E-754	

All specifications based on room temperature (22 °C \pm 3 °C).
Ask about custom designs!

Microscope turret



Exploded view of the P-726 QuickLock adapter with P-726 PIFOC (mounting tools included in the scope of delivery).

P-721 PIFOC Piezo Flexure Objective Scanner

Fast Nanopositioner and Scanner for Microscope Objectives

- Scans and positions objectives with sub-nm resolution
- Travel ranges to 140 µm, millisecond settling time
- Significantly faster response and higher lifetime than motorized drives
- Parallel precision flexure guiding for better focus stability
- Direct metrology with capacitive sensors for highest linearity
- Cost-efficient version with SGS sensors
- Compatible with MetaMorph imaging software
- Outstanding lifetime due to PICMA® piezo actuators
- QuickLock thread adapter for easy attachment
- Clear aperture up to Ø 29 mm



P-721.xxQ, .SL2, dimensions in mm (adapter to be ordered separately).

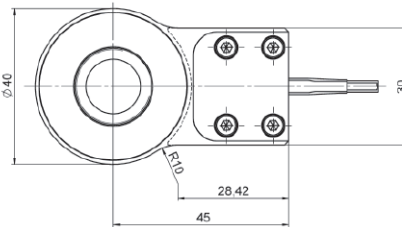
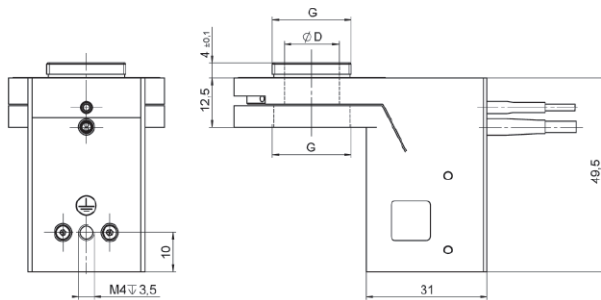

	G	D
P-721.02Q	M26×0,75	21
P-721.03Q	M27×0,75	21
P-721.04Q	M28×0,75	21
P-721.05Q	M32×0,75	21
P-721.06Q	M26×1/36"	21
P-721.08Q	M19×0,75	14
P-721.11Q	M25×0,75	21
P-721.12Q	W0,8×1/36"	14

P-721.CDA, .SDA, dimensions in mm (adapter to be ordered separately).

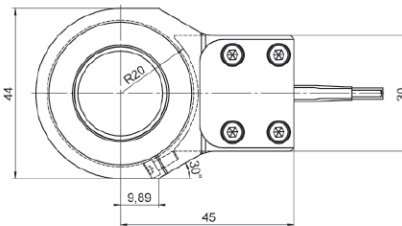
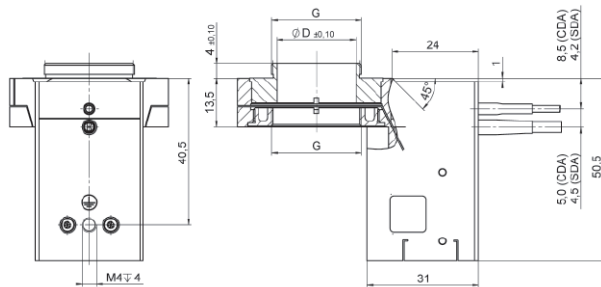

	G	D
P-721.02A	M26×0,75	23
P-721.03A	M27×0,75	24
P-721.04A	M28×0,75	25
P-721.05A	M32×0,75	29
P-721.06A	M26×1/36"	23
P-721.11A	M25×0,75	22

Applications

- Super-resolution microscopy
- Lightsheet microscopy
- Confocal microscopy
- 3D-Imaging
- Screening
- Interferometry
- Metrology
- Autofocus systems
- Biotechnology
- Semiconductor testing

- >> Capacitive Sensors
- >> Direct Metrology
- >> Flexure Guiding System
- >> PICMA® Multilayer Piezo Actuators

Technology Glossary page 240

	P-721.CLQ	P-721.CDQ P-721.CDA	P-721.SL2 P-721.SDA	P-721.OLQ	Units	Tolerance
Active axes	Z	Z	Z	Z		
Motion and positioning						
Integrated sensor	Capacitive	Capacitive	SGS	–		
Open-loop travel, –20 to +120 V	140	140	140	140	µm	+20 % / -0 %
Closed-loop travel	100	100	100	–	µm	
Open-loop resolution	0.5	0.5	0.5	0.5	nm	typ.
Closed-loop resolution	0.7	0.7	5	–	nm	typ.
Closed-loop linearity error	0.03	0.03	0.2	–	%	typ.
Repeatability	±5	±5	±10	–	nm	typ.
Runout θX, θY	13	13	13	13	µrad	typ.
Crosstalk X, Y	100	100	100	100	nm	typ.
Mechanical properties						
Stiffness in motion direction	0.3	0.3	0.3	0.3	N/µm	±20 %
Unloaded resonant frequency	580	580	580	550	Hz	±20 %
Resonant frequency at 120 g	235	235	235	235	Hz	±20 %
Resonant frequency at 200 g	180	180	180	180	Hz	±20 %
Push / pull force capacity in motion direction	100 / 20	100 / 20	100 / 20	100 / 20	N	max.
Drive properties						
Ceramic type	PICMA® P-885	PICMA® P-885	PICMA® P-885	PICMA® P-885		
Electrical capacitance	3.1	3.1	3.1	3.1	µF	±20 %
Miscellaneous						
Operating temperature range	–20 to 80	–20 to 80	–20 to 80	–20 to 80	°C	
Material	Aluminum	Aluminum	Aluminum	Aluminum		
Mass	0.24	0.24	0.22	0.22	kg	±5 %
Objective diameter	39	39	39	39	mm	max.
Cable length	1	1	1	1	m	±10 mm
Sensor / voltage connection	LEMO	Sub-D 7W2 (m)	LEMO / Sub-D 9 (m)	LEMO (no sensor)		
Recommended electronics	E-505, E-610, E-621, E-625, E-665, E-709, E-754	E-505, E-610, E-621, E-625, E-665, E-709, E 754	E-505, E-610, E-621, E-625, E-665, E-709, E 754	E-505, E-610, E-621, E-625, E-665, E-709, E 754		

* The resolution of PI piezo nanopositioners is not limited by friction or stiction.
Value given is noise equivalent motion with E-503 amplifier.
All specifications based on room temperature (22 °C ±3 °C).
Ask about custom designs!

P-736 Plnano[®] Z Microscope Scanner

Cost-efficient, low-profile



P-736, dimensions in mm.

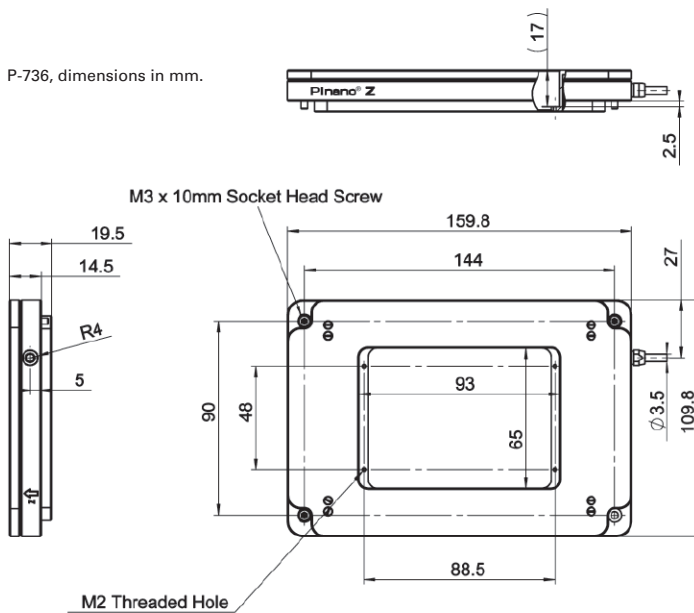

- Step-and-settle to 5 ms
- Low profile of 20 mm for easy integration
- Travel range 100 μm or 200 μm
- Clear aperture 93 mm \times 65 mm
- E-709 digital servo piezo controller included
- USB, RS-232, analog interfaces
- Compatible with MetaMorph imaging software

Applications

- Super-resolution microscopy
- Lightsheet microscopy
- Confocal microscopy
- 3D-Imaging
- Screening
- Interferometry
- Metrology
- Autofocus systems
- Biotechnology
- Semiconductor testing

- >> Extensive Software Package
- >> Flexure Guiding System
- >> PICMA[®] Multilayer Piezo Actuators

Technology Glossary page 240

	P-736.ZR1S	P-736.ZR2S	Unit	Tolerance
Active axes	Z	Z		
Motion and positioning				
Integrated sensor	Piezoresistive	Piezoresistive		
Closed-loop travel	100	200	µm	
Open-loop resolution	0.2	0.4	nm	typ.
Closed-loop resolution	0.4	0.7	nm	typ.
Mechanical properties				
Settling time (10 % step width)	5	7	ms	
Load capacity	500	500	g	max.
Drive properties				
Piezo ceramic	PICMA® P-885	PICMA® P-885		
Miscellaneous				
Operating temperature range	15 to 40	15 to 40	°C	
Material	Aluminum	Aluminum		
Mass	550	550	g	±5 %
Cable length	1.5	1.5	m	±10 mm
Piezo controller				
	E-709 digital servo (included in delivery)	E-709 digital servo (included in delivery)		
Communication interfaces	USB, RS-232, SPI	USB, RS-232, SPI		
I/O connector	HD Sub-D 26-pin 1 × analog input 0 to 10 V 1 × sensor monitor 0 to 10 V 1 × digital input (LVTTTL, programmable) 1 × analog output 5 × digital outputs (LVTTTL, 3 × predefined, 2 × programmable)	HD Sub-D 26-pin 1 × analog input 0 to 10 V 1 × sensor monitor 0 to 10 V 1 × digital input (LVTTTL, programmable) 1 × analog output 5 × digital outputs (LVTTTL, 3 × predefined, 2 × programmable)		
Command set	PI General Command Set (GCS)	PI General Command Set (GCS)		
User software	PIMikroMove	PIMikroMove		
Software drivers	LabVIEW driver, dynamic libraries for Windows and Linux	LabVIEW driver, dynamic libraries for Windows and Linux		
Supported functionality	Wave generator, data recorder, auto zero, trigger I/O, MATLAB, MetaMorph, µManager	Wave generator, data recorder, auto zero, trigger I/O, MATLAB, MetaMorph, µManager		
Controller dimensions	160 mm × 96 mm × 33 mm	160 mm × 96 mm × 33 mm		

All specifications based on room temperature (22 °C ±3 °C).

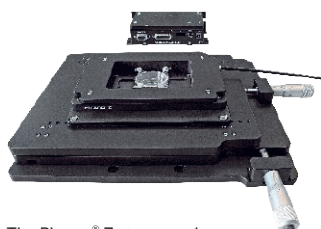

The Plnano® Z stage can be combined with the M-545 XY 25 × 25 mm microscope stage

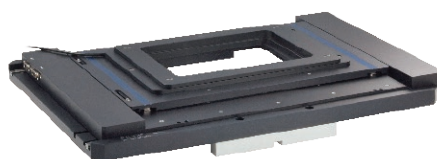

Custom versions are feasible. The example above shows a P-736 version with a particularly large aperture mounted on a XY stage driven by PLine® piezomotors.

P-737 PIFOC Specimen-Focusing Z Stage

Low-Profile with Large Aperture



- Travel ranges to 500 μm
- Clear aperture 128.5 mm \times 86.5 mm to accommodate microtiter plates
- Low profile 20 mm
- Compatible with MetaMorph imaging software

P-737, dimensions in mm.

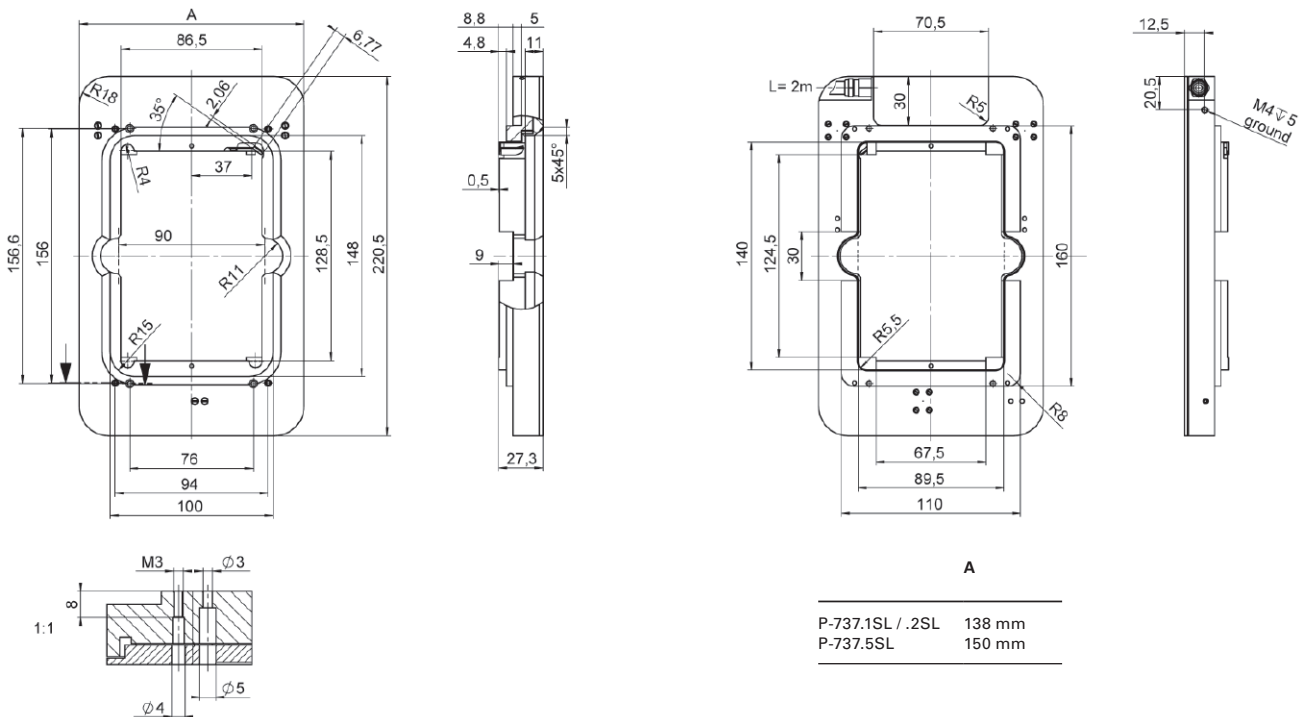

Applications

- Super-resolution microscopy
- Lightsheet microscopy
- Confocal microscopy
- 3D-Imaging
- Screening
- Interferometry
- Metrology
- Autofocus systems
- Biotechnology
- Semiconductor testing

- >> Flexure Guiding System
- >> PICMA® Multilayer Piezo Actuators

Technology Glossary page 240

	P-737.1SL	P-737.2SL	P-737.5SL	Unit	Tolerance
Active axes	Z	Z	Z		
Motion and positioning					
Integrated sensor	SGS	SGS	SGS		
Open-loop travel, -20 to 120 V	150	280	550	µm	+20 % / -0 %
Closed-loop travel	100	250	500	µm	
Open-loop resolution	0.8	1	1.6	nm	typ.
Closed-loop resolution	2.5	4	5	nm	typ.
Closed-loop linearity error	0.2	0.5	0.8	%	typ.
Repeatability	6	12	15	nm	typ.
Angular runout θ_x	±36	±36	±36	µrad	typ.
Angular runout θ_y	±36	±100	±100	µrad	typ.
Mechanical properties					
Unloaded resonant frequency	270	210	122	Hz	±20 %
Resonant frequency at 100 g	230	180	115	Hz	±20 %
Resonant frequency at 200 g	210	155	100	Hz	±20 %
Push / pull force capacity in motion direction	50 / 20	50 / 20	50 / 20	N	max.
Drive properties					
Piezo ceramic	PICMA® P-885	PICMA® P-885	PICMA® P-885		
Electrical capacitance	6.3	9.3	13.8	µF	±20 %
Miscellaneous					
Operating temperature range	-20 to 80	-20 to 80	-20 to 80	°C	
Material	Aluminum	Aluminum	Aluminum		
Dimensions	220,5 mm × 138 mm × 27,3 mm	220,5 mm × 138 mm × 27,3 mm	220,5 mm × 150 mm × 27,3 mm		
Mass	0.7	0.7	0.85	kg	±5 %
Cable length	2	2	2	m	±10 mm
Sensor / voltage connection	LEMO	LEMO	LEMO		
Recommended electronics	E-625, E-665, E-709	E-625, E-665, E-709	E-625, E-665, E-709		
System properties					
System configuration	E-500 system with E-503 amplifier (6 W) E-509 servo module	E-500 system with E-503 amplifier (6 W) E-509 servo module	E-665.SR controller / driver (12 W)		
Closed-loop amplifier bandwidth, small signal	60	30	15	Hz	typ.
Settling time (10 % step width)	24	30	50	ms	typ.

All specifications based on room temperature (22 °C ±3 °C).

Versions with directly measuring, high-resolution capacitive sensors and custom versions on request!

P-545.3D8S Plnano[®] Trak Piezo Tracking System

Fast XY(Z) stage for high dynamics microscopy



- Fast response time <5 ms with subnanometer resolution: Ideal for tracking
- E-727 USB controller and software included
- Travel ranges to 70 μm × 70 μm × 50 μm
- Low profile for easy integration: 20 mm
- Recessed sample holders, freely revolving nosepiece
- Extensive optional accessories
- Cost-effective design

P-545.xx8S, dimensions in mm.

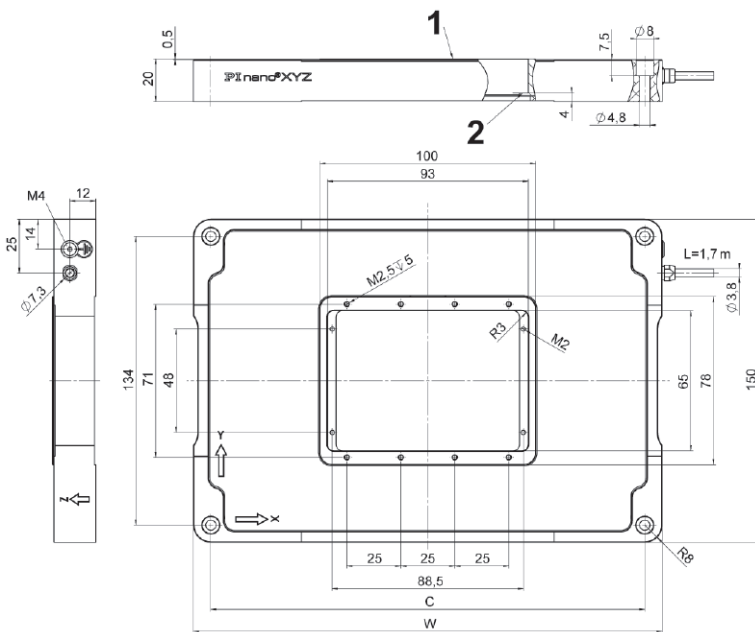

- 1: Upper mounting surface of the motion platform
- 2: Lower mounting surface of the motion platform

Model	W	C
P-545.3x8S	217	201
P-545.2x8S	182	166

Applications

- Tracking
- High-resolution microscopy
- Inverted microscopy
- Screening
- Confocal microscopy
- Biotechnology

- >> Extensive Software Package
- >> Flexure Guiding System
- >> PICMA[®] Multilayer Piezo Actuators

Technology Glossary page 240

	P-545.3D8S	Unit	Tolerance
Active axes	X, Y, Z		
Motion and positioning			
Integrated sensor	Piezoresistive		
Closed-loop travel range	70 × 70 × 50	μm	
Closed-loop resolution*	<1	nm	typ.
Mechanical properties			
Resonant frequency, no load	1 (X, Y), 0.8 (Z)	kHz	
Push/pull force capacity	100 / 30	N	max.
Recommended load**	0.5	kg	max.
Drive properties			
Piezo ceramic	PICMA®		
Electrical capacitance	12 (X, Y), 24 (Z)	μF	±20 %
Miscellaneous			
Operating temperature range	15 to 40	°C	
Material	Aluminum		
Mass	1.2	kg	±5 %
Cable length	1.7	m	+10 cm
Piezo controller			
	E-727.3RDA (included in scope of delivery)		
Communication interfaces	Ethernet, USB, RS-232, serial SPI high-speed interface		
Analog input / Analog output	Sub-D (15-pin) Input via 18-bit A/D converter Output via 20-bit D/A converter		
Command set	PI General Command Set (GCS)		
User software	PIMikroMove		
Software drivers	LabVIEW drivers, shared libraries for Windows and Linux		
Supported functions	Wave generator, data recorder, drift compensation, macros		
Software drivers	LabVIEW drivers, shared libraries for Windows and Linux		
Supported functions	Wave generator, data recorder, drift compensation, macros		

* With flexure guides, the resolution is not limited by friction. Value given is noise equivalent motion measured with interferometer.

** For dynamic operation. Higher dynamics are possible with a reduced load.

All specifications based on room temperature (22 °C ±3 °C).

Ask about custom designs!

Accessories: P-545.PD3, Petri dish holder,
dimensions in mm.

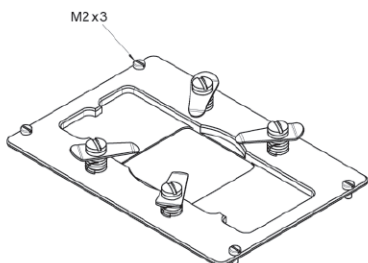
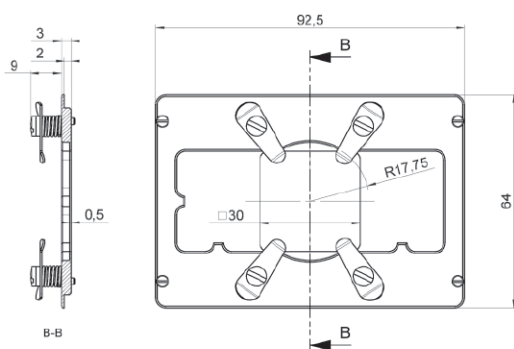

Accessories: P-545.SH3, microscope slide holder,
dimensions in mm.

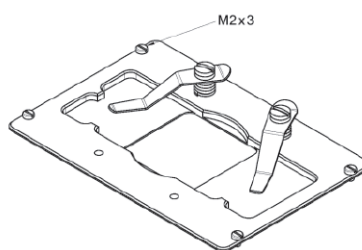
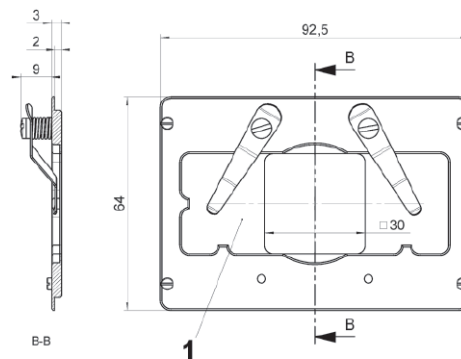

1: Recess for standard
microscope slides
(25 mm × 75 mm)

P-545.xR8S Plnano[®] XY(Z) Piezo System

Low-cost nanopositioning system for superresolution microscopy



- Inexpensive cost-optimized design due to piezoresistive sensors
- Travel ranges to 200 μm × 200 μm × 200 μm
- E-727 USB controller and software included
- Low profile for easy integration: 20 mm
- Clear aperture for 3 × 1" microscope slide, recessed sample holders
- Outstanding lifetime due to PICMA[®] piezo actuators
- Subnanometer resolution, fast response in the ms range

P-545.xx8S, dimensions in mm

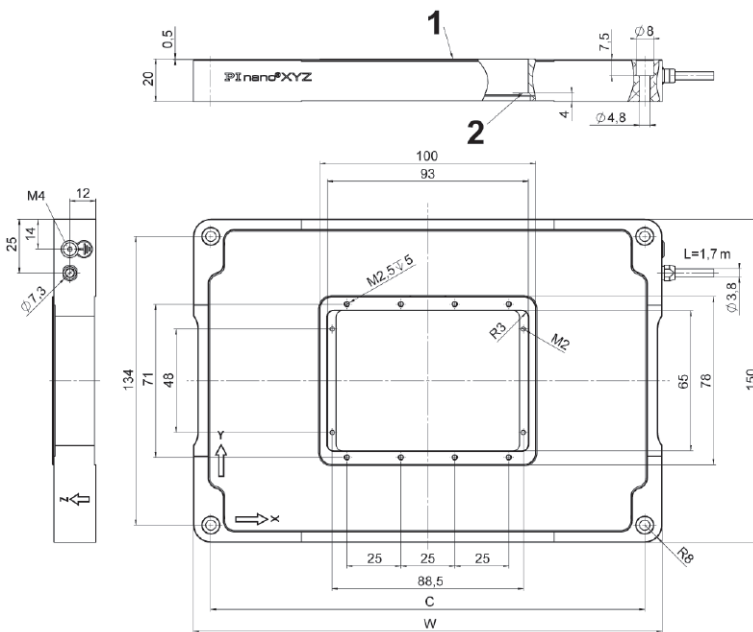

- 1: Upper mounting surface of the motion platform
- 2: Lower mounting surface of the motion platform

Model	W	C
P-545.3x8S	217	201
P-545.2x8S	182	166

Applications

- High-resolution microscopy
- Screening
- Confocal microscopy
- Biotechnology
- High reliability even with high ambient humidity

- >> Extensive Software Package
- >> Flexure Guiding System
- >> PICMA[®] Multilayer Piezo Actuators

Technology Glossary page 240

	P-545.2R8S	P-545.3R8S	Unit	Tolerance
Active axes	X,Y	X, Y, Z		
Motion and positioning				
Integrated sensor	Piezoresistive	Piezoresistive		
Closed-loop travel	200 × 200	200 × 200 × 200	μm	
Closed-loop resolution*	1	1	nm	typ.
Mechanical properties				
Push / pull force capacity	50 / 30	50 / 30	N	max.
Recommended load**	0.5	0.5	kg	max.
Drive properties				
Piezo ceramic	PICMA® P-885	PICMA® P-885		
Electrical capacitance	6 (X, Y)	6 (X, Y), 12 (Z)	μF	±20 %
Miscellaneous				
Operating temperature range	15 to 40	15 to 40	°C	
Material	Aluminum	Aluminum		
Mass	1	1.2	kg	±5 %
Cable length	1.7	1.7	m	+10 cm
Piezo controller				
	E-727.3RDA (included in scope of delivery)			
Communication interfaces	Ethernet, USB, RS-232, serial SPI high-speed interface			
Analog input / Analog output	Sub-D (15-pin) Input via 18-bit A/D converter Output via 20-bit D/A converter			
Command set	PI General Command Set (GCS)			
User software	PIMikroMove			
Software drivers	LabVIEW drivers, shared libraries for Windows and Linux			
Supported functions	Wave generator, data recorder, drift compensation, macros			

* With flexure guides, the resolution is not limited by friction. Value given is noise equivalent motion measured with interferometer.

** For dynamic operation. Higher dynamics are possible with a reduced load.

All specifications based on room temperature (22 °C ±3 °C).

Ask about custom designs!

Accessories: P-545.PD3, Petri dish holder,
dimensions in mm

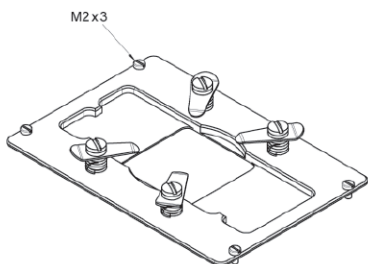
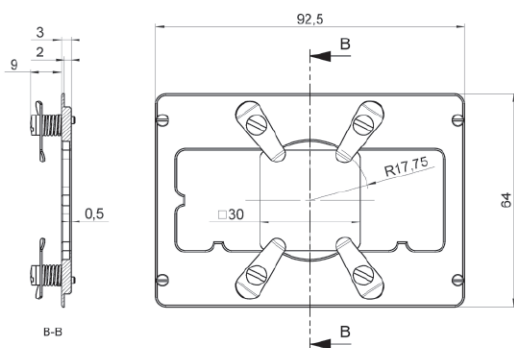

Accessories: P-545.SH3, microscope slide holder,
dimensions in mm

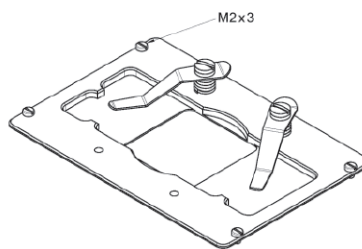
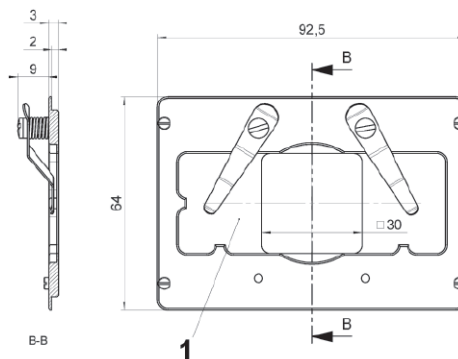

1: Recess for standard microscope slides (25 mm × 75 mm)

P-545.xC8S PInano[®] Cap XY(Z) Piezo System

Capacitive Positioning Measurement for Superresolution Microscopy



- Highest stability and repeatability
- Travel ranges to 200 $\mu\text{m} \times 200 \mu\text{m} \times 200 \mu\text{m}$
- E-727 USB controller and software included
- Subnanometer resolution
- Fast response in the ms range
- Low profile for easy integration: 20 mm
- Recessed sample holders, freely revolving nosepiece

P-545.xx8S, dimensions in mm.

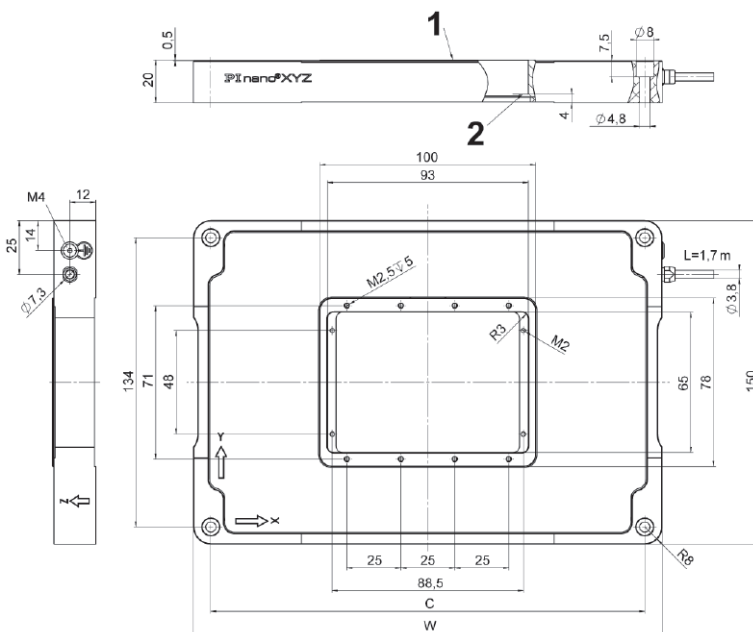

- 1: Upper mounting surface of the motion platform
 2: Lower mounting surface of the motion platform

Model	W	C
P-545.3x8S	217	201
P-545.2x8S	182	166

Applications

- Superresolution microscopy
- Screening
- Confocal microscopy
- Biotechnology
- High reliability even in environments with high ambient humidity

- >> Capacitive Sensors
- >> Direct Metrology
- >> Extensive Software Package
- >> Flexure Guiding System
- >> PICMA[®] Multilayer Piezo Actuators

Technology Glossary page 240

	P-545.2C8S	P-545.3C8S	Unit	Tolerance
Active axes	X,Y	X, Y, Z		
Motion and positioning				
Integrated sensor	Capacitive	Capacitive		
Closed-loop travel range	200 × 200	200 × 200 × 200	µm	
Closed-loop resolution*	<1	<1	nm	typ.
Mechanical properties				
Compressive/tensile stress capacity	50 / 30	50 / 30	N	max.
Recommended load**	0.5	0.5	kg	max.
Drive properties				
Piezo ceramic	PICMA® P-885	PICMA® P-885		
Electrical capacitance	6 (X, Y)	6 (X, Y), 12 (Z)	µF	±20 %
Miscellaneous				
Operating temperature range	15 to 40	15 to 40	°C	
Material	Aluminum	Aluminum		
Mass	1	1.2	kg	±5 %
Cable length	1.7	1.7	m	+10 cm
Piezo controller	E-727.3CDA (included in scope of delivery)			
Communication interfaces	Ethernet, USB, RS-232, serial SPI high-speed interface			
Analog input / Analog output	Sub-D (15-pin) Input via 18-bit A/D converter Output via 20-bit D/A converter			
Command set	PI General Command Set (GCS)			
User software	PIMikroMove			
Software drivers	LabVIEW drivers, shared libraries for Windows and Linux			
Supported functions	Function generator, data recorder, drift compensation, macros			

* With flexure guides, the resolution is not limited by friction. Value given is noise equivalent motion measured with interferometer.

** For dynamic operation. Higher dynamics are possible with a reduced load.

All specifications based on room temperature (22 °C ±3 °C).

Ask about custom designs!

Accessories: P-545.PD3, Petri dish holder,
dimensions in mm.

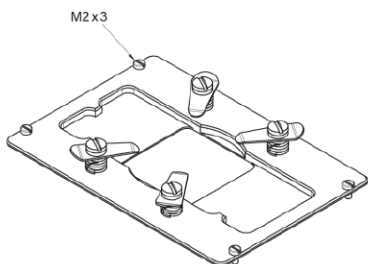
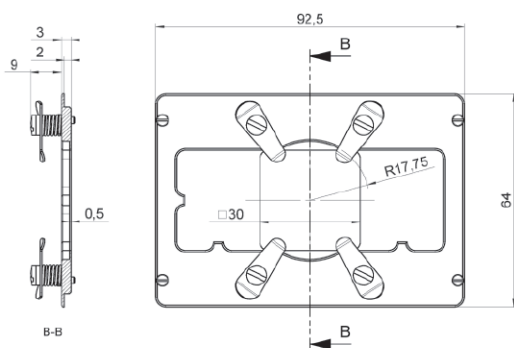

Accessories: P-545.SH3, microscope slide holder,
dimensions in mm.

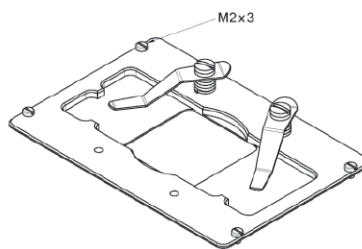
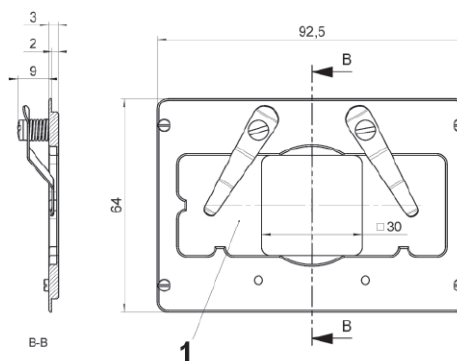

1: Recess for standard microscope slides (25 mm × 75 mm)

Tilting Mirrors



Tilting Mirrors	104
S-310 / S-316 Piezo Z / Tip / Tilt Scanner	106
S-325 Piezo Z / Tip / Tilt Platform	108
S-330 Piezo Tip / Tilt Platform	110
S-331 Fast Tip / Tilt Platform	112
S-335 Fast Tip / Tilt Platform	114
S-340 Piezo Tip / Tilt Platform	116

S-310 / S-316 Piezo Z / Tip / Tilt Scanner

High-Speed System with Clear Aperture



- 10 mm clear aperture
- Piezo tripod design
- Optical beam deflection to 2.4 mrad
- Piston movement up to 12 μm (phase shifter)
- Sub-ms response time
- Sub- μrad resolution
- Closed-loop versions for higher precision
- For optics, mirrors or other components
- Zero-play, high-precision flexure guide system
- Parallel kinematics for higher accuracy and dynamics

S-31x, dimensions in mm. The general tolerance according to DIN ISO 2768-f-H applies to all non-tolerated dimensions.

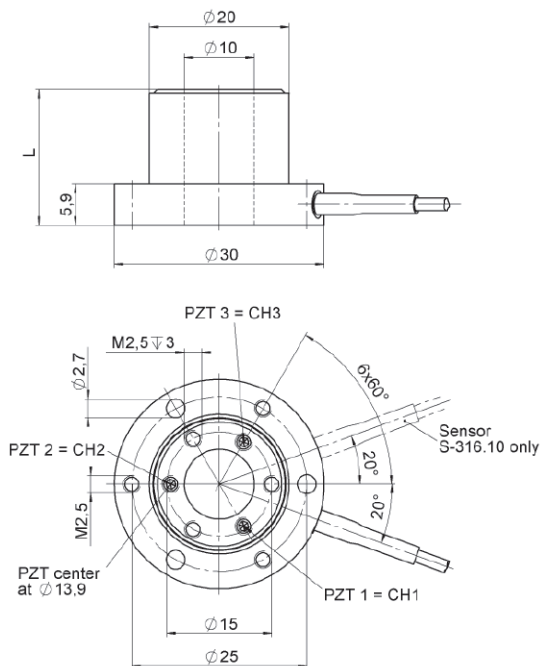

	L [mm]
S-310.10	19,5
S-311.10	19,5
S-314.10	28,5
S-315.10	28,5
S-316.10	28,5

S-315 cable configuration

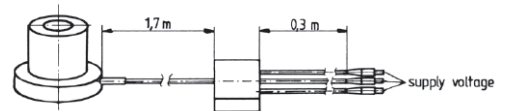

S-316 cable configuration

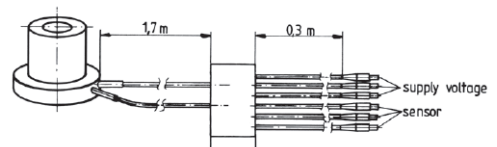

Applications

- Image processing / stabilization
- Laser scanning / beam steering
- Laser tuning
- Optical filters / switches
- Beam stabilization
- Interferometry

- >> Flexure Guiding Systems
- >> Parallel-Kinematic Piezo Stages
- >> PICMA® Multilayer Piezo Actuators

Technology Glossary page 240

	S-310.10	S-314.10	S-311.10	S-315.10	S-316.10 S-316.10H	Unit	Tolerance
Active axes	Z	Z	Z, θ_x, θ_y	Z, θ_x, θ_y	Z, θ_x, θ_y		
Motion and positioning							
Integrated sensor	–	–	–	–	SGS		
Open-loop travel in Z at 0 to 100 V	6 / –	12 / –	6 / –	12 / –	12 / 12	μm	+20 % / –0 %
Open-loop tip / tilt angle, 0 to 100 V	–	–	600	1200	1200	μrad	+20 % / –0 %
Closed-loop travel in Z	–	–	–	–	12	μm	
Closed-loop tilt angle	–	–	–	–	1200	μrad	
Open-loop resolution in Z	0.1	0.2	0.1	0.2	0.2	nm	typ.
Open-loop resolution in θ_x, θ_y	–	–	0.02	0.05	0.05	μrad	typ.
Closed-loop resolution in Z	–	–	–	–	0.4	nm	typ.
Closed-loop resolution in θ_x, θ_y	–	–	–	–	0.1	μrad	typ.
Linearity error	–	–	–	–	0.2	%	typ.
Mechanical properties							
Stiffness in Z	20	10	20	10	10	N/ μm	$\pm 20\%$
Resonant frequency, no load, in Z	9.5	5.5	9.5	5.5	5.5	kHz	$\pm 20\%$
Resonant frequency, under load (with 15 mm x 4 mm glass mirror)	6.5	4.4	6.5	4.1	4.1	kHz	$\pm 20\%$
Resonant frequency, under load (with 20 mm x 4 mm glass mirror)	6.1	4.2	6.1	3.4	3.4	kHz	$\pm 20\%$
Distance of pivot point to platform surface	–	–	5	5	5	mm	$\pm 0.5\text{ mm}$
Platform moment of inertia	–	–	150	150	150	g x mm ²	$\pm 20\%$
Drive properties							
Ceramic type	PICMA [®] P-882	PICMA [®] P-882	PICMA [®] P-882	PICMA [®] P-882	PICMA [®] P-882		
Electrical capacitance	0.39	0.93	0.39 (0.13 per axis)	0.93 (0.31 per axis)	0.93 (0.31 per axis)	μF	$\pm 20\%$
Miscellaneous							
Operating temperature range	–20 to 80	–20 to 80	–20 to 80	–20 to 80	–20 to 80	°C	
Material	Steel	Steel	Steel	Steel	Steel		
Mass	0.053	0.055	0.045	0.055	0.055	kg	$\pm 5\%$
Cable length	2	2	2	2	2	m	+100 mm / –0 mm
Sensor connection	–	–	–	–	S-316.10: LEMO S-316.10H: Sub-D 37 (m)		
Voltage connection	LEMO	LEMO	LEMO	LEMO	S-316.10: LEMO S-316.10H: Sub-D 37 (m)		
Recommended electronics	E-505, E-610, E-625, E-727	E-505, E-610, E-625, E-727	E-505, E-610, E-625, E-727	E-505, E-610, E-625, E-727	E-505, E-610, E-625, E-727		

Resolution of PI piezo scanners is not limited by friction or stiction. Value given is noise equivalent motion with E 503 amplifier.
 Mechanical tilt, optical beam deflection is twice as large. For maximum tilt range, all three piezo actuators must be biased at 50 V.
 Due to the parallel-kinematics design, linear travel and tilt angle are interdependent. The values quoted here refer to pure linear / pure angular motion.
 All specifications based on room temperature (22 °C \pm 3 °C).

Tilting Mirrors

S-325 Piezo Z / Tip / Tilt Platform

High-Speed Tripod System for Mirrors and Optics



S-325, dimensions in mm.

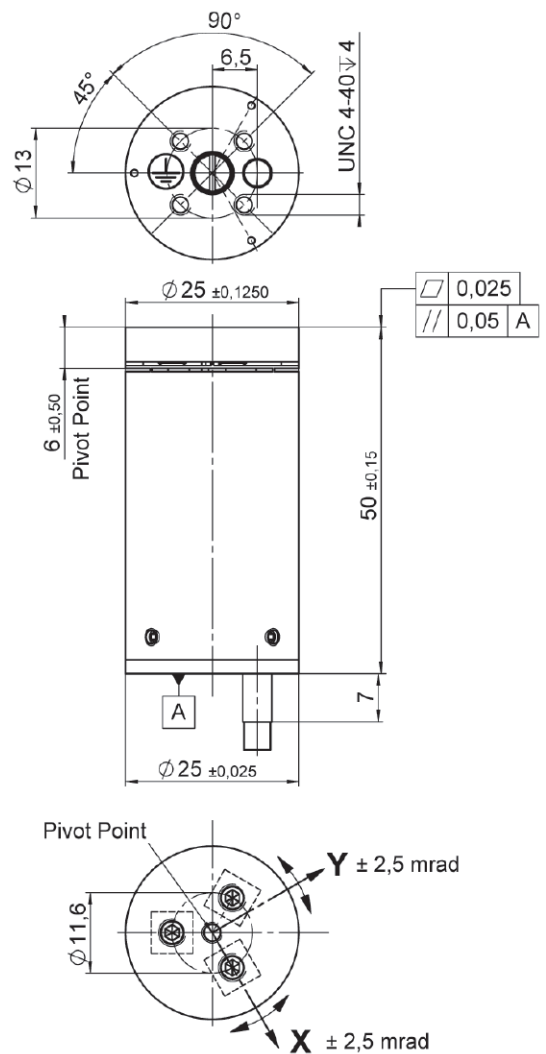

- Optical beam deflection to 10 mrad
- Resolution to 50 nrad
- Piston movement up to 30 μm (for path length adjustment)
- Compact tripod design
- Sub-ms response time
- Closed-loop versions for higher precision
- For optics up to \varnothing 25 mm (1")
- Zero-play, high-precision flexure guide system
- Parallel kinematics for higher accuracy and dynamics

Applications

- Image processing / stabilization
- Optical filters / switches
- Optical trapping
- Optics
- Laser scanning / beam steering
- Beam stabilization
- Laser tuning

- >> Flexure Guiding Systems
- >> Parallel-Kinematic Piezo Stages
- >> PICMA® Multilayer Piezo Actuators

Technology Glossary page 240

	S-325.30L	S-325.3SL	S-325.3SD	Unit	Tolerance
Active axes	Z, θ_x , θ_y	Z, θ_x , θ_y	Z, θ_x , θ_y		
Motion and positioning					
Integrated sensor	0	SGS	SGS		
Open-loop travel in Z at 0 to 100 V	30	30	30	μm	+20 % / -0 %
Open-loop tip / tilt angle, 0 to 100 V	5	5	5	mrad	+20 % / -0 %
Closed-loop travel in Z	-	30	30	μm	
Closed-loop tip / tilt angle in θ_x , θ_y	-	4	4	mrad	
Open-loop resolution in Z	0.5	0.5	0.5	nm	typ.
Open-loop resolution in θ_x , θ_y	0.05	0.05	0.05	μrad	typ.
Closed-loop resolution in Z	-	0.6	0.6	nm	typ.
Closed-loop resolution in θ_x , θ_y	-	0.1	0.1	μrad	typ.
Mechanical properties					
Unloaded resonant frequency in Z	2	2	2	kHz	± 20 %
Resonant frequency, under load (with 25 mm x 8 mm glass mirror)	1	1	1	kHz	± 20 %
Distance of pivot point to platform surface	6	6	6	mm	± 0.5 mm
Platform moment of inertia	515	515	515	$\text{g} \times \text{mm}^2$	± 20 %
Drive properties					
Ceramic type	PICMA® P-885	PICMA® P-885	PICMA® P-885		
Electrical capacitance	9.3	9.3	9.3	μF	± 20 %
Miscellaneous					
Operating temperature range	-20 to 80	-20 to 80	-20 to 80	$^{\circ}\text{C}$	
Material case	Aluminum	Aluminum	Aluminum		
Mass	0.065	0.065	0.065	kg	± 5 %
Cable length	2	2	1.5	m	± 10 mm
Sensor / voltage connection	LEMO	LEMO	Sub-D 25 (m)		
Recommended electronics	E-610, E-616, E-663, E-727	E-610, E-616, E-663, E-727	E-610, E-616, E-663, E-727		

For maximum tilt range, all three piezo actuators must be biased at 50 V. Due to the parallel-kinematics design linear travel and tilt angle are interdependent. The values quoted here refer to pure linear / pure angular motion. All specifications based on room temperature (22 °C \pm 3 °C).

S-325 cable configuration
(top: S-325.30L, bottom: S-325.3SL)

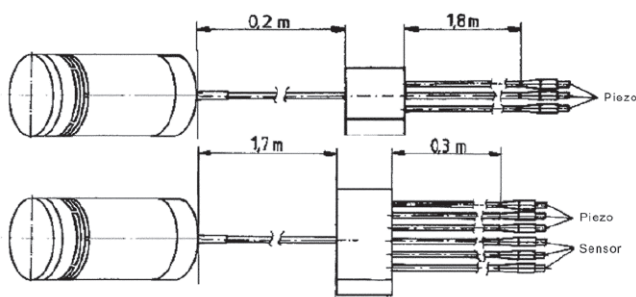

S-330 Piezo Tip / Tilt Platform

Highly Dynamic, with Large Deflection Angle for Mirrors and Optics



Precision class tip / tilt platform for applications with high demand on the dynamics

Two orthogonal tip / tilt axes with common center of rotation. Parallel kinematic design for identical performance characteristics of both axes. Flexure guides for friction-free motion and high stiffness. Direct drive.

Strain sensors for low linearity errors

Strain gauge sensors with low temperature sensitivity. Linearity error to 0.2 %.

PICMA high-performance drives

Piezoceramic actuators with all-ceramic insulation. Longer lifetime, insensitive to humidity and high operating temperatures.

Applications

- Image processing / stabilization
- Optical trapping
- Laser scanning / beam steering
- Laser tuning
- Optical filters / switches
- Optics
- Beam stabilization

- Resolution to 20 nrad
- Excellent position stability
- Optical beam deflection to 20 mrad (>1°)
- Parallel kinematics for higher accuracy and dynamics and full bridge strain gauge sensors
- Sub-ms response time
- For mirrors to Ø 50 mm

S-330.xSH, dimensions in mm.

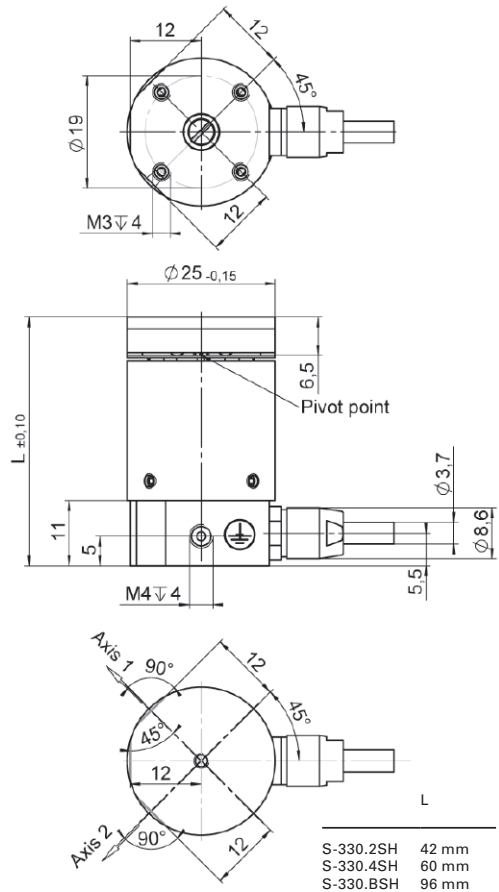

- >> Flexure Guiding Systems
- >> Parallel-Kinematic Piezo Stages
- >> PICMA® Multilayer Piezo Actuators

Technology Glossary page 240

	S-330.2SH / S-330.2SL	S-330.4SH / S-330.4SL	S-330.8SH / S-330.8SL	Unit	Tolerance
Active axes	θ_x, θ_y	θ_x, θ_y	θ_x, θ_y		
Motion and positioning					
Integrated sensor*	SGS	SGS	SGS		
Open-loop tip / tilt angle in θ_x, θ_y at -20 to 120 V	3.5	7	15	mrad	min.
Closed-loop tip / tilt angle in θ_x, θ_y	2	5	10	mrad	
Open-loop resolution in θ_x, θ_y	0.02	0.1	0.2	μ rad	typ.
Closed-loop resolution in θ_x, θ_y	0.05	0.25	0.5	μ rad	typ.
Linearity error in θ_x, θ_y	0.05 ** 0.2 ***	0.1 ** 0.2 ***	0.1 ** 0.2 ***	%	typ.
Repeatability in θ_x, θ_y 10 % tip / tilt angle	0.06 ** 0.15 ***	0.08 ** 0.5 ***	0.15 ** 1 ***	μ rad	typ.
Repeatability in θ_x, θ_y 100 % tip / tilt angle	0.6 ** 1.5 ***	0.8 ** 5 ***	1.5 ** 10 ***	μ rad	typ.
Mechanical properties					
Resonant frequency, no load, in θ_x, θ_y	2.4	2.0	1.0	kHz	± 20 %
Resonant frequency, under load, in θ_x, θ_y (with glass mirror, \varnothing 25 mm, thickness 8 mm)	1.6	1.5	1.0	kHz	± 20 %
Distance of pivot point to platform surface	6.5	6.5	6.5	mm	± 1 mm
Platform moment of inertia	1530	1530	1530	$g \times mm^2$	± 20 %
Drive properties					
Ceramic type	PICMA®	PICMA®	PICMA®		
Electrical capacitance	3 / axis	6 / axis	12.5 / axis	μ F	± 20 %
Miscellaneous					
ID chip functionality	S-330.2SH	S-330.4SH	S-330.8SH		
Operating temperature range	-20 to 80	-20 to 80	-20 to 80	$^{\circ}$ C	
Material housing	Steel	Steel	Steel		
Material platform	Invar	Invar	Invar		
Mass	0.2	0.38	0.7	kg	± 5 %
Cable length	2	2	2	m	+100 mm / -0 mm
Sensor / voltage connection	Sub-D 37 (m) (S-330.2SH), LEMO (S-330.2SL)	Sub-D 37 (m) (S-330.4SH), LEMO (S-330.4SL)	Sub-D 37 (m) (S-330.8SH), LEMO (S-330.8SL)		
Recommended electronics	E-503, E-505, E-663, E-727	E-503, E-505, E-663, E-727	E-503, E-505, E-663, E-727		

* Models without sensor are available on request.
 ** .xSH in conjunction with digital controllers
 *** .xSL in conjunction with E-5xx analog controller modules
 All specifications based on room temperature (22° C $\pm 3^{\circ}$ C).

S-330.xSL with cable splitter box; dimensions in mm.

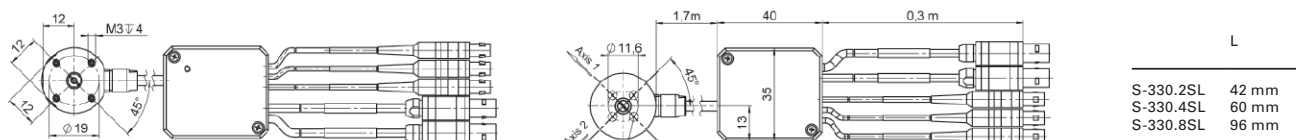

S-331 Fast Tip / Tilt Platform

Short Settling Time and High Dynamic Linearity



- Tip / tilt angle up to 5 mrad, optical deflection angle up to 10 mrad (0.57°)
- Parallel kinematic design for identically high performance characteristics for both tip / tilt axes
- High resonant frequencies for dynamic motion and fast step-and-settle
- Position sensors for high linearity
- For mirrors up to \varnothing 12.7 mm (0.5")

S-331, dimensions in mm.

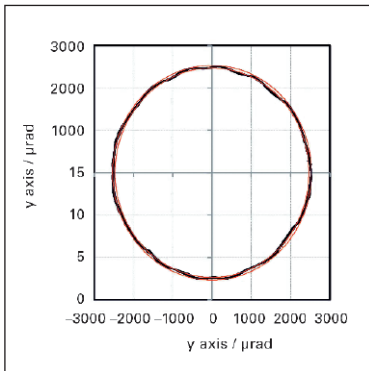
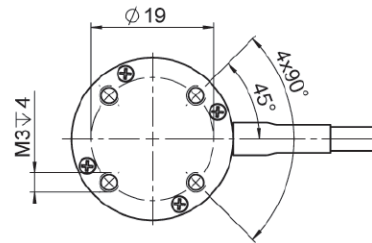

High dynamic linearity of a circular motion with 5 mrad displacement per axis (full displacement of the S 311.5SL with E-505 power amplifier and E-509 controller). The linear error on the ideal circular path at a frequency of 25 Hz is approx. 0.5 %, which corresponds to 2.5 μ rad.

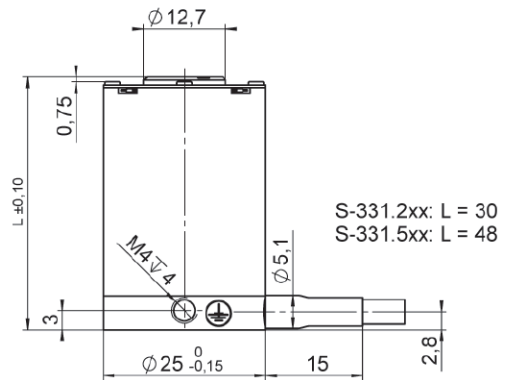

S-331.xSL with cable splitter box; dimensions in mm.

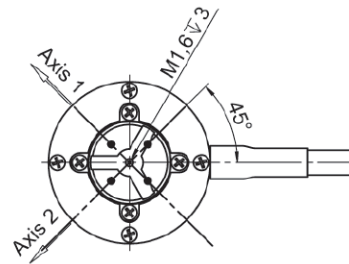
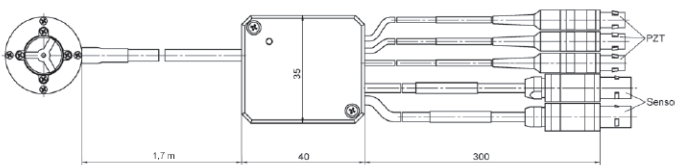

Applications

- Image processing / stabilization
- Optical trapping
- Laser scanning / beam steering
- Laser tuning
- Optical filters / switches
- Optics
- Beam stabilization

- >> Flexure Guiding Systems
- >> Parallel-Kinematic Piezo Stages
- >> PICMA® Multilayer Piezo Actuators

Technology Glossary page 240

	S-331.2SL / S-331.2SH	S-331.5SL / S-331.5SH	Unit	Tolerance
Active axes	θ_x, θ_y	θ_x, θ_y		
Motion and positioning				
Integrated sensor	SGS	SGS		
Open-loop tip / tilt angle in θ_x, θ_y at -20 to 120 V	4.2	7	mrad	min.
Closed-loop tip / tilt angle in θ_x, θ_y	3	5	mrad	
Open-loop resolution in θ_x, θ_y	0.05	0.1	μ rad	typ.
Closed-loop resolution in θ_x, θ_y	0.1	0.25	μ rad	typ.
Linearity error in θ_x, θ_y	0.3 * 0.1 **	0.3 * 0.1 **	nm	typ.
Repeatability in θ_x, θ_y 10 % tip / tilt angle	0.3	0.5	μ rad	typ.
Repeatability in θ_x, θ_y 100 % tip / tilt angle	3	5	nm	typ.
Mechanical properties				
Resonant frequency, unloaded in θ_x, θ_y	12	16	μ rad	typ.
Resonant frequency, unloaded in θ_x, θ_y (with glass mirror, \varnothing 12.7 mm, thickness 3 mm)	9	10		
Distance of pivot point to platform surface	4	4	kHz	± 20 %
Platform moment of inertia	30	30	kHz	± 20 %
Drive properties				
Ceramic type	PICMA®	PICMA®	mm	± 1 mm
Electrical capacitance	0.96 / axis	6.2 / axis	$\text{g} \times \text{mm}^2$	± 20 %
Miscellaneous				
ID chip functionality	S-331.2SH	S-331.5SH	μF	± 20 %
Operating temperature range	-20 to 80	-20 to 80		
Material housing	Steel	Steel		
Material platform	Titanium	Titanium	$^{\circ}\text{C}$	
Mass	0.13	0.28		
Cable length	2	2		
Sensor / voltage connection	0.13	0.28	kg	± 5 %
Recommended electronics	2	2	m	+100 mm / -0 mm
Sensor / voltage connection	LEMO (S-331.2SL), Sub-D 37 (m) (S-331.2SH)	LEMO (S-331.5SL), Sub-D 37 (m) (S-331.5SH)		
Recommended electronics	E-503, E-727	E-503, E-727		

* S-331.xSL in conjunction with E-5xx analog controller modules

** S-331.xSH in conjunction with digital controllers, unidirectional

All specifications based on room temperature (22 $^{\circ}\text{C} \pm 3$ $^{\circ}\text{C}$).

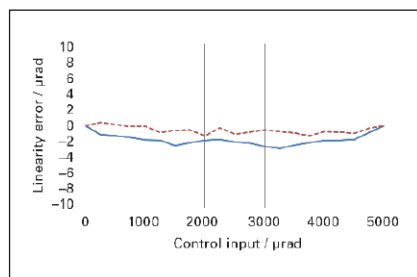

Unidirectional linearity error for both axes: The blue, solid line represents axis 1, the brown, dotted line represents axis 2. The linearity error at full displacement of the S-331.5SH with an E-727.3SD digital piezo controller is less than 0.05 %.

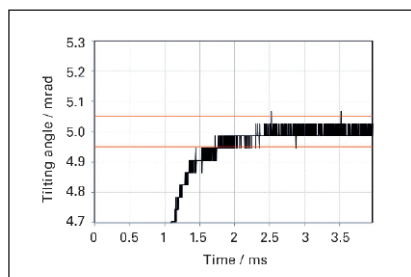

Settling time of an unloaded S-331.5SL at full displacement with E-505 piezo amplifier and the E-509 servo controller: The settling time for a step of 5 mrad is 1.8 ms at accuracy of ± 1 %.

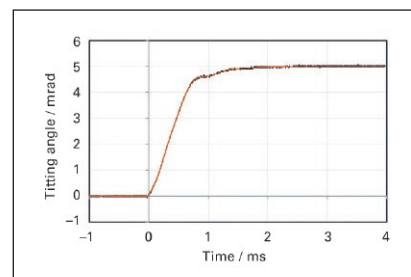

The settling time of the unloaded S-331.5SL for one 5 mrad step (full displacement) is 1.8 ms with an accuracy of ± 1 %.

S-335 Fast Tip / Tilt Platform

Short Settling Time and High Dynamic Linearity

- Tip / tilt angle to 35 mrad, high optical deflection angle to 70 mrad (4°)
- High resonant frequencies for dynamic motion and fast step-and-settle
- Parallel-kinematic design: Two orthogonal tip / tilt axes with one common center of rotation
- Strain sensors for high linearity
- For mirrors to \varnothing 25.4 mm (1") (can be supplied with mirror on request)

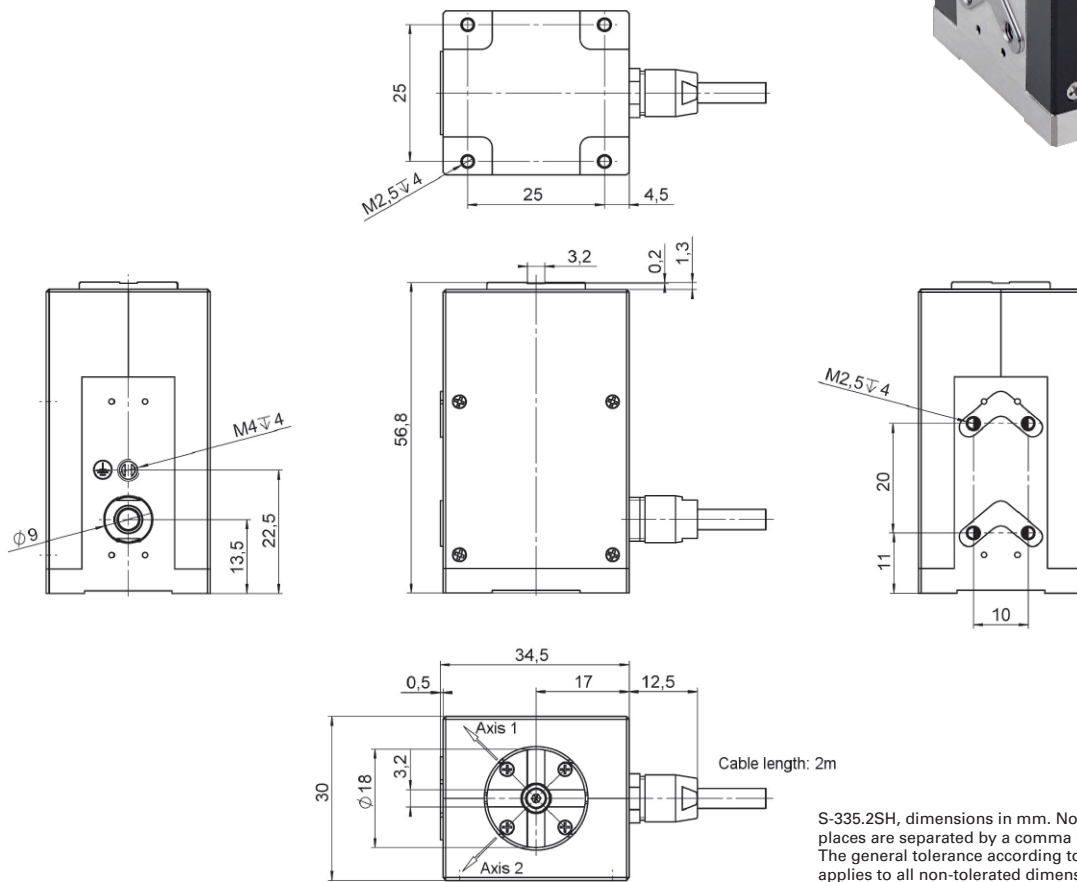

S-335.2SH, dimensions in mm. Note that the decimal places are separated by a comma in the drawings. The general tolerance according to DIN ISO 2768-f-H applies to all non-tolerated dimensions.

Applications

- Image processing / stabilization
- Optical trapping
- Laser scanning / beam steering with large angles
- Laser tuning
- Optical filters / switches
- Optics
- Beam stabilization

- >> Flexure Guiding Systems
- >> Parallel-Kinematic Piezo Stages
- >> PICMA® Multilayer Piezo Actuators

Technology Glossary page 240

	S-335.2SH	Unit	Tolerance
Active axes	θ_x, θ_y		
Motion and positioning			
Integrated sensor	SGS		
Tip / tilt angle, closed loop (static motion at 0 to 120 V)	± 17.5	mrad	
Open-loop resolution	0.1	μrad	typ.
Closed-loop resolution	1.0	μrad	typ.
Linearity	0.05 (unidirectional)	%	typ.
Repeatability	1 (bidirectional)	μrad	typ.
Mechanical properties			
Resonant frequency, no load	2	kHz	$\pm 20\%$
Resonant frequency, under load (with $\varnothing 12.7\text{ mm} \times 3\text{ mm}$ Zerodur mirror)	1.6	kHz	$\pm 20\%$
Resonant frequency, under load (with $\varnothing 25.4\text{ mm} \times 5\text{ mm}$ Zerodur mirror)	0.7	kHz	$\pm 20\%$
Gap between the center of rotation and platform surface	3.3	mm	$\pm 0.25\text{ mm}$
Drive properties			
Ceramic type	PICMA® P-885		
Electrical capacitance per axis	6.2	μF	$\pm 20\%$
Miscellaneous			
ID chip functionality	Yes		
Operating temperature range*	-20 to 80	$^{\circ}\text{C}$	
Material platform	Titanium		
Mass (with cable and connector)	280	g	$\pm 5\%$
Cable length	2	m	+0.1 m
Sensor / voltage connection	Sub-D 37 (m)		
Recommended electronics	E-727		

* The specifications apply to $21\text{ }^{\circ}\text{C} \pm 10\text{ }^{\circ}\text{C}$, specifications may deviate outside of this range. If you have any questions, contact your PI representative.

S-340 Piezo Tip / Tilt Platform

High-Dynamics for Mirrors and Optics up to Ø 75 mm (3 inch)

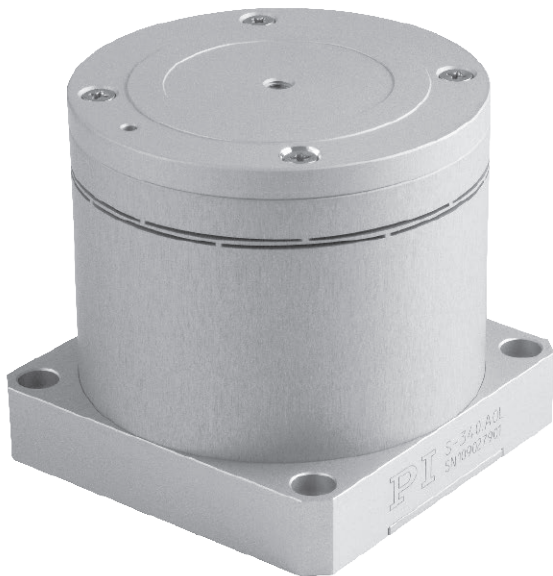

- Resolution up to 20 nrad, excellent position stability
- Optical beam deflection to 4 mrad
- Parallel kinematics for higher accuracy and dynamics
- Sub-ms response time
- For mirrors up to Ø 75 mm (3 inch); Ø 100 mm (4 inch) on request
- Closed-loop versions for improved linearity
- Excellent temperature stability

S-340, dimensions in mm.
The general tolerance according to DIN ISO 2768-f-H applies to all non-tolerated dimensions.

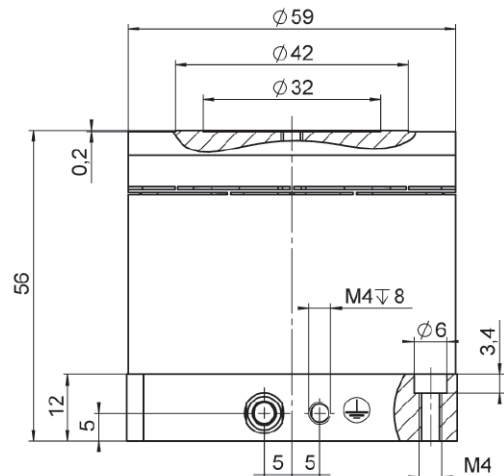
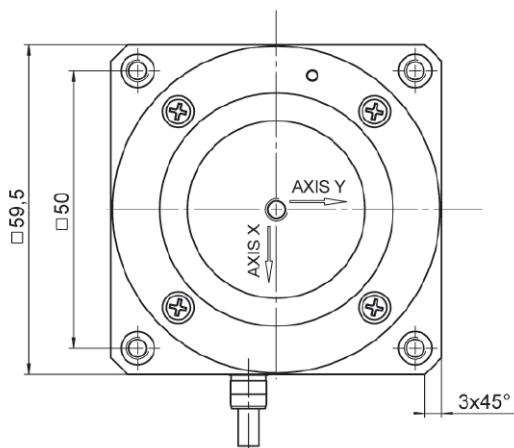

Applications

- Image processing / stabilization
- Optical trapping
- Laser scanning / beam steering with large angles
- Laser tuning
- Optical filters / switches
- Optics
- Beam stabilization

- >> Flexure Guiding Systems
- >> Parallel-Kinematic Piezo Stages
- >> PICMA® Multilayer Piezo Actuators

Technology Glossary page 240

	S-340.ASD / ASL	S-340.A0L	Unit	Tolerance
Active axes	θ_x, θ_y	θ_x, θ_y		
Motion and positioning				
Integrated sensor	SGS	-		
Open-loop tip / tilt angle in θ_x, θ_y -20 to +120 V	2	2	mrad	min.
Closed-loop tip / tilt angle in θ_x, θ_y	2	-	mrad	
Open-loop tip / tilt angle resolution in θ_x, θ_y	0.02	0.02	μ rad	typ.
Closed-loop tip / tilt angle resolution in θ_x, θ_y	0.2	-	μ rad	typ.
Linearity error in θ_x, θ_y	0.1	-	%	typ.
Repeatability in θ_x, θ_y	0.15	-	μ rad	typ.
Mechanical properties				
Unloaded resonant frequency in θ_x, θ_y	1.4	1.4	kHz	± 20 %
Resonant frequency loaded in θ_x, θ_y (with glass mirror, diameter 50 mm, thickness 15 mm)	0.9	0.9	kHz	± 20 %
Resonant frequency loaded in θ_x, θ_y (with glass mirror, diameter 75 mm, thickness 22 mm)	0.4	0.4	kHz	± 20 %
Distance of pivot point to platform surface	7.5	7.5	mm	± 1 mm
Platform moment of inertia	18000	18000	$g \times mm^2$	± 20 %
Drive properties				
Ceramic type	PICMA®	PICMA®		
Electrical capacitance	6 / axis	6 / axis	μ F	± 20 %
Miscellaneous				
Operating temperature range	-20 to 80	-20 to 80	°C	
Material case	Aluminum	Aluminum		
Material platform	Aluminum; or optionally Steel, Titanium or Invar	Aluminum; or optionally Steel, Titanium or Invar		
Mass	0.355	0.35	kg	± 5 %
Cable length	2	2	m	+100 mm / -0 mm
Sensor / voltage connection	Sub-D 25 (m) / LEMO	LEMO		
Recommended electronics	E-616, E-727	E-616, E-727		

All specifications based on room temperature (22 °C \pm 3 °C).

Piezo Actuators with Guiding and Preload

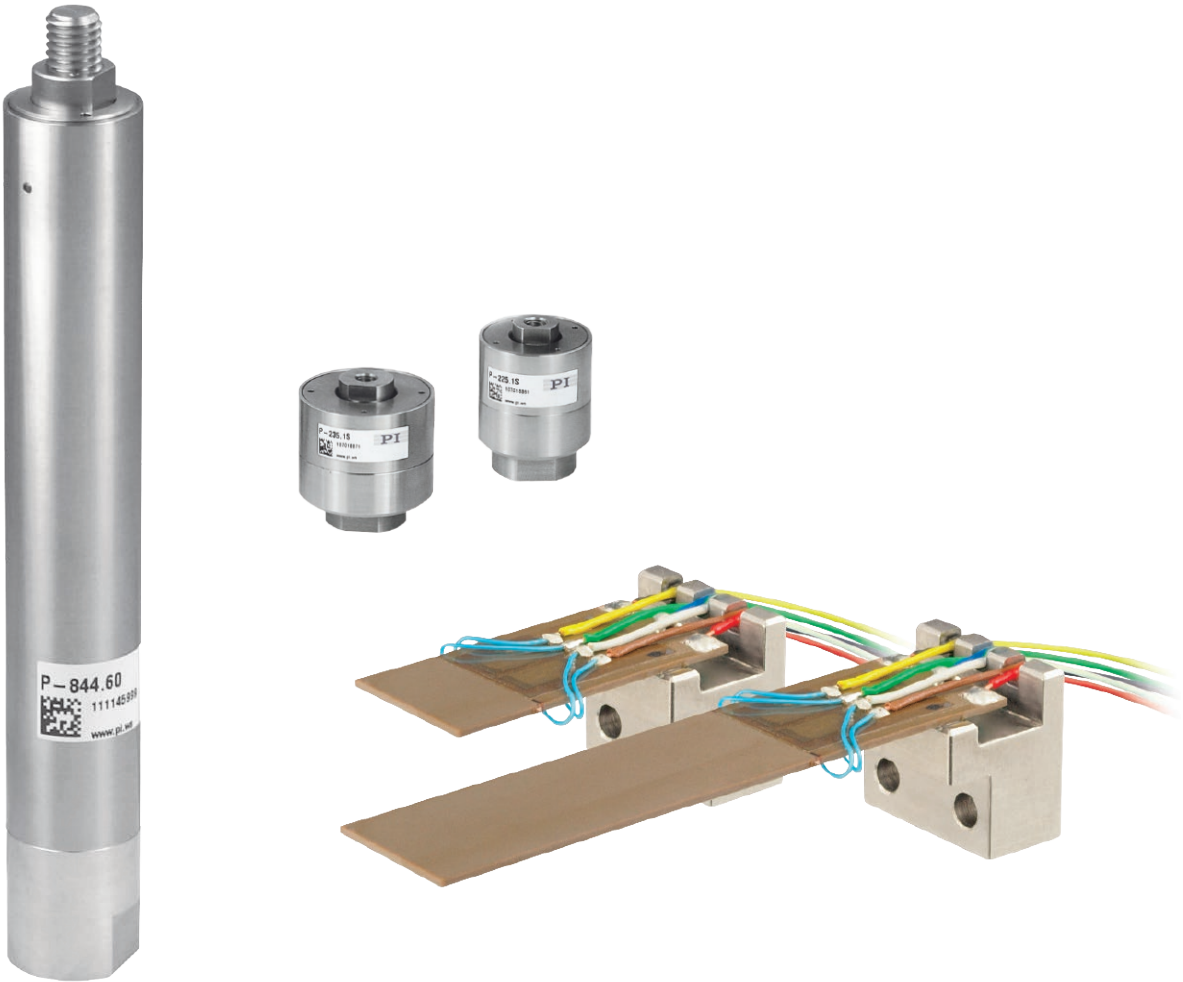

PiezoMove Lever Actuators	118
P-601 PiezoMove Flexure-Guided Linear Actuator	120
P-602 PiezoMove High-Stiffness Linear Piezo Actuator	122
P-603 Cost-Efficient PiezoMove Linear Flexure Actuator	124
P-604 Compact PiezoMove Linear Actuator	126

Preloaded Actuators with Low Drive Voltage to 100 V	128
P-810 / P-830 Piezo Actuators	128
P-820 Preloaded Piezo Actuators	130
P-855 Piezo Fine Adjustment Drive for Micrometer Screws	132
P-840 / P-841 Preloaded Piezo Actuators	134
P-842 Preloaded Piezo Actuators	136
P-843 Preloaded Piezo Actuators	138
P-844 Preloaded Piezo Actuators	140
P-845 Preloaded Piezo Actuators	142
P-853 / P-854 Piezoelectric Micrometer Drive	144

Preloaded Actuators with High Drive Voltage to 1000 V	146
P-212 PICA Power Piezo Actuator	146
P-216 PICA Power Piezo Actuator	148
P-225 PICA Power Piezo Actuators	150
P-235 PICA Power Piezo Actuators	152
P-286 / P-288 / P-289 Disk Translators	154

Piezo Benders	156
P-871 PICMA® Multilayer Bending Actuators	156

P-601

PiezoMove Flexure-Guided Linear Actuator

With Optional Position Sensor

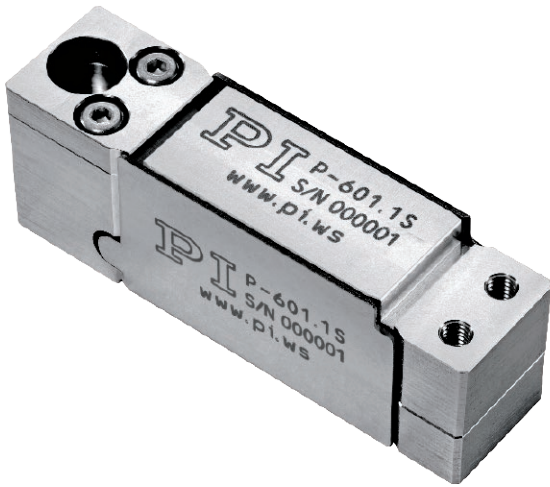

P-601, dimensions in mm.

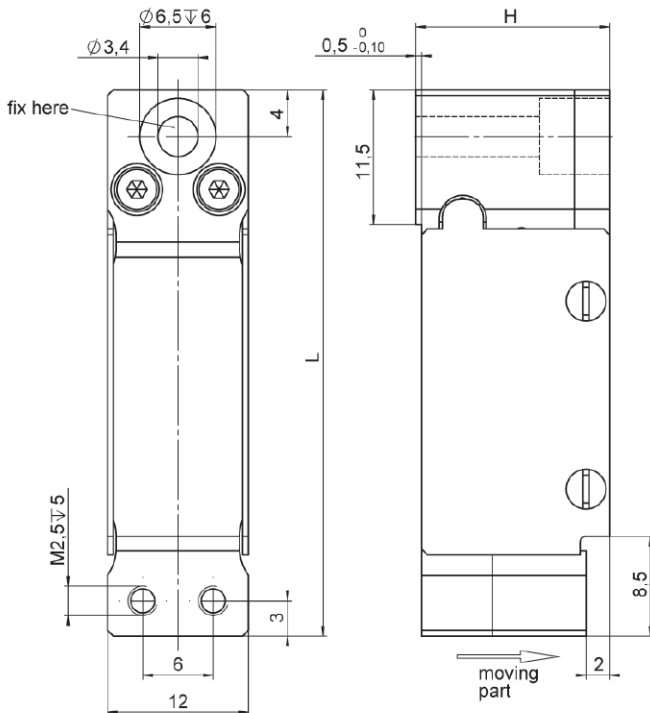

- Flexure guides for linear motion with minimum tip and tilt
- Travel ranges to 400 μ m
- Resolution to 0.2 nm
- Available with integrated position sensor
- Outstanding lifetime due to PICMA[®] piezo actuators
- Ideal OEM actuators for precision motion control in optics, medical, biotech and microfluidics applications
- Custom designs with larger travel or faster response and non-magnetic versions feasible

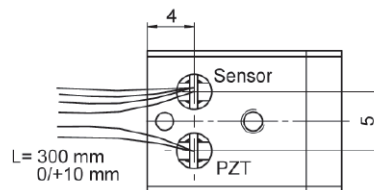

	H	L
P-601.1x	16,5	46,5
P-601.3x	18,0	64,5
P-601.4x	20,5	82,5

Applications

- Nanopositioning
- High-speed switching
- Patch clamp
- Micro-dispensing
- Adaptronics / Automation
- Photonics / integrated optics
- Biotechnology

- >> Flexure Guiding Systems
- >> PICMA[®] Multilayer Piezo Actuators

Technology Glossary page 240

	P-601.1S P-601.1SL	P-601.3S P-601.3SL	P-601.4S P-601.4SL	P-601.x0 P-601.x0L open-loop versions	Unit	Tolerance
Active axes	Z	Z	Z	Z		
Motion and positioning						
Integrated sensor	SGS	SGS	SGS	–		
Open-loop travel, –20 to 120 V	100	250	400	as P-601.xS	µm	+20 % / –0 %
Closed-loop travel	100	250	400	–	µm	calibrated
Open-loop resolution	0.2	0.3	0.4	as P-601.xS	nm	typ.
Closed-loop resolution	2	6	12	–	nm	typ.
Closed-loop nonlinearity	0.1	0.3	0.3	–	%	typ.
Repeatability	8	10	30	–	nm	typ.
Mechanical properties						
Stiffness in motion direction	0.8	0.38	0.28	as P-601.xS	N/µm	±20 %
Unloaded resonant frequency	750	440	350	as P-601.xS	Hz	±20 %
Resonant frequency at 30 g	620	350	290	as P-601.xS	Hz	±20 %
Push / pull force capacity in motion direction	30 / 10	20 / 10	15 / 10	as P-601.xS	N	max.
Lateral force	30	30	30	as P-601.xS	N	max.
Drive properties						
Ceramic type	PICMA® P-885	PICMA® P-885	PICMA® P-885	as P-601.xS		
Electrical capacitance	1.5	3.1	4.6	as P-601.xS	µF	±20 %
Miscellaneous						
Operating temperature range	–20 to 80	–20 to 80	–20 to 80	–20 to 80	°C	
Material	Stainless steel	Stainless steel	Stainless steel	Stainless steel		
Mass without cables	0.05	0.08	0.11	as P-601.xS	kg	±5 %
Cable length	S versions: 0.3 m SL versions: 1.5 m	S versions: 0.3 m SL versions: 1.5 m	S versions: Stranded wires SL versions: LEMO	x0 versions: Stranded wires x0L versions: LEMO	0.3 m	
Sensor / voltage connection	S versions: Stranded wires SL versions: LEMO	S versions: Stranded wires SL versions: LEMO	S versions: Stranded wires SL versions: LEMO	x0 versions: Stranded wires x0L versions: LEMO		
Recommended electronics	E-610, E-625, E 831	E-610, E-625, E 831	E-610, E-625, E 831	E-610, E-625, E 831		

All specifications based on room temperature (22 °C ±3 °C).

Direction of motion of the P-601.
The flexure guiding system prevents tip
and tilt at the drive head.

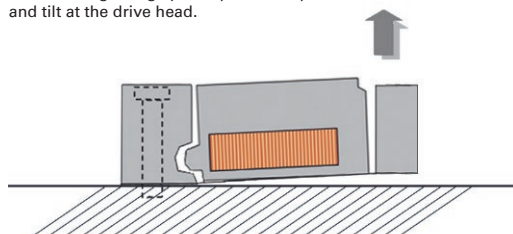

P-602

PiezoMove High-Stiffness Linear Piezo Actuator

With Flexure-Guided Motion Amplifier for Travel Ranges to 1 mm

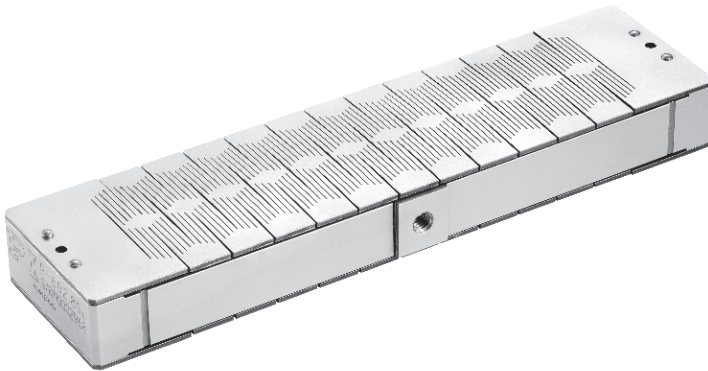

- Flexure guides for linear motion with minimum tip and tilt
- Travel ranges to 1 mm
- Forces to 100 N
- Stiff and backlash-free construction
- Available with integrated position sensor
- Outstanding lifetime due to PICMA® piezo actuators
- Ideal OEM actuator for force generation in adaptive systems technology, for nanoimprint processes or machine tools
- Custom designs with larger travel or faster response and non-magnetic versions feasible

P-602, dimensions in mm.

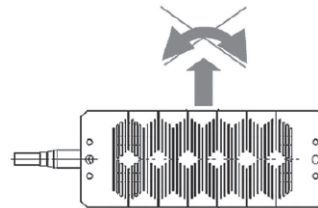
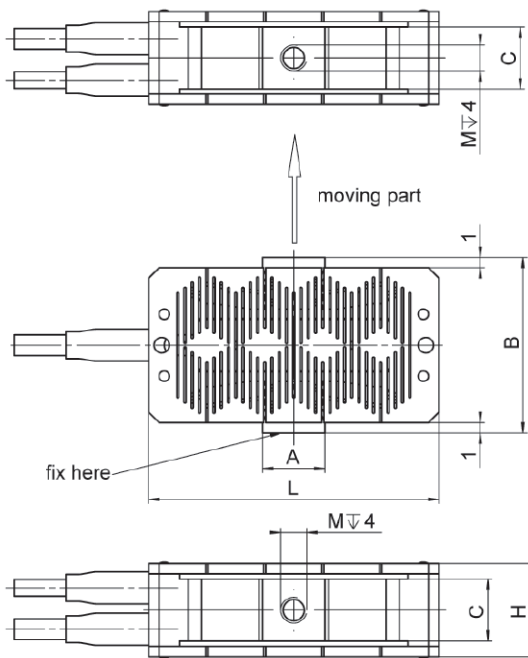

Flexure guides provide straight motion with no tip and minimum tilt.

	L	B	H	M	A	C
P-602.1xx	28	17	9	M2,5	6	6
P-602.3xx	46	19	9	M2,5	6	6
P-602.5xx	85	26	9	M2,5	6	6
P-602.8xx	126	34	14	M4	10	11
P-602.1x8	28	22	14	M2,5	6	11
P-602.3x8	46	24	14	M2,5	6	11
P-602.5x8	85	31	14	M2,5	6	11

Applications

- Nanopositioning
- High-speed switching
- Patch clamp
- Micro-dispensing
- Adaptronics / Automation
- Photonics / integrated optics
- Biotechnology

- >> Flexure Guiding Systems
- >> PICMA® Multilayer Piezo Actuators

Technology Glossary page 240

	P-602.100 / P-602.1S0 / P-602.1SL	P-602.300 / P-602.3S0 / P-602.3SL	P-602.500 / P-602.5S0 / P-602.5SL	P-602.108 / P-602.1S8 / P-602.1L8	P-602.308 / P-602.3S8 / P-602.3L8	P-602.508 / P-602.5S8 / P-602.5L8	P-602.800 / P-602.8S0 / P-602.8SL	Unit
Active axes	X	X	X	X	X	X	X	
Motion and positioning								
Integrated sensor	- / SGS / SGS	- / SGS / SGS	- / SGS / SGS	- / SGS / SGS	- / SGS / SGS	- / SGS / SGS	- / SGS / SGS	
Open-loop travel, -20 to 120 V	120	300	600	100	300	500	1000	µm
Closed-loop travel	- / 100 / 100	- / 300 / 300	- / 500 / 500	- / 100 / 100	- / 300 / 300	- / 500 / 500	- / 1000 / 1000	µm
Open-loop resolution	0.2	0.3	0.4	0.2	0.3	0.4	0.5	nm
Closed-loop resolution	- / 2 / 2	- / 3 / 3	- / 3 / 3	- / 2 / 2	- / 3 / 3	- / 3 / 3	- / 7 / 7	nm
Closed-loop nonlinearity	- / 0.5 / 0.5	- / 0.5 / 0.5	- / 0.5 / 0.5	- / 0.5 / 0.5	- / 0.5 / 0.5	- / 0.5 / 0.5	- / 1.5 / 1.5	%
Repeatability	- / 10 / 10	- / 20 / 20	- / 35 / 35	- / 10 / 10	- / 20 / 20	- / 35 / 35	- / 60 / 60	nm
Mechanical properties								
Stiffness in motion direction	0.8	0.35	0.3	2.3	0.75	0.65	0.4	N/µm
Unloaded resonant frequency	1000	450	230	1000	450	230	150	Hz
Push force capacity in motion direction	100	100	100	100	100	100	100	N
Pull force capacity in motion direction	5	5	5	5	5	5	5	N
Drive properties								
Piezoceramics	PICMA® P-885	PICMA® P-885	PICMA® P-885	PICMA® P-888	PICMA® P-888	PICMA® P-888	PICMA® P-888	
Electrical capacitance	1.5	3.1	6.2	6	13	26	39	µF
Miscellaneous								
Operating temperature range	-20 to 80	-20 to 80	-20 to 80	-20 to 80	-20 to 80	-20 to 80	-20 to 80	°C
Material	Stainless steel	Stainless steel	Stainless steel	Stainless steel	Stainless steel	Stainless steel	Stainless steel	
Dimensions	28 mm × 17 mm × 9 mm	46 mm × 19 mm × 9 mm	8 mm × 26 mm × 9 mm	28 mm × 22 mm × 14 mm	46 mm × 24 mm × 14 mm	85 mm × 31 mm × 14 mm	126 mm × 34 mm × 14 mm	
Mass	0.02	0.04	0.105	0.05	0.088	0.215	0.355	kg
Cable length	0.5 / 0.5 / 2	0.5 / 0.5 / 2	0.5 / 0.5 / 2	0.5 / 0.5 / 2	0.5 / 0.5 / 2	0.5 / 0.5 / 2	0.5 / 0.5 / 2	m
Power / sensor connector	Stranded wires / Stranded wires / LEMO	Stranded wires / Stranded wires / LEMO	Stranded wires / Stranded wires / LEMO	Stranded wires / Stranded wires / LEMO	Stranded wires / Stranded wires / LEMO	Stranded wires / Stranded wires / LEMO	Stranded wires / Stranded wires / LEMO	
Recommended electronics	E-610, E-625, E-831	E-610, E-625, E-831	E-610, E-625, E-831	E-610, E-625, E-831	E-610, E-625, E-831	E-610, E-625, E-831	E-610, E-625, E-831	

All specifications based on room temperature (22 °C ±3 °C).

P-603

Cost-Efficient PiezoMove Linear Flexure Actuator

Frictionless Guidings and Travel Ranges to 0.5 mm

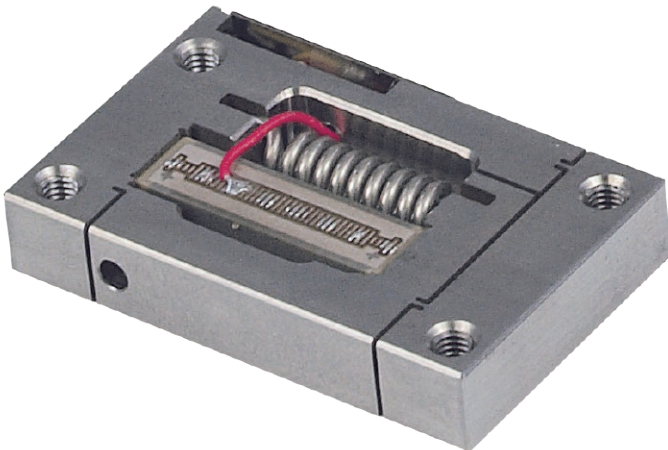

P-603, dimensions in mm.

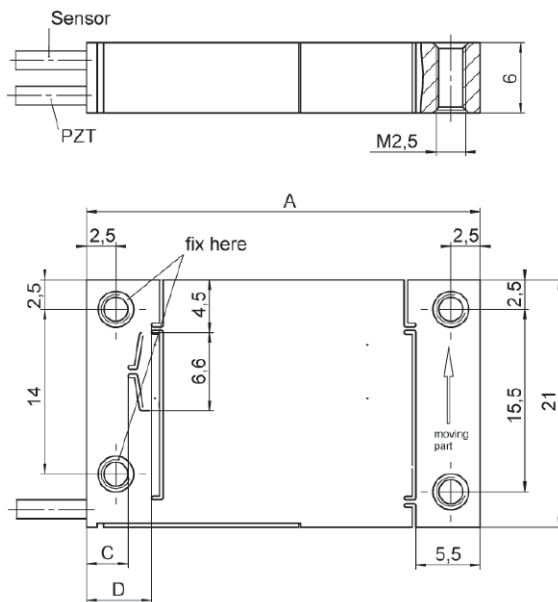

	A [mm]	C [mm]	D [mm]
P-603.1S1 / .1S2 / .101	33,5	3,5	5,5
P-603.3S1 / .3S2 / .301	52	3,5	5,6
P-603.5S1 / .5S2 / .501	62	4,5	6,2

- Flexure guides for linear motion with minimum tip and tilt
- Travel ranges to 500 μm
- Optimized design for manufacturing in large quantities
- Available with integrated position sensor
- Outstanding lifetime due to PICMA[®] piezo actuators
- Ideal OEM actuators for precision motion control in optics, medical, biotech and micro-fluidics applications
- Custom designs with larger travel or faster response and non-magnetic versions feasible

Direction of motion of the P-603. The flexure guiding system prevents tip and tilt at the drive head.

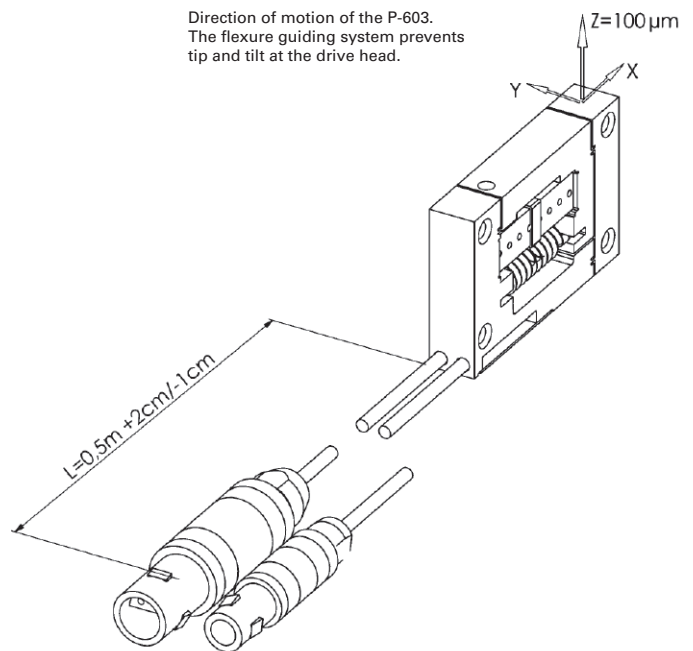

Applications

- Nanopositioning
- High-speed switching
- Patch clamp
- Micro-dispensing
- Adaptronics / Automation
- Photonics / integrated optics
- Biotechnology

- >> Flexure Guiding Systems
- >> PICMA[®] Multilayer Piezo Actuators

Technology Glossary page 240

	P-603.1S1 P-603.1S2	P-603.3S1 P-603.3S2	P-603.5S1 P-603.5S2	P-603.x01 open-loop versions	Unit
Active axes	Z	Z	Z	Z	
Motion and positioning					
Integrated sensor	SGS	SGS	SGS	–	
Open-loop travel, –20 to 120 V	120	380	550	as P-603.xS1	µm
Closed-loop travel	100	300	500	–	µm
Open-loop resolution, 180 g	2	3	5	as P-603.xS1	nm
Closed-loop resolution, 180 g	6	8	10	–	nm
Closed-loop nonlinearity	0.2	0.2	0.2	–	%
Unidir. Repeatability, 10 %, 1 Sigma	7	10	20	–	nm
Mechanical properties					
Stiffness in motion direction	0.3	0.14	0.06	as P-603.xS1	N/µm
Unloaded resonant frequency	900	410	300	as P-603.xS1	Hz
Resonant frequency at 180 g	160	110	80	as P-603.xS1	Hz
Push / pull force capacity in motion direction	40 / 20	35 / 13	30 / 10	as P-603.xS1	N
Drive properties					
Piezoceramics	PICMA® P-885	PICMA® P-885	PICMA® P-885	as P-603.xS1	
Electrical capacitance	1.5	3.1	3.7	as P-603.xS1	µF
Miscellaneous					
Operating temperature range	–20 to 80	–20 to 80	–20 to 80	as P-603.xS1	°C
Material	Stainless steel	Stainless steel	Stainless steel	as P-603.xS1	
Dimensions	33.5 mm × 21 mm × 6 mm	52 mm × 21 mm × 6 mm	62 mm × 21 mm × 6 mm	as P-603.xS1	
Mass	S1-version: 0.03 S2-version: 0.04	S1-version: 0.04 S2-version: 0.05	S1-version: 0.05 S2-version: 0.06	as P-603.xS1	kg
Cable length	0.5	0.5	0.5	as P-603.xS1	m
Sensor connection	S1 versions: Wire leads S2 versions: LEMO (strain gauge sensor)	S1 versions: Wire leads S2 versions: LEMO (strain gauge sensor)	S1 versions: Wire leads S2 versions: LEMO (strain gauge sensor)	–	
Voltage connection	S1 versions: Wire leads S2 versions: LEMO (low voltage)	S1 versions: Wire leads S2 versions: LEMO (low voltage)	S1 versions: Wire leads S2 versions: LEMO (low voltage)	as P-603.xS1	
Recommended electronics	E-610, E-831	E-610, E-831	E-610, E-831	E-610, E-831	

All specifications based on room temperature (22 °C ±3 °C).

P-604 Compact PiezoMove Linear Actuator

Cost-Efficient, with 300 μm Travel Range

- Lightweight and compact: 4 g and $13 \text{ mm} \times 20 \text{ mm}$ footprint
- Travel range 300 μm
- Optimized design for manufacturing in large quantities
- Customer-specific adaptations can be provided
- Outstanding lifetime due to PICMA[®] piezo actuators
- Ideal OEM actuators for precision motion control in optics, medical, biotech and microfluidics applications

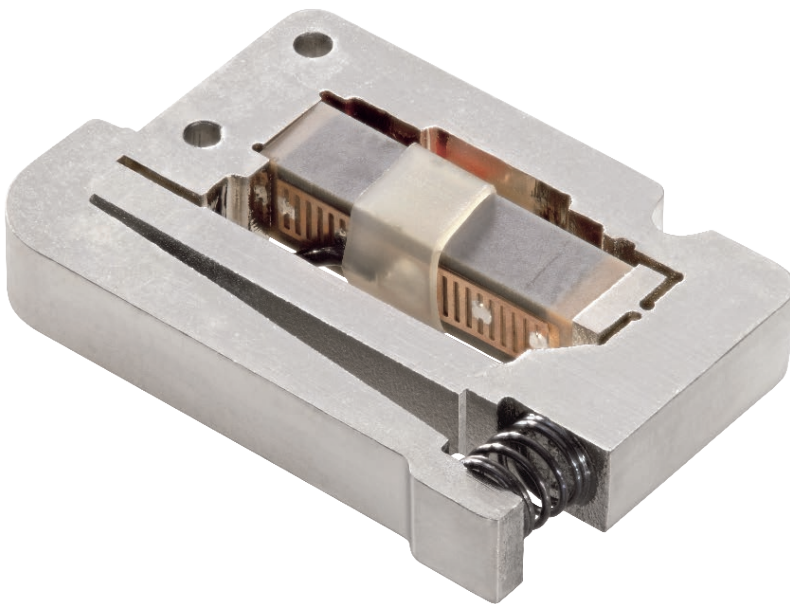

P-604, dimensions in mm.

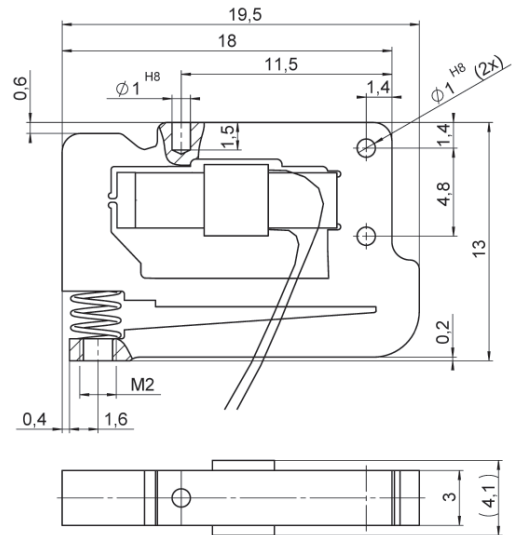

Applications

- Nanopositioning
- High-speed switching
- Patch clamp
- Micro-dispensing
- Adaptronics / Automation
- Photonics / integrated optics
- Biotechnology

- >> Flexure Guiding Systems
- >> PICMA[®] Multilayer Piezo Actuators

Technology Glossary page 240

	P-604.300	Unit	Tolerance
Active axes	Z		
Motion and positioning			
Open-loop travel, -20 to 120 V	300	μm	+20 % / -0 %
Open-loop resolution	0.5	nm	typ.
Mechanical properties			
Stiffness in motion direction	0.01	N/μm	±20 %
Unloaded resonant frequency	900	Hz	±20 %
Push / pull force capacity in motion direction	2 / 1.5	N	max.
Drive properties			
Piezoceramics	PICMA® P-883		
Electrical capacitance	0.27	μF	±20 %
Miscellaneous			
Operating temperature range	-20 to 80	°C	
Material	Steel		
Dimensions	19.5 mm × 13 mm × 4.1 mm		
Mass	4	g	±10 %
Cable length	0.1	m	±10 mm
Voltage connection	Stranded wire		
Recommended electronics	E-610, E-831		

All specifications based on room temperature (22 °C ±3 °C).
Ask about custom designs!

P-810 / P-830 Piezo Actuators

For Light and Medium Loads



- Outstanding lifetime due to PICMA® piezo actuators
- Travel range to 60 µm
- Push forces to 1000 N
- Pull forces to 5 N
- Microsecond response
- Subnanometer resolution

P-810, dimensions in mm.
Two braids Teflon insulated, length 0.1 m.

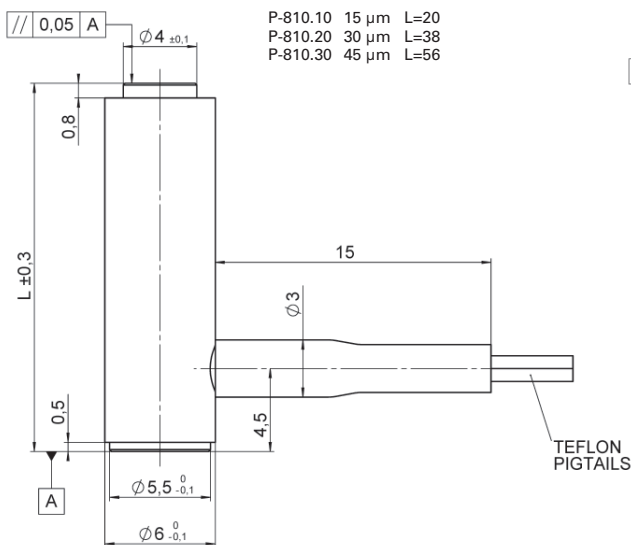

P-830, dimensions in mm.
Two braids Teflon insulated, length 0.1 m.

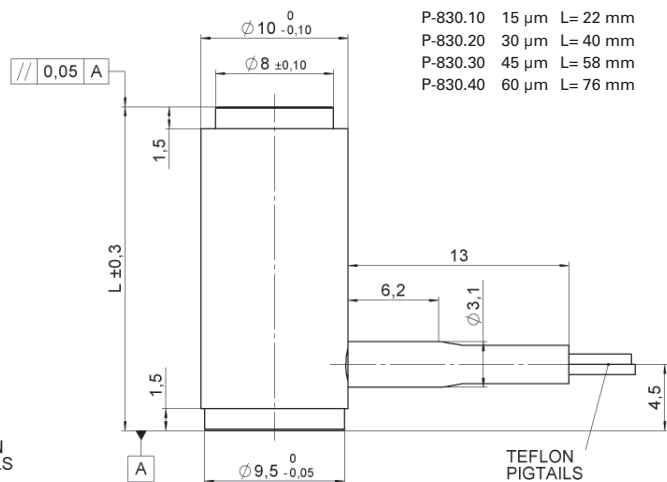

Applications

- Static and dynamic precision positioning
- Fiber positioning
- Laser tuning
- Patch-Clamp
- Nanotechnology

>> PICMA® Multilayer Piezo Actuators

Technology Glossary page 240

	P-810.10	P-810.20	P-810.30	P-830.10	P-830.20	P-830.30	P-830.40	Unit	Tolerance	
Travel range at 0 to 100 V	15	30	45	15	30	45	60	µm	±20 %	
Resolution*	0.15	0.3	0.45	0.15	0.3	0.45	0.6	nm		
Static large-signal stiffness**	14	7	4	57	27	19	15	N/µm	±20 %	
Push / pull force capacity	50 / 1	50 / 1	50 / 1	1000 / 5	1000 / 5	1000 / 5	1000 / 5	N		
Electrical capacitance	0.3	0.7	1	1.5	3	4.5	6	µF	±20 %	
Resonant frequency f_0 (no load)	22	15	12	23	14	10	8.5	kHz	±20 %	
Mass	4	6	8	10	16	21	27	g	±5 %	
Length L	20	38	56	22	40	58	76	mm	±0.3	
Recommended electronics	E-503, E-505, E-610, E-617, E-621, E-625, E-663, E-709, E-831	E-503, E-505, E-610, E-617, E-621, E-625, E-663, E-709, E-831	E-503, E-505, E-610, E-617, E-621, E-625, E-663, E-709, E-831	E-503, E-505, E-610, E-617, E-621, E-625, E-663, E-709, E-831	E-503, E-505, E-610, E-617, E-621, E-625, E-663, E-709, E-831	E-503, E-505, E-610, E-617, E-621, E-625, E-663, E-709, E-831	E-503, E-505, E-610, E-617, E-621, E-625, E-663, E-709, E-831	E-503, E-505, E-610, E-617, E-621, E-625, E-663, E-709, E-831		

* The resolution of piezo actuators is not limited by stiction or friction. Value given is noise equivalent motion with E-503 amplifier.

** Dynamic small-signal stiffness is ~30 % higher. Operating temperature range: -20 to 80 °C.

Case: non-magnetic steel. End pieces: stainless steel. Recommended preload for dynamic operation: 10^{-20} MPa.

All specifications based on room temperature (22 °C ±3 °C).

Ask about custom designs!

P-820 Preloaded Piezo Actuators

For Light and Medium Loads

- Outstanding lifetime due to PICMA® piezo actuators
- Travel range to 45 µm
- Push forces to 50 N
- Pull forces to 10 N
- Microsecond response, subnanometer resolution
- Versions with ball tip



P-820, dimensions in mm.

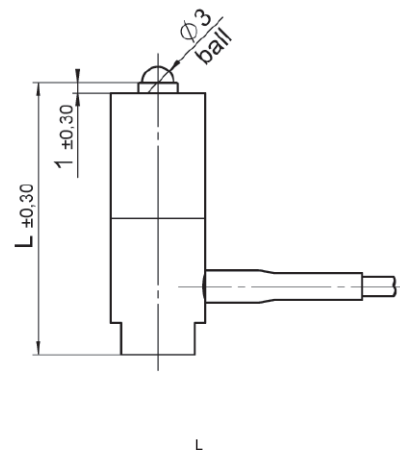
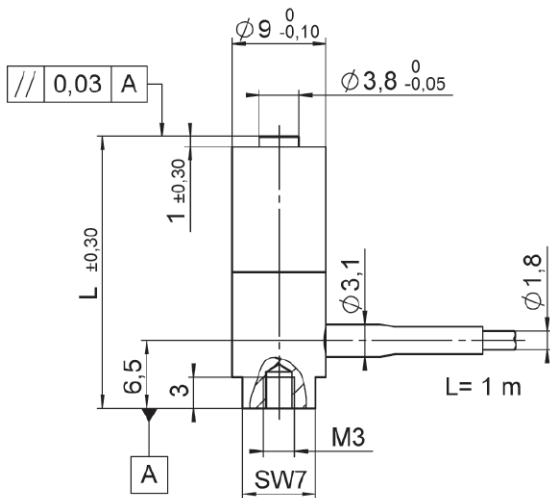

Accessory P-176.30: Magnetic Adapter for P-820, can be glued on the top piece

P-820.10 / P-820.1B	26
P-820.20 / P-820.2B	44
P-820.30 / P-820.3B	62

Applications

- Static and dynamic precision positioning
- Fiber positioning
- Laser tuning
- Nanotechnology

>> PICMA® Multilayer Piezo Actuators

Technology Glossary page 240

	P-820.10 P-820.1B	P-820.20 P-820.2B	P-820.30 P-820.3B	Unit	Tolerance
Travel range at 0 to 100 V	15	30	45	µm	±20 %
Resolution*	0.15	0.3	0.45	nm	
Static large-signal stiffness**	13	7	4	N/µm	±20 %
Push / pull force capacity	50 / 10	50 / 10	50 / 10	N	
Max. torque limit (on tip)	0.08	0.08	0.08	Nm	
Electrical capacitance	0.3	0.7	1.0	µF	±20 %
Resonant frequency f_0 (no load)	22	15	12	kHz	±20 %
Operating temperature	-20 to 80	-20 to 80	-20 to 80	°C	
Mass	8	11	14	g	±5 %
Material case	Non-magnetic steel	Non-magnetic steel	Non-magnetic steel		
Material end pieces	Stainless steel	Stainless steel	Stainless steel		
Length L	26	44	62	mm	±0.3
Recommended electronics	E-503, E-505, E-610, E-617, E-621, E-625, E-663, E-709, E-831	E-503, E-505, E-610, E-617, E-621, E-625, E-663, E-709, E-831	E-503, E-505, E-610, E-617, E-621, E-625, E-663, E-709, E-831		

* The resolution of piezo actuators is not limited by stiction or friction. Value given is noise equivalent motion with E-503 amplifier.

** Dynamic small-signal stiffness is ~30 % higher.

Voltage connection: LEMO FFA.00.250. Coaxial cable, RG 178, 1 m.

All specifications based on room temperature (22 °C ±3 °C).

Ask about custom designs!

P-855 Piezo Fine Adjustment Drive for Micrometer Screws

Micrometer-Mountable Open-Loop Piezo Translator

P-855, dimensions in mm.

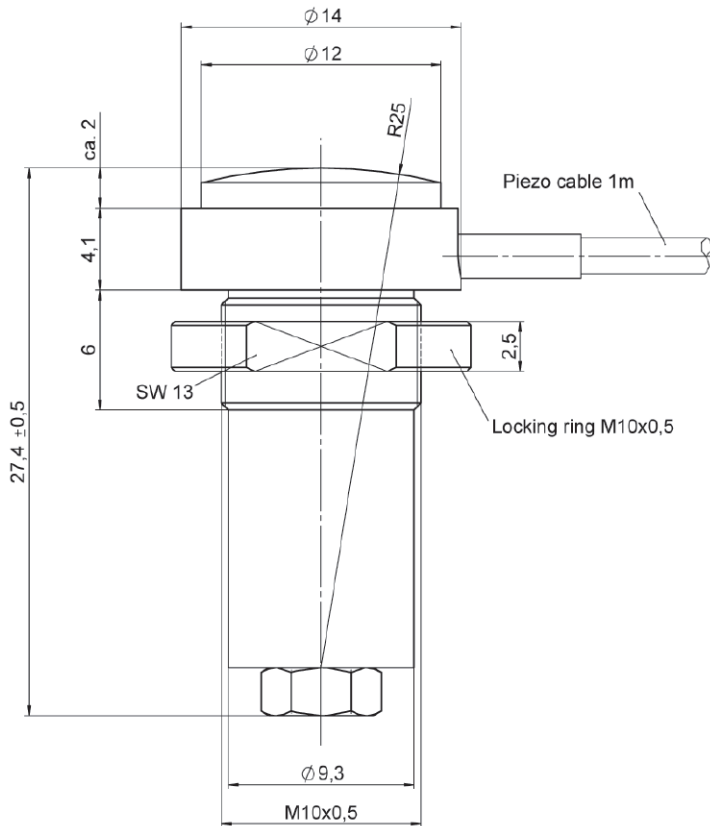

- Travel range 20 μm
- Mounts inside micrometer tip
- Sub-ms response time
- Subnanometer resolution

Applications

- Laser tuning
- Static and dynamic
- Positioning of small parts
- Fiber positioning

>> PICMA® Multilayer Piezo Actuators

Technology Glossary page 240

	P-855.20	Unit	Tolerance
Open-loop travel at -20 to 120 V	20	μm	±20 %
Resolution*	0.2	nm	
Static large-signal stiffness**	48	N/μm	±20 %
Push / pull force capacity	100 / 5	N	
Operating voltage range	-20 to 120	V	
Piezo ceramic type	PICMA®		
Electrical capacitance	1.5	μF	±20 %
Resonant frequency f_0 (no load)	18	kHz	±20 %
Operating temperature	-40 to 80	°C	
Voltage connection	LEMO		
Mass	28	g	±5 %
Recommended electronics	E-610, E-831, E-836		

* The resolution of piezo actuators is not limited by stiction or friction.
Value given is noise equivalent motion with E-505 amplifier.

** Dynamic small-signal stiffness is ~50 % higher.

All specifications based on room temperature (22 °C ±3 °C).

Ask about custom designs!

P-840 / P-841 Preloaded Piezo Actuators

Optional with Integrated Position Sensor



- Outstanding lifetime due to PICMA® piezo actuators
- Travel range to 90 µm
- Compact case
- Push forces to 1000 N
- Pull forces to 50 N
- Microsecond response
- Subnanometer resolution
- Versions with ball tip, vacuum versions

P-840 / P-841, dimensions in mm.

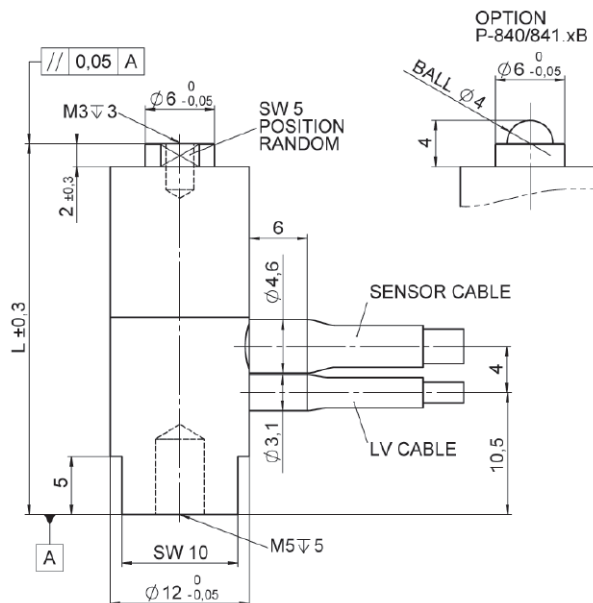

P-840.10/P-841.10	15 µm	L= 32 mm
P-840.20/P-841.20	30 µm	L= 50 mm
P-840.30/P-841.30	45 µm	L= 68 mm
P-840.40/P-841.40	60 µm	L= 86 mm
P-840.60/P-841.60	90 µm	L=122 mm

Accessories P-176.20:
Magnetic Adapter for P-840 and P-841

Applications

- Static and dynamic precision positioning
- Laser tuning
- Fiber positioning
- Nanotechnology

- >> PICMA® Multilayer Piezo Actuators
- >> Vacuum-Compatible Version

Technology Glossary page 240

	P-841.10 / P-840.10*	P-841.20 / P-840.20*	P-841.30 / P-840.30*	P-841.40 / P-840.40*	P-841.60 / P-840.60*	Unit	Tolerance
Open-loop travel, at 0 to 100 V	15	30	45	60	90	μm	±20 %
Closed-loop travel	15 / -	30 / -	45 / -	60 / -	90 / -	μm	
Integrated feedback sensor**	SGS / -	SGS / -	SGS / -	SGS / -	SGS / -		
Resolution, closed-loop / open-loop***	0.3 / 0.15	0.6 / 0.3	0.9 / 0.45	1.2 / 0.6	1.8 / 0.9	nm	
Static large-signal stiffness****	57	27	19	15	10	N/μm	±20 %
Push force capacity	1000	1000	1000	1000	1000	N	
Pull force capacity	50	50	50	50	50	N	
Torque on tip	0.35	0.35	0.35	0.35	0.35	Nm	max.
Electrical capacitance	1.5	3.0	4.5	6.0	9.0	μF	±20 %
Resonant frequency f_0 (no load)	18	14	10	8.5	6	kHz	±20 %
Operating temperature	-20 to 80	-20 to 80	-20 to 80	-20 to 80	-20 to 80	°C	
Mass without cable	20	28	46	54	62	g	±5 %
Material: case, end pieces	N-S, S	N-S, S	N-S, S	N-S, S	N-S, S		
Length L	32	50	68	86	122	mm	±0.3
Recommended electronics	E-503, E-505, E-610, E-617, E-621, E-625, E-663, E-709, E-831	E-503, E-505, E-610, E-617, E-621, E-625, E-663, E-709, E-831	E-503, E-505, E-610, E-617, E-621, E-625, E-663, E-709, E-831	E-503, E-505, E-610, E-617, E-621, E-625, E-663, E-709, E-831	E-503, E-505, E-610, E-617, E-621, E-625, E-663, E-709, E-831		

* P-841.xx: Models with sensor; P-840.xx: Models without sensor.
 ** Closed-loop models can attain linearity up to 0.15 % and are shipped with performance reports.
 *** The position resolution of piezo actuators is not limited by stiction or friction. Value given is noise equivalent motion with E-503 amplifier.
 **** Dynamic small-signal stiffness is approx. 30 % higher.
 Voltage connection: LEMO FFA.00.250. Coaxial cable, RG 178, 1 m.
 Sensor connection (P-841.xx only): LEMO FFA.0S.304. Cable, 1 m.
 All specifications based on room temperature (22 °C ±3 °C).

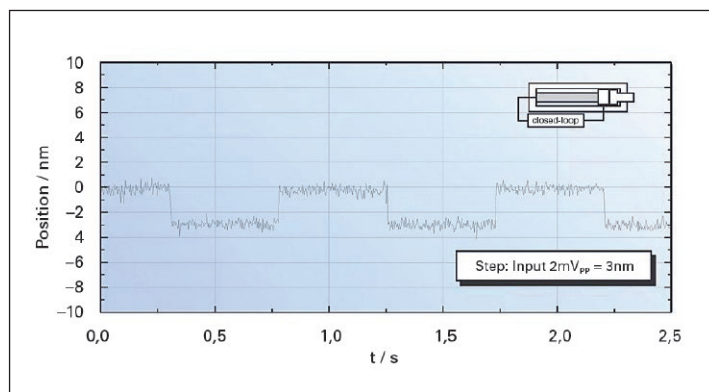

Response of a P-841.10 to a 3 nm peak-to-peak square wave control input signal, measured with servo-control bandwidth set to 240 Hz and 2 msec settling time.

P-842 Preloaded Piezo Actuators

For High Loads and Force Generation

P-842 / P-843, dimensions in mm. Max. torque on tip: 0.35 Nm.
Sensor only included with P-843.

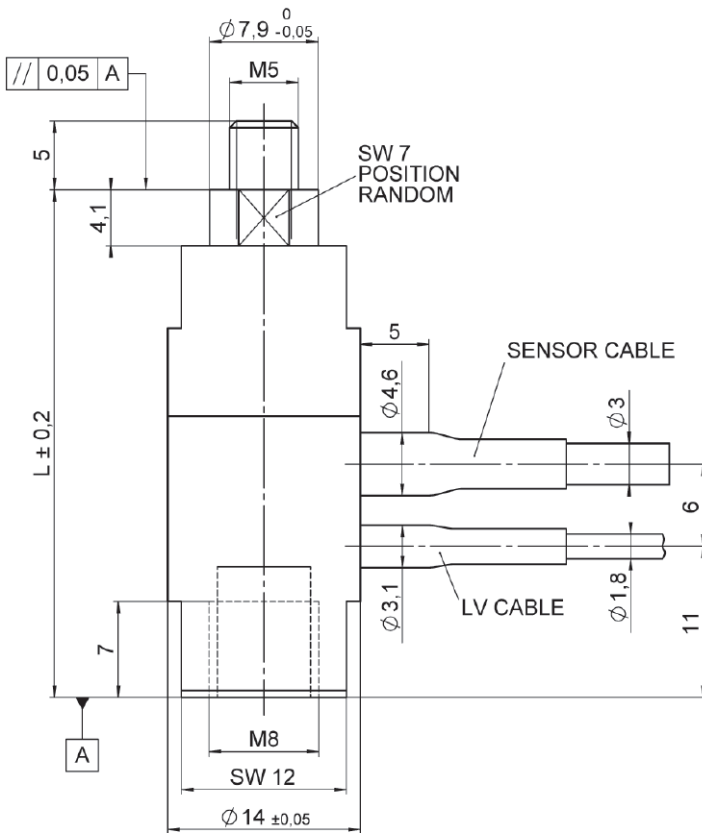

- Outstanding lifetime due to PICMA® piezo actuators
- Travel range to 90 µm
- Push forces to 800 N
- Pull forces to 300 N
- Microsecond response
- Subnanometer resolution
- Vacuum versions

Model	Travel range	L
P-842.10 / P-843.10	15 µm	37 mm
P-842.20 / P-843.20	30 µm	55 mm
P-842.30 / P-843.30	45 µm	73 mm
P-842.40 / P-843.40	60 µm	91 mm
P-842.60 / P-843.60	90 µm	127 mm

Actuators with position sensor available as P-843
Accessory P-176.50: Flexible Tips for P-842 / P-843

Applications

- Static and dynamic precision positioning
- Laser tuning
- Fiber positioning
- Nanotechnology

- >> PICMA® Multilayer Piezo Actuators
- >> Vacuum-Compatible Version

Technology Glossary page 240

	P-842.10	P-842.20	P-842.30	P-842.40	P-842.60	Unit	Tolerance
Travel range at 0 to 100 V	15	30	45	60	90	μm	±20 %
Resolution*	0.15	0.3	0.45	0.6	0.9	nm	
Static large-signal stiffness**	57	27	19	15	10	N/μm	±20 %
Push / pull force capacity	800 / 300	800 / 300	800 / 300	800 / 300	800 / 300	N	
Electrical capacitance	1.5	3	4.5	6	9	μF	±20 %
Resonant frequency f_0 (no load)	18	14	10	8.5	6	kHz	±20 %
Mass without cable	31	42	53	64	86	g	±5 %
Length	37	55	73	91	127	mm	
Recommended electronics	E-503, E-505, E-610, E-617, E-621, E-625, E-663, E-709, E-831	E-503, E-505, E-610, E-617, E-621, E-625, E-663, E-709, E-831	E-503, E-505, E-610, E-617, E-621, E-625, E-663, E-709, E-831	E-503, E-505, E-610, E-617, E-621, E-625, E-663, E-709, E-831	E-503, E-505, E-610, E-617, E-621, E-625, E-663, E-709, E-831	E-503, E-505, E-610, E-617, E-621, E-625, E-663, E-709, E-831	

Voltage connection: LEMO FFA.00.250. Coaxial cable RG 178, 1 m.

Temperature range: -40 to 80 °C.

Case / end pieces: Stainless steel.

Vacuum versions to 10⁻⁶ hPa are available under the following ordering number: P-842.x0V.

* The resolution of piezo actuators is not limited by stiction or friction. Value given is noise equivalent motion with E-503 amplifier.

** Dynamic small-signal stiffness is approx. 30 % higher.

All specifications based on room temperature (22 °C ±3 °C).

P-843 Preloaded Piezo Actuators

For High Loads and Force Generation with Integrated Position Sensors

P-842 / P-843, dimensions in mm. Max. torque on tip: 0.35 Nm.
Sensor only included with P-843.

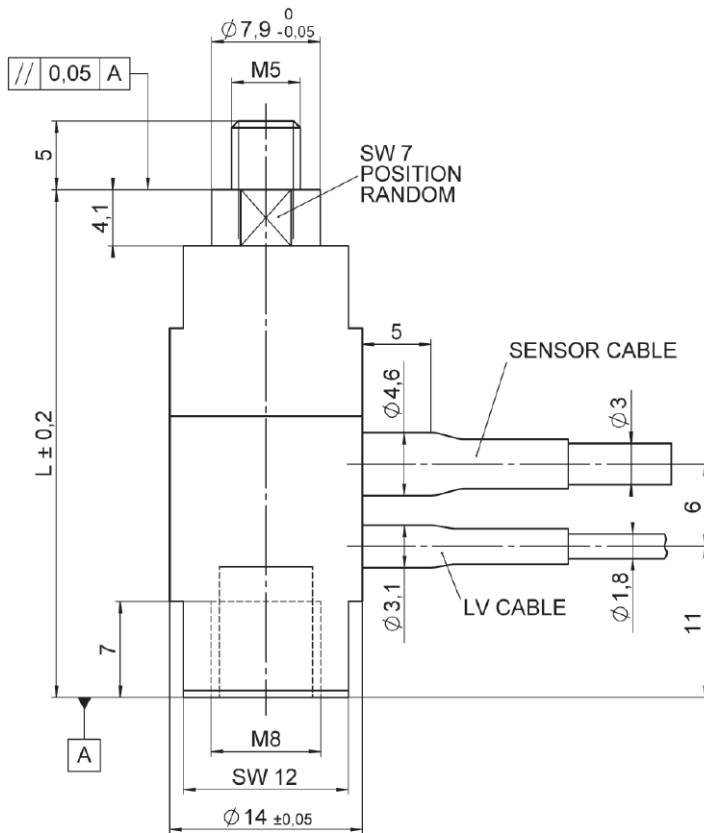

- Outstanding lifetime due to PICMA® piezo actuators
- Travel range to 90 µm
- Push forces to 800 N
- Pull forces to 300 N
- Microsecond response
- Subnanometer resolution
- Vacuum versions

Model	Travel range	L
P-842.10 / P-843.10	15 µm	37 mm
P-842.20 / P-843.20	30 µm	55 mm
P-842.30 / P-843.30	45 µm	73 mm
P-842.40 / P-843.40	60 µm	91 mm
P-842.60 / P-843.60	90 µm	127 mm

Accessory P-176.50: Flexible Tips for P-842 / P-843

Applications

- Static and dynamic precision positioning
- Laser tuning
- Fiber positioning
- Nanotechnology

- >> PICMA® Multilayer Piezo Actuators
- >> Vacuum-Compatible Version

Technology Glossary page 240

	P-843.10	P-843.20	P-843.30	P-843.40	P-843.60	Unit	Tolerance
Travel range at 0 to 100 V	15	30	45	60	90	μm	
Sensor*	SGS	SGS	SGS	SGS	SGS		
Resolution**	0.3	0.6	0.9	1.2	1.8	nm	
Static large-signal stiffness***	57	27	19	15	10	N/μm	±20 %
Push / pull force capacity	800 / 300	800 / 300	800 / 300	800 / 300	800 / 300	N	
Electrical capacitance	1.5	3	1.5	6	9	μF	±20 %
Resonant frequency f_0 (no load)	18	14	10	8.5	6	kHz	±20 %
Mass without cable	31	42	53	64	86	g	±5 %
Length	37	55	73	91	127	mm	
Recommended electronics	E-503, E-505, E-610, E-617, E-621, E-625, E-663, E-709, E-831	E-503, E-505, E-610, E-617, E-621, E-625, E-663, E-709, E-831	E-503, E-505, E-610, E-617, E-621, E-625, E-663, E-709, E-831	E-503, E-505, E-610, E-617, E-621, E-625, E-663, E-709, E-831	E-503, E-505, E-610, E-617, E-621, E-625, E-663, E-709, E-831		

Voltage connection: LEMO FFA.00.250. Coaxial cable, RG 178, 1 m.

Sensor connector: LEMO FFA.0S.304. Cable, 1 m.

Temperature range: -40 to 80 °C.

Case / end pieces: Stainless steel.

Vacuum versions to 10^{-5} hPa are available under the following ordering number: P-843.x0V.

* Models with SGS can attain linearity up to 0.15 % and are shipped with performance reports.

** The resolution of piezo actuators is not limited by stiction or friction. Value given is noise equivalent motion with E-503 amplifier.

*** Dynamic small-signal stiffness is approx. 30 % higher.

All specifications based on room temperature (22 °C ±3 °C).

P-844 Preloaded Piezo Actuators

For High Loads and Force Generation

- Outstanding lifetime due to PICMA® piezo actuators
- Travel range to 90 µm
- Push forces to 3000 N
- Pull forces to 700 N
- Microsecond response
- Subnanometer resolution
- Vacuum versions, optional water-resistant case



P-844 / P-845, dimensions in mm.
Max. torque on tip: 1 Nm.

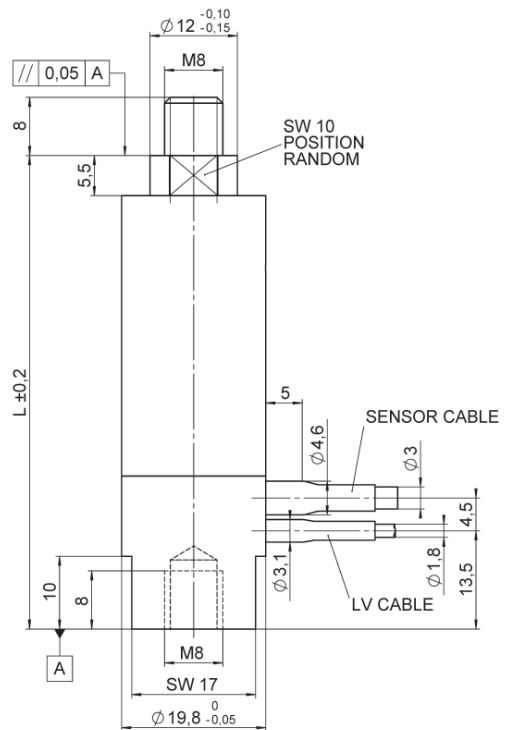

Model	Travel range	L
P-844.10 / P-845.10	15 µm	47 mm
P-844.20 / P-845.20	30 µm	65 mm
P-844.30 / P-845.30	45 µm	83 mm
P-844.40 / P-845.40	60 µm	101 mm
P-844.60 / P-845.60	90 µm	137 mm

Actuators with position sensor available under P-845
Accessory P-176.60: Flexible Tips for P-844 / P-845

Applications

- Static and dynamic precision positioning
- Laser tuning
- Fiber positioning
- Nanotechnology

- >> PICMA® Multilayer Piezo Actuators
- >> Vacuum-Compatible Version

Technology Glossary page 240

	P-844.10	P-844.20	P-844.30	P-844.40	P-844.60	Unit	Tolerance
Travel range at 0 to 100 V	15	30	45	60	90	μm	±20 %
Resolution*	0.15	0.3	0.45	0.6	0.9	nm	
Static large-signal stiffness**	225	107	75	57	38	N/μm	±20 %
Push / pull force capacity	3000 / 700	3000 / 700	3000 / 700	3000 / 700	3000 / 700	N	
Electrical capacitance	6	12	18	24	36	μF	±20 %
Resonant frequency f_0 (no load)	16	12	9	7.5	5.5	kHz	±20 %
Mass without cable	84	108	132	156	204	g	±5 %
Length L	47	65	83	101	137	mm	
Recommended electronics	E-503, E-505, E-610, E-617, E-621, E-625, E-663, E-709, E-831	E-503, E-505, E-610, E-617, E-621, E-625, E-663, E-709, E-831	E-503, E-505, E-610, E-617, E-621, E-625, E-663, E-709, E-831	E-503, E-505, E-610, E-617, E-621, E-625, E-663, E-709, E-831	E-503, E-505, E-610, E-617, E-621, E-625, E-663, E-709, E-831		

Voltage connection: LEMO FFA.00.250. Coaxial cable RG 178, 1 m.

Temperature range: -40 to 80 °C.

Case / end pieces: Stainless steel.

Vacuum versions to 10⁻⁶ hPa are available under the following ordering number: P-844.x0V.

* The resolution of piezo actuators is not limited by stiction or friction. Value given is noise equivalent motion with E-503 amplifier.

** Dynamic small-signal stiffness is approx. 30 % higher.

All specifications based on room temperature (22 °C ±3 °C).

P-845 Preloaded Piezo Actuators

For High Loads and Force Generation with Integrated Position Sensors

- Outstanding lifetime due to PICMA® piezo actuators
- Travel range to 90 µm
- Push forces to 3000 N
- Pull forces to 700 N
- Microsecond response
- Subnanometer resolution
- Vacuum versions, optional water-resistant case



P-844 / P-845, dimensions in mm.
Max. torque on tip: 1 Nm.

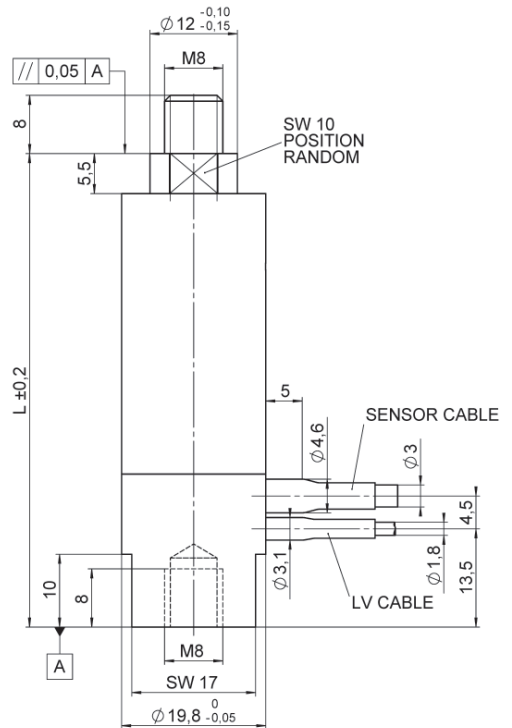

Model	Travel range	L
P-844.10 / P-845.10	15 µm	47 mm
P-844.20 / P-845.20	30 µm	65 mm
P-844.30 / P-845.30	45 µm	83 mm
P-844.40 / P-845.40	60 µm	101 mm
P-844.60 / P-845.60	90 µm	137 mm

Actuators without position sensor available under P-844
Accessory P-176.60: Flexible Tips for P-844 / P-845

Applications

- Static and dynamic precision positioning
- Laser tuning
- Fiber positioning
- Nanotechnology

- >> PICMA® Multilayer Piezo Actuators
- >> Vacuum-Compatible Version

Technology Glossary page 240

	P-845.10	P-845.20	P-845.30	P-845.40	P-845.60	Unit	Tolerance
Travel range at 0 to 100 V	15	30	45	60	90	μm	
Sensor*	SGS	SGS	SGS	SGS	SGS		
Resolution**	0.3	0.6	0.9	1.2	1.8	nm	
Static large-signal stiffness ***	225	107	75	57	38	N/μm	±20 %
Push / pull force capacity	3000 / 700	3000 / 700	3000 / 700	3000 / 700	3000 / 700	N	
Electrical capacitance	6	12	18	24	36	μF	±20 %
Resonant frequency f_0 (no load)	16	12	9	7.5	5.5	kHz	±20 %
Mass without cable	84	108	132	156	204	g	±5 %
Length L	47	65	83	101	137	mm	
Recommended electronics	E-503, E-505, E-610, E-617, E-621, E-625, E-663, E-709, E-831	E-503, E-505, E-610, E-617, E-621, E-625, E-663, E-709, E-831	E-503, E-505, E-610, E-617, E-621, E-625, E-663, E-709, E-831	E-503, E-505, E-610, E-617, E-621, E-625, E-663, E-709, E-831	E-503, E-505, E-610, E-617, E-621, E-625, E-663, E-709, E-831		

Voltage connection: LEMO FFA.00.250. Coaxial cable RG 178, 1 m.

Sensor connector: LEMO FFA.0S.304. Cable, 1 m.

Temperature range: -40 to 80 °C.

Case / end pieces: Stainless steel.

Vacuum versions to 10^{-5} hPa are available under the following ordering number: P-845.x0V.

* Models with SGS can attain linearity up to 0.15 % and are shipped with performance reports.

** The resolution of piezo actuators is not limited by stiction or friction. Value given is noise equivalent motion with E-503 amplifier.

*** Dynamic small-signal stiffness is approx. 30 % higher.

All specifications based on room temperature (22 °C ±3 °C).

Ask about custom designs!

P-853 / P-854 Piezoelectric Micrometer Drive

Integrated Piezo Drive with Sub-Nanometer Resolution

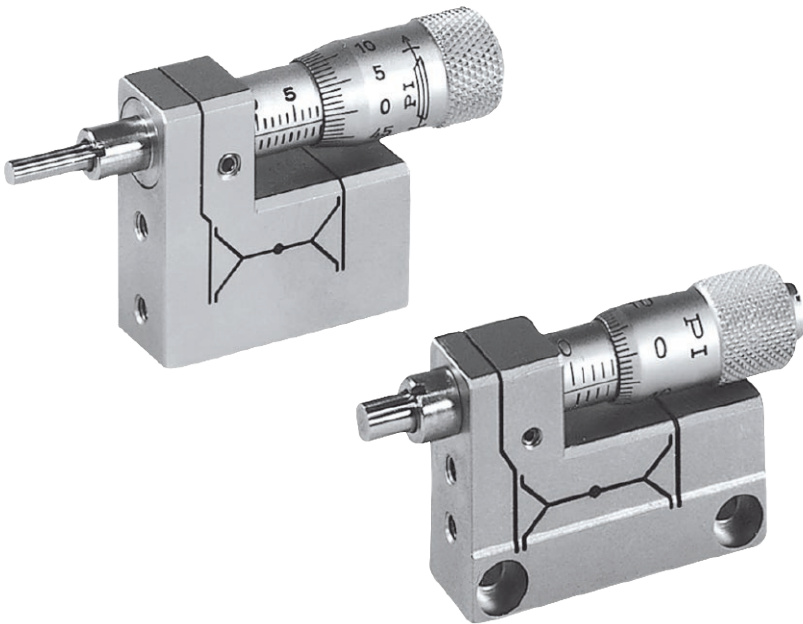

- Travel ranges to 18 mm
- Piezoelectric high-resolution travel to 25 μm
- Subnanometer resolution
- Dynamic operation to 10 Hz
- Alternative for standard micrometer drives

P-853, dimensions in mm.

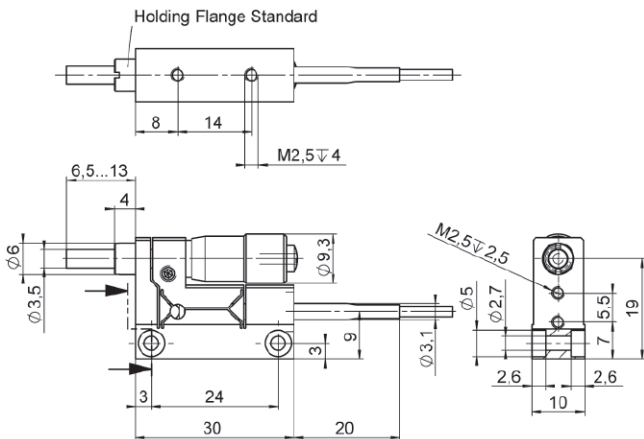

P-854, dimensions in mm.

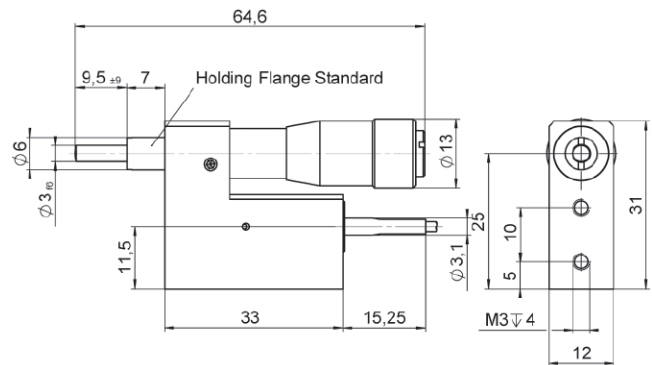

Applications

- Laboratory automation
- Autoadjust for optics

- >> Flexure Guiding Systems
- >> PICMA® Multilayer Piezo Actuators

Technology Glossary page 240

	P-853.00	P-854.00	Unit	Tolerance
Travel range (micrometer drive)	6	18	mm	
Piezo fine travel range, at 0 to 100 V	25	25	μm	
Min. incremental motion (piezo drive)	<1	<1	nm	
Micrometer sensitivity	1	1	μm	±20 %
Axial push / pull force	10 / 5	20 / 5	N	
Micrometer drive	M-619.10	M-626.10		±20 %
Micrometer pitch	0.5	0.5	mm/rev.	±20 %
Stiffness	1	1.5	N/μm	±5 %
Electrical capacitance (piezo)	0.45	1.5	μF	
Electrical connection	LEMO FFA.00.250, male. Coaxial cable: RG 178, Teflon coated, 1 m	LEMO FFA.00.250, male. Coaxial cable: RG 178, Teflon coated, 1 m		
Mass	0.05	0.1	kg	
Case material	N - S	N - S		
Recommended electronics	E-610, E-836	E-610, E-836		

All specifications based on room temperature (22 °C ±3 °C).
Ask about custom designs!

P-212 PICA Power Piezo Actuator

Preloaded Piezo Actuators (HVPZT) with Sensor Option



- Travel range to 120 μm
- Push forces to 2000 N
- Pull forces to 300 N
- Sub-ms response time
- Subnanometer resolution
- Options: Vacuum, high-temperature

P-212, dimensions in mm.

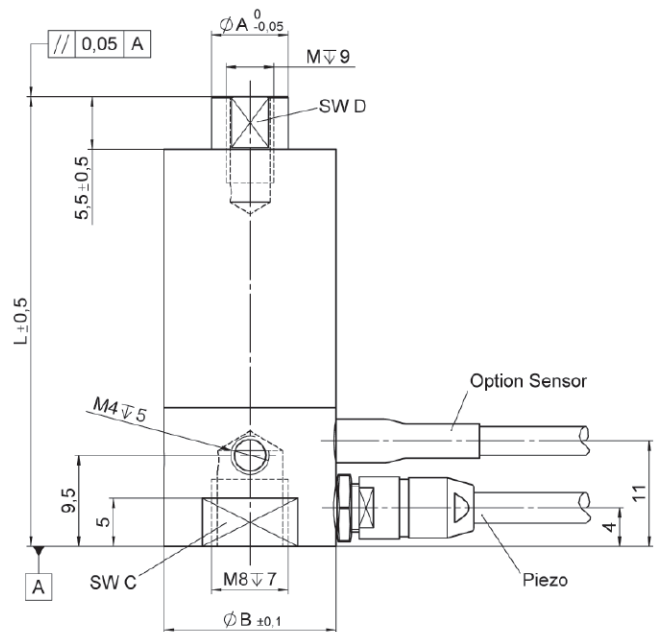

	L	A	B	C	D	M
P-212.1x	47	8	18	15	7	5
P-212.2x	60	8	18	15	7	5
P-212.4x	86	8	18	15	7	5
P-212.8x	139	8	18	15	7	5

Applications

- Active vibration damping
- Adaptive mechanics
- Precision engineering / micromechanics
- Optics
- Metrology / interferometry
- Adaptronics
- Switches Laser tuning
- Force generation / materials testing
- Nanotechnology

>> Vacuum-Compatible Version

Technology Glossary page 240

	P-212.10	P-212.20	P-212.40	P-212.80	Unit	Tolerance
Operating voltage	0 to 1000	0 to 1000	0 to 1000	0 to 1000	V	
Motion and positioning						
Closed-loop travel*	15	30	60	120	μm	
Closed-loop resolution*/**	0.3	0.6	1.2	2.4	nm	
Open-loop resolution**	0.15	0.3	0.6	1.2	nm	typ.
Linearity error*	0.2	0.2	0.2	0.2	%	typ.
Mechanical properties						
Static large-signal stiffness in motion direction***	90	60	34	18	N/μm	±20 %
Unloaded resonant frequency	17	12	7	4.5	kHz	±20 %
Push / pull force capacity in motion direction	2000 / 300	2000 / 300	2000 / 300	2000 / 300	N	max.
Shear load	15	10	10	10	N	max.
Torque on tip	0.5	0.5	0.5	0.5	Nm	max.
Drive properties						
Electrical capacitance	47	90	180	370	nF	±20 %
Miscellaneous						
Mass with cable	110	120	150	210	g	±5 %
Recommended electronics	E-462, E-464, E-470 / E-472 / E-421, E-481, E-482, E-508	E-462, E-464, E-470 / E-472 / E-421, E-481, E-482, E-508	E-462, E-464, E-470 / E-472 / E-421, E-481, E-482, E-508	E-462, E-464, E-470 / E-472 / E-421, E-481, E-482, E-508		

Piezo ceramic: PICA Power.

Temperature range: -40 to 80 °C.

The operating voltage should not exceed 750 V in continuous operation.

* Requires integrated strain gauge sensor. These versions are shipped with a performance report.

** The position resolution of piezo actuators is not limited by stiction or friction.

*** Dynamic small-signal stiffness is approx. 50 % higher.

All specifications based on room temperature (22 °C ±3 °C).

Accessories

P-176.B12 ball tip for P-212

P-176.F12 flat tip for P-212

P-176.10 magnetic adapter for P-212 translators

P-216 PICA Power Piezo Actuator

Preloaded Piezo Actuators (HVPZT) with Sensor Option



- Travel range to 180 μm
- Push forces to 4500 N
- Pull forces to 500 N
- Sub-ms response time
- Subnanometer resolution
- Options: Vacuum, high-temperature

P-216, dimensions in mm.

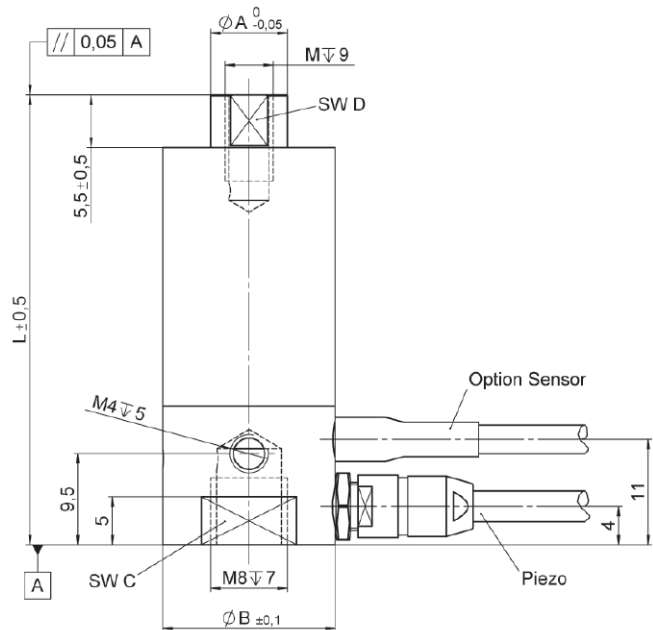

	L	A	B	C	D	M
P-216.1x	47	10	25	22	8	6
P-216.2x	60	10	25	22	8	6
P-216.4x	86	10	25	22	8	6
P-216.8x	139	10	25	22	8	6
P-216.9x	191	10	25	22	8	6

Applications

- Active vibration damping
- Adaptive mechanics
- Precision engineering / micromechanics
- Optics
- Metrology / interferometry
- Adaptronics
- Switches Laser tuning
- Force generation / materials testing
- Nanotechnology

>> Vacuum-Compatible Version

Technology Glossary page 240

	P-216.10	P-216.20	P-216.40	P-216.80	P-216.90	Unit	Tolerance
Operating voltage	0 to 1000	0 to 1000	0 to 1000	0 to 1000	0 to 1000	V	
Motion and positioning							
Closed-loop travel*	15	30	60	120	180	µm	
Closed-loop resolution*/**	0.3	0.6	1.2	2.4	3.6	nm	typ.
Open-loop resolution**	0.15	0.3	0.6	1.2	1.8	nm	typ.
Linearity error*	0.2	0.2	0.2	0.2	0.2	%	typ.
Mechanical properties							
Static large-signal stiffness in motion direction***	210	140	80	50	32	N/µm	±20 %
Unloaded resonant frequency	17	12	7	4.5	3	kHz	±20 %
Push / pull force capacity in motion direction	4500 / 500	4500 / 500	4500 / 500	4500 / 500	4500 / 500	N	max.
Shear load	60	36	23	23	23	N	max.
Torque on tip	1	1	1	1	1	Nm	max.
Drive properties							
Electrical capacitance	130	250	500	1000	1500	nF	±20 %
Miscellaneous							
Mass with cable	170	200	250	370	480	g	±5 %
Recommended electronics	E-462, E-464, E-470 / E-472 / E-421, E-481, E-482, E-508	E-462, E-464, E-470 / E-472 / E-421, E-481, E-482, E-508	E-462, E-464, E-470 / E-472 / E-421, E-481, E-482, E-508	E-462, E-464, E-470 / E-472 / E-421, E-481, E-482, E-508	E-462, E-464, E-470 / E-472 / E-421, E-481, E-482, E-508	E-462, E-464, E-470 / E-472 / E-421, E-481, E-482, E-508	

Piezo ceramic: PICA Power.

Temperature range: -40 to 80 °C.

The operating voltage should not exceed 750 V in continuous operation.

* Requires integrated strain gauge sensor. These versions are shipped with a performance report.

** The position resolution of piezo actuators is not limited by stiction or friction.

*** Dynamic small-signal stiffness is approx. 50 % higher.

All specifications based on room temperature (22 °C ±3 °C).

Accessories

P-176.B16 ball tip for P-216

P-176.F16 flat tip for P-216

P-225 PICA Power Piezo Actuators

Preloaded High-Load Piezo Actuators (HVPZT) with Sensor Option



- Extremely high stiffness
- Push forces to 12500 N
- Pull forces to 2000 N
- Travel range to 120 μm
- Options: Versions for vacuum, high temperatures and with water-resistant case

P-225, dimensions in mm.

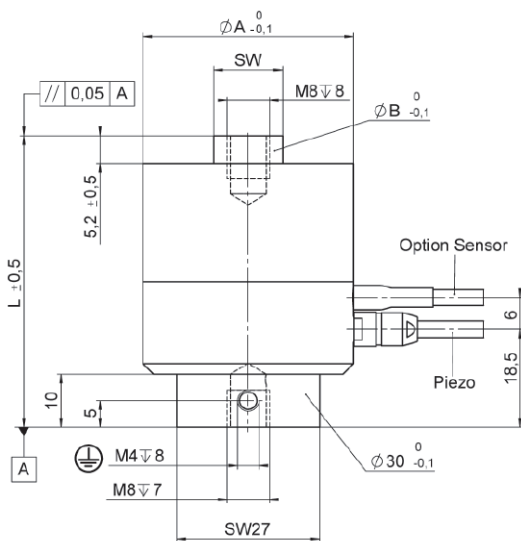

	L [mm]	∅ A [mm]	∅ B [mm]	SW
P-225.1x	55	39,8	16	13
P-225.2x	68	39,8	16	13
P-225.4x	94	39,8	16	13
P-225.8x	147	39,8	16	13

Applications

- Active vibration damping
- Adaptive mechanics
- Precision engineering / micromechanics
- Optics
- Metrology / interferometry
- Adaptronics
- Switches Laser tuning
- Force generation / materials testing
- Nanotechnology

>> Vacuum-Compatible Version

Technology Glossary page 240

	P-225.10	P-225.20	P-225.40	P-225.80	Unit	Tolerance
Operating voltage	0 to 1000	0 to 1000	0 to 1000	0 to 1000	V	
Motion and positioning						
Closed-loop travel*	15	30	60	120	μm	
Closed-loop resolution*	0.3	0.6	1.2	2.4	nm	typ.
Open-loop resolution**	0.15	0.3	0.6	1.2	nm	typ.
Linearity error	0.2	0.2	0.2	0.2	%	typ.
Mechanical properties						
Static large-signal stiffness in the direction of motion***	480	330	200	110	N/μm	±20 %
Unloaded resonant frequency	14	10	7	4	kHz	±20 %
Push / pull force capacity in motion direction	12500 / 2000	12500 / 2000	12500 / 2000	12500 / 2000	N	max.
Shear load	255	152	84	73	N	max.
Torque on tip	1.5	1.5	1.5	1.5	Nm	max.
Drive properties						
Electrical capacitance	320	630	1300	2600	nF	±20 %
Miscellaneous						
Mass (with cable)	410	470	610	900	g	±5 %
Recommended electronics	E-462, E-464, E-470 / E-472 / E-421, E-481, E-482, E-508	E-462, E-464, E-470 / E-472 / E-421, E-481, E-482, E-508	E-462, E-464, E-470 / E-472 / E-421, E-481, E-482, E-508	E-462, E-464, E-470 / E-472 / E-421, E-481, E-482, E-508	E-462, E-464, E-470 / E-472 / E-421, E-481, E-482, E-508	

Piezo ceramic: PICA Power

Temperature range: -40 to 80 °C

The operating voltage should not exceed 750 V in continuous operation.

* Requires integrated strain gauge sensor. These versions are shipped with a performance report.

** Measured interferometrically. The position resolution of piezo actuators is not limited by stiction or friction.

*** Dynamic small-signal stiffness is approx. 50 % higher.

All specifications based on room temperature (22 °C ±3 °C).

The specifications of vacuum versions can differ. Ask about custom designs!

Accessories

P-176.B25 ball tip for P-225 and P-235

P-176.F35 flat tip for P-235

P-235 PICA Power Piezo Actuators

Preloaded High-Load Piezo Actuators (HVPZT) with Sensor Option



- Extremely high stiffness
- Push forces to 30000 N
- Pull forces to 3500 N
- Travel range to 180 μm
- Options: Versions for vacuum, high temperatures and with water-resistant case

P-235, dimensions in mm.

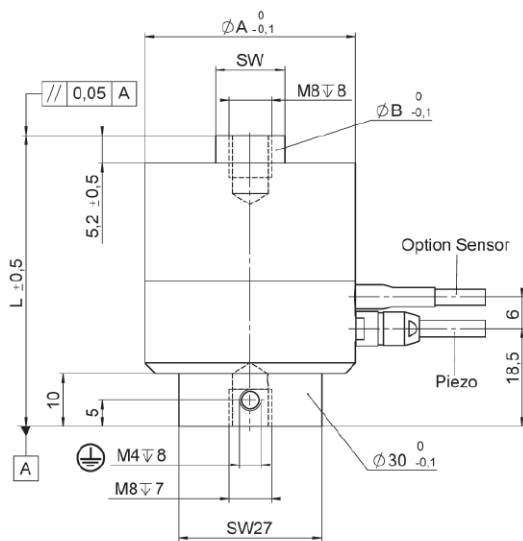

	L [mm]	Ø A [mm]	Ø B [mm]	SW
P-235.1x	55	49,8	20	17
P-235.2x	68	49,8	20	17
P-235.4x	94	49,8	20	17
P-235.8x	147	49,8	20	17
P-235.9x	199	49,8	20	17

Applications

- Active vibration damping
- Adaptive mechanics
- Precision engineering / micromechanics
- Optics
- Metrology / interferometry
- Adaptronics
- Switches Laser tuning
- Force generation / materials testing
- Nanotechnology

>> Vacuum-Compatible Version

Technology Glossary page 240

	P-235.10	P-235.20	P-235.40	P-235.80	P-235.90	Unit	Tolerance
Operating voltage	0 to 1000	0 to 1000	0 to 1000	0 to 1000	0 to 1000	V	
Motion and positioning							
Closed-loop travel*	15	30	60	120	180	µm	
Closed-loop resolution*	0.3	0.6	1.2	2.4	3.6	nm	typ.
Open-loop resolution**	0.15	0.3	0.6	1.2	1.8	nm	typ.
Linearity error	0.2	0.2	0.2	0.2	0.2	%	typ.
Mechanical properties							
Static large-signal stiffness in the direction of motion***	860	600	380	210	150	N/µm	±20 %
Unloaded resonant frequency	14	10	7	4	2.8	kHz	±20 %
Push / pull force capacity in motion direction	30000 / 3500	30000 / 3500	30000 / 3500	30000 / 3500	30000 / 3500	N	max.
Shear load	707	420	232	147	147	N	max.
Torque on tip	2	2	2	2	2	Nm	max.
Drive properties							
Electrical capacitance	550	1100	2400	5100	7800	nF	±20 %
Miscellaneous							
Mass (with cable)	580	690	940	1400	1900	g	±5 %
Recommended electronics	E-462, E-464, E-470 / E-472 / E-421, E-481, E-482, E-508	E-462, E-464, E-470 / E-472 / E-421, E-481, E-482, E-508	E-462, E-464, E-470 / E-472 / E-421, E-481, E-482, E-508	E-462, E-464, E-470 / E-472 / E-421, E-481, E-482, E-508	E-462, E-464, E-470 / E-472 / E-421, E-481, E-482, E-508	E-462, E-464, E-470 / E-472 / E-421, E-481, E-482, E-508	

Piezo ceramic: PICA Power

Temperature range: -40 to 80 °C

The operating voltage should not exceed 750 V in continuous operation.

* Requires integrated strain gauge sensor. These versions are shipped with a performance report.

** Measured interferometrically. The position resolution of piezo actuators is not limited by stiction or friction.

*** Dynamic small-signal stiffness is approx. 50 % higher.

All specifications based on room temperature (22 °C ±3 °C).

The specifications of vacuum versions can differ. Ask about custom designs!

Accessories

P-176.B25 ball tip for P-225 and P-235

P-176.F35 flat tip for P-235

P-286 / P-288 / P-289 Disk Translators

Bimorph Piezo Actuators with High Dynamics



- Travel range to 200 μm
- Sub-nm resolution
- Sub-ms response time
- Cost-efficient
- Low profile

P-286, dimensions in mm.

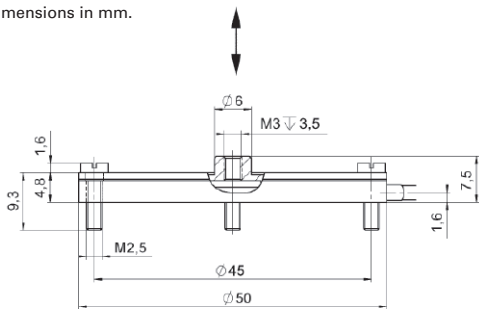

P-289, dimensions in mm.

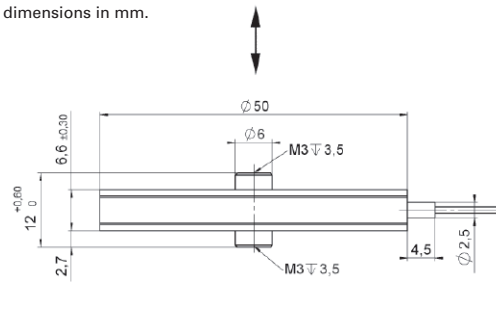

Applications

- Active vibration damping
- Adaptive mechanics
- Precision engineering / micromechanics
- Optics
- Metrology / interferometry
- Adaptronics
- Switches Laser tuning
- Force generation / materials testing
- Nanotechnology

Technology Glossary page 240

	P-286.xx	P-288.00	P-289.20	Unit	Tolerance
Travel at 0 to -750 V (P-288), 0 to -1000 V (P-286, P-289)	100	50	200	μm	±20 %
Resolution*	1.0	0.5	2.0	nm	
Static large-signal stiffness**	0.3	0.2	0.15	N/μm	±20 %
Push / pull force capacity	20 / 10	10 / 5	20 / 10	N	
Max. torque limit (on tip)	0.003	0.003	0.003	Nm	
Max. operating voltage	-1000	-750	-1000	V	
Electrical capacitance	65	9	130	nF	±20 %
Unloaded resonant frequency f_0	2.5	2	1.1	kHz	±20 %
Operating temperature	-40 to +80	-40 to +80	-40 to +80	°C	
Voltage connection	Stranded wires (PTFE-insulated)	Stranded wires (PTFE-insulated)	Stranded wires (PTFE-insulated)		
Mass	42	8	56	g	±5 %
Material: case, end pieces	Stainless steel	Brass	Stainless steel		

* Resolution of piezo actuators is not limited by friction or stiction. Noise equivalent motion with E-507 amplifier.

** Dynamic small-signal stiffness ~50 % higher.

All specifications based on room temperature (22 °C ±3 °C).

P-288, dimensions in mm.

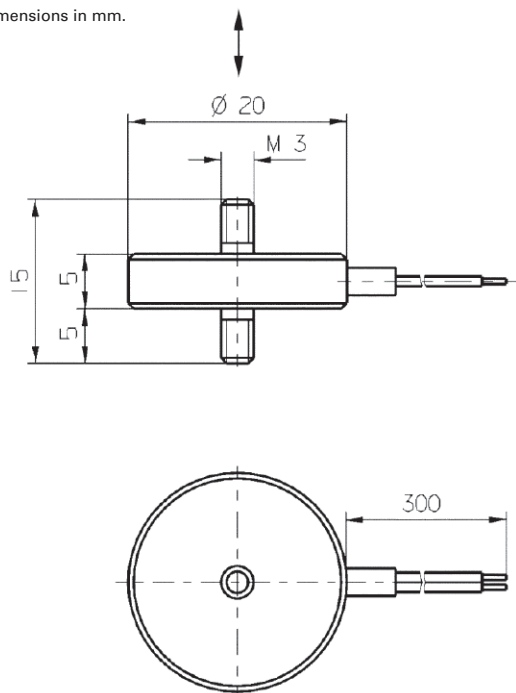

P-871 PICMA® Multilayer Bending Actuators

With Position Sensor

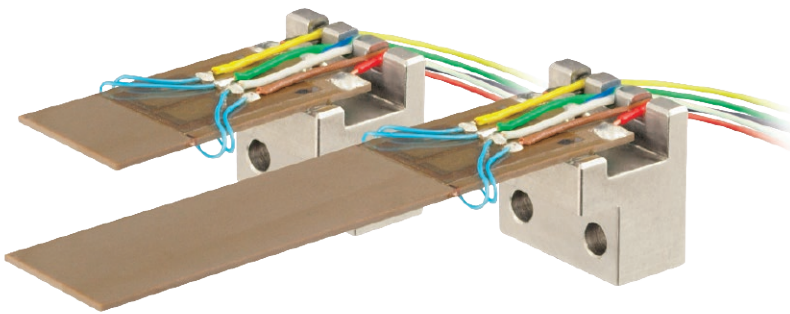

- Closed-loop operation for superior accuracy
- Nanometer resolution
- Displacement to 1.6 mm
- Ceramic encapsulation for extended lifetime
- Ideal for scanning applications
- Vacuum-compatible versions
- Low operating voltage
- Mounting hardware included
- Special OEM- and bench-top amplifiers available

P-871, dimensions in mm.

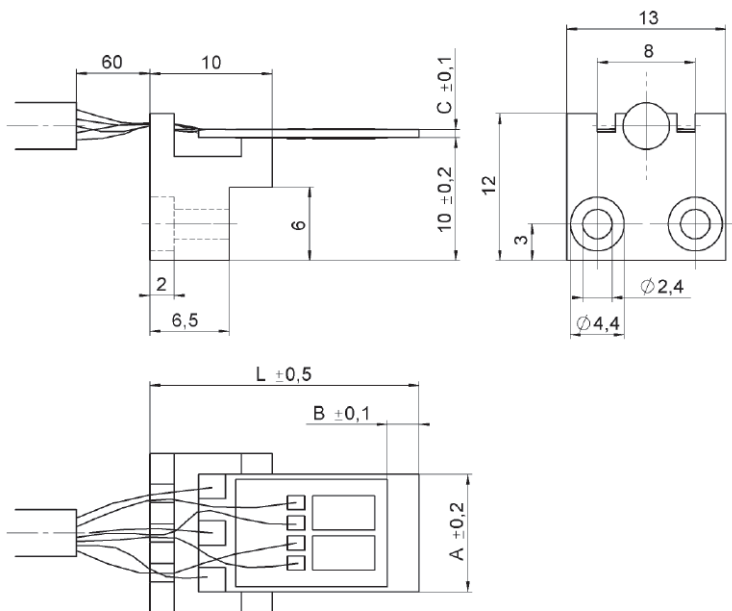

	L	A	B	C
P-871.112	22	9,6	2,6	0,65
P-871.122	29	9,6	9,6	0,65
P-871.127	35	9,6	15,6	0,65
P-871.128	40	6,25	17	0,75
P-871.140	49	11	29,1	0,60

Applications

- Wire bonders
- Pneumatic valves
- Fiber optic positioning & switches
- (Laser)-Beam steering
- Micromanipulation
- Micropositioning
- Nanotechnology

>> PICMA® Multilayer Piezo Actuators

Technology Glossary page 240

	P-871.112	P-871.122	P-871.127	P-871.128	P-871.140	Unit	Tolerance
Operating voltage	0 to 60 (±30)	0 to 60 (±30)	0 to 60 (±30)	0 to 60 (±30)	0 to 60 (±30)	V	
Closed-loop travel	±80	±200	±360	±360	±800	µm	
Integrated feedback sensor	SGS	SGS	SGS	SGS	SGS		
Closed-loop linearity error	0.5	0.5	0.5	0.5	0.5	%	
Static large-signal stiffness	0.02	0.01	0.003	0.002	0.0007	N/µm	
Blocking force	±2.0	±1.1	±1.0	±0.5	±0.5	N	±20 %
Electrical capacitance*	2 × 1.1	2 × 2.4	2 × 3.4	2 × 1.2	2 × 4.0	µF	±20 %
Unloaded resonant frequency**	2540	1010	560	340	195	Hz	±20 %
Resonant frequency at 6.5 g	480	220	145	100	60	Hz	±20 %
Operating temperature range	-20 to 150	-20 to 85	-20 to 85	-20 to 150	-20 to 85	°C	
Cable length	>1	>1	>1	>1	>1	m	
Sensor and voltage connection	LEMO	LEMO	LEMO	LEMO	LEMO		
Recommended electronics	E-651 / E-614	E-651 / E-614	E-651 / E-614	E-651 / E-614	E-651 / E-614		

* Electrical capacitance: Measured at 1 V_{pp}, 1 kHz, RT, tolerance ±20 %.

** Resonant frequency: Measured at 1 V_{pp}, unloaded.

All specifications depend on actual clamping conditions and mechanical load applied.

All specifications based on room temperature (22 °C ±3 °C).

Custom designs or different specifications on request.

PiezoWalk OEM Piezomotors and Controllers

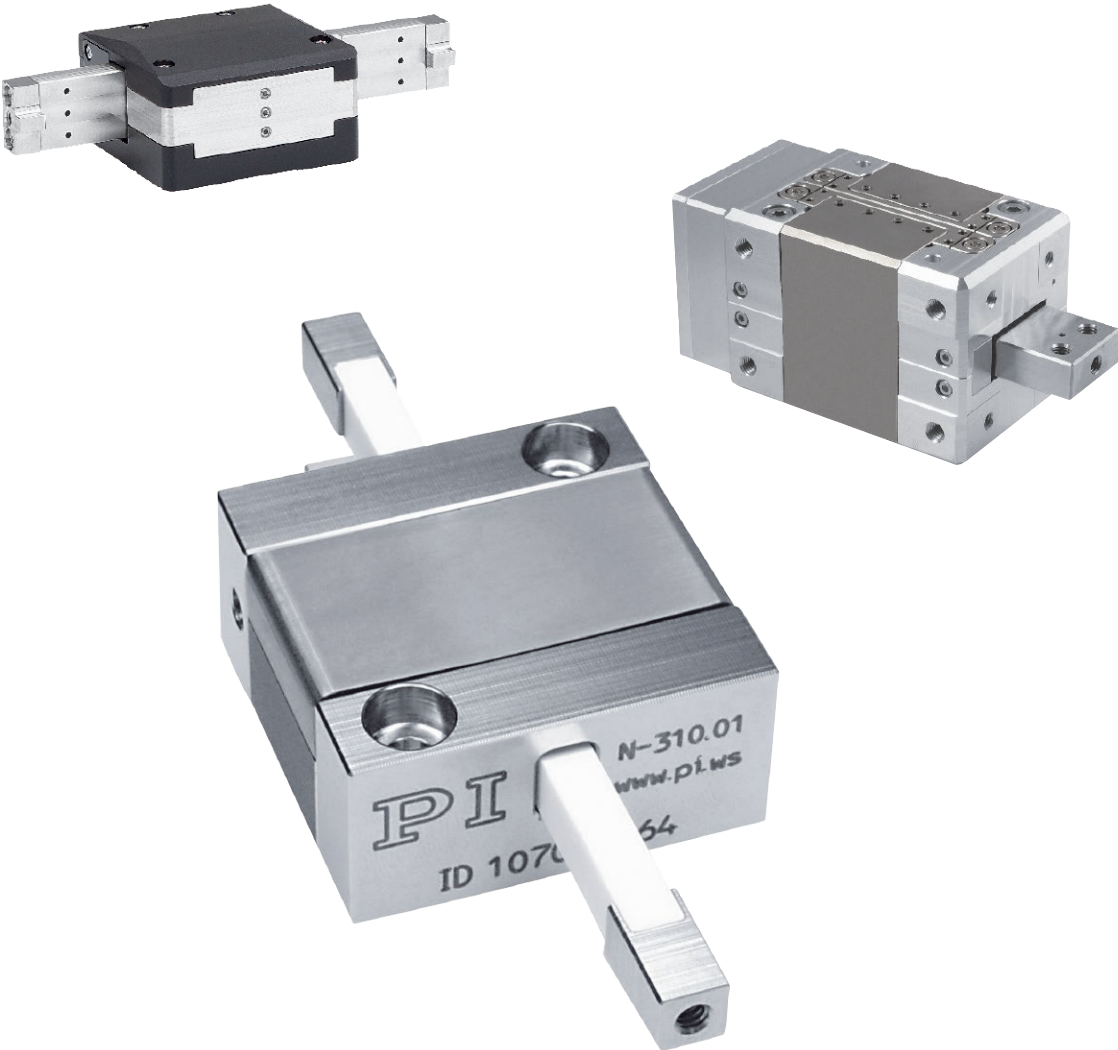

OEM Actuators	158
N-331 PICMAWalk Walking Drive	160
N-216 NEXLINE® Linear Actuator	162
N-111 NEXLINE® OEM Linear Actuator	164
N-310 NEXACT® OEM Miniature Linear Motor / Actuator	166
N-381 NEXACT® Linear Actuator, Manipulator, Piezo Stepper	168

PiezoWalk Controllers	170
E-712.1AN / E-712.2AN / E-712.3AN PICMAWalk Digital Controller	170
E-712.1AM Digital Motion Controller	172
E-861 PiezoWalk® NEXACT® Controller / Driver	174
E-862 NEXACT® Drive Electronics	176

N-331 PICMAWalk Walking Drive

OEM Walking Drive for Durable Applications with up to 15 mm/s Velocity and up to 50 N Push/Pull Force



- Robust walking drive with PICMA® technology and extreme durability for industrial use
- Fastest and strongest drive of its size class
- Variable runner lengths from 25 mm to 100 mm
- Precise, nanometer precision positioning of loads up to 5 kg
- Plug-and-play, thanks to PI proprietary controller technology

N-331.x3, dimensions in mm.
Dimensions for the N-331.x0 are identical.

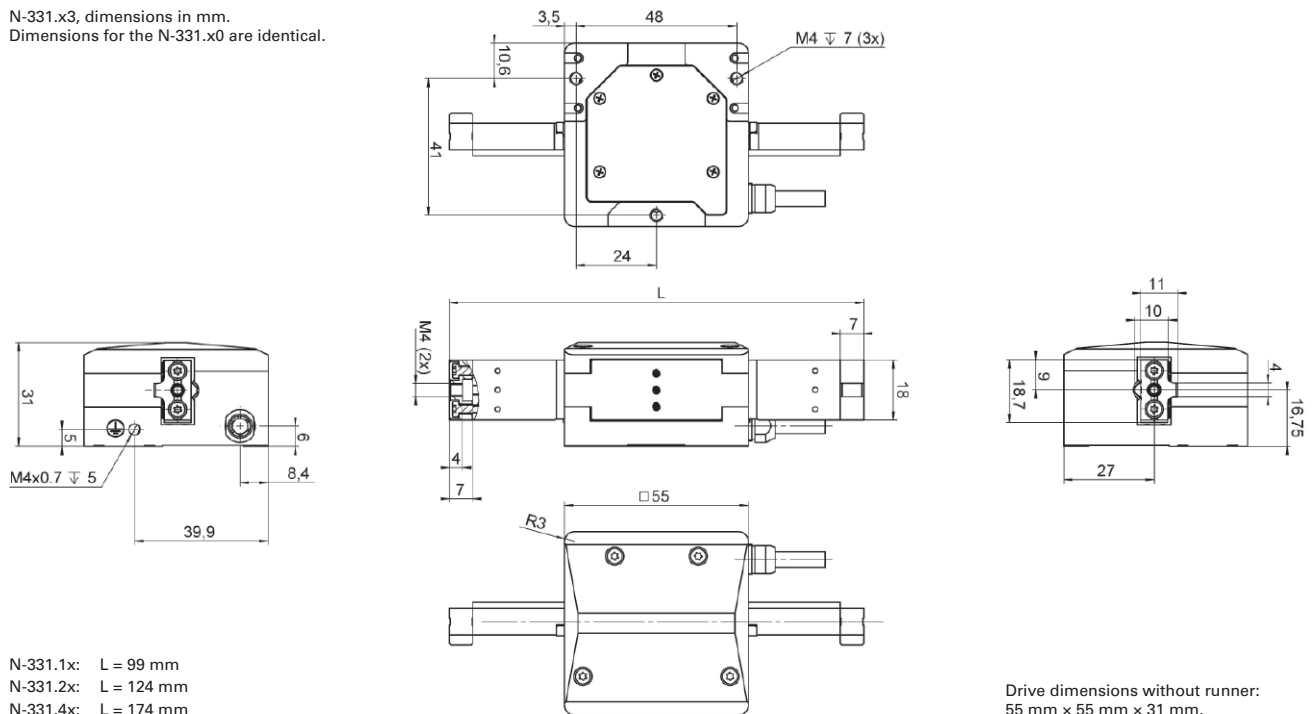

- N-331.1x: L = 99 mm
- N-331.2x: L = 124 mm
- N-331.4x: L = 174 mm

Applications

- Industrial precision motion
- Semiconductor technology
- Semiconductor testing
- Wafer inspection
- Lithography
- Nano imprint
- Nanometrology
- Motion in strong magnetic fields and vacuum

- >> Incremental Encoder
- >> PiezoWalk® Walking Drive
- >> PICMA® Multilayer Piezo Actuators
- >> Vacuum-Compatible Version

Technology Glossary page 240

	N-331.10 / N-331.13 N-331.20 / N-331.23 N-331.40 / N-331.43	Unit	Tolerance
Active axes	X		
Motion and positioning			
Integrated sensor	N-331.x0: Without sensor N-331.x3: With incremental sensor		
Travel range (step mode, open loop)*	N-331.1x: 30 N-331.2x: 55 N-331.4x: 105	mm	±0.5 mm
Travel range (step mode, closed loop)	N-331.1x: 25 N-331.2x: 50 N-331.4x: 100	mm	
Step frequency**	600	Hz	max.
Velocity (step mode)**	15	mm/s	max.
Travel range (analog mode)	±10	µm	typ.
Resolution (open loop)	0.02	nm	typ.
Resolution (closed loop)	<10 (N-331.x3)	nm	typ.
Endurance (atmospherical operation)***	>30	km	
Mechanical properties			
Push / pull force (active)	50	N	max.
Holding force (passive)	60	N	max.
Drive properties			
Drive type	PICMAWalk		
Operating voltage	-20 to 120	V	
Connectors			
Connector	Sub-D 37 (m)		
Miscellaneous			
Operating temperature range	0 to 50	°C	
Material	Aluminum, stainless steel		
Mass with cable	N-331.1x: 580 N-331.2x: 610 N-331.4x: 660	g	
Moved Mass	N-331.1x: 580 N-331.2x: 610 N-331.4x: 660	g	±10 g
Cable length	2.0	m	±10 mm
Recommended electronics	E-712.1AN / E-712.2AN / E 712.3AN		

* From one mechanical hard stop of the runner to the other mechanical hard stop, only in open-loop operation.

** When operating with the E-712.xAN.

*** At an optimally decoupled load of 2 kg with max. 70 % duty cycle and external cooling of the E-712.1AN, at 20 °C and 1013 hPa.
Highest endurance within the PiezoWalk® family.

All specifications based on room temperature (22 °C ±3 °C).

Ask about custom designs!

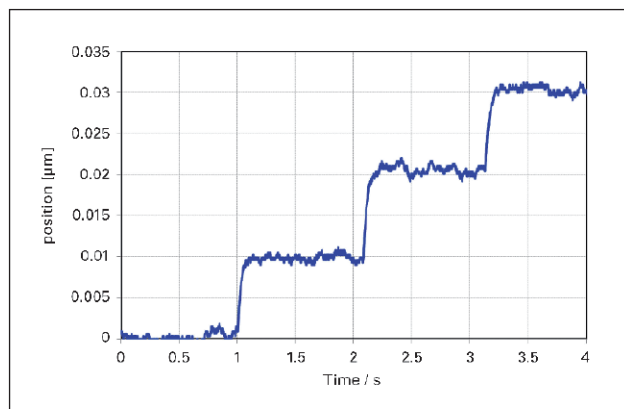

The N-331 drive reliably performs repeatable 10-nm steps.
An interferometer was used for measuring.

N-216 NEXLINE[®] Linear Actuator

High-Force PiezoWalk[®] Drive for Long-Range Nanopositioning

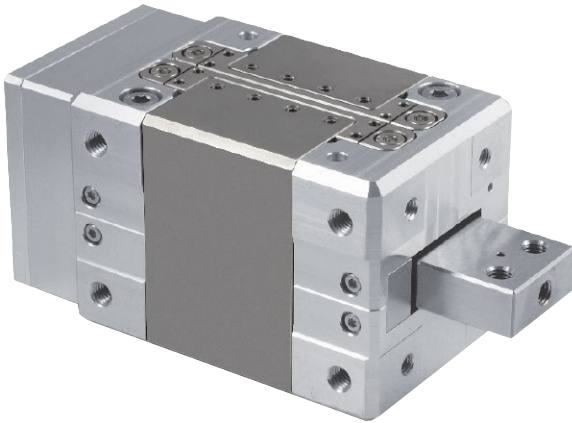

- Force generation up to 600 N
- Holding force up to 800 N
- Travel range 20 mm
- Integrated linear encoder with resolution 5 nm

N-216, dimensions in mm. Mounting flanges for side or front mounting are included in the delivery.

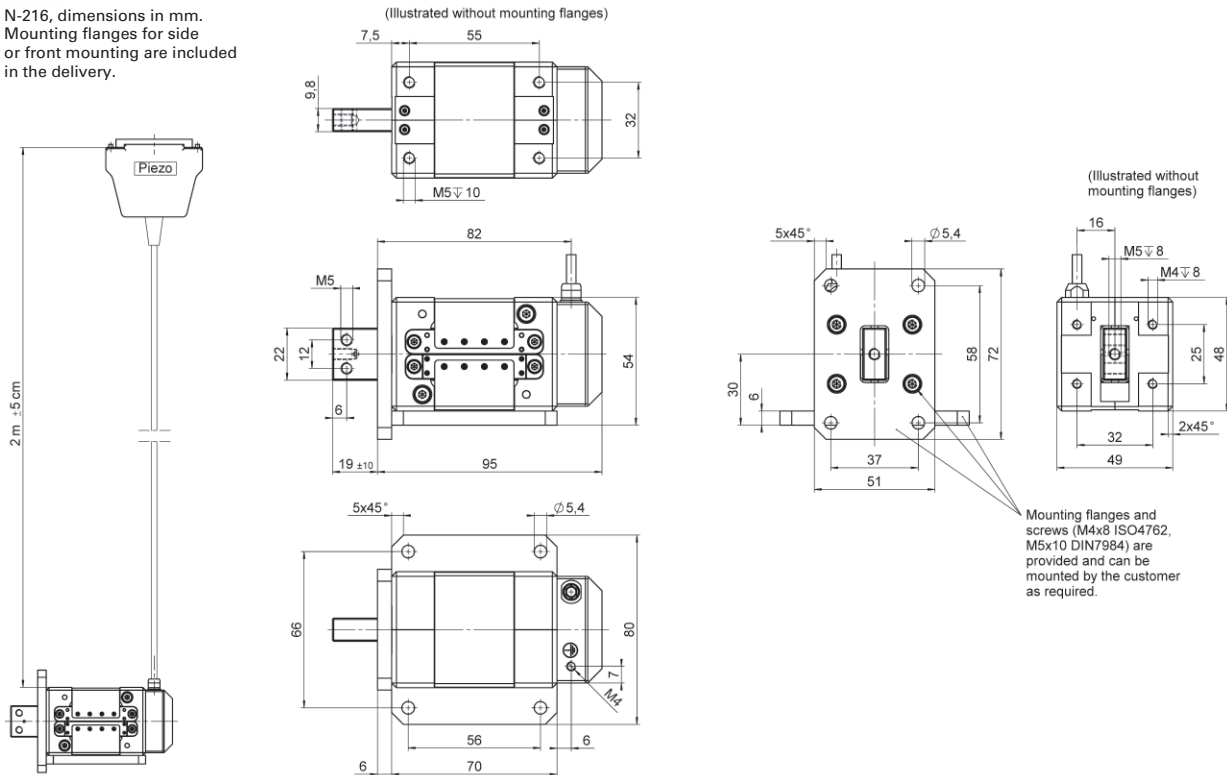

Applications

- Industrial precision motion
- Semiconductor technology
- Semiconductor testing
- Wafer inspection
- Lithography
- Nano imprint
- Nanometrology
- Motion in strong magnetic fields and vacuum

- >> Incremental Encoder
- >> PiezoWalk[®] Walking Drive
- >> Vacuum-Compatible Version

Technology Glossary page 240

	N-216.101 / N-216.1A1	N-216.201 / N-216.2A1	Tolerance
Active axes	X	X	
Motion and positioning			
Travel range	20 mm	20 mm	
Travel range in analog mode	±3 µm	±3 µm	
Integrated sensor	N-216.101: none N-216.1A1: linear encoder	N-216.201: none N-216.2A1: linear encoder	
Open-loop resolution	0.03 nm	0.03 nm	typ.
Closed-loop resolution	- / 5 nm (N-216.1A1)	- / 5 nm (N-216.2A1)	
Velocity (10 % duty cycle, full step mode)*	1.0 mm/s	1.0 mm/s	max.
Velocity (100 % duty cycle, full step mode)*	0.6 mm/s	0.6 mm/s	max.
Velocity (100 % duty cycle, nanostepping mode)**	0.4 mm/s	0.4 mm/s	max.
Mechanical properties			
Drive force (active)***	300 N	600 N	max.
Holding force (passive)	400 N	800 N	min.
Drive properties			
Motor type	NEXLINE®	NEXLINE®	
Operating voltage	-250 V to +250 V	-250 V to +250 V	
Miscellaneous			
Operating temperature range	0 to 55 °C	0 to 55 °C	
Material	Aluminum, stainless steel	Aluminum, stainless steel	
Mass	1150 g	1250 g	
Cable length	2.0 m	2.0 m	
Connector	Sub-D 25 (m)	Sub-D 25 (m)	
Recommended electronics	E-712.1AM	E-712.1AM	
Connector	Sub-D 25 (m)	Sub-D 25 (m)	
Recommended electronics	E-712.1AM	E-712.1AM	

* Depending on drive electronics. Data refer to operation together with E-712 controller.

** Depending on drive electronics. Data refer to operation together with E-712 controller. The maximum velocity in nanostepping mode is designed for the best possible constancy so that no velocity variations occur when executing the steps.

*** Data refer to full step mode operation.

All specifications based on room temperature (22 °C ±3 °C).

Ask about custom designs!

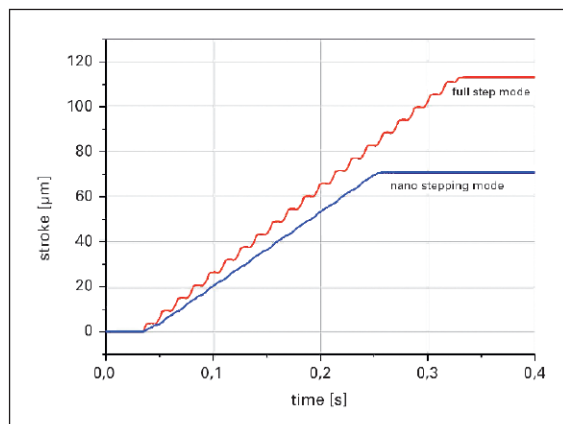

Motion mode comparison of a NEXLINE® actuator: The nanostepping mode provides a very smooth motion. Full step mode allows higher speed.

N-111 NEXLINE® OEM Linear Actuator

Nanopositioning Over Long Travel, PiezoWalk® Principle



- Travel range 10 mm
- Integrated linear encoder with resolution 5 nm
- Force generation to 50 N
- Holding force to 70 N

N-111.20, dimensions in mm.

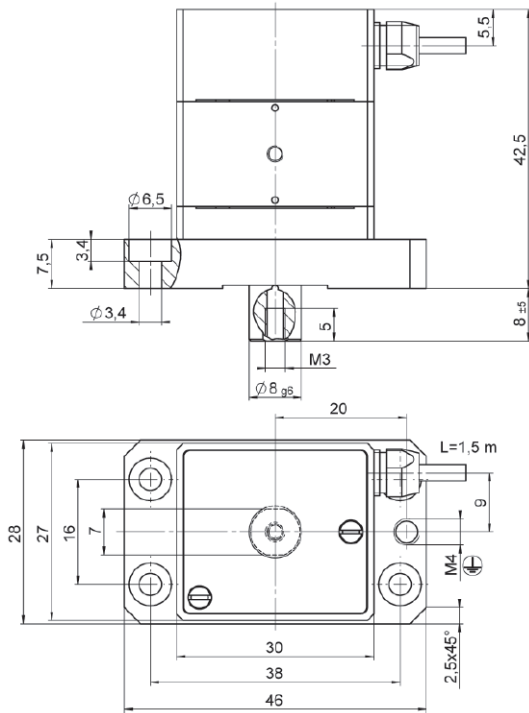

N-111.2A, dimensions in mm.

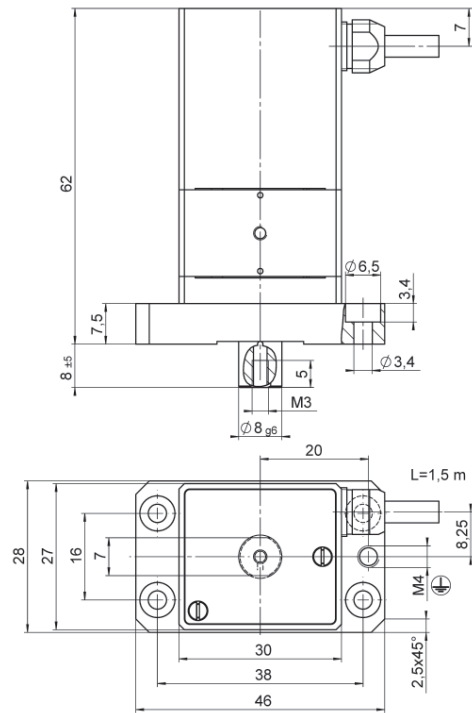

Applications

- Industrial precision motion
- Semiconductor technology
- Semiconductor testing
- Wafer inspection
- Lithography
- Nano imprint
- Nanometrology
- Motion in strong magnetic fields and vacuum

- >> Incremental Encoder
- >> PiezoWalk® Walking Drive
- >> Vacuum-Compatible Version

Technology Glossary page 240

	N-111.201	N-111.2A1	Unit	Tolerance
Active axes	X	X		
Motion and positioning				
Travel range	10	10	mm	
Travel range in analog mode	±2	±2	µm	
Integrated sensor	–	Linear encoder		
Open-loop resolution	0.025	0.025	nm	typ.
Closed-loop resolution	–	5 nm		
Velocity (10 % duty cycle, full step mode)*	1.0	1.0	mm/s	max.
Velocity (100 % duty cycle, full step mode)*	0.6	0.6	mm/s	max.
Velocity (100 % duty cycle, nanostepping mode)**	0.4	0.4	mm/s	max.
Mechanical properties				
Drive force (active)***	50	50	N	max.
Holding force (passive)	70	70	N	min.
Drive properties				
Motor type	NEXLINE®	NEXLINE®		
Operating voltage	±250	±250	V	
Miscellaneous				
Operating temperature range	0 to 55	0 to 55	°C	
Material	Aluminum, stainless steel, titanium	Aluminum, stainless steel, titanium		
Mass	245	325	g	
Cable length	1.5	1.5	m	±10 mm
Connector	Sub-D 25 (m)	Sub-D 25 (m)		
Recommended electronics	E-712.1AM	E-712.1AM		

* Depending on drive electronics. Data refer to operation with E-712 controller.

** Depending on drive electronics. Data refer to operation with E-712 controller. The maximum velocity in nanostepping mode is designed for the best possible constancy so that no velocity variations occur when executing the steps.

*** Data refer to operation in full step mode.

All specifications based on room temperature (22 °C ±3 °C).

Ask about custom designs!

N-310 NEXACT® OEM Miniature Linear Motor/Actuator

Compact, High-Speed PiezoWalk® Drive

- 20 to 125 mm travel range, flexible choice of the runner length
- Compact design, cost-effective design
- Resolution to 0.03 nm
- Force generation up to 10 N



N-310, dimensions in mm; runner length L = travel range + 40 mm.

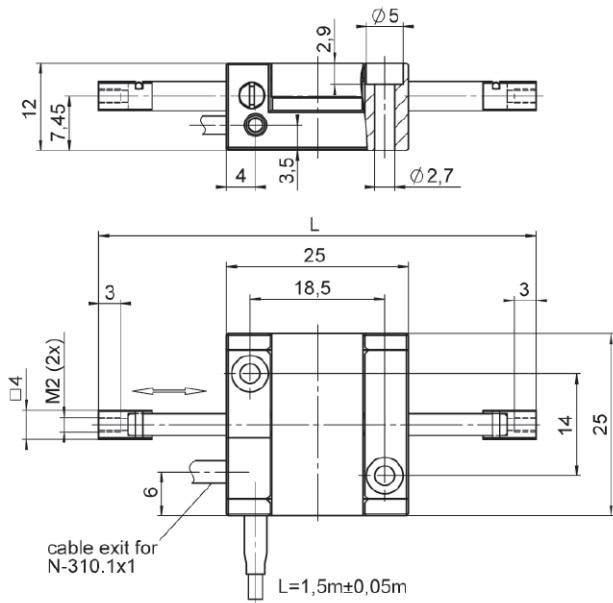

	L
N-310.10 / .101	50
N-310.11 / .111	60
N-310.12 / .121	70
N-310.13 / .131	90
N-310.14 / .141	115
N-310.15 / .151	140
N-310.16 / .161	165

Applications

- Industrial precision motion
- Semiconductor technology
- Semiconductor testing
- Wafer inspection
- Lithography
- Nano imprint
- Nanometrology
- Motion in strong magnetic fields and vacuum

- >> Incremental Encoder
- >> PiezoWalk® Walking Drive
- >> Vacuum-Compatible Version

Technology Glossary page 240

	N-310	Tolerance	
Active axes	X		
Motion and positioning			
Travel range	N-310.10: 10 mm N-310.11: 20 mm N-310.12: 30 mm N-310.13: 50 mm N-310.14: 75 mm N-310.15: 100 mm N-310.16: 125 mm		
Step size (in step mode)	5 nm to 5 µm		
Travel range in analog mode	±5 µm	max.	
Open-loop resolution	0.03 nm*	typ.	
Velocity	10 mm/s**	max.	
Mechanical properties			
Push / pull force (active)	10 N	max.	
Drive properties			
Drive type	NEXACT® linear drive		
Operating voltage	-10 V to +45 V		
Miscellaneous			
Operating temperature range	0 to 50 °C		
Casing material	Stainless steel		
Mass	50 g (20 mm travel range)	±5 %	
Cable length	1.5 m	±10 mm	
Connector	HD Sub-D 15 (m)		
Recommended electronics	E-712.1AM, E-861		

* Depending on drive electronics. 1 nm with E-861.

** Depending on drive electronics.

All specifications based on room temperature (22 °C ±3 °C).

Ask about custom designs!

N-381 NEXACT® Linear Actuator, Manipulator, Piezo Stepper

High-Resolution with Optional Position Sensor

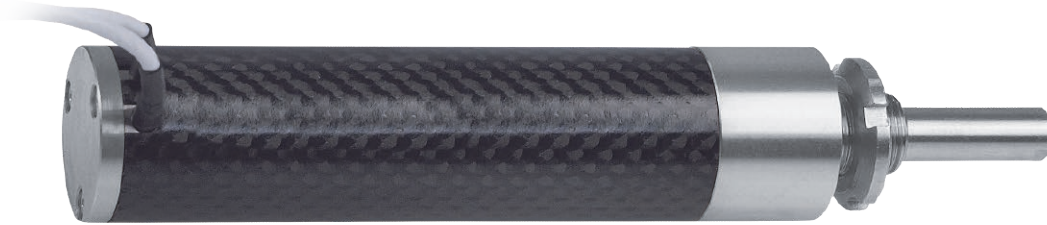

N-381, dimensions in mm.

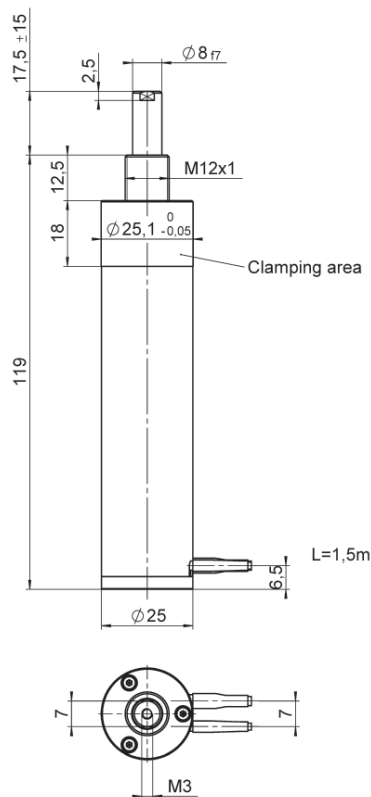

- Travel range 30 mm
- Force generation up to 10 N
- With NEXACT® piezo stepping drive
- Optional: Integrated linear encoder with 20 nm resolution

Applications

- Industrial precision motion
- Semiconductor technology
- Semiconductor testing
- Wafer inspection
- Lithography
- Nano imprint
- Nanometrology
- Motion in strong magnetic fields and vacuum

- >> Incremental Encoder
- >> PiezoWalk® Walking Drive

Technology Glossary page 240

	N-381.30	N-381.3A
Active axes	X	X
Motion and positioning		
Travel range	30 mm	30 mm
Integrated sensor	–	Incremental linear encoder
Sensor resolution	–	20 nm*
Travel range in analog mode, open-loop	±5 µm (max.)	±5 µm (max.)
Open-loop resolution	0.03 nm**	0.03 nm**
Closed-loop resolution	–	20 nm*
Max. velocity	10 mm/s*	10 mm/s*
Mechanical properties		
Stiffness in motion direction	2.4 N/µm	2.4 N/µm
Max. push / pull force (active)	10 N	10 N
Max. holding force (passive)	15 N	15 N
Drive properties		
Drive type	NEXACT® linear drive	NEXACT® linear drive
Operating voltage	–10 V to +45 V	–10 V to +45 V
Miscellaneous		
Operating temperature range	0 to 50 °C	0 to 50 °C
Material	Stainless steel / CFRP	Stainless steel / CFRP
Mass	250 g	255 g
Cable length	1.5 m	1.5 m
Connector	HD Sub-D 15 (m) (motor)	HD Sub-D 15 (m) (motor) HD Sub-D 15 (f) (sensor)
Recommended electronics	E-712.1AM, E-861	E-712.1AM, E-861

* With E-861. Depending on drive electronics.

** 1 nm with E-861. Depending on drive electronics.

All specifications based on room temperature (22 °C ±3 °C).

Ask about custom designs!

E-712.1AN / E-712.2AN / E-712.3AN PICMAWalk Digital Controller

1 to 3 Channels, for Drives with Incremental Sensors



- Customized control algorithms for PICMAWalk walking drives
- For one to three channels
- Plug-and-play, thanks to PI proprietary controller technology
- Flexible interfaces: TCP/IP, USB, RS-232, SPI
- Compatible with GCS (PI General Command Set)

Digital controller for PICMAWalk walking drives

1 to 3 channels with integrated power amplifiers and interpolator. All PiezoWalk® technology modes of motion supported. 20-bit digital-analog converter resolution. Linearization based on fourth-order polynomials.

Extensive functionality

Wave generator. Trigger inputs and outputs. Data recorder. Various control algorithms can be selected, including PID position control with secondary velocity control or PID velocity control. Parameter changing during operation. Extensive software support, e.g., for LabVIEW.

Interfaces

Ethernet, USB, RS-232, and SPI for commanding. Differential signal transmission for analog (sin/cos) encoder signals. TTL signal inputs for reference point switch.

>> Extensive Software Package

Technology Glossary page 240

E-712.1AN · E-712.2AN · E-712.3AN	
Housing with wide-range-input power supply	
Control input voltage	100 to 240 V AC
Input voltage frequency	50 to 60 Hz
Maximum power consumption	225 VA
Fuse	2 ATH
Digital processor and interface module	
Supported positioning systems	PICMAWalk
Interfaces for communication	TCP/IP, USB, RS-232, SPI
Supported axes	E-712.1AN: 1 axis E-712.2AN: 2 axes E-712.3AN: 3 axes
Processor	PC-based
Sampling rate, servo control	Max. 50 kHz
Sampling rate, sensor	Max. 50 kHz
External sensor synchronization	Yes
Digital inputs	8 × TTL to MDR connection, 20 pin
Digital outputs	8 × TTL to MDR connection, 20 pin
Command set	PI General Command Set (GCS) 2.0
Supported functions	Function generator, trigger inputs and outputs, data recorder; various control algorithms can be selected, e.g.: <ul style="list-style-type: none"> ■ P, I, two notch filters ■ Advanced Piezo Control, must be ordered separately (order number E-712.U1) ■ PID position control with secondary velocity control, two notch filters ■ PID velocity control, two notch filters
Display	LEDs for OnTarget, Err, Power
Linearization	Fourth-order polynomials DDL option (Dynamic Digital Linearization), must be ordered separately (order number E-710.SCN) Advanced Linearization option, must be ordered separately (order number E-712.U4)
Amplifier and control module	
Min. output voltage	-30 V
Max. output voltage	135 V
Amplifier channels per module	4
Peak output power per channel	25 W*
Average output power per channel	8 W
Peak output current per channel	250 mA
Average output current per channel	150 mA
Current limitation	Short-circuit proof
Digital-analog converter resolution	20 bit effective
Temperature sensor	Max. 75 °C, deactivation of the piezo output voltage
Connection	Sub-D 37 (f)
Dimensions	270 mm × 324 mm × 139 mm (L × W × H)
Mass	E-712.1AN: 4.1 kg E-712.2AN: 4.62 kg E-712.3AN: 5.13 kg

* The maximum output power is limited by the power supply of the housing and the number of available channels.

E-712.1AM Digital Motion Controller

For NEXLINE® Piezo Stepping Drives



- Special control algorithms for NEXLINE® nanopositioning linear-motor actuators
- Highly stable 20-bit D/A converter
- Servo frequency 50 kHz
- Flexible interfaces: Ethernet TCP/IP, RS-232, USB

Digital Motion Controller

The E-712.1AM is a high-performance single channel piezo controller for high-precision and powerful NEXLINE® drives with incremental encoders. It is equipped with high-performance, low-noise amplifiers and is capable of controlling NEXLINE® step algorithms. The P-I controller offers 2 configurable notch filters.

Comprehensive Functions

The controller is equipped with a data recorder and a wave generator. The comprehensive software package also contains LabVIEW drivers and shared libraries for Windows and Linux.

Interfaces

Ethernet, USB, RS-232 as well as 8 digital inputs and outputs each for triggers. The LEMO interface enables external synchronization.

>> Extensive Software Package

Technology Glossary page 240

	E 712.1AM	Unit
Function	Modular digital controller for NEXLINE® piezo stepping drives	
Axes	1	
Processor	PC-based, real-time operating system	
Servo frequency	50	kHz
Sensor		
Servo characteristics	P-I, two notch filters	
Sensor type	Incremental, analog signals (sin/cos)	
Sensor resolution	16-bit, quantized	bit
External synchronization	Yes	
Amplifier		
Amplifier channels	4	
Output voltage	-250 to 250	V
Peak output power per channel	45	W
Average output power per channel	15	W
Peak output current per channel	180	mA
Average output current per channel	60	mA
Current limitation	Short-circuit-proof	
Resolution DAC	20-bit, interpolated	bit
Overheat protection	Output voltage switch-off at 75 °C	
Interfaces and operation		
Interface / communication	Ethernet, USB, RS-232	
Piezo / sensor connection	Sub-D 25-pin (f)	
Digital input/output	MDR20; 8 × IN, 8 × OUT; TTL	
Command set	PI General Command Set (GCS)	
User software	NanoCapture, PIMikroMove	
Software drivers	LabVIEW driver, shared libraries for Windows and Linux	
Supported functions	NEXLINE® servo algorithms, data recorder, wave generator, trigger I/O	
Display and indicators	LEDs for OnTarget, Error, Power	
Linearization	4 th order polynomials, DDL option (Dynamic Digital Linearization)	
Miscellaneous		
Operating temperature range	5 to 50	°C
Mass	5.35	kg
Dimensions	9.5" chassis, 236 mm × 132 mm × 296 mm + handles (47 mm length)	
Max. power consumption	100	W
Operating voltage	90 to 240 VAC, 50 to 60 Hz	

Ask about custom designs!

E-861 PiezoWalk® NEXACT® Controller / Driver

Networkable Controller for NEXACT® Linear Drives and Positioners



- High-speed encoder input
- Macro programmable for stand-alone functionality
- Data recorder
- Nonvolatile EEPROM for macros and parameters
- USB, RS-232
- Controller module for C-885 PIMotionMaster available



>> Extensive Software Package

Technology Glossary page 240

E-861.1A1	
Function	Controller for NEXACT® drives / systems
Drive type	NEXACT® linear drive
Channels	1
Motion and control	
Servo characteristics	P-I-D servo control, parameter change on-the-fly
Trajectory profile modes	Trapezoidal
Encoder input	Analog encoder input sine-cosine, interpolation selectable up to 1000; Interpolation circuit for differential transmission, 1 V _{pp} amplitude and 2.5 V offset of the encoder signal
Stall detection	Servo off, triggered by programmable position error
Input limit switch	2 × TTL (pull-up/pull-down, programmable)
Input reference switch	1 × TTL
Electrical properties	
Max. output power	40 W
Output voltage	-10 to +45 V
Max. operating current	2 A
Interfaces and operation	
Communication interfaces	USB 1.0, RS-232 (9-pin (m) sub-D)
Motor connector	HD Sub-D 15-pin (f)
Sensor connection	HD Sub-D 15-pin (m)
Controller network	Up to 16 units on single interface*
I/O ports	4 analog/digital in, 4 digital out (TTL)
Command set	PI General Command Set (GCS)
User software	PIMikroMove, PITerminal
Software drivers	GCS DLL, LabVIEW driver
Supported functionality	Start-up macro; Data recorder for recording operating data such as motor voltage, velocity, position or position error; internal safety circuitry: watchdog timer
Manual control (optional)	Pushbutton box, joystick (for 2 axes), Y-cable for 2-D motion
Miscellaneous	
Operating voltage	24 V; included: external power supply, 24 V; 2.0 A
Operating temperature range	0 to 50 °C
Mass	1.1 kg
Dimensions	206 mm × 130 mm × 66 mm (incl. mounting rails)

* 16 units with USB; 6 units with RS-232.

E-862 NEXACT® Drive Electronics

Low-Cost Drive Electronics for NEXACT® Piezo Stepping Drives



- Step generator for NEXACT® piezomotors
- Integrated power amplifier
- Versatile and inexpensive
- Interface for automation, joystick for manual operation
- OEM version

>> Extensive Software Package

Technology Glossary page 240

E-862.100	
Function	Drive electronics for NEXACT® drives / stages
Drive type	NEXACT® Drive
Channels	1
Motion resolution	12 bit
Input limit switch	2 x TTL (active high, to be activated)
Electrical properties	
Output power	max. 40 W
Output voltage	0 to +45 V
Current consumption	max. 1.6 A
Interface and operation	
Control Mode	±10 V analog velocity control
Motor connector	HD Sub-D 15-pin (f)
Manual control (optional)	Joystick, Y-cable for control of 2 axes with joystick
Miscellaneous	
Operating voltage	24 V External power supply (24 V, 2 A), not included
Operating temperature range	0 to 50 °C
Mass	0.64 kg
Dimensions	166 mm x 100 mm x 46 mm (incl. mounting rails)

All specifications for NEXACT® drives refer to use with E-861 controller.
 Compared to the E-861 controller for NEXACT® drives/stages, the E-862 drive electronics provides only a unipolar output voltage.
 Therefore, push force and velocity achievable with E-862 are derated by approx. 20 %.

Capacitive Feedback Sensors



Sensor Heads	178
D-015 / D-050 / D-100 Capacitive Sensors	180
D-510 PISeca Capacitive Sensors	182

Signal Conditioner	184
E-852 PISeca Signal Conditioner	184

D-015 / D-050 / D-100 Capacitive Sensors

Sub-Nanometer-Resolution Position Sensors

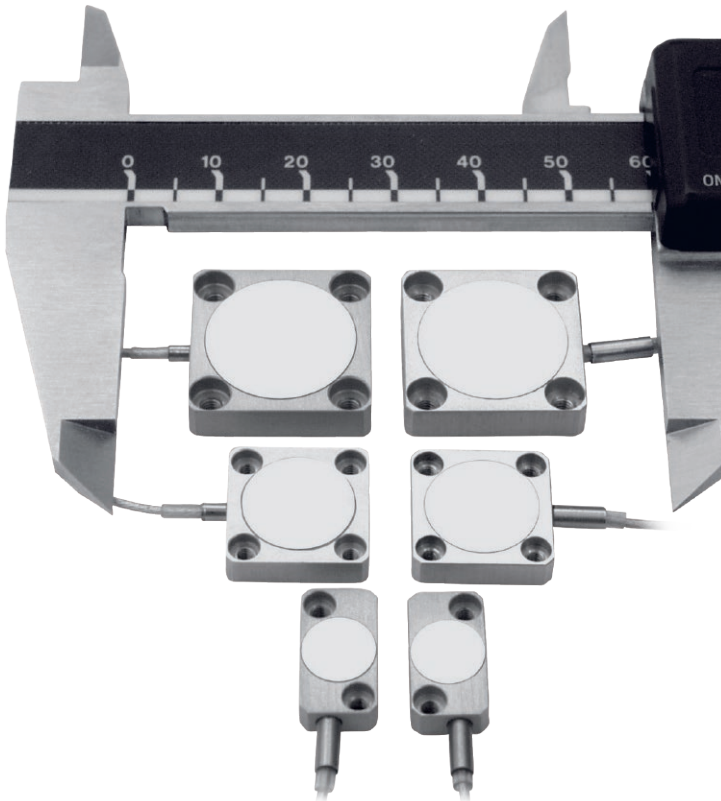

- For applications requiring highest precision
- Measurement range to 1000 μm
- Resolution to 0.01 nm
- Linearity error to 0.01 % with digital controller
- Bandwidth to 10 kHz
- Custom designs on request
- Signal conditioner / servo module available

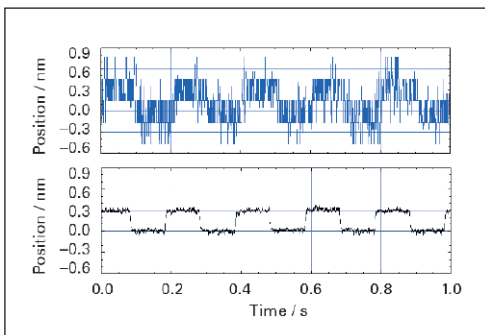

Piezo nanopositioning system making 0.3 nm steps, measured with PI capacitive sensor (lower curve) and with a highly precise laser interferometer. The capacitive sensor provides significantly higher resolution than the interferometer.

D-015.00, dimensions in mm

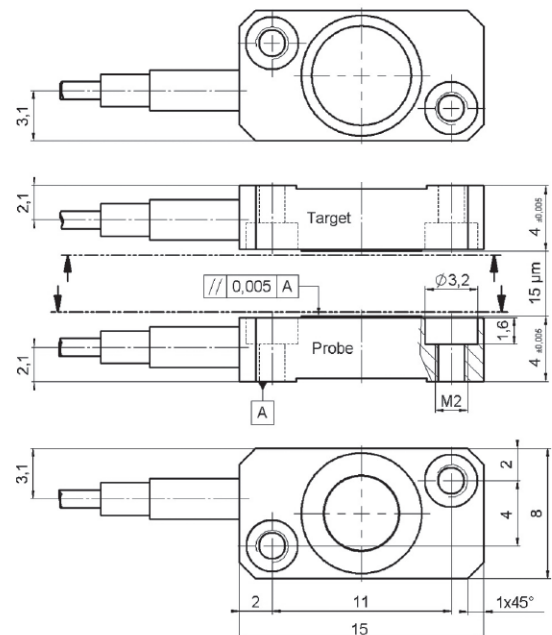

Applications

- High precision positioning

- >> Capacitive Feedback Sensors
- >> Direct Metrology

Technology Glossary page 240

	D-015.00	D-050.00	D-100.00	Unit
Sensor				
Sensor type	Capacitive	Capacitive	Capacitive	
Nominal measurement range	15	50	100	μm
Extended measurement range	45	150	300	μm
Resolution*	0.0005	0.0005	0.0005	% of measurement range
Linearity error**	0.01	0.01	0.01	%
Sensor active area	16.6	56.5	113.1	mm ²
Thermal drift***	50	50	50	ppm/K
Miscellaneous				
Operating temperature range	-20 to 80	-20 to 80	-20 to 80	°C
Material	Aluminum	Aluminum	Aluminum	
Recommended sensor electronics	E-509.CxA	E-509.CxA	E-509.CxA	

* 3 kHz, with E-509.C3A servo controller.

** With digital controller. Up to 0.05 % with E-509 analog controller.

*** Change of active surface size in ppm (parts per million), refers to measurement range.

Ask for custom materials.

D-050.00, dimensions in mm

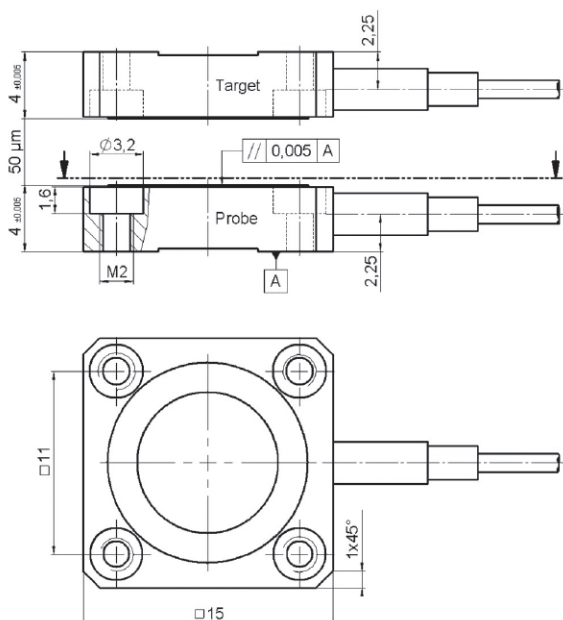

D-100.00, dimensions in mm

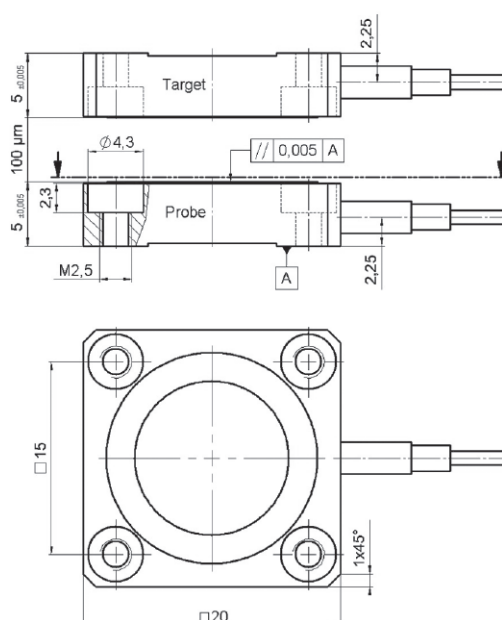

D-510 PISeCa Capacitive Sensors

Single-Plate Sensors with Excellent Position Resolution



- Non-contact measurement for distance / motion / vibration
- Absolute position sensing
- Sub-nanometer resolution
- Selectable measurement ranges
- Easy integration
- Bench-top or rackmount signal conditioners available

D-510.021, D-510.051 and D-510.101 capacitive sensor probes, dimensions in mm. Sensor connection LEMO FFC00.650.CLA.543, triaxial

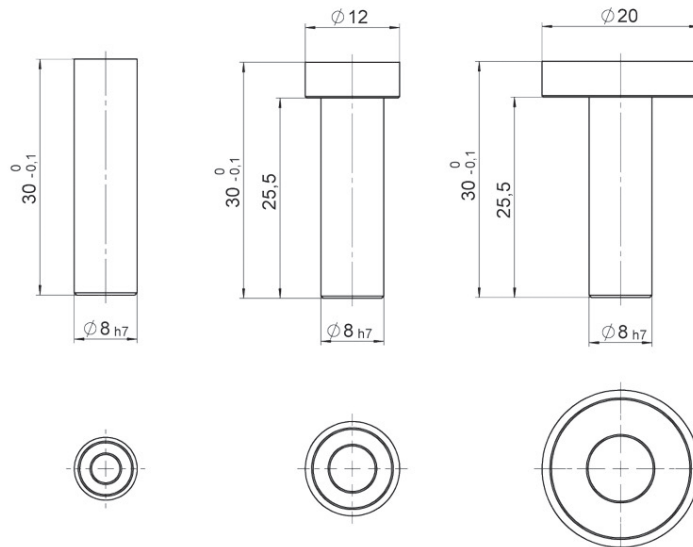

Applications

- Semiconductor technology
- Semiconductor testing
- Nanometrology
- Active vibration damping
- High precision machining

- >> Capacitive Feedback Sensors
- >> Direct Metrology

Technology Glossary page 240

	D-510.021	D-510.051	D-510.101	Unit	Tolerance
Sensor type	Single-electrode, capacitive	Single-electrode, capacitive	Single-electrode, capacitive		
Measurement accuracy					
Nominal measurement range*	20	50	100	µm	
gap	10	25	50	µm	min.
gap	150	375	750	µm	max.
Static resolution**	<0.001	<0.001	<0.001	% of measurement range	typ.
Dynamic resolution**	<0.002	<0.002	<0.002	% of measurement range	
Linearity error***	<0.2	<0.1	<0.1	%	
Mechanical properties					
Sensor active diameter	3.8	6	8.4	mm	
Sensor active area	11.2	27.9	56.1	mm ²	
Sensor diameter	8	12	20	mm	
Sensor area	50.3	113.1	314.0	mm ²	
Mounting shaft diameter	8	8	8	mm	
Miscellaneous					
Operating temperature range	-20 to 100	-20 to 100	-20 to 100	°C	
Material	stainless steel	stainless steel	stainless steel		
Mass	8	10	16	g	±5 %
Recommended signal conditioner electronics	E-852.10	E-852.10	E-852.10		

* Extended measurement ranges available for calibration with E-852.10 signal conditioner electronics

** Static: bandwidth 10 Hz, dynamic: bandwidth 10 kHz, with E-852.10 signal conditioner electronics

*** Linearity error over nominal measurement range

D-510.021 with LEMO connector for easy handling



E-852 PISeCa Signal Conditioner

For Capacitive Single-Plate Sensors



- Cost-effective system solution for PISeCa capacitive position sensors
- ILS circuitry optimizes capacitive sensor linearity
- Selectable bandwidth from 10 Hz up to 10 kHz
- Selectable measurement range
- LED-bar measuring-range display for easy integration
- External synchronization for multi-channel applications
- Low-noise power supply included

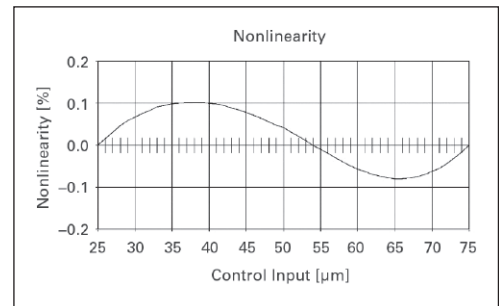

E-852 signal conditioner, dimensions in mm

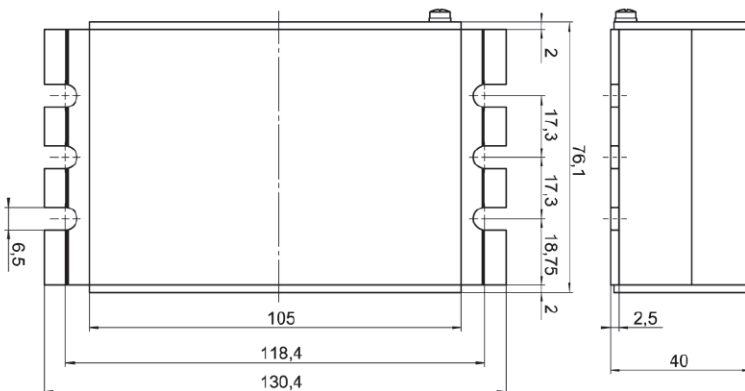

Excellent output linearity of the E-852 signal conditioner / D-510.050 sensor combination (nominal measurement range)

- >> Capacitive Feedback Sensors
- >> Direct Metrology

Technology Glossary page 240

	E-852	E-852.10A1	Unit
Function	Signal conditioner for PISeca	Signal conditioner for single-electrode capacitive sensors, remote operation	
Channels	1	1	
Sensor			
Sensor type	Single-electrode, capacitive	Single-electrode, capacitive	
Sensor bandwidth	10 / 3 / 0.3 1.1 / 0.1 / 0.01 (optional)	10 / 3 / 1 / 0.3 / 0.01	kHz
Measurement range extension factors*	1 & 2.5 (calibrated); 2 & 5 (optional)	1 (calibrated) / 2 / 2.5 / 5 (on request)	
Ext. synchronization	Auto master-slave	Auto master-slave	
Temperature stability	0.71 ±0.25	0.2	mV/K
Electrical properties			
Output voltage	-10 to 10 / -5 to 5 / 0 to 10 (selectable)	-10 to 10 / -5 to 5 / 0 to 10 (selectable)	V
Output signal	1 kΩ / 1 nF	1 kΩ / 1 nF	
Supply voltage	±15 V (125 mA), 5 V (20 mA)	±15 V (220 mA), 5 V (20 mA)	
Static resolution**	<0.001 of measurement range (RMS)	<0.001 of measurement range (RMS)	%
Dynamic resolution**	<0.002 of measurement range (RMS)	<0.002 of measurement range (RMS)	%
Noise factor***	0.14	0.14	pp/m √Hz
Linearity @ nominal range	<0.1 (<0.2 for D-510.020)	<0.1 (<0.2 for D-510.020)	%
Interfaces and operation			
Sensor connection	LEMO ECP00.650.NLL.543 socket, triaxial	LEMO ECP00.650.NLL.543 socket, triaxial (on signal amplifier); Sub-D 9-pin, 10 m cable from preamp to signal conditioner, differential signals	
Signal output	BNC	BNC	
Signal monitor	-	Test point on signal amplifier	
Display	LED bar	Power On	
Linearization	ILS	ILS	
Miscellaneous			
Operating temperature range	5 to 40	5 to 40	°C
Mass	Signal conditioner: 0.355 Power supply E-852.PS2: 0.55	Signal conditioner: 0.355 Power supply E-852.PS2: 0.55 Signal amplifier: 0.076	
Dimensions	Signal conditioner: 80 mm × 130 mm × 40 mm Power supply E-852.PS2: 146 mm × 76 mm × 43 mm (incl. mounting flanges)	Signal conditioner: 80 mm × 130 mm × 40 mm Power supply E-852.PS2: 146 mm × 76 mm × 43 mm Preamp: 55 mm × 70 mm × 20 mm (incl. mounting flanges)	
Target ground connector	Banana jack, 4 mm	Banana jack, 4 mm, on signal amplifier	

* Extension factors to multiply by the nominal measurement range of D-510 sensor probes

** Static: bandwidth 10 Hz, dynamic: bandwidth 10 kHz, cable length 1 m

*** Specifications in ppm (parts per million), refer to nominal measurement range

Piezo Controllers and Drivers

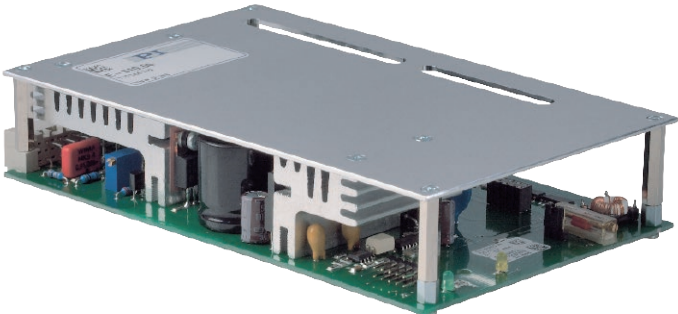

Single-Channel Piezo Controllers	186
E-754 Digital Piezo Controller	188
E-709 Compact and Cost-Optimized Digital Piezo Controller	190
E-709.CHG Digital Single Channel Piezo Controller	192
E-610 Piezo Amplifier / Servo Controller	194
E-625 Piezo Servo-Controller & Driver	196
E-665 Piezo Amplifier / Servo Controller	198
E-621 Piezo Servo-Controller & Driver	200

Multi-Channel Piezo Controllers	202
E-727 Digital Multi-Channel Piezo Controller.....	202
E-616 Controller for Multi-Axis Piezo Tip / Tilt Mirrors and Platforms	206
E-536 PicoCube Piezo Controller	208

Modular Multi-Channel Piezo Controllers	210
E-712 Digital Piezo Controller	210
E-500 Modular Piezo Controller	216

Controller for Piezo Benders	222
E-651 / E-614 Piezo Amplifier / Servo Controller.....	222

High Dynamics Piezo Drivers	224
E-617 High-Power Piezo Amplifier	224
E-618 High-Power Piezo Amplifier / Servo Controller	226
E-470 / E-472 / E-421 PICA Piezo Controller	228
E-481 PICA Piezo High-Power Amplifier/ Controller	230
E-482 PICA High-Power Piezo Driver / Servo Controller	232

Piezo Drivers	234
E-663 Three-Channel Piezo Driver.....	234
E-464 PICA Piezo Driver / Amplifier	236
E-462 PICA Piezo Driver.....	238

E-754 Digital Piezo Controller

High-Speed, Single-Axis Controller

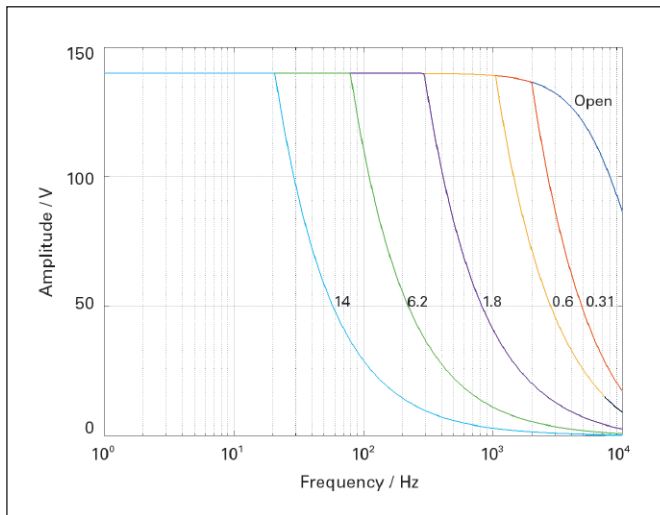

E-754: Operating limits (open-loop) with various capacitive loads, capacitance values in μF

- Next generation digital controller provides higher flexibility, accuracy and speed
- Autoloading of calibration data from stage ID chip for interchangeability of controller and mechanics
- Ethernet (TCP/IP), SPI, USB, RS-232
- Analog inputs and outputs
- Digital I/O lines for task triggering
- High dynamic bandwidth
- Integrated motion profile generator

>> Extensive Software Package
>> Linearization

Technology Glossary page 240

E-754.1CD	
Function	Digital controller for single-axis piezo nanopositioning systems with capacitive sensors
Axes	1
Processor	375 MHz, 64-bit floating point, DSP/ARM
Supported functions	Wave generator, trigger I/O, AutoZero, data recorder, macros
Sampling rate, servo control	50 kHz
Sampling rate, sensor	50 kHz
Sensor	
Controller type	P-I, two notch filters, optional APC
Sensor type	Capacitive
Sensor channels	1
Sensor bandwidth	8 kHz
Sensor resolution	19 bit
External synchronization	100 kHz and 4.8 MHz (LVDS)
Amplifier	
Output voltage	-30 to 135 V
Amplifier channels	1
Peak output power, <2 ms	45 W
Average output power	15 W
Peak output current, <2 ms	500 mA
Average output current	120 mA at 20 °C
Current limitation	Short-circuit proof
Resolution DAC	22 bit effective
Interfaces and operation	
Communication interfaces	Ethernet (TCP/IP), SPI, USB, RS-232
Piezo / sensor connection	Sub-D 7W2 (f)
Analog input	LEMO, 1 channel, ±10 V, 20-bit ADC
Analog output	LEMO, 1 channel, ±10 V, 20-bit DAC
Digital input	LEMO, 2 lines, TTL
Digital output	LEMO, 2 lines, TTL
Command set	PI General Command Set (GCS)
User software	PIMikroMove
Software drivers	LabVIEW driver, dynamic libraries for Windows and Linux
Display and indicators	Status LEDs
Linearization	4th order polynomials; optional DDL
Separate protective earth connection	Yes
Miscellaneous	
Operating temperature range	5 to 40 °C
Overheat protection	Automatic deactivation of the piezo output at temperatures higher than 70 °C
Mass	1.6 kg
Power consumption, full load	35 W (max.)
Power consumption, no load	13 W
Operating voltage	24 V DC from external power supply (included in the scope of delivery)
Dimensions	312 mm × 153 mm × 59 mm (incl. mounting rails)

Ask about custom designs!

E-709 Compact and Cost-Optimized Digital Piezo Controller

For SGS, Piezoresistive and Capacitive Sensors

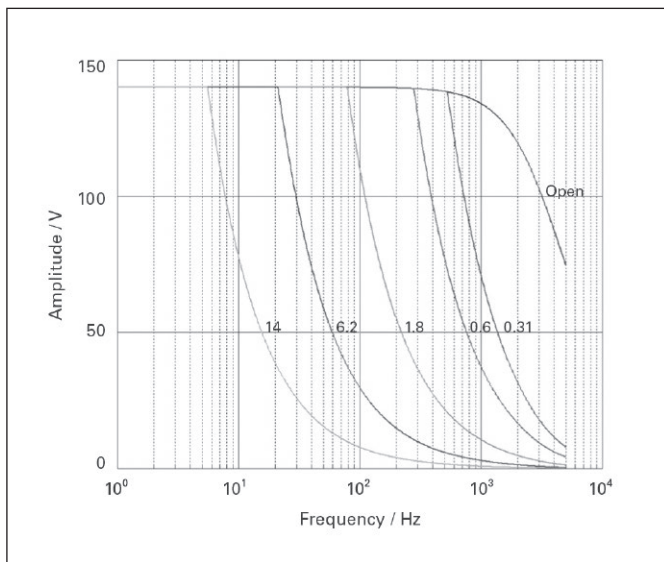

E-709: Operating limits with various PZT loads (open-loop), capacitance is measured in μF

- Linearity error to 0.02 %
- Fast 25 Mbit/s serial interface
- Comprehensive I/O functions
- Low-cost OEM versions available
- USB, digital RS-232
- High-power version E-709.CHG

E-709 OEM version board

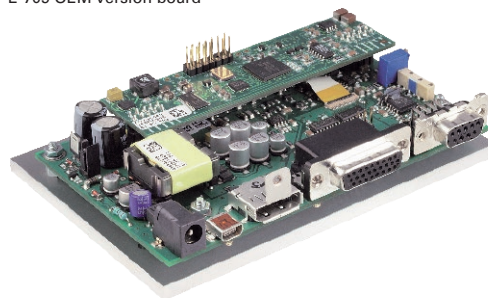

>> Extensive software package

Technology Glossary page 240

	E-709.SR / E-709.SRG	E-709.PR / E-709.PRG	E-709.CR / E-709.CRG
Sensor type	Strain Gauge Sensors	Piezoresistive sensors	Capacitive sensors
Function	Digital controller for single-axis piezo nanopositioning systems (.SR: OEM board)	Digital controller for single-axis piezo nanopositioning systems (.PR: OEM board)	Digital controller for single-axis piezo nanopositioning systems (.CR: OEM board)
Channels	1	1	1
Processor	DSP 32-bit floating point, 150 MHz	DSP 32-bit floating point, 150 MHz	DSP 32-bit floating point, 150 MHz
Servo characteristics	P-I, two notch filters, sensor linearization	P-I, two notch filters, sensor linearization	P-I, two notch filters, sensor linearization
Sampling rate, servo-control	10 kHz	10 kHz	10 kHz
Sampling rate, sensor	10 kHz	10 kHz	10 kHz
Sensor			
Linearization	5 th order polynomials	5 th order polynomials	5 th order polynomials
Sensor bandwidth	5 kHz	5 kHz	5 kHz
Sensor resolution	16 bit	16 bit	16 bit
Ext. synchronization	No	No	No
Amplifier			
Output voltage	-30 V to 130 V	-30 V to 130 V	-30 V to 130 V
Peak output power (<5 ms)	10 W	10 W	10 W
Average output power (>5 ms)	5 W	5 W	5 W
Peak current (<5 ms)	100 mA	100 mA	100 mA
Average output current (>5 ms)	50 mA	50 mA	50 mA
Current limitation	Short-circuit-proof	Short-circuit-proof	Short-circuit-proof
Resolution DAC	17 bit	17 bit	17 bit
Interfaces and operation			
Communication interfaces	USB, RS-232, SPI	USB, RS-232, SPI	USB, RS-232, SPI
Piezo / sensor connection	Sub-D, 9-pin	Sub-D, 9-pin	Sub-D special connector
I/O connector	HD Sub-D 26-pin 1 analog input 0 to 10 V 1 sensor monitor 0 to 10 V 1 digital input (LVTTTL, programmable) 1 analog output 5 digital outputs (LVTTTL, 3 x predefined, 2 x programmable)	HD Sub-D 26-pin 1 analog input 0 to 10 V 1 sensor monitor 0 to 10 V 1 digital input (LVTTTL, programmable) 1 analog output 5 digital outputs (LVTTTL, 3 x predefined, 2 x programmable)	HD Sub-D 26-pin 1 analog input 0 to 10 V 1 sensor monitor 0 to 10 V 1 digital input (LVTTTL, programmable) 1 analog output 5 digital outputs (LVTTTL, 3 x predefined, 2 x programmable)
Command set	PI General Command Set (GCS)	PI General Command Set (GCS)	PI General Command Set (GCS)
User software	PIMikroMove	PIMikroMove	PIMikroMove
Software drivers	LabVIEW driver, dynamic libraries for Windows and Linux, MATLAB, MetaMorph, µManager, Andor iQ	LabVIEW driver, dynamic libraries for Windows and Linux, MATLAB, MetaMorph, µManager, Andor iQ	LabVIEW driver, dynamic libraries for Windows and Linux, MATLAB, MetaMorph, µManager, Andor iQ
Supported functions	Wave generator, data recorder, auto zero, trigger I/O	Wave generator, data recorder, auto zero, trigger I/O	Wave generator, data recorder, auto zero, trigger I/O
Display	Status LED, overflow LED	Status LED, overflow LED	Status LED, overflow LED
Miscellaneous			
Operating temperature range	8 to 50°C (above 40°C, power derated)	8 to 50°C (above 40°C, power derated)	12 to 50°C (above 40°C, power derated)
Dimensions	160 mm x 96 mm x 33 mm	160 mm x 96 mm x 33 mm	160 mm x 96 mm x 33 mm
Mass	260 g / 470 g	260 g / 470 g	260 g / 470 g
Operating voltage	24 VDC	24 VDC	24 VDC
Max. power consumption	24 W	24 W	24 W

E-709.CHG Digital Single Channel Piezo Controller

High Output Power for Dynamic Operation, Capacitive Sensors

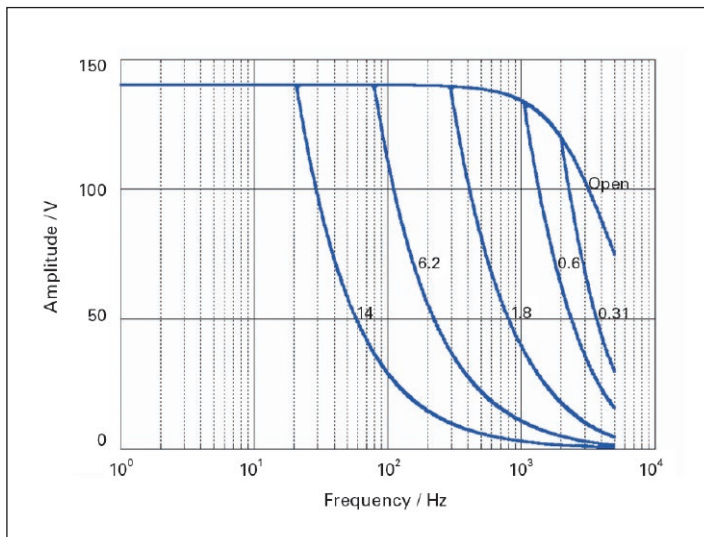

E-709.CHG: Operating limits (open-loop) with different PZT loads, capacity is measured in μF

- Output power up to 50 W
- Linearity error up to 0.02 %
- USB, RS-232
- SPI: Fast 25 Mbit/s serial interface
- Comprehensive I/O functions

>> Extensive software package

Technology Glossary page 240

E-709.CHG	
Function	Digital, highly dynamic controller for single-axis piezo nanopositioning systems
Channels	1
Processor	DSP 32-bit floating point, 150 MHz
Servo characteristics	P-I, 2 notch filter, sensor linearization
Sampling rate, servo-control	10 kHz
Sampling rate, sensor	10 kHz
Sensor	
Sensor type	Capacitive
Linearization	5 th order polynomials
Sensor bandwidth	5 kHz
Sensor resolution	16 bit
Ext. synchronization	Yes
Amplifier	
Output voltage	-30 to 130 V
Peak output power, <2 ms	50 W
Average output power (>5 ms)	15 W
Peak current, <2 ms	500 mA
Average output current (>5 ms)	160 mA
Current limitation	Short-circuit-proof
Resolution DAC	17 bit
Interface and operation	
Communication interfaces	USB, RS-232, SPI
Piezo / sensor connection	Sub-D special connector
I/O connector	HD Sub-D 26-pin 1 analog input 0 to 10 V 1 sensor monitor 0 to 10 V 1 digital input (LVTTTL, programmable) 1 analog output 5 digital outputs (LVTTTL, 3 x predefined, 2 x programmable)
Command set	PI General Command Set (GCS)
User software	PIMikroMove, NanoCapture
Software drivers	LabVIEW driver, shared libraries for Windows and Linux. Supported by MATLAB, MetaMorph, µManager, Andor iQ
Supported functionality	Wave generator, Datenrecorder, auto zero, trigger I/O
Display	Status LED, overflow LED
Miscellaneous	
Operating temperature range	5 to 50 °C
Dimensions	320 mm x 150 mm x 80 mm
Mass	2.5 kg
Operating voltage	24 VDC, in the scope of delivery: external power supply
Max. power consumption	45 W

E-610 Piezo Amplifier / Servo Controller

1-Channel OEM Piezo Driver Module with Optional Position Servo-Control

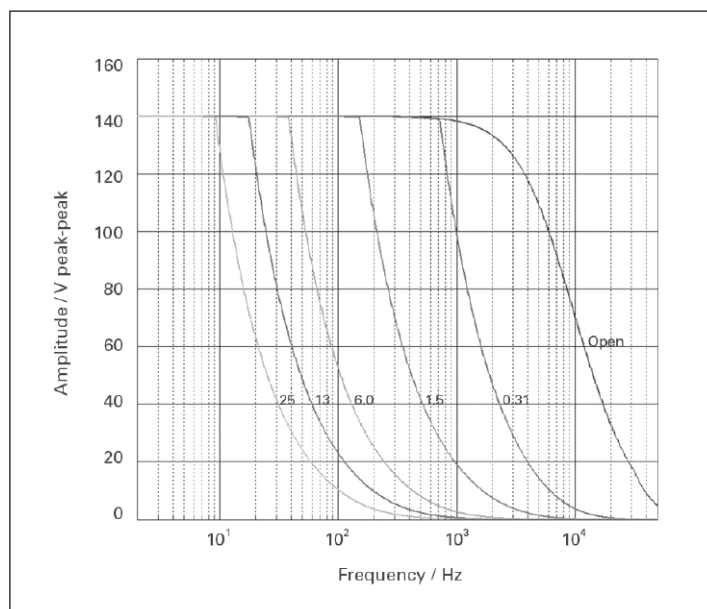
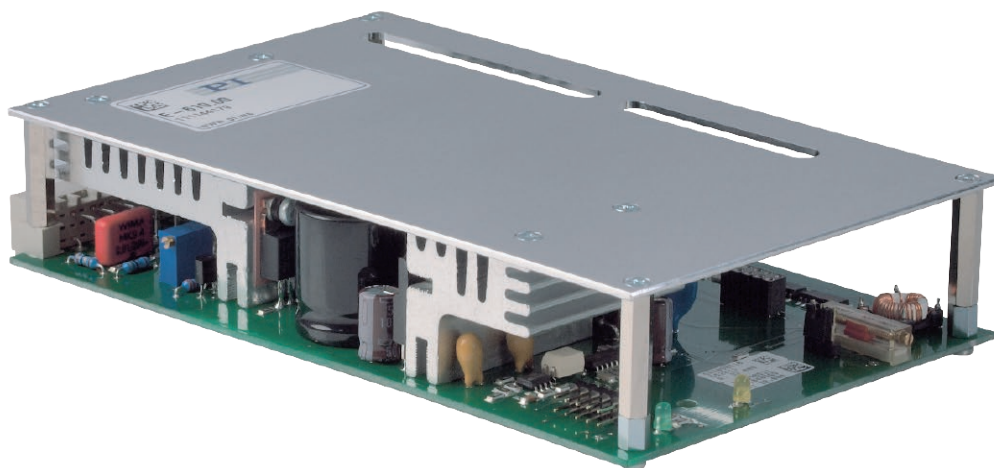

E-610: Operating limits with various PZT loads (open-loop), capacitance is measured in μF

- Inexpensive 1-channel OEM solution
- Closed-loop and open-loop versions
- Notch filter for higher bandwidth
- Position control for SGS and capacitive sensors
- Peak current 180 mA
- Capacitive and SGS feedback sensors

	E-610.00	E-610.C0	E-610.S0	Unit
Function	Piezo Amplifier, 1 Channel, OEM Module	Piezo Amplifier / Servo-Controller, OEM Module	Piezo Amplifier / Servo-Controller, OEM Module	
Sensor				
Servo characteristics	–	P-I (analog), notch filter	P-I (analog), notch filter	
Sensor type	–	Capacitive	SGS	
Amplifier				
Control input voltage	–2 to 12	–2 to 12	–2 to 12	V
Output voltage	–30 to 130	–30 to 130	–30 to 130	V
Peak current	180 (<15 ms)	180 (<50 ms)	180 (<15 ms)	mA
Average current	100	100	100	mA
Current limitation	Short-circuit-proof	Short-circuit-proof	Short-circuit-proof	
Noise, 0 to 100 kHz	1.6	0.5	1.6	mV _{rms}
Voltage gain	10 ±0.1	10 ±0.1	10 ±0.1	
Input impedance	100	100	100	kΩ
Interface and operation				
Input / Output	32-pin (m) on rear panel (DIN 41612 / D)	32-pin (m) on rear panel (DIN 41612 / D)	32-pin (m) on rear panel (DIN 41612 / D)	
Piezo connector	LEMO	LEMO	LEMO	
Sensor connection	–	LEMO	LEMO	
DC offset	External potentiometer (not included), adds 0 to 10 V to Control In	External potentiometer (not included), adds 0 to 10 V to Control In	External potentiometer (not included), adds 0 to 10 V to Control In	
Miscellaneous				
Operating temperature range	5 to 50	5 to 50	5 to 50	°C
Dimensions	7 HP / 3 RU	7 HP / 3 RU	7 HP / 3 RU	
Mass	0.3	0.35	0.35	kg
Operating voltage	12 to 30	12 to 30	12 to 30	VDC, stabilized
Current consumption, max.	2	2	2	A

E-625 Piezo Servo-Controller & Driver

Compact Bench-Top Device with High-Speed Interface

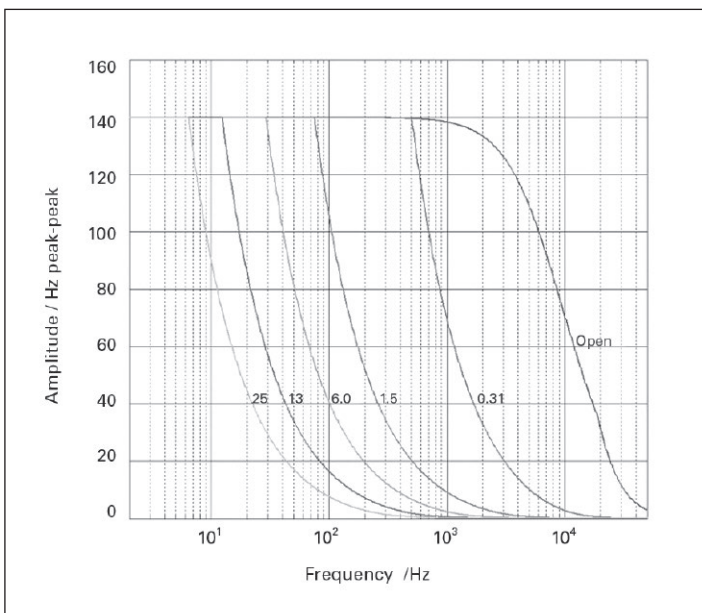

E-625: Operating limits with various PZT loads (open-loop), capacitance is measured in μF

- Integrated 24-Bit USB Interface
- Network capability with up to 12 channels
- Peak current 120 mA
- Position control for SGS and capacitive sensors
- Notch filter for higher bandwidth
- Table for User-Defined Curves
- Additional Analog Interface

>> Extensive software package

Technology Glossary page 240

E-625.SR / E-625.CR	
Function	Piezo amplifier / servo controller
Axes	1
Sensor	
Servo characteristics	P-I (analog), notch filter
Sensor type	SGS (.S) / capacitive (.C)
Amplifier	
Control input voltage range	-2 to +12 V
Min. output voltage	-30 to +130 V
Peak current, <50 ms	120 mA
Average current	60 mA
Current limitation	Short-circuit-proof
Noise, 0 to 100 kHz	0.8 mV _{rms}
Voltage gain	10 ±0.1
Input impedance	100 kΩ
Interfaces and operation	
Interface / communication*	USB, RS-232 (9-pin Sub-D connector, 9.6 – 115.2 kBaud), 24-bit A/D and 20-bit D/A
Piezo connector	LEMO ERA.00.250.CTL (.SR) / Sub-D special (.CR)
Sensor connection	LEMO EPL.0S.304.HLN (.SR) / Sub-D special (.CR)
Control input sockets	SMB
Sensor monitor socket	SMB
Controller network	up to 12 channels
Command set*	PI General Command Set (GCS)
User software*	PIMikroMove
Software drivers*	LabVIEW driver, dynamic libraries for Windows (DLL) and Linux
Supported functionality*	Wave table, 256 data points, external trigger, up to 16 macros
Miscellaneous	
Operating temperature range	5 to 50 °C
Overtemp protection	Deactivation at 75 °C
Dimensions	205 mm × 105 mm × 60 mm
Mass	1.05 kg
Operating voltage	12 to 30 V DC, stabilized
Current consumption	2 A

* E-625.S0 and E-625.C0 without digital interface.

E-665 Piezo Amplifier / Servo Controller

Display, Analog & Digital Interface

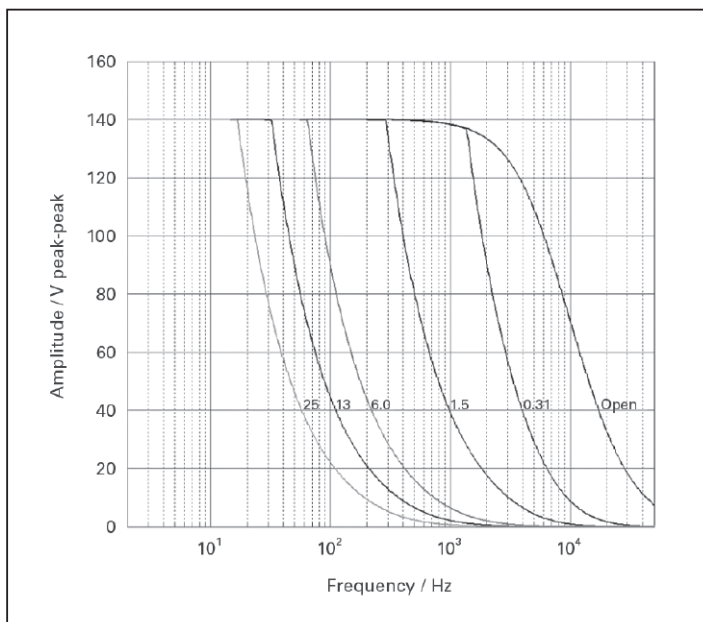

E-665: Operating limits with various PZT loads (open-loop), capacitance is measured in μF

- Integrated 24-Bit USB Interface
- Network capability with up to 12 channels
- Peak current 360 mA
- Notch filter for higher bandwidth
- Position control for SGS and capacitive sensors
- Table for User-Defined Curves
- RS-232 Analog Interface

>> Extensive software package

Technology Glossary page 240

E-665.SR / E-665.CR	
Function	Piezo amplifier & position servo-controller with digital interface
Axes	1
Sensor	
Servo characteristics	P-I (analog), notch filter
Sensor type	SGS (.SR) / capacitive (CR)
Amplifier	
Control input voltage range	-2 to +12 V
Output voltage	-30 to +130 V
Peak current, <20 ms	360 mA
Average current	150 mA
Current limitation	Short-circuit-proof
Noise, 0 to 100 kHz	0.5 (.SR) / 4.0 (.CR) mV _{rms}
Voltage gain	10 ±0.1
Input impedance	100 kΩ
Interface and operation	
Communication interfaces	USB, RS-232 (9-pin Sub-D connector, 9.6 – 115.2 kBaud), 24-bit A/D and 20-bit D/A
Piezo connector	LEMO ERA.00.250.CTL (.SR) / Sub-D special (.CR)
Sensor connection	LEMO EPL.0S.304.HLN (.SR) / Sub-D special (.CR)
Analog input	BNC
Sensor monitor socket	BNC
Controller network	up to 12 channels, parallel
Supported functionality	Wave table; 256 data points, external trigger, up to 16 macros
Display	2 × 4½ digit, LED
DC Offset	10-turn pot., adds 0 to 10 V to Control In
Miscellaneous	
Operating temperature range	5 to 40 °C
Overtemp protection	Deactivation at 85 °C
Dimensions	236 mm × 88 mm × 273 mm + handles
Mass	2.5 kg
Operating voltage	115 VAC / 230 VAC, 50-60 Hz (linear power supply)
Max. power consumption	60 W

Ask about custom designs!

E-621 Piezo Servo-Controller & Driver

Modules with Fast 24-Bit Interface



- Integrated 24-Bit USB Interface, RS-232
- Network capability with up to 12 channels
- Peak current up to 120mA
- Position control for SGS and capacitive sensors
- Notch filter for higher bandwidth
- Additional Analog Interface
- Table for User-Defined Curves

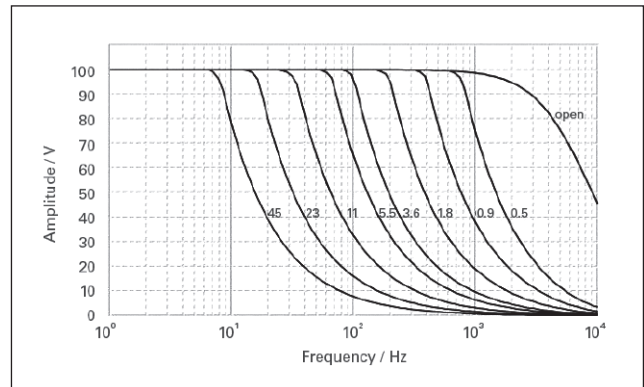

E-621.SR: operating limits with various PZT loads (open-loop), capacitance is measured in μF

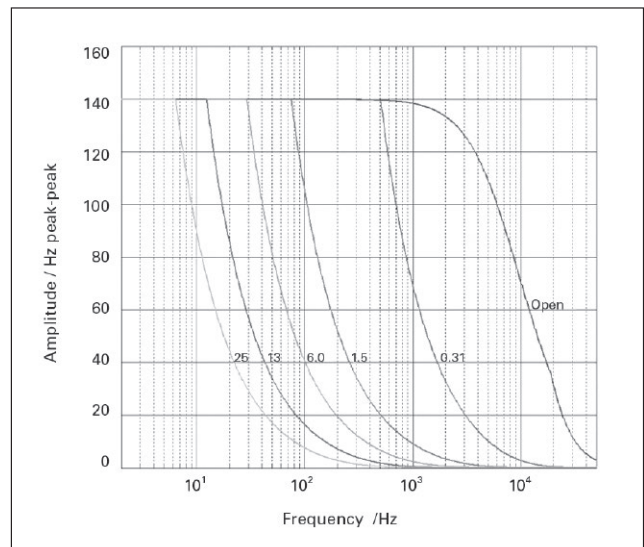

E-621: Operating limits with various PZT loads (open-loop), capacitance is measured in μF

E-621.SR / E-621.CR	
Function	Power amplifier & piezo controller
Sensor	
Servo characteristics	PI (analog), notch filter
Sensor type	SGS (.S) / capacitive (.C)
Amplifier	
Input voltage	-2 to +12 V
Output voltage	-30 to +130 V
Peak current, <50 ms	120 mA
Average current	60 mA
Current limitation	Short-circuit-proof
Noise, 0 to 100 kHz	0.8 mV _{rms}
Voltage gain	10 ±0.1
Input impedance	100 kΩ
Interface and operation	
Interface / communication	USB, RS-232 (9-pin Sub-D connector, 9.6 – 115.2 kBaud), 24-bit A/D and 20-bit D/A
Piezo connector	LEMO ERA.00.250.CTL (.SR) / Sub-D special (.CR)
Sensor connection	LEMO EPL.0S.304.HLN (.SR) / Sub-D special (.CR)
Analog input	SMB
Sensor monitor output	SMB
Controller network	up to 12 channels, parallel
Command set	PI General Command Set (GCS)
User software	PIMikroMove
Software drivers	LabVIEW drivers, DLLs
Supported functionality	Wave table, 256 data points, external trigger, 16 macros
DC Offset	External potentiometer (not included), adds 0 to 10 V to Control In
Miscellaneous	
Operating temperature range	5 °C to 50 °C (above 40 °C, power derated)
Overtemp protection	Deactivation at 75 °C
Dimensions	7HP/3RU
Mass	0.6 kg
Operating voltage	12 to 30 V DC, stabilized
Current consumption, max.	2 A

E-727 Digital Multi-Channel Piezo Controller

For Nanopositioning Systems with Capacitive, Piezoresistive or Strain Gauge Sensors

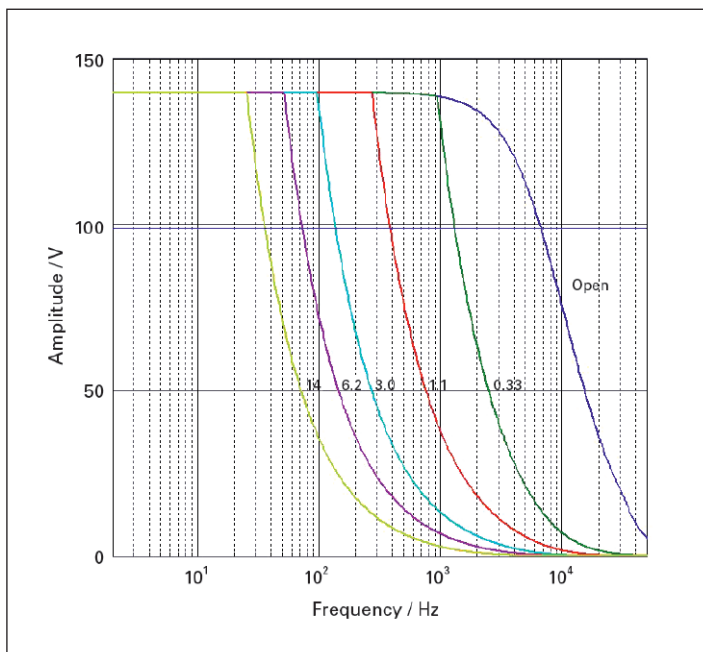

E-727: Operating limits (open-loop) with various capacitive loads, capacitance values in μF

- 20 kHz control bandwidth
- Interfaces: Ethernet, USB, RS-232, SPI
- Digital inputs and outputs
- Optional analog inputs and outputs
- Autoloading of calibration data from stage ID chip for interchangeability of controller and mechanics
- 4th order polynomial linearization for mechanics and electronics

>> Extensive Software Package

Technology Glossary page 240

	E-727.3CD E-727.3CDA	E-727.3SD E-727.3SDA E-727.4SD	E-727.3RD E-727.3RDA E-727.4RD	Unit	Tolerance
Function	Digital controller for multi-axis piezo nanopositioning systems with capacitive sensors .3CDA: Additional analog interfaces	Digital controller for multi-axis piezo nanopositioning systems with strain gauge sensors .3SDA: Additional analog interfaces	Digital controller for multi-axis piezo nanopositioning systems with piezo-resistive sensors .3RDA: Additional analog interfaces		
Axes	3	E-727.3x: 3 E-727.4x: 4	E-727.3x: 3 E-727.4x: 4		
Processor	DSP 32/64-bit, floating point, 375 MHz	DSP 32/64-bit, floating point, 375 MHz	DSP 32/64-bit, floating point, 375 MHz		
Sampling rate, servo control	20	20	20	kHz	
Sampling rate, sensor	100	100	100	kHz	
Sensor					
Servo characteristics	P-I, two notch filters Optional: Advanced piezo control	P-I, two notch filters Optional: Advanced piezo control	P-I, two notch filters Optional: Advanced piezo control		
Sensor type	Capacitive	Strain gauge sensors	Piezoresistive		
Sensor channels	3	4	4		
Sensor bandwidth (-3 dB)	10	10	10	kHz	max.
Sensor resolution (at 1 kHz oversampling)	20	20	20	Bit	
Amplifier					
Output voltage	-30 to 130	-30 to 130	-30 to 130	V	±3 V
Amplifier channels	4	4	4		
Peak output power per channel, max. 30 ms	28	28	28	W	max.
Average output power per channel	14	14	14	W	max.
Peak current per channel, max. 30 ms	180	180	180	mA	max.
Average output current per channel	75	75	75	mA	max.
Current limitation	Short-circuit proof	Short-circuit proof	Short-circuit proof		
Resolution DAC	20	20	20	Bit	
Amplifier bandwidth	6.5	6.5	6.5	kHz	
Interfaces and operation					
Interface / communication	Ethernet, USB, RS-232, serial SPI high-speed interface	Ethernet, USB, RS-232, serial SPI high-speed interface	Ethernet, USB, RS-232, serial SPI high-speed interface		
Piezo / sensor connection	Sub-D 25W3 (f)	Sub-D 37 (f)	Sub-D 37 (f)		
Analog inputs (only .3xDA)	Sub-D 15 (f) 4 inputs ±5V or ±10V 18-bit A/D converter	Sub-D 15 (f) 4 inputs ±5V or ±10V 18-bit A/D converter	Sub-D 15 (f) 4 inputs ±5V or ±10V 18-bit A/D converter		
Analog output (only .3xDA)	Sub-D 15 (f) ±10V 20-bit D/A converter	Sub-D 15 (f) ±10V 20-bit D/A converter	Sub-D 15 (f) ±10V 20-bit D/A converter		
Sensor monitor (only .3xDA)	Sub-D 15 (f) Sensor channels 1 to 3	Sub-D 15 (f) Sensor channels 1 to 3	Sub-D 15 (f) Sensor channels 1 to 3		

	E-727.3CD E-727.3CDA	E-727.3SD E-727.3SDA E-727.4SD	E-727.3RD E-727.3RDA E-727.4RD	Unit	Tolerance
Digital input/output	MDR14; 4 inputs, 4 outputs	MDR14; 4 inputs, 4 outputs	MDR14; 4 inputs, 4 outputs		
Command set	PI General Command Set (GCS)	PI General Command Set (GCS)	PI General Command Set (GCS)		
User software	PIMikroMove	PIMikroMove	PIMikroMove		
Software drivers	LabVIEW driver, shared libraries for Windows, and Linux	LabVIEW driver, shared libraries for Windows, and Linux	LabVIEW driver, shared libraries for Windows, and Linux		
Supported functions	Wave generator, data recorder, macros	Wave generator, data recorder, macros	Wave generator, data recorder, macros		
Display and indicators	LEDs for Power, Servo, Error, Overflow	LEDs for Power, Servo, Error, Overflow	LEDs for Power, Servo, Error, Overflow		
Linearization	4 th order polynomials, DDL (Dynamic Digital Linearization)	4 th order polynomials, DDL (Dynamic Digital Linearization)	4 th order polynomials, DDL (Dynamic Digital Linearization)		
Separate protective earth connection	Yes	Yes	Yes		
Miscellaneous					
Operating temperature range	5 to 40	5 to 40	5 to 40	°C	
Overheat protection	Max. 72 °C, deactivation of the voltage output	Max. 72 °C, deactivation of the voltage output	Max. 72 °C, deactivation of the voltage output		
Mass	2.4 to 2.6	2.4 to 2.6	2.4 to 2.6	kg	approx.
Power consumption	80	80	80	W	max.
Power consumption without load	24	24	24	W	max.
Operating voltage	24 V DC (external power supply in the scope of delivery)	24 V DC (external power supply in the scope of delivery)	24 V DC (external power supply in the scope of delivery)		
Dimensions	221 mm × 117 mm × 240 mm, incl. mounting rails	221 mm × 117 mm × 240 mm, incl. mounting rails	221 mm × 117 mm × 240 mm, incl. mounting rails		

E-727, dimensions in mm

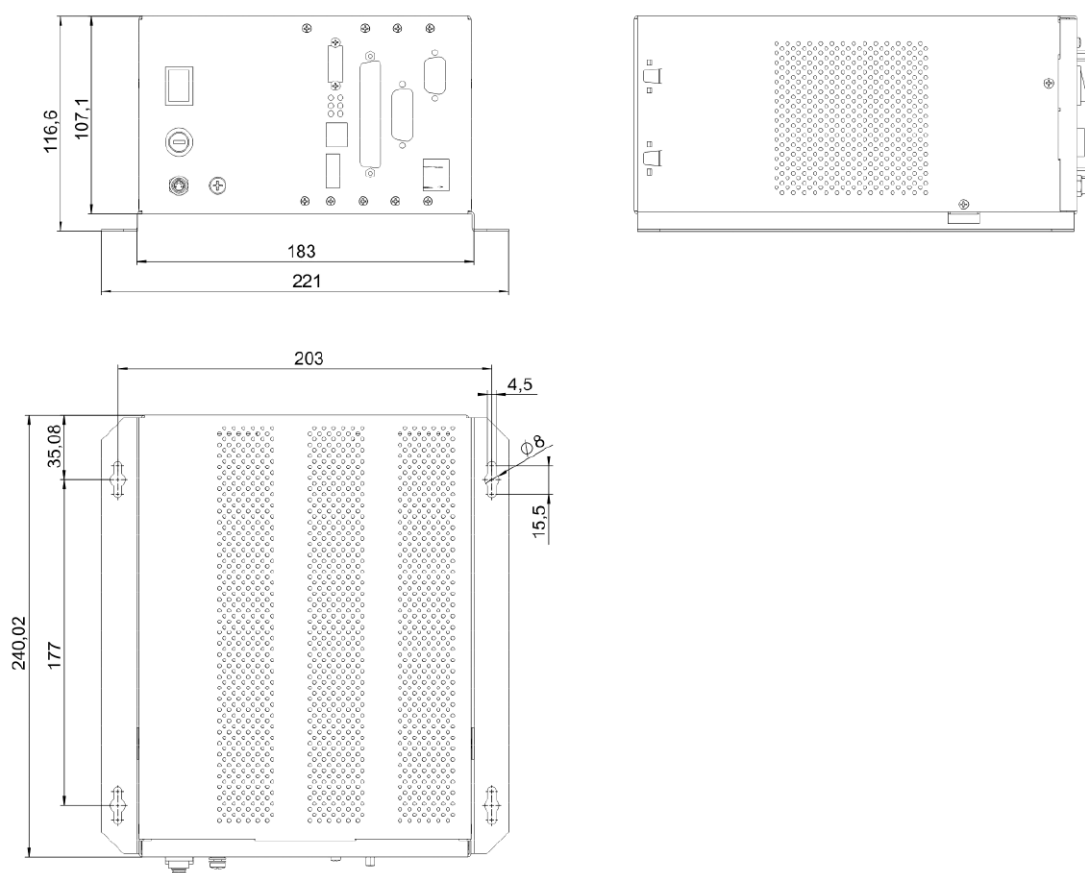

E-616 Controller for Multi-Axis Piezo Tip / Tilt Mirrors and Platforms

Flexible Multi-Channel OEM Electronics with Coordinate Transformation

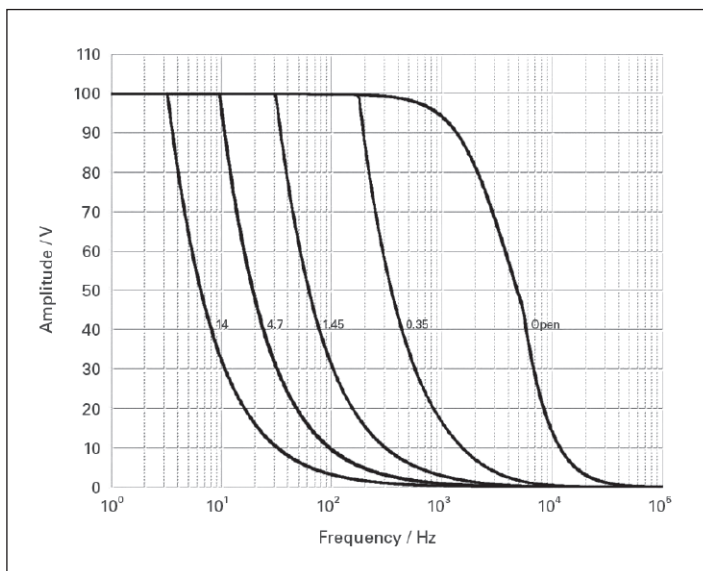

E-616: operating limits with various PZT loads (open-loop), capacitance is measured in μF

- Three integrated amplifiers provide up to 10 W peak power
- Closed-loop and open-loop versions
- Internal coordinate transformation simplifies control of parallel kinematics designs (tripod & differential drive)
- Compact and cost-effective design for OEMs or bench-top

	E-616.S0 / S0G	E-616.SS0 / SS0G	Unit
Function	E-616.S0: Controller for parallel-kinematics piezo tip / tilt mirror systems with strain gauge sensors, tripod design E-616.S0G: E-616.S0 with casing	E-616.SS0: Controller for parallel-kinematics piezo tip / tilt mirror systems with strain gauge sensors, differential design E-616.SS0G: E-616.SS0 with casing	
Tip / tilt axes	2	2	
Sensor			
Servo characteristics	P-I (analog), notch filter	P-I (analog), notch filter	
Sensor type	SGS	SGS	
Sensor channels	3	2	
External synchronization	200	200	kHzTTL
Amplifier			
Control input voltage	-2 to 12	-2 to 12	V
Output voltage	-30 to 130	-30 to 130; additional fixed voltage 100 V	V
Amplifier channels	3	3	
Peak output power per channel	10	10	W
Average output power per channel	5	5	W
Peak current per channel	100	100	mA
Average output current per channel	50	50	mA
Current limitation	Short-circuit-proof	Short-circuit-proof	
Voltage gain	10	10	
Amplifier bandwidth, small signal	3 kHz	3 kHz	
Ripple, noise, 0 to 100 kHz	<20 mV _{pp} <2 mV _{rms}	<20 mV _{pp} <2 mV _{rms}	
Amplifier resolution	<1	<1	mV
Interface and operation			
Piezo / sensor connector	Sub-D 25-pin	Sub-D 25-pin	
Analog input	E-616.S0: 32-pin DIN 41612 connector E-616.S0G: SMB connector	E-616.SS0: 32-pin DIN 41612 connector E-616.SS0G: SMB connector	
Sensor monitor signal	0 to 10 V for nominal displacement	0 to 10 V for nominal displacement	
Sensor monitor output	E-616.S0: 32-pin DIN 41612 connector E-616.S0G: 15-pin Sub-D connector	E-616.SS0: 32-pin DIN 41612 connector E-616.SS0G: 15-pin Sub-D connector	
Display	Power-LED and sensor OFL display	Power-LED and sensor OFL display	
Miscellaneous			
Operating temperature range	5 to 50	5 to 50	°C
Overheat protection	Max. 75 °C, deactivation of the piezo voltage output	Max. 75 °C, deactivation of the piezo voltage output	
Dimensions	E-616.S0: 186 mm × 128.4 mm × 10 HP E-616.S0G: 205 mm × 105 mm × 54.1 mm	E-616.SS0: 186 mm × 128.4 mm × 10 HP E-616.SS0G: 205 mm × 105 mm × 54.1 mm	
Mass	E-616.S0: 950 E-616.S0G: 1200	E-616.SS0: 950 E-616.SS0G: 1200	g
Operating voltage	E-616.S0: 12 to 30 E-616.S0G: 23 to 26	E-616.SS0: 12 to 30 E-616.SS0G: 23 to 26	VDC
Power consumption	30	30	W

E-536 PicoCube Piezo Controller

High Dynamics, High Resolution, for up to 3 Axes



- For P-363 PicoCube systems
- Peak power $3 \times 100 \text{ W}$
- Ultra-low noise
- High dynamics and high resolution
- Output voltage $\pm 250 \text{ V}$

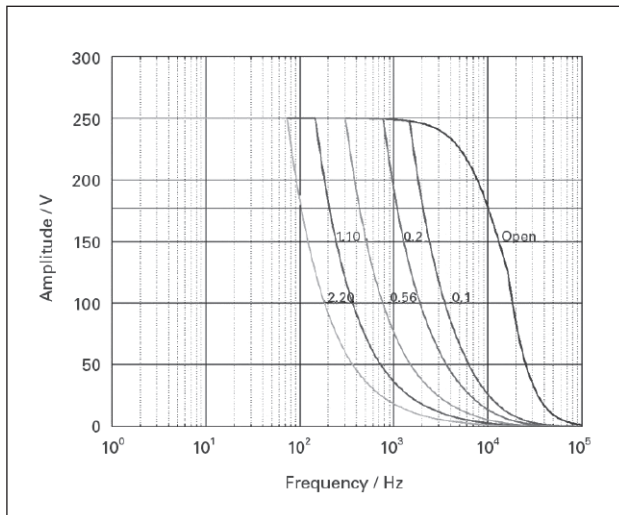

E-536.3x: operating limits with various PZT loads, capacitance is measured in μF

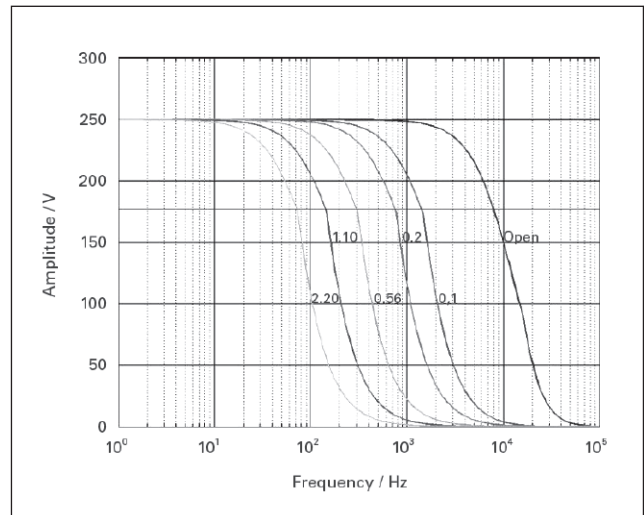

E-536.3xH: operating limits with various PZT loads, capacitance is measured in μF

	E-536.3C / E-536.30	E-536.3CH / E-536.30H
Function	Power amplifier & servo-controller for P-363 PicoCube	High-resolution power amplifier & servo-controller for P-363 PicoCube
Amplifier		
Output voltage	-250 to +250 V	-250 to +250 V
Amplifier channels	3	3
Average output power per channel	10 W, limited by temperature sensor	6 W, limited by temperature sensor
Peak output power per channel, <3 ms	100 W	50 W
Average current	30 mA	15 mA
Peak output current per channel, <3 ms	200 mA	100 mA
Amplifier bandwidth, small signal	10 kHz	2 kHz
Amplifier bandwidth, large signal, @ 100 nF	0.2 kHz	0.125 kHz
Ripple, noise 0 to 100 kHz	0.8 mV _{rms} <5 mV _{pp} (100 nF)	0.5 mV _{rms} <3 mV _{pp} (100 nF)
Current limitation	Short-circuit-proof	Short-circuit-proof
Voltage gain	50	50
Input impedance	100 kΩ	100 kΩ
Sensor*		
Servo characteristics	Analog proportional-integral (P-I) algorithm with notch filter	Analog proportional-integral (P-I) algorithm with notch filter
Sensor type	Capacitive sensors	Capacitive sensors
Sensor channels	3 / -	3 / -
Sensor bandwidth	1.5 kHz	1.5 kHz
Sensor monitor output	0 to +10 V	0 to +10 V
Interface and operation		
Piezo connector	LEMO EGG.0B.701.CJL.1173	LEMO EGG.0B.701.CJL.1173
Sensor target and probe sockets	LEMO EPL.00.250.NTD	LEMO EPL.00.250.NTD
Control input sockets	SMB	SMB
Sensor monitor socket	LEMO FGG.0B.306.CLAD56	LEMO FGG.0B.306.CLAD56
Control input voltage	Servo off: -5 to +5 V, Servo on: 0 to +10 V	Servo off: -5 to +5 V, Servo on: 0 to +10 V
DC-Offset	10-turn pot., adds 0 to +10 V to Control IN	10-turn pot., adds 0 to +10 V to Control IN
Miscellaneous		
Operating voltage	115 VAC / 50-60 Hz or 230 VAC / 50-60 Hz	115 VAC / 50-60 Hz or 230 VAC / 50-60 Hz
Mass	8.1 kg / 7.8 kg (with E-517 module)	8.1 kg / 7.8 kg (with E-517 module)
Dimensions	450 mm × 132 mm × 296 mm + handles	450 mm × 132 mm × 296 mm + handles

* only E-536.3Cx with capacitive sensors

Interfaces / communication: RS-232, TCP/IP and USB (with optional E-517 computer interface and display module only)

Operating temperature range: 5 to 50 °C (over 40 °C, max. av. power derated 10 %),

high-voltage output is automatically deactivated by internal temperature sensor if temperature is too high (75 °C max.)

Ask about custom designs!

E-712 Digital Piezo Controller

Modular System for up to 6 Axes for Highest Precision

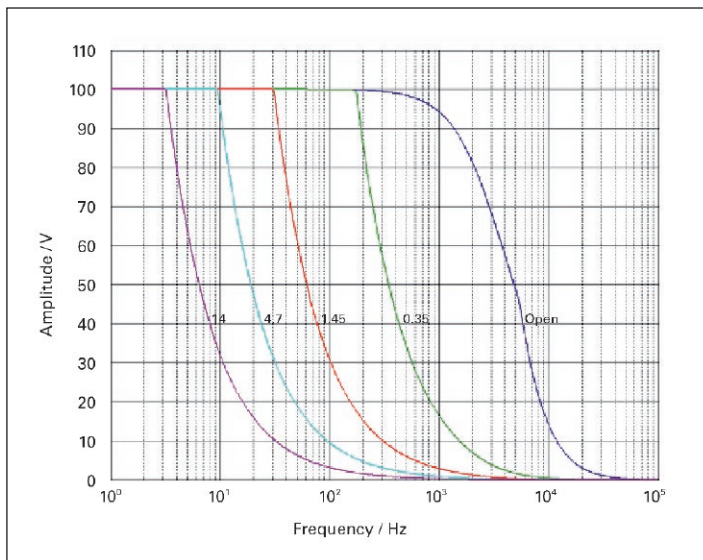

E-712.3CD: Operating limits with various PZT loads, capacitance values in µF

- Modular design for greatest flexibility in meeting custom requirements
- Up to 50 kHz servo update rate
- Highly stable 20-bit D/A converter
- Real-time operating system for excellent trajectory control
- Optimal linearity for highest accuracy
- Autoloading of calibration data from stage ID chip for interchangeability of controller and mechanics
- Flexible interfaces: TCP/IP, USB, RS-232
- Optional high-bandwidth analog inputs and outputs
- Extensive software package
- Integrated motion profile generator

>> Extensive software package
>> Linearization

Technology Glossary page 240

Preconfigured controllers

	E 712.3CD, E-712.3CDA	E 712.6CD, E-712.6CDA
Function	Modular digital controller for multi-axis piezo nanopositioning systems with capacitive sensors	Modular digital controller for multi-axis piezo nanopositioning systems with capacitive sensors
Axes	3	6
Processor	PC-based, 600 MHz, real-time operating system	PC-based, 600 MHz, real-time operating system
Sampling rate, servo control	50 kHz	20 kHz
Sampling rate, sensor	50 kHz	20 kHz
Sensor		
Controller type	P-I, two notch filters	P-I, two notch filters
Sensor type	Capacitive	Capacitive
Sensor channels	3	6
Sensor bandwidth (-3 dB)	10 kHz	10 kHz
Sensor resolution	18 (interpolated: 20) bits	18 (interpolated: 20) bits
External synchronization	Yes	Yes
Amplifier		
Output voltage	-30 to 135 V	-30 to 135 V
Amplifier channels	4	8
Peak output power / channel*	25 W	25 W
Average output power per channel	8 W	8 W
Current limitation	Short-circuit proof	Short-circuit proof
Resolution DAC	20 bits	20 bits
Temperature sensor	Yes	Yes
Interfaces and operation		
Communication interfaces	TCP/IP, USB, RS-232, SPI	TCP/IP, USB, RS-232, SPI
Piezo / sensor connection	Sub-D Mix 25W3	Sub-D Mix 25W3
Analog inputs	E-712.3CD: None E-712.3CDA: LEMO: 4 × ±10 V differential; bandwidth: max. 25 kHz; resolution: 18 bit; max. impedance: 250 Ohm	E-712.6CD: None E-712.6CDA: LEMO: 4 × ±10 V differential; bandwidth: max. 25 kHz; resolution: 18 bit; max. impedance: 250 Ohm
Analog outputs	E-712.3CD: None E-712.3CDA: LEMO: 4 × ±10 V differential; bandwidth: max. 25 kHz; resolution: 16 bit	E-712.6CD: None E-712.6CDA: LEMO: 4 × ±10 V differential; bandwidth: max. 25 kHz; resolution: 16 bit
Digital inputs/outputs	MDR20: 8 × TTL	MDR20: 8 × TTL
Command set	PI General Command Set (GCS)	PI General Command Set (GCS)
User software	PIMikroMove	PIMikroMove
Software drivers	LabVIEW drivers, DLLs	LabVIEW drivers, DLLs
Supported functions	Wave generator, trigger I/O, macros	Wave generator, trigger I/O, macros
Indicators	LEDs for OnTarget, Err, Power, OverTemp	LEDs for OnTarget, Err, Power, OverTemp
Linearization	4 th order polynomials, DDL option (Dynamic Digital Linearization)	4 th order polynomials, DDL option (Dynamic Digital Linearization)
Miscellaneous		
Operating temperature range	5 to 40 °C	5 to 40 °C
Overheat protection	Max. 75 °C, deactivation of the voltage output	Max. 75 °C, deactivation of the voltage output
Mass	E-712.3CD: 5.35 kg E-712.3CDA: 5.53 kg	E-712.6CD: 5.78 kg E-712.6CDA: 5.96 kg
Dimensions	9.5" housing, 236 mm × 132 mm × 296 mm + handles (47 mm length)	9.5" housing, 236 mm × 132 mm × 296 mm + handles (47 mm length)
Max. power consumption	225 W	225 W
Operating voltage	100 to 240 VAC, 50 to 60 Hz	100 to 240 VAC, 50 to 60 Hz

* The maximum output power is limited by the power supply of the housing and the number of available modules.

Available Modules

Housing types	E-712.R1	9.5" chassis with power supply for E-712 modular digital piezo controller system, for piezo voltages to 135 V, 3 to 6 axes
	E-712.R2	19" chassis with power supply for E-712 modular digital piezo controller system, for piezo voltages to ± 250 V, 3 to 6 axes
	E-712.R3	19" chassis with power supply for E-712 modular digital piezo controller system, for piezo voltages to 135 V, 3 to 6 axes
	E-712.R4	9.5" chassis with power supply for E-712 modular digital piezo controller system, for piezo voltages to ± 250 V, 3 to 6 axes
	E-712.R5	Universal chassis 19" 4 RU with CPCI Bus
Master modules	E-712.M1	Digital processor and interface module, TCP/IP, USB, RS-232, SPI
	E-712.N1	Digital PiezoWalk [®] processor and interface module, TCP/IP, USB, RS-232, SPI
Amplifiers	E-711.AL4P	High-power amplifier module for E-712 modular digital piezo controller system, 4 channels, 8 W, -30 V to +135 V
	E-711.AL41	High-power amplifier module for E-712 modular digital piezo controller system, 4 channels, 8 W, -30 V to +135 V, Sub-D 25W3 (f)
	E-711.AM4	Amplifier module for NEXLINE [®] , for E-712 modular digital piezo controller system, -250 V to +250 V
	E-711.AM5	Amplifier module for NEXLINE [®] , for E-712 modular digital piezo controller system, -250 V to +250 V, Sub-D 25 (f)
	E-711.AM6	Amplifier module for NEXLINE [®] , for E-712 modular digital piezo controller system, -250 V to +250 V, without external connector
	E-711.AM5A	Amplifier module for NEXLINE [®] , for E-712 modular digital piezo controller system, -250 V to +250 V, incremental Sin/Cos sensor input
	E-711.AM5B	Amplifier module for NEXLINE [®] , for E-712 modular digital piezo controller system, -250 V to +250 V, absolute encoder
	E-711.AN4	NEXACT [®] amplifier module, for E-712 modular digital piezo controller system
	E-711.AN40	NEXACT [®] amplifier module, for E-712 modular digital piezo controller system, without external connector
	E-711.C82	DC motor driver for E-712 modular digital piezo controller system, 2 axes
I/O modules: Sensor modules	E-711.SA3	Module for incremental sensors, 3 channels, for E-712 modular digital piezo controller system
	E-711.SA6	Module for incremental sensors, 6 channels, for E-712 modular digital piezo controller system
	E-711.SS3	Module for strain gauge sensors, 3 channels, for E-712 modular digital piezo controller system
	E-711.SC3H	Module for capacitive sensors, 3 channels, for E-712 modular digital piezo controller system
	E-711.SE3	Module for PISeca capacitive 1-electrode sensors, 3 channels, for E-712 modular digital piezo controller system
I/O modules: Sensor signal transmission	E-711.0CT	Digital sensor signal transmission, 3 channels, capacitive sensors, for E-712 modular digital piezo controller system
	E-711.0CT0	Digital sensor signal transmission, 3 channels, capacitive sensors, for E-712 modular digital piezo controller system, without cable
	E-711.0ET	Digital sensor signal transmission, 3 channels, PISeca sensors, for E-712 modular digital piezo controller system, with 10 m cable
	E-711.0ET0	Digital sensor signal transmission, 3 channels, PISeca sensors, for E-712 modular digital piezo controller system, without cable
	E-711.0ATS	Sensor box for digital sensor signal transmission, 3 channels, incremental or absolute sensors with BiSS interface, for E-712 modular digital piezo controller system
I/O modules: Interface modules	E-711.IA4	Analog interface module for E-712 modular digital piezo controller system, 4 inputs and outputs
	E-711.IP	PIO interface module for E-712 modular digital piezo controller system
	E-711.iS3	SPI interface module for E-712 modular digital piezo controller system, 3 channels
	E-711.iS6	SPI interface module for E-712 modular digital piezo controller system, 6 channels
Accessories	E-711.SAP	Sensor signal distributor for E-712 modular digital piezo controller system, 3 channels, for PIONe incremental sensors
	E-711.SAH	Sensor signal distributor for E-712 modular digital piezo controller system, 3 channels, for Heidenhain incremental sensors
	E-711.SAN	Sensor signal distributor for E-712 modular digital piezo controller system, 3 channels, for Numerik Jena incremental sensors
	E-711.SAX	Cable between digital piezo controller and sensor signal distributor, HD Sub-D 26
	E-711.SAX1	Cable between digital piezo controller and sensor signal distributor, HD Sub-D 26, 3 m
	E-711.SAX2	Cable between digital piezo controller and sensor signal distributor, HD Sub-D 26, 5 m
	E-711.SAX5	Cable between digital piezo controller and sensor signal distributor, HD Sub-D 26, 15 m

For system configuration consultancy, contact your PI representative.

Housing types and modules

Housing types	E-712.R1 / E-712.R3	E-712.R2 / E-712.R4	E-712.R5
Function	Chassis with power supply	Chassis with power supply	Chassis with cPCI bus
Piezo voltage range	-30 to 135 V	-250 to 250 V	up to -250 to 250 V
Channels	3 to 6	3 to 6	up to 12
Dimensions	E-712.R1: 9.5" (236 mm × 132 mm × 296 mm + handles (47 mm length)) E-712.R3: 19" (450 mm × 132 mm × 296 mm + handles (47 mm length))	E-712.R2: 19" (450 mm × 132 mm × 296 mm + handles (47 mm length)) E-712.R4: 9.5" (236 mm × 132 mm × 296 mm + handles (47 mm length))	19" (450 mm × 177 mm × 375 mm + handles (47 mm length))
Mass	.R1: 4.16 kg / .R3: 6.7 kg	.R2: 6.7 kg / .R4: 4.16 kg	4.4 kg
Operating voltage	100 to 240 VAC, 50 – 60 Hz	100 to 240 VAC, 50 – 60 Hz	100 to 240 VAC, 50 – 60 Hz
Line power fuses	2 × T1.6AH, 250 V*	2 × T1.6AH, 250 V*	2 × T3.15AH, 250 V*
Current consumption, max.	225 VA	225 VA	450 VA
Max. output power	100 W	100 W	200 W

* unless stated otherwise on the type plate of the housing

Master modules	E-712.M1	E-712.N1
Function	Digital processor and interface module	Digital processor and interface module
Supported drive type	Piezo nanopositioning systems (except PiezoWalk® systems)	Piezo nanopositioning systems, PiezoWalk® systems
Axes	up to 16	up to 16
Sampling rate, servo control	max. 50 kHz	max. 50 kHz
Sampling rate, sensor	max. 50 kHz	max. 50 kHz
Communication interfaces	TCP/IP, USB, RS-232, SPI	TCP/IP, USB, RS-232, SPI

Amplifiers	E-711.AL4P / E-711.AL41	E-711.AM4 / E-711.AM5 / E-711.AM6 / E-711.AM5A / E-711.AM5B	E-711.AN4 / E-711.AN40	E-711.C82
Function	Amplifier module	Amplifier module	Amplifier module	DC motor driver
Drive type	Piezo actuators	NEXLINE®	NEXACT®	DC motors
Channels	4	4	4	2
Average output power per channel	8 W	15 W	4 W	30 W
Output voltage	-30 to 135 V	-250 to 250 V	-10 to 45 V	0 to 24 V
Sensor input	-	E-711.AMx: – E-711.AM5A: incremental, sin/cos E-711.AM5B: absolute, BiSS	-	Incremental: A/B, sin/cos Absolute: BiSS
Connection	E-711.AL4P: via E-711.SS3 or E-711.SC3H E-711.AL41: Sub-D 25W3	E-711.AM4: Sub-D 24W7 E-711.AM5: Sub-D 25 (f) E-711.AM6: via HD Sub-D 50 (f) of the E-712.R5 chassis E-711.AM5A / .AM5B: Sub-D 25 (f)	E-711.AN4: Sub-D 15 (f) E-711.AN40: via HD Sub-D 78 (f) of the E-712.R5 chassis	Sub-D 15 (f)

Housing types and modules

I/O: Sensor modules	E-711.SA3 / E-711.SA6	E-711.SS3	E-711.SC3H / E-711.SE3
Function	Module for incremental sensors	Module for strain gauge sensors	Module for capacitive sensors
Sensor type	Incremental sensors (analog sin/cos, V_{pp})	Strain gauge sensors, temperature sensors	E-711.SCH3: capacitive 2-electrode sensors E-711.SE3: PISeca capacitive 1-electrode sensors
Channels	3 / 6	4	3
Sensor connection	1 x / 2 x HD Sub-D 26 (m)	Sub-D 37 (f)	Sub-D 25W3 / 3 x Lemo triaxial socket
Sensor bandwidth	300 kHz	10 kHz	10 kHz / 5 kHz
A/D resolution	Interpolation factor selectable	18 bits (interpolated)	18 bits (interpolated: 20 bits)

I/O: Sensor signal transmission	E-711.OCT / E-711.OCT0	E-711.OET / E-711.OET0	E-711.OATS
Function	Set for digital sensor signal transmission, consisting of: Interface module, sensor box with signal processing electronics; E-711.OCT additionally with connecting cables	Set for digital sensor signal transmission, consisting of: Interface module, sensor box with signal processing electronics; E-711.OET additionally with sensor cable	Sensor box for digital sensor signal transmission
Sensor type	Capacitive 2-electrode sensors	PISeca capacitive 1-electrode sensors	Absolute-measuring or incremental encoders via 32-bit BISS interface
Channels	3	3	8
Sensor connection	Sub-D 25W3	3 x Lemo triaxial socket	8 x Sub-D 9 (f)
Sensor bandwidth	10 kHz	max. 5 kHz	N/A
A/D resolution	18 bits (interpolated: 20 bits)	20 bits interpolated	N/A

I/O: Interface modules	E-711.IA4	E-711.IP	E-711.iS3 / E-711.iS6
Function	Analog interface module	Parallel input/output interface module for fast data exchange	SPI master interface module
Input/output	4 x analog input 4 x analog output	Parallel input/output	SPI
Channels	4	15	3 / 6
Resolution	Input: 18 bit Output: 16 bit	32 bits	32 bits
Bandwidth	Input: max. 25 kHz Output: max. 12 kHz	N/A	N/A
Connection	8 x LEMO EPG.00.302.NLN	HD Sub-D 62 (f) for connection to a digital interface card of the PC via the included cable (K040B0121)	Display port

9.5" housing types E-712.R1 and .R4, dimensions in mm

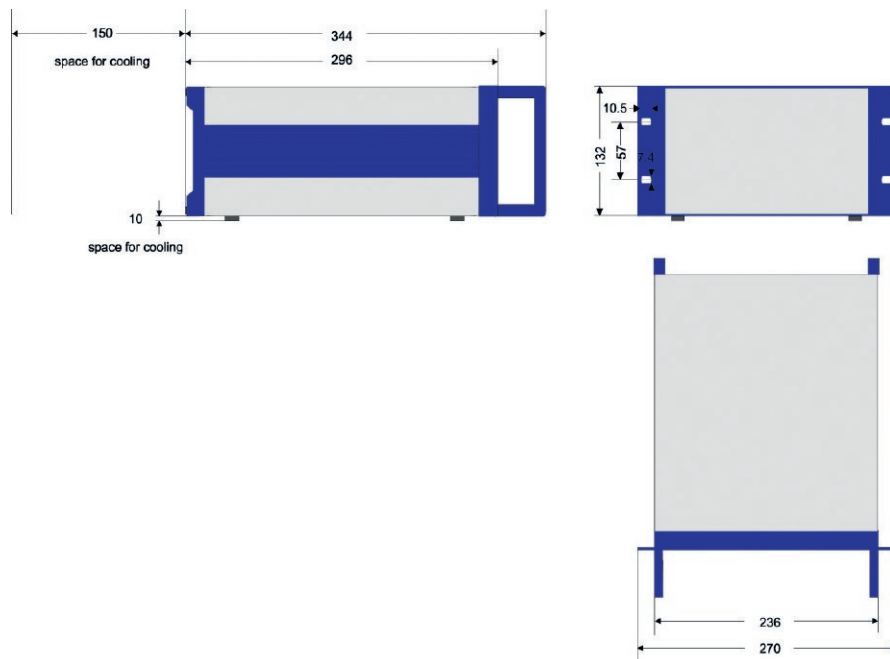

19" housing types E-712.R2 and .R3, dimensions in mm

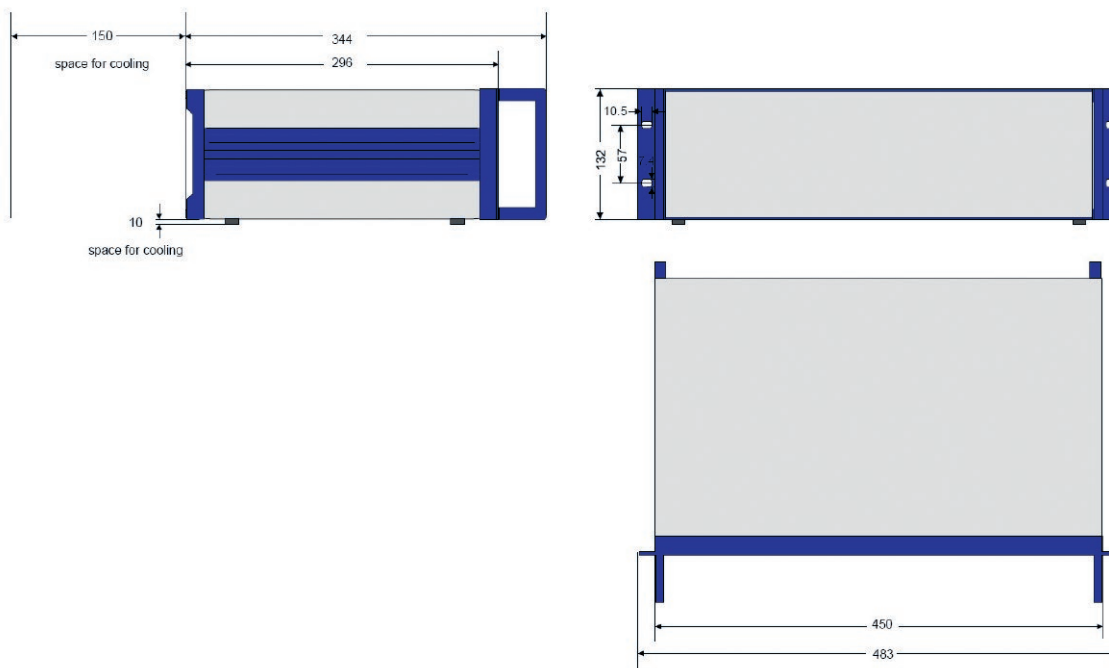

E-500 Modular Piezo Controller

Flexible System for Piezo Actuators and Nanopositioners



- Up to 3 axes, custom systems up to 12 axes and more
- Piezo amplifier modules for low-voltage and high-voltage, 14 to 400 W peak power
- Choice of position servo control modules for capacitive and SGS sensors, 1 to 3 channels
- Choice of PC interface / display modules
- TCP/IP, USB and RS-232 interfaces
- 19" and 9.5" chassis

Modular motion control system for more flexibility

The modular E-500 system is configurable and supports piezo actuators, piezo-based tip / tilt platforms, and positioning systems with up to three motion axes. The flexibility of the E-500 system allows mixed operation with different single-channel amplifier or sensor modules. The modularity also allows suitable control for customized systems.

Sensor modules

PI uses capacitive or strain sensors in its positioning systems according to the accuracy requirements. The E-500 supports operation of up to three axes with single- to three-channel sensor modules.

Interface and function module for piezo-based positioning systems

It is possible to control the modular, analog, closed-loop E-500 motion control system digitally via the three-channel E-518 interface module. Furthermore, the E-518 also includes a wide range of digital functions such as macro programming, wave generator or data recorder.

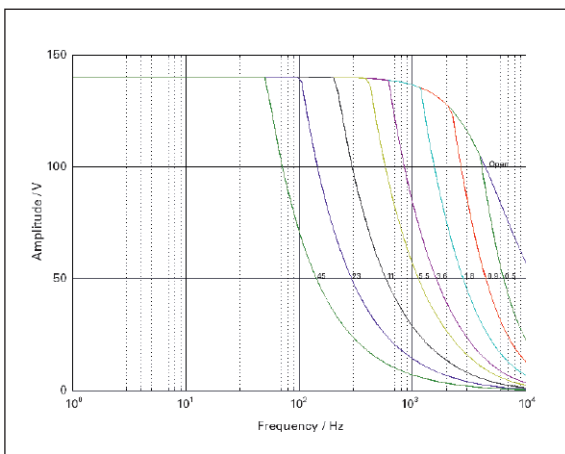

E-504: Operating limits (open-loop) with various PZT loads, capacitance values in μF

- >> Energy Recovery
- >> Extensive software package
- >> Linearization

Technology Glossary page 240

Available Modules

E-500.00	19" housing for modular piezo controller system, 1 to 3 Channels
E-501.00	9.5" housing for modular piezo controller system, 1 to 3 Channels
E-500.ACD	LabVIEW Driver Set for Analog Controllers
E-500.HCD	HyperBit Functionality for Enhanced System Resolution(Supports Certain D/A Boards)
E-503.00	Piezo Amplifier Module, -30 to 130 V, 3 Channels
E-503.00S	Piezo Amplifier Module, -30 to 130 V, 2 Channels. Customized version, modified for S-330, S-340, S-334 tip / tilt mirror systems, with a fixed voltage of +100 V, two variable voltages
E-504.00F	High-power-Piezo Amplifier Module, 1 Channel, 280 W Peak Power, 100 W Average Power, -30 to 130 V
E-505.00	Piezo Amplifier Module, 2 A, -30 to 130 V, 1 Channel
E-505.10	Piezo Amplifier Module for switching applications, 10 A, -30 to 130 V, 1 Channel
E-505.00S	Offset Voltage Source for tip / tilt Platforms, 100 V fixed voltage
E-506.10	High Linearity Piezo Amplifier Module, 30 W Average Output Power, -30 to 130 V, 1 Channel
E-508.00	HVPZT piezo amplifier module, 3 to 1100 V, 1 channel
E-508.OE	HVPZT piezo amplifier module, OEM, 400 mA peak current
E-509.C1A	Sensor / Piezo Servo-Control Module, capacitive sensor, 1 Channel
E-509.C2A	Sensor / Piezo Servo-Control Module, capacitive sensors, 2 Channels
E-509.C3A	Sensor / Piezo Servo-Control Module, capacitive sensors, 3 Channels
E-509.S1	Sensor / Piezo Servo-Control Module, SGS Sensor, 1 Channel
E-509.S3	Sensor / Piezo Servo-Control Module, Strain Gauge Sensors, 3 Channels
E-509.E3	PISeca Sensor / Piezo Servo-Control Module for capacitive single-electrode sensors, 3 axes
E-509.E03	PISeca Modular Evaluation electronics for single-electrode capacitive sensors, 3 axes
E-515.01	Display Module for Piezo Voltage and Displacement, 1 Channel
E-515.03	Display module for piezo voltage and displacement, 3 Channels
E-518.I3	Interface module, 3 Channels, TCP/IP, USB and RS-232 interfaces

For system configuration consultancy, contact your PI representative.

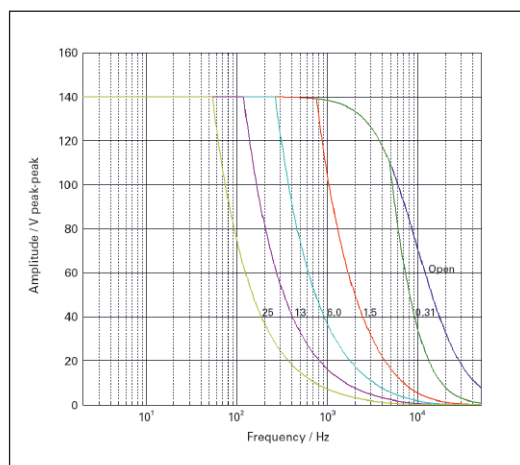

E-505: Operating limits (open-loop) with various PZT loads, capacitance values in μF

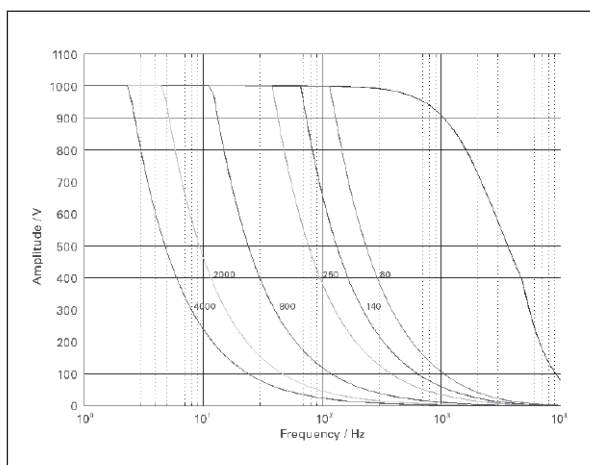

E-508: Operating limits (open-loop) with various PZT loads, capacitance values in nF

Housing

	E-500.00	E-501.00
Function	19"-chassis for piezo controller system: Amplifier modules, sensor- / servo-control modules, interface / display modules	9.5"-chassis for piezo controller system: Amplifier modules, sensor- / servo-control modules, interface / display modules
Channels	1, 2, 3 (up to 3 amplifier modules)	1, 3 (1 amplifier module)
Dimensions	450 mm × 132 mm × 296 mm + handles	236 mm × 132 mm × 296 mm + handles
Operating voltage	90 – 264 VAC, 50 – 60 Hz	90 – 120 / 220 – 264 VAC, 50-60 Hz
Max. power consumption	180 W	80 W

Piezo Amplifier Modules for Static and Low-Dynamics Operation

	E-503.00 / E-503.00S	E-505.00	E-505.00S
Function	Power amplifier	Power amplifier	Offset voltage supply for tip / tilt systems
Channels	3 / 2	1	1
Amplifier			
Control input voltage range	-2 to +12 V	-2 to +12 V	-
Output voltage	-30 to 130 V (E-503.00S: one additional fixed voltage of 100 V)	-30 to +130 V	100 V
Peak current per channel (<5 ms)	140 mA	2 A (<3 ms)	2 A
Average current per channel (> 5 ms)	40 mA	215 mA	300 mA
Current limitation	Short-circuit-proof	Short-circuit-proof	Short-circuit-proof
Voltage gain	10 ±0.1	10 ±0.1	-
Input impedance	100 kΩ / 1 nF	1 MΩ / 1 nF	-
Ripple, noise, 0 to 10 kHz		<0.6 mV _{rms}	<0.7 mV _{rms}
Internal base load			
Amplifier resolution			
Output impedance			
Interfaces and operation			
Piezo connector (voltage output)	LEMO ERA.00.250.CTL	LEMO ERA.00.250.CTL	LEMO ERA.00.250.CTL
Analog input / control in	BNC	BNC	-
DC Offset	10-turn pot., adds 0 to 10 V to Control In	10-turn pot., adds 0 to 10 V to Control input	-
Miscellaneous			
Operating temperature range	5 to 50 °C	5 to 50 °C	5 to 50 °C
Overtemp protection	Deactivation at 85 °C	Deactivation at 85 °C	Deactivation at 85 °C
Dimensions	14HP/3RU	14HP/3RU	14HP/3RU
Mass	0.9 kg	0.9 kg	0.9 kg
Max. power consumption	40 W	55 W	55 W

Ask about custom designs!

Piezo Amplifier Modules for High-Dynamics Operation

	E-504.00F	E-505.10	E-506.10	E-508.00	E-508.OE
Function	Power amplifier with energy recovery*	Power amplifier for switching applications*	Linearized amplifier module, charge-controlled	Power amplifier for PICA high- voltage PZTs	Power amplifier for PICA high- voltage PZTs
Channels	1	1	1	1	1

	E-504.00F	E-505.10	E-506.10	E-508.00	E-508.OE
Amplifier					
Control input voltage range	-2 to 12 V	-2 to +12 V	-2 to 12 V	Servo off: $\pm 1/100$ of selected output voltage range Servo on: 0 to 10 V	Servo off: $\pm 1/100$ of selected output voltage range Servo on: 0 to 10 V
Output voltage	-20 to 120 V	-30 to +130 V	-30 to 130 V	3 to +1100 V (default) Adjustable: -260 to +780 V -550 to +550 V +260 to -780 V -3 to -1100 V	3 to +1100 V (default) Optional: -260 to +780 V -550 to +550 V +260 to -780 V -3 to -1100 V
Peak output power	200 W			50 W (< 5 ms)	400 W (< 5 ms)
Average output power	100 W at full voltage range			13 W	13 W
Peak current per channel (<5 ms)	2000 mA	10 A (<200 μ s)	2 A (<2.5 ms)	50 mA	400 mA
Average current per channel (>5 ms)	1000 mA	215 mA	215 mA	12 mA	12 mA
Current limitation	Short-circuit-proof	Short-circuit-proof	Short-circuit-proof	Short-circuit proof	Short-circuit proof
Amplifier bandwidth, small signal				6 kHz	10 kHz
Amplifier bandwidth, large signal				50 Hz (200 nF)	50 Hz (200 nF)
Voltage gain	10 \pm 0.1	10 \pm 0.1		+100 \pm 1, -100 \pm 1 (selectable)	+100 \pm 1, -100 \pm 1 (selectable)
Input impedance		1 M Ω / 1 nF	1 M Ω / 1 nF	100 k Ω	100 k Ω
Ripple, noise, 0 to 10 kHz	<2 mV _{rms} <10 mV _{pp}	1.0 mV _{rms}	<0.6 mV _{rms}	5 mV _{rms} 50 mV _{pp} (100 nF)	20 mV _{rms} 200 mV _{pp} (100 nF)
Internal base load	1.5 μ F	-	-		
Reference capacitance (adjustable)			1 to 280 μ F		
Suggested capacitive load			>0.3 μ F		
Amplifier resolution	<1 mV				
Output impedance	0.5 Ω				
Interfaces and operation					
Piezo connector (voltage output)	LEMO ERA.00.250.CTL	LEMO ERA.00.250.CTL	LEMO 2-pin EGG.0B.302.CLL	LEMO EGG.0B.701. CJL.1173	LEMO EGG.0B.701. CJL.1173
Analog input / control in	SMB	BNC	BNC	BNC	SMB
DC Offset	10-turn pot., adds 0 to 10 V to Control In	10-turn pot., adds 0 to 10 V to Control input	10-turn pot., adds 0 to 10 V to Control In	10-turn pot., adds 0 to 10 V to Control In	-
Piezo temperature sensor (input)	-	-	PT 1000; LEMO socket; automatic deactivation of high voltage output at max. 150 °C		
Miscellaneous					
Operating temperature range	0 to 40 °C	5 to 50 °C	5 to 50 °C	5 to 50 °C (above 40 °C, power derated)	5 to 50 °C (above 40 °C, power derated)
Overtemp protection		Deactivation at 85 °C	Deactivation at 85 °C		
Dimensions	14 HP / 3 RU	14HP/3RU	14 HP / 3 RU	14 HP / 3 RU	14 HP / 3 RU
Mass	0.9 kg	0.9 kg	0.9 kg	0.75 kg	0.75 kg
Max. power consumption		55 W	55 W		

* For piezo actuators with special high-current layout

Signal Conditioner / Piezo Servo Modules

	E-509.C1A / E-509.C2A / E-509.C3A	E-509.S1 / E-509.S3	E-509.E03	E-509.E3
Function	Sensor / position servo-control modules for piezo-driven systems	Sensor / position servo-control modules for piezo-driven systems	Sensor evaluation electronics for PISeca	Sensor / servo controller module for PISeca
Channels	1 / 2 / 3	1 / 3	3	3
Supported functions	ILS (Internal Linearized System)	ILS (Internal Linearized System)	ILS (Internal Linearized System)	ILS (Internal Linearized System)
Sensor				
Servo characteristics	P-I (analog), notch filter	P-I (analog), notch filter	–	Analog P-I and notch filter
Sensor type	Capacitive	SGS	PISeca single electrode, capacitive	PISeca single electrode, capacitive
Sensor channels	1 / 2 / 3	1 / 3	3	3
Sensor bandwidth	0.3 to 3 kHz (jumper selectable); to 10 kHz on request	0.3; 1; 3 kHz	0.3 to 10 kHz (adjustable)	0.3 to 10 kHz (adjustable)
Extension factor for measurement range*			1 (default), 2 / 2.5 / 5 (optional)	1 (default), 2 / 2.5 / 5 (optional)
Noise factor	0.115 ppm/ $\sqrt{\text{Hz}}$	–	0.14 ppm/ $\sqrt{\text{Hz}}$ **	0.14 ppm/ $\sqrt{\text{Hz}}$ **
External synchronization			3 synchronized channels	3 synchronized channels
Thermal drift	<0.3 mV/°C	<3 mV/°C	<1 mV/°C	<1 mV/°C
Linearity error	<0.05 %	<0.2 %	<0.1 % (<0.2 % for D-510.020) **	<0.1 % **
Static resolution***			<0.001 % of the measurement range (RMS)	<0.001 % of the measurement range (RMS)
Dynamic resolution***			<0.002 % of the measurement range (RMS)	<0.002 % of the measurement range (RMS)
Sensor monitor output	0 – 10 V	0 – 10 V		
Sensor monitor socket	LEMO 6-pin FGG.0B.306.CLAD56	BNC (1-ch.) / 3-pin LEMO (3-ch.)		
Output voltage			0 to 10 V –5 to 5 V, –10 to 0 V (selectable)	0 to 10 V –5 to 5 V, –10 to 0 V (selectable)
Interface and operation				
Sensor connection	LEMO EPL.00.250.NTD	LEMO ERA.0S.304.CLL	3 × LEMO ECP.00.650. NLL.543 triaxial socket	3 × LEMO ECP.00.650. NLL.543 triaxial socket
Signal output			LEMO 6-pin FGG.0B.306.CLAD56	LEMO 6-pin FGG.0B.306.CLAD56
Display	Overflow LED	Overflow LED		
Target ground connector			3 × banana jack, 4 mm	3 × banana jack, 4 mm
Miscellaneous				
Operating temperature range	5 to 50 °C	5 to 50 °C	5 to 40 °C	5 to 40 °C
Dimensions	7HP/3RU	7HP/3RU	7HP/3RU	7HP/3RU
Mass	0.35 kg	0.35 kg	0.3 kg	0.3 kg
Max. power consumption	4 to 8 W	4 to 8 W		

* Extension factors refer to the nominal measurement range of the respective D-510 sensor head, to be specified with the order.

** In the nominal measurement range

*** Bandwidth: Static 300 Hz, dynamic 3 kHz

Interface / Display Modules

	E-518.i3	E-515.01	E-515.03
Function	Digital interface module for the E-500 system (E-500, E-470, E-481, E-482)	Display module for piezo voltage and positioning	Display module for piezo voltage and positioning
Channels	3	1	3
Processor	DSP 376 MHz		
Sampling rate, sensor	200 kHz		
Servo control rate	25 kHz		
Sensor resolution	ADC: 20 bits, oversampling + filter		
Voltage resolution	DAC: 20 bits, oversampling + filter, 16 bit @ 1 MHz		
Interfaces and operation			
Interface / Communication	Ethernet (TCP/IP) USB, RS-232		
I/O ports	3 digital inputs 3 digital outputs 3.3 V MDR14 connector		
Command set	PI General Command Set (GCS)		
User software	PIMikroMove		
Software drivers	LabVIEW driver, libraries for Windows (DLL) and Linux		
Supported functions	Wave generator, data recorder, macro programming		
Display linearity		0.1 %	0.1 %
Display		1 × 3½ digits	3 × 3½ digits
Miscellaneous			
Operating temperature range	5 to 50 °C		
Dimensions	14HP / 3RU	21HP / 3RU	21HP / 3RU
Mass	0.26 kg	0.3 kg	0.3 kg

E-651 / E-614 Piezo Amplifier / Servo Controller

For Closed-Loop Multilayer Bending Actuators



- For closed-loop multilayer piezo bending actuators
- Bench-top and OEM-board versions
- 1- and 2-channel versions

	E-651.1S	E-651.2S	Unit
Function	Piezo amplifier & servo controller for multilayer bending actuators, bench-top	Piezo amplifier & servo controller for multilayer bending actuators, bench-top	
Channels	1	2	
Sensor			
Servo characteristics	P-I (analog)	P-I (analog)	
Sensor type	SGS	SGS	
Sensor bandwidth	Low-pass filter cut-off frequency: 100 Hz / 5 kHz selectable	Low-pass filter cut-off frequency: 100 Hz / 5 kHz selectable	
Amplifier			
Control input voltage	-5 to 5	-5 to 5	V
Min. output voltage	0 to 60, plus fixed reference voltage of 60 V	0 to 60, plus fixed reference voltage of 60 V	V
Peak output current per channel	36	36	mA
Average output current per channel	18	18	mA
Current limitation	Short-circuit-proof	Short-circuit-proof	
Voltage gain	6	6	
Input impedance	100	100	kΩ
Interface and operation			
Piezo / sensor connection	LEMO EPG.0B.307.HLN	LEMO EPG.0B.307.HLN	
Analog input / control in	BNC	BNC	
Sensor monitor output	0 to 10 for nominal displacement	0 to 10 for nominal displacement	V
Sensor monitor socket	BNC	BNC	
Miscellaneous			
Operating temperature range	5 to 50	5 to 50	°C
Overtemp protection	Deactivation at 75 °C	Deactivation at 75 °C	
Dimensions	125 mm × 90 mm × 265 mm	125 mm × 90 mm × 265 mm	
Mass	1.36	1.45	kg
Operating voltage	14 to 16 V DC (C-890.PS power supply included)	14 to 16 V DC (C-890.PS power supply included)	
Power consumption	15	15	W

E-617 High-Power Piezo Amplifier

Top-Hat & OEM Modules with Energy Recovery for High-Dynamics 24/7 Operation



- Peak power to 280 W
- High currents to 2000 mA
- Low power consumption
- OEM module and top-hat-rail versions

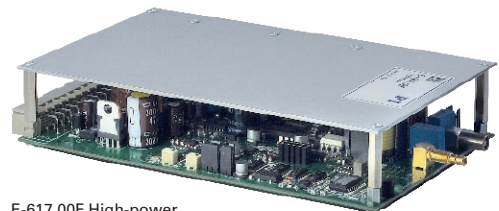

E-617.00F High-power OEM driver module

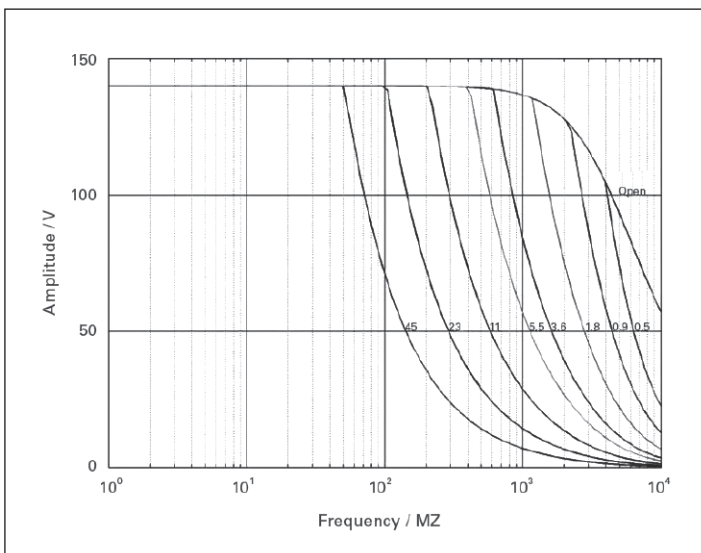

E-617: operating limits with various PZT loads (open-loop), capacitance is measured in μF

>> Energy recovery operating principle

Technology Glossary page 240

	E-617001	E-61700F	Unit
Function	High-power Piezo Amplifier with Energy Recovery, 1 Channel, -30 to 130 V, for Top-Hat-Rail Mounting	High-power Piezo Amplifier with Energy Recovery, 1 Channel, -30 to 130 V	
Amplifier			
Control input voltage	-2 to 12	-2 to 12	V
Output voltage	-30 to 130	-30 to 130	V
Peak output power, <5 ms	280	280	W
Average output power (>5 ms)	Equivalent to 100 W reactive power	Equivalent to 100 W reactive power	
Peak current, <5 ms	2000	2000	mA
Average output current (>5 ms)	1000	1000	mA
Current limitation	Short-circuit-proof	Short-circuit-proof	
Voltage gain	10 ±0.1	10 ±0.1	
Amplifier bandwidth, small signal	3.5	3.5	kHz
Ripple, noise, 0 to 10 kHz	<2 mV _{rms} <10 mV _{pp}	<2 mV _{rms} <10 mV _{pp}	
Capacitive base load (internal)	1.0	1.0	μF
Suggested capacitive load	>3	>3	μF
Output impedance	0.5	0.5	Ω
Amplifier resolution	<1	<1	mV
Amplifier classification	Class D (switching amp), 100 kHz	Class D (switching amp), 100 kHz	
Input impedance	100	100	kΩ
Interface and operation			
Piezo connector (voltage output)	Phoenix-plug connector MINI-COMBICON 3-pin MC1.5 / 3-ST-3.81	LEMO ERA.00.250.CTL (front); DIN 41612 32-pin (rear)	
Analog input / control in	Phoenix-plug connector MINI-COMBICON 6-pin IMC1.5 / 6-ST-3.81	SMB	
DC offset	External potentiometer (not included), adds 0 to 10 V to Control In	External potentiometer (not included), adds 0 to 10 V to Control In	
Miscellaneous			
Operating temperature range	5 to 50 (above 40 °C, power derated)	5 to 50 (above 40 °C, power derated)	°C
Dimensions	205 mm × 105 mm × 60 mm	7 HP / 3 RU	
Mass	1	0.35	kg
Operating voltage	23 to 26 VDC, stabilized, on Phoenix plug MINI-COMBICON 3-pin IMC1.5 / 3-ST-3.81	23 to 26 VDC, stabilized, on 32-pin DIN 41612 connector	
Max. power consumption	<30	<30	W

E-618 High-Power Piezo Amplifier / Servo Controller

High Currents, High Dynamics

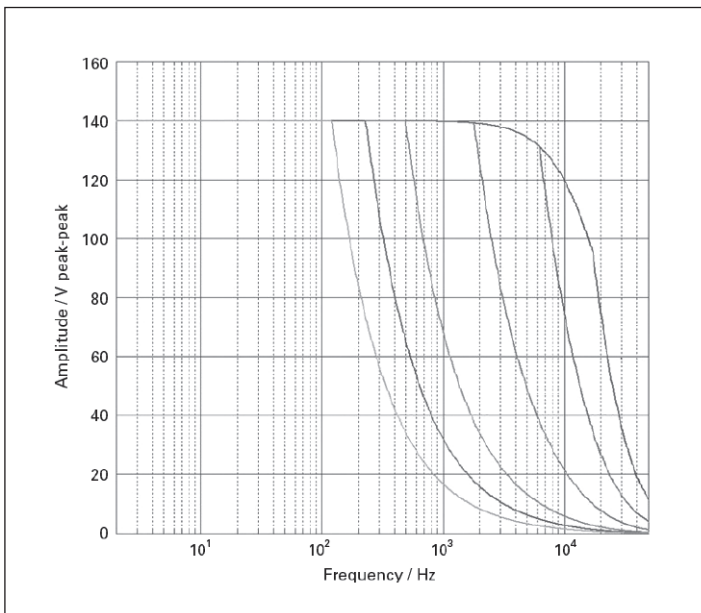

E-618: operating limits with various PZT loads (open-loop), capacitance is measured in μF

- Peak current 20 A
- Microsecond rise time
- 15 kHz bandwidth for high dynamics applications
- Ideal for fast switching or active vibration control with piezos
- Overheat protection for piezo actuators with temperature sensor
- Versions: 1 or 2 channels, OEM module, benchtop or 19" rackmount
- Optional computer interface and display modules

E-618.10	
Function	Power amplifier module for PICMA® multilayer piezo actuators
Amplifier	
Input voltage	-2 to 12 V
Output voltage*	-30 to 130 V
Peak output power	>3200 W (<0.3 ms)
Average output power	100 W (>0.3 ms)
Peak current	>20 A (<0.3 ms)
Average current	0.8 A (>0.3 ms)
Current limitation	Short-circuit-proof
Voltage gain	10 ±0.1
Ripple, noise, 0 to 10 kHz	20 mV _{pp} / 2.4 mV _{rms} (no load), <2 mV _{rms} (1µF)
Input impedance	100 kΩ
Interface and operation	
Piezo connector	LEMO EGG.1B.302.CLL, with security cover
Control input	BNC
Temperature sensor (piezo actuator)	PT 1000; LEMO socket; automatic deactivation of high voltage output at max. 150°C
Display	Power, temp overflow LEDs
DC offset	10-turn pot., adds 0 to 10 V to Control In
Miscellaneous	
Operating temperature range	5 to 50 °C (above 40 °C, power derated)
Dimensions	215 mm × 123 mm × 185 mm 42 HP / 3 RU 19" rackmount chassis
Mass	2.65 kg
Operating voltage	100 to 120 or 220 to 240 VAC, selectable
Max. power consumption	15 VA (no load) 160 VA (max. load)

*Max. 85 °C, deactivation of the piezo voltage output (internal overtemp protection)
Ask about custom designs!

E-470 / E-472 / E-421 PICA Piezo Controller

Modular High-Power Amplifier / Controller

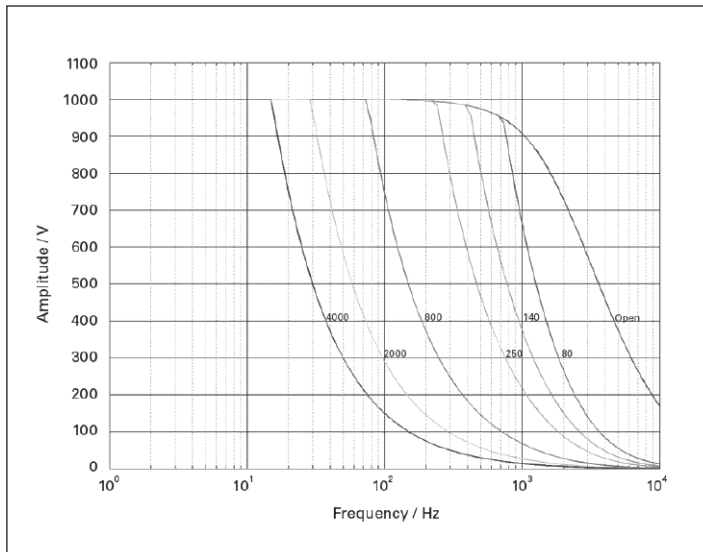

E-421, E-470, E-471, E-472: operating limits with various PZT loads, capacitance is measured in nF

- Peak power 550 W
- Output voltage range 3 to 1100 V or bipolar
- Position control (optional)
- Versions: 1 or 2 channels, OEM module, benchtop or 19" rackmount
- Optional computer interface and display modules

	E-470.20 / E-471.20 / E-472.20 / E-421.00	Unit
Function	Power amplifier for PICA high-voltage PZTs (servo-controller option for E-471)	
Amplifier		
Output voltage	Default: 3 to 1100 Selectable: -260 to +780 -550 to +550 +260 to -780 -3 to -1100	V
Amplifier channels	1 (E-472: 2)	
Average output power	110	W
Peak output power, <5 ms	550	W
Average current	100	mA
Peak current, <5 ms	500	mA
Amplifier bandwidth, small signal	DC to 3	kHz
Amplifier bandwidth, large signal	DC to 3	kHz
Ripple, noise, 0 to 100 kHz	<25 mV _{rms} 100 (200 nF)	mV _{rms} mV _{pp}
Current limitation	Short-circuit-proof	
Voltage gain	100 ±1 (default), -100 ±1	
Input impedance	100	kΩ
Control input voltage	Servo off: ±1/100 of selected output voltage range Servo on: 0 to 10 V	
Interface and operation		
PZT voltage output	LEMO EGG.0B.701.CJL1173	
Control input	BNC	
DC offset	10-turn pot., adds 0 to 10 V to Control In	
Miscellaneous		
Operating voltage	100 to 120 or 220 to 240 VAC, selectable (fuse change required)	
Operating temperature range	5 to 50 (above 40 °C, power derated)	°C
Mass	E-470: 5.2 E-471: 7.6 E-472: 10.1 E-421: 2.5	kg
Dimensions	236 mm × 132 mm × 296 mm + handles (E-470) 450 mm × 132 mm × 296 mm + handles (E-471, E-472) 215 mm × 123 mm × 185 mm (E-421)	

E-481 PICA Piezo High-Power Amplifier/Controller

2000 W and Energy Recovery for High Efficiency

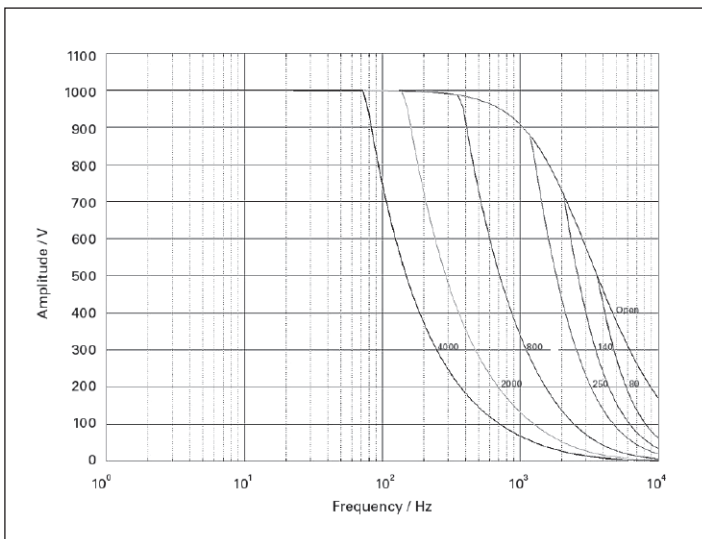

E-481: operating limits with various PZT loads, capacitance is measured in nF

- Peak power 2000 W
- Integrated energy recovery
- Output voltage 0 to ± 1100 V or bipolar
- Overheat protection for piezo actuators with temperature sensor
- Position control (optional)
- Optional computer interface and display modules

>> Energy recovery operating principle

Technology Glossary page 240

	E-481.00	Unit
Function	Power amplifier with energy recovery for PICA high-voltage PZTs	
Amplifier		
Output voltage	Default: 0 to 1100 Selectable: -260 to 780 -550 to 550 +260 to 780 0 to -1100	V
Amplifier channels	1	
Average output power	equivalent to 630 VA reactive power	
Peak output power <5 ms	2000	VA
Average current	>600	mA
Peak current, <5 ms	2000	mA
Amplifier bandwidth, small signal	5 kHz (660 nF), 1 kHz (3.4 μF)	
Amplifier bandwidth, large signal	1.4 kHz (660 nF), 350 Hz (3.4 μF)	
Ripple, noise, 0 to 100 kHz	150 2000 (100 nF)	mV _{rms} mV _{pp}
Current limitation	Short-circuit-proof	
Voltage gain	±100	
Input impedance	100	kΩ
Control input voltage	Servo off: ±1/100 of selected output voltage range Servo on: 0 to 10 V	
Interface and operation		
PZT voltage output socket	LEMO EGG.0B.701.CJL1173	
Control input socket	BNC	
DC offset	10-turn potentiometer, adds 0 to 10 V to Control In	
Temperature sensor	LEMO socket automatic deactivation of high voltage output at max. 85 °C	
Miscellaneous		
Operating voltage	100 to 120 / 220 to 240 VAC, 50 60 Hz (fuse change required)	
Operating temperature range	5 to 50 °C (above 40 °C, power derated)	
Mass	8.6	kg
Dimensions	288 mm × 450 mm × 158 mm + handles	

Requires piezo actuators with option P-177.50, temperature sensor and protective air connection for PICA HVPZT

E-482 PICA High-Power Piezo Driver / Servo Controller

High Energy Efficiency through Energy Recovery

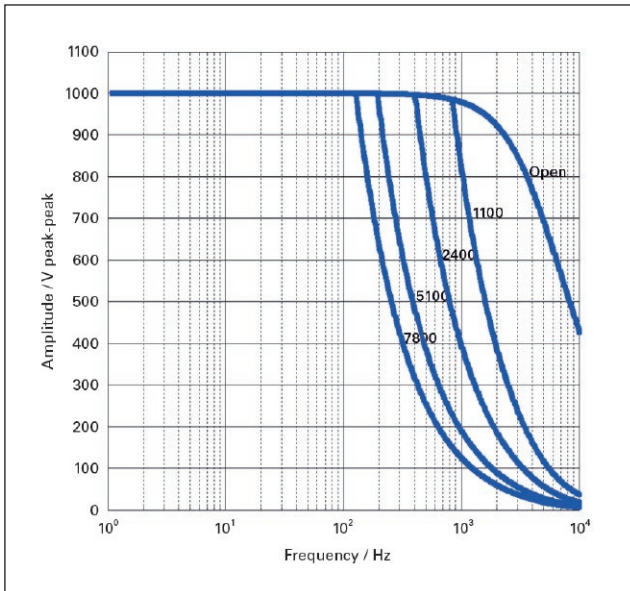

Operating limits with various PZT loads (open-loop), capacitance is measured in nF

- Peak current 6 A
- Output voltage to 1050 V
- Temperature sensor protects piezo actuator from overheating
- Position control (optional)
- Optional computer interface and display modules

>> Energy recovery operating principle

Technology Glossary page 240

	E-482.00	Unit
Function	Power amplifier with energy recovery for PICA high-voltage piezo actuators	
Amplifier		
Output voltage	Default: 0 to 1050 Selectable: -260 to +780, -525 to +525	V
Amplifier channels	1	
Average current (idle current)	2	A
Peak current, <5 ms	6	A
Current limitation	Short-circuit-proof	
Voltage gain	100	
Amplifier bandwidth, small signal	2 kHz (1 μ F)	
Amplifier bandwidth, large signal	400 Hz (5 μ F)	
Ripple, noise, 0 to 10 kHz, 1 μ F	300	mV _{rms}
Suggested capacitive load	1 μ F (min.), 17 μ F (max.)	
Input impedance	100	k Ω
Control input voltage	Servo off: $\pm 1/100$ of selected output range; servo on: 0 to 10 V	
Interface and operation		
Piezo connector	LEMO EGG.0B.701.CJL1173	
Analog input	BNC socket	
Temperature sensor (piezo actuator)	LEMO socket; deactivation of the piezo voltage output at 120 °C	
DC offset	10-turn potentiometer, adds 0 to ± 10 V to input voltage	
Miscellaneous		
Operating voltage	100 to 120 / 220 to 240 VAC, 50 to 60 Hz (fuse change required)	
Operating temperature range	5 to 40	°C

E-663 Three-Channel Piezo Driver

For Open-Loop Piezo Systems and Actuators without Position Sensors

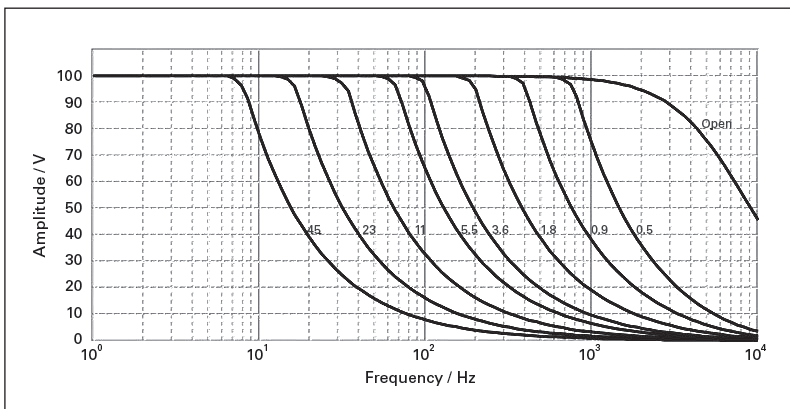

E-663: operating limits with various PZT loads (open-loop), capacitance is measured in μF

- 3 independent channels
- Peak power $3 \times 14 \text{ W}$
- 3 LED voltage displays
- Output voltage range -20 to 120 V

	E-663.00	Tolerance
Function	Power amplifier	
Channels	3	max.
Amplifier		
Input voltage	-2 to +12 V	
Output voltage	-20 to +120 V	min.
Peak output power per channel	14 W	max.
Average output power per channel	6 W	max.
Peak current per channel	140 mA	<5 ms
Average output current per channel	60 mA	>5 ms
Current limitation	Short-circuit-proof	
Noise, 0 to 100 kHz	<1 mV _{rms} <10mV _{pp}	
Voltage gain	10 ±0.1	
Input impedance	100 kΩ	
Interfaces and operation		
Piezo connector	3 × LEMO ERA.00.250.CTL	
Control input socket	3 × BNC	
Display	3 × 3 1/2 -digit, LED	
DC Offset	3 × 10-turn pot., adds 0 to 10 V to Control In	
Miscellaneous		
Operating temperature range	5 to 50 °C	
Dimensions	236 mm × 88 mm × 273 mm + handles	
Mass	4.6 kg	
Operating voltage	90 – 120 / 220 – 240 VAC, 50 – 60 Hz (linear power supply)	
Power consumption	60 W	max.

E-464 PICA Piezo Driver / Amplifier

For Piezo Systems and Actuators, for up to 3 Axes

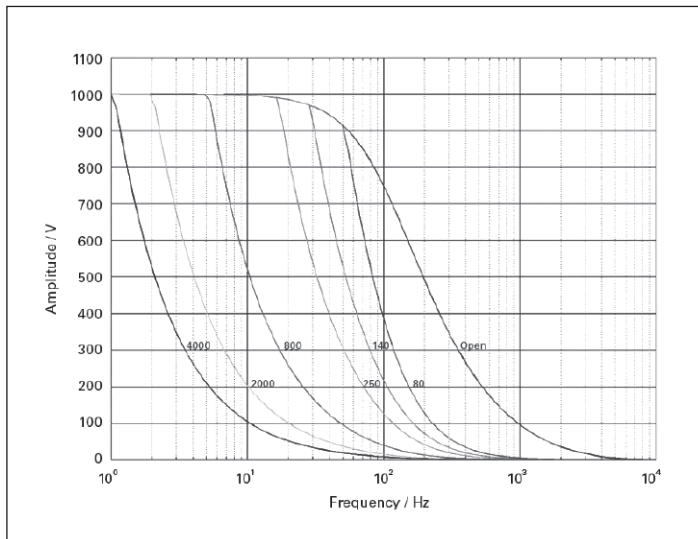

E-464: operating limits with various PZT loads, capacitance is measured in nanofarads

- 3 powerful channels
- Peak power $3 \times 25 \text{ W}$
- Output voltage range 0 to 1100 V
- 3 LED voltage displays

E-464.00	
Function	Power amplifier for PICA high-voltage PZTs
Amplifier	
Output voltage	0 to 1100 V
Amplifier channels	3
Average output power per channel	>3.5 W (max. 12 W if 1 channel is operated)
Peak output power per channel, <5 ms	25 W
Average current per channel	>3.5 mA (max. 12 W if 1 channel is operated)
Peak output current per channel, <5 ms	25 mA
Amplifier bandwidth, small signal	1 kHz
Amplifier bandwidth, large signal	3.5 Hz (660 nF); 35 Hz (70 nF)
Ripple, noise, 0 to 100 kHz	5 mV _{rms} 50 (100 nF) mV _{pp}
Current limitation	Short-circuit-proof
Voltage gain	100 ±1
Input impedance	100 kΩ
Control input voltage	0 to 11 V
Interface and operation	
PZT voltage output socket	3 × LEMO EGG.0B.701.CJL1173
Control input socket	3 × BNC
DC offset	3 × 10-turn potentiometer, adds 0 to 10 V to Control In
Display	3 × 3½-digit LED display
Miscellaneous	
Operating voltage	100 to 120 or 220 to 240 VAC, selectable (fuse change required)
Power consumption	65 VA
Operating temperature range	5 to 50 °C (above 40 °C, power derated)
Mass	4.3 kg
Dimensions	236 mm × 88 mm × 273 mm + handles

E-462 PICA Piezo Driver

Compact, Bench-Top or OEM Module



- Single-channel piezo driver
- Output voltage range 10 to 1000 V
- 12 V battery or external P/S operation
- For static or quasi-static operation
- Versions: Benchtop or OEM module

	E 462.00	E 462.OE1	Unit	Tolerance
Function	Power amplifier for PICA high-voltage PZTs	Power amplifier for PICA high-voltage PZTs		
Amplifier				
Channels	1	1		
Output voltage	10 to 1000	10 to 1000	V	
Average output power	0.3	0.3	W	
Peak output power <5 ms	0.5	0.5	W	
Average output current	0.3	0.3	mA	max.
Peak output current <5 ms	0.5	0.5	mA	
Current limitation	Short-circuit-proof	Short-circuit-proof		
Ripple, noise, 0 to 100 kHz	50 50 (100 nF)	50 50 (100 nF)	mV _{rms} mV _{pp}	
Voltage gain	100	200		±1
Input impedance	10	10	kΩ	
Frequency response	Static and quasi-static applications only	Static and quasi-static applications only		
Control input voltage	0 to 10	0 to 5	V	
Interface and operation				
PZT voltage output socket	LEMO EGG.0B.701.CJL1173	LEMO PHG.0B.701.CJL1173 D42		
Control input socket	BNC	Header pins		
DC offset	1-turn pot., adds 0 to 10 V to Control In	–		
Miscellaneous				
Dimensions	205 mm × 150 mm × 73 mm	67 mm × 38 mm × 20 mm		
Mass	0.5	0.25	kg	
Operating voltage	12 VDC, stabilized	12 VDC, stabilized	VDC	±10 %
Max. operating current	90	90	mA	
Operating temperature range	5 to 50 (above 40 °C, power derated)	5 to 50 (above 40 °C, power derated)	°C	
Power supply	Wall-plug unit	–		

Terms and Technology Glossary

A

Amplifier classification

PI uses the following amplifier classifications: Charge controlled, switched (class D), linear (class AB).

Amplifier resolution

Only for digitally controlled amplifiers: Measurement of the smallest digital output value (LSB) in mV.

Average current

Current that is available reliably over a longer period. Given as measured value. For multi-axis controllers, it is specified per channel.

B

Bandwidth

Max. operating frequency of a piezo driver, the measured value specifies the frequency in kHz, with which the amplitude is decreased by -3 dB. Large signal values refer to maximum output voltage. Small signal values refer to output voltage of 10 V_{pp}. The values are displayed in the amplifier operating diagram.

C

Capacitive base load (internal)

For switching amplifiers. Stabilizes the output voltage even without connected capacitive load (piezo actuator). The possible output power of a piezo controller / driver depends on internal and external capacitive loads.

Capacitive sensors

Capacitive sensors allow contactless measuring, do not introduce much energy into the piezo drive system and have a flat design. Their direct position measurement of the piezo actuators eliminates drift effects for travel ranges of up to 1.5 mm. The overall system, which consists of the stage, sensor technology, and electronics, gains on performance and precision. Due to noncontact measuring in the 10 µm up to approx. 2 mm range, it is possible to mount the capacitive sensor in the stage at the point where the motion actually takes place. The design consists of two conductive surfaces: A high-frequency alternating current generates a homogenous electric field between the two surfaces. Customers from the semiconductor industry also appreciate the small and versatile design as well as the lack of thermal build-up in the system. See "Sensor linearization".

Charge-controlled piezo driver

Driver that employs a charge control principle. Here, the input signal controls the amount of electrical charge that is transferred to the piezo actuator. The result is a highly repeatable, linear displacement of the piezo actuator in high-dynamics operation, without any additional position feedback. The typical hysteresis that piezo actuators show when operated with a voltage-controlled piezo amplifier can such be reduced to 2 % only.

It is recommended to monitor the piezo temperature to protect them from over temperature damage, especially in high-dynamic applications.

Class D piezo amplifier

See "Energy recovery operating principle".

Closed-loop operation

Piezo servo controllers have additional circuitry for position sensing and servo-control that compensates for nonlinearity, hysteresis, and creep. Displacement of the piezo is controlled by an analog signal. Positioning accuracy and repeatability down to the subnanometer range is possible, depending on the piezo mechanics and sensor type. High-resolution position sensors provide optimum positional stability and fast response in the nanometer range. The integrated notch filters (adjustable for each axis) improve stability and allow high bandwidth operation closer to the resonant frequency of the mechanics.

PI piezo drivers for PICMA[®] actuators have an output voltage range of up to -30 to +135 V to provide enough margin for the servo-controller to compensate e.g. for load changes. See "Open-loop operation", "Capacitive sensors", "Strain gauge sensors".

Control input voltage range

Also input voltage; for piezo controller / driver. Recommended range from -2 to 12 V. The usual gain value of 10 V leads to an output voltage of -20 to 120 V. Most PI controllers allow for an input voltage range of -3 to 13 V.

Controller

The controller is an electronic system component. It supplies the current and the voltage to the drive (amplifier) and also has internal computing capacities. The controller takes care of the control and evaluation of sensor signal, trajectory calculation, trajectory control, and the communication with a host.

Creep

An unwanted change in the displacement over time.

Crosstalk

Deviation from the ideal motion in axes perpendicular to the direction of motion.

Angular errors are xrx = roll, xry = pitch, xrz = yaw. Linear errors are lateral runout such as xty = straightness, xtz = flatness.

See "Linearity error".

Current consumption

Current consumption of the system on supply end. It is specified for controller without load. Alternatively, power consumption.

Current limitation

Short-circuit protection.

D**Direct metrology**

Position measuring is performed with the highest accuracy directly at the motion platform so that nonlinearity, mechanical play or elastic deformation have no influence on position measuring. Precision positioning systems use different encoder types as position sensor: Incremental encoders with different accuracy levels, absolute-measuring encoders that additionally make referencing unnecessary when a machine is switched on again, and for travel ranges under 2 mm, capacitive sensors.

Drift

See "Creep".

Drive type

Defines the types of drive supported by the controller / driver, such as DC motors, piezo stepping drives, piezo actuators.

Driver

The driver is an electronic system component. It supplies the current and the voltage to the driver (amplifier).

Dynamic digital linearization

Dynamic Digital Linearization (DDL) describes an iterative pre-shaping method minimizing the positioning error. DDL for example reduces the phase lag of the commanded and executed trajectory of repeated periodic motion patterns next to other piezoelectric motion effects. This is relevant for scanning applications, where a specific position must be identified and later be reapproached with high precision, or for applications where a trajectory must be followed very accurately for several processing steps.

E**Electrical capacitance**

The piezo capacitance values indicated in the technical data tables are small signal values (measured at 1 V, 1000 Hz, 20 °C, no load). Large-signal values at room temperature are by a factor of 1.3 to 1.6 higher. The capacitance of piezoelectrics changes with amplitude, temperature, and load, up to 200 % of the unloaded, small signal capacitance at room temperature. For detailed information on power requirements, refer to the amplifier frequency response graphs provided for piezo drivers and controllers.

Electronics

System component of a motion and positioning system. See "Controller", "Driver".

Encoder input

Maximum bandwidth (-3 dB) of the input signals for the encoder input.

Energy recovery operating principle

Switching amplifier (class D) with pulse width modulation (PWM) of the piezo output voltage. When the piezo actuator is discharged, a patented circuitry for energy recovery stores part of the returning energy in a capacitor and makes it reusable for the next charging cycle. The amplifier reduces the power consumption by up to 80 % compared to linear piezo amplifiers, runs cooler and provides better stability. Piezo drivers that use energy recovery are ideally suited for high-dynamics scanning and switching applications.

Extensive software package

To make systems more user friendly, software plays an important role in positioning systems. Customers expect a plug-and-play solution even if several positioning systems are combined or different drive systems need to interact, and that is why PI (Physik Instrumente) provides PIMikroMove® host software. You only need to enter your parameters into the application to avoid programming altogether. Also supports a number of text-based languages, has its own LabVIEW, Python and Matlab drivers, and the software is compatible with Windows, Linux, and OSX. However, not all software tools may be available for all controller versions.

Terms and Technology Glossary

F

Flatness

See “Crosstalk”.

Flexure guiding systems

Piezo systems from PI (Physik Instrumente) use lever-amplified piezo actuators as the drive, e.g., when adjusting optical lenses. For optimum results regarding dynamics and accuracy, it is necessary to ascertain and optimize the mechanical and piezo-electric properties such as the guiding accuracy, crosstalk or temperature-related drift in the overall system. Friction-free flexure guides that allow hysteresis-free motion steer the motion and retain the stiffness. Very small, but subnanometer precision motion is transferred to the required system motion by using lever amplification.

H

HVPZT

Acronym for High-Voltage PZT (actuator).

Hysteresis

Hysteresis in piezo actuators is based on crystalline polarization and molecular effects and occurs when reversing driving direction.

I

ID chip

An ID chip is located in the connector of many piezo stages. When the stage is calibrated at the factory with a digital controller, the calibration data is saved together with specific product information on the ID chip. When switched on, digital electronics read the data from the ID chip of the connected stage. Stages, whose ID chip contains the calibration data, can therefore be connected to any suitable digital electronics without renewed calibration.

Incremental encoder

PI uses noncontact optical encoders to measure the actual position directly at the motion platform with the greatest accuracy so that nonlinearity, mechanical play or elastic deformation have no influence on position measuring. See “Direct metrology”.

Input level

Permissible input level for digital interfaces.

Integrated feedback sensor

Absolute measuring capacitive, piezo resistive (PRS) or strain gauge (SGS) and optical (absolute and relative) sensors are used to provide position information to the controller.

L

Lateral force, max.

Maximum lateral force perpendicular to the operating direction. For piezo systems the lateral force is limited by the piezo actuator and the flexure designs. For XY stages the push / pull force capacity of the other module (in its operating direction) limits the lateral force that can be tolerated.

Limit switches

Function: Optical, magnetic.

Linear amplifier / driver

Most piezo drivers use linear amplifiers (class AB) to generate the output voltage. In open-loop (voltage-controlled) piezo operation the amplifier output voltage is determined by an analog input optionally combined with a DC offset.

Linearity error

Deviation in motion direction, of measured position from commanded position (positioning accuracy). Measured with an external, traceable device. The value is given as a percentage of the entire measuring range.

Measurement of the linearity error: The target and measured actual values of the positions are plotted against each other, a line is drawn through the first and last data point, and the maximum absolute deviation is determined. A linearity error of 0.1 % corresponds to an area of ± 0.1 % around the ideal line. Example: A linearity error of 0.1 % over a measuring range of 100 μm produces a possible maximum error of 0.1 μm .

Linearization

Digital piezo controllers offer the best positioning accuracy through linearization algorithms with higher-order polynomials. The linearity error with capacitive sensors can be reduced to less than 0.01 %. See “Dynamic digital linearization”, “Sensor linearization”.

Load capacity

Maximum vertical load, when the stage is mounted horizontally. Limited by the flexure designs or the load capacity of the piezo actuators.

M

Measurement range extension factor

For capacitive sensors, used by PI.

N

NEXACT® Piezo walking drive

Precision piezomotor that creates the walking motion by means of piezo bending elements, in order to move a runner. The drives are very compact and achieve relatively high velocities around 10 mm/s, and forces up to 10 N. A suitable selection of the piezo elements optimizes step size, clamping force, velocity, and stiffness for the respective applications.

NEXLINE® Piezo walking drive

High-load piezomotor that combines piezo clamping and shear actuators, in order to move a runner. The drives feature particularly high force and stiffness of several 100 N. They are capable of dynamically compensating oscillations in the range of a few micrometers with nanometer resolution. Furthermore the drives are designed for positioning and holding forces of up to 800 N, and work at velocities of about 1 mm/s.

Noise

For capacitive sensors. In extended measurement ranges, noise is considerably higher than in the nominal measurement range.

Nonlinearity

See "Linearity error".

O

Open-loop operation

The actuator is used without a position sensor. Displacement roughly corresponds to the drive voltage. Creep, nonlinearity and hysteresis remain uncompensated. Open-loop operation is ideal for applications where fast response and very high resolution with maximum bandwidth are essential. Here, commanding and reading the target position in absolute values is either not important or carried out by external position sensors.

Operating limits

Values measured at an ambient temperature of 20° C. A sine is used as control signal in open-loop operation. The amplifier works linearly within the operating limits, in particular without thermal limitation.

Operating temperature range

In any case, the device can be operated safely in the maximum permissible temperature range. To avoid internal overheating however, full load is no longer available above a certain temperature (maximum operating temperature under full load). Nevertheless, recalibration or zero-point-adjustment may be required if the system is operated at different temperatures. Performance specifications are valid for room temperature range. Please refer to individual datasheets and contact PI for more details.

Operating voltage

Allowed control input voltage range (also input frequency) for the supply of the device.

Output voltage

The output voltage of piezo controllers show exceptional long-term stability with variations of only a few millivolt.

Overtemperature protection

Switch-off temperature for voltage output. No automatic restart.

P

Patents

PI owns a large variety of patents on piezo and motor technology.

Parallel-kinematic piezo stages

Optimal trajectory fidelity is achieved using a parallel-kinematics, parallel-metrology piezo stage with capacitive sensors. In a parallel-kinematics, multi-axis system, all actuators act directly on one moving platform. This means that all axes move the same minimized mass and can be designed with identical dynamic properties. Parallel-kinematic systems have additional advantages over serially stacked systems, including more compact construction and no cumulative errors from the individual axes. Multi-axis nanopositioning systems equipped with direct metrology are able to measure platform position in all degrees of freedom against one common reference. In such systems, undesirable motion from one actuator in the direction of another (crosstalk) is detected immediately and actively compensated by the servo loops. This active trajectory control concept can keep deviation from a trajectory to under a few nanometers, even in dynamic operation.

Parallel metrology

Each sensor measures the position of the same moving platform in the respective degree of freedom. This keeps the off-axis runout, or crosstalk, of all actuators inside the servo-control loop and allows it to be corrected automatically.

Terms and Technology Glossary

Peak current

Only available for very short times, typically under a few milliseconds. It is used to estimate the possible dynamics with a certain capacitive load. Note: In this case, the piezo controller / driver does not necessarily work linearly.

PICA / PICA Power

PICA piezo actuators are specifically designed for high duty cycle applications. PICA Power actuators are additionally optimized for high-temperature working conditions.

All materials used are specifically matched for robustness and lifetime. Endurance tests on PICA actuators prove consistent performance, even after billions (1,000,000,000) of cycles. The combination of high displacement and low electrical capacitance provides for excellent dynamic behavior with reduced driving power requirements.

PICMA® Multilayer piezo actuators

PICMA® actuators take advantage of the indirect piezoelectric effect and achieve high forces with relatively low voltages. They only need a small amount of installation space. At the same time, the PICMA® actuators are very dynamic and can reach a position with a hitherto unattained precision. This is the reason why they are used as micropumps in metering technology. Due to their ceramic insulation, PICMA® actuators exhibit high reliability and climate resistance. PI (Physik Instrumente) also equips PICMA® actuators with individual connections for customer applications.

PICMAWalk

PICMAWalk drives achieve feed forces up to 50 N and holding forces to 60 N. The maximum velocity is 15 mm/s. PICMAWalk uses the proven PICMA® multilayer piezo actuators. That means lower piezo voltages to 120 V. PICMA® piezo actuators also ensure a long lifetime and the outstanding reliability of the PICMAWalk technology.

PiezoMove®

PiezoMove® actuators combine guided motion with long travel ranges of up to 1 mm as well as an optional sensor which provides precision up to 10 nanometers. The high-precision, frictionless flexure guides achieve very high stiffness as well as extremely low lateral displacement.

This makes them easier to handle than a simple piezo actuator, but still keeps them extremely compact. The number and size of the piezo actuators used determine stiffness and force generation. Due to these features, their small dimensions and the inexpensive design, the PiezoMove® lever actuators are particularly suitable for OEM applications.

Piezoresistive sensors (PRS)

Strain gauge sensors that consist of a semiconductor foil. See "Strain gauge sensors".

PiezoWalk® walking drive

PiezoWalk® drives take advantage of the piezo walking principle and combine a subnanometer resolution with high forces, a robust design, and a scalable travel range. Industry customers use walking drives for travel ranges greater than 1 mm and to hold a stable position with nanometer precision resolution. PI (Physik Instrumente) offers walking drives with high feed forces as well as positioning and holding forces, but also relatively high velocities, and they also have a long lifetime in a vacuum. See "NEXLINE®", "NEXACT®", and "PICMAWalk".

PIRest

Piezo actuator technology for active adjustment of consistently stable gaps of several μm with subnanometer precision. The PIRest actuator is only powered during the actual positioning sequence and holds its position without power.

Pitch

See "Crosstalk".

Power consumption

Maximum power consumption under full load.

Preloaded piezo actuator

Piezoelectric stacks protected by an internal preload. The preload ensures a safe operation in any kind of application scenario and is ideal for dynamic applications and for tensile loads as well. Preloaded piezo actuators are intended for integration into a customer's system and have no guides. If off-axis motion cannot be tolerated, an external guide is required.

Profile generator

Functionality of motor controllers that allows motion profiles such as linear interpolation, point-to-point, trapezoid, double bends. For several axes: Electronic gearing.

Push / pull force capacity (in operating direction)

Specifies the maximum forces that can be applied to the system along the active axis. Limited by the piezoelectric material and the flexure design. If larger forces are applied, damage to the piezo actuator, the flexures or the sensor can occur. The force limit must also be considered in dynamic applications.

Example: the dynamic forces generated by sinusoidal operation at 500 Hz, 20 μm peak-to-peak, 1 kg moved mass, are approximately ± 100 N.

PZT

Acronym for plumbum (lead) zirconate titanate. Polycrystalline ceramic material with advanced piezoelectric properties. Often also used to refer to a piezo actuator or translator.

R

Reference point switch

Function: Optical, magnetic.

Repeatability

Typical values in closed-loop operation mode (RMS, 1 σ). Repeatability is a percentage of the total distance or angle traveled. For small ranges, repeatability may be significantly better.

Resolution

Position resolution relates to the smallest change in displacement that can still be detected by the measuring devices. The resolution in piezo-based positioning systems and piezo actuators is basically unlimited because it is not affected by static or sliding friction. Instead, the equivalent to electronic noise is specified. Values are typical results (RMS, 1 σ).

Resonant frequency

No load: First resonant frequency in operating direction.
With load: Resonant frequency of the loaded system.
Resonant frequency does not specify the maximum operating frequency. PI recommends an operating frequency in open-loop of max. one third of the resonant frequency. Customized systems may differ from that. Please contact PI for more details.

Rise time

Time constant of the controller / driver. Time required for increasing the voltage range from 10 % to 90 %.

Ripple, noise, 0 to 100 kHz

Ripple of voltage in mVpp with unique frequency. Noise over the entire frequency range.

Roll

See "Crosstalk".

Rotational runout

See "Crosstalk".

S

Sensor bandwidth

Measured value that specifies the frequency, with which the amplitude decreased by -3 dB.

Sensor linearization

For capacitive sensors, the signal conditioning electronics demonstrates a notably low noise level. The integrated linearization system (ILS) compensates for the influences of parallelism errors between the capacitor plates.

Sensor resolution

The sensor can be the critical element in position resolution, for this reason the sensor resolution can be specified separately if necessary.

Serial kinematics

Each actuator acts on its own platform. There is a clear relationship between actuators and motion axes. The advantages are the relatively simple assembly and multi-axis control. The dynamic characteristics depend on the individual axis. Guiding errors cumulate and the overall guiding accuracy is poorer if compared to "Parallel kinematics", see there.

Serial metrology

One sensor is assigned to each moving axis to be servo-controlled. Undesired off-axis motion, guiding error or crosstalk, go unnoticed and uncorrected. See "Parallel metrology".

Specifications

Performance specifications are valid for room temperature (22 \pm 3 $^{\circ}$ C) and closed-loop systems are calibrated at this temperature (specifications for different operating temperatures on request). Recalibration is recommended for operation at significantly higher or lower temperature. Custom designs for ultralow or ultrahigh temperatures on request.

Stiffness

Spring constant, nonlinear for piezoelectric materials. Static large signal stiffness of the stage in operating direction at room temperature. Small signal stiffness and dynamic stiffness may differ because of effects caused by the active nature of piezoelectric material or compound effects, for example.

Straightness

See "Crosstalk".

Terms and Technology Glossary

Strain gauge sensor (SGS)

Strain gauge sensors consist of a thin metal wire packaged on a foil (SGS), or a semiconductor foil (PRS), which is attached to the piezo actuator or to the guiding system of a flexure stage. This type of position measurement is done with contact and indirectly, since the position of the moving platform is derived from a measurement on the lever, guide or piezo stack. Strain gauge sensors derive the position information from their expansion and thus change of resistivity. Full-bridge circuits with several strain gauge sensors per axis improve thermal stability and are used for signal shaping.

Suggested capacitive load

For switching amplifiers. The possible output power of a piezo controller / driver depends on internal and external capacitive loads.

Switching amplifier / driver

See "Energy recovery operating principle".

T

Tilting mirrors

Tilting mirrors, or other fast steering mirrors or tip / tilt platforms are used for example, for active optics applications and beam deflection in laser processing and laser steering. These piezo stages provide two orthogonal tip / tilt axes with a common center of rotation. Their parallel-kinematic design creates identical performance in the tip and tilt axis, with a common fixed pivot point and no change of polarization direction. The bandwidth, resonant frequencies, and acceleration are often higher than with voice coil or galvo scanners. Tilting mirrors are wear free due to the flexure guidings used in the design.

Trajectory control

Provisions to prevent deviation from the specified trajectory. Can be passive (e.g., flexure guidance) or active (e.g., using additional active axes and sensors).

Translator

A linear actuator.

U

User software and functions

PIMikroMove®, PI General Command Set (GCS). Drivers for LabVIEW, shared libraries for Windows and Linux. Compatible with µManager, MetaMorph, MATLAB. Wave Generator. Linearization. Data recorder. Auto zero. Trigger I/O. Software configurable servo parameters. See "Extensive software package".

V

Vacuum-compatible versions

In a large number of industry sectors, production in a vacuum is becoming increasingly more important. Therefore, PI (Physik Instrumente) offers various different drive technologies to its customers that can be operated in a vacuum of 10^{-7} or even 10–10 hPa. This includes piezo actuators that work in strong magnetic fields and in a cryogenic environment, piezo systems with travel ranges lower than 1.5 mm and subnanometer precision, piezomotors in a variety of designs with respect to force, dynamics, and travel range, as well as classical motorization with specially designed DC or stepper motors that allow greater travel ranges.

Y

Yaw

See "Crosstalk".

Physik Instrumente (PI) GmbH & Co. KG
 Auf der Roemerstrasse 1 76228 Karlsruhe
 Germany
 Phone +49 721 4846-0
 Fax +49 721 4846-1019
 info@pi.ws
 www.pi.ws

General Management: Dr. Karl Spanner, Dr. Peter Schittenhelm, Markus Spanner;
 Commercial Register: Reg.-Gericht Mannheim: HRA 104804; VAT-No.: DE 1431 828 03;
 WEEE-Reg.-No.: DE 93978928;
 General Partner: Physik Instrumente (PI) Verwaltungs GmbH;
 Commercial Register: Reg.-Gericht Mannheim: HRB 109941;

Although the information in this document has been compiled with the greatest care, errors cannot be ruled out completely. Therefore, we cannot guarantee the information being complete, correct and up to date. Illustrations may differ from the original and are not binding. PI reserves the right to supplement or change the information provided without prior notice.

The following company names and brands are registered trademarks of Physik Instrumente (PI) GmbH & Co. KG: PI®, PIC®, NanoCube®, PICMA®, PLine®, NEXLINE®, PiezoWalk®, NEXACT®, Picoactuator®, Plnano®, PIMag®

The following company names or brands are the registered trademarks of their owners:
 µManager, LabVIEW, Leica, Linux, MATLAB, MetaMorph, Microsoft, National Instruments, Nikon, Olympus, Windows, Zeiss
 CAT131E Piezosystems 12/2017 5.0 © Physik Instrumente (PI) GmbH & Co. KG 2017. Subject to change without notice.
 All contents, including texts, graphics, data etc., as well as their layout, are subject to copyright and other protective laws.
 Any copying, modification or redistribution in whole or in parts is subject to a written permission of PI.



Headquarters

GERMANY

**Physik Instrumente (PI)
GmbH & Co. KG**
Auf der Roemerstrasse 1
76228 Karlsruhe
Phone +49 721 4846-0
Fax +49 721 4846-1019
info@pi.ws
www.pi.ws

PI miCos GmbH
Freiburger Strasse 30
79427 Eschbach
Phone +49 7634 5057-0
Fax +49 7634 5057-99
info@pimicos.com
www.pi.ws

PI Ceramic GmbH
Lindenstrasse
07589 Lederhose
Phone +49 36604 882-0
Fax +49 36604 882-4109
info@piceramic.com
www.piceramic.com



© Physik Instrumente (PI) GmbH & Co. KG

All contents, including texts, graphics, data etc., as well as their layout, are subject to copyright and other protective laws. Any copying, modification or redistribution in whole or in parts is subject to a written permission of PI.

Although the information in this document has been compiled with the greatest care, errors cannot be ruled out completely. Therefore, we cannot guarantee for the information being complete, correct and up to date. Illustrations may differ from the original and are not binding. PI reserves the right to supplement or change the information provided without prior notice.

Subsidiaries

USA (East) & CANADA

PI (Physik Instrumente) L.P.
Auburn, MA 01501
www.pi-usa.us

USA (San Francisco Bay Area)

PI (Physik Instrumente) L.P.
Sausalito, CA 94965
www.pi-usa.us

ITALY

Physik Instrumente (PI) S. r. l.
Bresso
www.pionline.it

FRANCE

PI France SAS
Aix-en-Provence
www.pi.ws

JAPAN

PI Japan Co., Ltd.
Tokyo
www.pi-japan.jp

CHINA

**Physik Instrumente
(PI Shanghai) Co., Ltd.**
Shanghai
www.pi-china.cn

SOUTHEAST ASIA

**PI (Physik Instrumente)
Singapore LLP**
Singapore
www.pi-singapore.sg
For ID / MY / PH / SG / TH / VNM

KOREA

PI Korea Ltd.
Seoul
www.pikorea.co.kr

USA (West) & MEXICO

PI (Physik Instrumente) L.P.
Irvine, CA 92620
www.pi-usa.us

UK & IRELAND

PI (Physik Instrumente) Ltd.
Cranfield, Bedford
www.physikinstrumente.co.uk

NETHERLANDS

PI Benelux B.V.
Sint-Oedenrode
www.pi.ws/benelux

SPAIN

Micos Iberia S.L.
Vilanova i la Geltrú
www.pimicos.es

PI Japan Co., Ltd.
Osaka
www.pi-japan.jp

**Physik Instrumente
(PI Shanghai) Co., Ltd.**
Beijing
www.pi-china.cn

TAIWAN

**Physik Instrumente (PI)
Taiwan Ltd.**
Taipei
www.pi-taiwan.com.tw