

MP136E
U-651 Rotation Stage
User Manual

Version: 1.1.0

Date: 25.10.2016

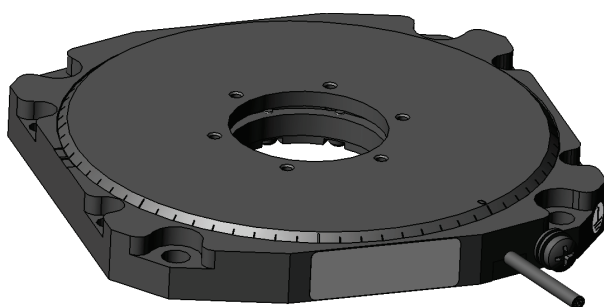

This document describes the following products:

- **U-651.03**
 PLine® rotation stage, 0.3 Nm torque,
 incremental encoder, 9 µrad resolution, Sub-D
 connector
- **U-651.03V**
 PLine® rotation stage, 0.3 Nm torque,
 incremental encoder, 9 µrad resolution, Sub-D
 connector, vacuum-compatible to 10⁻⁶ hPa
- **U-651.04**
 PLine® rotation stage, 0.3 Nm torque,
 incremental encoder, 4 µrad resolution, Sub-D
 connector
- **U-651.04V**
 PLine® rotation stage, 0.3 Nm torque,
 incremental encoder, 4 µrad resolution, Sub-D
 connector, vacuum-compatible to 10⁻⁶ hPa



The following company names and brands are registered trademarks of Physik Instrumente (PI) GmbH & Co. KG:

PI®, NanoCube®, PICMA®, PILine®, NEXLINE®, PiezoWalk®, NEXACT®, Picoactuator®, Plnano®, PIMag®, Q-Motion®

PI owns the following patents or patent applications in the field of ultrasonic piezo motor technology (PILine®):

Germany: DE102004024656A1, DE102004044184B4, DE102004059429B4, DE102005010073A1, DE102005039357B4, DE102005039358A1, DE102006041017B4, DE102008012992A1, DE102008023478A1, DE102008058484A1, DE102010022812A1, DE102010047280A1, DE102010055848, DE102011075985A1, DE102011082200A1, DE102011087542B3, DE102011087542B3, DE102011087801B4, DE102011108175, DE102012201863B3, DE19522072C1, DE19938954A1

Europe: EP0789937B1EP1210759B1, EP1267425B1, EP1581992B1, EP1656705B1, EP1747594B1, EP1812975B1, EP1861740B1, EP1915787B2, EP1938397B1, EP2095441B1, EP2130236B1, EP2153476B1, EP2164120B1, EP2258004B1, EP2608286A2

USA: US2010/0013353A1, US5872418A, US6765335B2, US6806620B1, US6806620B1, US7218031B2, US7598656B2, US7737605B2, US7795782B2, US7834518B2, US7973451B2, US8253304B2, US8344592B2, US8482185B2

Japan: JP2011514131, JP2011522506, JP3804973B2, JP4377956, JP4435695, JP4477069, JP4598128, JP4617359, JP4620115, JP4648391, JP4860862, JP4914895, JP2013539346

China: ZL200380108542.0, ZL200580015994.3, ZL200580029560.9, ZL200580036995.6, ZL200680007223.4, ZL200680030007.1, ZL200680042853.5

International patent applications: WO2009059939A2, WO2010121594A1, WO2012048691A2, WO2012113394A1, WO2012155903A1, WO2013034146A3, WO2013117189A2

© 2016 Physik Instrumente (PI) GmbH & Co. KG, Karlsruhe, Germany. The text, photographs and drawings in this manual are protected by copyright. With regard thereto, Physik Instrumente (PI) GmbH & Co. KG retains all the rights. The use of any text, images, and drawings is permitted only in part and only when indicating the source.

Original instructions

First printing: 25.10.2016

Document number: MP136E, CBo, Version 1.1.0

Subject to change without notice. This manual is superseded by any new release. The latest release is available for download (p. 3) on our website.

Contents

1	About this Document	1
1.1	Objective and Target Audience of this User Manual.....	1
1.2	Symbols and Typographic Conventions.....	1
1.3	Definition	2
1.4	Figures	2
1.5	Other Applicable Documents	3
1.6	Downloading Manuals.....	3
2	Safety	5
2.1	Intended Use	5
2.2	General Safety Instructions	5
2.3	Organizational Measures.....	6
3	Product Description	7
3.1	Model Overview	7
3.2	Product View	8
3.3	Product Labeling.....	8
3.4	Scope of Delivery.....	10
3.5	Suitable Controllers	10
3.6	Accessories	10
3.7	Technical Features.....	11
3.7.1	Rotary Encoder	11
3.7.2	Reference Point Switch.....	11
3.7.3	ID Chip.....	11
4	Unpacking	13
5	Installation	15
5.1	General Notes on Installation.....	15
5.2	Connecting the U-651 to the Protective Earth Conductor	17
5.3	Mounting the U-651 onto a Surface.....	18
5.4	Affixing the Load to the U-651	20
5.5	Connecting the Vacuum Version to the Controller	22
6	Start-Up and Operation	23
6.1	General Notes on Start-Up and Operation.....	23
6.2	Starting up the U-651	26

7	Maintenance	29
7.1	General Notes on Maintenance	29
7.2	Performing a Maintenance Run	29
7.3	Cleaning the U-651	30
8	Troubleshooting	31
9	Customer Service	33
10	Technical Data	35
10.1	Specifications.....	35
10.1.1	Data Table.....	35
10.1.2	Reference Point Switch Specifications	36
10.1.3	Maximum Ratings.....	36
10.1.4	Specifications for Vacuum-Compatible Versions	36
10.2	Ambient Conditions and Classifications	37
10.3	Motor Power	38
10.3.1	Motor Power and Operating Voltage.....	38
10.3.2	Velocity and Torque.....	39
10.3.3	Motor Power and Lifetime	40
10.3.4	Influence of Downtimes on the Torque.....	41
10.4	Dimensions	42
10.5	Pin Assignment	43
11	Old Equipment Disposal	45
12	EC Declaration of Conformity	47

1 About this Document

In this Chapter

Objective and Target Audience of this User Manual	1
Symbols and Typographic Conventions	1
Definition	2
Figures.....	2
Other Applicable Documents.....	3
Downloading Manuals	3

1.1 Objective and Target Audience of this User Manual

This manual contains information necessary for the intended use of the U-651.

It assumes that the reader has a fundamental understanding of basic servo systems as well as motion control concepts and applicable safety procedures.

The latest versions of the user manuals are available for download (p. 3) on our website.

1.2 Symbols and Typographic Conventions

The following symbols and typographic conventions are used in this user manual:

CAUTION



Dangerous situation

If not avoided, the dangerous situation will result in minor injury.

- Actions to take to avoid the situation.

NOTICE





Dangerous situation

If not avoided, the dangerous situation will result in damage to the equipment.

- Actions to take to avoid the situation.

INFORMATION

Information for easier handling, tricks, tips, etc.

Symbol/Label	Meaning
1. 2.	Action consisting of several steps whose sequential order must be observed
➤	Action consisting of one or several steps whose sequential order is irrelevant
▪	List item
p. 5	Cross-reference to page 5
RS-232	Labeling of an operating element on the product (example: socket of the RS-232 interface)
 	Warning signs affixed to the product that refer to detailed information in this manual.

1.3 Definition

Term	Explanation
Load capacity	Maximum load capacity in the vertical direction when the rotation stage is mounted horizontally. The contact point of the load is in the center of the platform.
Rotary encoder	The rotary encoder is an incremental sensor for capturing changes in position. Signals from the sensor are used for axis position feedback. After switching on the controller a reference point definition must be performed before absolute target positions can be commanded and reached.

1.4 Figures

For better understandability, the colors, proportions, and degree of detail in illustrations can deviate from the actual circumstances. Photographic illustrations may also differ and must not be seen as guaranteed properties.

1.5 Other Applicable Documents

The devices and software tools that are mentioned in this documentation are described in their own manuals.

Description	Document
C-867.1U PLine® controller	MS223E user manual
C-877.2U12 PLine® controller	MS233E user manual
PIMikroMove	SM148E software manual
PLine® stages	MP121EK short instructions

1.6 Downloading Manuals

INFORMATION

If a manual is missing or problems occur with downloading:

- Contact our customer service department (p. 33).

INFORMATION

For products that are supplied with software (CD in the scope of delivery), access to the manuals is protected by a password. Protected manuals are only displayed on the website after entering the password.

The password is included on the CD of the product.

For products with CD: Identify the password

1. Insert the product CD into the PC drive.
2. Switch to the Manuals directory on the CD.
3. In the Manuals directory, open the Release News (file including *releasenews* in the file name).
4. Find the user name and the password in the section "User login for software download" in the Release News.

Downloading manuals

1. Open the website **www.pi.ws**.
2. If access to the manuals is protected by a password:
 - a) Click **Login**.
 - b) Log in with the user name and password.
3. Click **Search**.
4. Enter the product number up to the period (e.g., P-882) or the product family (e.g., PICMA® Bender) into the search field.
5. Click **Start search** or press the key.
6. Open the corresponding product detail page in the list of search results:
 - a) If necessary: Scroll down the list.
 - b) If necessary: Click **Load more results** at the end of the list.
 - c) Click the corresponding product in the list.
7. Scroll down to the **Downloads** section on the product detail page.
The manuals are displayed under **Documentation**.
8. Click the desired manual and save it to the hard disk of your PC or to a data storage medium.

2 Safety

In this Chapter

Intended Use.....	5
General Safety Instructions.....	5
Organizational Measures.....	6

2.1 Intended Use

The U-651 is a laboratory device as defined by DIN EN 61010-1. It is intended for indoor use and use in an environment that is free of dirt, oil and lubricants.

In accordance with its design and realization, the U-651 is intended for single-axis positioning, adjusting and rotation of loads in at different velocities in interval operation. The U-651 is **not** intended for applications in areas in which a failure would present severe risks to human beings or the environment.

The intended use of the U-651 is only possible when completely mounted and connected.

The U-651 uses PILine® ultrasonic piezomotors as a drive and must be operated with a suitable controller (p. 10). The controller is not included in the scope of delivery of the U-651.

2.2 General Safety Instructions

The U-651 is built according to state-of-the-art technology and recognized safety standards. Improper use can result in personal injury and/or damage to the U-651.

- Only use the U-651 for its intended purpose, and only use it if it is in a good working order.
- Read the user manual.
- Immediately eliminate any faults and malfunctions that are likely to affect safety.

The operator is responsible for the correct installation and operation of the U-651.

Piezomotors are driven by piezo actuators. After disconnection from the electronics, piezo actuators can remain electrically charged for several hours. Temperature changes can also induce charges in piezo actuators. Touching charged parts of the U-651 can cause slight injuries from electric shock.

- Do **not** open the U-651.
- Do **not** touch the contacts in the connector of the U-651.

If a protective earth conductor is not or not properly connected, dangerous touch voltages can occur on the U-651 in the case of malfunction or failure of the system. If touch voltages exist, touching the U-651 can result in minor injuries from electric shock.

- Connect the U-651 to a protective earth conductor (p. 17) before start-up.
- Do **not** remove the protective earth conductor during operation.
- If the protective earth conductor has to be removed temporarily (e.g., in the case of modifications), reconnect the U-651 to the protective earth conductor before starting it up again.

Mechanical forces can damage or misalign the U-651.

- Avoid impacts that affect the U-651.
- Do **not** drop the U-651.
- Do **not** exceed the maximum permissible stress and load capacities (p. 35).

2.3 Organizational Measures

User manual

- Always keep this user manual available with the U-651. The latest versions of the user manuals are available for download (p. 3) on our website.
- Add all information from the manufacturer to the user manual, for example supplements or technical notes.
- If you give the U-651 to other users, also include this user manual as well as other relevant information provided by the manufacturer.
- Only use the device on the basis of the complete user manual. Missing information due to an incomplete user manual can result in minor injury and damage to equipment.
- Only install and operate the U-651 after you have read and understood this user manual.

Personnel qualification

The U-651 may only be installed, started up, operated, maintained, and cleaned by authorized and appropriately qualified personnel.

3 Product Description

In this Chapter

Model Overview.....	7
Product View.....	8
Product Labeling.....	8
Scope of Delivery.....	10
Suitable Controllers.....	10
Accessories.....	10
Technical Features.....	11

3.1 Model Overview

The U-651 is available in the following versions:

Model	Description
U-651.03	Rotation stage with low profile and PLine® ultrasonic piezomotors, >360° rotation range, velocity 540 °/s. Direct position measurement with incremental encoder, 9 µrad resolution, Sub-D connector
U-651.03V	Rotation stage with low profile and PLine® ultrasonic piezomotors, >360° rotation range, velocity 540 °/s. Direct position measurement with incremental encoder, 9 µrad resolution, Sub-D connector, vacuum-compatible to 10 ⁻⁶ hPa
U-651.04	Rotation stage with low profile and PLine® ultrasonic piezomotors, >360° rotation range, velocity 540 °/s. Direct position measurement with incremental encoder, 4 µrad resolution, Sub-D connector
U-651.04V	Rotation stage with low profile and PLine® ultrasonic piezomotors, >360° rotation range, velocity 540 °/s. Direct position measurement with incremental encoder, 4 µrad resolution, Sub-D connector, vacuum-compatible to 10 ⁻⁶ hPa

3.2 Product View

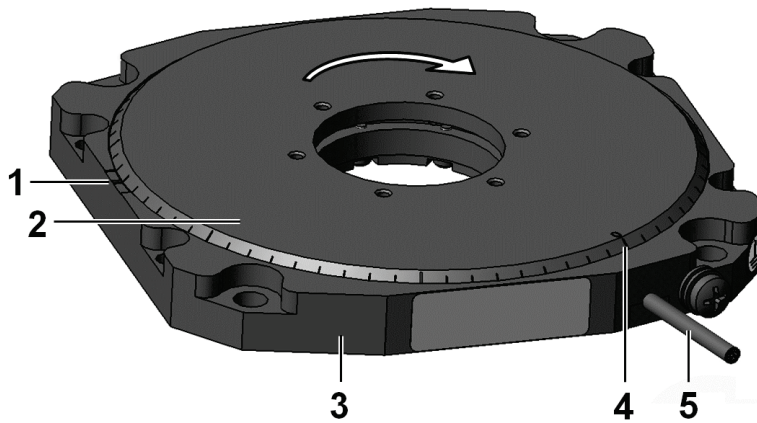

Figure 1: U-651 product view

- 1 0° mark* in the base body
- 2 Moving platform
- 3 Base body
- 4 0° mark* of the moving platform
- 5 Cable exit

The arrow in the figure shows the positive direction of motion.

*0° mark: After a reference move of the U-651, the 0° mark of the moving platform is at the 0° mark in the base body.

3.3 Product Labeling

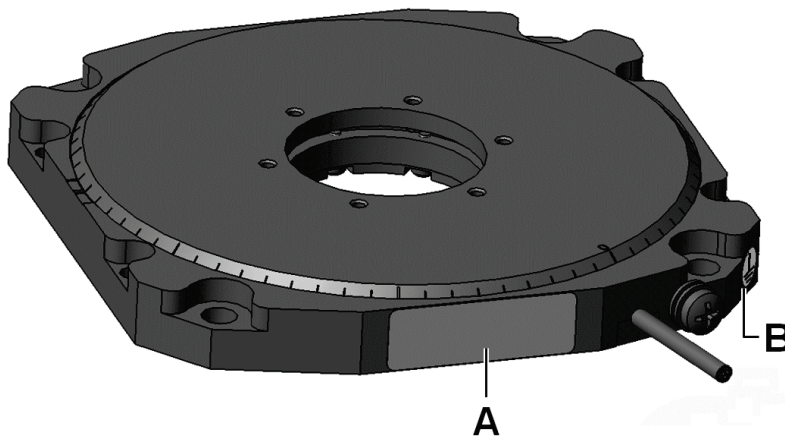

Figure 2: U-651: Position of the product labeling (example view)

Position	Labeling	Description
A		Manufacturer's logo
A		CE conformity mark
A		Warning sign "Observe manual!"
A	U-651.03	Product name (example), the characters following the period refer to the model
A	115064246	Serial number (example), individual for each U-651 Meaning of the places (counting from left): 1 = internal information 2 and 3 = year of manufacture 4 to 9 = consecutive numbers
A	WWW.PI.WS	Manufacturer's address (website)
A		Data matrix code (example; contains the serial number)
A		Old equipment disposal (p. 45)
A	Country of origin: Germany	Country of origin
B		Symbol for the protective earth conductor, marks the protective earth connection of the U-651 (p. 17)



Figure 3: U-651: "Residual Voltage" warning sign on connector
Warning sign "Residual voltage": Notice of risk of electric shock (p. 5)

3.4 Scope of Delivery

Item ID	Quantity	Components
U-651	1	Rotation stage according to order (p. 7)
000036450	1	M4 screw set for protective earth, consisting of: <ul style="list-style-type: none"> ▪ 1 M4x8 flat-head screw with cross recess, ISO 7045 ▪ 2 safety washers ▪ 2 flat washers
000055390	1	Screw set for mounting the U-651, consisting of: <ul style="list-style-type: none"> ▪ 5 socket head cap screws M6x20 ISO 4762 ▪ 1 Allen wrench AF 5.0
MP121EK	1	Short instructions for the PLine® stage

3.5 Suitable Controllers

Product number	Description
C-867.1U	Piezomotor controller / driver, networkable, 1 channel, for PLine® systems
C-877.2U12	Compact piezomotor controller / driver, 2 channels, for PLine® systems
C-867.10C885	Motion controller module for PLine® piezomotor systems with Sub-D connector(s), 1 axis, for PIMotionMaster

- To order, contact our customer service department (p. 33).

3.6 Accessories

Product number	Description
C-815.VF	Vacuum feedthrough, Sub-D 15-pin, including C815T0003 technical note
U-600.A01	Extension cable for PLine®, 15-pin Sub-D, 1 m*
U-600.A03	Extension cable for PLine®, 15-pin Sub-D, 3 m*
U-600.A05	Extension cable for PLine®, 15-pin Sub-D, 5 m*

* Other cable lengths available on request.

- To order, contact our customer service department (p. 33).

3.7 Technical Features

3.7.1 Rotary Encoder

The U-651 is equipped with an optical rotary encoder. For the encoder resolution, refer to the table in the "Specifications" section (p. 35).

Optical rotary encoders measure the actual position directly (direct metrology). Therefore, errors occurring in the drivetrain, such as nonlinearity, backlash or elastic deformation, cannot influence the measurement of the position.

3.7.2 Reference Point Switch

The U-651 has an optical reference point switch (see "Reference Switch Specifications", p. 36).

See the controller user manual and/or associated software manuals for the commands that make use of the reference point signal.

After a reference move of the U-651, the red dot on the moving platform is above the 0° mark in the base body.

3.7.3 ID Chip

The connector of the U-651 stages contains an ID chip. Information on the stage (e.g., type, serial number, date of manufacture, version of the hardware) is stored in parameters on the ID chip.

When switched on or rebooted, controllers from PI read the data from the ID chip.

For more information on the ID chip recognition, see the manual of the controller used.

4 Unpacking

INFORMATION

When handling the vacuum version of the rotation stage, attention must be paid to appropriate cleanliness. At PI, all parts are cleaned before assembly. During assembly and measurement, powder-free gloves are worn. In addition, the rotation stage is wipe cleaned afterwards and then shrink-wrapped twice in vacuum-compatible film.

- Only touch the rotation stage with powder-free gloves.
- If necessary, wipe the rotation stage clean after unpacking.

1. Unpack the U-651 with care.
2. Compare the contents with the items listed in the contract and the packing list.
3. Inspect the contents for signs of damage. If parts are missing or you notice signs of damage, contact PI immediately.
4. Keep all packaging materials in case the product needs to be returned.

5 Installation

In this Chapter

General Notes on Installation	15
Connecting the U-651 to the Protective Earth Conductor	17
Mounting the U-651 onto a Surface	18
Affixing the Load to the U-651.....	20
Connecting the Vacuum Version to the Controller	22

5.1 General Notes on Installation

CAUTION



Dangerous voltage and residual charge on piezo actuators!

Piezomotors are driven by piezo actuators. After disconnection from the electronics, piezo actuators can remain electrically charged for several hours. Temperature changes can also induce charges in piezo actuators. Touching or short-circuiting the contacts in the connector of the U-651 can lead to minor injuries from electric shock.

- Do **not** touch the contacts in the connector of the U-651.

NOTICE



Lubricants, dirt, condensation!

Dirt, oil, lubricants and condensation will render the motor/drive inoperable.

- Ensure that the piezomotors of the U-651 do not come into contact with lubricants.
- Keep the U-651 free from dirt and condensation.

NOTICE



Heating up of the U-651 during operation!

The heat produced during operation of the U-651 can affect your application.

- Install the U-651 so that your application is not affected by the dissipating heat.

NOTICE**Unsuitable cables!**

Unsuitable cables can cause damage to the controller and affect the performance of the U-651.

- Only use genuine PI parts to connect the U-651 to the controller.
- If you need longer cables, use extension cables from PI (p. 10).

NOTICE**Unintentional changes in position with vertical mounting!**

If the load exceeds the maximum torque of the drive when the rotation stage is mounted vertically, unintentional changes in the position of the moving platform occur. Unintentional changes in position of the moving platform can damage the drive, the load or the environment.

- When a rotation stage is mounted vertically, make sure that the installed load is lower than the maximum torque of the drive (p. 35).

INFORMATION

For optimum repeatability, all components must be firmly affixed to each other.

INFORMATION

When manually displacing the moving platform in a de-energized state, differences in the holding force may be noticeable across the travel range.

There are mechanical reasons for fluctuations in the holding force and they have no influence on the function of the stage.

- If possible, simulate the rotation stage motions with a mounted load or make suitable calculations in order to identify collisions or unfavorable center of gravity constellations.
- If necessary, take suitable constructive measures to avoid collisions and instabilities in the overall system.
- Avoid or mark danger zones that result from the installation of the rotation stage and the application in accordance with the legal regulations.

For more information on operating conditions, refer to the "Motor Power" section (p. 38).

5.2 Connecting the U-651 to the Protective Earth Conductor

INFORMATION

- Observe the applicable standards for connecting the protective earth conductor.

On the U-651, there is an M4 hole next to the cable exit for connecting the protective earth conductor. In the following figure, this hole is marked with the symbol for the protective earth conductor (⊕).

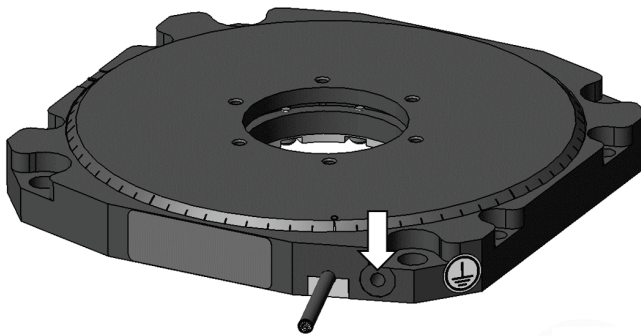

Figure 4: M4 threaded hole for connecting the protective earth conductor

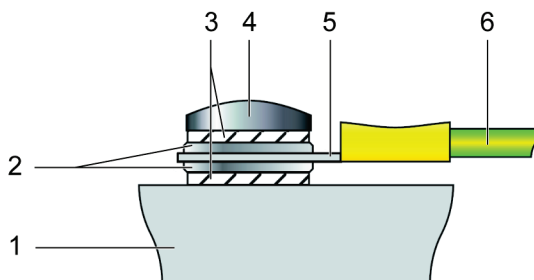

Figure 5: Connecting the protective earth conductor (profile view)

- 1 Base body of the U-651
- 2 Flat washer
- 3 Safety washer
- 4 Screw
- 5 Cable lug
- 6 Protective earth conductor

Requirements

- ✓ You have read and understood the general notes on installation (p. 15).
- ✓ The U-651 is **not** connected to the controller.

Tools and accessories

- Suitable protective earth conductor: Cross-sectional area of the cable $\geq 0.75 \text{ mm}^2$
- M4 screw set supplied for the connecting the protective earth conductor (p. 10)
- Suitable screwdriver

Connecting the U-651 to the protective earth conductor

1. If necessary, attach a suitable cable lug to the protective earth conductor.
2. Use the M4 screw (together with the washers and self-locking washers) to affix the cable lug of the protective earth conductor to the protective earth connection of the U-651 as shown in the profile view.
3. Tighten the M4 screw with a torque of 1.2 Nm to 1.5 Nm.
4. Make sure that the contact resistance at all connection points relevant for connecting the protective earth conductor is $< 0.1 \Omega$ at 25 A.

5.3 Mounting the U-651 onto a Surface

NOTICE**Warping of the base body!**

Incorrect mounting can warp the base body. Warping of the base body will increase wear and reduce accuracy.

- Mount the U-651 on an even surface. The recommended evenness of the surface is $10 \mu\text{m}$.
- For applications with large temperature changes:
Only affix the U-651 to surfaces that have the same or similar thermal expansion properties as the U-651 (e.g., surfaces made of aluminum).

INFORMATION

The positive direction of motion of the U-651 is shown in the product view (p. 8).

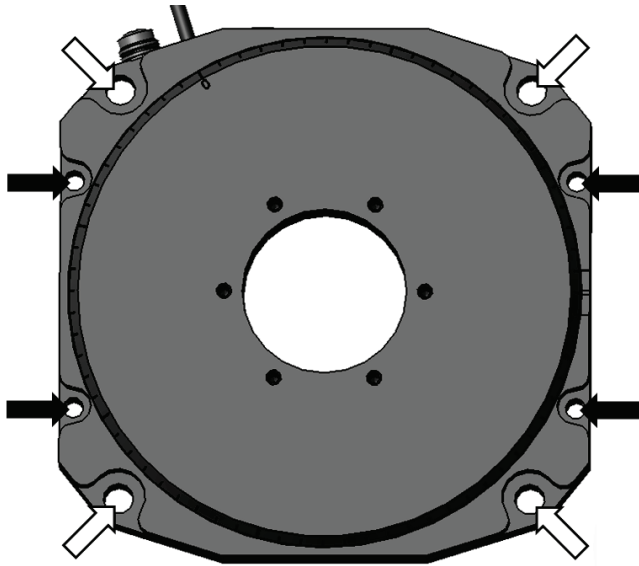

Figure 6: U-651: Holes in the base body for M6 screws (white arrows) or M4 screws (black arrows)

Requirements

- ✓ You have read and understood the general notes on installation (p. 15).
- ✓ You have provided a suitable surface (for the required position of the holes for accommodating the screws, see "Dimensions", p. 42).
 - Four M6 or M4 holes with a thread depth of at least 13 mm are present.
 - The evenness of the surface is $\leq 10 \mu\text{m}$.
 - For applications with large temperature changes: The surface should have the same thermal expansion properties as the U-651 (e.g., surface made of aluminum).
- ✓ You have accounted for the space required to route cables without bending and according to regulations.
- ✓ The U-651 is **not** connected to the controller.

Tools and accessories

- Mounting accessories in the scope of delivery (p. 10):
 - 4 M6 screws
 - Allen wrench
- Alternative (not in the scope of delivery):
 - 4 M4 screws of suitable length
 - Suitable screwdriver

Mounting the U-651 on a Surface

1. Align the U-651 on the surface so that the selected holes in the U-651 (see arrows in the figure) overlap with the the corresponding holes in the surface.
2. Insert four suitable screws into the selected holes in the base body of the U-651.
3. Tighten each of the four screws with the following torque:
 - M6 screws: 7.1 Nm
 - M4 screws: 2.1 Nm
4. Check that the U-651 is affixed firmly to the surface.

5.4 Affixing the Load to the U-651

NOTICE



Impermissibly high forces and torques!

Impermissibly high forces and torques that are applied to the moving platform can damage the U-651.

- For affixing type and mass of the load, observe the maximum permissible forces according to the specifications (p. 35).
- Avoid tilting torques >0.5 Nm on the moving platform.

NOTICE



Screws that are too long!

The U-651 can be damaged by screws that are too long.

- Note the depth of the mounting holes in the motion platform (p. 42).
- Only use screws of the correct length for the respective mounting holes.

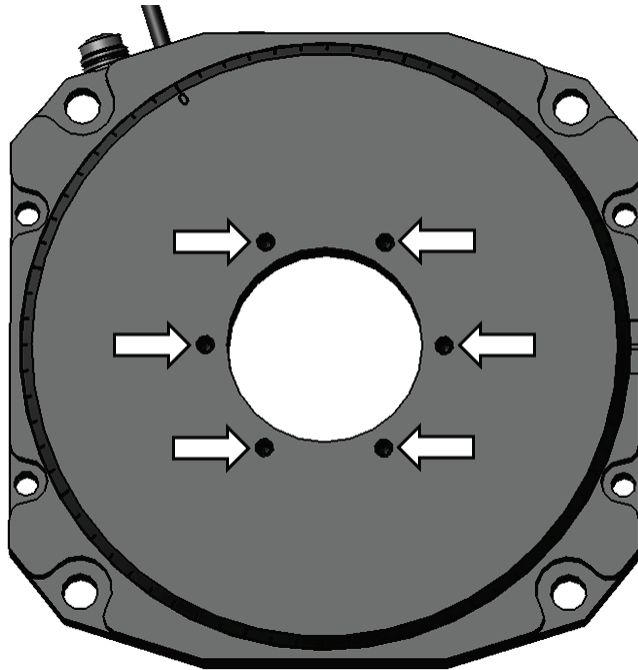

Figure 7: U-651, M3 holes for affixing the load

Requirements

- ✓ You have read and understood the general notes on installation (p. 15).
- ✓ You have properly attached the U-651 to a surface (p. 18).
- ✓ The U-651 is **not** connected to the controller.
- ✓ You have prepared the load so that it can be affixed to the mounting holes on the moving platform:
 - The distance between the center of gravity of the load and the center of the moving platform is as small as possible in all directions.
 - At least three points are provided for affixing the load on the moving platform.

Tools and accessories

- At least three M3 screws of suitable length (p. 42)
- Suitable tools for tightening the screws

Affixing the Load

1. Align the load on the U-651 so that the mounting holes in the load and the holes in the moving platform overlap.
2. Affix the load with at least three screws.
3. Check that the load is affixed firmly to the moving platform of the U-651.

5.5 Connecting the Vacuum Version to the Controller

For the vacuum version of the U-651, it is necessary to install a vacuum feedthrough (p. 10).

Requirements

- ✓ You have read and understood the general notes on installation (p. 15).
- ✓ The controller is **switched off**.
- ✓ You have connected the U-651 to the protective earth conductor (p. 17).
- ✓ You have read and understood the C815T0003 technical note for the C-815.VF vacuum feedthrough.

Tools and accessories

- C-815.VF vacuum feedthrough (p. 10), Sub-D 15
- U-600.A0x (p. 10) PLine® extension cable, Sub-D 15, 1 m to 5 m, air-side
- Suitable tools for installing the vacuum feedthrough

Installing the vacuum feedthrough

1. The dimensions of the vacuum feedthrough are in the C815T0003 technical note (see "shell size 2").
2. Provide a suitable opening for the vacuum chamber.
3. Install the vacuum feedthrough so that the Sub-D 15 (f) socket is in the vacuum chamber.

Connecting the vacuum version to the controller

- Connect the U-651 ("stage"), vacuum feedthrough and controller as shown in the connection diagram below.
 - Observe the assignment that is given by the labeling on the sockets, connectors and cables.

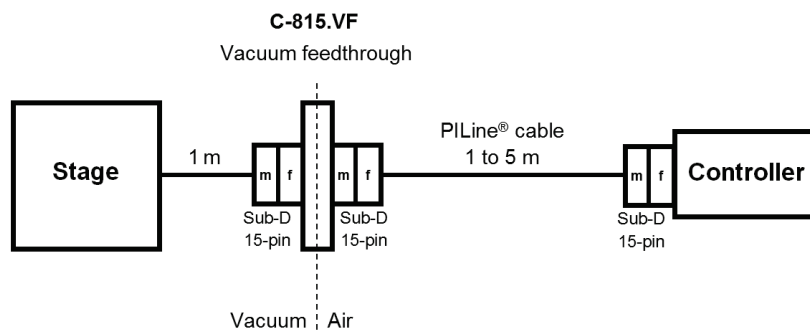

Figure 8: Connection of the vacuum version to the controller

6 Start-Up and Operation

In this Chapter

General Notes on Start-Up and Operation	23
Starting up the U-651.....	26

6.1 General Notes on Start-Up and Operation

CAUTION



Risk of electric shock if the protective earth conductor is not connected!

If a protective earth conductor is not or not properly connected, dangerous touch voltages can occur on the U-651 in the case of malfunction or failure of the system. If touch voltages exist, touching the U-651 can result in minor injuries from electric shock.

- Connect the U-651 to a protective earth conductor (p. 17) before start-up.
- Do **not** remove the protective earth conductor during operation.
- If the protective earth conductor has to be removed temporarily (e.g., in the case of modifications), reconnect the U-651 to the protective earth conductor before starting it up again.

NOTICE



Damage if an incorrect controller is connected!

Connecting a rotation stage to an unsuitable controller can cause damage to the rotation stage or controller.

- Only connect the rotation stage with PLine® ultrasonic piezomotors to PLine® controllers (p. 10).

NOTICE



Operating voltage too high or incorrectly connected!

Operating voltages that are too high or incorrectly connected can cause damage to the U-651.

- Only operate the U-651 with controllers/drivers and original accessories from PI.
- Do **not** exceed the operating voltage range (p. 36) for which the U-651 is specified.
- Only operate the U-651 when the operating voltage is properly connected; see "Pin Assignment" (p. 43).

NOTICE**Unintentional motion!**

Unintentional motion of the stage is possible when connecting the U-651 to the controller. Defective software or wrong operation of the software can also result in unintentional motion.

- Do not place any objects in areas where they can be caught by moving parts.
- Before connecting the U-651, check whether a macro is defined as the start-up macro in the controller and cancel the selection of the start-up macro if necessary.

NOTICE**Damage due to collisions!**

Collisions can damage the rotation stage, the load to be moved, and the surroundings.

- Make sure that no collisions are possible between the rotation stage, the load to be moved, and the surroundings in the motion range of the rotation stage.
- Do not place any objects in areas where they can be caught by moving parts.
- Stop the motion immediately if a controller malfunction occurs.
- If possible, adapt the travel range limits of your mechanical system in the software that you use for commanding the motion.

NOTICE**Uncontrolled oscillation!**

Your application can be damaged by uncontrolled oscillation of the U-651. If you encounter noise during operation:

- Immediately switch off the servo-control system of the affected axes.
- Check the settings of the servo-control parameters.

NOTICE**Overheating during continuous operation!**

The highest torque or holding force is reached at maximum motor power; however, the U-651 may overheat during continuous operation.

- Observe the recommended motor power depending on the duty cycle and the ambient temperature (p. 40).

NOTICE**Damage or considerable wear due to high accelerations!**

High accelerations can cause damage to or considerable wear on the mechanical system.

- Stop the motion immediately if a controller malfunction occurs.
- Determine the maximum velocity for your application.
- Observe the information in the "Motor Power" section (p. 38).

INFORMATION

Although the U-651 operates quietly in theory, noise levels of up to 50 dB (A) are possible during operation. The ultrasonic drive of the U-651 can also generate higher noise levels at frequencies between 100 and 500 kHz.

INFORMATION

The positive direction of motion of the U-651 is shown in the product view (p. 8).

INFORMATION

For maximum force generation, a run-in procedure is necessary during the start-up of the U-651 and after longer downtimes; see also "Influence of Downtimes on the Torque" (p. 41). The U-651 reaches its maximum torque after the run-in procedure.

- For run-in, command a few motion cycles at low velocity. The motion cycles should comprise full revolutions if possible.

INFORMATION

In a vacuum, there is no heat dissipation via convection.

- Operate the vacuum version of the U-651 with 20 % lower motor power than specified in "Motor power and lifetime" (p. 40) or reduce the duty cycle.

For more information on operating conditions, refer to the "Motor Power" section (p. 38).

6.2 Starting up the U-651

NOTICE



Incorrect parameter settings!

If you use the software that is included in the scope of delivery of the controller (p. 10), the operating parameters of the U-651 can be loaded from a stage database. The stage database contains the default parameter values of your rotation stage for performing initial test motions during start-up. Depending on the application, using the default parameter values (e. g., for P term, I term, D term, acceleration and velocity) can cause damage to the rotation stage, especially when operated with heavy loads.

- If possible: Perform the first start-up without a load.
- Always install the latest version of the stage database onto your PC.

For start-up with a load:

- Before start-up, make sure that the U-651 has been properly installed (p. 15).
- For optimum performance of the moving axis, adjust the operating parameters of the controller (e.g., P term, I term, D term, acceleration, velocity; see controller manual).
- Save the new parameter values to a stage database on the PC or to the nonvolatile memory of the controller for future use (see controller manual and PIMikroMove manual).

INFORMATION

If the total cable length between the stage and the controller is more than 3 m, it is necessary to adjust the parameter values in the controller for optimum motor power. The default parameter values in the stage database are suitable for a total cable length of 3 m.

Total cable length of 3 m to 6.5 m:

1. Adjust the value of the **Frequency Shift** parameter (ID 0x64) in the controller. Possible values: 20, 15, 10, 5, 0, -5, -10, -15, -20.
2. Repeat step 1 until the U-651 has reached optimum motor power.
3. Save the new parameter values to a stage database on the PC or the nonvolatile memory of the controller for future use (see controller manual and PIMikroMove manual).

Total cable length >6.5 m:

- Contact our customer service department (p. 33).

Requirements

- ✓ You have read and understood the general notes on start-up and operation (p. 23).
- ✓ You have read and understood the user manual of the controller (p. 3).
- ✓ In the case of start-up with a load: The U-651 has been properly installed (p. 15).
- ✓ The controller (p. 10) and the required software have been installed. All connections on the controller have been set up (see controller manual).

Starting up the U-651

- Start up the axis (see controller manual).
Start-up involves the following steps:
 - Selecting the stage type
 - Defining the reference point of the axis
 - Commanding initial motions in closed-loop operation for testing and for run-in of the mechanical system

The controller manual describes start-up using the PIMikroMove program.

7 Maintenance

In this Chapter

General Notes on Maintenance.....	29
Performing a Maintenance Run.....	29
Cleaning the U-651	30

7.1 General Notes on Maintenance

NOTICE



Damage due to improper maintenance!

Improper maintenance can result in the failure of the U-651.

- Only loosen screws according to the instructions in this manual.
- Ensure that the piezomotors of the U-651 do not come into contact with lubricants.

7.2 Performing a Maintenance Run

Depending on the operating conditions and the period of use of the U-651, a maintenance run may be required. The maintenance run is performed to redistribute the existing lubricant in the bearing of the U-651. The stage must rotate by at least one full revolution during the maintenance run.

- To evenly distribute the existing lubricant in the stage bearing, perform a maintenance run after 500 hours of operation or after 1 year at the latest.
- If you move your U-651 over a small working range (<math><20^\circ</math>) in continuous industrial operation, perform a maintenance run after every 5000 motion cycles.

7.3 Cleaning the U-651

Requirements

- ✓ You have disconnected the rotation stage from the controller.

Cleaning the rotation stage

Only when the rotation stage is **not** used in vacuum:

- If necessary, clean the surfaces of the rotation stage with a cloth that is lightly dampened with a mild cleanser or disinfectant.

Only when the rotation stage is used in vacuum:

- Only touch the rotation stage with powder-free gloves.
- If necessary, wipe the rotation stage clean.

8 Troubleshooting

Problem	Possible causes	Solution
Noise during operation	Uncontrolled oscillation of the U-651	<ul style="list-style-type: none"> ➤ Immediately switch off the servo-control system of the affected axes. ➤ Check the settings of the servo-control parameters.
Rotation stage positions inaccurately	Settling window around the target position is too large	<ul style="list-style-type: none"> ➤ Reduce the settling window by changing the parameter values for the settling window limits on the controller. See the controller user manual (p. 3) for details.
Reaching the target position takes too long	Settling window around the target position is too small	<ul style="list-style-type: none"> ➤ Enlarge the settling window by changing the parameter values for the settling window limits on the controller. See the controller user manual (p. 3) for details.
Increased wear Reduced accuracy	Warped base body	<ul style="list-style-type: none"> ➤ Mount the U-651 on an even surface. The recommended evenness of the surface is 10 µm. ➤ For applications with large temperature changes: Only mount the U-651 on surfaces that have the same or similar thermal expansion properties as the U-651 (e.g., surfaces made of aluminum).
No or limited motion	Excessive load	<ul style="list-style-type: none"> ➤ Reduce the load (see "Data Table", p. 35). ➤ When the rotation stage is mounted vertically, make sure that the installed load is lower than the maximum torque of the drive (p. 35).
	The default parameter values are not suitable for operating with high loads	<ul style="list-style-type: none"> ➤ Adjust the operating parameters according to the description in "Starting up the U-651".
	The default parameter values are not suitable for cables longer than 3 m	<ul style="list-style-type: none"> ➤ Adjust the operating parameters according to the description in "Starting up the U-651".

If the problem that occurred with your system is not listed in the table above or cannot be solved as described, contact our customer service department (p. 33).

9 Customer Service

For inquiries and orders, contact your PI sales engineer or send us an email (info@pi.ws).

- If you have questions concerning your system, have the following information ready:
 - Product and serial numbers of all products in the system
 - Firmware version of the controller (if present)
 - Version of the driver or the software (if present)
 - Operating system on the PC (if present)
- If possible: Take photographs or make videos of your system that can be sent to our customer service department if requested.

The latest versions of the user manuals are available for download (p. 3) on our website.

10 Technical Data

In this Chapter

Specifications	35
Ambient Conditions and Classifications.....	37
Motor Power.....	38
Dimensions	42
Pin Assignment	43

10.1 Specifications

10.1.1 Data Table

	U-651.03 / U-651.03V	U-651.04 / U-651.04V	Unit	Tolerance
Motion and positioning				
Active axes	θ_z	θ_z		
Rotation range	>360	>360	°	
Velocity, closed-loop	540	540	°/s	max.
Minimum incremental motion	27	12	μrad	typ.
Bidirectional repeatability	± 54	± 24	μrad	
Sensor				
Sensor type	Incremental encoder	Incremental encoder		
Sensor resolution	9	4	μrad	
Mechanical load capacity				
Load capacity / axial force	20	20	N	max.
Holding torque	0.3	0.3	Nm	max.
Drive properties				
Motor type	PILine® ultrasonic piezomotor, performance class 2	PILine® ultrasonic piezomotor, performance class 2		
Drive torque clockwise / counterclockwise (θ_z)	0.3	0.3	Nm	max.
Connectors				
Motor/Sensor	1 × Sub-D, 15-pin (m)	1 × Sub-D, 15-pin (m)		

	U-651.03 / U-651.03V	U-651.04 / U-651.04V	Unit	Tolerance
Miscellaneous				
Reference point switch	Optical	Optical		
Operating temperature	0 to 40	0 to 40	°C	
Material	Al (black anodized)	Al (black anodized)		
Mass	500	500	g	±5 %
Cable length	1.5 (Model .03) 1.0 (Model .03V)	1.5 (Model .04) 1.0 (Model .04V)	m	±10 %

Ask about custom designs!

10.1.2 Reference Point Switch Specifications

Type	Optical sensor
Supply voltage	+5 V/GND, supply via the motor connector
Signal output	TTL level

10.1.3 Maximum Ratings

The U-651 rotation stages are designed for the following operating data:

Maximum operating voltage	Operating frequency	Maximum power consumption
200 V _{pp} or 71 V _{eff}	152 to 165 kHz	30 W

10.1.4 Specifications for Vacuum-Compatible Versions

The following vacuum-compatible components are used for the vacuum version of the U-651:

Component	Material
Mechanical parts	Aluminum (blank), aluminum (anodized, black, matt), steel, ceramic (PIC181, Al ₂ O ₃), PEEK, PTFE
Cable	FEP; ribbon cable (FFC) from Axon Kabel GmbH
Shrink tubing	PVDF (Kynar)
Connector	Sub-D 15 (m)
Insulation	KU-THE-150
Lubricant	Molykote HP-300

Component	Material
Sealant	Scotch Weld
Adhesives	Epoxy resin-based adhesive

Bakeout temperature: 80°C (176°F)

Bakeout time: 3 hours

10.2 Ambient Conditions and Classifications

The following ambient conditions and classifications for the U-651 must be observed:

Area of application	For indoor use only
Maximum altitude	2000 m
Air pressure	1100 hPa to 0.1 hPa
Relative humidity	Highest relative humidity 80 % for temperatures up to 31 °C Decreasing linearly to 50 % relative humidity at 40 °C
Operating temperature	0°C to 40°C
Storage temperature	-20 °C to 75 °C
Transport temperature	-20 °C to 75 °C
Overvoltage category	II
Protection class	I
Degree of pollution	1
Degree of protection according to IEC 60529	IP20

10.3 Motor Power

10.3.1 Motor Power and Operating Voltage

INFORMATION

The operating voltage is limited by the controller using the **Maximum Motor Output (V)** (ID 0x7c) parameter. If you load the operating parameters of the U-651 from the stage database, the parameter is set to the maximum permissible value.

The following table shows the relationship between the operating voltage and the motor power of the U-651. The operating voltage is output by the controller and depends on the actual control value. The polarity sign of the control value determines the direction of motion.

Motor power	Operating voltage (rounded)	Corresponding control value on the controller*
0 %	0 V _{eff}	0
25 %	18 V _{eff}	8192 or -8192
50 %	36 V _{eff}	16384 or -16384
75 %	53 V _{eff}	24575 or -24575
100 %	71 V _{eff} (max.)	32767 or -32767

* Generated in closed-loop operation via the control algorithm or set in open-loop operation via the `SMO` command.

For further information, see the user manual of the controller (p. 3) used to operate the U-651.

10.3.2 Velocity and Torque

The following figure can be used to estimate the velocity and torque of the U-651 with different motor powers. Motion is possible starting at a motor power of approx. 30 %.

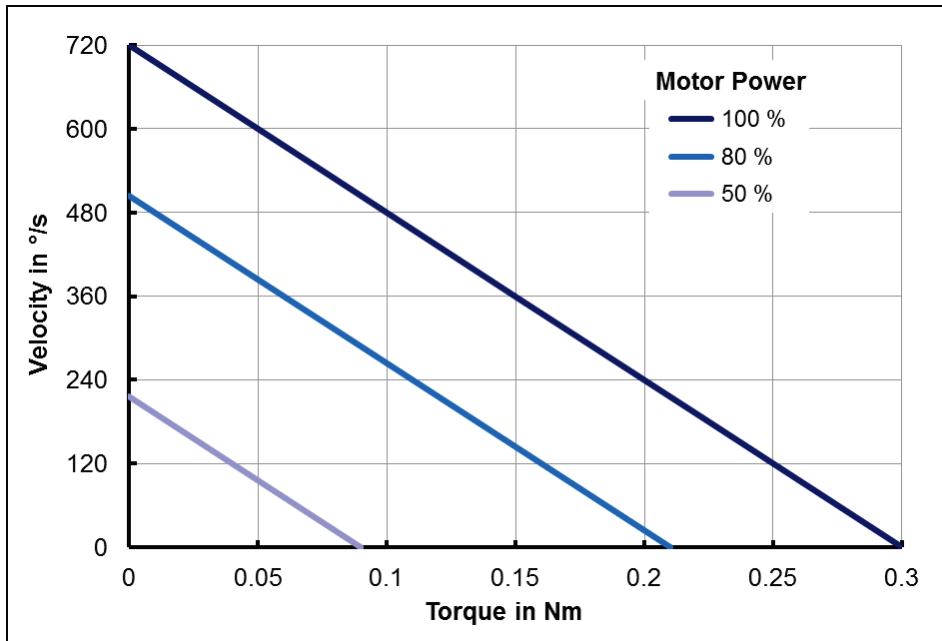

Figure 9: Relationship between velocity and torque of the U-651 with different motor power levels

10.3.3 Motor Power and Lifetime

Motor power, duty cycle and ambient temperature influence the lifetime of the rotation stage. In order to prevent overheating and high wear, the motor power and the duty cycle should not exceed the limits given in the following graph. A load cycle corresponds to a positioning run and includes the acceleration, motion, deceleration as well as downtime (break). The motor should only sporadically be operated at peak power; the peak power serves as a control reserve.

INFORMATION

In a vacuum, there is no heat dissipation via convection.

- Operate the vacuum version of the U-651 with a 20 % lower motor power than given in the graph, or reduce the duty cycle.

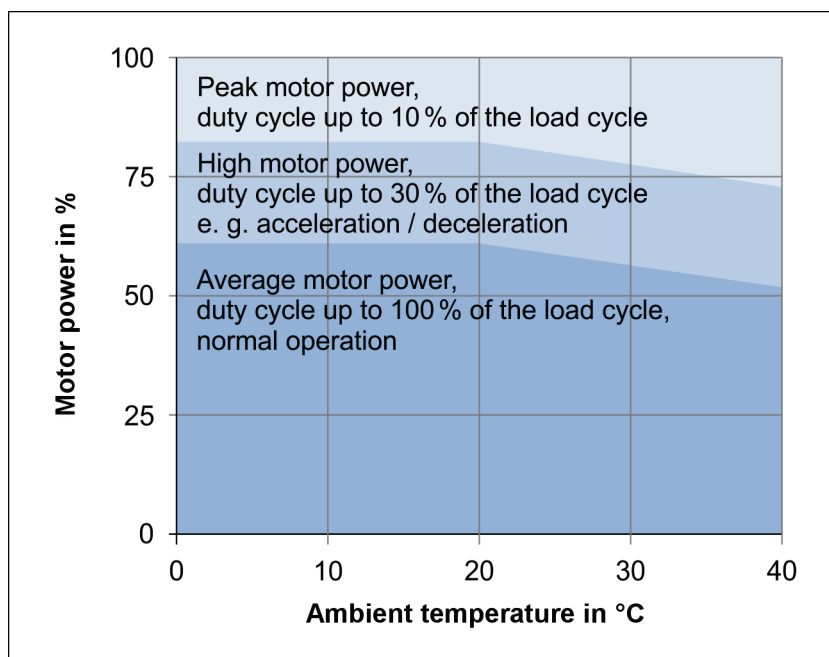

Figure 10: U-651: Recommended duty cycle and motor power depending on the ambient temperature

10.3.4 Influence of Downtimes on the Torque

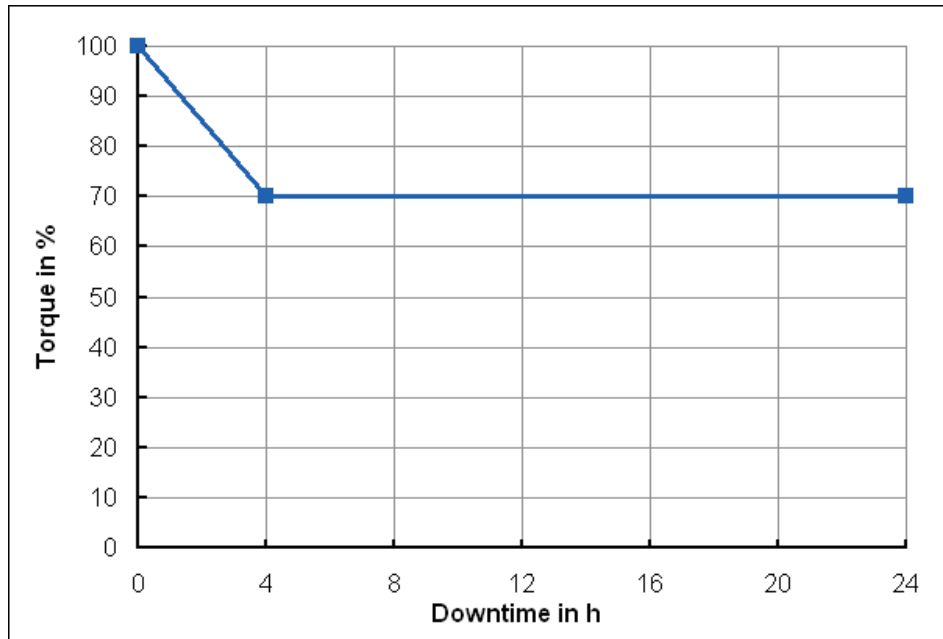

Figure 11: Torque of the U-651 depending on the downtime of the motor

10.4 Dimensions

Dimensions in mm. Note that the decimal places are separated by a comma in the drawings.

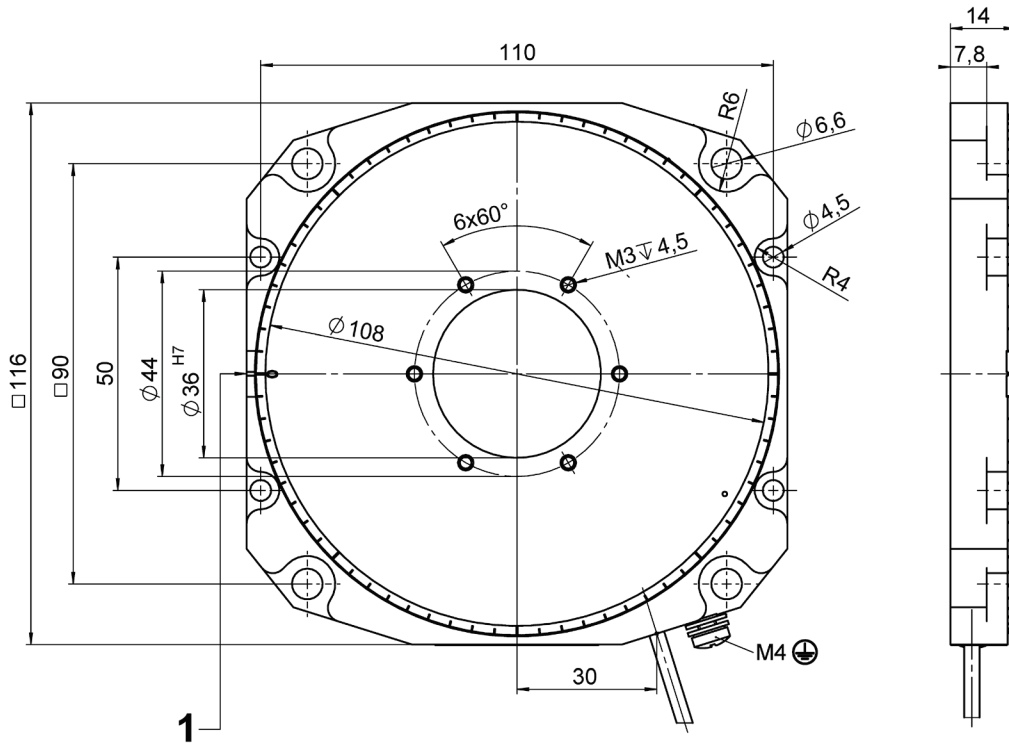

Figure 12: U-651: Dimensions and position of the 0° mark [1] after the reference point definition

10.5 Pin Assignment

Connector: Sub-D 15 (m)

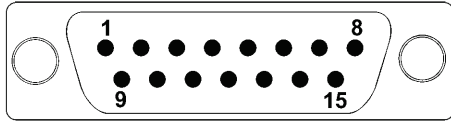

Figure 13: Front view of the Sub-D 15 connector

Pin	Signal	Function
1	NC	Not connected
2	USM_P1	Input: Piezo 71 VAC (RMS)
3	USM_P2	Input: Piezo 71 VAC (RMS)
4	VDD	Input: +5 V
5	NC	Not connected
6	ID_CHIP	Bidirectional: Data line for ID chip
7	ENCA-	Output: Encoder channel A (inverted), RS-422
8	ENCB-	Output: Encoder channel B (inverted), RS-422
9	USM_P1	Input: Piezo 71 VAC (RMS)
10	GND	0 V
11	USM_P3	Input: Piezo 71 VAC (RMS)
12	NC	Not connected
13	REFSWITCH	Output: Reference point switch
14	ENCA+	Output: Encoder channel A, RS-422
15	ENCB+	Output: Encoder channel B, RS-422

11 Old Equipment Disposal

In accordance with EU law, electrical and electronic equipment may not be disposed of in EU member states via the municipal residual waste.

Dispose of your old equipment according to international, national, and local rules and regulations.

In order to fulfil its responsibility as the product manufacturer, Physik Instrumente (PI) GmbH & Co. KG undertakes environmentally correct disposal of all old PI equipment made available on the market after 13 August 2005 without charge.

Any old PI equipment can be sent free of charge to the following address:

Physik Instrumente (PI) GmbH & Co. KG
Auf der Roemerstr. 1
D-76228 Karlsruhe, Germany



12 EC Declaration of Conformity

For the U-651, an EC Declaration of Conformity has been issued in accordance with the following European directives:

Low Voltage Directive

EMC Directive

RoHS Directive

The applied standards certifying the conformity are listed below.

Safety (Low Voltage Directive): EN 61010-1

EMC: EN 61326-1

RoHS: EN 50581

