



Visualisation; Diagnostics

Easy to Configure

Programming IEC 61131-3

Rapid Installation

PSEN ml s 1.1

PILZ

THE SPIRIT OF SAFETY

► PSEN sensor technology

This document is the original document.

All rights to this documentation are reserved by Pilz GmbH & Co. KG. Copies may be made for the user's internal purposes. Suggestions and comments for improving this documentation will be gratefully received.

Source code from third-party manufacturers or open source software has been used for some components. The relevant licence information is available on the Internet on the Pilz homepage.

Pilz®, PIT®, PMI®, PNOZ®, Primo®, PSEN®, PSS®, PVIS®, SafetyBUS p®, SafetyEYE®, SafetyNET p®, the spirit of safety® are registered and protected trademarks of Pilz GmbH & Co. KG in some countries.



SD means Secure Digital

Section 1	Introduction	5
	1.1 Validity of documentation	5
	1.2 Using the documentation	5
	1.3 Definition of symbols	5
Section 2	Safety	7
	2.1 Intended use	7
	2.2 Safety regulations	8
	2.2.1 Safety assessment	8
	2.2.2 Additional documents that apply	8
	2.2.3 Use of qualified personnel	8
	2.2.4 Warranty and liability	9
	2.2.5 Disposal	9
	2.3 For your safety	9
Section 3	Overview	10
	3.1 Unit features	10
	3.2 Scope of supply	10
Section 4	Function description	11
	4.1 Structure	11
	4.2 Activation of safety inputs S31 and S41 (solenoid operation)	12
	4.2.1 Activation with specification of direction	14
	4.2.2 Activation without specification of direction	14
	4.3 Safety Device Diagnostics	15
	4.4 Operating modes	15
	4.5 Block diagram	19
	4.6 Auxiliary release	19
	4.6.1 Recommissioning	21
	4.7 Prevent restart	21
	4.8 Escape release	22
	4.8.1 Recommissioning	23
Section 5	Wiring	24
	5.1 Important information	24
	5.2 Pin assignment, connector and cable	24
	5.3 EMC requirements	25
Section 6	Connection to control systems and evaluation devices	26
	6.1 Important information	26
	6.2 Minimum requirements for activation of guard locking	26
	6.3 Single connection	28
	6.4 Series connection	29
	6.5 Connection to Pilz evaluation devices	32
	6.5.1 Connection example with PNOZmulti and Safety Device Diagnostics	33

Section 7	Teaching in the actuator	34
	7.1 PSEN ml 1.1	34
Section 8	Installation	35
	8.1 Important information	35
	8.2 Tapped hole	36
	8.3 Install fixing screws in parallel to actuator	38
	8.4 Install fixing screws side-on to actuator	38
	8.5 Centre the bolt in the actuator housing	39
	8.6 Rotate the bolt in the actuator housing 90°	39
	8.7 Installation on sliding gate	41
	8.8 Installation on swing gate	42
	8.9 Installation with mounting bracket	44
	8.10 Installation with mounting plate	44
	8.11 Installing the escape release	45
	8.11.1 Important information	45
	8.11.2 Installation positions for escape release	46
	8.11.3 Installation stationary escape release	47
	8.11.4 Installation external escape release	49
	8.11.5 Uninstalling the escape release	52
Section 9	Adjustment	53
Section 10	Operation	54
	10.1 Normal mode	54
	10.2 Error display	56
Section 11	Checks and maintenance	57
Section 12	Dimensions	58
Section 13	Technical details	65
	13.1 Classification according to ZVEI, CB24I	68
	13.2 Safety characteristic data	69
Section 14	Supplementary data	70
	14.1 Radio approval	70
	14.2 Technical details for mounting bracket without handle unit	70
	14.3 Technical details for mounting bracket with handle unit	70
Section 15	Order reference	71
	15.1 System	71
	15.2 Accessories	71
Section 16	Appendix	75
Section 17	EC declaration of conformity	76

1 Introduction

1.1 Validity of documentation

This documentation is valid for the product PSEN ml s 1.1 from Version 2.0.

This operating manual explains the function and operation, describes the installation and provides guidelines on how to connect the product.

1.2 Using the documentation

This document is intended for instruction. Only install and commission the product if you have read and understood this document. The document should be retained for future reference.

1.3 Definition of symbols

Information that is particularly important is identified as follows:



DANGER!

This warning must be heeded! It warns of a hazardous situation that poses an immediate threat of serious injury and death and indicates preventive measures that can be taken.



WARNING!

This warning must be heeded! It warns of a hazardous situation that could lead to serious injury and death and indicates preventive measures that can be taken.



CAUTION!

This refers to a hazard that can lead to a less serious or minor injury plus material damage, and also provides information on preventive measures that can be taken.



NOTICE

This describes a situation in which the product or devices could be damaged and also provides information on preventive measures that can be taken. It also highlights areas within the text that are of particular importance.

**INFORMATION**

This gives advice on applications and provides information on special features.

2 Safety

2.1 Intended use

The safety gate system is used for interlocking and guard locking swing gates and sliding gates.

The safety gate system can be operated in two ways:

- ▶ Unlocking with condition

The safety gate system prevents the safety gate from being unlocked while there is any hazard within the danger zone.

- ▶ Unlocking without condition

The operator can unlock the safety gate system at any time. After starting the unlocking, the guard locking creates a stop command. The time required to unlock the interlocking guard has to be longer than the time required to stop the hazardous machine function.

The hazardous machine function may only be executed under the following conditions:

- ▶ There is a high signal at safety outputs 12 and 22 and
- ▶ There is a low signal at safety outputs S31 (Lock/Unlock Request 1) and S41 (Lock/Unlock Request 2).

Safety inputs S31 and S41 (solenoid operation) may only be operated under the following condition:

- ▶ Plant is in a safe condition

Make sure that this is the case with an AND operation in the safety system immediately before the output is operated.

The safety switch meets the requirements in accordance with:

- ▶ EN 60947-5-3 with the actuator PSEN ml 1.1: PDDDB
- ▶ EN 62061: SIL CL 3
- ▶ EN ISO 13849-1: PL e (Cat. 4)
- ▶ EN ISO 14119: Coding level Low, type 4

The safety switch may only be used with the corresponding actuator PSEN ml 1.1.

The safety level PL e (Cat. 4)/SIL CL 3 is only achieved if

- ▶ the safety outputs use 2-channel processing
- ▶ The solenoid has 2-channel operation via safe, tested outputs, suitable for PL e (Cat. 4)/SIL CL 3 applications.

With 1-channel operation of the safety inputs S31 (Lock/Unlock Request 1) and S41 (Lock/Unlock Request 2) it is only possible to achieve safety level PL d (Cat. 2)/SIL CL 2.

Foreseeable misuse

- ▶ Safety switches and actuators of the safety gate system PSEN ml s 1.1 must **not** be used as mechanical limit stops
- ▶ Use of the PSEN ml s 1.1 under corrosive environmental conditions (cooling emulsions, surface treatment, gases, ...)

Please contact Pilz.

2.2 Safety regulations

2.2.1 Safety assessment

Before using a device it is necessary to perform a safety assessment in accordance with the Machinery Directive.

Functional safety is guaranteed for the product as a single component. However, this does not guarantee the functional safety of the overall plant/machine. In order to achieve the required safety level for the overall plant/machine, define the safety requirements for the plant/machine and then define how these must be implemented from a technical and organisational standpoint.

2.2.2 Additional documents that apply

Please read and take note of the following documents.

Only for use of the Safety Device Diagnostics (SDD):

- ▶ Operating manual for the fieldbus module, for example SDD ES ETH or SDD ES PROFIBUS
- ▶ System description "Safety Device Diagnostics"

For the use of passive junctions:

- ▶ Operating manual of a passive junction, for example:
 - PSEN ix2 F4 code
 - PSEN ix2 F8 code
 - PDP67 F 4 code

You will need to be conversant with the information in these documents in order to fully understand this operating manual.

2.2.3 Use of qualified personnel

The products may only be assembled, installed, programmed, commissioned, operated, maintained and decommissioned by competent persons.

A competent person is a qualified and knowledgeable person who, because of their training, experience and current professional activity, has the specialist knowledge required. To be able to inspect, assess and operate devices, systems and machines, the person has to be informed of the state of the art and the applicable national, European and international laws, directives and standards.

It is the company's responsibility only to employ personnel who

- ▶ Are familiar with the basic regulations concerning health and safety / accident prevention,
- ▶ Have read and understood the information provided in the section entitled Safety
- ▶ Have a good knowledge of the generic and specialist standards applicable to the specific application.

2.2.4 Warranty and liability

All claims to warranty and liability will be rendered invalid if

- ▶ The product was used contrary to the purpose for which it is intended,
- ▶ Damage can be attributed to not having followed the guidelines in the manual,
- ▶ Operating personnel are not suitably qualified,
- ▶ Any type of modification has been made (e.g. exchanging components on the PCB boards, soldering work etc.).

2.2.5 Disposal

- ▶ In safety-related applications, please comply with the mission time T_M in the safety-related characteristic data.
- ▶ When decommissioning, please comply with local regulations regarding the disposal of electronic devices (e.g. Electrical and Electronic Equipment Act).

2.3 For your safety



WARNING!

Loss of safety function due to substituting an actuator from the interlocking and guard locking system

Substituting an actuator for an inappropriate actuator may lead to serious injury and death.

- You should prevent the interlocking and guard locking system from being manipulated with an inappropriate actuator.
- Keep the substitute actuator in a safe place and protect it from unauthorised access.
- If substitute actuators are used, these must be installed as described under [Installation](#) [ 35]
- If the original actuators are replaced with substitute actuators, the original actuators must be destroyed before disposal.

- ▶ Do not remove the connector's protective cap until you are just about to connect the unit. This will prevent potential contamination.

3 Overview

3.1 Unit features

- ▶ Safe guard locking for swing gates and sliding gates
- ▶ Safe interlocking (position monitoring)
- ▶ Transponder technology
- ▶ 2 safety inputs for series connection of multiple safety switches
- ▶ 2 safety outputs
- ▶ Safety Device Diagnostics (SDD)
 - Safety Device Diagnostics can be used to poll sensor information, to perform actions and to read configuration parameters
 - Manipulation protection in accordance with ISO 14119 (chap. 7.2.d) is possible by verifying the short name of the actuator through the controller via SDD communication
- ▶ Diagnostic input for Y1 for Safety Device Diagnostics (SDD)
- ▶ Signal output/diagnostic output Y32 for Safety Device Diagnostics
- ▶ Monitoring of shorts between the safety outputs
- ▶ Guard locking element keeps the safety gate from being opened unintentionally
- ▶ Auxiliary release for opening the safety gate
- ▶ 1 signal output
- ▶ Suitable for left and right hinged safety gates
- ▶ Pilz coding type: Coded
- ▶ M12, 12-pin male connector
- ▶ LEDs:
 - Supply voltage/fault
 - Status of actuator
 - Status of guard locking
 - Status of safety inputs S11 and S21
- ▶ The bolt in the actuator can be rotated 90° in the actuator housing before the actuator is installed. As a result, the actuator can be installed vertically or horizontally.
- ▶ The safety switch PSEN ml s 1.1 can be expanded using a stationary or external escape release (see [Order reference: Accessories](#) [ 71]).

The stationary escape release can be expanded by 25 mm max. two times.

The external escape releases are available with push/pull cables between 1.5 and 4 m in length (grading 50 cm).

3.2 Scope of supply

- ▶ Scope of supply PSEN ml s 1.1
 - Safety switch PSEN ml s 1.1
 - Actuator

4 Function description

4.1 Structure

The interlocking and guard locking system prevents the safety gates to the danger zone from being opened while there is any hazard within the danger zone (machine movement, voltage, ...).

The safety outputs may have a high or low signal, depending on the position of the actuator and the signal path of safety inputs S31 and S41 (solenoid operation).

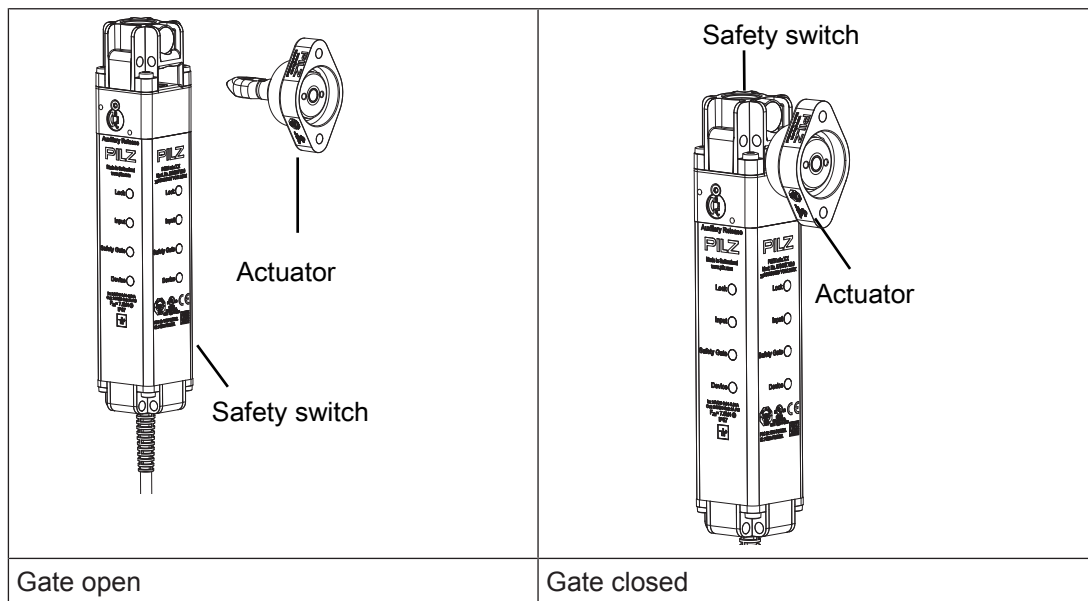

Safety outputs 12 and 22

Under these conditions there is a high signal at safety outputs 12 and 22:

- ▶ Actuator is detected **and**
- ▶ Guard locking pin has successfully been activated (guard locking pin is in the locked position) **and**
- ▶ There is a high signal at the inputs S11 and S21

If one of these conditions is not met, the signal at the safety outputs will be low.

Feasibility monitoring for safety inputs S11 and S21

- ▶ If one safety input switches from high to low, while the other safety input remains high, an unequal status is displayed: **Input LED flashes yellow**
- ▶ If this safety input switches back from low to high, while the other safety input remains high, a feasibility error is displayed and a partial operation lock is triggered: **Input LED flashes yellow**

A switch to a high signal will only lead to normal switch operation if both inputs had a low signal. From this moment on, the switch to high may occur (partial operation lock see [Error display](#) [56]).

- ▶ Diagnostic input Y1
If a fieldbus module of the SDD is used, the diagnostic input Y1 is automatically activated and data is read.
If no fieldbus module of the SDD is used, the diagnostic input Y1 is not used.
- ▶ Signal output/diagnostic output Y32
The status of the actuator is output. If a fieldbus module of the SDD is used, the signal output/diagnostic output for the writing of data is activated.

4.2 Activation of safety inputs S31 and S41 (solenoid operation)

- ▶ If there is a low signal at safety inputs S31 and S41, the guard locking pin does not change its position.
- ▶ Guard locking may only be deactivated once the hazardous movement has been completed.

Active use of Safety Device Diagnostics

- ▶ The safety inputs S31 and S41 have a high signal within max. 500 ms after the receipt of the guard locking activation.

Single connection

Guard locking is activated through a high signal (length 350 - 400 ms) at inputs S31 and S41 (solenoid operation). After activation, the inputs must be low. Another pulse (length 350 - 400 ms) at these inputs deactivates guard locking.

Series connection

In a series connection with n safety switches the safety lock is activated by a high signal with a minimum length of $t = n * (350 - 400 \text{ ms})$ at the inputs S31 and S41 (solenoid operation).

Number of safety switches in the series connection	Pulse duration Lock/Unlock Request in ms
1	350
2	700
3	1050
4	1400
5	1750
6	2100

After activation, the inputs must be low. Another pulse of the specified length at these inputs deactivates guard locking.

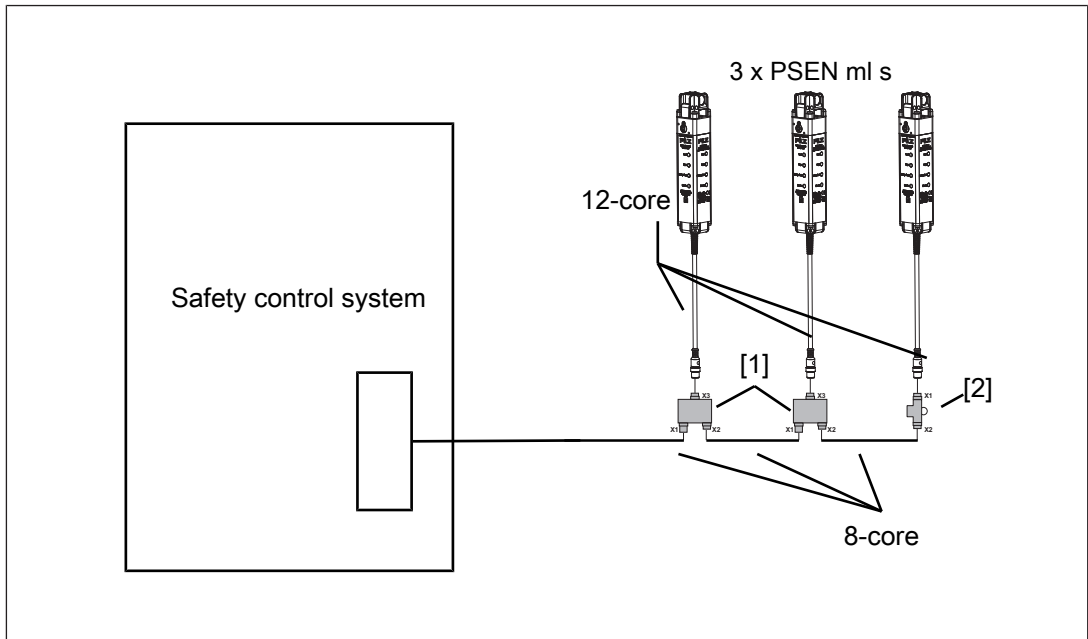

Legend

[1] PSEN ml Y junction M12

[2] PSEN ml end adapter

- ▶ Series connection of the OSSD outputs

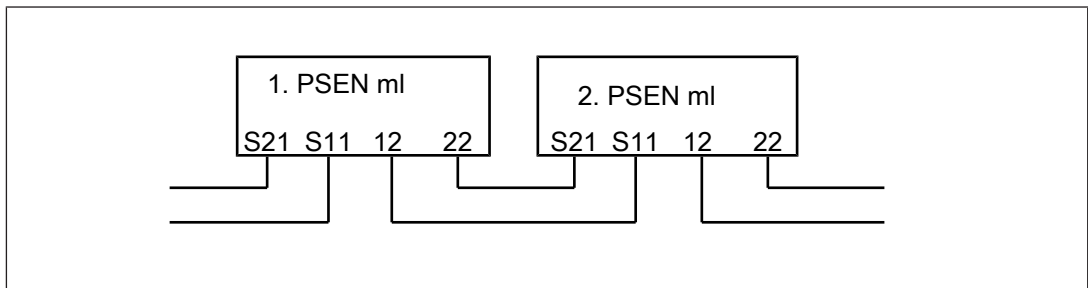

- ▶ Series connection of diagnostics with Safety Device Diagnostics

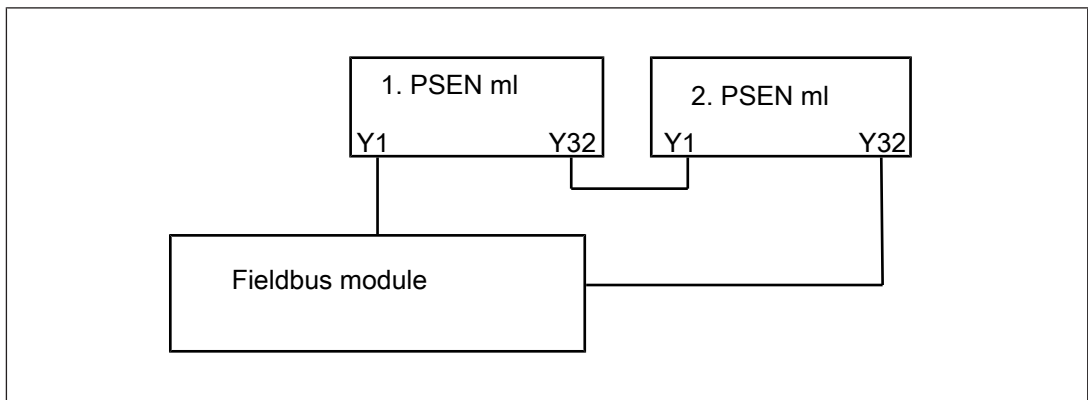

- ▶ Series connection of the solenoid operation

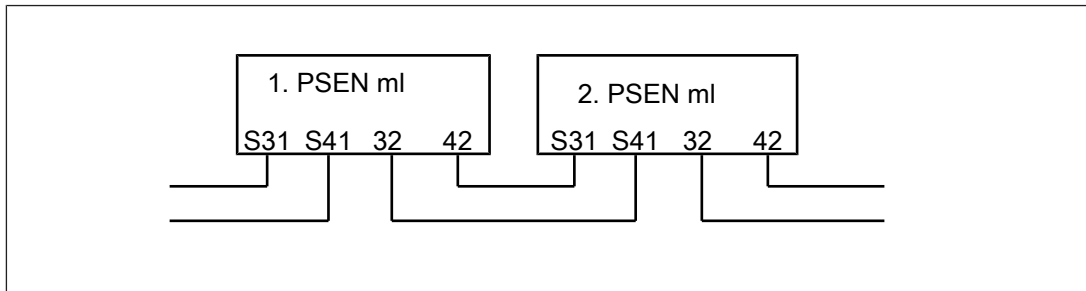

4.2.1 Activation with specification of direction

- ▶ The guard locking is activated when the time between the rising edges from S31 to S41 is between 40 ms and 500 ms (S31 before S41).
- ▶ The guard locking is deactivated when the time between the rising edges from S31 to S41 is between 40 ms and 500 ms (S41 before S31).

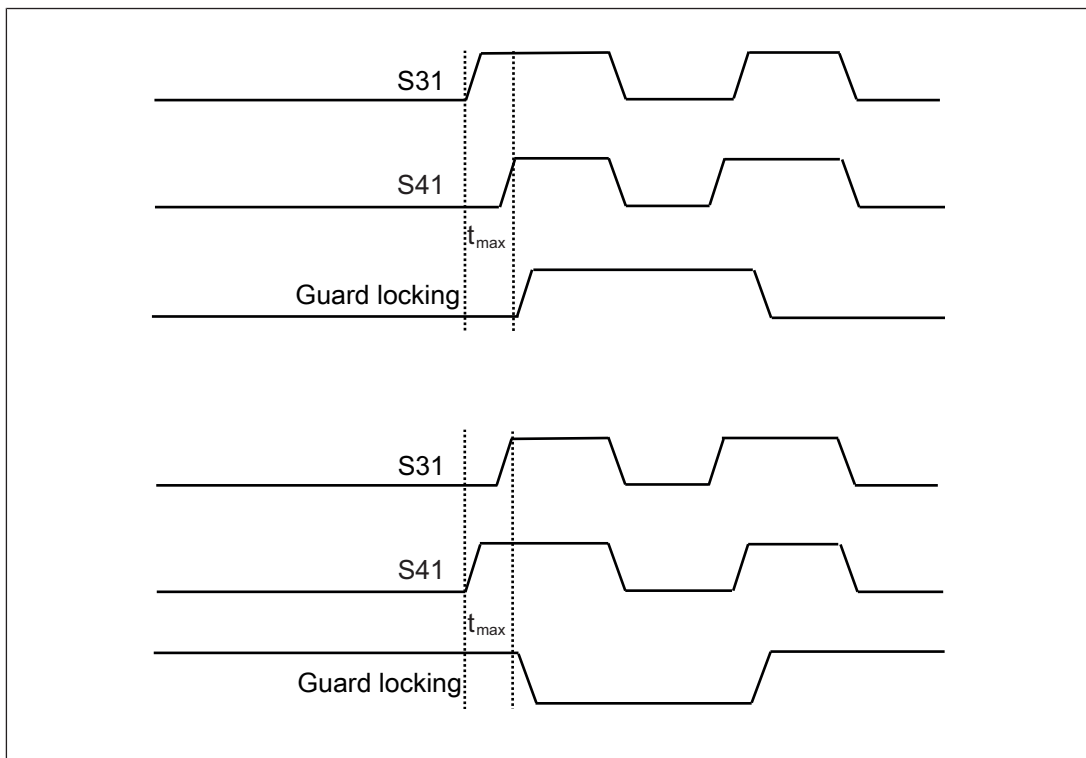

Legend

t_{\max} Maximum time between the rising edges from S31 and S42

4.2.2 Activation without specification of direction

- ▶ The guard locking changes its state when the time between the rising edges from S31 and S41 < 20 ms.

4.3 Safety Device Diagnostics

Safety Device Diagnostics is an option that can be selected independently of the safety-related wiring.

When using the Safety Device Diagnostics, up to 16 sensors connected in series can be connected as a subscriber to a fieldbus module.

The communication of the sensors with the fieldbus module is automatically built up again with **each** new supply of the supply voltage. As a result, a sensor can be exchanged, e.g. when servicing, without the need for special measures.

An exchange can be detected via the fieldbus module e.g. through the serial number.

- ▶ With Safety Device Diagnostics there are the following diagnostic options for the fieldbus module:
 - Poll information of the sensors (examples: what sensor in the series has switched, at what point could there be an open circuit in the series connection)
 - Read configuration parameters of the sensor (examples: Number of teach-in processes remaining, serial number of the switch)
 - Perform actions (example: poll updated actuator name)
 - Selectively activate or deactivate guard locking of individual PSEN ml within a series connection

The results of the sensor diagnostics can be checked already during the installation phase via the display in the fieldbus module, without the need to connect the fieldbus module to the network.

- ▶ With Safety Device Diagnostics there are the following diagnostic options for the fieldbus module for simple wiring:
 - Information is passed on via the fieldbus module directly to the network
 - Mappings of the signal outputs to the sensor are automated by the SDD.This prevents wiring errors and an expansion or reduction of the sensors is possible without the need to change existing wiring.
 - Wiring in accordance with IP20: Rapid installation in the control cabinet is enabled.
 - Wiring in accordance with IP67: Various passive junctions can be used (see [Order references for accessories](#)  71) to connect several sensors with only one cable from the field in the control cabinet.

Further information on Safety Device Diagnostics can be found in [Additional documents that apply](#)  8].

4.4 Operating modes

The safety switch can be used in various operating modes.

- ▶ Operation without safety device diagnostics
 - Standard operating mode
After every restart the safety switch is in operation without Safety Device Diagnostics.
 - No communication with Safety Device Diagnostics

- Activating/deactivating the guard locking is only via the signals S31 and S41
- ▶ Operation with passive use of the Safety Device Diagnostics
 - Safety switch supplies diagnostic data to Safety Device Diagnostics
 - Activating/deactivating the guard locking is only via the signals S31 and S41
- ▶ Operation with active use of the Safety Device Diagnostics
 - Activate/deactivate the guard locking by a combination of a Safety Device Diagnostics command and the status of the safety inputs S31 and S41 (S31 and S41 must have a high signal).

The safety requirements are guaranteed by the signals S31 and S41 (the fieldbus for Safety Device Diagnostics communication is not safe).
- ▶ Operation with specification of direction when activating/deactivating the guard locking
 - A specification of direction can be used to control the change of the guard locking status.
 - Toggling: The safety switch changes with each simultaneous controlling of S31 and S41 the guard locking status (activated <-> deactivated).
 - Force Direction: The safety switch is selectively activated or deactivated by offset activation of the rising edges of S31 and S41.

Timing diagrams

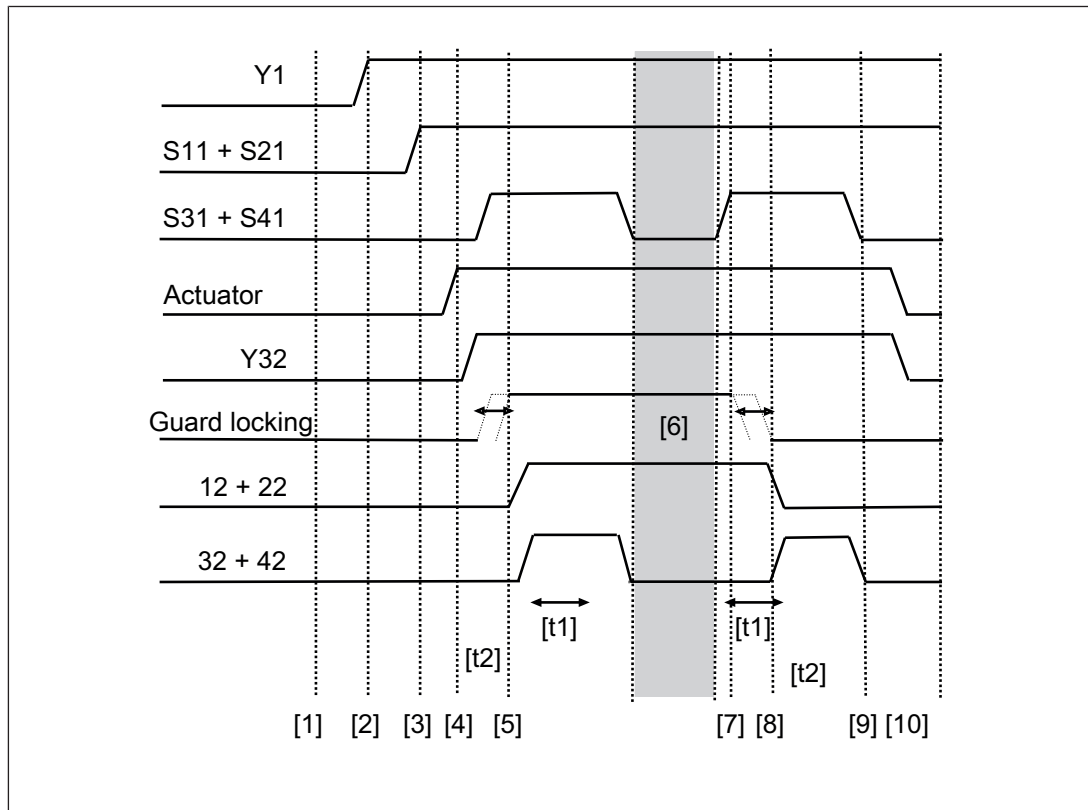

Fig.: Passive use of the Safety Device Diagnostics

Legend

- [1] Gate is open
- [2] The door connected upstream in the series connection is closed
- [3] The door connected upstream in the series connection is locked
- [4] Gate is closed
- [5] Guard locking is activated by the programmable safety system
- [6] Guard locking is activated
- [7] Execution of the hazardous machine function is permitted
- [8] Outputs will be deactivated
- [9] Guard locking will be deactivated
- [10] Gate is open
- [t1] Processing time of guard locking signal = 100 ms
- [t2] Time window for changing guard locking status

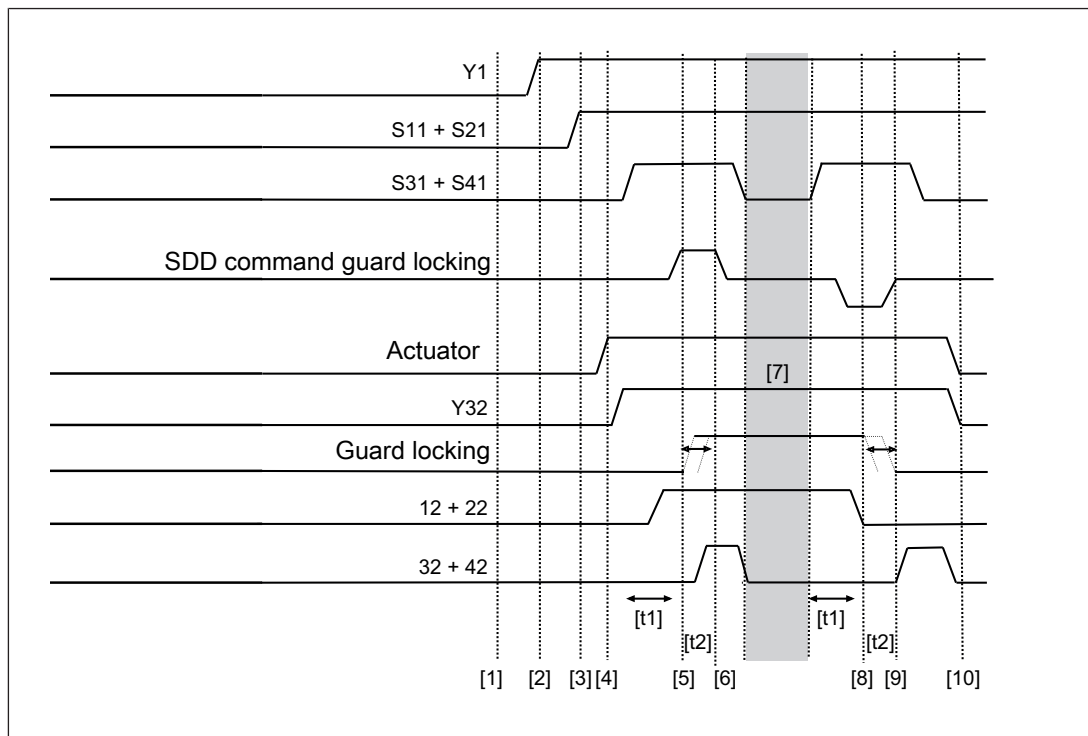
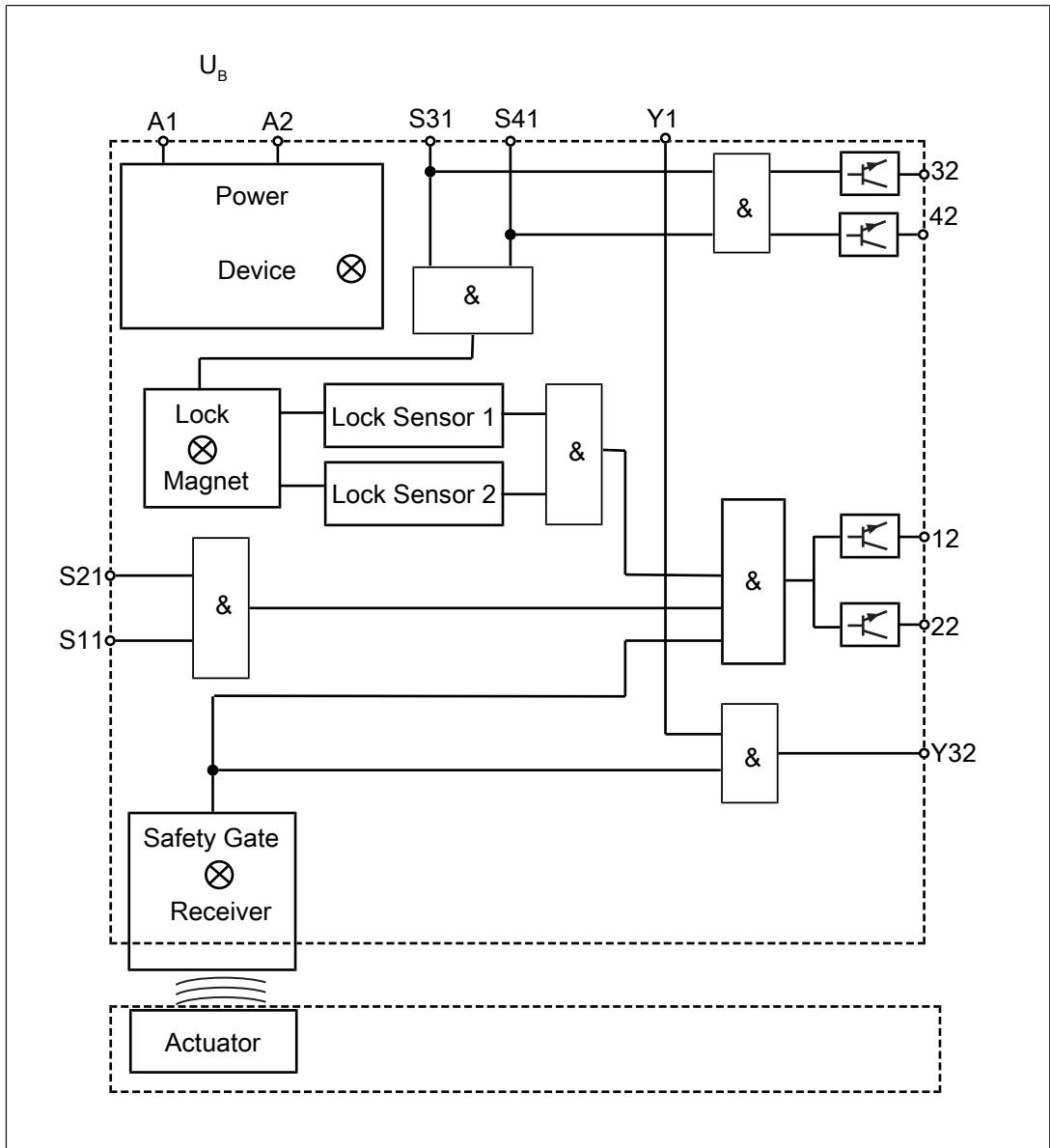

Fig.: Active use of Safety Device Diagnostics

Legend

- [1] Gate is open
- [2] The door connected upstream in the series connection is closed
- [3] The door connected upstream in the series connection is locked
- [4] Gate is closed
- [5] Guard locking is activated by the programmable safety system
- [6] Guard locking is activated
- [7] Execution of the hazardous machine function is permitted
- [8] Outputs will be deactivated
- [9] Guard locking will be deactivated
- [10] Gate is open
- [t1] Processing time of guard locking signal = 100 ms
- [t2] Time window for changing guard locking status

4.5 Block diagram



4.6 Auxiliary release

The auxiliary release enables guard locking to be opened from the access side to the danger zone.

The safety switch has auxiliary releases on three sides.

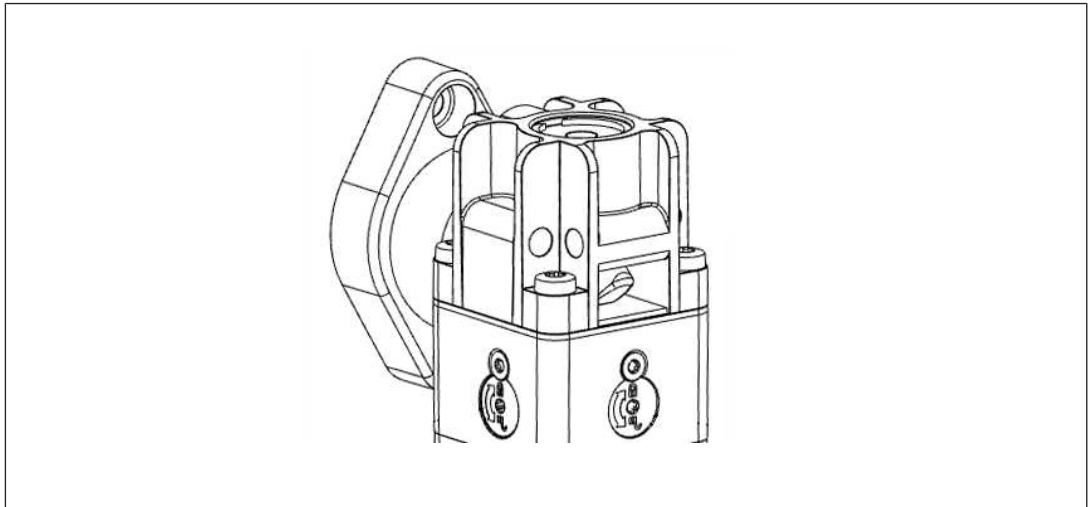

INFORMATION

If guard locking is deactivated using the auxiliary release, there is a low signal at safety outputs 12 and 22. An error code will be issued (see under Operation) and the safety switch switches to a fault condition.

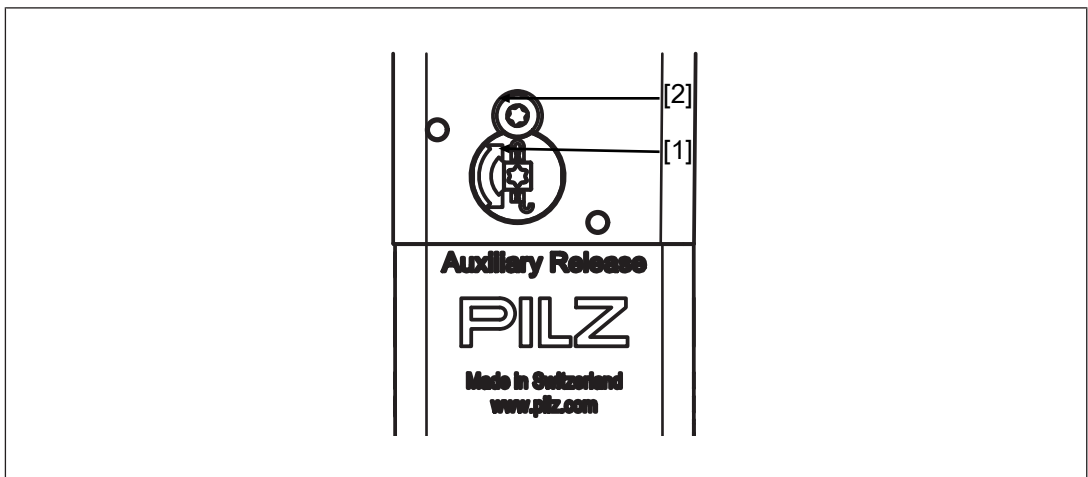

Legend

- [1] Auxiliary release screw Torx T10
- [2] Security screw Torx T10, sealed with varnish when delivered

Mode of operation:

1. Remove the security screw [2] using a Torx T10 screwdriver.
2. Rotate the auxiliary release screw [1] half a turn anti-clockwise using a Torx T10 screwdriver. The guard locking pin is displaced and the bolt is released.

The safety gate to the danger zone can be opened.

4.6.1 Recommissioning

Recommission PSEN ml s 1.1

1. Rotate the auxiliary release screw [1] (see [Figure \[20\]](#)) half a turn clockwise using a Torx T10 screwdriver.
2. Re-insert the security screw [2] (see [Figure \[20\]](#)) using a Torx T10 screwdriver.
3. Seal the security screw with varnish.
4. Switch the voltage off and then on again.
5. Carry out a function test on the safety switch and actuator. The safety function may only be checked by qualified personnel.



INFORMATION

If the auxiliary release screw is not turned back correctly after use, the PSEN ml s 1.1 switches to a fault condition.

4.7 Prevent restart

To prevent the machine restarting (unintentionally) while there is someone inside the danger zone, a padlock can be attached via the through hole on the actuator (see diagram). As a result the actuator cannot engage with the safety switch, guard locking is not activated and the machine is prevented from starting.

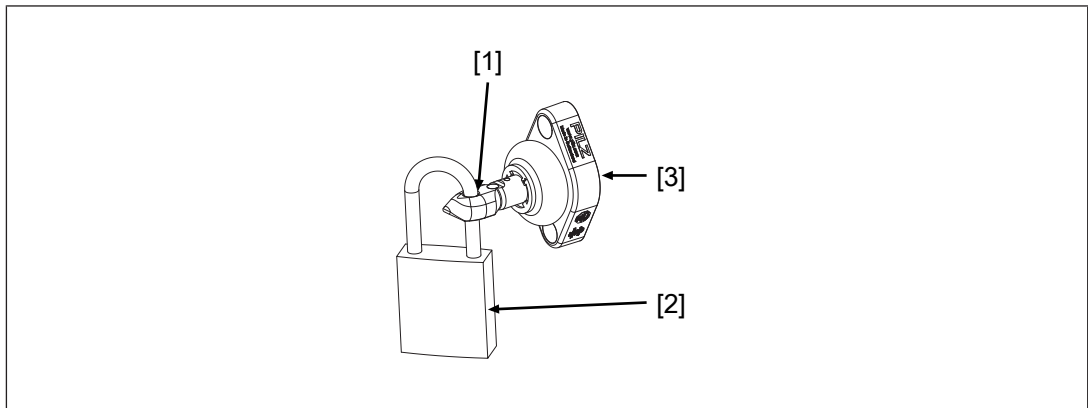

Legend

- [1] Through hole on the actuator for attaching a padlock
- [2] Padlock
- [3] Actuator

If the actuator is to be blocked using several locks in parallel, a multiple lock can be used (e.g. Brady – Lockout device, article no. 852439).

4.8 Escape release

Distinction between escape release and emergency release

- ▶ The emergency release enables the manual release of the guard locking without aids from outside the hazardous area.
- ▶ The emergency release enables the manual release of the guard locking without aids from within the hazardous area and it corresponds to an escape release in accordance with **EN ISO 14119**.

If the escape release accessory (stationary or external) is installed **within** the hazardous area, the accessory can be used as an escape release in accordance with EN ISO 14119.

If the escape release accessory (stationary or external) is installed **outside** the hazardous area, the accessory can be used as an escape release in accordance with EN ISO 14119.

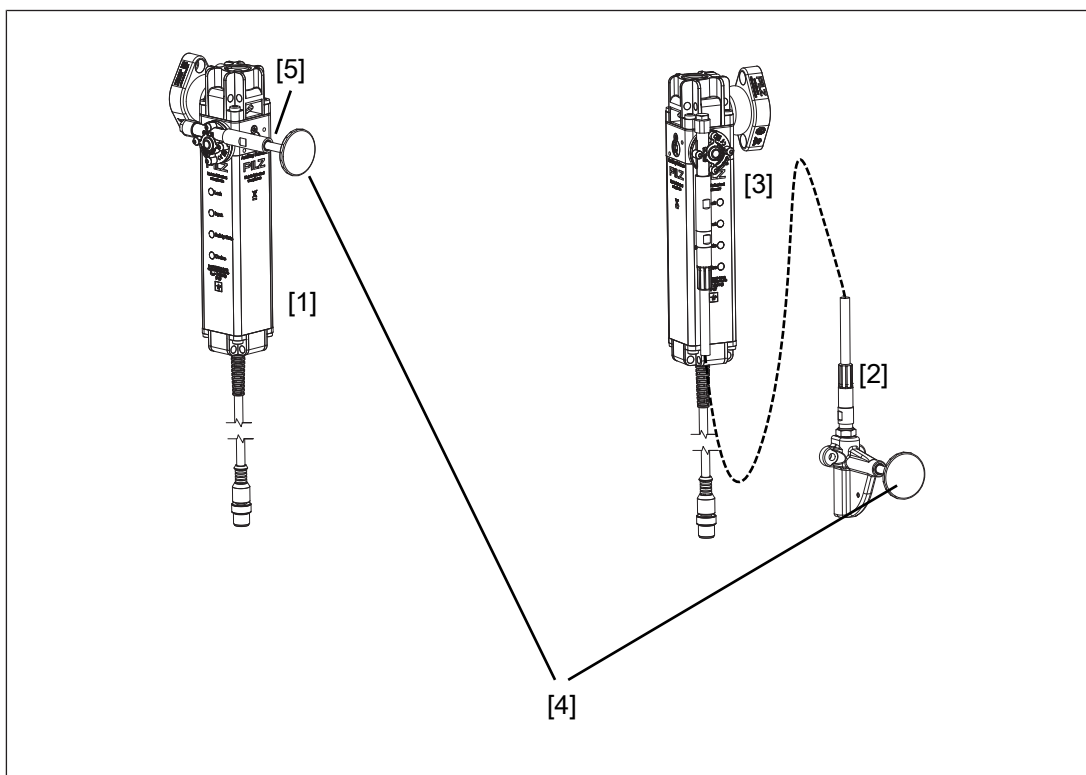

Legend

- [1] Escape release stationary
- [2] Escape release externally
- [3] Tension pressure cables in lengths of 1.50 m to 4 m
- [4] Button of the escape release pin
- [5] Escape release pin



INFORMATION

If guard locking is deactivated using the auxiliary release, there is a low signal at safety outputs 12 and 22. An error code will be issued (see under Operation) and the safety switch switches to a fault condition.

Mode of operation

If in the hazardous area the button of the escape release pin [4] is pressed towards the safety gate, the escape release impacts directly on the auxiliary release of the safety switch and the auxiliary release unlocks the safety gate. The safety gate can be opened immediately, enabling the operator to leave the danger zone.

There is a low signal at safety outputs 12 and 22 if the escape release was operated.

Scope

- ▶ Scope of supply stationary escape release
 - 1 escape release stationary
 - 1 adapter disk
 - 2 screws for adapter disk
 - 4 screws for installation on the adapter disk
- ▶ Scope of supply external escape release
 - 1 escape release external with installed push/pull cables (see [Order reference: Accessories \[71\]](#))
 - 1 adapter disk
 - 2 screws for adapter disk
 - 4 screws for installation on the adapter disk

4.8.1**Recommissioning**

1. Pull back the button of the escape release pin.
2. Switch the voltage off and then on again.
3. Carry out a function test using the escape release. The safety function may only be checked by qualified personnel.

5 Wiring

5.1 Important information

- ▶ Hand-tighten the connector.
- ▶ Information given in the [Technical details](#) [ 65] must be followed.

5.2 Pin assignment, connector and cable

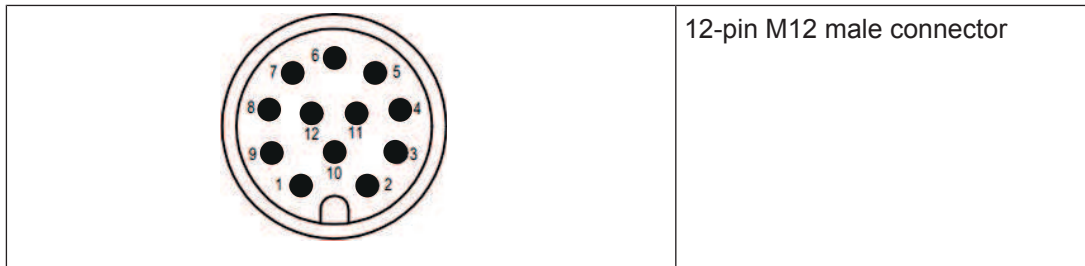

PIN	Function	Terminal designation	Cable colour (Pilz cable)
1	+24 V UB	A1	Brown
2	0 V UB	A2	Blue
3	Operation of solenoid to open and close guard locking (channel 2)	S41	White
4	Safety output channel 1	12	Green
5	Operation of solenoid to open and close guard locking (channel 1)	S31	Pink
6	Safety output channel 2	22	Yellow
7	Safety input channel 1	S11	Black
8	Signal output/diagnostic output	Y32	Grey
9	Diagnostics input	Y1	Red
10	Safety input channel 2	S21	Purple
11	Operation of solenoid of the next safety switch in the series connection (channel 1)	32	Grey-pink
12	Operation of solenoid of the next safety switch in the series connection (channel 2)	42	Red-blue

**NOTICE**

The colour marking for the connection lead only applies for the cable that Pilz supplies as an accessory

5.3**EMC requirements**

- ▶ Ensure the wiring and EMC requirements of EN 60204-1 are met.
- ▶ UL requirement: The supply voltage to the safety switch must be protected with a quick-acting fuse (see [Technical details \[65\]](#)).
- ▶ The inputs and outputs of the safety switch must have a protective separation to voltages over 60 V AC.
- ▶ The power supply must meet the regulations for extra low voltages with protective separation (SELV, PELV) in accordance with EN 60204-1.

**INFORMATION**

Only use safety relays with a 24 VDC supply voltage. Safety relays with a wide-range power supply or in AC device versions have internal potential isolation and are not suitable as evaluation devices.

6 Connection to control systems and evaluation devices

6.1 Important information

Make sure that the selected evaluation device has the following properties:

- ▶ 2-channel with feasibility monitoring
Both OSSDs must change switch state synchronously. In particular, the evaluation device must monitor that the state of **both** OSSDs was "Gate unlocked" before **both** return to the "Gate locked" state and vice-versa.
- ▶ OSSD signals are evaluated through 2 channels
- ▶ The state of the OSSDs must be tested before and after safety inputs S31 and S41 are activated (solenoid operation) (see [Timing diagram](#) [ 17])



WARNING!

Potential loss of safety function due to failure to test for a safe condition

Depending on the application, serious injury or death may result.

- Use an evaluation device/safety system to test whether the plant is in a safe condition.
- Do not operate the solenoid of the PSEN ml s 1.1 via S31/S41 unless the plant is in a safe condition.

- ▶ The use of Safety Device Diagnostics is described in the System Description "Safety Device Diagnostics".

6.2 Minimum requirements for activation of guard locking

Use in PL e (Cat. 4) applications

- ▶ Safety inputs S31 and S41 (solenoid operation) have 2-channel operation via safe outputs, which are suitable for PL e (Cat. 4) applications
- ▶ 2-channel operation for safety inputs S31 and S41 (solenoid operation), each with 0.5 A
- ▶ 2-channel processing of safety outputs
- ▶ Monitoring of shorts across signal cables through activation of guard locking

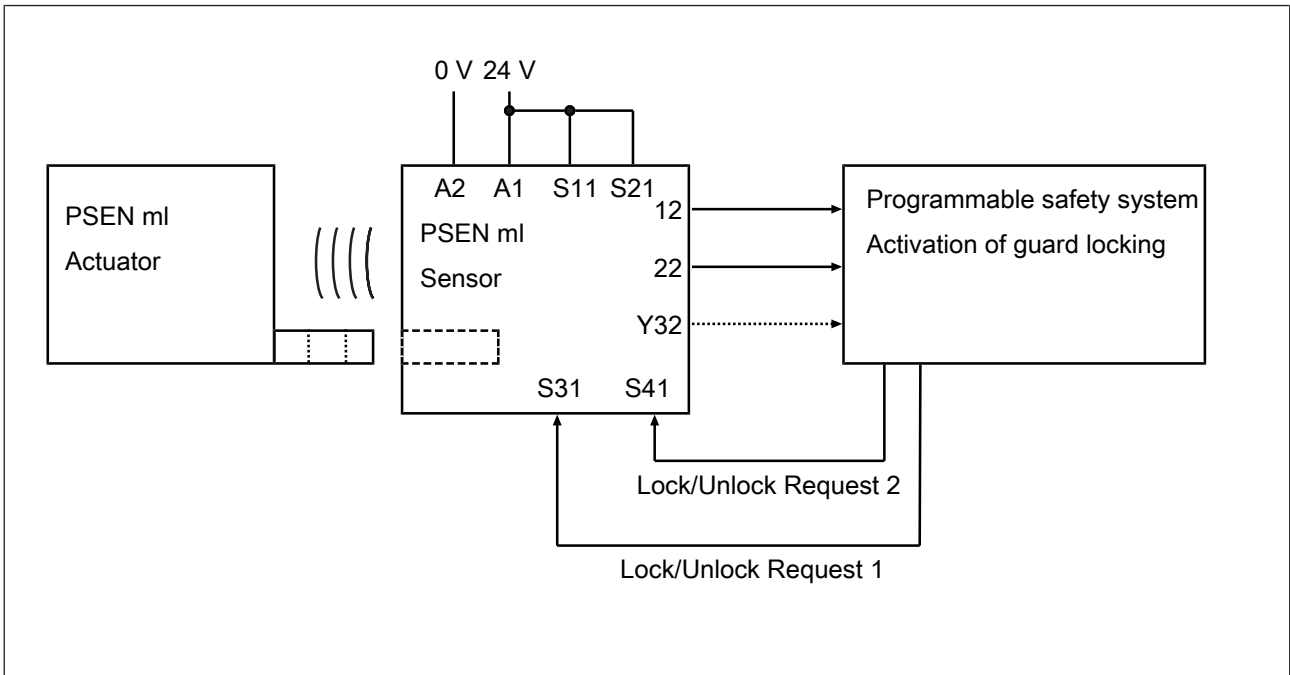

Use in PL d (Cat. 3) applications

- ▶ 2-channel operation for safety inputs S31 and S41 (solenoid operation) via relay outputs
- ▶ 2-channel operation for safety inputs S31 and S41 (solenoid operation), each with 0.5 A
- ▶ 2-channel processing of safety outputs
- ▶ Exclusion of shorts across signal cables through appropriate measures (e.g. protected cable layout, see EN ISO 13849-2)

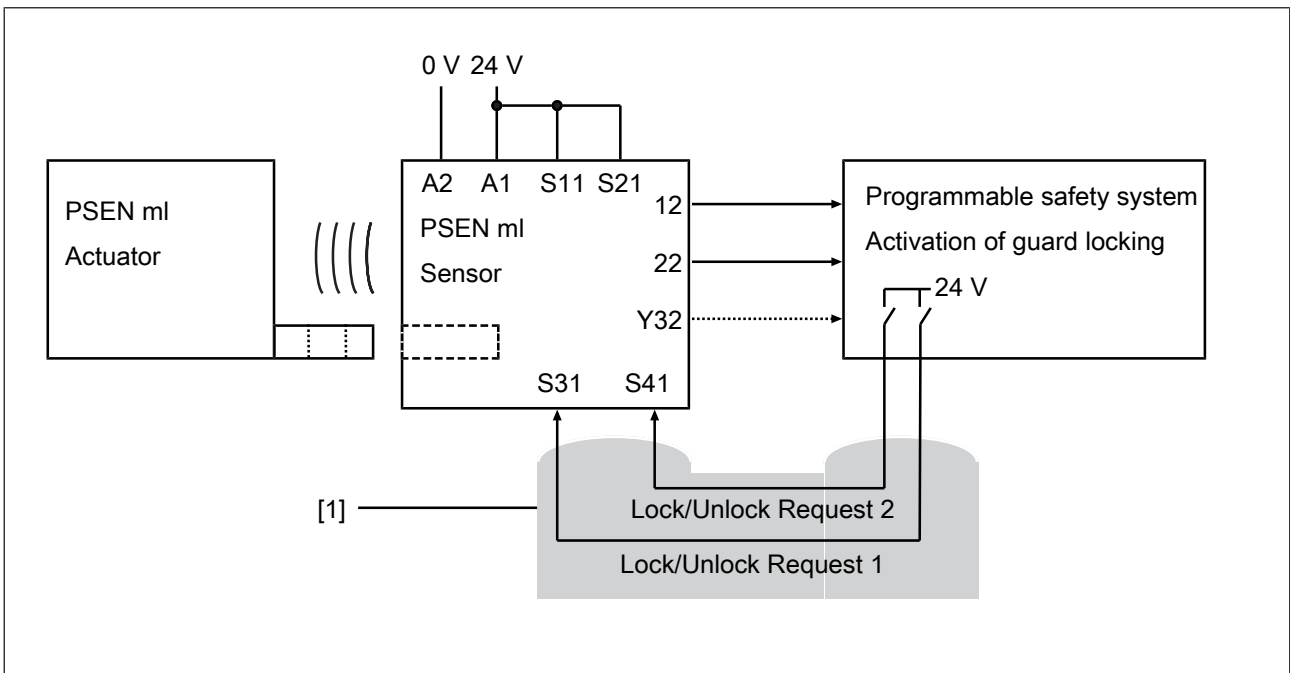

Legend

[1] Protected cable layout

Use in PL d (Cat. 2) applications

- ▶ 1-channel operation for safety inputs S31 and S41 (solenoid operation)
- ▶ 2-channel processing of safety outputs
- ▶ 1-channel operation for interconnected safety inputs S31 and S41 (solenoid operation), with 1 A

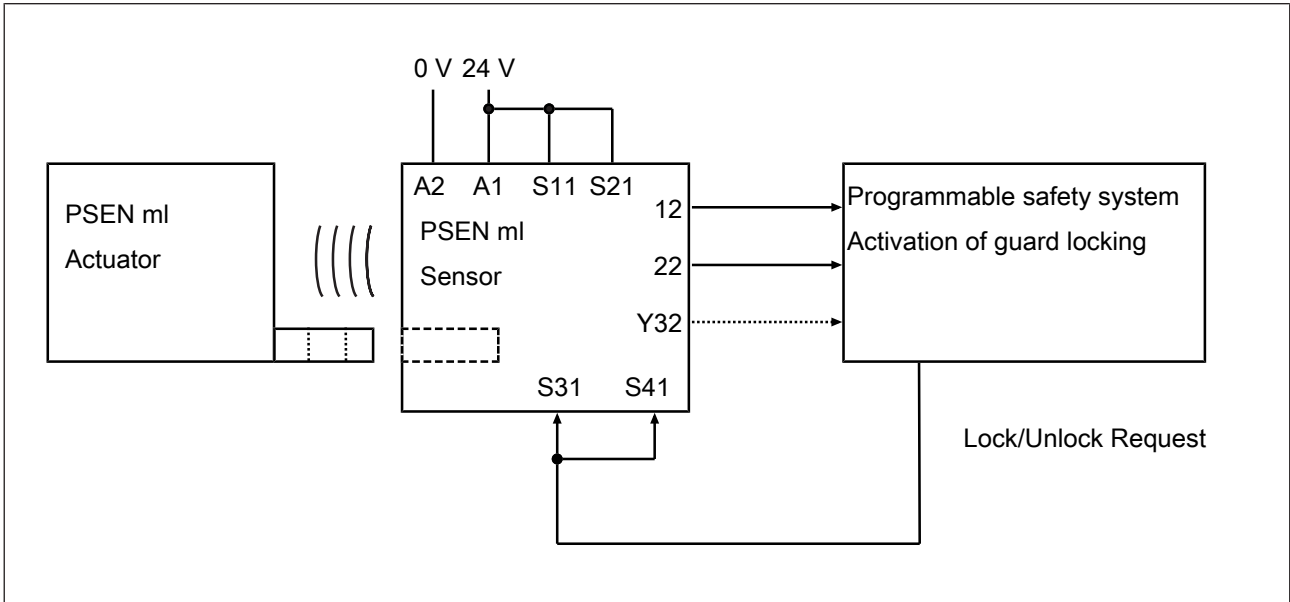

6.3 Single connection

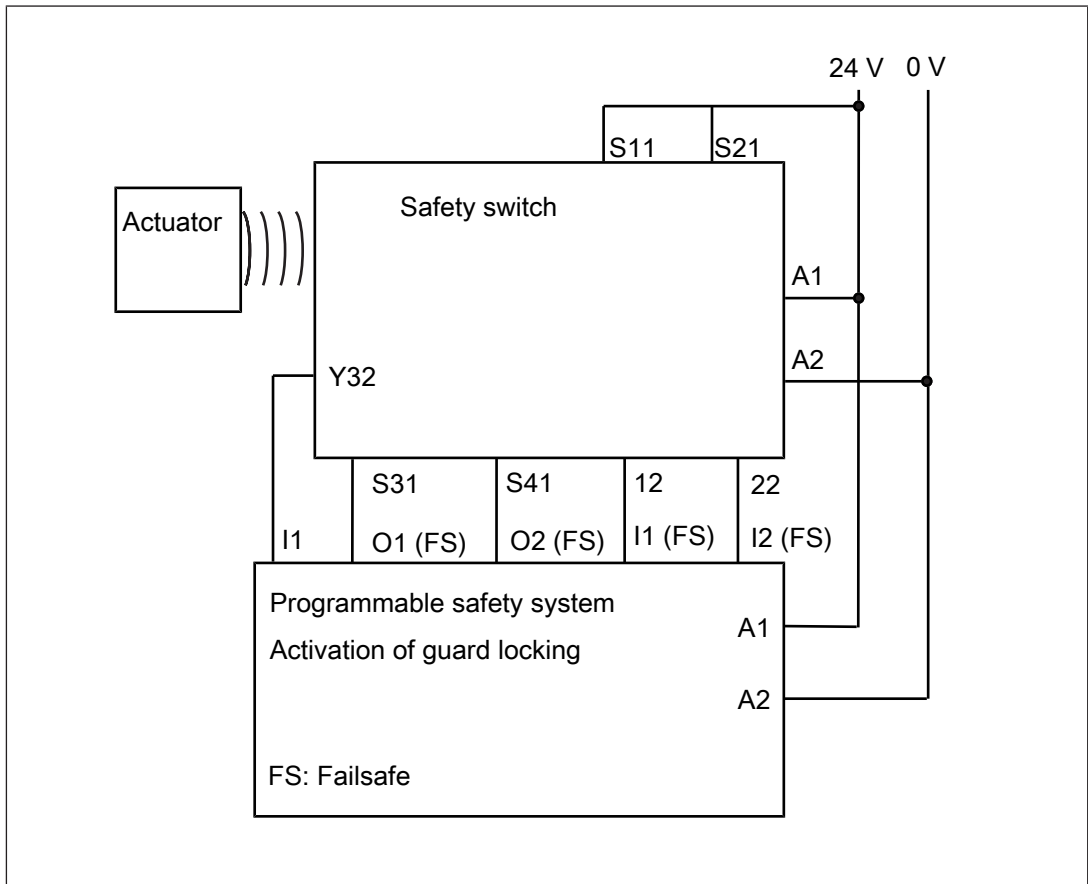

6.4 Series connection



CAUTION!

Extension of delay-on de-energisation

When several (n) devices are connected in series, the delay-on de-energisation time adds with the number of interconnected safety switches.

The max. delay-on de-energisation is made up of the

risk time (see [Technical details](#) [65])

+ (n-1) x max. delay-on de-energisation of the inputs

+ max. delay-on de-energisation of the evaluation device

The safety switches PSEN ml s 1.1 are suitable for series connection with max. 16 safety switches.

In practice, the maximum possible number will be limited by the following parameters, among others:

- ▶ The required SIL level (e.g. SIL CL 3),
- ▶ the required performance level (e.g. PL e (Cat. 4)),
- ▶ the maximum delay or risk time permitted by the application,
- ▶ Cable length (see notes on cable lengths),
- ▶ Height of supply voltage.

Ensure there is sufficient supply voltage, taking inrush currents and fusing into consideration.

Notes on cable lengths

- ▶ Determine the values under the following conditions:

Room temperature (25°C), conductor cross section 0.25 mm², output load per output (12, 22, Y32) each ≤ 10mA

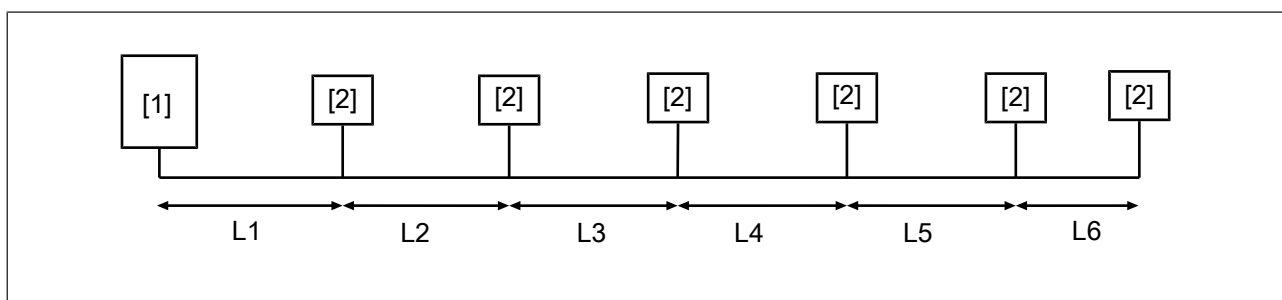

Legend

[1] Safety control system

[2] Safety switch PSEN ml

Examples for cable lengths

- ▶ Operating voltage at the safety control system ≥ 20.4 V

Number of safety switches	L1	L2	L3	L4	L5	L6	Overall length
1	50 m						50 m
2	30 m	20 m					50 m
3	20 m	10 m	10 m				40 m
4	20 m	5 m	5 m	5 m			35 m
5	10 m	5 m	5 m	5 m	5 m		30 m
6	5 m	5 m	5 m	5 m	5 m	5 m	30 m

- ▶ Operating voltage at the safety control system ≥ 24 V

Number of safety switches	L1	L2	L3	L4	L5	L6	Overall length
1	120 m						120 m
2	60 m	60 m					120 m
3	50 m	50 m	20 m				120 m
4	50 m	30 m	20 m	20 m			120 m
5	50 m	20 m	20 m	20 m	10 m		120 m
6	20 m	20 m	20 m	20 m	20 m	20 m	120 m

- ▶ Operating voltage at the safety control system ≥ 28.8 V

Number of safety switches	L1	L2	L3	L4	L5	L6	Overall length
1	180 m						180 m
2	130 m	50 m					180 m
3	80 m	50 m	50 m				180 m
4	50 m	50 m	50 m	30 m			180 m
5	50 m	50 m	30 m	30 m	20 m		180 m
6	50 m	50 m	20 m	20 m	20 m	20 m	180 m

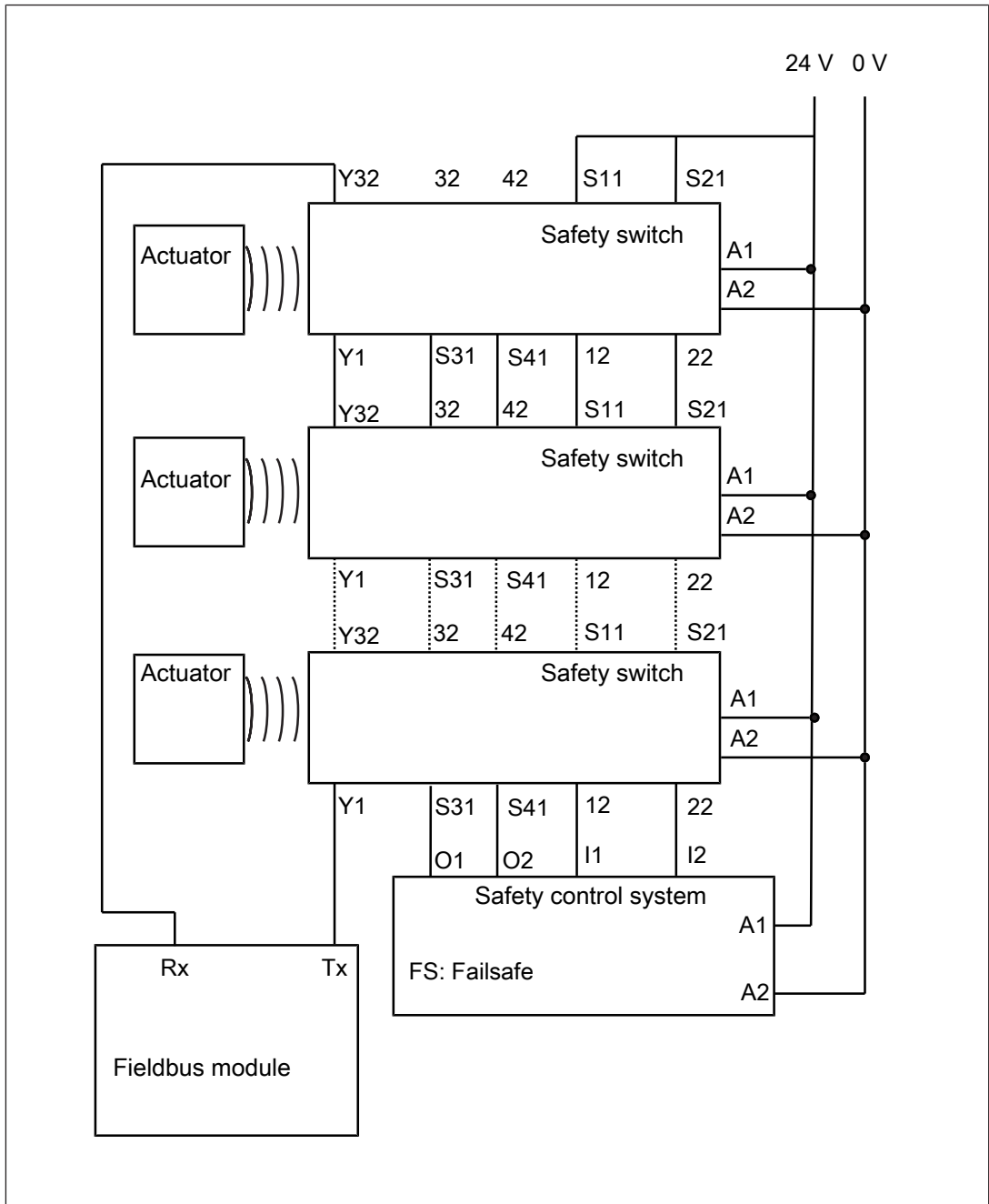

For connecting the safety switch PSEN ml s 1.1 in a series connection there are the following options:

- ▶ Wiring with the safety control system via PSEN ml Y junction

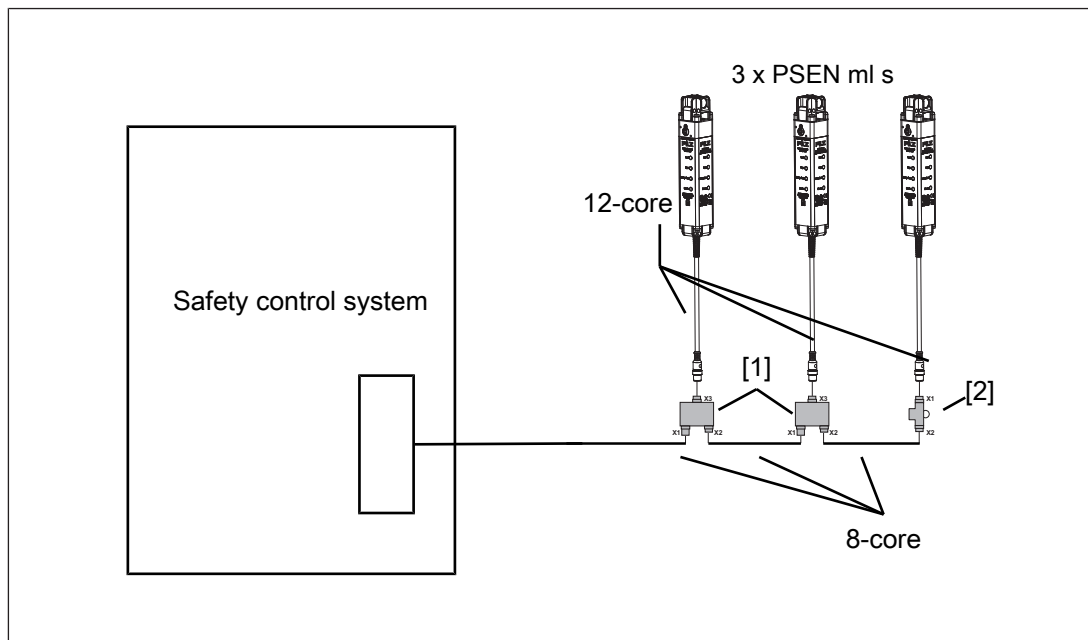

Legend

[1] PSEN ml Y junction M12

[2] PSEN ml end adapter

- ▶ When establishing the series connections with connection to the safety control system, use the following adapters:
 - PSEN ml Y junction M12
 - PSEN ml end adapter
- ▶ Connection in the control cabinet at the terminal block
 - Connect the 12-core cables of the safety switch to the terminal block of the control cabinet.

6.5 Connection to Pilz evaluation devices

The safety switch PSEN ml s 1.1 can be connected to Pilz evaluation devices, for example.

Suitable Pilz evaluation devices are, for example:

- ▶ PNOZmulti for safety gate monitoring
Configure the switch in the PNOZmulti Configurator with switch type 3.
- ▶ PSS for safety gate monitoring with standard function block SB064, SB066 or FS_Safety Gate
- ▶ PSSuniversal PLC for safety gate monitoring with function block FS_SafetyGate

The correct connection to the respective evaluation device is described in the operating manual for the evaluation device. Make sure that the connection is made in accordance with the specifications in the operating manual for the selected evaluation device.

Connection to PNOZmulti is illustrated by way of example.

6.5.1 Connection example with PNOZmulti and Safety Device Diagnostics

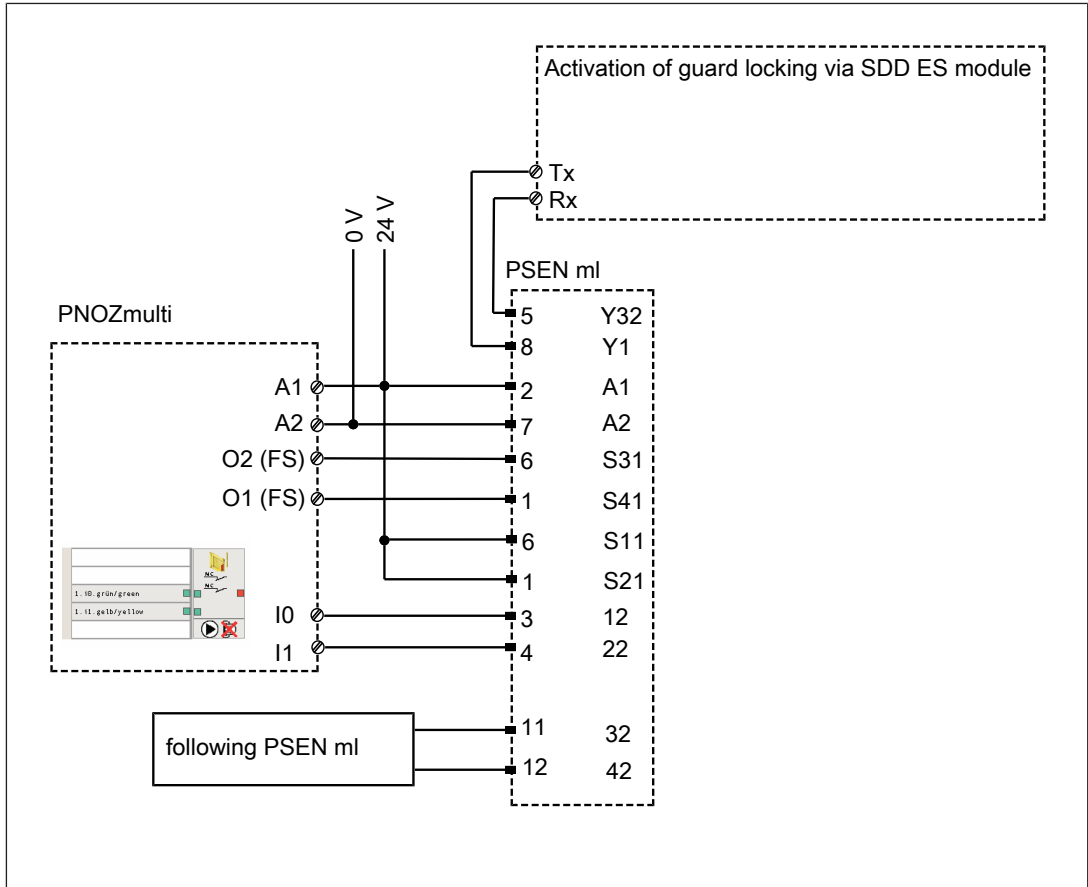

7 Teaching in the actuator

7.1 PSEN ml 1.1

Any corresponding Pilz actuator (see [Technical Details \[65\]](#)) is detected as soon as it is brought into the response range.

8 Installation

8.1 Important information



INFORMATION

Refer to the guidelines for designing guards and integrating interlocks with guard locking in EN ISO 14120.





NOTICE

Install the safety switch and actuator so that the possibilities of defeat are reduced to a minimum (see guidelines for reducing the possibilities for defeating interlocking devices in EN ISO 14119).



NOTICE

Install safety switch and actuator so that it is not possible to reach through with hand or finger.

- ▶ The safety switch and actuator should be installed opposite each other in parallel.
- ▶ Make sure that the actuator makes complete contact with the mounting surface.
- ▶ Make sure that at least one of the auxiliary release/escape releases can be operated after installation.
- ▶ For a minimum screw depth of 6 mm, M5 screws with resistance class 8.8 should be used to attach the safety switch and actuator.
- ▶ Torque setting: Please note the information provided under [Technical details](#)  65].
- ▶ Use non-removable flat head locking screws to attach the safety switch and actuator (e.g. cheese-head or pan head screws) or rivets.
- ▶ Use the same type of screw to attach the safety switch and actuator.
- ▶ Installation of the safety switch and actuator must be concealed.
- ▶ Prevent self-loosening of the fastening elements on the safety switch and actuator,
 - On the safety switch: through torque (see [Technical details](#)  65])
 - On the actuator: through torque (see [Technical details](#)  65]) and bonded screw retention
- ▶ Make sure that the actuator does not present a risk.
- ▶ The mounting surfaces for safety switches and actuators can have a max. unevenness of 0.5 mm.
- ▶ Prevent the safety switch and actuator being exposed to heavy shock or vibration.
- ▶ The fastening of safety switch and actuator has to be sufficiently stable to ensure the proper operation of the safety switch and the actuator.

8.2 Tapped hole

- ▶ To fix the safety switch at the three possible mounting positions, there are 3 drill holes on 3 sides.

As a result, the safety switch can be installed on the frames of left and right hinged sliding gates and swing gates. If necessary use a [Mounting plate \[44\]](#) or [Mounting bracket \[44\]](#) (see [Order reference: Accessories \[71\]](#)).

Different holding forces arise, based on the installation.

- [Fixing screws in parallel to actuator \[38\]](#):
 Holding force $F_{zh} = 7.500 \text{ N}$,
 Holding force F_{1max} in accordance with EN ISO 14119 = 15.000 N
- [Fixing screws side-on to actuator \[38\]](#):
 Holding force $F_{zh} = 5.000 \text{ N}$,
 Holding force F_{1max} in accordance with EN ISO 14119 = 10.000 N



INFORMATION

Please note that the stated holding forces only apply when installed without a mounting bracket. The holding forces when installed with a mounting bracket can be found in the table "[Technical details for mounting bracket \[70\]](#)".

The tapped holes must have a depth of at least 6 mm.

Installation of safety switch	Tapped hole
Fixing screws in parallel/side-on to actuator, no mounting plate	Tapped holes for four M5 screws on the mounting surface.
Fixing screws in parallel/side-on to actuator, with mounting plate	Tapped holes for two M8 screws on the mounting surface, for attaching the mounting plate.

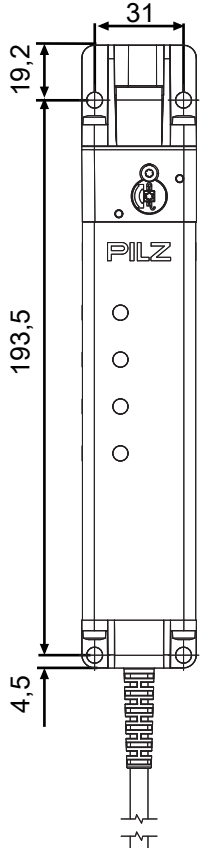
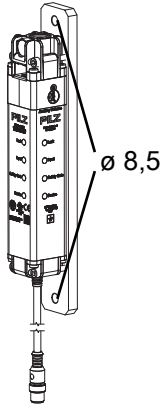
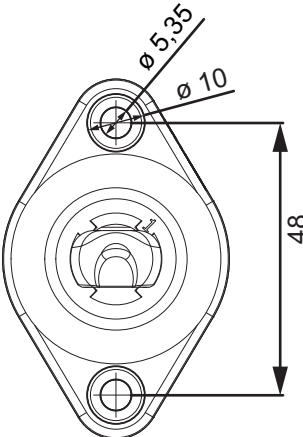
	<p>Fixing screws in parallel/side-on to actuator, no mounting plate</p> <p>Provide the mounting surface with tapped holes as indicated.</p>
	<p>Fixing screws in parallel/side-on to actuator, with mounting plate</p> <p>Provide the mounting surface with tapped holes as indicated.</p>
	<p>Actuator, no mounting bracket</p> <p>Provide the mounting surface with tapped holes for two M5 screws (see diagram).</p>

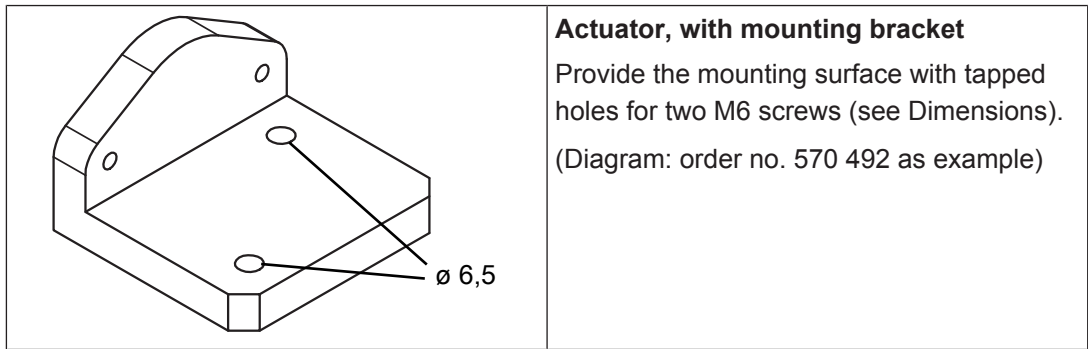

8.3 Install fixing screws in parallel to actuator

Use four M5 screws to attach the switch to the mounting surface.

► Torque setting: Please note the information provided under [Technical details](#) [65].

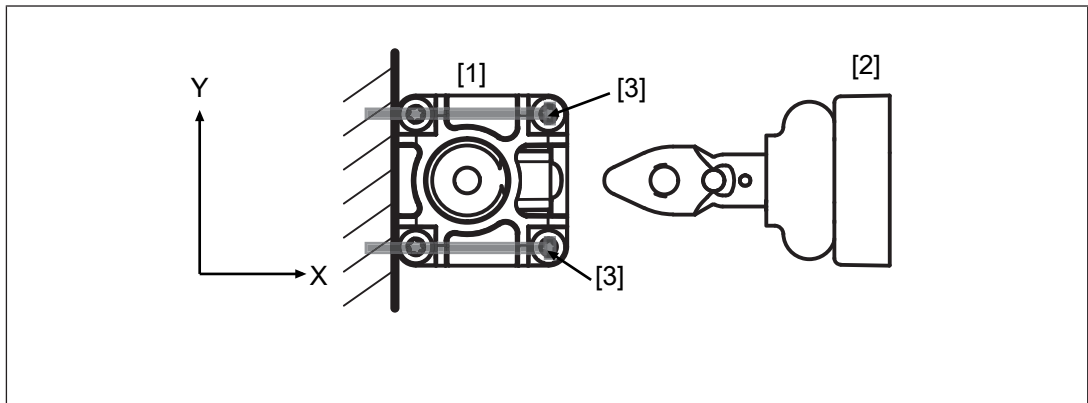
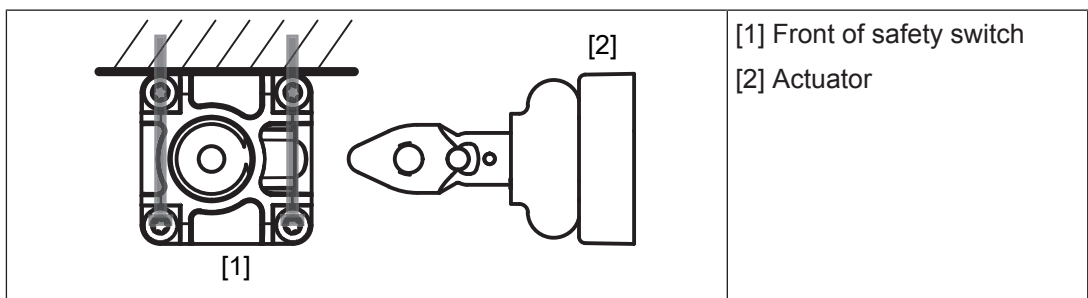

Fig.: Fixing screws of the safety switch in parallel to actuator

Legend

- [1] Safety switch
- [2] Actuator
- [3] Fixing screws of the safety switch in parallel to actuator

8.4 Install fixing screws side-on to actuator



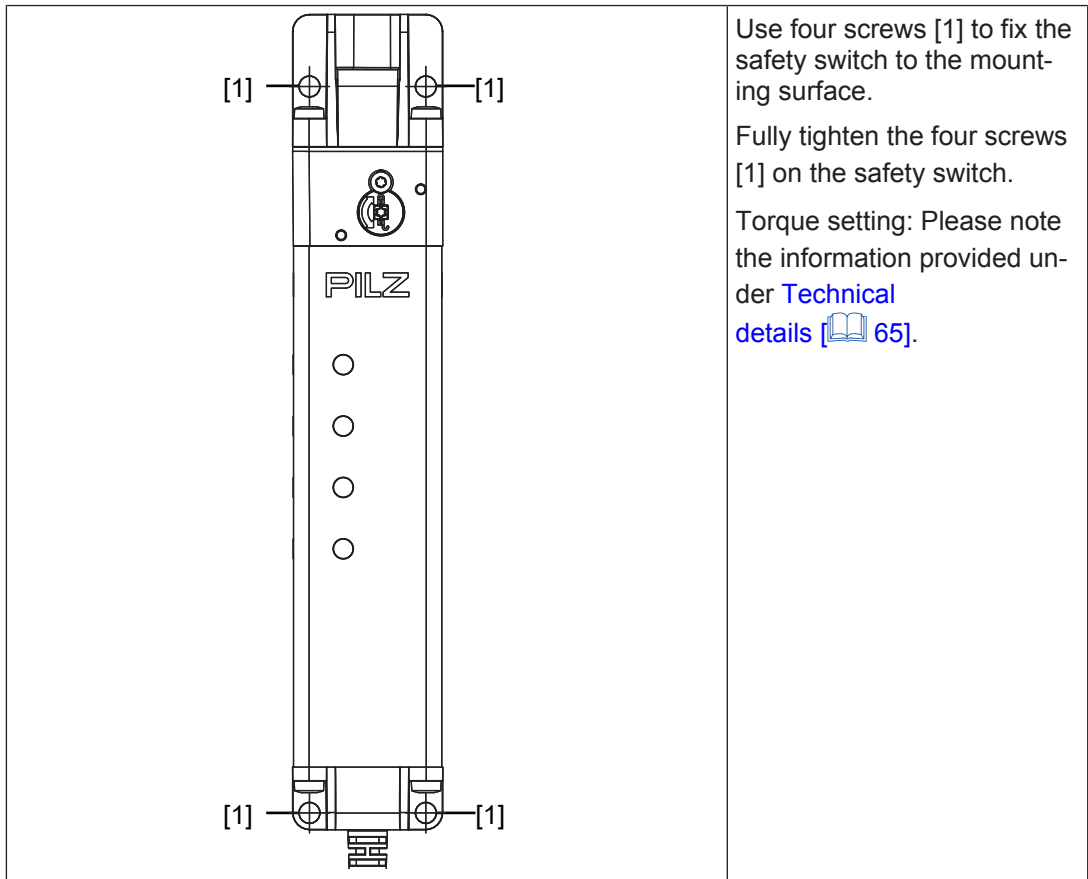

8.5 Centre the bolt in the actuator housing

The bolt must be centred in the actuator housing in order to maintain the distances on setting gates.

Centre the bolt in the actuator housing (see diagram).

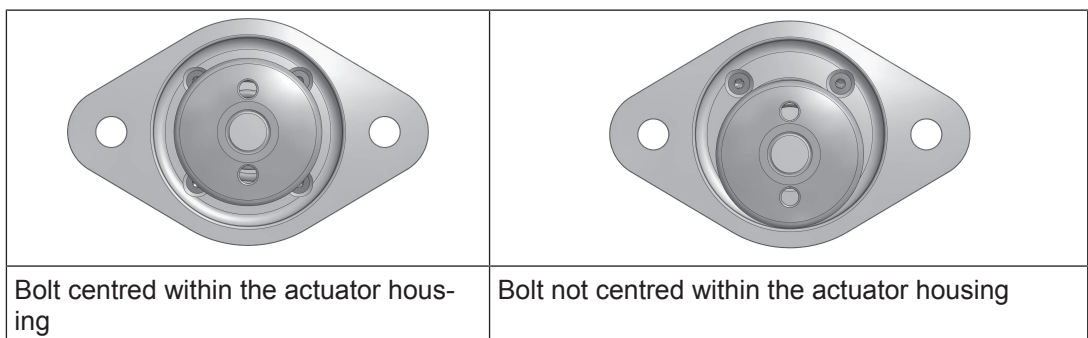

8.6 Rotate the bolt in the actuator housing 90°

The actuator can be installed vertically on a gate (see [Figure](#) [11]). To install the actuator horizontally, the bolt can be rotated 90° in the actuator housing prior to installation.

1. On the housing skin [3] in the actuator housing, press down the spring plate [1] on both sides of the bolt and keep the plate held down.
2. Rotate the bolt in the housing skin by 90° in the required direction ([2]).

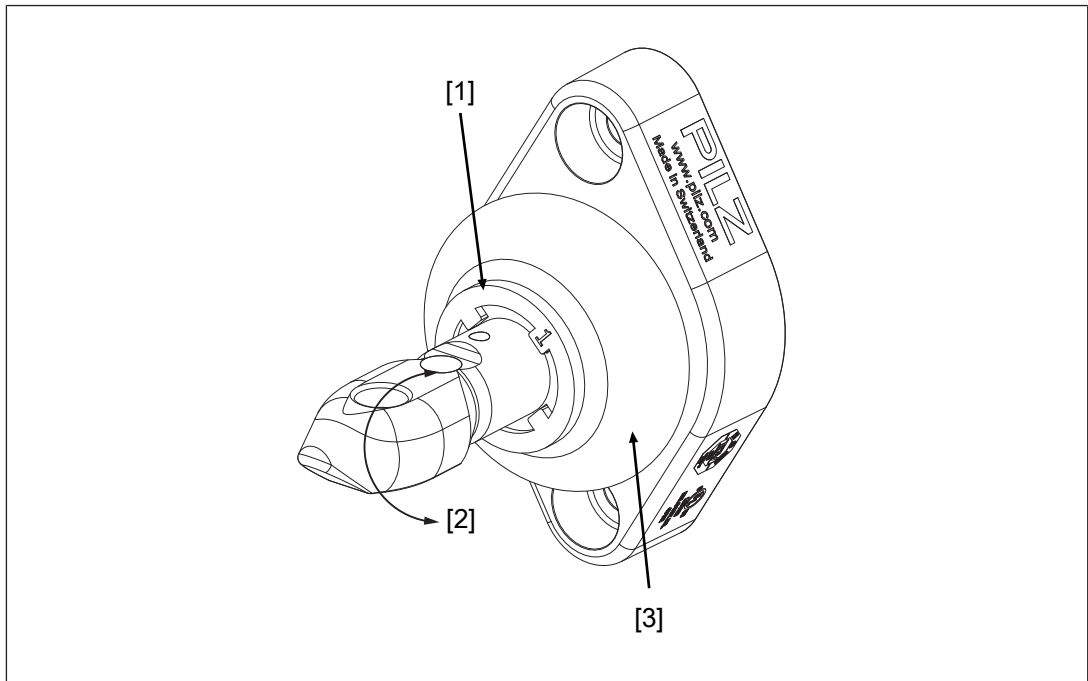
**Legend**

[1] Spring plate in the housing skin

[2] Bolt, can be rotated 90°

[3] Housing skin

3. Centre the **bolt in the actuator housing** [ 39].

8.7 Installation on sliding gate

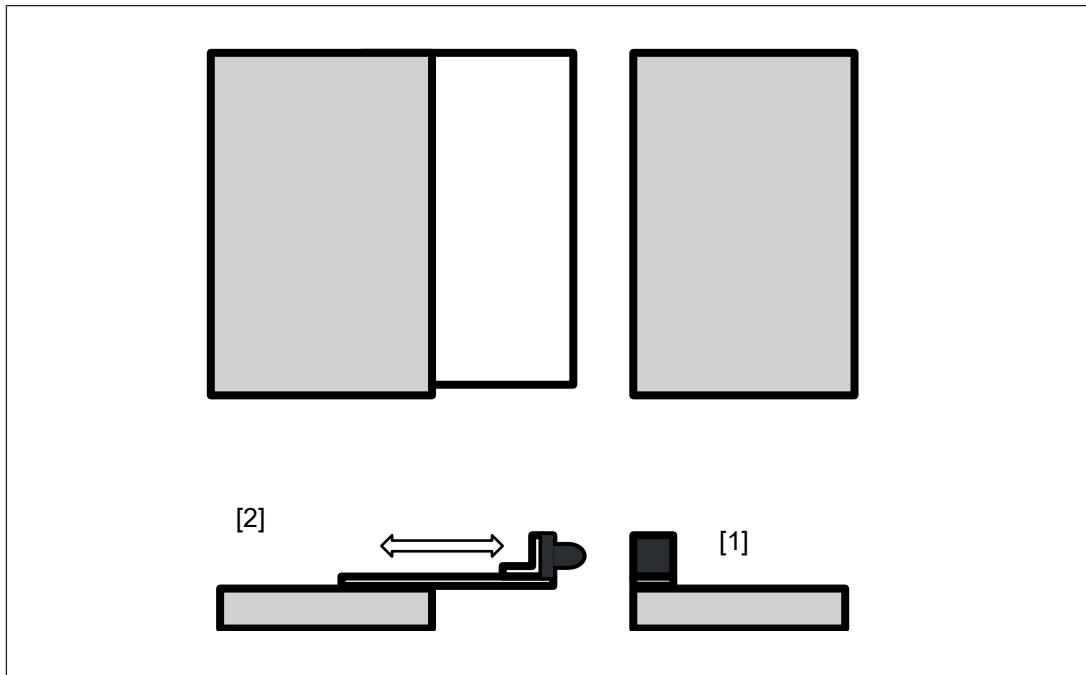

Legend

[1] Safety switch, installed on gate frame

[2] Actuator with mounting bracket (available as [Accessory \[71\]](#)), installed on sliding gate

1. Install the safety switch with the [fixing screws of the safety switch in parallel to the actuator \[38\]](#) or [side-on to actuator \[38\]](#) on the gate frame.
2. Use two M5 screws to fix the actuator to the gate.

8.8 Installation on swing gate

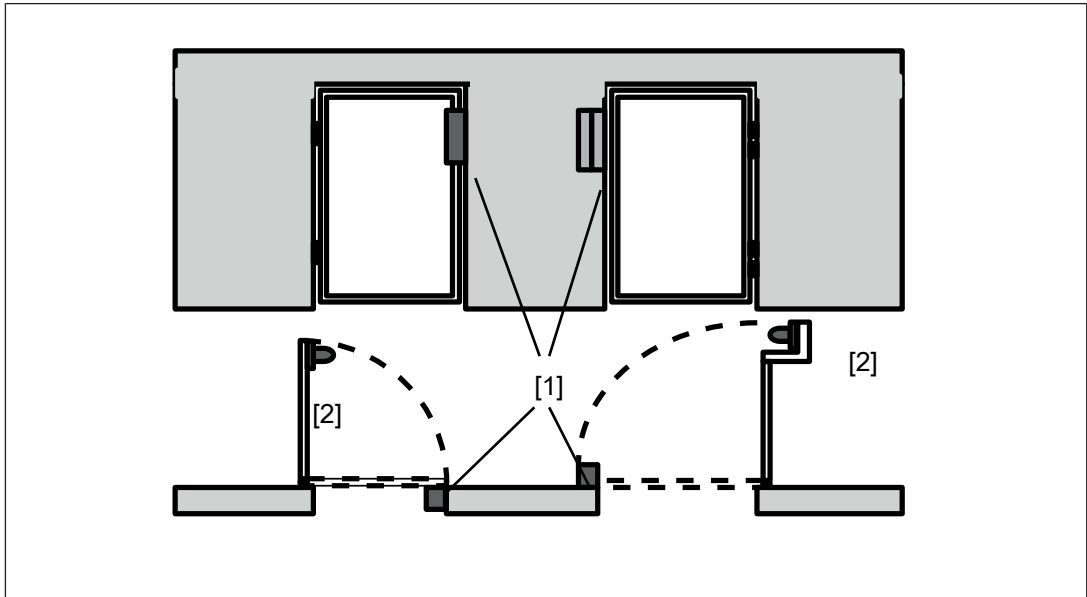



Fig.: Swing gate with internal and external hinge

Legend

- [1] Safety switch on gate frame
- [2] Actuator, installed on swing gate

1. Install the safety switch with the **fixing screws of the safety switch in parallel to the actuator**  38 or **side-on to actuator**  38 on the gate frame.
2. Use two M5 screws to fix the actuator to the gate.

The actuator should engage smoothly into the safety switch.

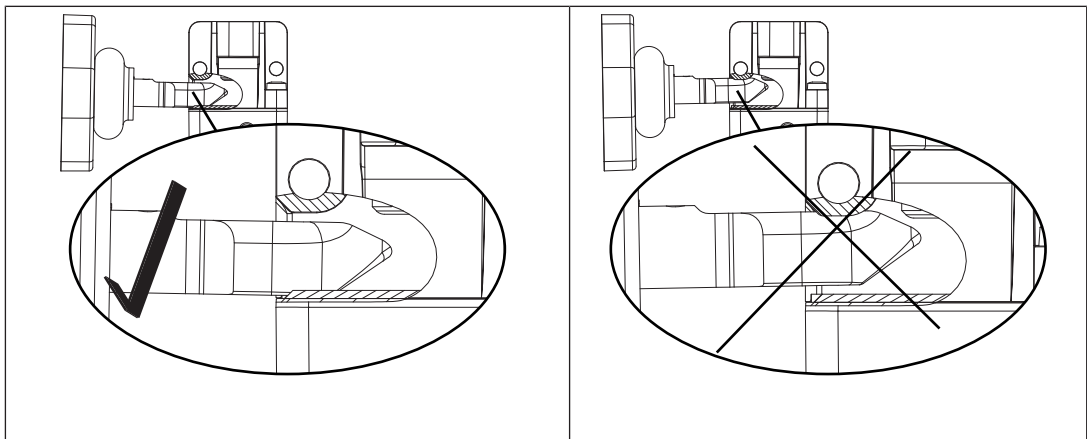

Install the safety switch horizontally at a swing gate

Please note:

Depending on the installation boundary conditions, a larger gate radius may be required (see diagram).

Please contact Pilz when smaller gate radiuses are required.

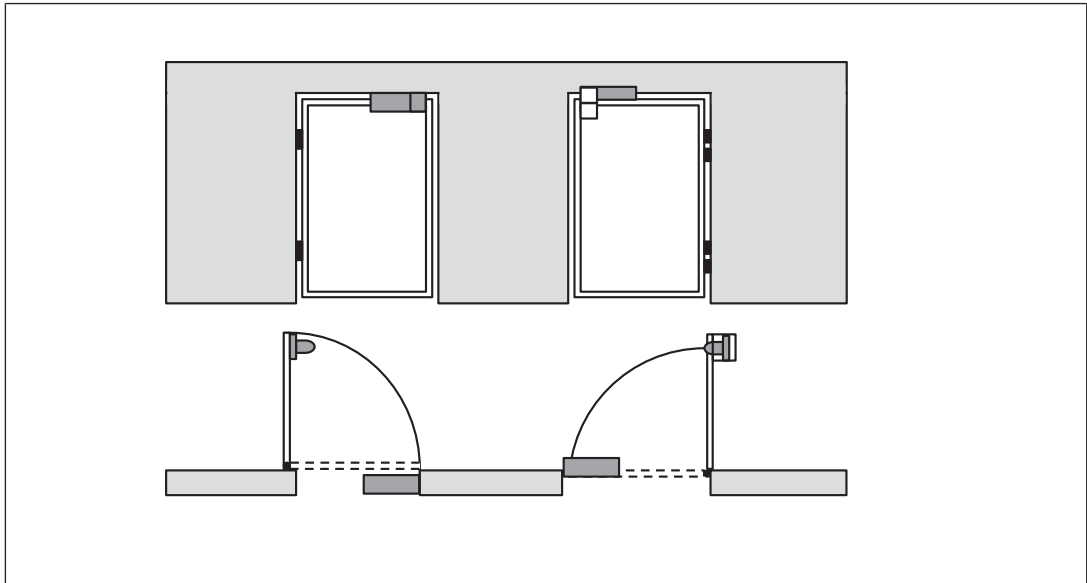

Make sure that a slight shift of the rotation point of the door is maintained when installing the actuator.

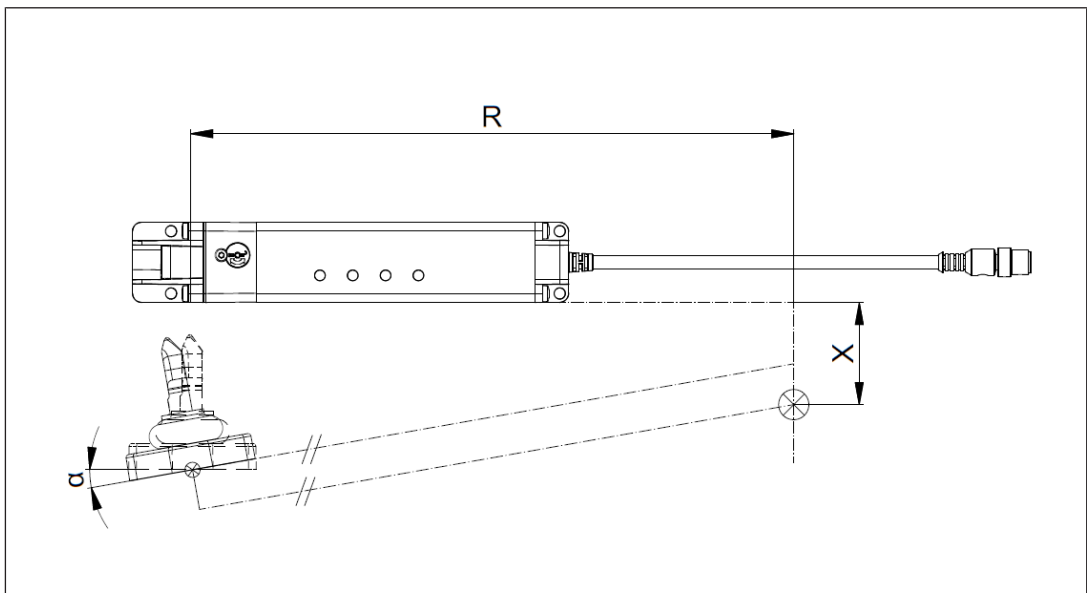

Legend

R The distance of the upper part of the safety switch from the rotation point of the door

X Parallel shift of the actuator

α Tilt angle when installing the actuator

▶ Tilt the actuator during installation by 10° in the following situations:

- $50 \text{ mm} < X < 75 \text{ mm}$ **and** $R < 600 \text{ mm}$
- $X < 50 \text{ mm}$ **and** $R < 500 \text{ mm}$

8.9 Installation with mounting bracket

1. Use two M6 screws to fix the mounting bracket to the gate. The position of the drill holes can be taken from the section entitled Dimensions.
2. Use two M5 screws to fix the actuator to the mounting bracket.

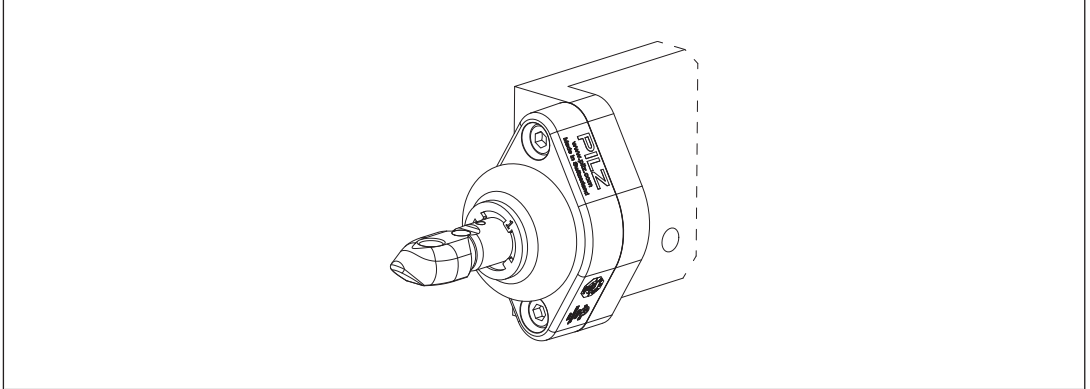

Fig.: Actuator, installed on mounting bracket

8.10 Installation with mounting plate

1. Attach the mounting plate to the swing gate/sliding gate.
2. Use four M5 screws to fix the safety switch [📖 38] to the mounting plate.

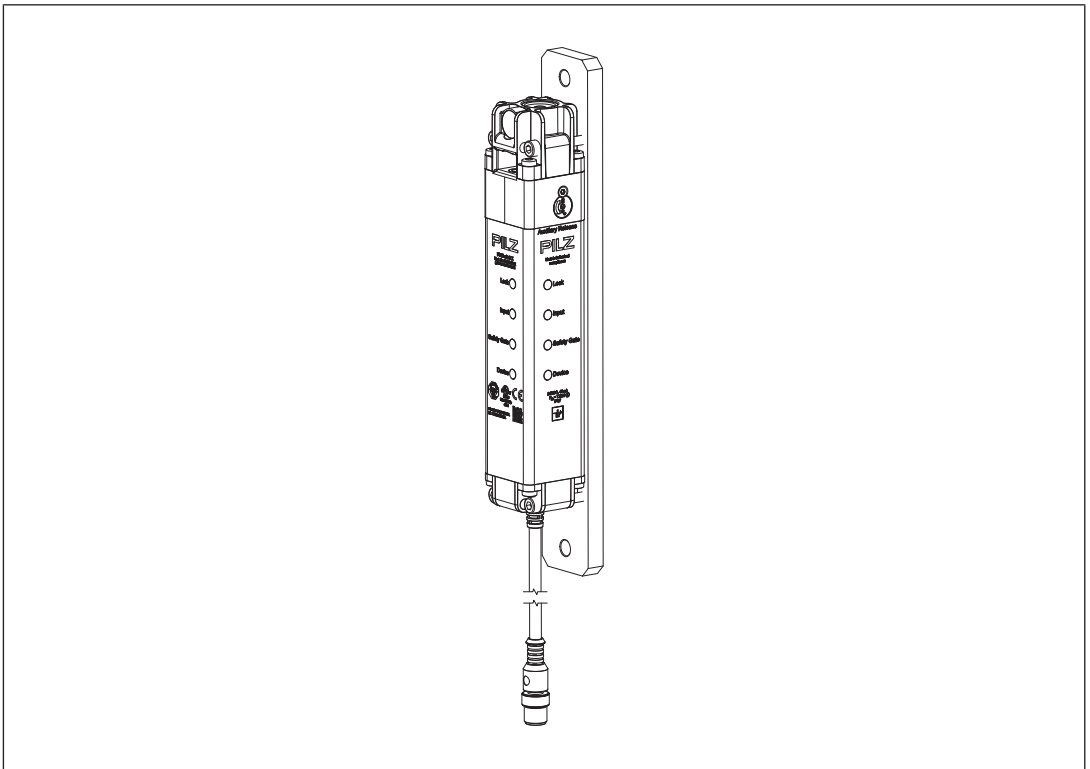

Fig.: Safety switch, installed on mounting plate

8.11 Installing the escape release

8.11.1 Important information

**WARNING!**

Loss of safety function due to the incorrect installation of the escape release!

If the button of the escape release pin is accessible from the outside, the guard locking device can be released from the outside and the safety gates opened, although the hazardous machine is switched on.

Depending on the application, serious injury or death may result.

The escape release should be installed so that it is only accessible from inside the danger zone.

- ▶ The button of the escape release pin must be impossible to reach from a position outside the protected area.
- ▶ Make sure that the escape release cannot be operated unintentionally.
- ▶ Prevent the effect of transverse forces on the escape release.
- ▶ Secure the screw joints with a with a threadlocker.
- ▶ Ensure that the button of the escape release pin is clearly visible and that it is not covered.
- ▶ Make sure that the min. bending radius of the push/pull cable of 60 mm is maintained when using the external escape release.
- ▶ Make sure that the button of the escape release pin does not present a risk.
- ▶ The mounting surface has to completely cover the bottom of the escape release housing. The bottom of the escape release housing must not be accessible after installation.

8.11.2 Installation positions for escape release

The stationary escape release can be installed on the three auxiliary releases in three different directions each.

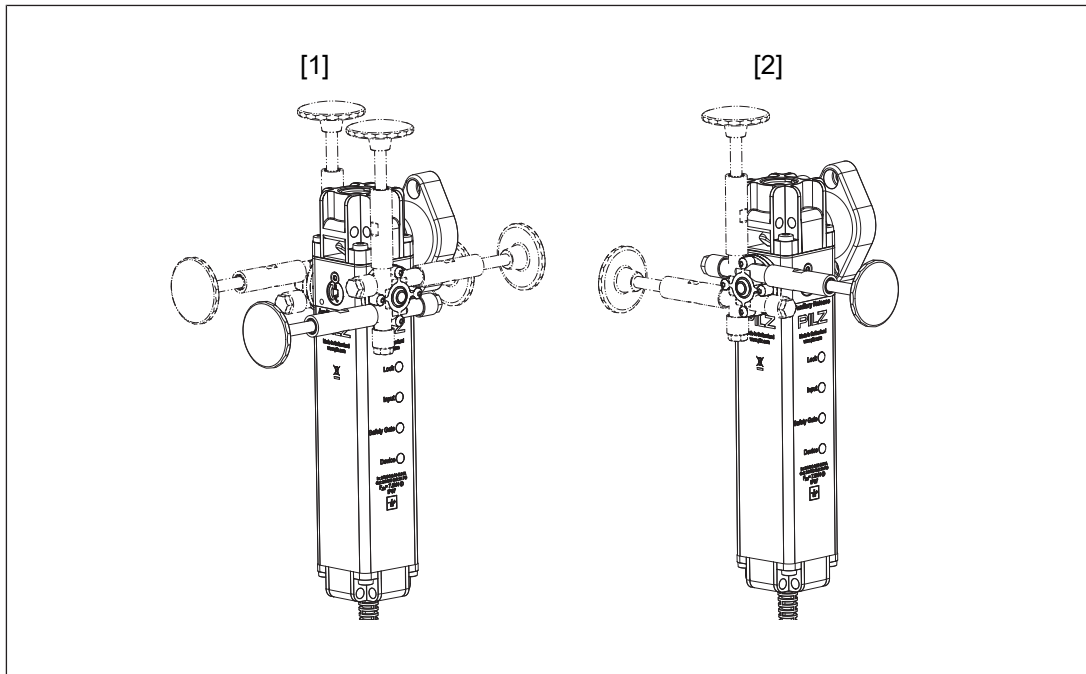

Legend

- [1] Installation options at the sides
- [2] Installation options at the back

The external escape release can be installed on the three auxiliary releases in four different directions each. The push/pull cable can be led out on different sides.

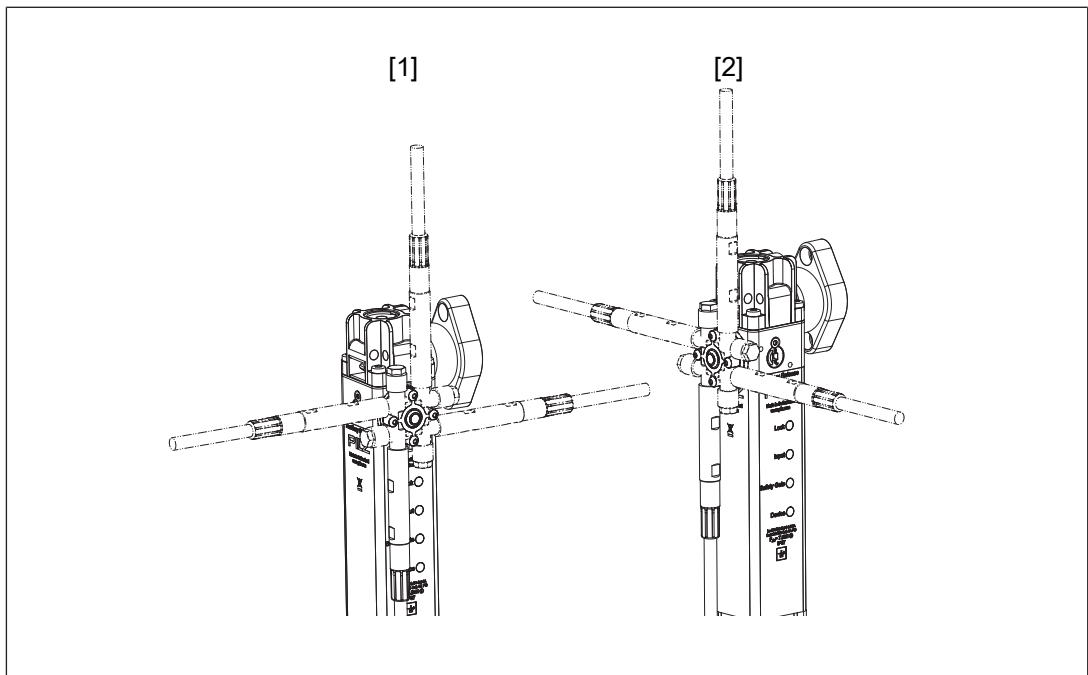

Legend

- [1] Installation options at the sides
- [2] Installation options at the back

8.11.3 Installation stationary escape release

1. Remove the security screw [1] using a Torx T10 screwdriver T10.
2. Screw the adapter disk of the escape release with the two hexagon sockets M3x8 [3] on the safety switch with 1,2 - 1,5 Nm (see diagram). Make sure that the pin of the adapter disk [2] is at the place where the security screw of the auxiliary release [1] used to be.

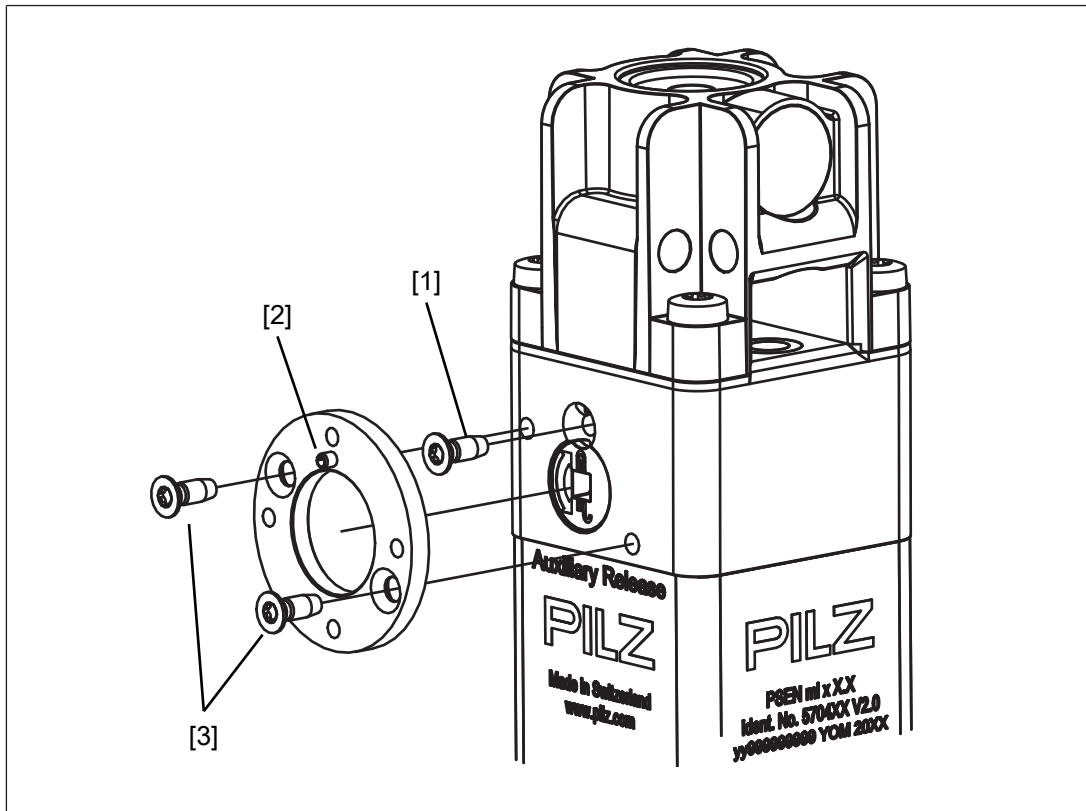

Legend

- [1] Security screw of the auxiliary release
- [2] Pin in the adapter disk
- [3] Hexagon sockets M3x8

3. Screw the escape release with the 4 raised head screws M3x12 to the adapter disk with 1,2 - 1,5 Nm (see diagram).
 - ▶ The button of the escape release pin can be removed for the installation (e.g. when the escape release pin is to be run through a wall). The button of the escape release pin must be secured again with a threadlocker and hand-tightened after escape release installation is complete
 - ▶ To bridge larger distances the escape release pin can be extended by a max. of 25 mm two times (see [Order reference: Accessories](#)  71]).

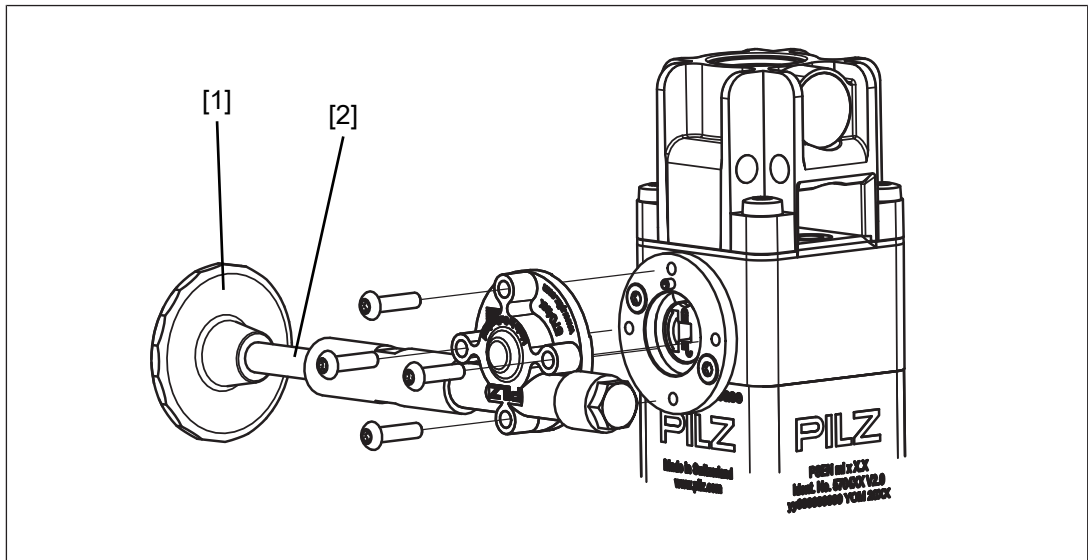
**Legend**

- [1] Button of the escape release pin
- [2] Escape release pin

8.11.4 Installation external escape release

1. Remove the security screw [1] using a Torx T10 screwdriver T10.
2. Screw the adapter disk of the escape release with the two hexagon sockets M3x8 [3] on the safety switch with 1,2 - 1,5 Nm (see diagram). Make sure that the pin of the adapter disk [2] is at the place where the security screw of the auxiliary release [1] used to be.

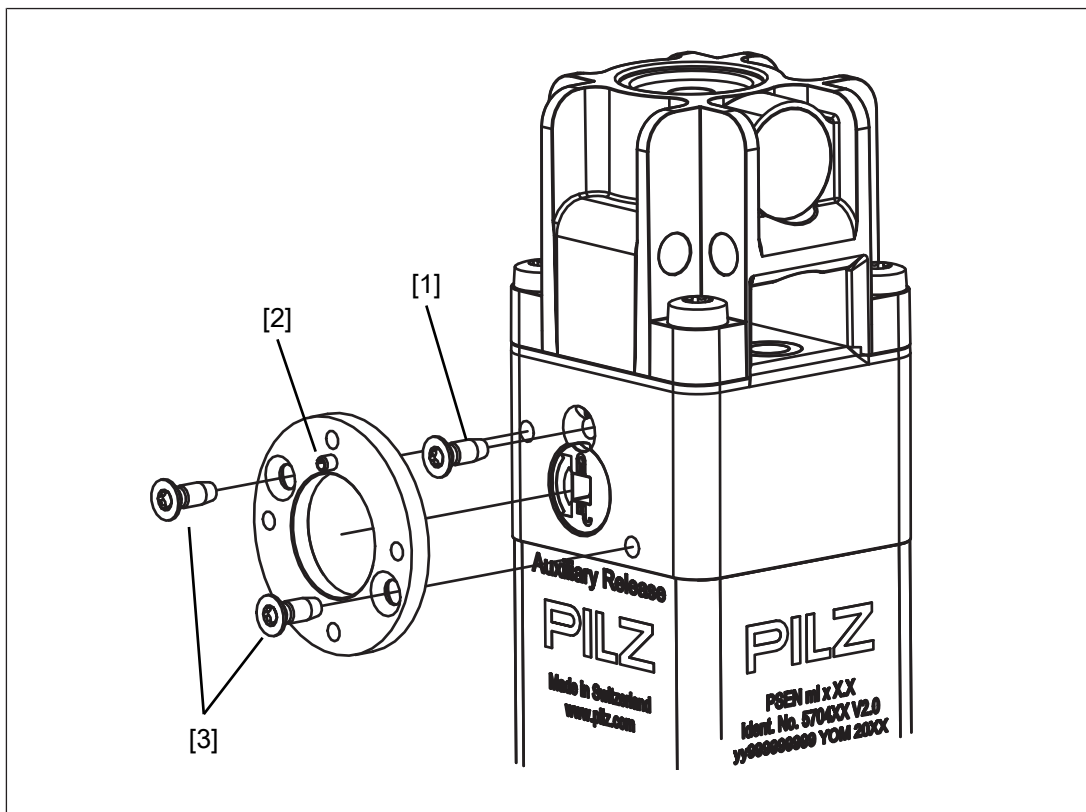
**Legend**

- [1] Security screw of the auxiliary release
 - [2] Pin in the adapter disk
 - [3] Hexagon sockets M3x8
3. Screw the escape release with the 4 raised head screws M3x12 to the adapter disk with 1,2 - 1,5 Nm (see diagram).

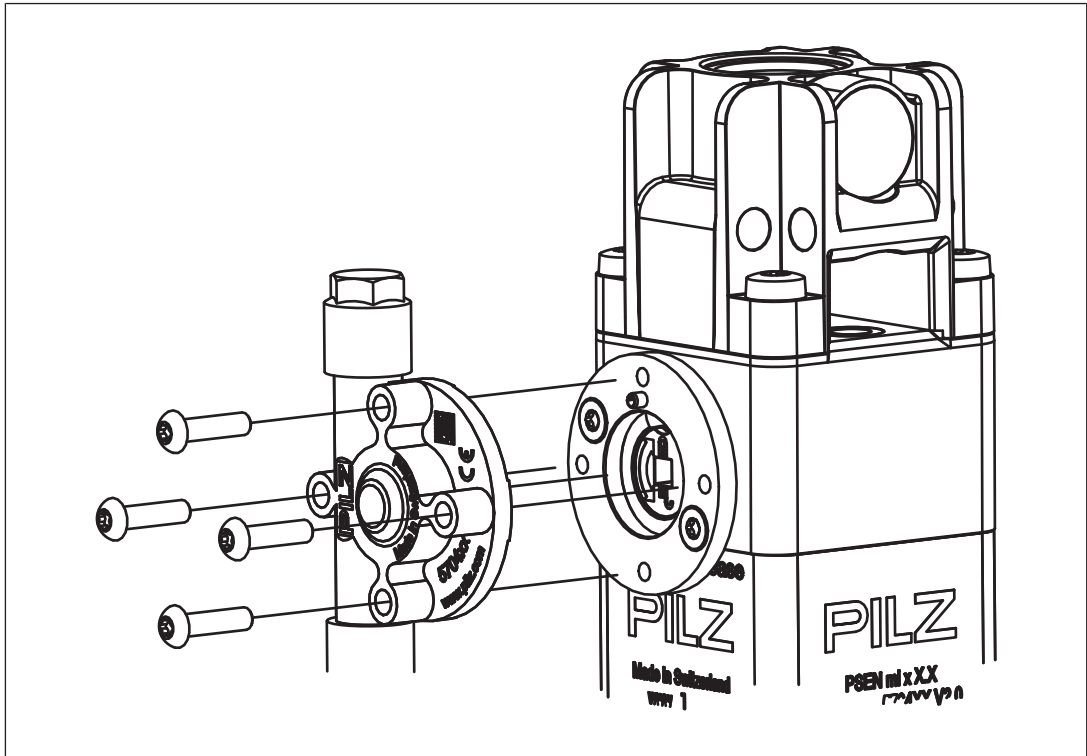

4. Screw the housing of the escape release with the screws [1] to a mounting surface with 6 - 6,5 Nm (see diagram).
 - ▶ The screws of the push/pull cable [2] can be loosened to make installation easier (e.g. when the push/pull cable is to be run through a wall). The screws must be fixed with 6 - 6,5 Nm after the escape release is installed.

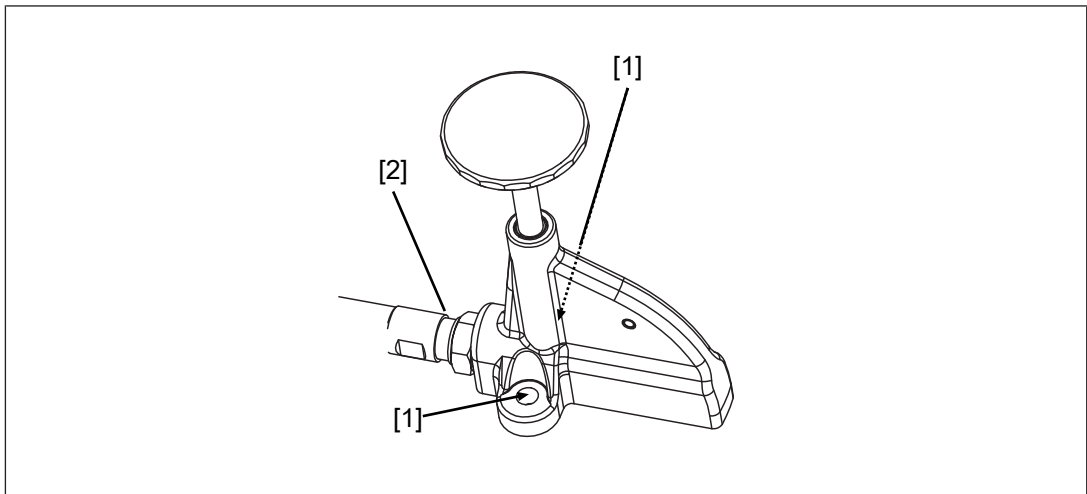

Legend

- [1] Screwing the escape release to the mounting area
- [2] Screwing the cable

8.11.5 Uninstalling the escape release

If the push/pull cable is to be run through a conduit pipe, the cable has to be uninstalled at the escape release first.

Prerequisites

- ▶ The conduit pipe must have a diameter of at least 12 mm.

Procedure:

1. Lift off the cover [1] (e.g. with a screwdriver with a flat blade).

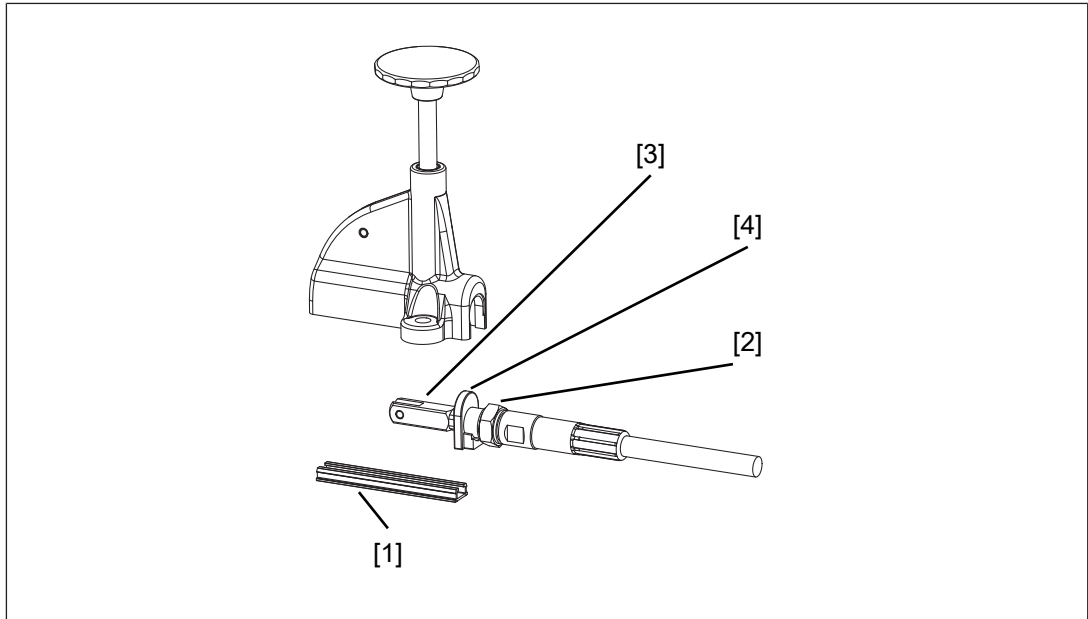

Legend

- [1] Cover
- [2] Nut M10 x 0,75
- [3] Fork head
- [4] Slot nut

2. Loosen the nut [2].
3. Pull out the push/pull cable with the slot nut [4] and remove the slot nut and the nut [2] from the cable.
4. Run the cable through the conduit pipe.
5. Push the nut [2] and the slot nut [4] over the fork head [3] back on the cable.
6. Push the cable with the fork head [3] on the fork in the escape release. The slot nut [4] must be fitted into the nut again.
7. Tighten the nut [2] with 6 - 6,5 Nm.
8. Put the lid [1] back on.

9 Adjustment

Please note:

- ▶ Safety switch and actuator must be aligned correctly
- ▶ Distances are maintained as stated in the following diagram
- ▶ Actuator is centred (see [Centre bolt in actuator housing](#) [39])
- ▶ Always test the function with a connected evaluation device.
- ▶ When installing an external or stationary escape release, check the function of the escape release with a connected evaluation device.

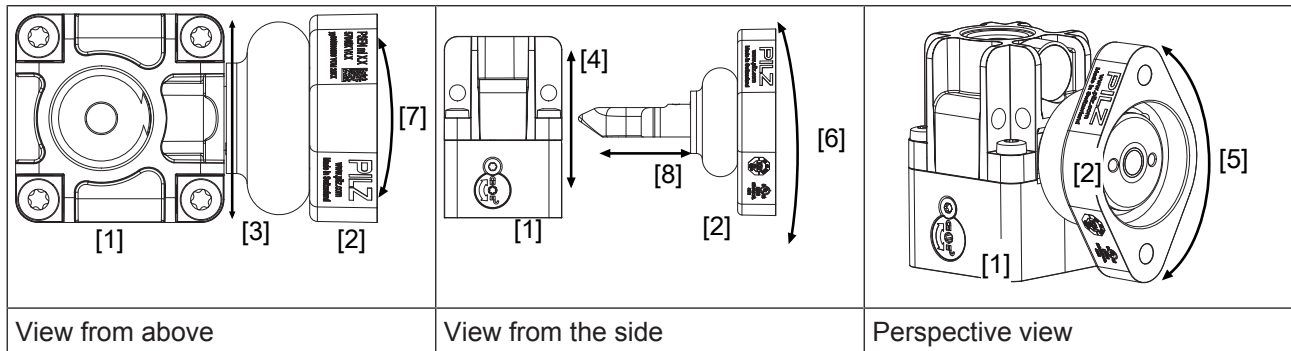

[1]	Safety switch	
[2]	Actuator	
[3]	Max. lateral offset	+/-3,0 mm
[4]	Max. vertical offset	+/-3,0 mm
[5]	Max. angular offset around the X axis	+/-2,0 deg
[6]	Max. angular offset around the Y axis	+/-2,5 deg
[7]	Max. angular offset around the Z axis	+/-7,5 deg
[8]	Max. offset in closing direction	+/-2 mm

Attach safety switch and actuator

Once the safety switch and actuator are correctly aligned, the actuator's screw connection must be tightened.

1. Tighten up one M5 screw.
2. For applications with increased safety requirements (e.g. SIL CL 2 PL d), swap the second M5 screw for an M5 locking screw.
3. Tighten up the M5 screw or M5 locking screw.

Please note the max. torque setting stated in the [Technical details](#) [65].

10 Operation



NOTICE

The safety function should be checked after initial commissioning and each time the plant/machine is changed. The safety functions may only be checked by qualified personnel.

Status indicators:





- ▶ "Device" LED illuminates green: The unit is ready for operation
- ▶ "Safety Gate" LED lights up yellow: Actuator is within the response range
- ▶ "Lock" LED lights up green: Guard locking active
- ▶ "Input" LED lights independently of the status of safety inputs S11 and S21

Legend:













	LED off
	LED on
	LED flashes (500 ms on, 500 ms off)
	LED flashes quickly (50 ms on, 950 ms off)
	LED flashes very quickly (25 ms on, 475 ms off)



10.1 Normal mode

LED status				Switch status
Device	Safety Gate	Input	Lock	
Green	Yellow	Yellow	Green	PSEN ml s 1.1 is started
Green	LED off	LED off	LED off	Safety gate open, actuator not detected, guard locking deactivated, safety inputs S11 and S21 are low
Green	LED off	Yellow	LED off	Safety gate open, actuator not detected, guard locking deactivated, safety inputs S11 and S21 are high
Green	Yellow	Yellow	LED off	Safety gate closed, actuator not detected, guard locking deactivated, safety inputs S11 and S21 are high













LED status				Switch status
Device	Safety Gate	Input	Lock	
 Green	 Yellow	 Yellow	 Green	Safety gate closed, actuator detected, guard locking activated

Warnings

LED status				Switch status	Remedy / measure
Device	Safety Gate	Input	Lock		
 Green	 Yellow	 Yellow	 Green	Safety gate closed, actuator detected, guard locking cannot be activated / deactivated	Check the actuator's alignment [ 53] to the safety switch.
				The supply voltage to safety inputs S31 and S41 was switched back on before the auxiliary release screw was turned back.	Turn back the auxiliary release screw and then switch the supply voltage on (see Recommissioning [ 21]).
 Yellow	Display not definitive	 Yellow	Display not definitive	Safety switch active despite over or undervoltage	Check the supply voltage. If safety inputs S31 and S41 are activated or deactivated while an undervoltage warning is present, the safety switch switches to a fault condition.
 Green	Display not definitive	 Yellow	Display not definitive	Partial operation: One input is low, after both inputs were high	Open both inputs (switch to normal operation).
 Red	Display not definitive	 Yellow	 Green	Partial operation lock: One input is low, after both inputs were high	Open both inputs. This will cancel the lock.

LED status				Switch status	Remedy / measure
Device	Safety Gate	Input	Lock		
 Red	Display not definitive	 Yellow	 Green	Partial operation lock: Both inputs are high	

10.2 Error display

LED status				Switch status	Remedy / measure
Device	Safety Gate	Input	Lock		
 Red	 Yellow	 Yellow	Display not definitive	Safety switch deactivated due to under or over-voltage	Check the supply voltage and switch the supply voltage off and then on again.
 Red	Previous LED display is retained		Display not definitive	Safety outputs in fault condition	Check the wiring and switch the supply voltage off and then on again.
 Red				Auxiliary release/escape release activated	<ul style="list-style-type: none"> ▶ Auxiliary release: Turn back the auxiliary release screw and then switch the supply voltage on (see Recommissioning [21]). ▶ Escape release: Pull the button of the escape release pin back again and then switch on the voltage supply again (see Recommissioning under escape release [23]).
				Error	Please contact Pilz.
 Red	Display not definitive			Safety switch does not start	Change the safety switch.
 Green	 Yellow	 Yellow	Display not definitive	Wrong actuator	Use the actuator PSEN ml 1.1.

11 Checks and maintenance

Regular inspection of the switch function is required to guarantee the trouble-free, long-term function.

If the interlock and guard locking system is only used rarely (opening and closing the safety gate and activating/deactivating the guard locking device), a manual function test is required.

The correct function of the device should be checked at regular intervals and after each error.

Test intervals in accordance with EN ISO 14119:

- ▶ for SIL CL 3/PL e at least 1x per month
- ▶ for SIL CL 2/PL d at least 1x per year

The Appendix contains a [Check list](#)  75], which should help you perform the test.

Visual inspection:

- ▶ Check that the seal on the security screw on the auxiliary release is intact. If the seal is not intact, make sure that the security screw is inserted and use varnish to seal the security screw.
- ▶ Check the safety switch and actuator for damage.
- ▶ Make sure that the safety switch and actuator are firmly secured.
- ▶ Check the offset of the safety switch and actuator.
 - Max. lateral offset
 - Max. angular offset
 - Max. vertical offset
- ▶ Check that the wiring is correct.
- ▶ Remove any dirt from the safety switch and actuator.

Function test

- ▶ The actuator is detected and at the safety outputs 12 and 22 there is a high signal after detection of the actuator.
- ▶ The guard locking device can be activated/deactivated when the safety inputs S31 and S41 are activated.
- ▶ Under these conditions there is a high signal at safety outputs 12 and 22:
 - Actuator is detected **and**
 - Guard locking pin has successfully been activated (guard locking pin is in the locked position) **and**
 - There is a high signal at the inputs S11 and S21

If one of these conditions is not met, the signal at the safety outputs will be low.

Escape release

- ▶ Test whether the button of the escape release pin can be detected and reached.
- ▶ Check the function of the escape release.

12 Dimensions

<p>Safety switch</p>	<p>Actuator</p>

Distance between safety switch mounting surface and actuator mounting surface

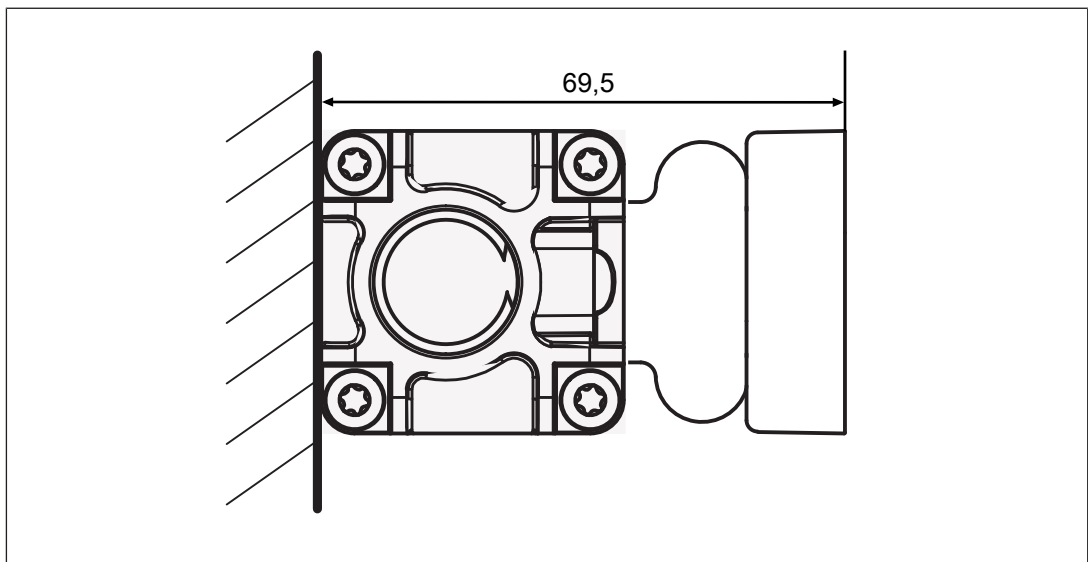

Mounting plate (see [Accessories \[71\]](#))

Fig.: Order no.: 570 490

Mounting bracket for sliding gate (see [Accessories \[71\]](#))

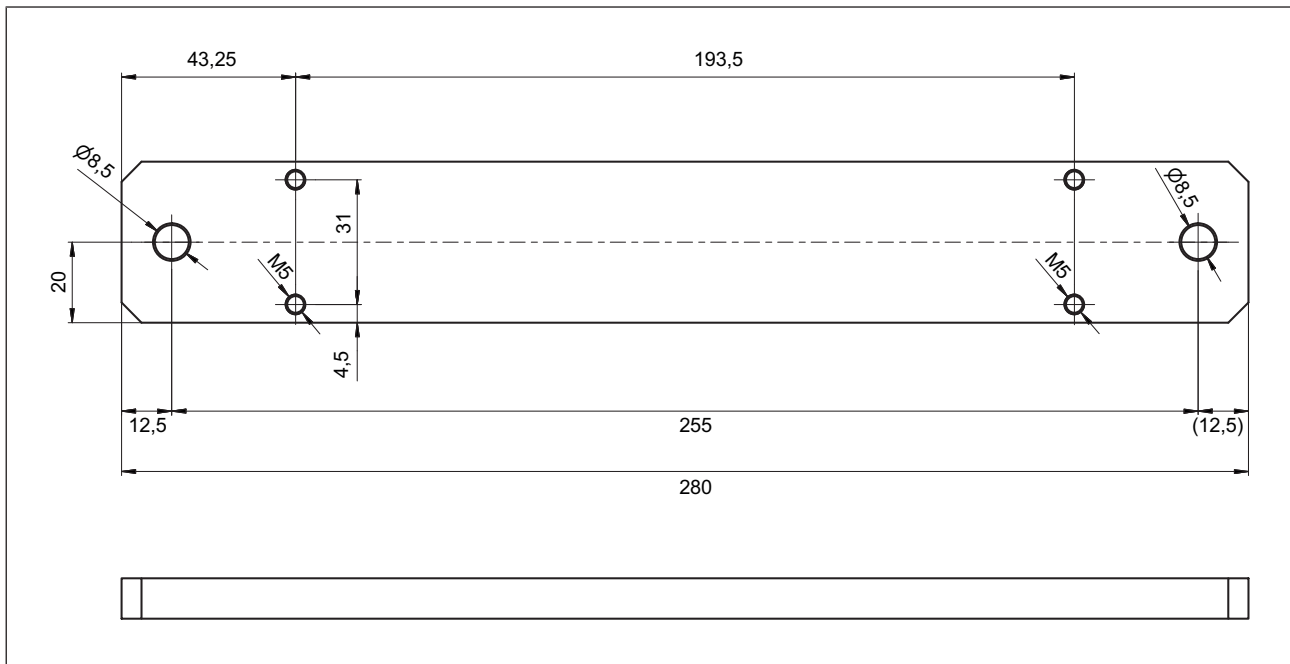
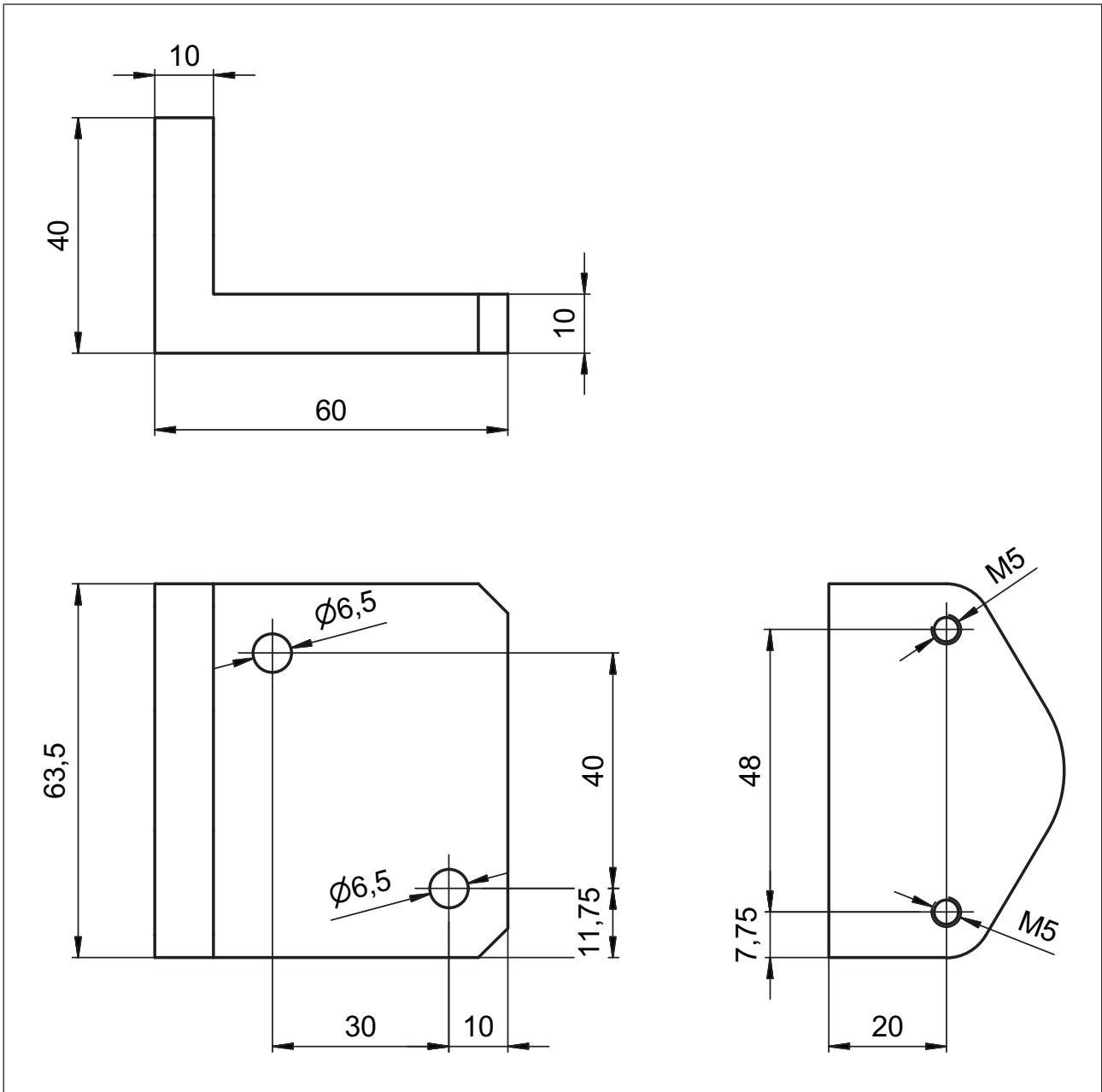

Fig.: Order no.: 570 492

Mounting bracket for swing gate (see [Accessories \[71\]](#))

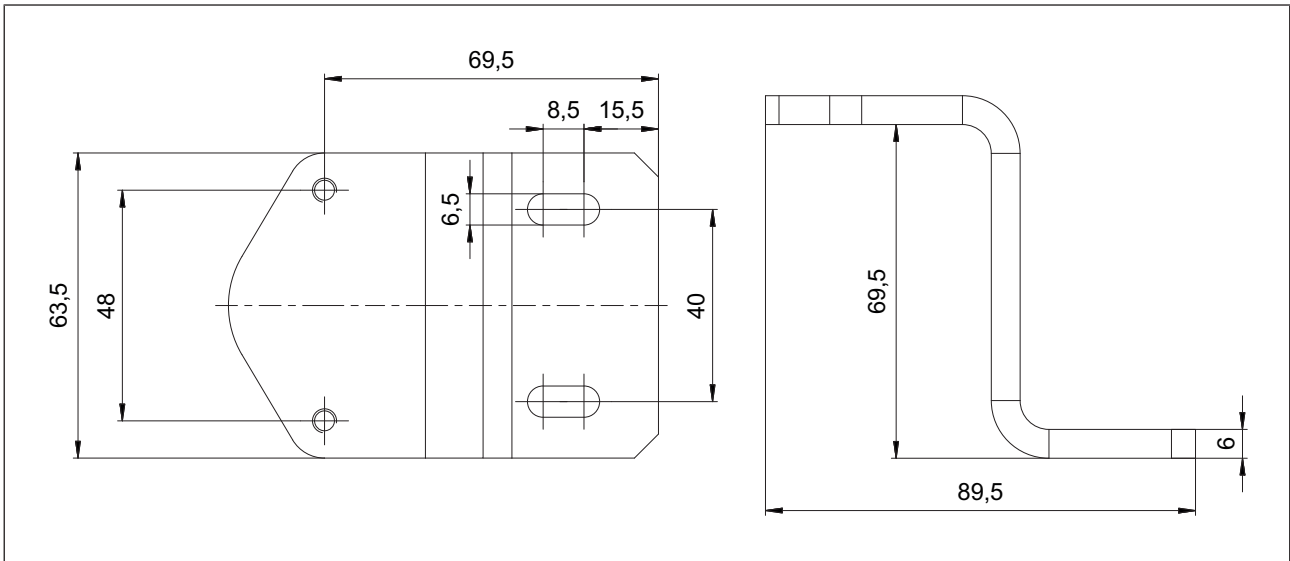

Fig.: Order no.: 570 493

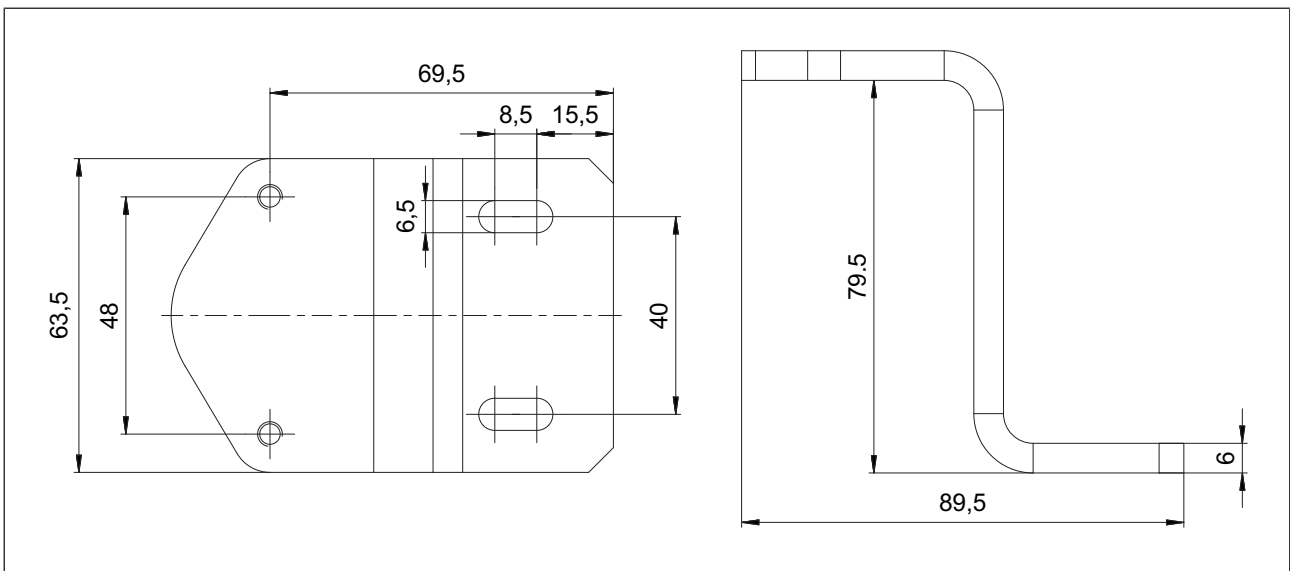

Fig.: Order no.: 570 494

Mounting bracket with handle unit for sliding gate (see [Accessories \[71\]](#))

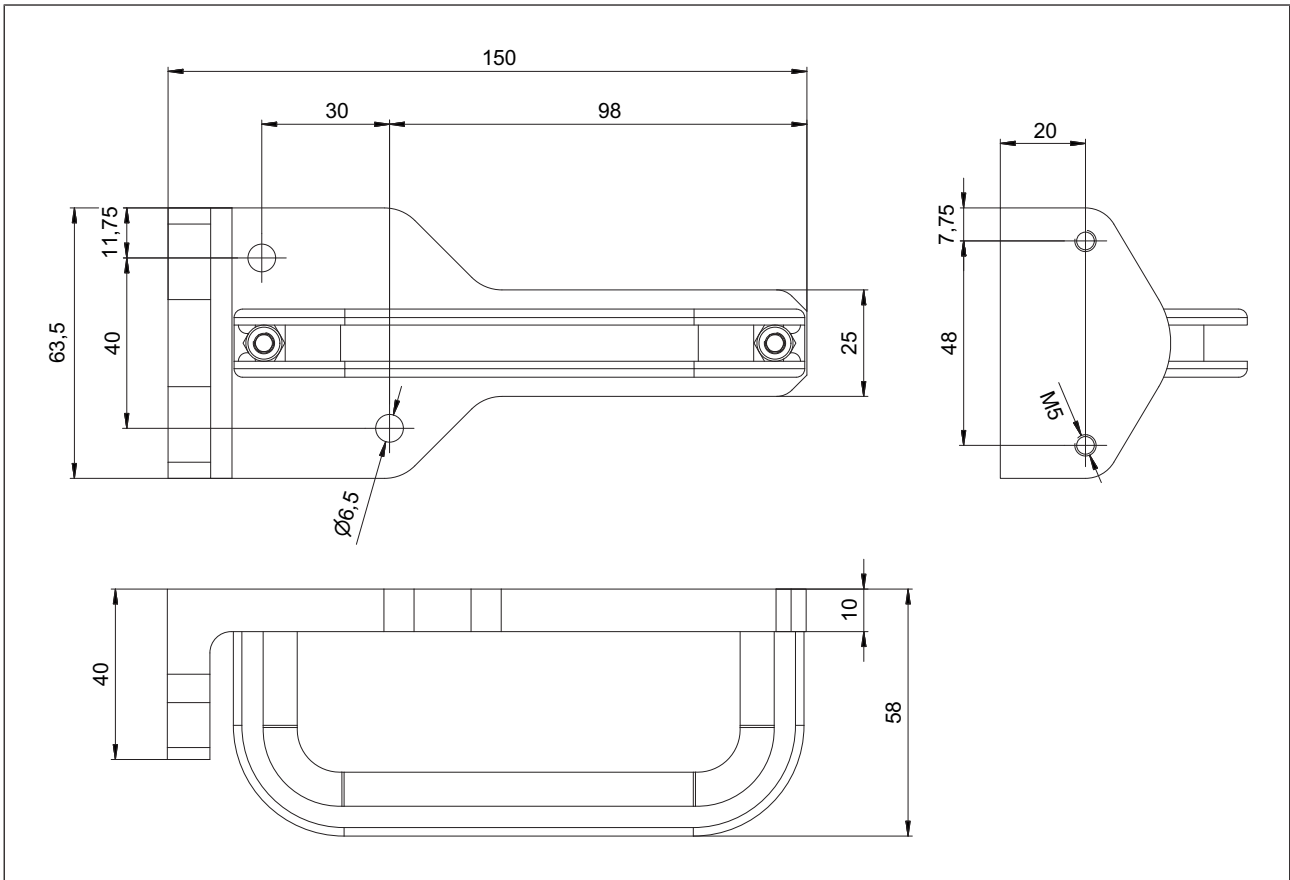

Fig.: Order no.: 570 495

Mounting bracket with handle unit for swing gate (see [Accessories \[71\]](#))

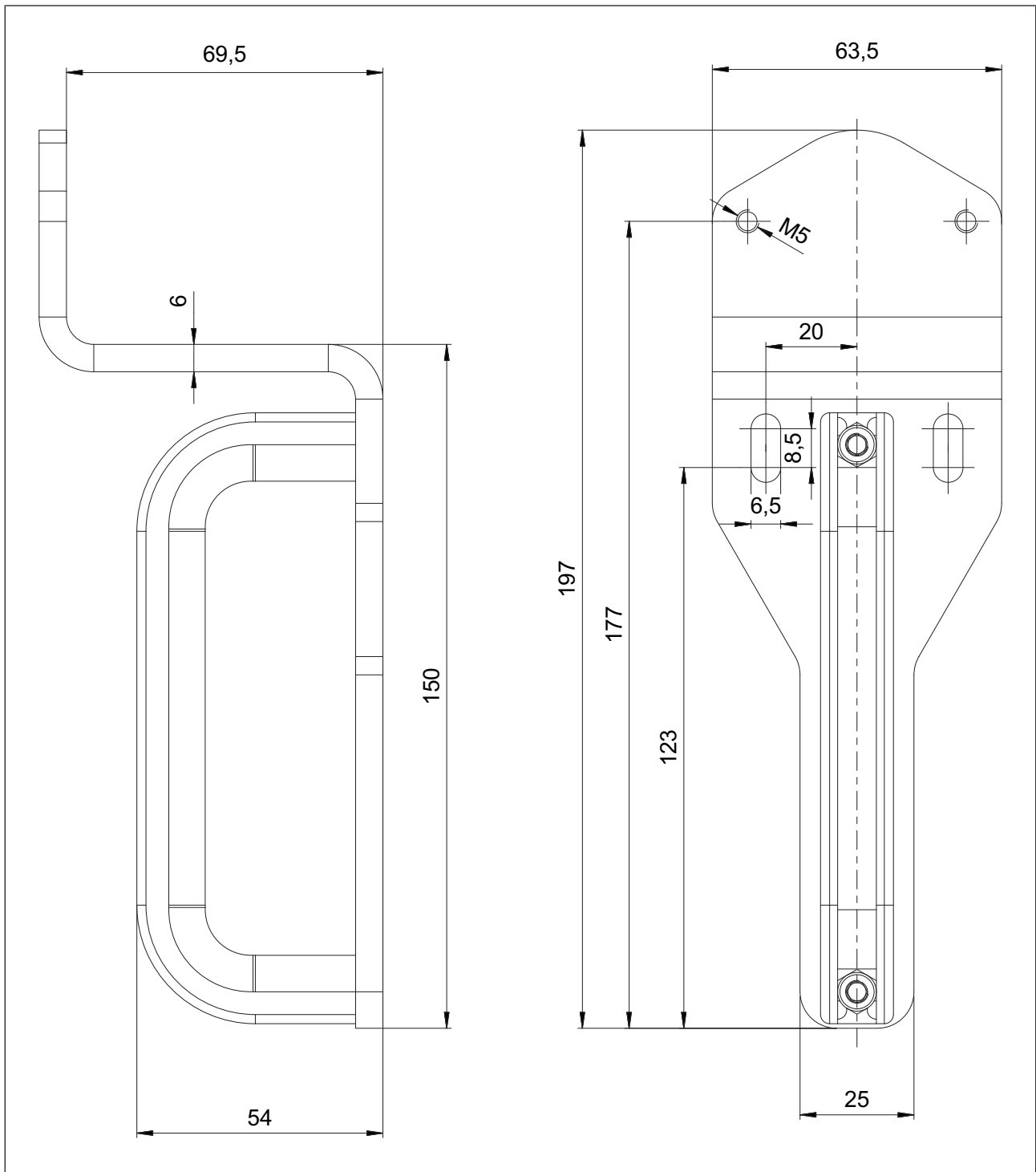

Fig.: Order no.: 570 496

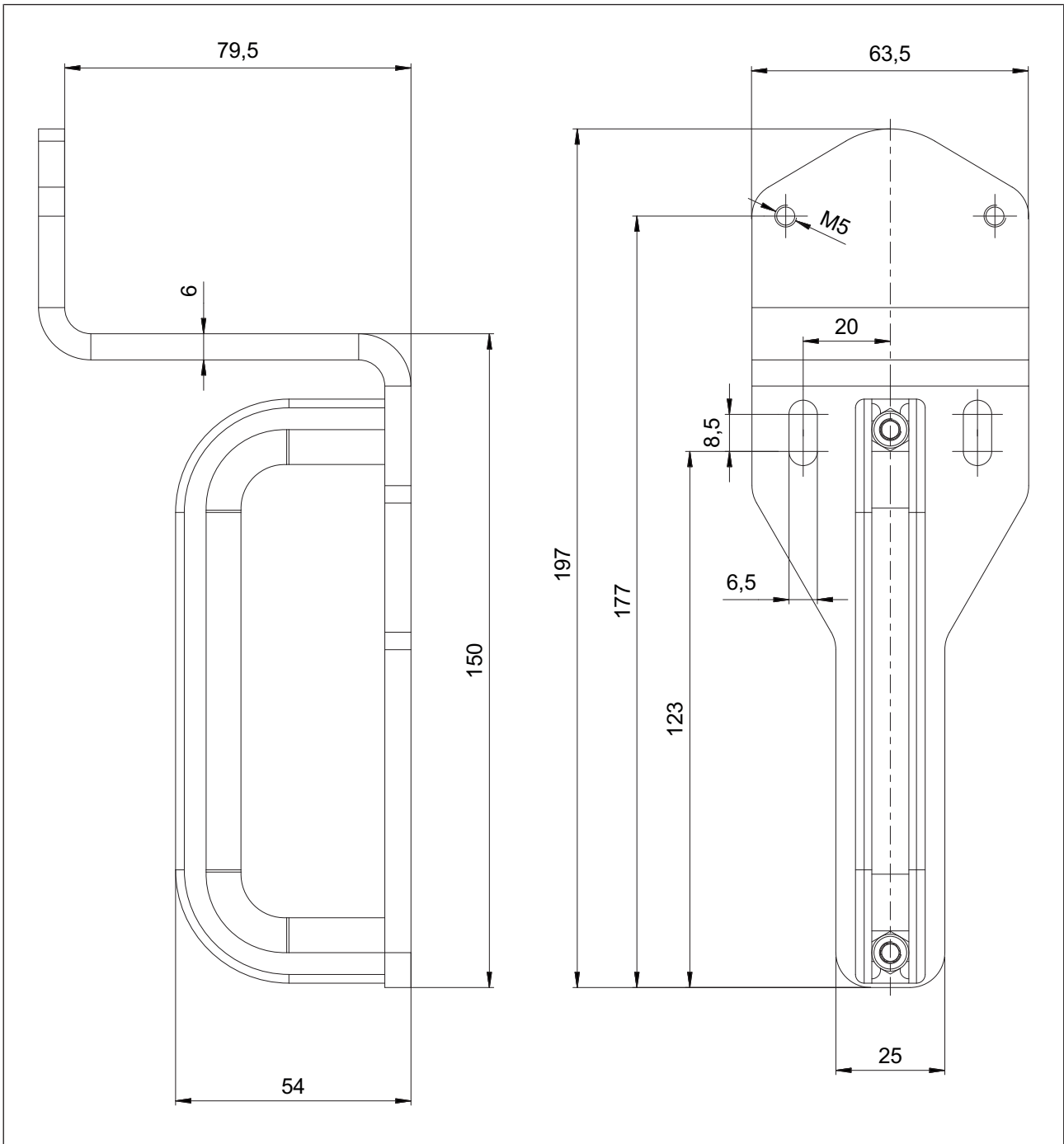

Fig.: Order no.: 570 497

13 Technical details

General	
Approvals	CE, FCC, IC, TÜV, cULus Listed
Sensor's mode of operation	Transponder
Coding level in accordance with EN ISO 14119	Low
Design in accordance with EN ISO 14119	4
Classification in accordance with EN 60947-5-3	PDDB
Pilz coding type	Coded
Transponder	
Frequency band	122 kHz - 128 kHz
Max. transmitter output	15 mW
Electrical data	
Supply voltage	
Voltage	24 V
Kind	DC
Voltage tolerance	-20 %/+20 %
Output of external power supply (DC)	1 W
Max. switching frequency	1 Hz
Magnet. supply voltage	24 V
Max. solenoid current $t < 150$ ms	1 A
Max. cable capacitance at the safety outputs	
No-load, PNOZ with relay contacts	40 nF
PNOZmulti, PNOZelog, PSS	70 nF
Max. inrush current impulse	
Current pulse, A1	5 A
Pulse duration, A1	0,0002 ms
Max. unit fuse protection in accordance with UL	3 A
No-load current	40 mA
Inputs	
Number	4
Voltage at inputs	24 V DC
Current at solenoid input	500 mA
Input current range	1,6 - 3 mA
Semiconductor outputs	
OSSD safety outputs	2
Signal outputs	1
Switching current per output	100 mA
Breaking capacity per output	2,4 W
Potential isolation from system voltage	No
Short circuit-proof	yes
Residual current at outputs	100 μ A
Voltage drop at OSSDs	1 V
Conditional rated short circuit current	100 A

Semiconductor outputs	
Lowest operating current	1 mA
Utilisation category in accordance with EN 60947-1	DC-13
Times	
Test pulse duration, safety outputs	450 µs
Switch-on delay	
after UB is applied	1,1 s
Inputs typ.	1 ms
Inputs max.	3 ms
Actuator typ.	30 ms
Actuator max.	50 ms
Delay-on de-energisation	
Inputs typ.	3 ms
Inputs max.	5 ms
Actuator typ.	30 ms
Actuator max.	40 ms
Risk time in accordance with EN 60947-5-3	260 ms
Supply interruption before de-energisation	20 ms
Simultaneity, channel 1 and 2 max.	20 ms
Pulse duration Lock/Unlock Request	350 - 400 ms
Processing time activate/deactivate guard locking	100 ms
Environmental data	
Temperature of metal surface at ambient temperature: 25 °C	40 °C
Ambient temperature	
In accordance with the standard	EN 60068-2-14
Temperature range	0 - 60 °C
Storage temperature	
In accordance with the standard	EN 60068-2-1/-2
Temperature range	-25 - 70 °C
Climatic suitability	
In accordance with the standard	EN 60068-2-78
Humidity	93 % r. h. at 40 °C
EMC	EN 55011: class A, EN 60947-5-3, EN 61326-3-1
Vibration	
In accordance with the standard	EN 60068-2-6
Frequency	10 - 55 Hz
Amplitude	1 mm
Shock stress	
In accordance with the standard	EN 60068-2-27
Number of shocks	3
Acceleration	30g
Duration	11 ms
Airgap creepage	
Overvoltage category	III
Pollution degree	3

Environmental data	
Rated insulation voltage	75 V
Rated impulse withstand voltage	0,8 kV
Protection type	
Housing	IP67
In accordance with UL	type 1
Mechanical data	
Length of cable with connector	230 mm
Min. bending radius (fixed permanently) K1	5 x Ø
Min. bending radius (moving) K1	10 x Ø
Cable diameter K1	6,5 mm
Escape release available	No
Mechanical life	1,000,000 cycles
Holding force FZh	
Fixing screws in parallel to actuator	7.500 N
Fixing screws side-on to actuator	5.000 N
Holding force F1Max in accordance with ISO 14119	
Fixing screws in parallel to actuator	15.000 N
Fixing screws side-on to actuator	10.000 N
Latching force	30 N
Max. vertical offset	+/-3,0 mm
Max. lateral offset	+/-3,0 mm
Max. angular offset around the X axis	+/-2,0 deg
Max. angular offset around the Y axis	+/-2,5 deg
Max. angular offset around the Z axis	+/-7,5 deg
Max. offset in closing direction	+/-2 mm
Max. retract speed of actuator	0,3 m/s
Actuator 1	PSEN ml 1.1
Min. distance between safety switches	0 mm
Connection type	M12, 12-pin male connector
Cable	LiYY 12 x 0.25 mm2
Material	Aluminium, stainless steel, plastic, galvanised steel, Zn
Max. torque setting for fixing screws	6 - 6,5 Nm
Max. torque setting escape release	1,2 - 1,5 Nm
Max. torque setting for mounting plate	22 - 24 Nm
Max. torque setting for mounting bracket	14 - 16 Nm
Min. gate radius	300 mm
Dimensions	
Height	217,2 mm
Width	40 mm
Depth	40 mm
Actuator dimensions	
Height	63,5 mm
Width	40 mm
Depth	67,2 mm

Mechanical data	
Weight of safety switch	950 g
Weight of actuator	145 g
Weight	1.100 g

Where standards are undated, the 2015-11 latest editions shall apply.

13.1 Classification according to ZVEI, CB24I

The following tables describe the classes and specific values of the product interface and the classes of interfaces compatible with it. The classification is described in the ZVEI position paper "Classification of Binary 24 V Interfaces - Functional Safety aspects covered by dynamic testing".

Inputs

Drain		Source	
Safety switch	C2	Safety control system	C2, C3

Drain parameters	Min.	Typ.	Max.
Test impulse duration	-	-	500 µs
Input resistance	9 kOhm	-	-
Capacitive load	-	-	1 nF
Test impulse interval	1 ms	-	-

Solenoid inputs

Drain		Source	
Safety switch	C2	Safety control system	C2, C3

Drain parameters	Min.	Typ.	Max.
Test impulse duration	-	-	500 µs
Input resistance	16 Ohm	-	
Capacitive load	-	-	1,5 nF

Safe 1-pole HL outputs

Source		Drain	
Safety switch	C2	Evaluation device	C1, C2

Source parameters	Min.	Typ.	Max.
Test impulse duration	-	-	450 µs
Rated current	-	-	0,1 A
Capacitive load	-	-	70 nF

13.2 Safety characteristic data



NOTICE
 You must comply with the safety characteristic data in order to achieve the required safety level for your plant/machine.

Operating mode	EN ISO 13849-1: 2015 PL	EN ISO 13849-1: 2015 Category	EN IEC 62061 SIL CL	EN IEC 62061 PFH _D [1/h]	Lambda d/ Lambda	EN ISO 13849-1 2015, EN IEC B10D	EN ISO 13849-1: 2015 T _M [year]
1-ch. guard locking	PL d	Cat. 2	SIL CL 2	2,54E-08	-	-	20
2-ch. guard locking	PL e	Cat. 4	SIL CL 3	2,54E-08	-	-	20
2-ch. OSSD	PL e	Cat. 4	SIL CL 3	1,90E-08	-	-	20

All the units used within a safety function must be considered when calculating the safety characteristic data.



INFORMATION
 A safety function's SIL/PL values are **not** identical to the SIL/PL values of the units that are used and may be different. We recommend that you use the PAScal software tool to calculate the safety function's SIL/PL values.



NOTICE
 Be sure that you observe the mechanical life. The safety characteristic data are only valid as long as the values of mechanical life are met.

14 Supplementary data

14.1 Radio approval

USA/Canada	
FCC ID: VT8-PSENML	
IC: 7482A-PSENML	
FCC/IC-Requirements:	
This product complies with Part 15 of the FCC Rules and with Industry Canada licence-exempt RSS standards.	
Operation is subject to the following two conditions:	
1) this product may not cause harmful interference, and	
2) this product must accept any interference received, including interference that may cause undesired operation.	
Changes or modifications made to this product not expressly approved by Pilz may void the FCC authorization to operate this equipment.	
NOTE: This equipment has been tested and found to comply with the limits for a Class A digital device, pursuant to Part 15 of the FCC Rules. These limits are designed to provide reasonable protection against harmful interference when the equipment is operated in a commercial environment. This equipment generates, uses, and can radiate radio frequency energy and, if not installed and used in accordance with the instruction manual, may cause harmful interference to radio communications. Operation of this equipment in a residential area is likely to cause harmful interference in which case the user will be required to correct the interference at his own expense.	
Le présent produit est conforme aux CNR d'Industrie Canada applicables aux appareils radio exempts de licence. L'exploitation est autorisée aux deux conditions suivantes:	
(1) le produit ne doit pas produire de brouillage, et	
(2) l'utilisateur de le produit doit accepter tout brouillage radioélectrique subi, même si le brouillage est susceptible d'en compromettre le fonctionnement.	

14.2 Technical details for mounting bracket without handle unit

General	570492	570493	570494
Approvals	CE	CE	CE
Mechanical data	570492	570493	570494
Holding force FZh in accordance with ISO 14119	–	3000 N	3000 N
Holding force F1max in accordance with ISO 14119	–	6000 N	6000 N
Weight	420 g	420 g	445 g

14.3 Technical details for mounting bracket with handle unit

General	570495	570496	570497
Approvals	CE	CE	CE
Mechanical data	570495	570496	570497
Holding force FZh in accordance with ISO 14119	3000 N	3000 N	3000 N
Holding force F1max in accordance with ISO 14119	6000 N	6000 N	6000 N
Weight	260 g	600 g	630 g

15 Order reference

15.1 System

Product type	Features		Order no.
PSEN ml s 1.1 unit	Mechanical safety gate system with guard locking, coded, for series connection	12-pin M12 connector	570 406
PSEN ml s 1.1 switch	Mechanical safety gate switch with guard locking, coded, for series connection	12-pin M12 connector	570 407
PSEN ml 1.1 actuator	Actuator, coded		570 480

15.2 Accessories

Installation accessories

Product type	Features	Order no.
PSEN ml escape release	Escape release stationary	570 460
PSEN ml escape release extension	Extension escape release stationary 25 mm	570 462
PSEN ml escape release cordset 1.5m	Escape release with push/pull cable 1.5 m	570 470
PSEN ml escape release cordset 2.0m	Escape release with push/pull cable 2 m	570 471
PSEN ml escape release cordset 2.5m	Escape release external with push/pull cable 2.5 m	570 472
PSEN ml escape release cordset 3.0m	Escape release with push/pull cable 3.0 m	570 473
PSEN ml escape release cordset 3.5m	Escape release with push/pull cable 3.5 m	570 474
PSEN ml escape release cordset 4.0m	Escape release with push/pull cable 4 m	570 475
PSEN ml mounting plate	Mounting plate for installing the safety switch, with 4 hexagonal socket head screws and 1 tamper-proof pan head locking screw, M5x40	570 490
PSEN ml bracket sliding door	Mounting bracket for installing the actuator on a sliding gate, with 2 hexagonal socket head screws and 1 tamper-proof pan head locking screw, M5x16	570 492
PSEN ml bracket swinging door 70	Mounting bracket for installing the actuator on a swing gate, with 2 hexagonal socket head screws and 1 tamper-proof pan head locking screw, M5x12. Height: 70 mm.	570 493

Product type	Features	Order no.
PSEN ml bracket swinging door 80	Mounting bracket for installing the actuator on a swing gate, with 2 hexagonal socket head screws and 1 tamper-proof pan head locking screw, M5x12. Height: 80 mm.	570 494
PSEN ml door handle sliding door	Mounting bracket with handle unit for installing the actuator on a sliding gate, with 2 hexagonal socket head screws and 1 tamper-proof pan head locking screw, M5x16.	570 495
PSEN ml door handle swinging door 70	Mounting bracket with handle unit for installing the actuator on a swing gate, with 2 hexagonal socket head screws and 1 tamper-proof pan head locking screw, M5x12. Height: 70 mm.	570 496
PSEN ml door handle swinging door 80	Mounting bracket with handle unit for installing the actuator on a swing gate, with 2 hexagonal socket head screws and 1 tamper-proof pan head locking screw, M5x12. Height: 80 mm.	570 497
PSEN screw set bracket swinging door	Screw sets for attaching the mounting bracket to a swing gate	570 498
PSEN screw set bracket sliding door	Screw sets for attaching the mounting bracket to a sliding gate	570 499

Cable

Product type	Features	Connector X1	Connector X2	Connector X3	Order no.
PSEN cable axial M12 8-pole 3m	3 m	M12, 8-pin female connector, straight			540 319
PSEN cable axial M12 8-pole 5m	5 m	M12, 8-pin female connector, straight			540 320
PSEN cable axial M12 8-pole 10m	10 m	M12, 8-pin female connector, straight			540 321
PSEN cable M12-8sf, 20m	20 m	M12, 8-pin female connector, straight			540 333
PSEN cable axial M12 8-pole 30m	30 m	M12, 8-pin female connector, straight			540 326
PSEN cable M12-8sf M12-8sm, 0.5m	0.5 m	M12, 8-pin female connector, straight	M12, 8-pin male connector, straight		540 345
PSEN cable M12-8sf M12-8sm, 1m	1 m	M12, 8-pin female connector, straight	M12, 8-pin male connector, straight		540 346
PSEN cable M12-8sf M12-8sm, 1.5m	1.5 m	M12, 8-pin female connector, straight	M12, 8-pin male connector, straight		540 347
PSEN cable M12-8sf M12-8sm, 2m	2 m	M12, 8-pin female connector, straight	M12, 8-pin male connector, straight		540 340

Product type	Features	Connector X1	Connector X2	Connector X3	Order no.
PSEN cable M12-8sf M12-8sm, 5m	5 m	M12, 8-pin fe- male con- nector, straight	M12, 8-pin male con- nector, straight		540 341
PSEN cable M12-8sf M12-8sm, 10m	10 m	M12, 8-pin fe- male con- nector, straight	M12, 8-pin male con- nector, straight		540 342
PSEN cable M12-8sf M12-8sm, 20m	20 m	M12, 8-pin fe- male con- nector, straight	M12, 8-pin male con- nector, straight		540 343
PSEN cable M12-8sf M12-8sm, 30m	30 m	M12, 8-pin fe- male con- nector, straight	M12, 8-pin male con- nector, straight		540 344
PSEN cable M12-12sf 2m	2 m	M12, 12-pin fe- male con- nector, straight			570 350
PSEN cable M12-12sf 3m	3 m	M12, 12-pin fe- male con- nector, straight			570 351
PSEN cable M12-12sf 5m	5 m	M12, 12-pin fe- male con- nector, straight			570 352
PSEN cable M12-12sf 10m	10 m	M12, 12-pin fe- male con- nector, straight			570 353
PSEN cable M12-12sf 20m	20 m	M12, 12-pin fe- male con- nector, straight			570 354
PSEN cable M12-12sf 30m	30 m	M12, 12-pin fe- male con- nector, straight			570 355
PSEN cable M12-12sf 50m	50 m	M12, 12-pin fe- male con- nector, straight			570 356
PSEN cable M12-12sf/ M12-12sm 1m	1 m	M12, 12-pin fe- male con- nector, straight	M12, 12-pin male con- nector, straight		570 357
PSEN cable M12-12sf/ M12-12sm 2m	2 m	M12, 12-pin fe- male con- nector, straight	M12, 12-pin male con- nector, straight		570 358
PSEN cable M12-12sf/ M12-12sm 3m	3 m	M12, 12-pin fe- male con- nector, straight	M12, 12-pin male con- nector, straight		570 359
PSEN cable M12-12sf/ M12-12sm 5m	5 m	M12, 12-pin fe- male con- nector, straight	M12, 12-pin male con- nector, straight		570 360
PSEN cable M12-12sf/ M12-12sm 10m	10 m	M12, 12-pin fe- male con- nector, straight	M12, 12-pin male con- nector, straight		570 361

Product type	Features	Connector X1	Connector X2	Connector X3	Order no.
PSEN cable M12-12sf/ M12-12sm 20m	20 m	M12, 12-pin female connector, straight	M12, 12-pin male connector, straight		570 362

Series connection

Product type	Features	Connector X1	Connector X2	Connector X3	Order no.
PSEN ml Y junction M12		M12, 8-pin male connector	M12, 8-pin female connector	M12, 12-pin female connector	570 486
PSEN ml end adapter		M12, 12-pin female connector	M12, 8-pin male connector		570 487
PSEN ml / PSENcs Y junction M12		M12, 8-pin female connector	M12, 8-pin male connector	M12, 8-pin female connector	570 489

16 Appendix

The following check list is intended as a guide to provide support during commissioning, re-commissioning and the prescribed regular testing of the PSEN ml s 1.1.

Note that the check list is not intended to replace the plant-specific safety analysis required for commissioning/recommissioning, nor the resulting inspections and actions.



INFORMATION

Commissioning, recommissioning and regular inspection may only be carried out by qualified personnel.

We recommend that you keep the completed check list and store it with the machine documentation for reference.

Date	Action	Safety switch Number	Actuator Number	OK	Not OK	Notes	Signature

17 **EC declaration of conformity**

This product/these products meet the requirements of the directive 2006/42/EC for machinery of the European Parliament and of the Council. The complete EC Declaration of Conformity is available on the Internet at www.pilz.com/downloads.

Authorised representative: Norbert Fröhlich, Pilz GmbH & Co. KG, Felix-Wankel-Str. 2, 73760 Ostfildern, Germany

► Support

Technical support is available from Pilz round the clock.

Americas

Brazil

+55 11 97569-2804

Canada

+1 888-315-PILZ (315-7459)

Mexico

+52 55 5572 1300

USA (toll-free)

+1 877-PILZUSA (745-9872)

Asia

China

+86 21 60880878-216

Japan

+81 45 471-2281

South Korea

+82 31 450 0680

Australia

+61 3 95600621

Europe

Austria

+43 1 7986263-0

Belgium, Luxembourg

+32 9 3217575

France

+33 3 88104000

Germany

+49 711 3409-444

Ireland

+353 21 4804983

Italy, Malta

+39 0362 1826711

Scandinavia

+45 74436332

Spain

+34 938497433

Switzerland

+41 62 88979-30

The Netherlands

+31 347 320477

Turkey

+90 216 5775552

United Kingdom

+44 1536 462203

You can reach our international hotline on:

+49 711 3409-444

support@pilz.com

Pilz develops environmentally-friendly products using ecological materials and energy-saving technologies. Offices and production facilities are ecologically designed, environmentally-aware and energy-saving. So Pilz offers sustainability, plus the security of using energy-efficient products and environmentally-friendly solutions.

Energy saving by Pilz



CMSE®, InduraNET p®, PAS4000®, PASscal®, PASconfig®, Pilz®, PIT®, PLID®, PMCPirotego®, PMCiendo®, PMD®, PMI®, PNOZ®, Pirmo®, PSEN®, PSENi®, PSS®, PVIS®, SafetyBUS SafetyEYE®, SafetyNET p®, THE SPIRIT OF SAFETY® are registered and protected trademarks of Pilz GmbH & Co. KG in some countries. We would point out that product features mentioned in the details stated in this document, depending on the status at the time of publication and the scope of the equipment. We accept no responsibility for the validity, accuracy and entirety of the text and graphics presented in this information. Please contact our Technical Support if you have any questions.

Pilz GmbH & Co. KG
Felix-Wankel-Straße 2
73760 Ostfildern, Germany
Tel.: +49 711 3409-0
Fax: +49 711 3409-133
info@pilz.com
www.pilz.com

PILZ
THE SPIRIT OF SAFETY