



# UTX3K ULTRA

## INSTRUCTION MANUAL

PINEAPPLE TECHNOLOGY, INC



---

<b>Section I --- SAFETY NOTICES</b> .....	2
** READ THIS SECTION BEFORE INSTALLATION **	
<b>Section II --- TRANSMITTER SPECIFICATIONS</b> .....	3
<b>Section III --- TRANSMITTER INSTALLATION</b> .....	5
<b>Section IV --- TRANSMITTER TURN-ON</b> .....	7
<b>Section V --- THEORY OF OPERATION</b> .....	8
A. Introduction .....	8
B. ACDIS2 AC Main Distribution .....	8
C. AC2008 Power Supply .....	8
D. PAS4 and ADP500 Performance Monitor .....	9
E. RC8 Remote Monitor and Control W/ABS .....	10
F. MA5000 Modulator .....	11
G. UDR100AC Driver .....	11
H. US200-4 4-Way Splitter .....	11
I. MFA2PA Dual Power Amplifier .....	11
J. UC3KW4NDC Combiner/ Directional Coupler.....	12
K. BPU3KW Bandpass Filter .....	12
<b>SECTION VI --- SCHEMATIC AND PARTS LISTS</b> .....	
A. UTX3K ULTRA .....	13
B. ACDIS2 AC Main Distribution .....	15
C. UDR100AC Driver .....	17
D. MFA2PA Dual Power Amplifier .....	19
1. 1A0035 Status Board .....	21
2. PA1K 1KW Power Module .....	23
a. U500LDA 500 W Amplifier .....	23
b. U250LD 250 W Amplifier .....	23
c. 1A0025 Power Distribution Monitor .....	23
d. 1A0018 Gain and Phase Matching Network .....	23
E. UC200-4 4-Way Splitter .....	25
F. UC3KW4NDC 4-Way Combiner with Directional Coupler.....	27
G. BPU3KW Bandpass Filter .....	28
H. PAS4 and ADP500 Performance Monitor .....	29
<b>SECTION VII --- RECOMMENDED ROUTINE MAINTENANCE</b> .....	31
<b>SECTION VIII --- ADJUSTMENTS AND TUNING</b> .....	33
<b>SECTION IX --- PROBLEM SOLVING / TROUBLESHOOTING</b> .....	35
<b>SECTION X --- WARRANTY</b> .....	38
<b>SECTION XI --- EXTENDED WARRANTY</b> .....	39

# Section I

Safety  
Notices



I ---SAFETY NOTICES

**\*\* READ THIS SECTION BEFORE INSTALLATION \*\***

SEVERE ELECTRICAL SHOCK OR BURNS MAY OCCUR  
IF THIS EQUIPMENT IS USED IMPROPERLY.

---

---

NEVER WORK ON THIS EQUIPMENT ALONE. ALWAYS HAVE ANOTHER PERSON PRESENT  
WHILE WORKING ON ELECTRICAL CIRCUITS OR MOVING EQUIPMENT. COMMUNICATIONS  
TO EMERGENCY SERVICES SHOULD BE AVAILABLE AT ALL TIMES.

---

---

BEFORE CONNECTING THIS EQUIPMENT TO ANY AC ELECTRICAL SOURCE READ THE  
SECTION ON INSTALLATION. ALL ELECTRICAL WIRING FOR THIS EQUIPMENT MUST BE  
PERFORMED BY QUALIFIED ELECTRICIANS. ALL WIRING MUST BE COMPLIANT WITH  
LOCAL ELECTRICAL CODES.

---

---

POWER AMPLIFIERS AND SUPPLIES ARE HEAVY. TO INSTALL THIS EQUIPMENT IN RACKS  
USE TWO (2) PERSONS TO AVOID POSSIBLE INJURIES.

---

---

NEVER OPEN THE CABINET ENCLOSURE OR UNPLUG CABLES OR WIRES WHILE THIS  
EQUIPMENT IS OPERATING.

---

---

***ALL SERVICE WORK MUST BE PERFORMED BY QUALIFIED TECHNICIANS ONLY.  
IF ONE IS NOT AVAILABLE LOCALLY, CONTACT PINEAPPLE TECHNOLOGY, INC. FOR  
A LIST IN YOUR AREA.***

# Section II

## Transmitter Specifications



## II – UTX3K ULTRA SPECIFICATIONS

### OPERATING

Power Output .....	3 kW Peak Sync 150 Watts Aural
RF Output Impedance.....	50 ohms
Frequency Range.....	470 – 806 MHz
Frequency Stability.....	1 PPM or better
Harmonic and Spurious.....	-60 dB or better ref to P-sync
Power Consumption.....	12 kW maximum
AC Line Voltage.....	220 – 240 VAC Single Phase (Standard) 208 – 240 VAC 3 Phase (Optional)

### VIDEO PERFORMANCE

Visual Frequency Response.....	+/- 1 dB across the TV channel -1.25 MHz to 4.75 Mhz relative to visual carrier.
Differential Gain.....	< 7%
Differential Phase.....	< 10 degrees
ICPM.....	< 5 degrees
Low Frequency Linearity.....	< 15%
Group Delay.....	Meets FCC Part 73 Rule
Video Input Impedance.....	75 ohms
Video Input Level.....	1 volt p-p
Variation of Output Power.....	< 5%
Regulation of Output Power.....	< 5% typical
Video Signal to Noise Ratio.....	< 45 dB un-weighted



# Section III

## Transmitter Installation





### III -- TRANSMITTER INSTALLATION Page 1 of 2

To ensure long and reliable trouble-free service from the UTX3K ULTRA transmitter the following steps for installation are recommended:

1. **MECHANICAL INSTALLATION:** The UTX3K ULTRA was designed to be installed in a building protected from the weather. The building should have a hard-surface floor such as concrete with a moisture barrier. This barrier could be pressure-treated wood sub flooring which could be anchored to the concrete and to the transmitter to make the installation earthquake resistant.

Allow a minimum of three feet around the transmitter cabinet for service access. The top of the transmitter should be clear for three feet above to allow the air to exhaust from the transmitter.

Air flow thru the transmitter is approximately 2,000 CFM. Provisions for air inlet and exhaust from the room must allow air flow with minimal obstruction. In the event that the room temperature exceeds 35° Celsius (95° F), cooling air must be provided so that the room temperature will not exceed 35 degrees Celsius under worst case conditions.

Notice: This equipment is **HEAVY** and must be handled by professional movers with proper equipment. Any damage caused by the installers is not covered under warranty. Check to ensure that installing crews have proper insurance coverage.

2. **GROUNDING:** Transmitter grounding is **VERY IMPORTANT** and must be done correctly for safety and operational reasons. A typical installation may be done as follows:

Use a heavy gauge wire such as #2 AWG stranded copper or solid copper buss one (1) inch wide by 1/8 inch thick for connections. The bonding between the transmitter and the ground rods must be good quality and protected from corrosion. The ground wires should run over the floor and be connected to the ground rods located outside the building. The wire should not go thru the concrete floor but over and around it.

3. **AC WIRING:** Wiring to the house electrical sub-panel will be routed to the AC terminal block mounted in the back of the rack.

#### 220 VAC Single Phase Standard Power Connections

Connections to the AC Main should be made as follows:

- RED and BLACK are connected to the 220 VAC.
- WHITE WIRE is connected to NEUTRAL.
- GREEN WIRE is connected to SAFETY GROUND.

#### 208 VAC 3 Phase Optional Power Connections

Connections to the AC Main should be made as follows:

- RED, BLACK AND ORANGE are connected to the 208 VAC 3-PHASE.
- WHITE WIRE is connected to the NEUTRAL.
- GREEN WIRE is connected to the SAFETY GROUND.

**NOTICE: All wiring of this type must be done by a QUALIFIED ELECTRICIAN and must conform to LOCAL and NATIONAL wiring CODES.**

Consult with your electrician to ensure that the proper breaker size is selected for the main circuit.



**III -- TRANSMITTER INSTALLATION Page 2 of 2**

4. **ANTENNA CONNECTION:** The transmitter is equipped with 1 5/8" EIA flange connectors located at the top of the rack. Conditions vary from site to site so some engineering may be required to ensure that the antenna is receiving the correct amount of power to comply with FCC licenses and to ensure safety from lightning, etc.

# Section IV

Transmitter  
Turn-On



#### IV --- TRANSMITTER TURN-ON PROCEDURE

Before applying AC Power to the transmitter for initial turn-on and check out, the installation should be approved by a qualified broadcast engineer. The turn-on procedure that follows is recommended by Pineapple Technology, Inc. engineering staff:

1. Check transmitter load or antenna for proper installation and connection to the transmitter.
2. Open the transmitter and inspect all cables and wires for loose connections or broken wires in the rack assembly.
3. Check for damage to the equipment mounted in the rack.
4. Check all AC breakers and on/off switched to ensure that they are all in the **OFF** position.
5. Verify AC switch on the UDR100AC is in the **OFF** position.
6. Locate the output level adjustment on the MA1000 Modulator and turn the level down to minimum or CCW (Note: This is a multi-turn potentiometer)
7. Turn-on Main AC breaker located in the house service sub-panel.
8. The MA1000 Modulator should come on at this point. Verify the correct channel number appears on the modulator front panel and the frequency lock LED is lighted.
9. Turn-on the AC Main breaker located on the ACDIS2 Power Distribution panel. A light should come on indicating power is on.
10. Turn-on the AC Switch located on the front of the ADP500. The indicating lights should be on and ready for operation.
11. Turn-on the AUX (FAN) Breaker(s) located on the ACDIS2 front panel. The PA fans and rack exhaust fans should come on.
12. Turn-on the AC Power breakers located on the front panel of the ACDIS2. Check the AC2009 power modules, three (3) each, to see if the green lights are lighted indicating normal operation.
13. Using the ADP500 and PAS4, check the idling currents on each PA to ensure that the currents are in the correct range. Typical range is 1.5 to 2.5 amps. See ADP500 Operating Section for details.

NOTICE: The Modulator has been set at the factory so that the output power indication on the ADP500 will show 100% or 2 KW p-sync power level. It is important to read the instruction manual supplied with the modulator to locate key adjustment devices on the front panel. The output level adjustment will be necessary for the next step in the turn-on procedure.

14. Turn-on the power switch located on the UDR100AC front panel.
15. Apply a video signal (1 volt P-P) to the video input terminal.
16. Verify the display rocker switch on the MA5000 Modulator is in the VIDEO or down position and three (3) green bars appear on the display bar graph.
17. Slowly increase the output level adjustment while watching the **RF Output** level on the ADP500 meter until it reads to 50%.
18. Using the ADP500 reflected power indication, check the LOAD reflected power. This should be less than 5% reflected.
19. Return to the PA current readings on the ADP500 to verify that all the currents are approximately the same.
20. With successful performance to Step 17, the transmitter output power can be increased using the output level adjustment on the modulator to achieve 100%. The aural power can be added at this time not exceeding 10% of output p-sync power as indicated on the ADP500.

# Section V

Theory  
of  
Operation



## V --- THEORY OF OPERATION (Page 1 of 5)

### A. INTRODUCTION

The UTX3K ULTRA transmitter was designed to meet or exceed all FCC applicable specifications for TV broadcast equipment. Special attention was given to the selection of sub-assemblies and components to achieve maximum reliability and minimum down time. The construction of the UTX3K ULTRA is BASIC and MODULAR with most components field replaceable. Special emphasis was placed on "KEEPING IT SIMPLE" and returning to more traditional transmitter layouts and instrumentation.

This transmitter was designed for Analog (NTSC) transmission with provisions and options available to convert to Digital Service at a later date if necessary.

Refer to the UTX3K ULTRA block diagram in for an overview of the transmitter architecture. This will give the technician basic information needed to understand the operation of the transmitter and the function of each subassembly.

SEE SECTION VI.A FOR PARTS LIST AND BLOCK DIAGRAM.

### B. ACDIS2 AC & DC DISTRIBUTION

The ACDIS2 is the primary AC power inlet module. The UTX3K ULTRA transmitter was designed to accept 220 to 240 VAC Single Phase (Standard) using a four (4) wire connection (208 3 Ø Optional). The four wires are:

<u>Standard</u>	<u>Optional</u>
--- 2 wires for 220 -240 VAC Single Phase	--- 3 wires for 208 - 240 VAC 3 Phase
--- 1 wire for neutral connection	--- 1 wire for neutral connection
--- 1 wire for safety ground connection	--- 1 wire for safety ground connection

**CAUTION:** Connection to the AC Primary source must be made using all four wires listed above. Follow the wiring instruction given in TRANSMITTER INSTALLATION Section III.3. If not followed, severe damage to the transmitter and, or, electrical shock could result.

The ACDIS2 performs the following functions:

1. Provides a primary AC power breaker point to shutdown the transmitter
2. Provides 220 (208 3Ø) VAC power to each of the three 2 KW DC power supplies with individual breaker points for added safety.
3. Provides 110 VAC circuits for Modulator, ADP500, ABS (as necessary) and AUX Power where needed.
4. Analog metering is provided to monitor the Power Supply voltage and current being applied to the RF Amplifier states.
5. Power supply current sharing test points are provided for checking current sharing between power supply modules.

SEE SECTION VI.B FOR SCHEMATIC AND PARTS LIST

### C. AC2008 2KW POWER SUPPLY MODULE

The UTX3K ULTRA transmitter is designed with over 6 KW of DC power. To achieve this level, the power supply in each transmitter rack is made up of three (3) TWRI6004 (PTI Part # AC2008) power modules mounted into one (1) main frame assembly (PTI Part # AC2009) which are capable of managing three (3) 2 KW modules each.



(CONTINUED) Page 2 of 5

The power modules are "HOT PLUGGABLE" and can be removed or installed without turning off the transmitter.

Each power supply module has OVER VOLTAGE, OVER CURRENT AND OVER TEMPERATURE protection as well as a fault signal in the event of a failure.

REFER TO MANUFACTURER'S MANUAL FOR MODEL # TWRI6004 PROVIDED WITH THE UTX3K ULTRA.

D. ADP500 AND PAS4 PERFORMANCE MONITOR

The ADP500 AND PAS4 Performance Monitor provides the following functions:

1. Monitors FORWARD AND REFLECTED POWER to the antenna and presents it as a percentage of power rating. The transmitter comes set to 100% P-Sync power based on the ratings of the transmitter.
2. Monitors Aural Power as a percentage of P-Sync rating (5% typical).
3. Provides a HIGH ANTENNA VSWR MONITOR in the event of an antenna or coax failure where the reflected power exceeds 25% the transmitter will shut down. The front panel LED will change from green to red in case of a fault.
4. Provides current monitoring of all the pallets used in the three (3) PA1K power amplifier assemblies. The current levels can be read directly from the multi-meter on the front panel. Individual pallets are selectable on the ADP500 and the PA assemblies are selected using the PAS4. In normal operation, a PA FAULT is indicated by going from green to read. RED indicates that the current level is below 500 ma and a transistor may have failed. To read the actual current, select the appropriate PA Bank using the PAS4. The ADP500 will display status of each pallet in that PA. The multi-meter will read the actual current.
5. A PA INHIBIT switch is provided for failure diagnostic purposes. When activated, this switch allows the technician to monitor the bias currents for each pallet. These readings were recorded at the factory and are found on the Transmitter Test Report, DC Test Report Section. This is the best way to troubleshoot possible transistor problems. When in the PA INHIBIT mode, the RF PWR OFF LED will change from green to red indicating that the "SHUTDOWN LINE" is at TTL 0 state and the output power has been reduced to near zero.
6. An RF MONITOR port (BNC) is available to connect a spectrum analyzer for monitoring the output signal.
7. METER SELECTION SWITCHES

The PAS4 is used to select the appropriate PA module (PA1K) for performance display on the ADP500. PA designations are PA1 starting from the top row left, PA2 in the top row right, with PA3 and 4 located on the bottom row left to right.

The rotary switch on the ADP500 is the detail selector for the multi-meter. The various positions are defined as follows:

- PA1 thru PA5..... Reads PA Pallet currents as selected
  - Typical reading in INHIBIT MODE 1.5 to 2.5 A
  - Typical reading SMPTE BARS 5-7 A for PA1 thru PA4 with normal picture
  - Typical reading SMPTE BARS 2-3 A for PA5 with normal picture



(CONTINUED) Page 3 of 5

7. METER SELECTION SWITCHES (Continued)

- PA6..... No Connection
- PS VOLTS..... Reads DC voltage applied to PA stages  
Typical reading would be +30 to 33 VDC
- P FWRD..... Reads PA output power in P-Sync percentage of rating  
Full power reading would be 100%
- P RFLD..... Reads PA output power being returned from the load and  
displayed as a percentage of forward power. Typical  
reading would be < 5% indicated.
- P AURAL..... Reads the AURAL POWER component as a percentage  
of forward power. Typical reading would be 5%
- AUX 1 & AUX 2..... Not used in this configuration.

REFER TO SECTION VI.H FOR SCHEMATICS AND PARTS LIST

E. RC8 REMOTE MONITOR AND CONTROL WITH ABS

This equipment is **OPTIONAL** and can be used to satisfy FCC remote control requirements.

The Remote Monitor is used to monitor the operational status of the transmitter and will allow the operator to turn RF on or off and adjust power levels remotely. The following items are monitored or controlled:

1. Transmitter on/off function
2. Power output level monitor and adjust
3. AC Line Voltage status - With ABS you can be notified if there is a power failure at the site.
4. Various other custom options are available. Specify these at the time the transmitter is purchased and they will be included if possible.

Remote monitoring requires a phone line connection. Information can be accessed via a PC Terminal or via an optional "VOICE COMMAND LINE".

The Auxiliary power unit requires a battery connection. A common car battery (12 VDC) can be used with a charger as an ABS. This will run the Monitor and provide access to transmitter status for several hours.

A manual for this equipment is provided by the Manufacturer and is included in the UTX3K ULTRA package shipped with the transmitter. **The manual is only included if this option was purchased for delivery with the transmitter.**

REFER TO INSTRUCTION MANUAL PROVIDED WITH THIS PACKAGE.





(CONTINUED) Page 4 of 5

#### F. MA5000 MODULATOR

The heart of any TV Transmitter is the MODULATOR. This equipment receives the video and audio signals as well as any control signals needed. The base band signals are converted to RF with an output on the desired operating channel.

Detail operation of the Modulator with schematics and parts list are provided by the equipment manufacturer and included in the UTX3K ULTRA package shipped with the transmitter.

REFER TO INSTRUCTION MANUAL PROVIDED WITH THIS PACKAGE.

#### G. UDR100AC 100 WATT DRIVER AMPLIFIER

The RF output from the MA5000 modulator is accepted by the UDR100AC DRIVER AMPLIFIER. This amplifier increases the drive level to that required for each of the PA1K power amplifiers to make rated power. The UDR100AC is powered by 110 VAC.

#### H. US200-4 4-WAY SPLITTER

The US200-4 4-Way phase and gain splitter receives the output from the UDR100AC Driver Amplifier and splits it into 3 parts with phase and power levels equal. This unit is an isolated in-phase splitter and will provide some isolation in the event one PA fails.

SEE SECTION VI.F FOR PARTS LIST

#### I. MFA2PA POWER AMPLIFIER HOUSING

The MFA2PA is the main RF Power Amplifier housing which accommodates two (2) PA1K Amplifiers. The housing includes the following:

- 2 each 330 CFM cooling fans
- 2 each Air filter assemblies
- 2 each Front panel status PC boards
- 1 each Main chassis
- 2 each Mechanical slide assemblies
- 1 each AC Filtered inlet for cooling fans

SEE SECTION VI.D FOR SCHEMATICS AND PARTS LIST

#### I-1. PA1K POWER AMPLIFIER

The PA1K is the main RF Power Amplifier Assembly used in the UTX3K ULTRA. Each amplifier assembly is made up of one (1) U250LD power pallet and two (2) U500LDA power pallets. These amplifiers are operated in Class A/AB or sometimes referred to as "HARD AB". This refers to the bias levels to achieve best linearity.



(CONTINUED) Page 5 of 5

Each PA1K amplifier assembly includes the following:

- 1 each U250LD power pallets
- 2 each U500LDA power pallets
- 1 each Phase and gain matching circuit
- 1 each 2-Way in-phase splitter
- 1 each 2-Way in-phase combiner
- 1 each Circulator
- 1 each Power distribution module (1A0025)
- 2 each Thermal sensors
- 1 each Remote monitor port (DB9)
- 1 each Front panel status port (Molex)
- 1 each Filtered DC input port
- 1 each Type N Panel mounted RF Input port
- 1 each DIN 7/16 Panel mounted RF Output port

SEE SECTION VI.E. FOR SCHEMATICS AND PARTS LIST

#### J. UC3KW4NDC COMBINER/ DIRECTIONAL COUPLER

The UC3KW4NDC is a 4-Way in-phase combiner. The combiner is specifically designed for the channel designated transmitter frequency. This is a closed unit and cannot be serviced.

SEE SECTION VI.G. FOR PARTS LIST

#### K. BPU3K UHF BAND PASS FILTER

This Band Pass filter was designed to meet FCC Certification requirements with minimum loss of RF Power. The BPU750N comes tuned and tested to the operating frequency of the transmitter and should not be adjusted without proper equipment. Replacement filters are available as P/N BPUKW UHF (+CHANNEL NUMBER).

# Section VI

Schematic  
and  
Parts List



**A. UTX3K ULTRA Parts Assy**

Item	Qty	Type	P/N	Title	Detail
Top		CAT	UTX3K ULTRA	UHF TV XMTR 3 KW P-SYNC	STD 19 IN RACK 6 FT WITH 1 5/8 FLG
1	1	PS	MFR40RU	40 RU ASSEMBLED RACK	BLACK CONTEMPRA 2 WELDED
3	2	PL	MFA2PA	2KW MAIN FRAME W/U500LD AMPS	UHF/VHF ASSEMBLIES
4	1	PS	AC8100	AC WIREMOLD 120 VAC 19 IN RACK MTG	1 X 4 OUTLETS 6 FT CORD
5	1	PS	AC8220	AC WIRE MOLD 220 VAC	19 IN RACK MT
6	1	CAT	ADP500	DISPLAY PANEL, ANALOG	SEL SW AND METER
7	1	PL	ACDIS2	AC & DC DISTRIBUTION	UTX2KWA TRANSMITTERS
8	1	CAT	PAS4	PA SEL SW FOR ADP500	4 POSITIONS W/1 OUTPUT
9	4	PS	1A7052	CABLE ASSEMBLY RG-223	BNC-M TO N-M 52 INCHES LONG
10	4	PS	PAC0005	DB9 MALE TO MALE 6 FT LONG	PA MONITOR CABLE
11	1	PL	1A6004	DC CABLE SET 5KW	HIGH CURRENT ASSEMBLY
12	1	CAT	UDR100AC	UHF DRIVER AMP 100W W/AC SUPPLY	U250LD AND UDR100 AMPS
13	1	PS	MFR44RU-BB	GROUNDING BAR CU	MIDDLE ATLANTIC BB-44-1
14	35	PS	INHOUSE_LABOR	PTI LABOR	LOADED
15	20	PS	INHOUSE-ENG TEST	ENG TESTING AND FIXIT	LOADED
16	4	PL	1A7065	CABLE ASSEMBLY LDF4-50	UTX SERIES XMTR 7/16 DIN TO N M
18	1	PS	MA1000	M369 CADCO MODULATOR	MODIFIED TO PTI SPECS
19	1	PL	AC2009	6KW 3EA PWR SUPPLY MAIN FRAME	UNIPOWER RRS2U
20	3	PS	AC2008	2 KW 31 VDC PWR SUPPLY	UNI-PWR TRS6000-406
22	8	PS	MF9283	EQUIPMENT SUPPORT	14 GA GAL-XC (LEFT & RIGHT)
23	1	CAT	US200-4	UHF 4-WAY SPLITTER	TYPE N 500 WATT
24	1	PS	UC3KW4NDC	3 KW N-WAY COMB W/COUPLE	1 5/8 FLG W/N INPUTS
25	1	PS	BPU3KW	BP FITER 3 KW BAND IV	COM-TECH FC4E110C
26	0.5	PS	MFR44RU-HP5	10-32 MTG SCREWS	BLACK
27	1	PS	851026	EXHAUSE	MULTIFAN VOSTERMANS 4VF1042A
28	2	PS	MF9555A	EXHAUST FAN	OUTLET SIDE PANEL
29	1	PS	MF9556A	EXHAUST FAN	FINGER GUARD

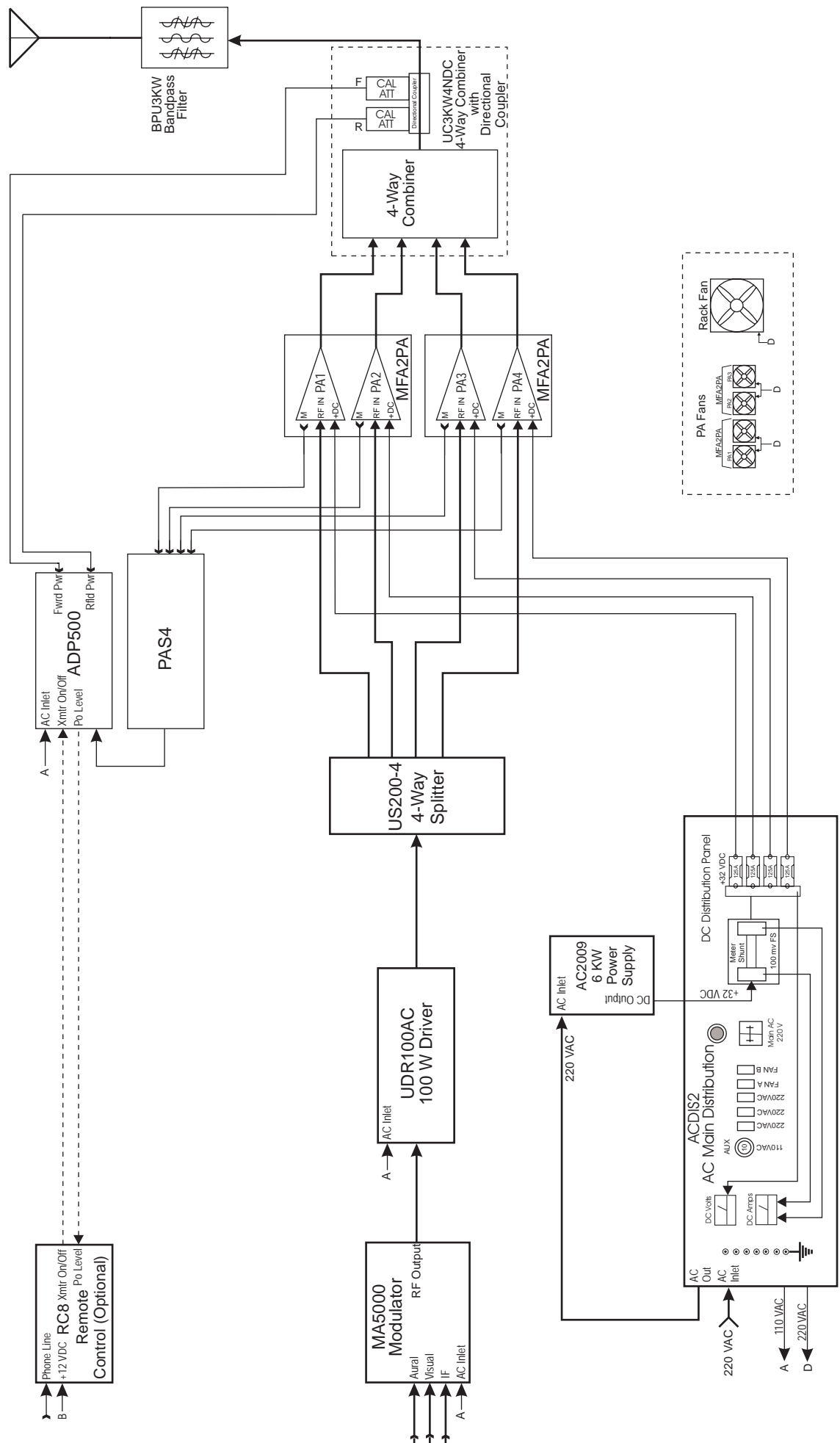

Pineapple Technology, Inc.  
 Rocklin, CA  
 UTX3K ULTRA  
 BLOCK DIAGRAM

SIZE	FORM NO.	DATE	REV
B			3
SCALE	FIT	SHEET	1 of 1



**B. ACDIS2 Assy Tree**

Item	Qty	Type	P/N	Title	Detail
Top		PL	ACDIS2	AC & DC DISTRIBUTION	UTX2KWA TRANSMITTERS
1	1	PS	660110	DC PANEL METER 50 V FS	HOYT MODEL 3115 1-1/2 ANA PANEL
2	1	PS	660113	DC AMP METER 300 A FS	HOYT 3115 100mv FS
3	1	PS	670300	SHUNT, METER 100 mv FS	Lightweight shunt, 100 Millivolt, 300 amp.
4	1	PS	AC3110	AC CKT BREAKER	115 VAC 10 AMPS RS TYPE
5	1	PS	AC8000	AC POWER DISTRIBUTION BLOCK	3 POLE 840 A 600 VAC
6	1	PS	AC5105	AC PANEL MTG OUTLET	4 POSITION "GANGED" 15A 115VAC
8	4	PS	AC4111	AC POWER PLUG 220AC 16A	POWER INLET SCHURTER 4300.0922
9	2	PS	480461	MOLEX CRIMP TERM PLUG	PLUG HOUSING 6 POLE
10	4	PS	480462	MOLEX CAP STRAIN RELIEF	ACDIS SUBASSEMBLIES
11	2	PS	480460	MOLEX CRIMP TERM 6 POLE	CAP HOUSING PANEL MTG
12	12	PS	480463	MOLEX PIN CONTACTS LRG	CONN PIN 14-20 AWG TIN CRIMP
13	12	PS	480464	MOLEX SOCKET CONTACTS	CONN SOCKET 14-20 AWG TIN CRIMP
14	1	PS	480465	MOLEX PLUG HOUSING	9 POLE MATE-LOC
15	1	PS	480466	MOLEX CAP HOUSING	9 POLE
16	2	PS	480467	MOLEX STRAIN RELIEFS	9 POLE
17	4	PS	471380	FUSE FAST ACTING 80 AMP	USE WITH LFFB0001 HOLDER
18	4	PS	460190	FUSE HOLDER 400A	LITTELFUSE LFFB001
19	5	PS	AC3315	AC CKT BKR ELUMINATED	U600LPA 220 15 A 2 POLE
20	1	PS	MF9312	ACDIS MAIN CHASSIS	AL 090 MATERIAL ALODYNE/W SILK
21	1	PS	MF9313	ACDIS MAIN COVER	1 & 2 KW 090 AL ALODYNE
23	1	PS	MF9311	PLATE, FRONT ACDIS2	
24	1	PS	AC3250	AC CKT BRKR	50 AMP 2-POLE 220V
25	2	PS	453000	HW, TIP JACK	RED, Insulated standard TIP JACK
26	2	PS	453001	HW TIP JACK	WHITE, Insulated standard TIP JACK
27	1	PS	453002	HW, TIP JACK	BLACK, Insulated standard TIP JACK
28	2	PS	453003	HW, TIP JACK	BLUE, Insulated Standard TIP JACK
29	1	PS	AC4302	AC CORD GRIP	0.98 OD CABLE 1.3 HOLE MTG

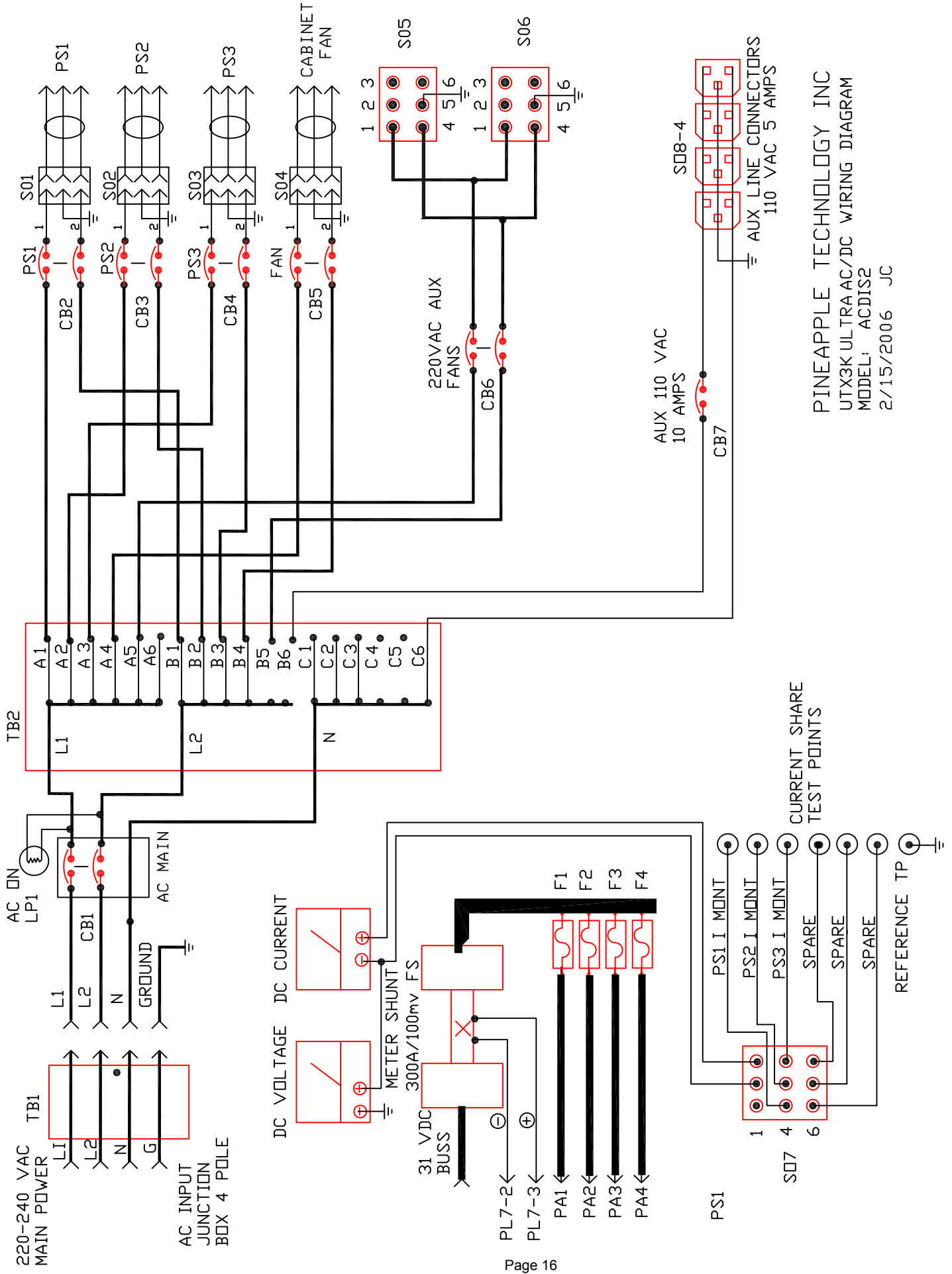

PINEAPPLE TECHNOLOGY INC  
 UTX3K ULTRA AC/DC WIRING DIAGRAM  
 MODEL: ACDIS2  
 2/15/2006 JC



**C. UDR100AC Assy Tree**

Item	Qty	Type	P/N	Title	Detail
Top		CAT	UDR100AC	UHF DRIVER AMP 100W W/AC SUPPLY	U250LD AND UDR100 AMPS
1	1	CAT	U250LD	UHF TV 250 W P-SYNC PALLET	470-810 MHz ZINGER COMBINER
2	1	CAT	UDR25A	DRIVER, 25W LINEAR 470-815 MHz	LD MOS DUAL PACKS PALLET MTG
3	1	PS	MF9337B	PANEL, FRONT	DRV100DC
4	1	PS	MF9338F	CHASSIS	DRV100-3
5	1	PS	MF9339B	DIVIDER AIR FLOW	DRV100DC
6	1	PS	MF9340B	TOP COVER DRV100DC	
7	1	PS	MF9341	DRV100 HEAT SINK	ALL DRV TYPES
8	2	PS	851005	FAN DC 24 V 80X25mm	COMAIR-ROTRON
9	2	PS	990201	FILTER & FINGER GUARD	80X25mm FAN 30 PPI
10	1	PS	631001	INDICATOR LAMP LED	GREEN 24 VDC 1/2 IN MTG HOLE
11	1	PS	484001	SW, ON/OFF ROCKER AC	CW IND. NAA-211-B121-00
12	1	PS	AC1003	FILTER, AC LINE	110/220 AC PLUG
13	1	PS	AC3110	AC CKT BREAKER	115 VAC 10 AMPS RS TYPE
14	1	PS	451004	HW TER BLOCK	#6 2X6 ROW
15	5	PS	451010	TERM BLOCK JUMPERS	2 POLE
16	1	PS	AC2010	DC POWER SUPPLY 115/220 VAC	320 WATTS 27-31 VDC
17	2	PS	CC316-NPF-PT-21	CABLE ASSEMBLY RG316/	1 N-FM PANEL MT WITH PIGTAIL
18	1	PS	481100	CON 9 P D-SUB MALE	MALE 9P SOLDER CUP
19	1	PS	140010	RES 2W 10 OHM	10 OHM
20	1	PS	140012	RES AXIAL TH 2 WATT	75 OHM METAL OXIDE



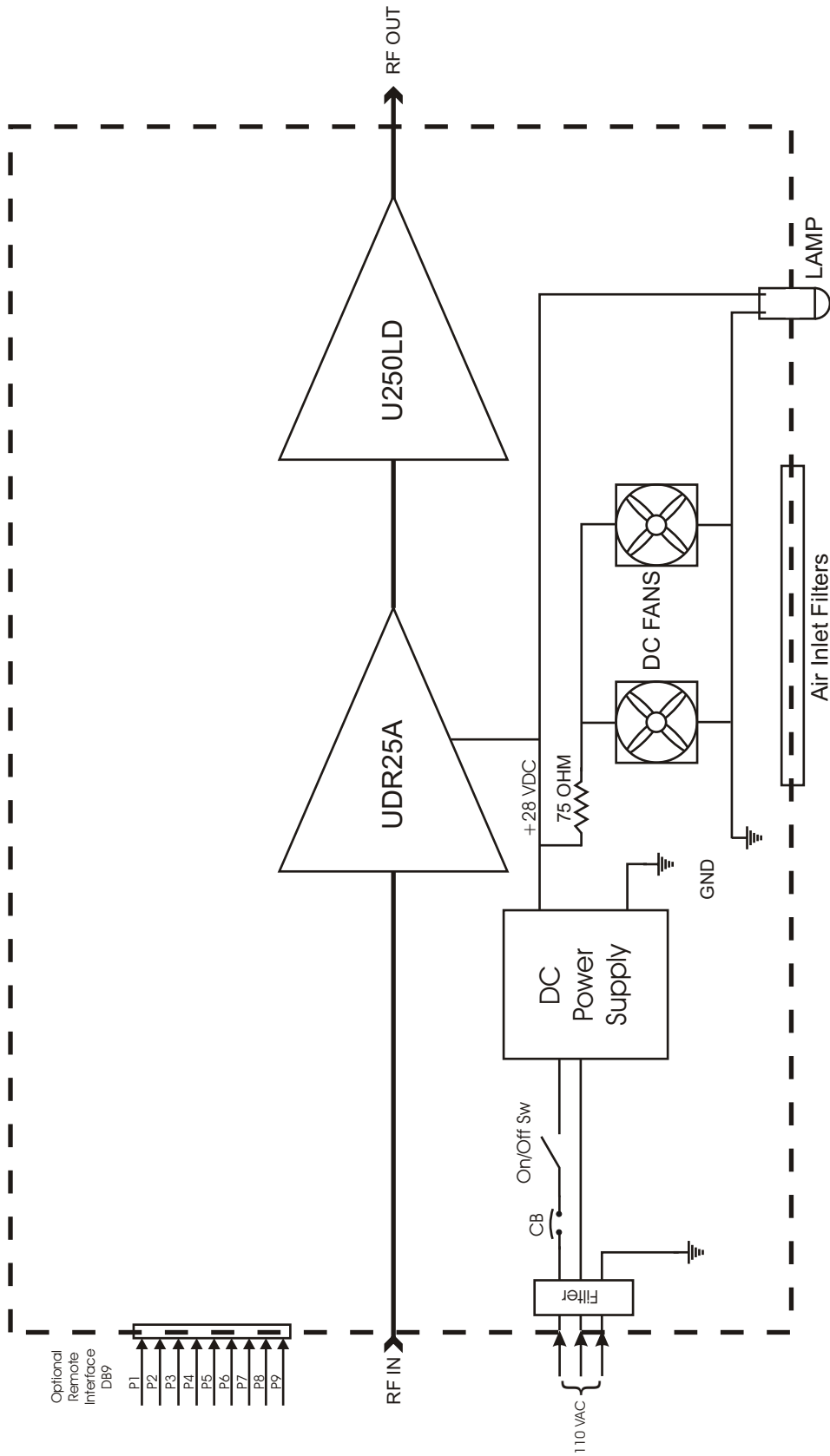

Pineapple Technology, Inc. Rocklin, CA			
UDR100AC AMP/DRIVER BLOCK DIAGRAM			
SIZE	FSCM/NOJ	DWG/NOJ	REVJ
SCALE	1:1	SHEET	1 of 1



**D. MFA2PA POWER AMPLIFIER -- PARTS LIST**

Item	Qty	Type	P/N	Title	Detail
Top		PL	MFA2PA	2KW MAIN FRAME W/U500LD AM	UHF/VHF ASSEMBLIES
1	1	PS	MF9100E	MAIN CHASSIS	MFA1KW
2	1	PS	MF9101D	DIVIDER, PLENUM	MFA1KW
3	1	PS	MF9102C	DIVIDER, FAN	MFA1KW
5	1	PS	MF9104B	COVER, TOP	MFA1KW
10	4	PS	MF9139	SLED GUIDE	U600LP & MFA1KW
11	1	PS	MF9123D	FRONT PANEL, PAINTED	MFA1KW
14	2	PS	990199	FILTER, AIR DRY	FF-5 MFA/PS FP
16	2	PS	MF9127	MTG BRACKET, MOLEX FEMALE	MFA1KW
17	6	PS	480472	MOLEX CRIMP TERM MFA1KW	MOLEX MFG 39-00-0041
18	2	PS	480400	MOLEX PLUG 6 TERM MFA1KW	MOLEX 15-06-0065 MINI-FIT BMI
19	2	PS	460150	FUSE HOLDER PANEL MTG	3AG TYPE QC CON
20	2	PL	1A0035	PA STATUS BOARD	PC9061H
22	4	PS	INHOUSE_LABOR	PTI LABOR	
24	2	PS	MF9308	FAN FINGER GUARD	MFA1KW & U600LPA
25	2	PS	MF9310	AC FAN INLET HOLDER	MFA1KW
27	2	PS	MF9258	BRACKET FILTER MTG PAINTED	U600LPA & MFA1KW
28	1	PS	MF9197B	DIVIDER PA	MFA1KW
29	2	PS	851025	FAN, AC 220 V	COMAIR ROTRON TN3A2
30	2	PS	AC5110	AC FAN PLUG & CORD	FEMALE PLUG 24 IN CORD
31	2	PS	451080	TERM BLOCK EU STYLE	4 POLE 12-24 GAGE
32	0.1	PS	H-TAPE_TFE	TEFLON TAPE, SLIDES	1 INCH X 56 INCHS
33	2	PL	PA1K	UHF 1KW PA ASSEMBLY U500LD	DIN OUTPUT W/CAPTOR FILTERS





**D. MFA2PA POWER AMPLIFIER**  
**1. 1A0035 STATUS BOARD PARTS LIST**

Item	Qty	Type	P/N	Title	Detail
Top		PL	1A0035	PA STATUS BOARD	PC9061H
1	2	PS	114330	RES ARRAY, SMT	330 OHMS
2	5	PS	115103	RES CHIP 0805	10K OHM SMT 0805
3	1	PS	115334	RES CHIP 0805	330 K OHM SMT
4	1	PS	115563	RES CHIP 0805	56K OHM 0805 SM
5	3	PS	115682	RES CHIP 0805	6.8 K OHM SMT
6	6	PS	21X005	CAP CHIP 0805	100NF 10% XTR 0805 CASE
7	1	PS	21X008	CHIP CAP 0805	10NF 50 V 0805 SM
8	1	PS	240109	CAP TH POLYPROPYLENE	3N3 600 WVDC .033UF
9	1	PS	240110	CAP TAN SMD	3.3 UFD 35 V
10	1	PS	240111	CAP TAN SMD	47 UF 10 V TAN
11	1	PS	241300	CAP RADIAL TH	330 UF 35 VDC
12	1	PS	241301	CAP RADIAL TH	680 UF 10 V ELECTROLYTIC
13	6	PS	27022N	FT CAP 22N SM	AVX OR MURRATA PART
14	1	PS	480500	CON MICRO-FIT HEADER 3.0	8 PIN PC MTG
15	1	PS	520230	SEMI DIODE SHOTTKEY	1.5 A 60 VDC D-64
16	1	PS	520275	SEMI, DIODE DUAL	SW CC 70V SOT-23
17	2	PS	530350	HEX SCHMITH TRIG	74HD14
18	1	PS	538150	IC SWITCHER SIMPLE	SO8 PAK
19	5	PS	630200	IND LED DUAL COLOR	RED/GREEN T1-3/4 CLR
20	8	PS	750001	FERRITE BEAD SMT	0805 EMI FERRITE BEAD
21	1	PS	830510	IND, W/W	82 UH .58A PWR SMD
22	1	PS	PC9061H	PA STAUS BRD	FR4 060 1/1 CBR
23	2	PS	115331	RES CHIP 0805	330 OHM SMT
24	1	PS	520120	SEMI ZENER	5.6 V MELF
25	1	PS	115683	RES CHIP 0805	68K SM
26	0.2	PS	OS_AES_1A0025	OUTSIDE ASS'Y 1A0025	ASS'Y WORK
27	0.1	PS	INHOUSE_LABOR	PTI LABOR	
28	0.1	PS	INHOUSE-ENG TEST	ENG TESTING AND FIXIT	
29	1	PS	480510	RECEPTACLE	8 CKT RECEPT MOLEX
30	1	PS	115333	RES CHIP 0805	33K OHM SMT
31	1	PS	1155112	RES 0805 CASE	51.1 K OHM 1%

SECTION VI - SCHEMATICS AND PARTS

11

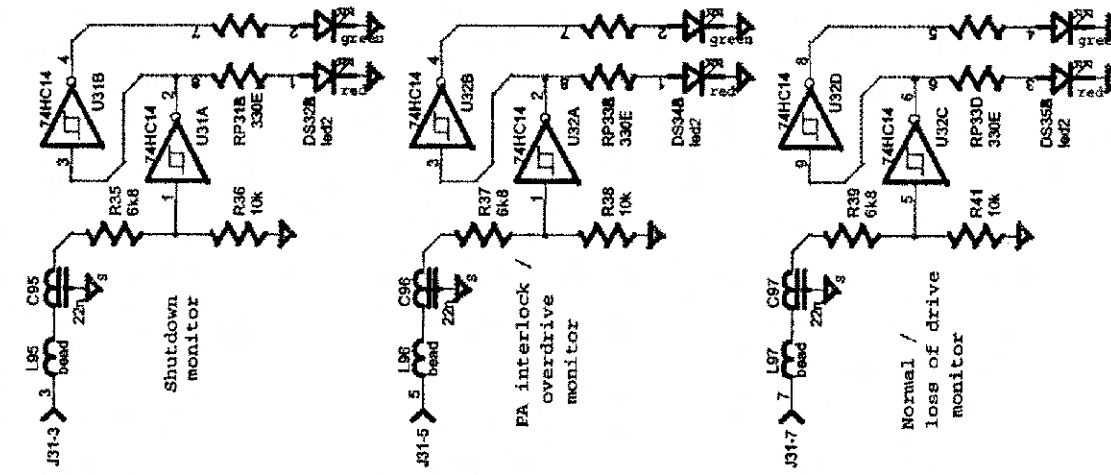
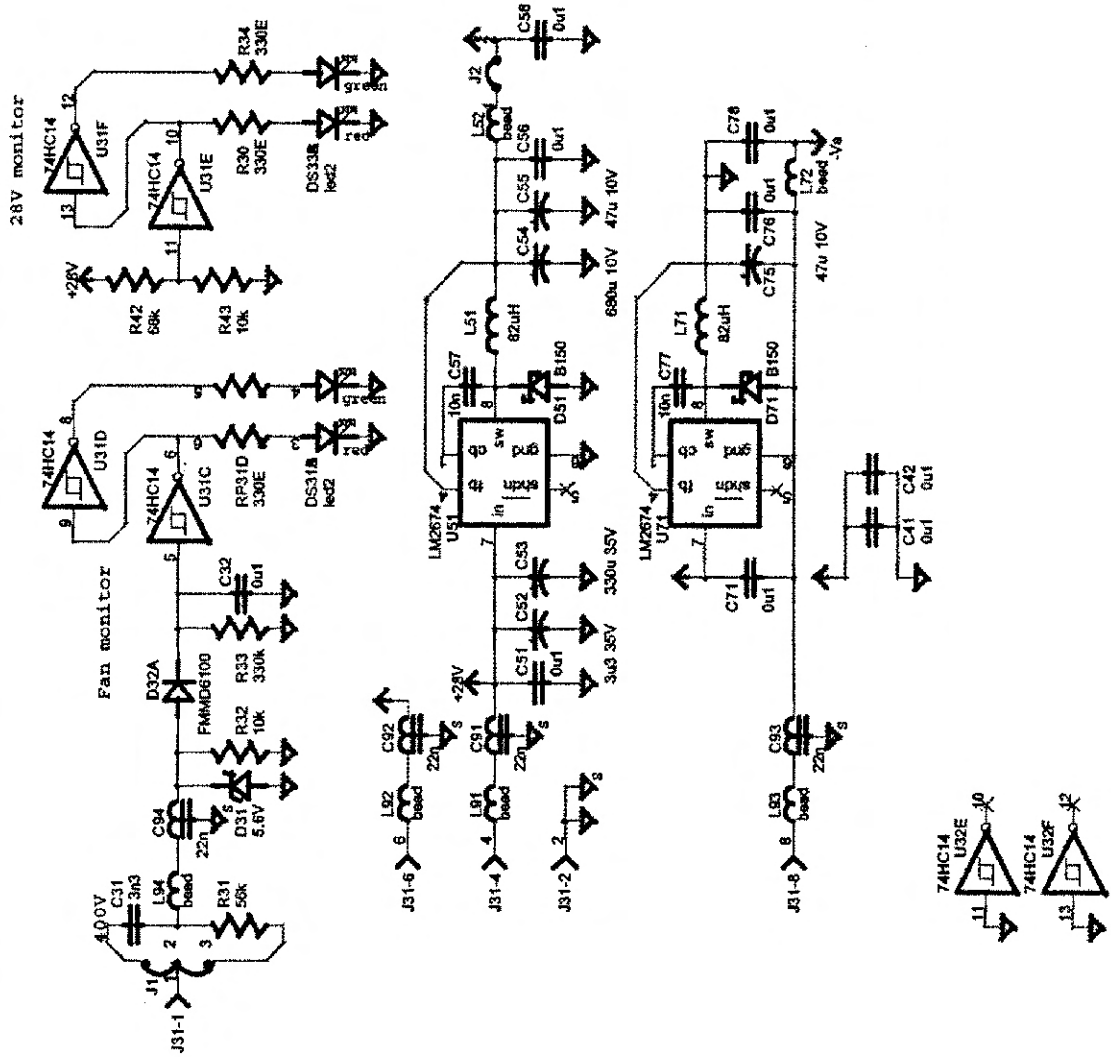

11

Pineapple Technology, Inc.  
 Rocklin, CA  
**1A0035 STATUS BOARD  
 CIRCUIT DIAGRAM**

SIZE	FSCM NO.	DWG NO.	REV
SCALE			SHEET



**D. MFA2PA POWER AMPLIFIER**

**2. PA1K ASSEMBLY TREE**

Item	Qty	Type	P/N	Title	Detail
Top		PL	PA1K	UHF 1KW PA ASSEMBLY U500LD PAs	DIN OUTPUT W/CAPTOR FILTERS
1	1	PL	MF9525	HS RT SIDE U500LD ASSEMBLY	BLF872 LDMOS
2	1	PL	MF9526	HS LEFT SIDE U500LD	BLF872 DEVICES
3	1	PL	MF9539	ISOLATOR & 2-WAY COMB PLATE	U1KWPA ASSEMBLY W/BLF872A
4	2	PL	U500LDA	500W 470-810 MHz POWER PALLET	RGR 4003 032 MATERIAL BLF872
5	1	PL	1A0025	DC ISO/MONITOR CKT	REPLACED CB99
6	1	PS	CT-1326A	CIR W/TABS CH 26 TO 44	Circulator 542-656 MHz
7	1	PS	270600	FT CAP CAPTOR 9 NF 500V	5/16 TERMINALS
8	1	PS	MF9126C	MOLEX BRACKET MTG PLATE	U600LD ALL
9	1	PS	MF9309	REAR PANEL WITH SILK	090 AL ALODYNE
10	1	PS	MF9203 B1	1A0025 PCB MTG PLATE	SM 09 AL W/MTG
11	1	PS	MF9137E	SLED	U500L AL
12	1	PS	454001	HANDLE, REAR	BLK NYLON
13	1	CAT	U250LD	UHF TV 250 W P-SYNC PALLET	470-810 MHz ZINGER COMBINER
14	1	PS	PC9022A_B2	PC BOARD COMB	2-WAY INPHASE 060 1/1 RG
15	1	PL	PC9518A	PCB SET OF (3) BRDS OUTPUT COMB	U1KWPA ASS'Y
16	2	PS	INHOUSE_LABOR	PTI LABOR	
17	.4	PS	INHOUSE-ENG TEST	ENG TESTING AND FIXIT	
18	1	PS	CA4000	COAXIAL ASSEMBLY W/7_16 DIN CON	COAX IS SUPPER FLEX

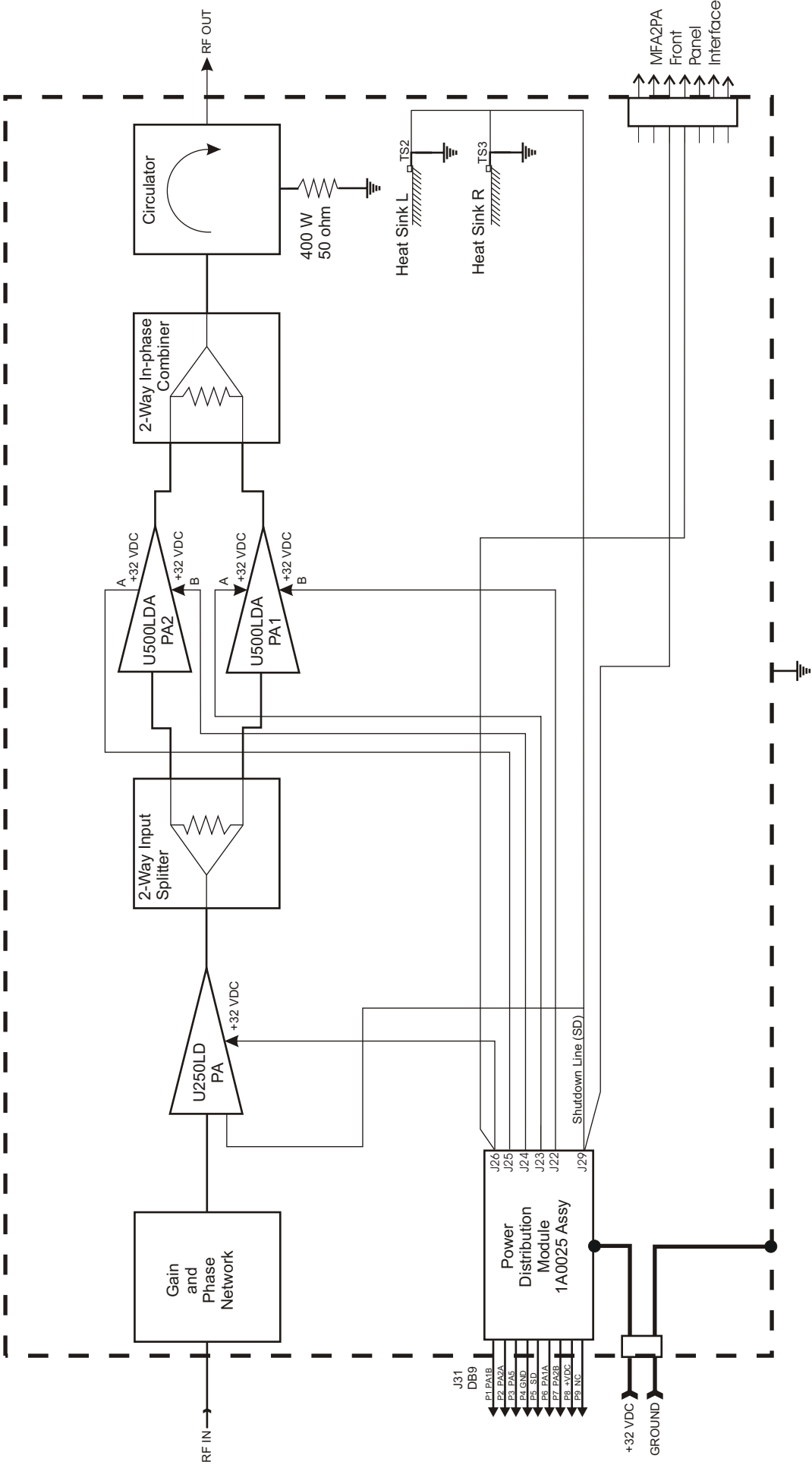

Pineapple Technology, Inc. Rocklin, CA	
PA1K Amplifier Assy BLOCK DIAGRAM	
SIZE: B	SCALE: FIT
PROJECT NO: [REDACTED]	SHEET: 1 of 1
REV: A	



**E. UC200-4 Assy Tree**

Item	Qty	Type	P/N	Title	Detail
Top		CAT	US200-4	UHF 4-WAY SPLITTER	TYPE N 500 WATT



SECTION VI - SCHEMATICS AND PARTS

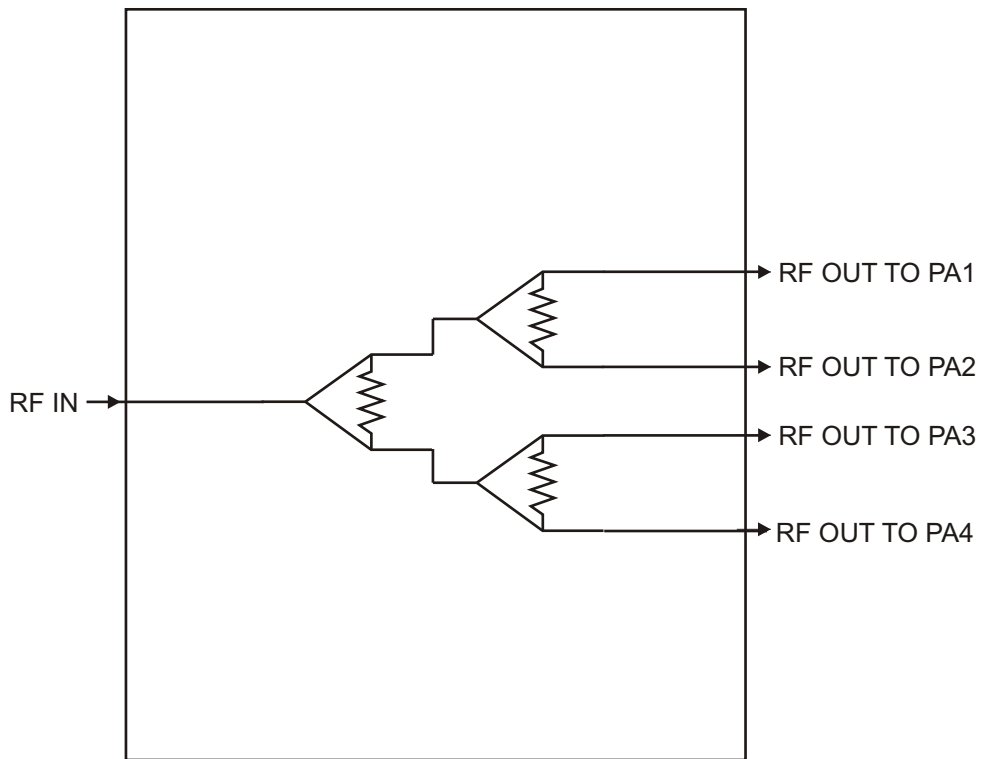

Pineapple Technology, Inc.  
Rocklin, CA

**US200-4 4-WAY SPLITTER  
BLOCK DIAGRAM**

SIZE	ESCM NO.	DWG NO.	REV
SCALE			SHEET

SECTION VI - SCHEMATIC AND PARTS LIST



No Serviceable Parts

Note: Actual unit may not exactly match this photo

Pineapple Technology, Inc.  
Rocklin, CA

UC3KW4NDC Combiner/Coupler  
PHOTO DIAGRAM

SIZE	ESCM NO.	DWG NO.	REV
SCALE			SHEET



SECTION VI - SCHEMATICS AND PARTS

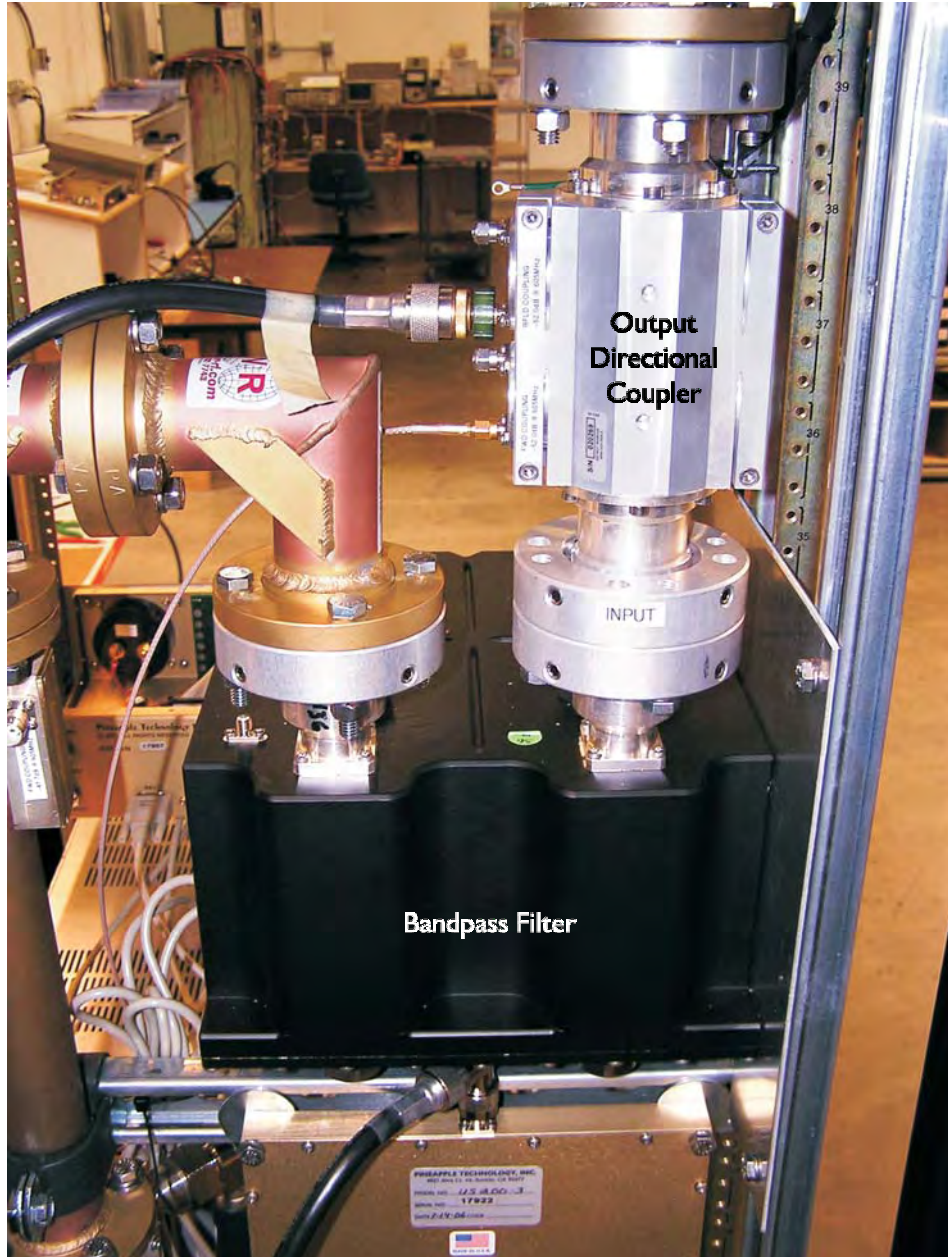

NO SERVICEABLE PARTS

Pineapple Technology, Inc. Rocklin, CA			
<b>BPU3KW BANDPASS FILTER CIRCUIT DIAGRAM</b>			
SIZE	ESCM NO.	DWG NO.	REV
SCALE			SHEET



**E-1 PAS4 SELECTOR SWITCH ASSY**

Item	Qty	Type	P/N	Title	Detail
Top		CAT	PAS10	PA SEL SW FOR ADP500	10 POLE INPUT 1 OUTPUT
1	1	PS	PC9501	PA SELECTER SWITCH	10 POLE ADP500
2	1	PS	483010	SW 10 POLE	ADP500 PA SELECTOR PAS10
3	1	PS	481250	CON DB9 SUB RT ANGLE FM	METAL CASE AMP7457814
4	5	PS	481260	CON DB9 2 SECTION RT ANG	PCB MTG 0.9 SPACING
5	1	PS	MF9342X1	PLATE, FRONT PAS10	W/ PAINT & SILKSCREEN
6	1	PS	MF9343X1	CHASSIS, PAS10	W/ ALODINE & SILKSCREEN
7	1	PS	MF9344X1	COVER, TOP PAS10	W/ ALODINE & SILKSCREEN

**E-2 ADP500 PERFORMANCE MONITOR**

Item	Qty	Type	P/N	Title	Detail
Top		CAT	ADP500	DISPLAY PANEL, ANALOG	SEL SW AND METER
1	1	PL	1A0029	ADP1000 LOGIC PCB	LOGIC BRD PARTS
2	1	PL	1A0030	ADP1000 FP PCB	FP PCB AND PARTS
3	1	PS	471306	FUSE 3AG	6 AMP
4	1	PS	460150	FUSE HOLDER PANEL MTG	3AG TYPE QC CON
5	1	PS	484001	SW, ON/OFF ROCKER AC	CW IND. NAA-211-B121-00
6	1	PS	660103	METER, 2 VOLTS FS	SELCO 39M-0-2VDC
7	1	PL	1A0027	PWR MONITOR CK	PC9052B CBR
8	1	PS	PS2527	POWER SUPPLY OPEN/FRAME	110/220 VAC 27 V 25 W
9	1	PS	484020	TOGGEL SW MOMENTARY/ON	2 POLE
10	1	PS	MF9214	FRONT PANEL	PANEL FRONT ADP500
11	1	PS	MF9011	Cover, Top	ADP1000
12	1	PS	MF9209B	DIVIDER	ADP1000
13	1	PS	MF9208	CHASSIS	ADP500/1KW

# SECTION VI - SCHEMATICS AND PARTS

## J. PAS4 and ADP500

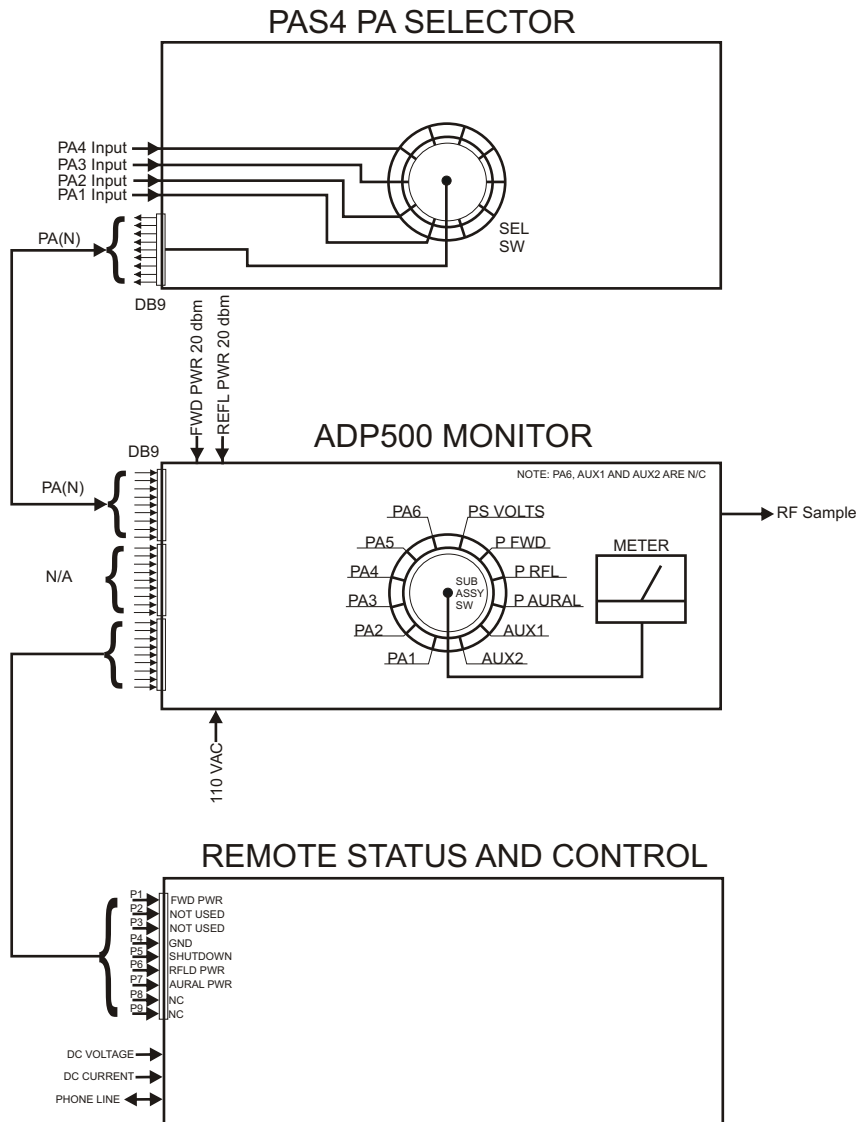

Pineapple Technology, Inc.  
Rocklin, CA

### PAS4 AND ADP500 BLOCK DIAGRAM

SIZE	ESCM NO.	DWG NO.	REV
SCALE	SHEET		

# Section VII

Recommended  
Routine  
Maintenance



VII --- ROUTINE MAINTENANCE (Page 1 of 2)

The following KEY MAINTENANCE AND PERFORMANCE CHECKS should be made monthly or more frequently in some environments where dust and rodents are problems. Pineapple Technology, Inc. recommends that the station provide a data log book to maintain these records.

**DANGER: SOME OF THE RECOMMENDED TESTS REQUIRE THAT THE TRANSMITTER BE OPERATING IN NORMAL MODE. THIS PROCEDURE MUST BE PERFORMED BY A BROADCAST ENGINEER. MORE THAN ONE PERSON SHOULD BE PRESENT IN CASE OF AN ACCIDENT REQUIRING ASSISTANCE. COMMUNICATIONS TO EMERGENCY SERVICES SHOULD BE AVAILABLE.**

TRANSMITTER

- This is an integrated 3KW transmitter and is built around four (4) PA1K amplifier assemblies located in two MFA2PA mainframes.
- Record the transmitter forward and reflected power on the watt meter provided with the transmitter. This measured value will vary with picture content.
- Using the ADP500 and PAS4 record currents for each power LDMOS device in the transmitter. The absolute measured value will vary with picture content so this is best performed with a fixed signal such as SMPTE BARS, however, relative measurements are adequate to indicate a problem at the power device stage. (See operating instructions for ADP500 and PAS4 for more details).
- (OPTIONAL) When the transmitter is first put into service it is a good idea to go through each PA stage and record the static bias level (NO RF DRIVE). This is done by selecting the desired PA and using the PA INHIBIT switch. When this switch is activated, the PA drive is turned off and the bias current can be measured. This is a momentary switch because when it is activated, the PA drive is removed from all the PA's in one half of the transmitter and the output power will be reduced by 6 db. **THIS IS THE BEST METHOD TO USE WHEN TROUBLESHOOTING A POSSIBLE BAD POWER TRANSISTOR.**
- Record the voltage and current measurements displayed on the AUX meter.
- Carefully inspect RF Output coaxial cables for excessive heating or discoloration.
- Check DC Power connections on shunt panels and power supplies for over heating which could indicate the hardware needs attention.
- Check DC Connections on the PA rear panel.
- Remove and clean the air filters located on the front panel of each MFA2PA mainframe assembly. It is safe to remove the filter while the transmitter is operating. The filters may be cleaned with a light detergent and dried completely before re-installing. Spare filters are available from Pineapple Technology, Inc. Request Part Number P/N 990199 when ordering.



**VII --- ROUTINE MAINTENANCE** (Page 2 of 2)

FACILITIES

- Clean all air inlet filters and exhaust outlets to ensure that the transmitter is getting clean unobstructed airflow.
- Perform recommended service on air condition systems.
- Rodent traps or baits should be renewed to keep the facilities clear of these pests which can cause damage to the transmitter.



# Section VIII

Adjustments  
and  
Tuning



VIII --- ADJUSTMENTS AND TUNING (Page 1 of 2)

The UTX3K ULTRA is a new series of transmitters offered by Pineapple Technology, Inc. The latest in LDMOS device and circuit technology are employed to ensure reliable and serviceable operation for many years.

There are very few adjustments necessary to maintain full service condition. The following will give the technician a general overview of locations for locating these adjustments:

1. MODULATOR - See details for all adjustments in the Manufacturer's Instruction Manual provided with your transmitter. Should you have any questions, contact the Pineapple Technology, Inc Engineering staff for assistance.
2. BPU3KW - The bandpass filter provided with your transmitter has been tuned at the factory and adjustments should not be necessary and are not recommended. Any attempt to tune or modify this filter will void manufacturer's warranty.
3. U500LD - This is the main PA board in the transmitter. Under normal operation, no adjustments are necessary. In the unlikely event that a power transistor has to be replaced, the bias adjustments should be reset to insure optimum operation of the transmitter. The following procedure should be followed when making bias adjustments:
  - a. Remove the PA1K amplifier assembly from the transmitter and set it up on a sturdy work bench. The bench should be equipped with a 32 VDC power supply with current capacity of 10 Amps. A VOM will be required to measure the voltage drop across the precision resistors located on the monitor board.
  - b. Attach 50 ohm load resistors to the input port and one to the output port.  
**If this is not done, severe damage to the PA is possible resulting in costly repair.**
  - c. Connect the 32 VDC supply to the DC  $\pm$  terminals. **DO NOT TURN THE POWER SUPPLY ON AT THIS TIME.**
  - d. Locate the circuits where bias adjustments are necessary. Adjust only those circuits where service was performed. Turn the bias adjustment POT's fully counter clockwise. You will find two (2) POT's for each power device with one on each gate. These are small SMT components and require **gentle handling**.
  - e. Locate the current sense resistors on the monitor board. This is a 2 watt .01 ohm precision resistor. There is one for each device.
  - f. Turn the power supply on and measure the +DC to ensure that it reads +32 VDC.
  - g. Measure the voltage drop across the precision resistor. This should read zero (0) VDC. Increase one of the bias POT's slowly till the meter reads 0.009 volts. Increase the second POT until the reading is 0.018 volts. This completes the adjustment.
  - h. Repeat the adjustment above as necessary to set all circuit that have been serviced.

**NOTICE: DO NOT USE THE BIAS CURRENT INDICATED ON THE MONITOR PANEL OF THE ADP500 TO MAKE BIAS ADJUSTMENTS.**



**VIII --- ADJUSTMENTS AND TUNING** (Page 2 of 2)

4. PA PALLETS - These circuits are "FIXED TURNED" and do not require any field adjustment. Any questions regarding pallet adjustments should be referred to the factory.
5. PHASE MATCHED CABLES - If it becomes necessary to replace one of the phase matched cables, contact Pineapple Technology, Inc. for replacements. These cables are the ones connected to the input and output ports on the PA1K.
6. OUTPUT POWER - The transmitter output power measurement is made using a calibrated wattmeter provided with the transmitter. No adjustments are necessary here.
7. GAIN & PHASE MATCHING - Under normal conditions it is not necessary to make any gain or phase adjustments in the transmitter. This transmitter is equipped with provision to adjust phase and gain to ensure minimum power loss in the dump load and maximum forward transfer power to the antenna. Contact Pineapple Technology, Inc. for details if this becomes necessary.

# Section IX

Problem  
Solving  
&  
Troubleshooting



## IX - PROBLEM SOLVING & TROUBLE SHOOTING (Page 1 of 3)

The UTX3K ULTRA is a "MODULAR ASSEMBLY" where most of the sub-assemblies can be removed and or replaced as necessary to maintain full service. To service this transmitter, it is best to become familiar with the various sub-assemblies by reviewing the transmitter block diagram and it's associated subs shown in the introduction. Any work performed on a transmitter licensed by the FCC must be performed by qualified personnel.

### FAILURE ANALYSIS STARTS WITH THE FOLLOWING ASSUMPTIONS:

1. The transmitter is connected to an AC source which is within the specified voltage range and has ample power to run the transmitter.
2. The antenna has been checked out and a proper match has been verified.
3. The room temperature is < +35 degrees Celsius (+95 degrees Fahrenheit)
4. There are no restrictions in the air flow in or out of the building.
5. The video and aural signals to the modulator comply with stated specifications.

### CHECKING THE WARNING LIGHTS

There are several warning signals visible on the front of the transmitter that will alert the technician of possible problems. When viewed from the front, all the lights should be GREEN indicating normal operation. An alert signal is indicated by a RED light. We will focus on RED alert signals in this section.

#### MFA2PA ASSEMBLY

FAN FAULT                      RED indicates that the fuse supplying AC to the fan has failed. The fuse is located just inside the front panel near the top.

CHECK: FUSE AND/OR FAN

DC SUPPLY                      RED indicates a loss of +32 VDC to PA

CHECK: DC supply voltage to the rear of the PA1K  
CHECK: DC supply fuse located on the Fuse panel located at the bottom of the rack in the rear.  
CHECK: AUX panel location in the bottom half of the rack being checked for proper voltage and current readings

NOTE: If all the ALERT lights are on in a given rack, this could indicate that a breaker has tripped

CHECK: Circuit breakers located on the front of the ACDIS2 or the sub-panel breaker located at the MAIN AC supply.



## IX - PROBLEM SOLVING & TROUBLE SHOOTING (Page 2 of 3)

- SHUTDOWN**      RED indicates that the PA has been "SHUTDOWN". There are two possible reasons for this:
1. Heat Sink over temperature thermostat has tripped protecting the PA  
  
CHECK: Air inlet filter for possible restrictions to air flow  
CHECK: Fan air flow for possible fan fault  
CHECK: Room temperature
- Note: Heat sink over temperature fault is indicated by the RED alert light going ON/OFF in cycles varying in duration depending on air flow. The PA returns to normal operation automatically when the problem is corrected.
2. Remote Shutdown by external signals coming from other protection circuits.  
  
CHECK: Transmitter global protection circuits.

### ADP500 MONITOR

The ADP500 is a general purpose test instrument used to display PA status and measure voltage, current and RF power levels. When combined with the PAS4 it is possible to measure the current being drawn by each PA RF Device. In addition to its measurement features, it serves to integrate fault signals for PA Assemblies, High VSWR alarms and provides an interface to the RM8 Remote Control Unit. The ADP500 is a diagnostic tool for troubleshooting the transmitter.

With normal operating conditions, all the LED's on the front panel are GREEN. Red LED's could indicate a fault in the transmitter that require attention.

- RF PWR OFF LED is RED**      Will occur anytime the "SHUTDOWN LINE" (SD) is set to zero (0) volts. The following conditions will pull the set SD to zero volts:
1. Antenna VSWR HIGH
  2. PA INHIBIT SWITCH actuated.
- ANT VSWR HIGH LED is RED**      This indicates that the antenna reflected power exceeded the set trip point. This is an internal setting performed at the factory and is normally set to 10% of the RF OUTPUT POWER set point.
- CHECK: The transmitter output connections and antenna for possible faults. The fault condition will automatically reset when the problem is corrected.



### IX - PROBLEM SOLVING & TROUBLE SHOOTING (Page 3 of 3)

PA1 - PA5 LED's are RED

This will indicate that the PA Pallet currents are below the 500 ma set point. This can occur when the PA Power device has failed.

CHECK 1: Select the PA device in question for current display on the multi-meter. Compare the reading to the station log. If abnormal, it is possible that a power transistor has failed.

**NOTICE:** PA5 will go RED when the INHIBIT SWITCH is actuated.

CHECK2: To confirm a failed device, it is necessary to shutdown the transmitter and remove the PA1K power amplifier assembly and check the device in question. Use a VOM to check the resistance from the gate of each 1/2 of the device to ground. If either reading is below 1K ohm it is likely that the device has failed.

### POWER SUPPLY MODULE LED RED

The Power Supply Module has two warning LED's located on the front panel. Normally these LED's are GREEN indicating that the AC Line voltage and the OVER VOLTAGE circuits are operating properly. If either LED turns RED the module in question will be turned off and is no longer supplying power to the transmitter. These modules are "HOT PLUGGABLE" and can be removed from active service by simply removing it from the main frame. Pineapple Technology, Inc. does not recommend any attempt to service these modules. Any attempt to service may void factory warranties. Return the module to Pineapple Technology, Inc. or to the manufacture for service.

**NOTICE:** If it becomes necessary to operate the transmitter with a missing supply module, very little if any performance degrading will be experienced. Check the AUX volt meter for any indication of a drop in voltage (normally 32 VDC). This drop is caused by the power supply modules going into "CURRENT LIMIT". It is important that the voltage be around 32 volts  $\pm 0.5$ . If the voltage falls below this point, it can be recovered by reducing the RF Drive level a small amount in most cases. This should be done only with the DUMP LOAD MONITOR on and indicating that the maximum power is not exceeded.

# Section X

Warranty





## X -- WARRANTY

The WARRANTY provided by Pineapple Technology, Inc. (PTI) on this transmitter is detailed below. It should be noted that some of the equipment sub-systems have warranty coverage by the original manufacture that differs from the standard warranty provided by PTI. Warranty details on equipment falling into this category may be found in the Manufacturers instruction manual provided with the transmitter. In all cases, replacement units of this equipment are normally in stock at PTI for quick turn service support to our customers during the PTI Standard Warranty period.

### STANDARD WARRANTY

Seller warrants that each Product sold by it is free of defects in materials and workmanship. Seller's obligation under said warranty continues for a period of one (1) year from date of shipment. Repairs or replacement of defective parts shall be the sole and exclusive remedy under warranty, at Seller option, provided that Seller may, as an alternative, elect to refund an equitable portion of the purchase price of the product. THIS WARRANTY IS EXPRESSLY IN LIEU OF AND EXCLUDES ALL OTHER EXPRESS OR IMPLIED WARRANTIES, INCLUDING BUT NOT LIMITED TO WARRANTIES OF FITNESS FOR A PARTICULAR PURPOSE, USE, OR APPLICATION, AND ALL OTHER OBLIGATIONS OR LIABILITIES ON THE PART OF THE SELLER, UNLESS SUCH OTHER WARRANTIES OBLIGATIONS OR LIABILITIES ARE EXPRESSLY AGREED TO IN WRITING BY SELLER.

### WARRANTY REPLACEMENT AND REPAIRS

All claims under warranty must be made promptly after occurrence of circumstances giving rise to thereto and must be received within the applicable warranty period by seller or its authorized representatives. Such claims must be documented on a PTI\* Field Failure Report with a full description of the circumstances giving rise to the claim. Before any products are returned for repair and/or adjustment, written authorization from seller or its authorized representative for the return and instructions as to how and where these products should be shipped must be obtained. This is to include a Return Authorization (RA) number provided by the seller or authorized representative, this must accompany ALL returns. Any product returned to the seller for the examination shall be sent prepaid via the means of transportation indicated as acceptable by seller. Seller reserves the right to reject any warranty claim not promptly reported and any claim on any item that has been altered, i.e. circuit modifications, components removed, or has been shipped by non acceptable means of transportation. When a product has been returned for examination and inspection, or for any other reason, customer shall be responsible for all damage resulting from improper packaging or handling, and for loss in transit, notwithstanding any defect or nonconformity in the product. In all cases the seller has sole responsibility for determining the cause and nature of the failure, and the Seller's determination with regard thereto shall be final. If it is found that Seller's Product has been returned without cause and is still serviceable, customer will be notified and the Product returned at its expense, in addition, a charge for testing and examination may, in Seller's sole discretion be made on Products so returned.

*\* A field Failure Report is included at the end of this manual - Additional Field Failure Reports can be obtained by calling Pineapple Technology, Inc. at (916) 652-1116 or you may download one from our website at [www.ptibroadcast.com](http://www.ptibroadcast.com) in the Warranty section.*

# Section XI

Extended  
Warranty