

UTX3KW - A
INSTRUCTION MANUAL

SN: _____

PINEAPPLE TECHNOLOGY, INC.



Section I — SAFETY NOTICES2
 READ THIS SECTION BEFORE INSTALLATION

Section II — TRANSMITTER SPECIFICATIONS3

Section III — TRANSMITTER INSTALLATION.....5

Section IV — TRANSMITTER TURN-ON.....6

Section V — THEORY OF OPERATION

- A. Introduction8
- B. ACDIS38
- C. RR6000 Power Supply8
- D. PAS10 and ADP500 Performance Monitor11
- E. Remote Monitor and Control W/ABS12
- F. Modulator/Driver.....13
- G. DRV100DC-2 Driver.....13
- H. S10-613
- I. MFA1KW Power Combiner.....13
- J. U600LDV-2 Power Amplifier.....13
- K. UC3KW-DC40 Power Combiner14
- L. BPU3KW UHF.....14
- M. AUX5 Monitor Panel.....14
- N. FP6 Fuse and DC Distribution Panel.....14

Section VI — SCHEMATIC AND PARTS LISTS

- A. UTX3KW-A15
- B. ACDIS317
- C. DRV100DC-219
- D. MFA1KW21
 - 1. 1A0035 Status Board.....23
- E. U600LDV-225
 - 1. U250LD.....28
 - 2. 1A0025 Power Distribution Monitor.....32
 - 3. 1A0018 Gain and Phase Matching Network.....35
- F. SPLITTER S10-637
- G. COMBINER UC3KW.....38
- H. PAS10 and ADP500 PA Monitor.....39
 - 1. 1A002746
 - 2. 1A002948
 - 3. 1A003051
- I. AUX5 Monitor Panel.....52
- J. FP6 Fuse and Shunt Panel54

Section VII — RECOMMENDED ROUTINE MAINTENANCE55

Section VIII — ADJUSTMENTS AND TUNING56

Section IX — PROBLEM SOLVING / TROUBLE SHOOTING58

Section X — WARRANTY60

Section XI — EXTENDED WARRANTY61



I — SAFETY NOTICES

****READ THIS SECTION BEFORE INSTALLATION****

SEVERE ELECTRICAL SHOCK OR BURNS MAY OCCUR IF
THIS EQUIPMENT IS USED IMPROPERLY.

~~~~~`

NEVER WORK ON THIS EQUIPMENT ALONE. ALWAYS HAVE ANOTHER PERSON PRESENT  
WHILE WORKING ON ELECTRICAL CIRCUITS OR MOVING EQUIPMENT. COMMUNICATIONS  
TO EMERGENCY SERVICES SHOULD BE AVAILABLE AT ALL TIMES.

~~~~~`

BEFORE CONNECTING THIS EQUIPMENT TO ANY AC ELECTRICAL SOURCE READ THE
SECTION ON INSTALLATION. ALL ELECTRICAL WIRING FOR THIS EQUIPMENT MUST BE
PERFORMED BY QUALIFIED ELECTRICIANS. ALL WIRING MUST BE COMPLIANT WITH
LOCAL ELECTRICAL CODES.

~~~~~`

POWER AMPLIFIERS AND SUPPLIES ARE HEAVY. TO INSTALL THIS EQUIPMENT IN RACKS,  
USE TWO (2) PERSONS TO AVOID POSSIBLE INJURIES.

~~~~~`

NEVER OPEN THE CABINET ENCLOSURE OR UNPLUG CABLES OR WIRES WHILE THIS
EQUIPMENT IS OPERATING.

~~~~~`

ALL SERVICE WORK MUST BE PERFORMED BY QUALIFIED TECHNICIANS ONLY.  
IF ONE IS NOT AVAILABLE LOCALLY, CONTACT PINEAPPLE TECHNOLOGY, INC. FOR  
A LIST IN YOUR AREA.



**II — UTX3KW-A SPECIFICATIONS**

**OPERATING**

|                             |                                |
|-----------------------------|--------------------------------|
| Power Output .....          | 3 KW Peak Sync                 |
| Aural Power .....           | 300 Watts                      |
| RF Output Impedance.....    | 50 Ohms                        |
| Frequency Range .....       | 470-806 MHz                    |
| Frequency Stability.....    | 1 PPM or better                |
| Harmonic and Spurious ..... | -60 dB or better ref to P-sync |
| Power Consumption .....     | 17 KW maximum                  |
| AC Line Voltage .....       | 208-230 V AC 3-Phase           |

**VIDEO PERFORMANCE**

|                                   |                                                                                     |
|-----------------------------------|-------------------------------------------------------------------------------------|
| Visual Frequency Response.....    | +/- 1 dB across the TV channel -1.25 MHz to 4.75 MHz<br>relative to visual carrier. |
| Differential Gain.....            | <7 %                                                                                |
| Differential Phase .....          | <10 degrees                                                                         |
| ICPM .....                        | <5 degrees                                                                          |
| Low Frequency Linearity .....     | <15 %                                                                               |
| 2T K Factor.....                  | 3 %                                                                                 |
| Group Delay .....                 | Meets FCC Part 73 Rule                                                              |
| Video Input Impedance.....        | 75 ohms                                                                             |
| Video Input Level .....           | 1 volt p-p                                                                          |
| Variation of output power .....   | <5 %                                                                                |
| Regulation of output power .....  | <5 % Typical                                                                        |
| Video Signal to Noise Ratio ..... | < 45 dB un-weighted                                                                 |

THESE SPECIFICATIONS ARE SUBJECT TO CHANGE WITHOUT NOTICE.



**AUDIO PERFORMANCE**

|                             |                                               |
|-----------------------------|-----------------------------------------------|
| Audio Response .....        | Meets FCC pre emphasis curve                  |
| Distortion .....            | <1 % THD                                      |
| FM Noise .....              | 50 dB or better                               |
| AM Noise .....              | 40 dB or better                               |
| AM Synchronous Noise .....  | 40 dB typical                                 |
|                             |                                               |
| Operating Temperature ..... | -10 to +35 Celsius Ambient                    |
| Altitude .....              | 5000 feet without additional cooling          |
| Cooling requirements .....  | Unobstructed air flow 2500 CFM minimum        |
| RF Output connectors.....   | 1 5/8 EIA Flange                              |
| Weight.....                 | 525 pounds                                    |
| Dimensions .....            | 80 inches x 22 inches x 24 inches (H x W x L) |

THESE SPECIFICATIONS ARE SUBJECT TO CHANGE WITHOUT NOTICE.



### **III — TRANSMITTER INSTALLATION**

To ensure long and reliable trouble-free service from the UTX3KW-A transmitter the following steps for installation are recommended.

1. **MECHANICAL INSTALLATION:** The UTX3KW-A was designed to be installed in a building protected from the weather. The building should have a hard-surface floor such as concrete with a moisture barrier. This barrier could be pressure-treated wood sub flooring which could be anchored to the concrete and to the transmitter to make the installation earth quake resistant.

Allow a minimum of three feet around the transmitter cabinet for service access. The top of the transmitter should be clear, for three feet above to allow the air to exhaust from the transmitter.

Air flow thru the transmitter is approximately 2500 CFM. Provisions for air inlet and exhaust from the room must allow air flow with minimal obstruction. In the event that the room temperature exceeds 35 degrees Celsius, cooling air must be provided so that the room temperature will not exceed 35 degrees Celsius under worse case conditions.

Notice: This equipment is **HEAVY** and must be handled by professional movers with proper equipment. Any damage caused by the installers is not covered under warranty. Check to ensure that installing crews have proper insurance coverage.

2. **GROUNDING:** Transmitter grounding is **VERY IMPORTANT** and must be done correctly for safety and operational reasons. A typical installation may be done as follows:

Use a heavy gauge wire such as #2 AWG stranded copper or solid copper buss one (1) inch wide by 1/8 inch thick for connections. The bonding between the transmitter and the ground rods must be good quality and protected from corrosion. The ground wires should run over the floor and connected to the ground rods located outside the building. The wire should not go thru the concrete floor but over and around it.

3. **AC WIRING:** A ten (10) foot cable has been provided with the transmitter to facilitate the connection to the AC Main power source.

Connections to the AC Main should be made as follows:

- RED, BLACK, AND ORANGE are connected to the 208 VAC 3-PHASE terminals
- WHITE WIRE is connected to the NEUTRAL terminal
- GREEN WIRE is connected to the SAFETY GROUND

NOTICE: All wiring of this type must be done by A QUALIFIED ELECTRICIAN and must conform to LOCAL and NATIONAL wiring CODES.

Consult with your electrician to ensure that the proper breaker size is selected for the main circuit.

4. **ANTENNA CONNECTION:** The transmitter is equipped with 1 5/8 EIA Flange connector located at the top of the rack. Conditions vary from site to site so some engineering may be required to ensure that the antenna is receiving the correct amount of power to comply with FCC licenses and to ensure safety from lighting etc.



## **IV— TRANSMITTER TURN ON PROCEDURE**

Before applying AC Power to the transmitter for initial turn on and check out, the installation should be approved by a qualified broadcast engineer. The turn on procedure that follows is recommended by Pineapple Technology, Inc. engineering staff:

1. Check transmitter load or antenna for proper installation and connection to the transmitter.
2. Open the transmitter and inspect all cables and wires for loose connections or broken wires in the rack assembly.
3. Check for damage to the equipment mounted in the rack.
4. Check all AC breakers and on/off switches to ensure that all are **OFF**.
5. TURN ON THE MAIN AC BREAKER LOCATED IN THE SUB-PANEL WHERE THE AC POWER CORD WAS CONNECTED.
6. TURN ON THE MAIN AC BREAKER LOCATED ON THE ACDIS3 POWER DISTRIBUTION PANEL LOCATED ON THE FRONT OF THE TRANSMITTER. A GREEN LIGHT SHOULD COME ON INDICATING POWER IS ON.
7. TURN ON THE AC SWITCH LOCATED ON THE FRONT OF THE ADP500. THE INDICATING LIGHTS SHOULD BE ON AND READY FOR OPERATION
8. TURN ON THE AUX BREAKER LOCATED ON THE ACDIS3 FRONT PANEL. THE PA FANS AND THE RACK EXHAUST FANS SHOULD COME ON.
9. TURN ON THE POWER SUPPLY BREAKERS LOCATED ON THE FRONT OF THE ACDIS3. CHECK THE RR6000 POWER MODULES — six (6) EACH — TO SEE IF THE GREEN LIGHTS ARE INDICATING NORMAL OPERATION.
10. USING THE ADP500 & PAS10 CHECK THE IDLING CURRENTS ON EACH PA TO ENSURE THAT THE CURRENTS ARE IN THE CORRECT RANGE. TYPICAL RANGE IS 1.5 TO 2.5 AMPS. SEE ADP500 OPERATING SECTION FOR DETAILS.
11. TURN ON THE DRV100 DRIVER AMPLIFIER — THE GREEN LIGHT SHOULD COME ON.

NOTICE: The Modulator/Upconverter has been set at the factory so that the output power indication on the ADP500 will show 100% or 3 KW p-sync power level. It is important to read the instruction manual supplied with the modulator to locate key adjustment devices on the front panel. The output level adjustment will be necessary for the next step in the turn on procedure.

12. Locate the level adjustment on the modulator/upconverter and turn the level down to minimum or CCW.
13. Turn on the power switch located on the modulator rear panel.



14. Apply a video signal (1 volt P-P) to the video input terminal.
15. Slowly increase the output level adjustment while watching the RF Output level on the ADP500. When the output gets up to 50% indicated power stop the adjustments.
16. Using the ADP500 reflected power indication check the LOAD reflected power. This should be less than 5% reflected.
17. Return to the PA current readings on the ADP500 to verify that all the currents are approximately the same.
18. With successful performance thru step 17, the transmitter output power can be increased using the output level adjustment on the modulator to achieve 100%. The aural power can be added at this time not exceeding 10% of output p-sync power as indicated on the ADP500.





## **V— THEORY OF OPERATION**

### **A. INTRODUCTION**

The UTX3KW-A transmitter was designed to meet or exceed all FCC applicable specifications for TV Broadcast Equipment. Special attention was given to the selection of sub-assemblies and components to achieve maximum reliability and minimum down time. The construction of the UTX3KW-A is BASIC and MODULAR with most components field replaceable. Special emphasis was placed on “**KEEPING IT SIMPLE**” and returning to more traditional transmitter layouts and instrumentation.

This transmitter was designed for Analog (NTSC) transmission with provisions and options available to convert to Digital Service when necessary.

Refer to the UTX3KW-A block diagram (page 15) for an overview of the transmitter architecture. This will give the technician basic information needed to understand the operations of the transmitter and the function of each subassembly.

SEE SECTION VI.A (Page 16) FOR PARTS LIST.

### **B. ACDIS3 AC DISTRIBUTION**

The ACDIS3 is the primary AC power inlet module. The UTX3KW-A transmitter was designed to except 208 to 230 V AC 3-PHASE using a FIVE (5) wire connection. The five wires are:

- 3 wires for 208-230V AC 3-Phase
- 1 wire for neutral connection
- 1 wire for safety ground connection

**CAUTION:** Connection to the AC Primary Source must be made using all five wires listed above. Follow the wiring instruction given in the AC WIRING (page 5; section III. 3.) If not followed, severe damage to the transmitter and or electrical shock is possible.

The ACDIS3 performs the following functions:

1. Provides a primary AC power breaker point to shutdown the transmitter.
2. Provides 208 VAC power to each of the 2 KW DC power supplies with individual breaker points for added safety.
3. Provides 110 VAC circuits for Modulator, ADP500, ABS (auxiliary power source), and AUX Power where needed.

SEE SECTION VI.B (Page 17) FOR SCHEMATIC AND PARTS LIST

### **C. RR6000 POWER SUPPLY**

The UTX3KW-A transmitter is designed with over 12 KW of DC power available to the transmitter. To achieve this level, the power supply is made up of six (6) RR6000 power modules mounted into two (2) main frame assemblies which are capable of managing three (3) 2 KW modules each.

The power modules are “HOT PLUGGABLE” and can be removed or installed without turning off the transmitter.

Each power supply module has OVER VOLTAGE, OVER CURRENT, AND OVER TEMPERATURE protection as well as a fault signal in the event of a failure.

REFER TO MANUFACTURER’S MANUAL PROVIDED WITH THE UTX3KW-A.



**D. ADP500 & PAS10 PERFORMANCE MONITOR**

The ADP500 & PAS10 (PERFORMANCE MONITOR) provides the following functions:

1. Monitors FORWARD AND REFLECTED POWER to the antenna and presents it as a percentage of power rating. The transmitter comes set to 100% P-Sync power based on the ratings of the transmitter.
2. Monitors Aural Power as a percentage of P-Sync rating (5-10 % typical)
3. Provides a HIGH ANTENNA VSWR MONITOR in the event of an antenna or coax failure where the reflected power exceeds 25% the transmitter will shutdown. Front panel LED will change from green to red in case of a fault.
4. Provides current monitoring of all the pallets used in the six (6) U600LDV-2 power amplifier assemblies. The current levels can be read directly from the multi-meter on the front panel. Individual pallets are selectable on the ADP500 and the PA assemblies are selected using the PAS10. In normal operations, a PA FAULT is indicated by going from green to red. RED indicates that the current level is below 500 ma and a transistor could have failed. To read the actual current, select the appropriate PA Bank using the PAS10. The ADP500 will now display status of each pallet in that PA. The multi-meter will read the actual current.
5. A PA INHIBIT switch is provided for failure diagnostic purposes. When activated, this switch allows the technician to monitor the bias currents for each pallet. These readings should be recorded when the transmitter is first installed and used as a reference. This is the best way to trouble shoot possible transistor problems. When in the PA INHIBIT mode, the RF PWR OFF LED will change from green to red indicating that the “SHUTDOWN LINE” is at a TTL 0 state and the output power has been reduced to near zero.
6. An RF MONITOR port (BNC) is available to connect a spectrum analyzer for monitoring the output signal.

**METER SELECTOR SWITCHES**

The PAS10 is used to select the appropriate PA Module (U600LDV-2) for performance display on the ADP500. PA designations are PA1 starting from the top row going left to right with PA6 being on the right side in the third row down when viewed from the front of the transmitter.

The Rotor Switch on the ADP500 is the detail selector for the multi-meter. The various positions are defined as follows:

|                    |                                                                                                                                                                                       |
|--------------------|---------------------------------------------------------------------------------------------------------------------------------------------------------------------------------------|
| PA1 THRU PA5 ..... | Reads PA pallet currents as selected<br>Typical reading in INHIBIT MODE 1.5 TO 2.2 A<br>Typical reading SMPTE BARS 5-7 A for PA1 thru PA4<br>Typical reading SMPTE BARS 2-3 A for PA5 |
| PA6 .....          | NO CONNECTION                                                                                                                                                                         |
| PS VOLTS.....      | Reads DC voltage applied to PA stages<br>Typical reading would be +29 to 32 VDC                                                                                                       |
| P FWRD .....       | Reads PA output power in P-Sync percentage of rating<br>Full power reading would be 100%                                                                                              |



- P RFLD..... Reads PA output power being returned from the load and displayed as a percentage of forward power. Typical reading would be < 5% indicated
- P AURAL..... Reads the AURAL POWER component as a percentage of forward power. Typical reading would be 10%
- AUX 1 & AUX 2 ..... not used in this configuration

REFER TO SECTION VI.H (Page 39) FOR SCHEMATICS AND PARTS LIST

**E. REMOTE MONITOR AND CONTROL WITH ABS**

This equipment is OPTIONAL and can be used to satisfy FCC remote control requirements.

The Remote Monitor is used to monitor the operational status of the transmitter and will allow the operator to turn RF on or off and adjust power levels. The following items are monitored or controlled:

1. Transmitter on/off function
2. Power output level monitor and adjust
3. AC Line voltage status — With ABS you can be notified if there is a power failure at the side.
4. Various other custom options are available. Specify these at the time the transmitter is purchased and they will be included if possible.

Remote monitoring requires a phone line connection. Information can be accessed via a PC Terminal or via a “VOICE COMMAND LINE.” Either option is standard with this system.

The Auxiliary power unit requires a battery connection. A common car battery (12 VDC) can be used with a charger as an ABS. This will run the Monitor and provide access to transmitter status for several hours.

A manual for this equipment is provided by the Manufacturer and is included in the UTX3KW-A package shipped with the transmitter. **This manual is only included if this option was purchased for delivery with the transmitter.**

REFER TO INSTRUCTION MANUAL PROVIDED WITH THIS PACKAGE.

**F. MODULATOR**

The heart of any TV Transmitter is the **MODULATOR**. This equipment receives the video and audio signals as well as any control signals needed. The base band signals are converted to RF with an output on the desired operating channel.

Detail operation of the Modulator with schematics and parts list is provided by the equipment manufacturer.

REFER TO INSTRUCTION MANUAL PROVIDED WITH THIS PACKAGE.



### **G. DRV100DC-2 DRIVER**

The output power of the modulator is applied to the input of the DRV100DC-2 driver. This amplifier increases the drive level to that required for the MFA1KW to make rated power. The driver amplifier requires 31 VDC to operate and does not require any tuning or adjustments to change channels.

REFER TO SECTION VI.C. (Page 19) FOR SCHEMATIC AND PARTS LIST.

### **H. S10-6 SPLITTER**

The S10-6 SPLITTER is a 6-way in-phase broadband splitter. This splitter provides an equal split of drive power to each U600LDV-2 power amplifier.

SEE SECTION VI.F. (Page 37) FOR PARTS LIST

### **I. MFA1KW PA HOUSING**

The MFA1KW is the main RF Power Amplifier housing which accommodates two (2) U600LDV-2 Amplifiers. The housing includes the following:

- 2 ea. 330 CFM cooling fans
- 2 ea. Air filter assemblies
- 2 ea. Front panel status PC boards
- 1 ea. Main chassis
- 2 ea. Mechanical slide assemblies
- 1 ea. AC Filtered inlet for cooling fans

SEE SECTION VI.D. (Page 21) FOR SCHEMATICS AND PARTS LIST

### **J. U600LDV-2 POWER AMPLIFIER**

The U600LDV-2 is the main RF Power Amplifier Assembly used in the UTX3KW-A. Each Amplifier assembly is made up of five (5) U250LD power pallets. Each power pallet uses two (2) Philips BLF861A power LDMOS FETs. These amplifiers are operated in Class A/AB or sometimes referred to as “HARD AB”. This refers to the bias levels to achieve best linearity.

Each U600LDV-2 amplifier assembly includes the following:

- 5 ea. U250LD power pallets
- 1 ea. 4-way splitter
- 1 ea. 4-way combiner
- 1 ea. phase & gain matching circuit (1A0018)
- 1 ea. Power distribution module (1A0025)
- 1 ea. high power isolator
- 3 ea. thermal sensors
- 1 ea. remote monitor port (DB9)
- 1 ea. front panel status port (Molex)
- 1 ea. filtered DC input port
- 1 ea. Type N panel mounted RF Input port
- 1 ea. Type N Panel mounted RF Output port

SEE SECTION VI.E. (Page 25) FOR SCHEMATICS AND PARTS LIST.



### **K. UC3KW-DC40 COMBINER/DD COUPLER**

The UC3KW is a 6-way in phase combiner with built in 40 dB dual directional coupler. The combiners are designed for the channel designated for the transmitter. This is a closed unit and cannot be serviced.

SEE SECTION VI.G. (Page 38) FOR PARTS LIST

### **L. BPU3KW UHF BAND PASS FILTER**

This Band Pass filter was designed to meet FCC Certification requirements with minimum loss of RF Power. The BPU3KW comes tuned and tested to the operating frequency of the transmitter and should not be adjusted without proper equipment. Replacement filters are available as P/N BPU3KW UHF (+CHANNEL NUMBER).

### **M. AUX5 MONITOR PANEL**

The auxiliary monitor panel provides analog meter measurements for the primary DC supply. The total power supply current and voltage are displayed on these meters. These measurements serve as a good indication of the operations of the transmitter final power amplifiers.

Each power supply has a current monitor output. These outputs are accessible on the AUX5 Front panel. Each ( PS I SHARE ) test point will indicate a relative amount of current being supplied from the power supply. This is not a calibrated or accurate measurement that is scaled from the current capability of the power supply. This is also a second-level diagnostic tool for use by qualified technicians.

In the event of an EMERGENCY, a SHUTDOWN SWITCH located on the AUX5 will shut down the transmitter and remove all power starting from the MAIN 3-P BREAKER. To turn the transmitter on, it is necessary to RECYCLE the SHUTDOWN SWITCH before the transmitter MAIN BREAKER can be turned on.

### **N. FP6 FUSE AND SHUNT PANEL**

The FP6 serves as a DC SUMMING POINT for all current coming from the power supplies. After being summed the current passes through a 500 AMP precision shunt which is used for measuring the total supply current and voltage being applied to the transmitter power amplifiers. At this point, the DC Power is distributed to each U600LDV-2 amplifier assembly thru a series 80 amp fuse.

**NOTICE: BEFORE ANY SERVICE WORK IS PERFORMED ON THE FP6 ALL POWER TO THE TRANSMITTER MUST BE TURNED OFF FOR SAFETY.**



**VI — SCHEMATICS AND PARTS LIST**

**A. UTX3KW-A — Block Diagram**

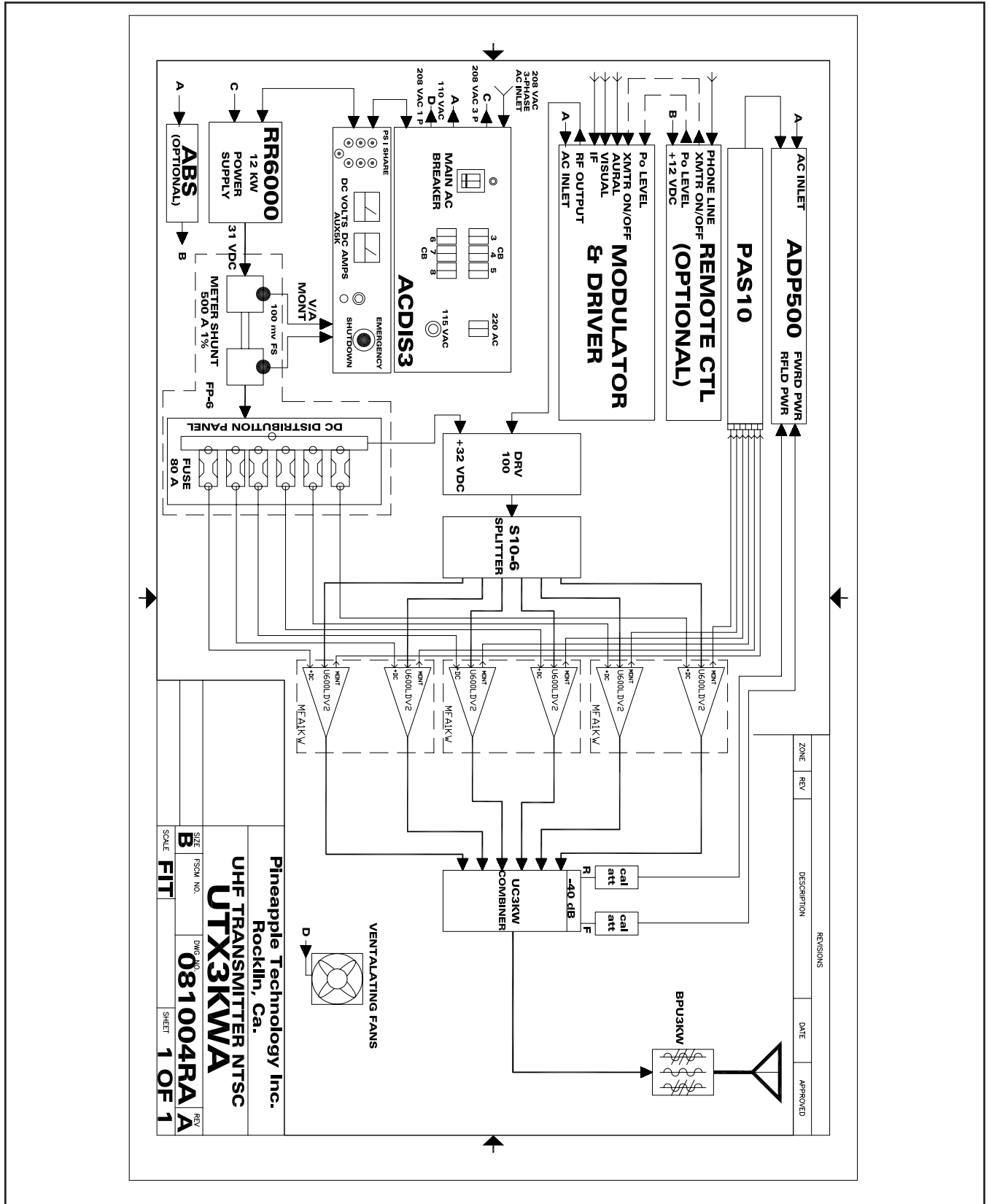



**VI — SCHEMATICS AND PARTS LIST**

**A. UTX3KW-A — Parts List**

Printed 9/3/2004

UHF TV XMTR ANALOG  
 470 MHz TO 810 MHz

|          |           |       |
|----------|-----------|-------|
| Type     | CAT       | User1 |
| Revision | A         | User2 |
| Status   | U         | User3 |
| Date     | 5/21/2004 | User4 |
| By       | RA        | User5 |

| Item | Qty | Type | P/N            | Title                           | Detail                           | Ref(m) |
|------|-----|------|----------------|---------------------------------|----------------------------------|--------|
| Top  |     | CAT  | UTX3KWA        | UHF TV XMTR ANALOG              | 470 MHz TO 810 MHz               |        |
| 1    | 1   | PS   | BPU3KW         | BP FITER 3 KW BAND IV           | COM-TECH FC4E110C                |        |
| 2    | 1   | PS   | 851026         | FAN AC 208 2000 CFM EXHAUSE     | MULTIFAN VOSTERMANS 4VF1042A     |        |
| 3    | 1   | PS   | AC8100         | AC WIREMOLD 19 RACK MTG         | 1 X 4 OUTLETS 6 FT CORD          |        |
| 4    | 1   | CAT  | MODULATOR CAV5 | MODULATOR/DRIVER 5 W            | UHF ELECTRONICA ITALY            |        |
| 5    | 1   | CAT  | ADP500         | DISPLAY PANEL, ANALOG           | SEL SW AND METER                 |        |
| 6    | 1   | CAT  | DRV100DC-2     | DRIVER ASSEMBLY                 | 31 VDC WITH 1 U250LD             |        |
| 7    | 3   | PL   | MFA1KW         | 1 KW MAIN FRAME                 | UHF/VHF ASSEMBLIES               |        |
| 8    | 6   | PS   | AC2008         | 2 KW 31 VDC PWR SUPPLY          | UNI-PWR TRS6000-406              |        |
| 9    | 2   | PL   | AC2009         | 6KW 3EA PWR SUPPLY MAIN FRAME   | UNIPOWER RRS2U                   |        |
| 10   | 1   | CAT  | S10            | SPLITTER HOUSING UPTO 10 -WAY   | MULTI-USE 10-WAY BNC I/O         |        |
| 11   | 1   | PL   | R40RU-HAM      | XMTR RACK 40 RU                 | HAMMOND MFG                      |        |
| 12   | 1   | PS   | AC4302         | AC CORD GRIP                    | 0.98 OD CABLE 1.3 HOLE MTG       |        |
| 13   | 12  | PS   | AC6303         | AC INLET CORD 5/6 AWG           | SO CABLE                         |        |
| 14   | 1   | CAT  | PAS10          | PA SEL SW FOR ADP500            | 10 POLE INPUT 1 OUTPUT           |        |
| 15   | 1   | CAT  | FP-6           | FUSE PANEL UTX3KWA              | INC FUSE, SHUNT, SHIELD          |        |
| 16   | 1   | CAT  | AUX5K          | AUX PANEL 5KW                   | USED ON 3, 4, 5 KW XMTRS         |        |
| 17   | 1   | CAT  | UC3KW-40DD     | UHF COMBINER 3 KW W/SAMPLE PORT | 6-WAY STAR N TO 1 5-8 EIT FLANGE |        |







**VI — SCHEMATICS AND PARTS LIST**

**B. ACDIS3 — Parts List**

Printed 9/7/2004

AC DISTRIBUTION  
 3-PHASE BREAKER PANEL

|          |           |       |
|----------|-----------|-------|
| Type     | PL        | User1 |
| Revision | A         | User2 |
| Status   | U         | User3 |
| Date     | 6/28/2004 | User4 |
| By       | RA        | User5 |

| Item | Qty | Type | P/N     | Title                       | Detail                         | Ref(m) |
|------|-----|------|---------|-----------------------------|--------------------------------|--------|
| Top  |     | PL   | ACDIS3  | AC DISTRIBUTION             | 3-PHASE BREAKER PANEL          |        |
| 2    | 1   | PS   | AC4302  | AC CORD GRIP                | 0.98 OD CABLE 1.3 HOLE MTG     |        |
| 3    | 1   | PS   | AC32075 | AC BKR 3-PHASE 208 V 75 AMP | W/TRIP COLI                    |        |
| 5    | 7   | PS   | AC3220  | AC CKT BRKR                 | 20 AMP 2-POLE 220 V            |        |
| 6    | 1   | PS   | MF9318  | FRONT PANEL ACDIS3          | AC DISTRIBUTION                |        |
| 7    | 1   | PS   | MF9287  | ACDIS3, 4, AND 5 CHASSIS    |                                |        |
| 8    | 2   | PS   | AC4120  | AC POWER SOCKET 7 PIN       | BULGIN PX093/07/S              |        |
| 9    | 2   | PS   | AC4110  | AC POWER PLUG 7 PIN         | BULGIN PXA911/07/P             |        |
| 10   | 1   | PS   | MF9288  | TOP, COVER BREAKER PANEL    |                                |        |
| 11   | 1   | PS   | 630001  | INDICATOR LITE              | RED 220 VAC 1/2W               |        |
| 12   | 3   | PS   | AC4113  | AC PWR INLET HEAVY DUTY     | 16A 220 VAC 3 WIRE             |        |
| 13   | 3   | PS   | AC4111  | AC POWER PLUG 220AC 16A     | POWER INLET SCHURTER 4300.0922 |        |
| 14   | 1   | PS   | AC5106  | AC PANEL MTG OUTLET         | 2 POS "GANGED"                 |        |
| 15   | 1   | PS   | MF9329A | PLATE                       | 220 AC LINE CONN               |        |
| 16   | 1   | PS   | AC8000  | AC POWER DISTRIBUTION BLOCK | 3 POLE 840 A 600 VAC           |        |



VI — SCHEMATICS AND PARTS LIST  
 C. DRV100DC-2 — Schematic

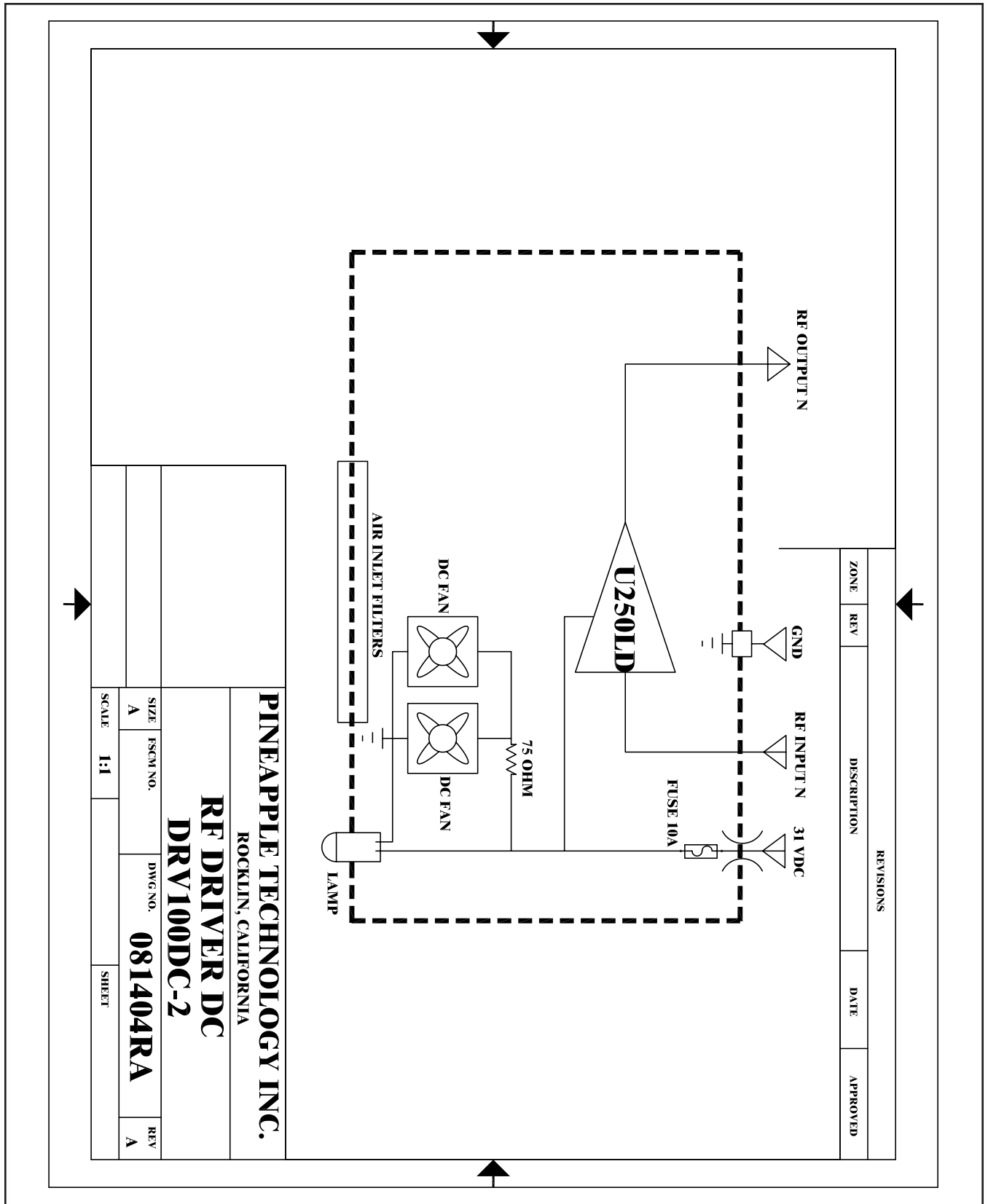



**VI — SCHEMATICS AND PARTS LIST**

**C. DRV100DC-2 — Parts List**

Printed 9/7/2004

DRIVER ASSEMBLY  
 31 VDC WITH 1 U250LD

|          |          |       |
|----------|----------|-------|
| Type     | CAT      | User1 |
| Revision | A        | User2 |
| Status   | U        | User3 |
| Date     | 6/7/2004 | User4 |
| By       | RA       | User5 |

| Item  | Qty | Type | P/N        | Title                 | Detail                       | Ref(m) |
|-------|-----|------|------------|-----------------------|------------------------------|--------|
| ■ Top |     | CAT  | DRV100DC-2 | DRIVER ASSEMBLY       | 31 VDC WITH 1 U250LD         |        |
| — 1   | 1   | PS   | 631001     | INDICATOR LAMP LED    | GREEN 24 VDC 1/2 IN MTG HOLE |        |
| — 2   | 1   | PS   | MF9337     | PANEL, FRONT          | DRV100DC                     |        |
| — 3   | 1   | PS   | MF9338A    | CHASSIS               | DRV100DC                     |        |
| — 4   | 1   | PS   | MF9339A    | DIVIDER AIR FLOW      | DRV100DC                     |        |
| — 5   | 1   | PS   | MF9340A    | TOP COVER             | DRV100DC                     |        |
| — 6   | 2   | PS   | 990201     | FILTER & FINGER GUARD | 80X25mm FAN 30 PPI           |        |
| — 7   | 2   | PS   | 851005     | FAN DC 24 V 80X25mm   | COMAIR-ROTRON                |        |
| — 8   | 1   | PS   | 27047N     | FT CAP 47NF DC        | 1/4-20 HW MTG THRU PANEL     |        |
| ■ 9   | 1   | CAT  | U250LD     | UHF TV 300 W P        | 470-810 MHz                  |        |
| — 10  | 1   | PS   | 140012     | RES AXIAL TH 2 WATT   | 75 OHM METAL OXIDE           |        |
| — 11  | 1   | PS   | 140010     | RES AXIAL 2 W         | 10 OHM                       |        |



VI — SCHEMATICS AND PARTS LIST

D. MFA1KW

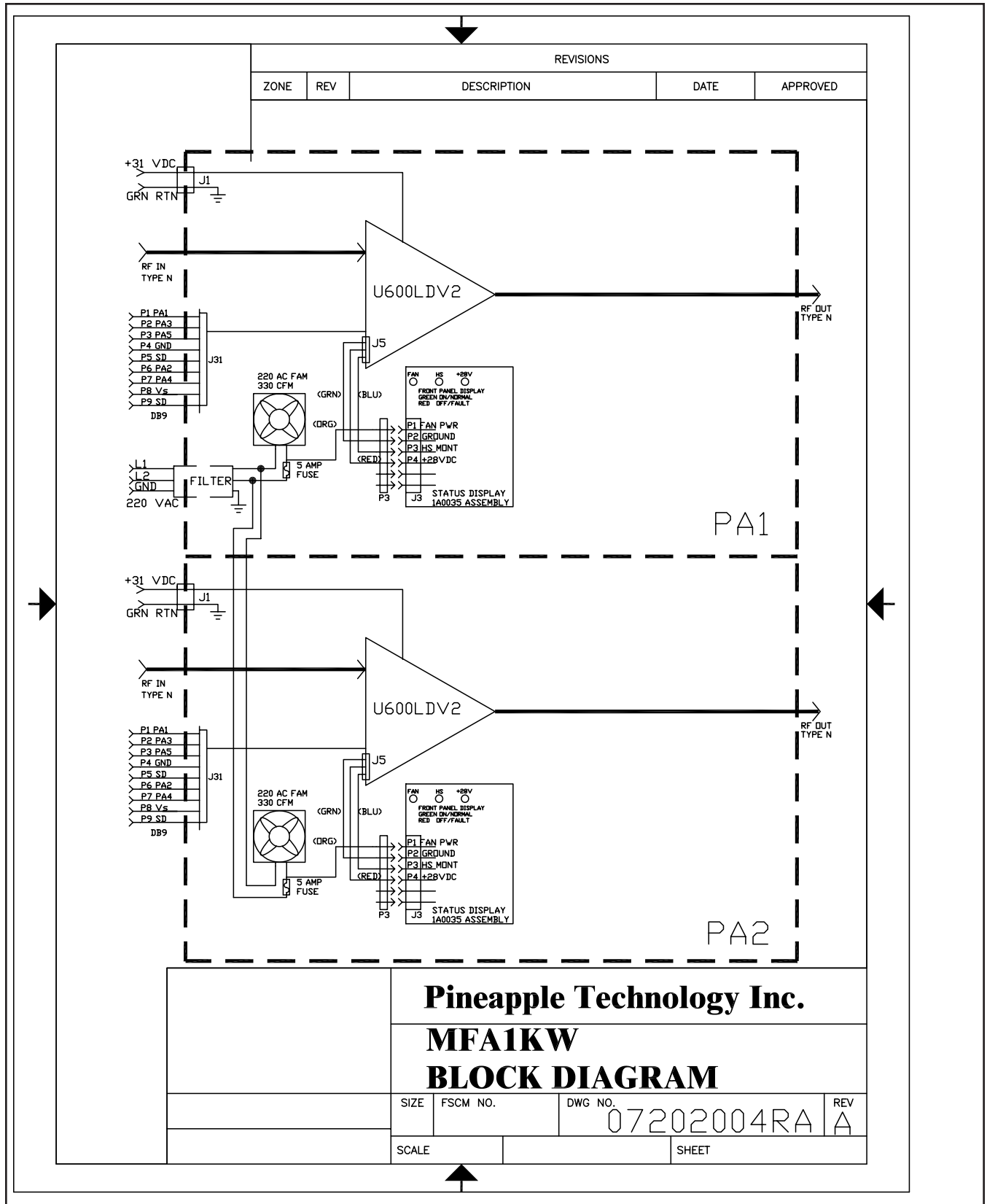



**VI — SCHEMATICS AND PARTS LIST**

**D. MFA1KW — Parts List**

Printed 8/16/2004

1 KW MAIN FRAME  
 UHF/VHF ASSEMBLIES

|          |           |       |
|----------|-----------|-------|
| Type     | PL        | User1 |
| Revision | A         | User2 |
| Status   | U         | User3 |
| Date     | 1/24/2000 | User4 |
| By       | RA        | User5 |

| Item | Qty | Type | P/N           | Title                      | Detail                        | Ref(m) |
|------|-----|------|---------------|----------------------------|-------------------------------|--------|
| Top  |     | PL   | MFA1KW        | 1 KW MAIN FRAME            | UHF/VHF ASSEMBLIES            |        |
| 1    | 1   | PS   | MF9100E       | MAIN CHASSIS               | MFA1KW                        |        |
| 2    | 1   | PS   | MF9101        | DIVIDER, PLENUM            | MFA1KW                        |        |
| 3    | 1   | PS   | MF9102C       | DIVIDER, FAN               | MFA1KW                        |        |
| 5    | 1   | PS   | MF9104        | COVER, TOP                 | MFA1KW                        |        |
| 10   | 4   | PS   | MF9139        | SLED GUIDE                 | U600LP & MFA1KW               |        |
| 11   | 1   | PS   | MF9123D       | FRONT PANEL, PAINTED       | MFA1KW                        |        |
| 14   | 2   | PS   | 990199        | FILTER, AIR DRY            | FF-5 MFA/PS FP                |        |
| 16   | 2   | PS   | MF9127        | MTG BRACKET, MOLEX FEMALE  | MFA1KW                        |        |
| 17   | 6   | PS   | 480472        | MOLEX CRIMP TERM MFA1KW    | MOLEX MFG 39-00-0041          |        |
| 18   | 2   | PS   | 480400        | MOLEX PLUG 6 TERM MFA1KW   | MOLEX 15-06-0065 MINI-FIT BMI |        |
| 19   | 2   | PS   | 460150        | FUSE HOLDER PANEL MTG      | 3AG TYPE QC CON               |        |
| 20   | 2   | PL   | 1A0035        | PA STATUS BOARD            | PC9061A                       |        |
| 22   | 4   | PS   | INHOUSE_LABOR | PTI LABOR                  |                               |        |
| 23   | 2   | PL   | U600LDV2      | 600W UHF AMPLIFIER MODULE  | USED WITH MFA1KW ASSEMBLY     |        |
| 24   | 2   | PS   | MF9308        | FAN FINGER GUARD           | MFA1KW & U600LPA              |        |
| 25   | 2   | PS   | MF9310        | AC FAN INLET HOLDER        | MFA1KW                        |        |
| 27   | 2   | PS   | MF9258        | BRACKET FILTER MTG PAINTED | U600LPA & MFA1KW              |        |
| 28   | 1   | PS   | MF9197B       | DIVIDER PA                 | MFA1KW                        |        |
| 29   | 2   | PS   | 851025        | FAN, AC 220 V              | COMAIR ROTRON TN3A2           |        |
| 30   | 2   | PS   | AC5110        | AC FAN PLUG & CORD         | FEMALE PLUG 24 IN CORD        |        |



VI — SCHEMATICS AND PARTS LIST

D. MFA1KW

1. 1A0035 STATUS BOARD

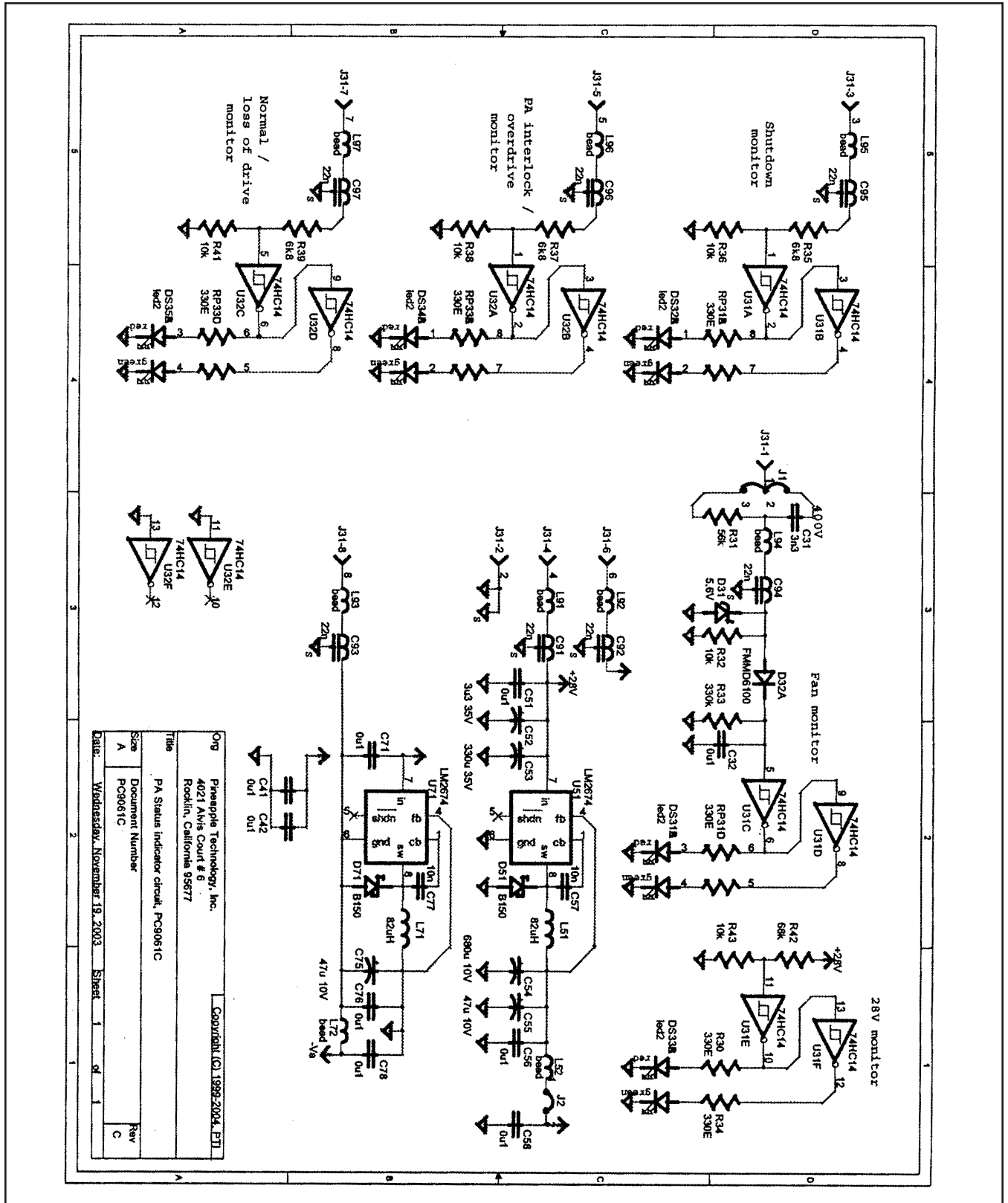

|       |                                                  |                              |
|-------|--------------------------------------------------|------------------------------|
| Org   | Pineapple Technology, Inc.                       | Copyright (C) 1995-2004, PTI |
| Title | 4021 Akvis Court # 6<br>Rodick, California 95677 |                              |
| Size  | PA Status indicator circuit, PC9061C             |                              |
| A     | Document Number                                  |                              |
|       | PC9061C                                          |                              |
| Date: | Wednesday, November 19, 2003                     | Sheet 1 of 1                 |
|       |                                                  | Rev C                        |



**VI — SCHEMATICS AND PARTS LIST**

**D. MFA1KW**

**1. 1A0035 PARTS LIST**

Printed 8/16/2004

PA STATUS BOARD  
 PC9061A

|          |          |       |
|----------|----------|-------|
| Type     | PL       | User1 |
| Revision | B        | User2 |
| Status   | U        | User3 |
| Date     | 8/1/2002 | User4 |
| By       | RA       | User5 |

| Item | Qty | Type | P/N    | Title                       | Detail                      | Ref(m)                           |
|------|-----|------|--------|-----------------------------|-----------------------------|----------------------------------|
| Top  |     | PL   | 1A0035 | PA STATUS BOARD             | PC9061A                     |                                  |
| 1    | 2   | CAT  | 114330 | RES ARRAY, SMT              | 330 OHMS                    | RP31, RP32                       |
| 2    | 5   | PS   | 115103 | RES CHIP 0805               | 10K OHM SMT 0805            | R32,36,38,4<br>1,43              |
| 3    | 1   | PS   | 115334 | RES CHIP 0805               | 330 K OHM SMT               | R33                              |
| 4    | 1   | PS   | 115563 | RES CHIP 0805               | 56K OHM 0805 SM             | R31                              |
| 5    | 3   | PS   | 115682 | RES CHIP 0805               | 6.8 K OHM SMT               | R35,37,39                        |
| 6    | 6   | PS   | 21X005 | CAP CHIP 0805               | 100NF 10% XTR 0805<br>CASE  | C32,41,42,5<br>1,56,58,71,       |
| 7    | 1   | PS   | 21X008 | CHIP CAP 0805               | 10NF 50 V 0805 SM           | C57,                             |
| 8    | 1   | PS   | 240109 | CAP TH<br>POLYPROPYLENE     | 3N3 600 WVDC<br>.033UF      | C31                              |
| 9    | 1   | PS   | 240110 | CAP TAN SMD                 | 3.3 UFD 35 V                | C52                              |
| 10   | 1   | PS   | 240111 | CAP TAN SMD                 | 47 UF 10 V TAN              | C55,                             |
| 11   | 1   | PS   | 241300 | CAP RADIAL TH               | 330 UF 35 VDC               | C53                              |
| 12   | 1   | PS   | 241301 | CAP RADIAL TH               | 680 UF 10 V<br>ELECTROLYTIC | C54                              |
| 13   | 6   | PS   | 27022N | FT CAP 22N SM               | AVX OR MURRATA<br>PART      | C91, 92, 94,<br>95, 96,<br>97,93 |
| 14   | 1   | PS   | 480500 | CON MICRO-FIT<br>HEADER 3.0 | 8 PIN PC MTG                | J31                              |
| 15   | 1   | PS   | 520230 | SEMI DIODE<br>SHOTTKY       | 1.5 A 60 VDC D-64           | D51                              |
| 16   | 1   | PS   | 520275 | SEMI, DIODE DUAL            | FMMD6100                    | D32                              |
| 17   | 2   | PS   | 530350 | HEX SCHMITH TRIG            | 74HD14                      | U31, U32                         |
| 18   | 1   | PS   | 538150 | IC SWITCHER SIMPLE          | SO8 PAK                     | U51,                             |
| 19   | 5   | PS   | 630200 | IND LED DUAL COLOR          | RED/GREEN T1-3/4<br>CLR     | DS31,32,33,<br>34,35             |
| 20   | 8   | PS   | 750001 | FERRITE BEAD SMT            | 0805 EMI FERRITE<br>BEAD    | L52<br>,91,92,94,95<br>,96,97,72 |
| 21   | 1   | PS   | 830510 | IND, W/W                    | 82 UH .58A PWR SMD          | L51,                             |
| 22   | 2   | PS   | PC9061 | PA STAU BRD                 | FR4 060 1/1 CBR             |                                  |
| 23   | 2   | PS   | 115331 | RES CHIP 0805               | 330 OHM SMT                 | R30,34                           |
| 24   | 1   | PS   | 520120 | SEMI ZENER                  | 5.6 V MELF                  | D31                              |
| 25   | 1   | PS   | 115683 | RES CHIP 0805               | 68K SM                      | R42                              |



VI — SCHEMATICS AND PARTS LIST  
 E. U600LDV-2 — Block Diagram

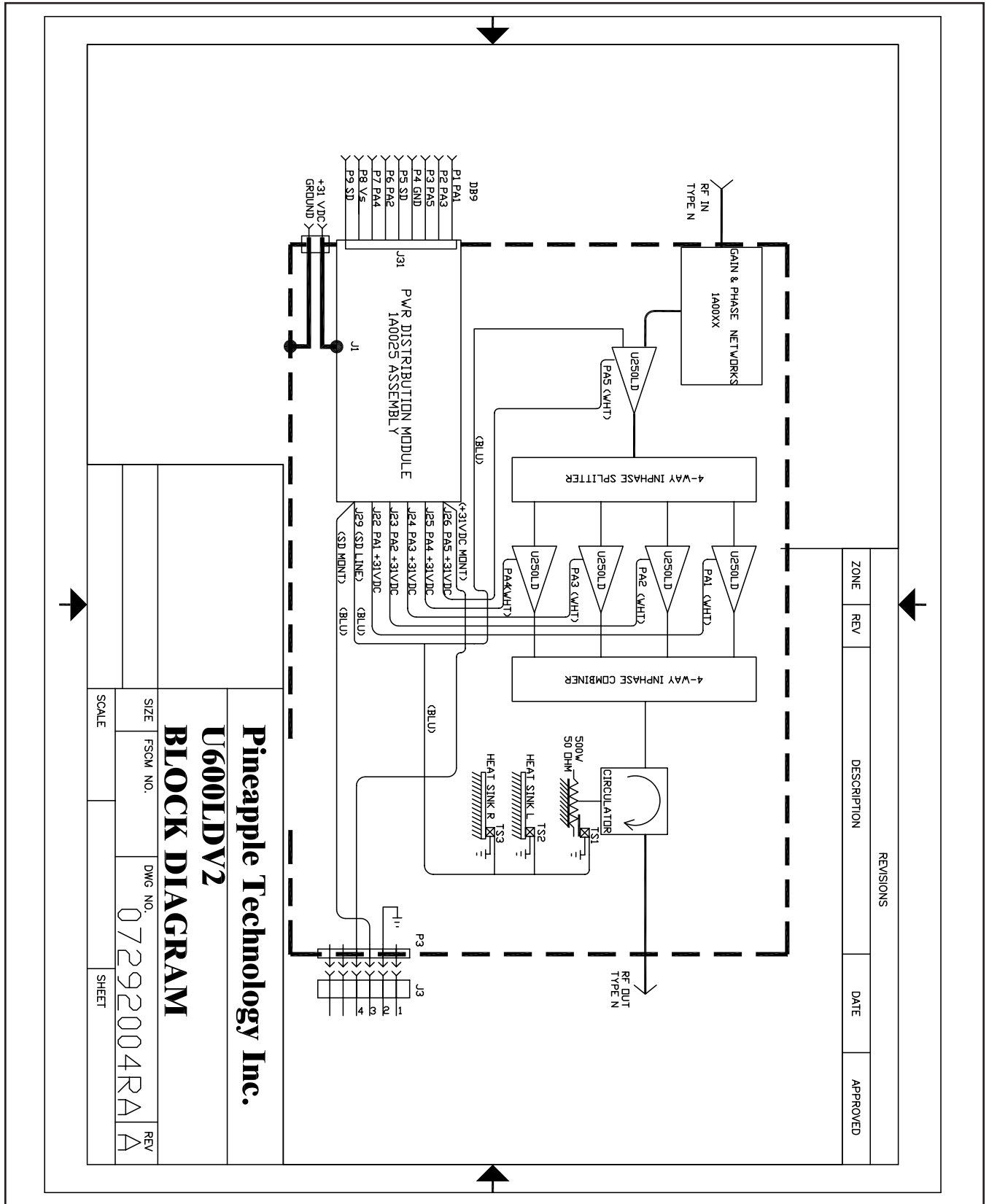

**Pineapple Technology Inc.**  
**U600LDV2**  
**BLOCK DIAGRAM**

| REVISIONS |     | DATE        | APPROVED |
|-----------|-----|-------------|----------|
| ZONE      | REV | DESCRIPTION |          |
|           |     |             |          |

|       |          |            |     |
|-------|----------|------------|-----|
| SIZE  | FSCM NO. | DWG NO.    | REV |
|       |          | 07292004RA | A   |
| SCALE | SHEET    |            |     |





**VI — SCHEMATICS AND PARTS LIST**

**E. U600LDV-2 — Parts List**

Printed 8/16/2004

600W UHF AMPLIFIER MODULE  
 USED WITH MFA1KW ASSEMBLY

|          |           |       |
|----------|-----------|-------|
| Type     | PL        | User1 |
| Revision | A         | User2 |
| Status   | U         | User3 |
| Date     | 1/21/2004 | User4 |
| By       | RA        | User5 |

| Item | Qty | Type | P/N         | Title                       | Detail                        | Ref(m) |
|------|-----|------|-------------|-----------------------------|-------------------------------|--------|
| Top  |     | PL   | U600LDV2    | 600W UHF AMPLIFIER MODULE   | USED WITH MFA1KW ASSEMBLY     |        |
| 1    | 1   | PS   | U4002-1T    | UHF CIR 3T DITOM            | DF4002 470-540 MHz            |        |
| 2    | 1   | PS   | MF9126C     | MOLEX BRACKET MTG PLATE     | U600LD ALL                    |        |
| 3    | 3   | PS   | 310010      | SW THERMAL                  | 140 DEG F N/C                 |        |
| 4    | 1   | PS   | MF9160C     | HEAR SINK U600LD            | RIGHT SIDE                    |        |
| 5    | 1   | PS   | MF9159G     | HEAT SINK U600LD            | LEFT SIDE                     |        |
| 6    | 1   | PL   | 1A0018      | PHASE & GAIN MATCHING UHF   | U500/U600LD ASS'Y             |        |
| 7    | 1   | PS   | MF9118A     | BASE PLATE, US200           | AI 1/2 IN                     |        |
| 8    | 1   | PS   | MF9137      | SLED                        | U500L AL                      |        |
| 9    | 1   | PS   | 454001      | HANDLE, REAR                | BLK NYLON                     |        |
| 10   | 1   | PS   | PC9033_34   | PC BRD JUMPER               | U600LD RGR 4003 060           |        |
| 11   | 2   | PS   | PC9023B     | PCB COMB/SPLTR              | R-4003 060 1/1                |        |
| 12   | 4   | PS   | 180040-100R | RES PWR 40 W                | 100 OHM RES                   |        |
| 13   | 2   | PS   | 180150-100R | RES PWR 150 W               | 100 OHM RES                   |        |
| 14   | 1   | PS   | 180250-50T  | RES PWR 250 W               | 50 OHM TERM                   |        |
| 15   | 2   | PS   | 440101      | HW CS STANDOFF              | 1.0 x .375; Male/Female; 1032 |        |
| 16   | 1   | PS   | MF9203 B1   | PLATE, ISO/MONT BRD         | SM 09 AL W/MTG                |        |
| 17   | 1   | PS   | MF9202B1    | COVER, REAR U600LD          | SM 09 AL                      |        |
| 18   | 1   | PS   | MF9206AMU   | Shield, PC9050A             | PCB SHIELD MONITOR/ISO BRD    |        |
| 19   | 1   | PL   | 1A0025      | DC ISO/MONITOR CKT          | REPLACED CB99                 |        |
| 20   | 3   | PS   | MF9075A     | CIR MOUNTING PLT            | O.09 ALUM                     |        |
| 21   | 1   | PS   | 452001      | HWRD TERM FEED THRU BLK     | 5 PIN; #10 STUD; 10-16 AWG    |        |
| 22   | 1   | PS   | 452050      | HWR TERM BLK COVER          | 5 PIN COVER W/MTG HWRD        |        |
| 23   | 1   | PS   | 480401      | MOLEX RECEPTACLE U600LD     | MOLEX 15-06-0061              |        |
| 24   | 3   | PS   | 480473      | MOLEX CRIMP TERMINAL U600LD | MOLEX 39-00-0039 FEMALE       |        |
| 25   | 1   | PL   | CA5001      | COAX CABLE ASSEMBLY         | RG142 TO N PM FM 4 HOLE FLG   |        |



**VI — SCHEMATICS AND PARTS LIST**  
**E. U600LDV-2 — Parts List (Cont.)**

600W UHF AMPLIFIER MODULE  
 USED WITH MFA1KW ASSEMBLY

U600LDV2  
 Rev A  
 Printed 8/16/2004

| Item | Qty | Type | P/N           | Title                | Detail                         | Ref(m) |
|------|-----|------|---------------|----------------------|--------------------------------|--------|
| ■ 26 | 1   | PL   | CA5030        | COAX CABLE ASSEMBLY  | ANDREWS ETS1 TO N PANEL FLG MT |        |
| — 27 | 1   | PS   | 491600        | N FEMALE BULK CRIMP  | REAR MNT W/ "O" RING           |        |
| ■ 28 | 5   | CAT  | U250LD        | UHF TV 300 W P       | 470-810 MHz                    |        |
| — 29 | 6   | PS   | INHOUSE_LABOR | PTI LABOR            |                                |        |
| — 30 | 1   | PS   | MF9309        | REAR PANEL WITH SILK | 090 AL ALODYNE                 |        |



**VI — SCHEMATICS AND PARTS LIST**

**E. U600LDV-2**

**1. U250LD — Schematic**

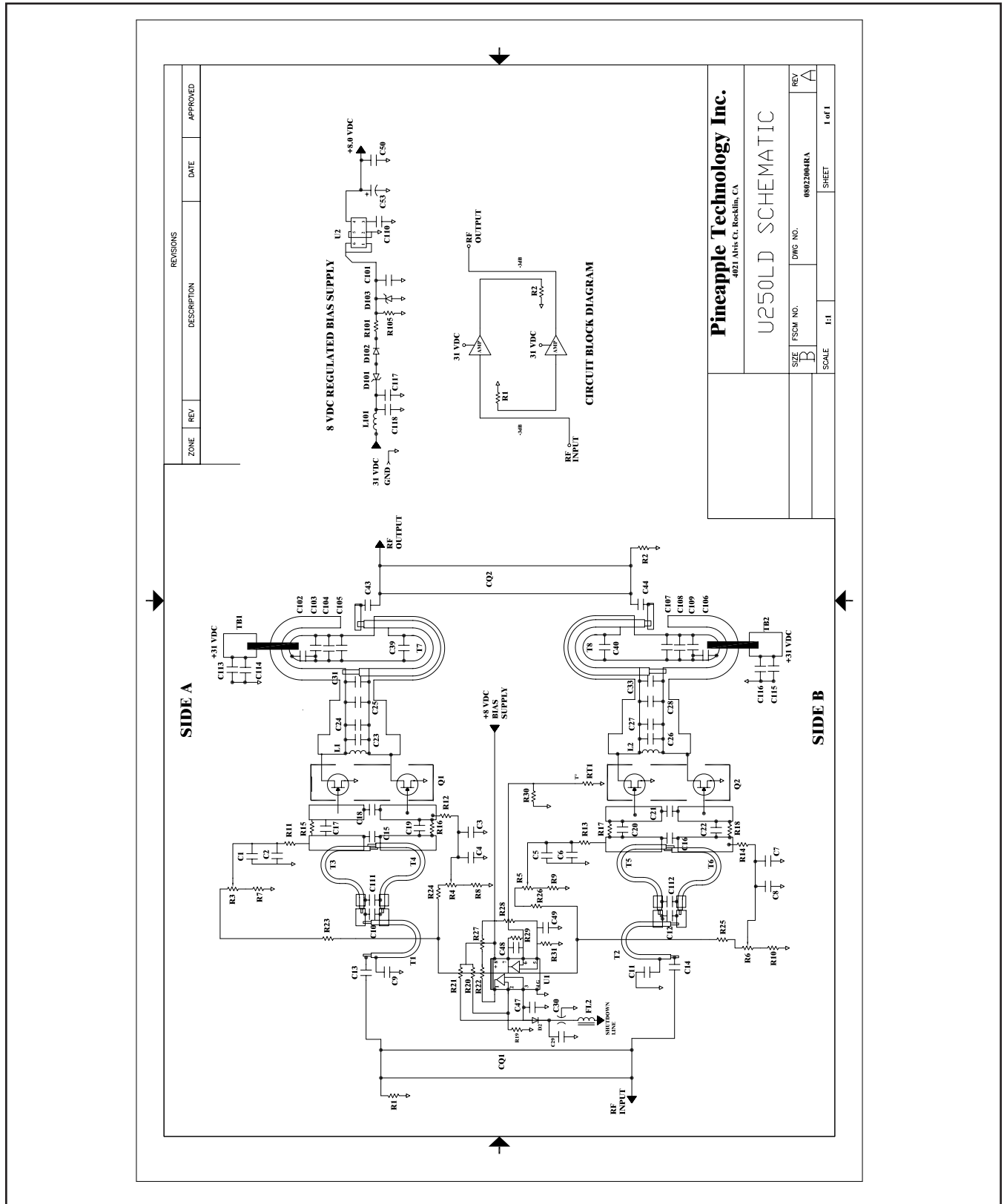



VI — SCHEMATICS AND PARTS LIST

E. U600LDV-2

1. U250LD — Layout Drawing

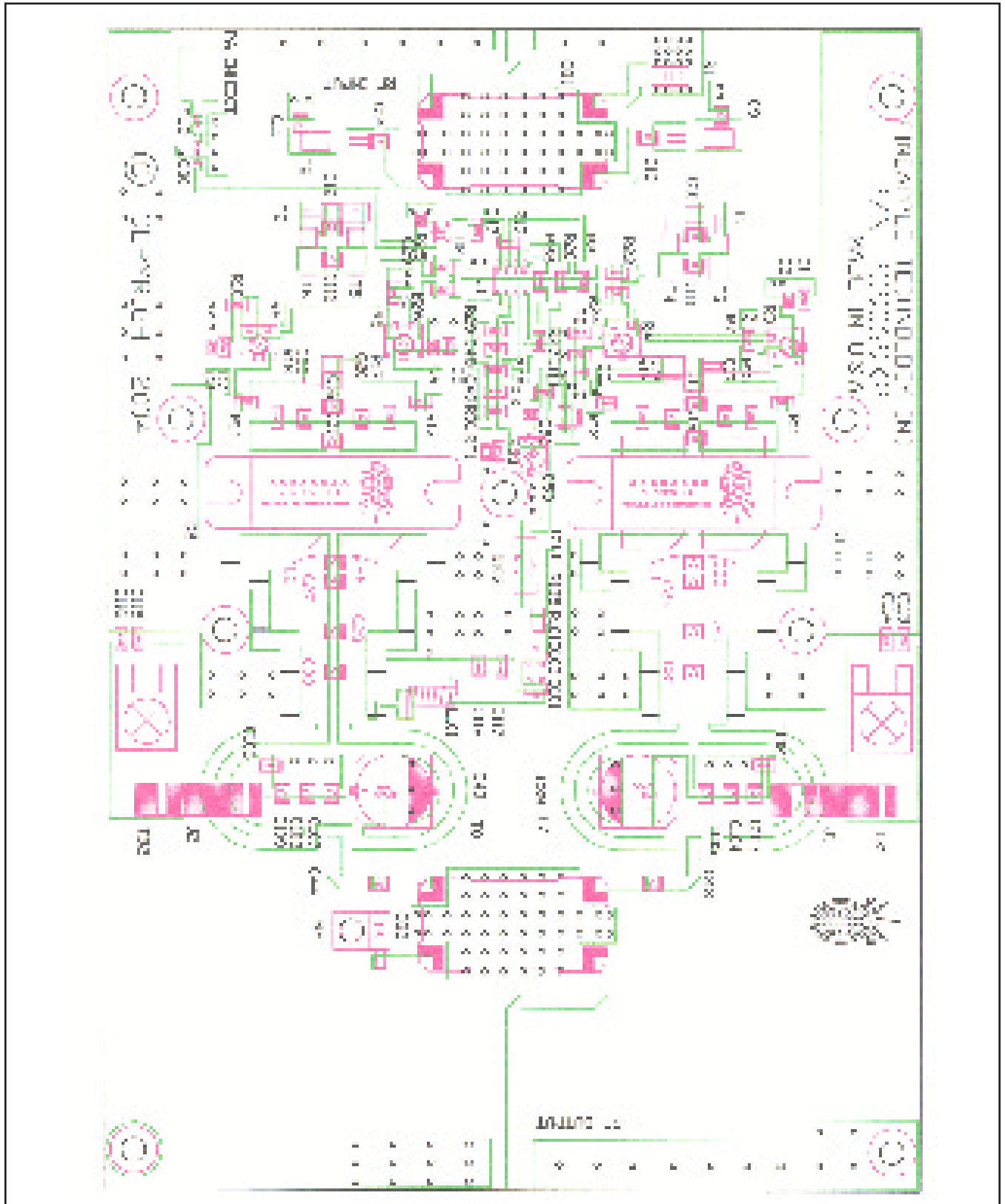



**VI — SCHEMATICS AND PARTS LIST**

**E. U600LDV-2**

**1. U250LD — Parts List**

Printed 8/16/2004

UHF TV 300 W P  
 470-810 MHz

|          |           |       |
|----------|-----------|-------|
| Type     | CAT       | User1 |
| Revision | A         | User2 |
| Status   | U         | User3 |
| Date     | 11/5/2003 | User4 |
| By       | RA        | User5 |

| Item | Qty | Type | P/N        | Title                 | Detail              | Ref(m)                                        |
|------|-----|------|------------|-----------------------|---------------------|-----------------------------------------------|
| Top  |     | CAT  | U250LD     | UHF TV 300 W P        | 470-810 MHz         |                                               |
| 1    | 1   | PS   | PC9069C    | U300LD 470-860 MHz TV | FR4 060 1/1         |                                               |
| 2    | 2   | PS   | 530737     | LDMOS PWR FET UHF TV  | BLF861A PHILIPS     | Q1,2                                          |
| 4    | 1   | PS   | 560107     | DUAL OP AMP 8-SOIC    | TLV272IDR           | U1                                            |
| 6    | 1   | PS   | 117444     | THERMISTOR            | 33K OHM             | RT1                                           |
| 7    | 1   | PS   | 180030-50T | RES PWR 30 W SMT      | RFP-30-50T RFPC     | R1                                            |
| 8    | 1   | PS   | 180010-50T | RES PWR 10 W          | 50 OHM TERM         | R2 ((NO LOAD))                                |
| 9    | 4   | PS   | 17L202     | RES VAR SMT           | 2K OHM POT          | R3,4,5,6                                      |
| 10   | 4   | PS   | 116202     | RES CHIP 1206         | 2K OHM SMT          | R7,8,9,10                                     |
| 11   | 10  | PS   | 116103     | RES CHIP 1/8 W        | 10 K OHM SM 1206    | R11,12,13,14,19,20,22,30,31,105               |
| 12   | 4   | PS   | 116010     | RES CHIP 1206         | 10 OHM SM           | R15,16,17,18                                  |
| 13   | 1   | PS   | 116102     | RES CHIP 1/8          | 1 K OHM SM 1206     | R21,                                          |
| 14   | 2   | PS   | 116000     | RES CHIP 1206         | 0.0 OHMS SM         | R27,28,                                       |
| 15   | 1   | PS   | 116822     | RES CHIP 1206         | 8.2K OHM 1/8 W SMT  | R29                                           |
| 19   | 14  | PS   | 21Y042     | CAP CHIP              | 0.1 UF 50 V 1206    | C1,3,5,7,47,48,49,101,105,109,110,113,115,117 |
| 20   | 11  | PS   | 21X001     | CAP CHIP 0805         | 100 PF 50V SMD      | C2,4,6,8,29,50,102,106,114,116,118            |
| 21   | 6   | PS   | 263301     | CAP CHIP ATC          | 300 PF B CASE       | C9,11,103,107,111,112                         |
| 22   | 2   | PS   | 2631R8     | CHIP CAP ATC          | 1.8PFBCASE          | C10,12                                        |
| 23   | 4   | PS   | 263180     | CAP CHIP ATC          | 18 PF B CASE        | C15,16,                                       |
| 24   | 2   | PS   | 263200     | CAP CHIP ATC          | 18-20 PF B CASE     | C18,21 ((NO LOAD))                            |
| 26   | 1   | PS   | 27022N     | FT CAP 22N SM         | AVX OR MURRATA PART | C30                                           |
| 29   | 2   | PS   | 241220     | CAP RADIAL SM         | 220 UF 50 V HA      | C39,40                                        |



**VI — SCHEMATICS AND PARTS LIST**

**E. U600LDV-2**

**1. U250LD — Parts List (Cont.)**

UHF TV 300 W P  
 470-810 MHz

U250LD  
 Rev A  
 Printed 8/16/2004

| Item | Qty | Type | P/N          | Title                 | Detail                 | Ref(m)                           |
|------|-----|------|--------------|-----------------------|------------------------|----------------------------------|
| 30   | 1   | PS   | 750001       | FERRITE BEAD SMT      | 0805 EMI FERRITE BEAD  | FL2                              |
| 31   | 1   | PS   | 520129       | SEMI DIODE GP         | 1N914 SM SOT-23        | D2,102,                          |
| 33   | 2   | PS   | 451070       | HW PWR TAP            | 6-32 STL KEYSTONE 8191 | TB1,TB2                          |
| 34   | 3   | PS   | 520118       | SEMI ZENER            | 14V MINI 3P MA3140CT   | D101,103,                        |
| 35   | 1   | PS   | 560116       | 8VDC SMT REGULATOR    | TK11280CMCL            | U2                               |
| 36   | 1   | PS   | 241010       | CAP RADIAL SM         | 10UF 16V ALUM ELEC     | C53                              |
| 37   | 6   | PS   | 2638R2       | ATC CHIP CAP          | 8.2 PF B CASE          | C23,24,26,27,((23,26 NO LOAD))   |
| 38   | 4   | PS   | 2636R8       | CAP CHIP ATC          | 6.8 PF B CASE          | C25,28,31,33                     |
| 39   | 10  | PS   | 263101       | CAP CHIP ATC          | 100 PF B CASE          | C13,14,17,19,20,22,43,44,104,108 |
| 40   | 1   | PS   | 830430       | IND CHIP W-W          | AIR COIL 43.0 NH SMT   | L101                             |
| 41   | 5   | PS   | 116471       | RES CHIP 1206         | 470 OHM 1/8 W SMT      | R101, R23,24,25,26               |
| 42   | 2   | PS   | PAC0001      | MATCHING XFMR         | RG316 CUT & TRIM       | T1,2                             |
| 43   | 2   | PS   | PAC0002      | MATCHING XFMR COXIAL  | UT90-25 CUT & TRIM     | T7,8                             |
| 44   | 4   | PS   | PAC0003      | MATCHING XFMR COAXIAL | UT47-25                | T3,4,5,6                         |
| 45   | 2   | PS   | 391600       | HYBRID COUPLER        |                        | CQ1, CQ2                         |
| 46   | 2   | PS   | DIRECT_LABOR | LABOR                 | INHOUSE LABOR/TEST     |                                  |



VI — SCHEMATICS AND PARTS LIST

E. U600LDV-2

2. 1A0025 Power Distribution Monitor

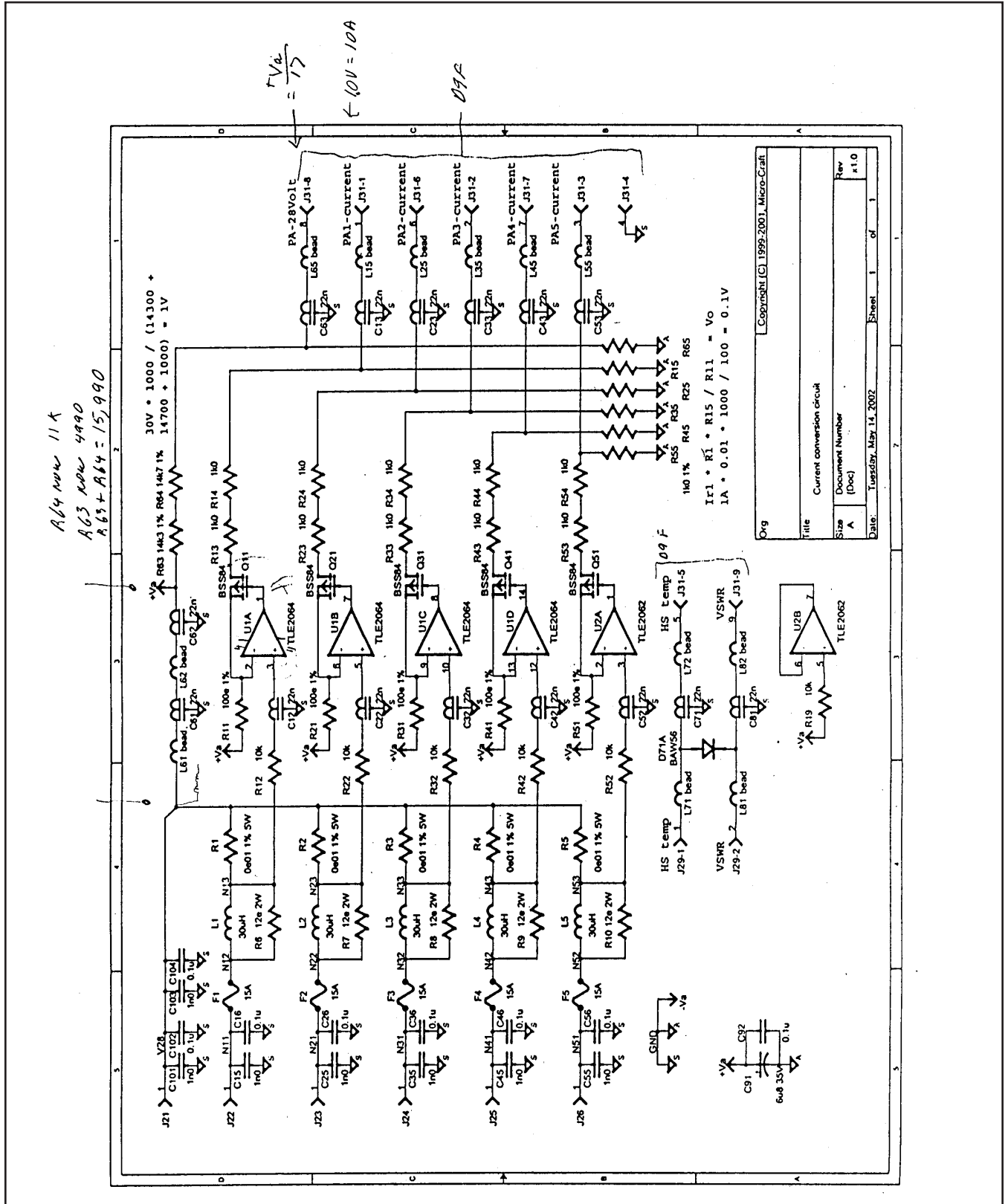



**VI — SCHEMATICS AND PARTS LIST**

**E. U600LDV-2**

**2. 1A0025 — Parts List**

Printed 8/16/2004

DC ISO/MONITOR CKT  
 REPLACED CB99

|          |            |       |
|----------|------------|-------|
| Type     | PL         | User1 |
| Revision | B          | User2 |
| Status   | U          | User3 |
| Date     | 11/29/2001 | User4 |
| By       | RA         | User5 |

| Item | Qty | Type | P/N     | Title                      | Detail                    | Ref(m)                                                                                                   |
|------|-----|------|---------|----------------------------|---------------------------|----------------------------------------------------------------------------------------------------------|
| Top  |     | PL   | 1A0025  | DC ISO/MONITOR CKT         | REPLACED CB99             |                                                                                                          |
| 1    | 1   | PS   | PC9050C | PCB DC ISO/MONT<br>BRD     | FR4 060                   |                                                                                                          |
| 2    | 1   | PS   | 560101  | OP-AMP QUAD PAK            | TLE2064AID TI             | U1                                                                                                       |
| 3    | 1   | PS   | 560102  | OP-AMP DUAL PAK            | 8-SOIC                    | U2                                                                                                       |
| 4    | 21  | PS   | 27022N  | FT CAP 22N SM              | AVX OR MURRATA<br>PART    | C11, 12,<br>13, 21, 22,<br>23, 31, 32,<br>33, 41, 42,<br>43, 51, 52,<br>53, 61, 63,<br>71, 73, 81,<br>83 |
| 5    | 1   | PS   | 240102  | CAP SM TAN                 | 6.8 UF 35 V C CASE        | C91                                                                                                      |
| 6    | 1   | PS   | 21Y022  | CAP SM 1206                | 47 NF 50 V                | C92                                                                                                      |
| 7    | 5   | PS   | 472015  | FUSE PICO II EPOXY         | 15 A 32 VDC               | F1, 2, 3, 4,<br>5                                                                                        |
| 8    | 1   | PS   | 481250  | CON DB9 SUB RT<br>ANGLE FM | METAL CASE<br>AMP7457814  | J31                                                                                                      |
| 9    | 5   | PL   | 1A0011  | TOROID IND                 | 10 T #14 ON N40           | L1, 2, 3, 4,<br>5                                                                                        |
| 10   | 5   | PS   | 590010  | XISTOR FET BSS84           | BSS84ZXCT                 | Q11, 21,<br>31, 41, 51                                                                                   |
| 11   | 5   | PS   | 150R01  | RES 5 WATT AXIAL           | 0.01 OHM 1.0 %            | R1, 2, 3, 4,<br>5                                                                                        |
| 12   | 5   | PS   | 140010  | RES AXIAL 2 W              | 10 OHM                    | R6, 7, 8, 9,<br>10                                                                                       |
| 13   | 5   | PS   | 1151000 | RES CHIP 0805              | 100 OHM 1% 0805           | R11, 21,<br>31, 41, 51                                                                                   |
| 14   | 6   | PS   | 1151002 | RES CHIP 0805              | 10 K OHM 1% 0805<br>CASE  | R12, 19,<br>22, 32, 42,<br>52                                                                            |
| 15   | 10  | PS   | 1151001 | RES CHIP 0805              | 1 K OHM 1 %               | R13, 14,<br>15, 23, 24,<br>25, 33, 34,<br>35, 43, 44,<br>45, 53, 54,<br>55, 65                           |
| 17   | 5   | PS   | 451070  | HW PWR TAP                 | 6-32 STL KEYSTONE<br>8191 | J22, 23, 24,<br>25, 26                                                                                   |
| 18   | 1   | PS   | 480300  | CON 2 PIN HEADER           | AMP A23837-ND             | P29                                                                                                      |
| 19   | 1   | PS   | 480310  | CON 2 PIN PC POST          | AMP 640456-2              | J29                                                                                                      |





**VI — SCHEMATICS AND PARTS LIST**

**E. U600LDV-2**

**2. 1A0025 — Parts List (Cont.)**

DC ISO/MONITOR CKT  
 REPLACED CB99

1A0025  
 Rev B  
 Printed 8/16/2004

| Item | Qty | Type | P/N     | Title            | Detail                  | Ref(m)                               |
|------|-----|------|---------|------------------|-------------------------|--------------------------------------|
| 20   | 12  | PS   | 750001  | FERRITE BEAD SMT | 0805 EMI FERRITE BEAD   | L15,25,35,45,55,61,62,65,71,72,81,82 |
| 21   | 9   | PS   | 21X005  | CAP CHIP 0805    | 100NF 10% XTR 0805 CASE | C16,26,36,46,56,102,104,106,108      |
| 22   | 9   | PS   | 21X006  | CHIP CAP 0805    | 1000 PF 10% 0805 CASE   | C15,25,35,45,55,101,103,105,107      |
| 23   | 1   | PS   | 1154991 | RES CHIP 0805    | 4.99K OHM 1% 0805 CASE  | R63                                  |
| 24   | 1   | PS   | 115113  | RES CHIP 0805    | 11K OHM 1% 0805 CASE    | R64                                  |
| 25   | 1   | PS   | 520260  | DIODE SWITCH     | 80V 100MA MINI 3P       |                                      |



VI — SCHEMATICS AND PARTS LIST

E. U600LDV-2

3. 1A0018 Gain and Phase Matching

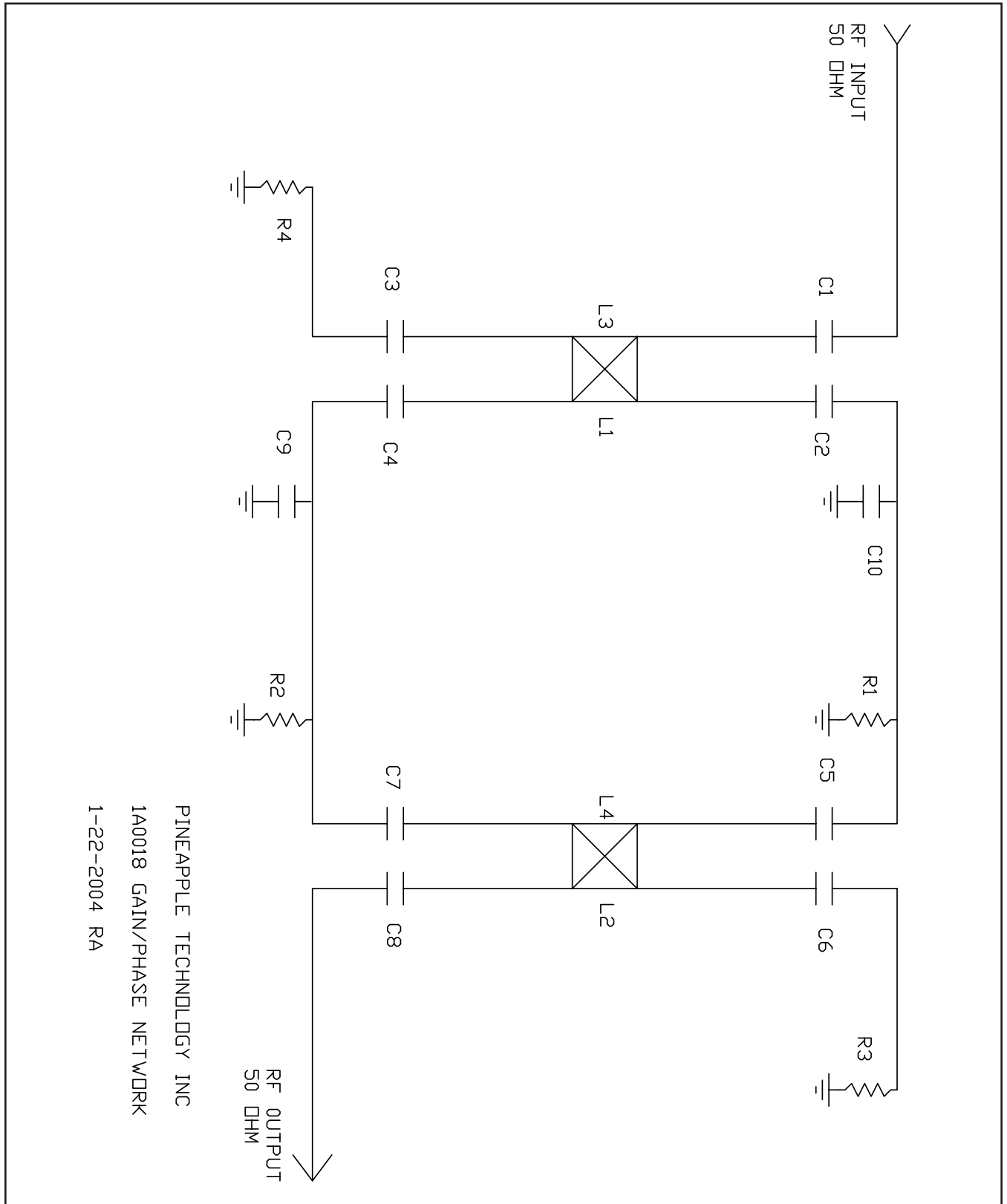

PINEAPPLE TECHNOLOGY INC  
1A0018 GAIN/PHASE NETWORK  
1-22-2004 RA



**VI — SCHEMATICS AND PARTS LIST**

**E. U600LDV-2**

**3. 1A0018 — Parts List**

Printed 8/16/2004

PHASE & GAIN MATCHING UHF  
 U500/U600LD ASS'Y

|          |           |       |
|----------|-----------|-------|
| Type     | PL        | User1 |
| Revision | A         | User2 |
| Status   | U         | User3 |
| Date     | 1/14/2001 | User4 |
| By       | RA        | User5 |

| Item | Qty | Type | P/N          | Title                     | Detail                      | Ref(m)               |
|------|-----|------|--------------|---------------------------|-----------------------------|----------------------|
| Top  |     | PL   | 1A0018       | PHASE & GAIN MATCHING UHF | U500/U600LD ASS'Y           |                      |
| 1    | 2   | PS   | PC9031A      | PCB BB QUAD               | 4 LAYER RGR 4003<br>008/060 |                      |
| 2    | 4   | PS   | 822560       | IND CHIP                  | 56 NH 0805 SM               | L1,2,3,4             |
| 3    | 8   | PS   | 263390       | CAP CHIP                  | 39 PF B CASE ATC            | C1,2,3,4,5,<br>6,7,8 |
| 4    | 2   | PS   | 263100       | CAP CHIP ATC              | 10 PF B CASE                | C9,10                |
| 5    | .1  | PS   | DIRECT_LABOR | LABOR                     | INHOUSE<br>LABOR/TEST       |                      |
| 6    | 2   | PS   | 180010-50T   | RES PWR 10 W              | 50 OHM TERM                 | R3,4                 |
| 7    | 2   | PS   | 11Y681       | RES CHIP 1 W              | 680 OHM 2512 CASE<br>SMT    | R1,2                 |



**VI — SCHEMATICS AND PARTS LIST**  
**F. S10-6 IN PHASE SPLITTER — Parts List**

Printed 9/7/2004

SPLITTER HOUSING UPTO 10 -WAY  
 MULTI-USE 10-WAY BNC I/O

|          |          |       |
|----------|----------|-------|
| Type     | CAT      | User1 |
| Revision | A        | User2 |
| Status   | U        | User3 |
| Date     | 6/7/2004 | User4 |
| By       | RA       | User5 |

| Item | Qty | Type | P/N     | Title                            | Detail                       | Ref(m) |
|------|-----|------|---------|----------------------------------|------------------------------|--------|
| Top  |     | CAT  | S10     | SPLITTER HOUSING<br>UPTO 10 -WAY | MULTI-USE 10-WAY<br>BNC I/O  |        |
| 1    | 1   | PS   | MF9333A | FRONT PANEL S10<br>SPLITTER      | PAINTED                      |        |
| 3    | 1   | PS   | MF9334A | S10 TOP COVER                    | AL 0.063 THK GOLD<br>ALODYNE |        |
| 4    | 1   | PS   | MF9335A | CHASSIS                          | S10                          |        |
| 5    | 1   | PS   | MF9336A | REAR CONN PANEL                  | S10                          |        |



**VI — SCHEMATICS AND PARTS LIST**  
**G. COMBINER UC3KW-DC40**

No servicable parts.



VI — SCHEMATICS AND PARTS LIST

H. PAS10 — Schematic

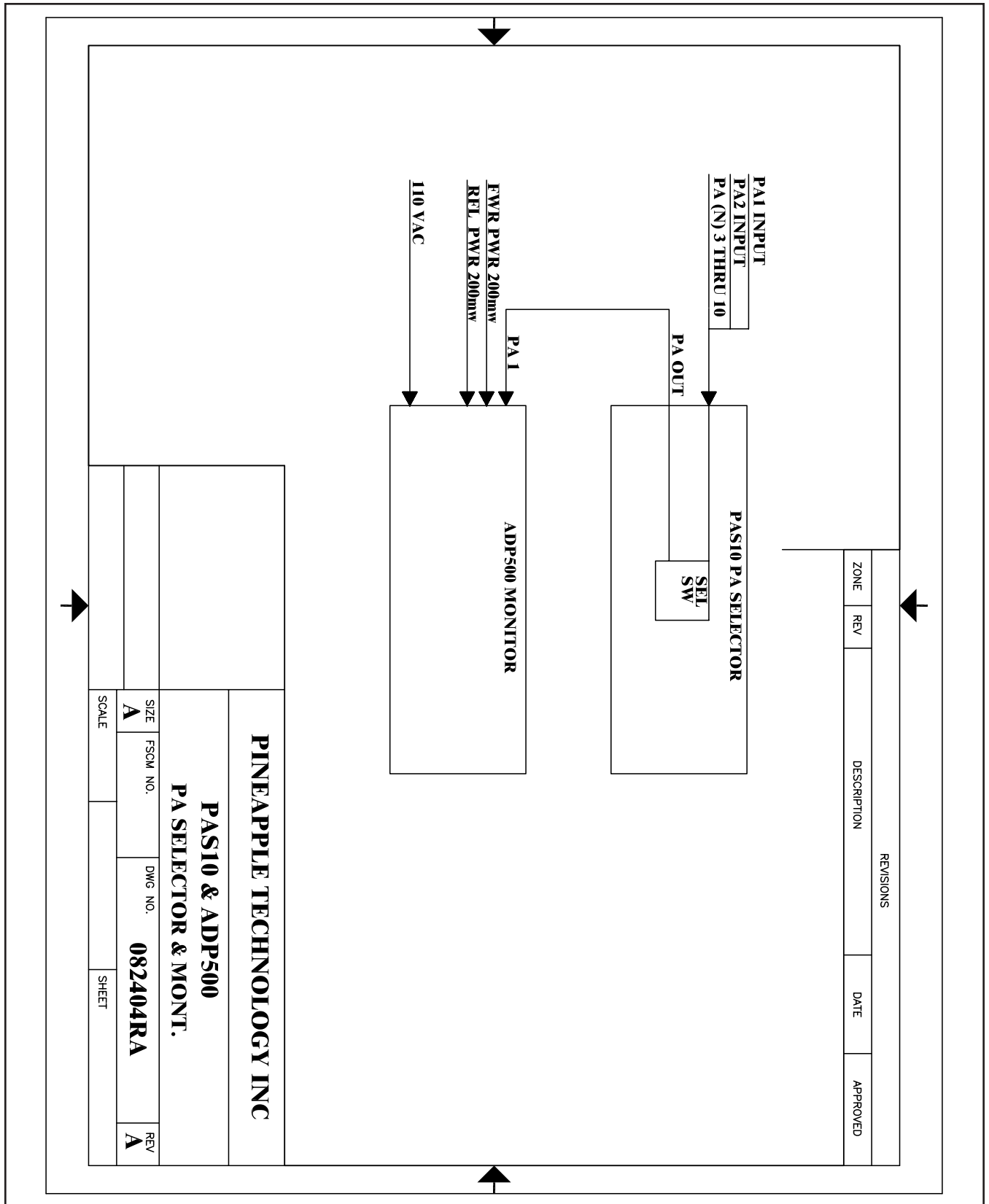



**VI — SCHEMATICS AND PARTS LIST**

**H. PAS10 MONITOR — Parts List**

Printed 9/7/2004

PA SEL SW FOR ADP500  
 10 POLE INPUT 1 OUTPUT

|          |           |       |
|----------|-----------|-------|
| Type     | CAT       | User1 |
| Revision | A         | User2 |
| Status   | U         | User3 |
| Date     | 6/22/2004 | User4 |
| By       | RA        | User5 |

| Item | Qty | Type | P/N      | Title                    | Detail                   | Ref(m) |
|------|-----|------|----------|--------------------------|--------------------------|--------|
| Top  |     | CAT  | PAS10    | PA SEL SW FOR ADP500     | 10 POLE INPUT 1 OUTPUT   |        |
| 1    | 1   | PS   | PC9501   | PA SELECTER SWITCH       | 10 POLE ADP500           |        |
| 2    | 1   | PS   | 483010   | SW 10 POLE               | ADP500 PA SELECTOR PAS10 |        |
| 3    | 1   | PS   | 481250   | CON DB9 SUB RT ANGLE FM  | METAL CASE AMP7457814    |        |
| 4    | 5   | PS   | 481260   | CON DB9 2 SECTION RT ANG | PCB MTG 0.9 SPACING      |        |
| 5    | 1   | PS   | MF9342X1 | PLATE, FRONT PAS10       | W/ PAINT & SILKSCREEN    |        |
| 6    | 1   | PS   | MF9343X1 | CHASSIS, PAS10           | W/ ALODINE & SILKSCREEN  |        |
| 7    | 1   | PS   | MF9344X1 | COVER, TOP PAS10         | W/ ALODINE & SILKSCREEN  |        |



VI — SCHEMATICS AND PARTS LIST  
 H. ADP500 MONITOR

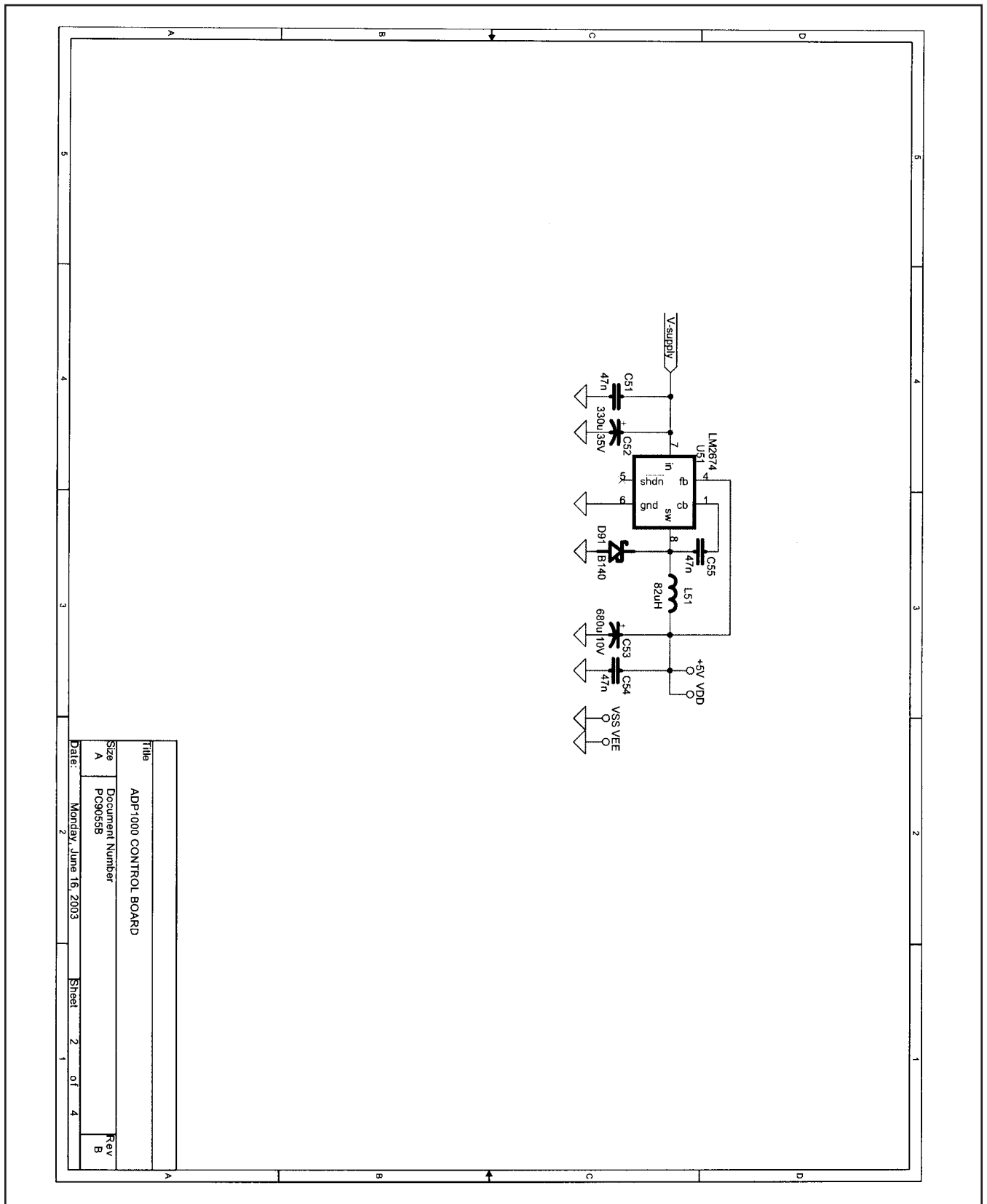

|       |                 |                        |        |
|-------|-----------------|------------------------|--------|
| Title |                 | ADP-1000 CONTROL BOARD |        |
| Size  | Document Number |                        |        |
| A     | PC9055B         |                        |        |
| Date: |                 | Monday, June 16, 2003  |        |
|       |                 | Sheet                  | 2 of 4 |
|       |                 | Rev                    | B      |



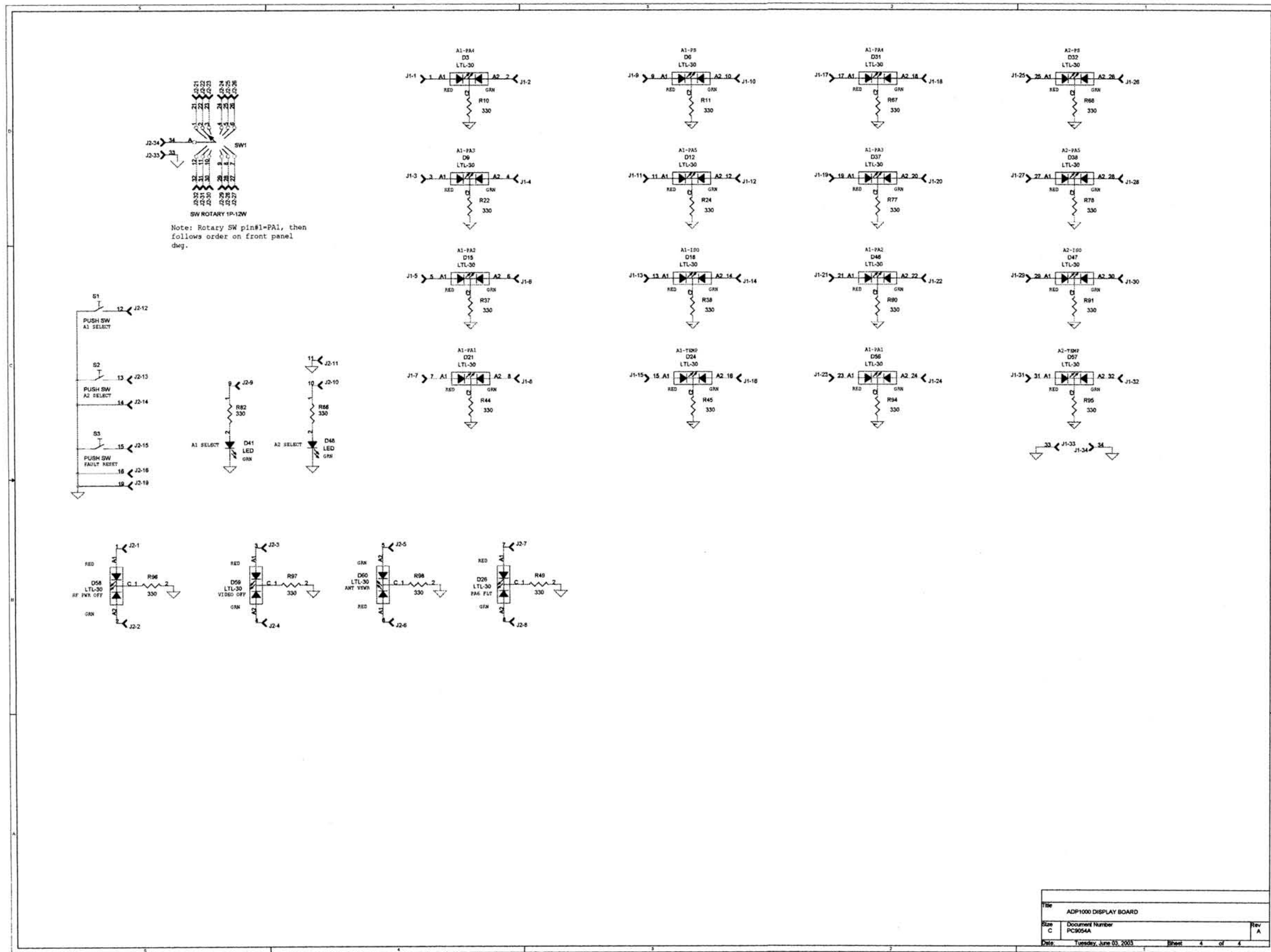

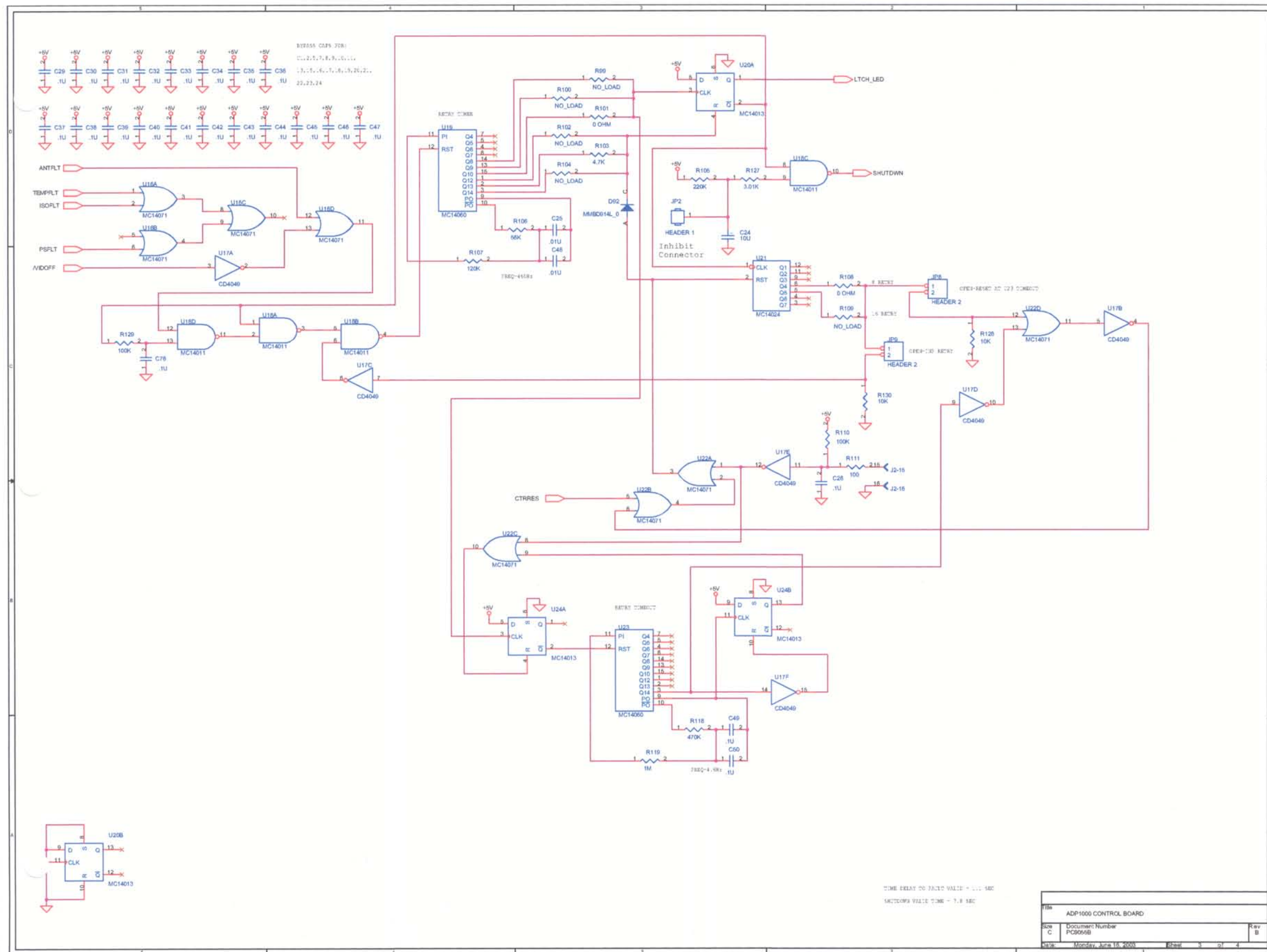



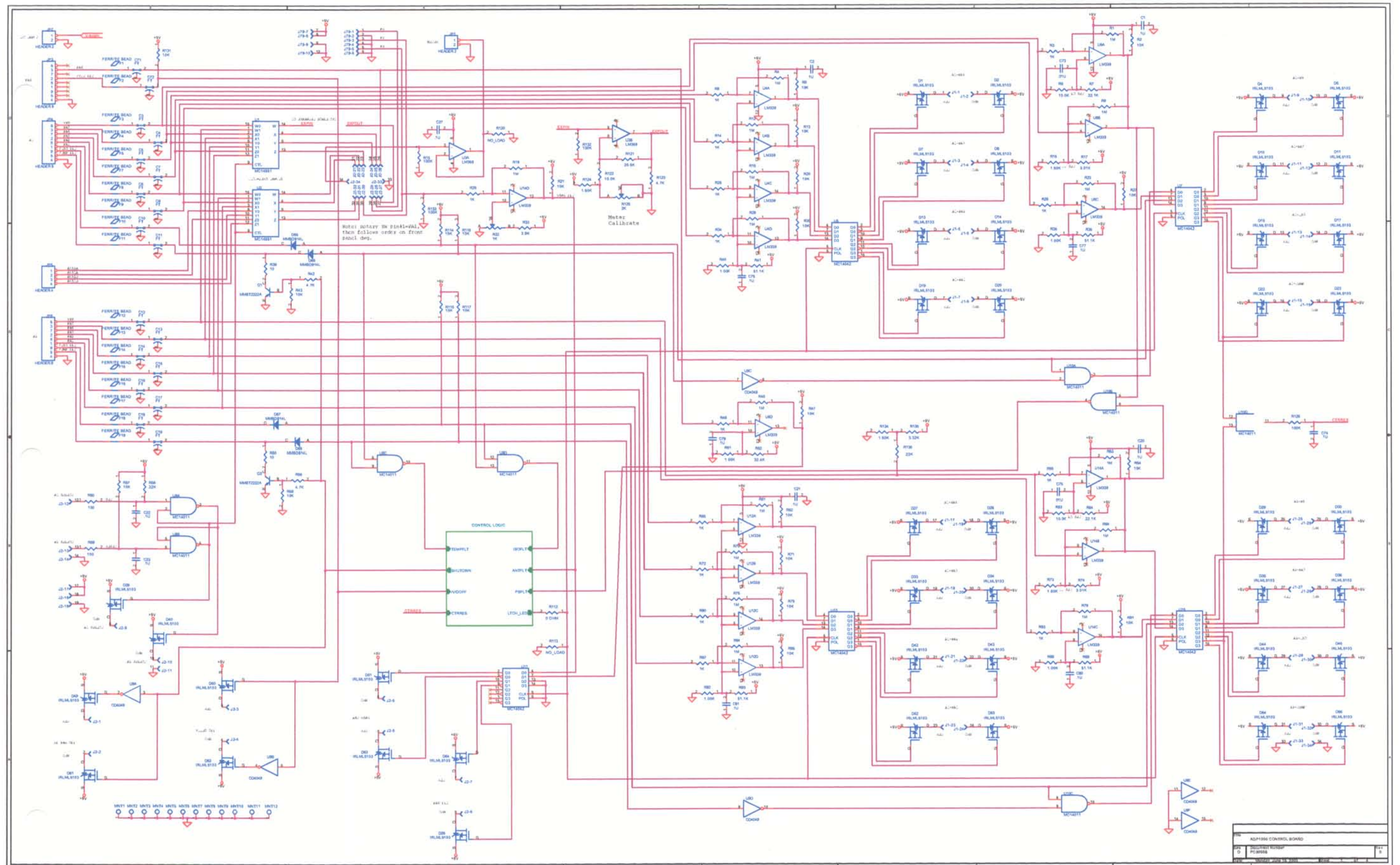



**VI — SCHEMATICS AND PARTS LIST**  
**H. ADP500 MONITOR — Parts List**

Printed 9/7/2004

DISPLAY PANEL, ANALOG  
 SEL SW AND METER

|          |           |       |
|----------|-----------|-------|
| Type     | CAT       | User1 |
| Revision | A         | User2 |
| Status   | U         | User3 |
| Date     | 9/15/2002 | User4 |
| By       | RA        | User5 |

| Item | Qty | Type | P/N    | Title                      | Detail                     | Ref(m) |
|------|-----|------|--------|----------------------------|----------------------------|--------|
| Top  |     | CAT  | ADP500 | DISPLAY PANEL,<br>ANALOG   | SEL SW AND METER           |        |
| 1    | 1   | PL   | 1A0029 | ADP1000 LOGIC PCB          | LOGIC BRD PARTS            |        |
| 2    | 1   | PL   | 1A0030 | ADP1000 FP PCB             | FP PCB AND PARTS           |        |
| 3    | 1   | PS   | 471306 | FUSE 3AG                   | 6 AMP                      |        |
| 4    | 1   | PS   | 460150 | FUSE HOLDER PANEL<br>MTG   | 3AG TYPE QC CON            |        |
| 5    | 1   | PS   | 484001 | SW, ON/OFF ROCKER<br>AC    | CW IND.<br>NAA-211-B121-00 |        |
| 6    | 1   | PS   | 660103 | METER, 2 VOLTS FS          | SELCO 39M-0-2VDC           |        |
| 7    | 1   | PL   | 1A0027 | PWR MONITOR CK             | PC9052B CBR                |        |
| 8    | 1   | PS   | PS2527 | POWER SUPPLY<br>OPEN/FRAME | 110/220 VAC 27 V 25<br>W   |        |



**VI — SCHEMATICS AND PARTS LIST**

**H. ADP500 MONITOR**

**1. 1A0027 — Parts List**

Printed 8/16/2004

PWR MONITOR CK  
 PC9052B CBR

|          |            |       |
|----------|------------|-------|
| Type     | PL         | User1 |
| Revision | B          | User2 |
| Status   | U          | User3 |
| Date     | 12/15/2001 | User4 |
| By       | RA         | User5 |

| Item | Qty | Type | P/N       | Title              | Detail                          | Ref(m)                                                         |
|------|-----|------|-----------|--------------------|---------------------------------|----------------------------------------------------------------|
| Top  |     | PL   | 1A0027    | PWR MONITOR CK     | PC9052B CBR                     |                                                                |
| 1    | 1   | PS   | PC9052B   | PWR MONITOR BRD    | FR4 060 1/1 2 SIDES<br>CBR CKTS | PC BOARD                                                       |
| 2    | 3   | PS   | 115103    | RES CHIP 0805      | 10K OHM SMT 0805                | R9, 33                                                         |
| 3    | 2   | PS   | 560108    | SEMI OP-AMP        | DUAL OP AMP                     | U1, 2                                                          |
| 6    | 1   | PS   | 115271    | RES CHIP 0805      | 270 OHM 0805                    | R28                                                            |
| 7    | 1   | PS   | 115272    | RES CHIP 0805      | 2.7K OHM 0805 CASE              | R23, 24,<br>26, 27                                             |
| 8    | 1   | PS   | 115273    | RES CHIP 0805      | 27K OHM 0805 CASE               | R8                                                             |
| 10   | 6   | PS   | 115102    | RES CHIP 0805      | 1K OHM 0805 CASE                | R5, 7, 31,<br>45                                               |
| 11   | 5   | PS   | 115104    | RES CHIP 0805      | 100K OHM 0805 SMT               | R4, 6, 29,<br>30, 44                                           |
| 12   | 3   | PS   | 115105    | RES CHIP 0805      | 1M OHM 0805 CASE<br>SMT         | R3, 22, 43                                                     |
| 13   | 3   | PS   | 115000    | RES CHIP 0805      | 0 OHM 0805 CASE<br>SMT          | R2, 42, 21                                                     |
| 14   | 2   | PS   | 11Y510    | RES CHIP 1W        | 51 OHM 5% 2512<br>CASE          | R1, 41                                                         |
| 15   | 1   | PS   | 520300    | SEMI GP XSTR       | MMBT2222ALT1                    | Q1, Q2                                                         |
| 16   | 3   | PS   | 520201    | SEMI DIODE SHOTKEY | 70V Surf Mnt                    | D1, 2, 3                                                       |
| 17   | 2   | PS   | 822560-WW | IND CHIP W/W       | 56 NH WW HI-Q OSC<br>CKT        | L1, 2                                                          |
| 19   | 1   | PS   | 485001    | HEADER 10 PIN TH   | AMP 0.1 CTR<br>103308-1         | J3                                                             |
| 20   | 2   | PS   | 21Y001    | CHIP CAP 1206      | 39 PF 50 V NPO                  | C1, 41                                                         |
| 21   | 14  | PS   | 21X007    | CHIP CAP 0805      | 47NF 50WVDC X7R                 | C3, 21, 23,<br>24, 26, 27,<br>29, 43, 51,<br>52, 53, 55,<br>56 |
| 23   | 2   | PS   | 21Y004    | CHIP CAP 1206      | 2.2 NF 50V NPO                  | C22, 25                                                        |
| 24   | 2   | PS   | 240105    | CAP SM CASE C      | 10 UF 10 V TAN                  | C54, 57                                                        |
| 25   | 3   | PS   | 17M102    | RES VARI 12 TURN   | 1K OHMS SM                      | R10, 34, 47                                                    |
| 26   | 1   | PS   | 17M103    | RES VARI 12 TURN   | 10K OHMS SM                     | R32                                                            |
| 27   | 1   | PS   | 115151    | RES CHIP 0805      | 150 OHM 1% 0805<br>SMT          | R25                                                            |
| 28   | 1   | PS   | 115931    | RES CHIP 0805      | 930 OHM 1% 0805<br>SMT          | R46                                                            |
| 29   | 2   | PS   | 240106    | CAP SM CASE 1206   | 2.2 UF 16V TAN                  | C2, 42                                                         |

PINEAPPLE TECHNOLOGY, INC.  
 4021 ALVIS COURT, #6, ROCKLIN, CA 95677  
 916-315-8338 Fax 916-315-8118

1A0027  
 Page 1 of 2



**VI — SCHEMATICS AND PARTS LIST**

**H. ADP500 MONITOR**

1. 1A0027 — Parts List (Cont.)

PWR MONITOR CK  
 PC9052B CBR

1A0027  
 Rev B  
 Printed 8/16/2004

| Item | Qty | Type | P/N    | Title                 | Detail                     | Ref(m) |
|------|-----|------|--------|-----------------------|----------------------------|--------|
| 30   | 1   | PS   | 240107 | CAP SM 1206 CASE      | 4.7UF 16 V TAN 1206 CASE   | C28    |
| 31   | 1   | PS   | 115362 | RES CHIP 0805         | 3.6K OHM 0805 SMT          | R11    |
| 32   | 2   | PS   | 996300 | INDUCTOR 1T + TORROID | #22 SOLID WIRE AND TORROID | L5, 6  |



**VI — SCHEMATICS AND PARTS LIST**

**H. ADP500 MONITOR**

**2. 1A0029 — Parts List**

Printed 8/16/2004

ADP1000 LOGIC PCB  
 LOGIC BRD PARTS

|          |          |       |
|----------|----------|-------|
| Type     | PL       | User1 |
| Revision | A        | User2 |
| Status   | U        | User3 |
| Date     | 1/5/2002 | User4 |
| By       | RA       | User5 |

| Item | Qty | Type | P/N      | Title                       | Detail                     | Ref(m)                                                                                                                                                            |
|------|-----|------|----------|-----------------------------|----------------------------|-------------------------------------------------------------------------------------------------------------------------------------------------------------------|
| Top  |     | PL   | 1A0029   | ADP1000 LOGIC PCB           | LOGIC BRD PARTS            |                                                                                                                                                                   |
| 1    | 1   | PS   | PC9055   | ADP1000 LOGIC BOARD         | FR4 060 1/1 CBR            |                                                                                                                                                                   |
| 2    | 2   | PS   | 560320   | LOGIC IC MC14013            | DUAL D F/F SOT 14          | U20, 24                                                                                                                                                           |
| 3    | 3   | PS   | 560315   | LOGIC IC MC14011BD          | LOG CMOS GATE NAND QUAD    | U8, 10, 18                                                                                                                                                        |
| 4    | 5   | PS   | 560325   | LOGIC IC MC14042BD          | LOG CMOS LATCH QUAD TRAN   | U5, 7, 11, 13, 15                                                                                                                                                 |
| 5    | 2   | PS   | 560310   | LOGIC IC MC14060BD          | CTR/DRIVER IC SOT 16       | U19, 23                                                                                                                                                           |
| 6    | 2   | PS   | 539100   | IC HEX INV BUFFER           | CD4049UBCM                 | U9, 17                                                                                                                                                            |
| 7    | 2   | PS   | 560330   | LOGIC IC MC14071BD          | LOG CMOS GATE OR QUAD SO14 | U16, 22                                                                                                                                                           |
| 8    | 4   | PS   | 539000   | IC DIF AMP QUAD             | LM339DR SO14               | U4, 6, 12, 14                                                                                                                                                     |
| 9    | 1   | PS   | 560108   | SEMI OP-AMP                 | DUAL OP AMP                | U3                                                                                                                                                                |
| 10   | 2   | PS   | 562500   | ANALOG MC14551BD            | MUX/DE-MUX 2 CHANNEL       | U1, U2                                                                                                                                                            |
| 11   | 1   | PS   | 538100   | IC SWITCHER/REG LM2674M-5.0 | 28 V IN 5 VOLTS OUT 500MA  | U51                                                                                                                                                               |
| 12   | 1   | PS   | 539110   | LOGIC IC CD4024BM           | 7 STAGE COUNTER SO14       | U21                                                                                                                                                               |
| 13   | 2   | PS   | 11622R13 | RES CHIP 1206               | 22.1K OHM SMT              | R7, 64                                                                                                                                                            |
| 14   | 4   | PS   | 1155112  | RES 0805 CASE               | 51.1 K OHM 1%              | R36, 41, 89, 93                                                                                                                                                   |
| 15   | 1   | PS   | 1153242  | RES 0805 CASE               | 32.4 K OHM 1%              | R52                                                                                                                                                               |
| 16   | 2   | PS   | 520300   | SEMI GP XSTR                | MMBT2222ALT1               | Q1, Q2                                                                                                                                                            |
| 17   | 42  | PS   | 520272   | DIODE HEX FET P             | HEX FET SOT-3              | D1, 2, 4, 5, 7, 8, 10, 11, 13, 14, 16, 17, 19, 20, 22, 23, 25, 27, 28, 29, 30, 33, 34, 35, 36, 39, 40, 42, 43, 44, 45, 49, 50, 51, 52, 53, 54, 55, 61, 62, 63, 64 |
| 18   | 1   | PS   | 830510   | IND, W/W                    | 82 UH .58A PWR SMD         | L51                                                                                                                                                               |
| 19   | 4   | PS   | 520129   | SEMI DIODE GP               | 1N914 SM SOT-23            | D65, 66, 67, 68, 92                                                                                                                                               |



**VI — SCHEMATICS AND PARTS LIST**

**H. ADP500 MONITOR**

**2. 1A0029 — Parts List (Cont.)**

ADP1000 LOGIC PCB  
 LOGIC BRD PARTS

1A0029  
 Rev A  
 Printed 8/16/2004

| Item | Qty | Type | P/N     | Title              | Detail                          | Ref(m)                                                                                                                                        |
|------|-----|------|---------|--------------------|---------------------------------|-----------------------------------------------------------------------------------------------------------------------------------------------|
| 21   | 17  | PS   | 116105  | RES CHIP 1/8 W     | 1 M OHM SM 1206                 | R1, 4, 9, 12, 18, 19, 23, 29, 46, 53, 61, 66, 70, 75, 79, 84, 119                                                                             |
| 22   | 27  | PS   | 116103  | RES CHIP 1/8 W     | 10 K OHM SM 1206                | R2, 5, 6, 13, 20, 21, 27, 30, 43, 47, 54, 57, 59, 62, 63, 71, 76, 81, 85, 114, 115, 116, 117, 122, 128, 130, 131                              |
| 23   | 14  | PS   | 116102  | RES CHIP 1/8       | 1 K OHM SM 1206                 | R3, 8, 14, 25, 26, 28, 34, 35, 40, 48, 51, 55, 65, 72, 80, 83, 87, 88, 92, 125                                                                |
| 24   | 36  | PS   | 21Y042  | CAP CHIP           | 0.1 UF 50 V 1206                | C1, 2, 20, 21, 22, 23, 26, 27, 29, 30, 31, 31.33, 34, 35, 36, 37, 38, 39, 40, 41, 42, 43, 44, 45, 46, 47, 49, 50, 74, 76, 77, 78, 79, 80, 81, |
| 25   | 18  | PS   | 27022N  | FT CAP 22N SM      | AVX OR MURRATA PART             | C3, 4, 5, 7, 8, 9, 10, 11, 12, 13, 14, 15, 16, 17, 18, 19, 71, 72                                                                             |
| 26   | 18  | PS   | 750001  | FERRITE BEAD SMT   | 0805 EMI FERRITE BEAD           | F1, 2, 5, 4, 5, 7, 8, 9, 10, 11, 12, 13, 14, 15, 16, 17                                                                                       |
| 27   | 1   | PS   | 241310  | CAP RADIAL TH      | 680 UF 35 WVDC AL ELECTROLYTIC  | C52                                                                                                                                           |
| 28   | 1   | PS   | 241320  | CAP RADIAL TH      | 1200 UF 10 WVDC AL ELECTROLYTIC | C53                                                                                                                                           |
| 29   | 1   | PS   | 240200  | CAP SM 1206 CASE   | 10 UF 10 WVDC                   | C24                                                                                                                                           |
| 30   | 4   | PS   | 21Y041  | CAP CHIP           | 0.01 UF SM 1206                 | C25, 48, 73, 75                                                                                                                               |
| 31   | 3   | PS   | 21Y022  | CAP SM 1206        | 47 NF 50 V                      | C51, 54, 55                                                                                                                                   |
| 32   | 1   | PS   | 1163321 | RES CHIP 1206      | 3.32 K OHM 1%                   | R135                                                                                                                                          |
| 33   | 1   | PS   | 1162252 | RES CHIP 1206      | 25.5K OHM 1206 CASE             | R121                                                                                                                                          |
| 34   | 1   | PS   | 116474  | RES CHIP 1206      | 470K OHM 1/8 W                  | R118                                                                                                                                          |
| 35   | 1   | PS   | 116124  | RES CHIP 1206 CASE | 120 K OHM 5%                    | R107                                                                                                                                          |
| 36   | 1   | PS   | 116563  | RES CHIP 1206 CASE | 56K OHM 5%                      | R106                                                                                                                                          |
| 37   | 1   | PS   | 116224  | CHIP RES 1206      | 220 K OHM 1206 CASE 5%          | R105                                                                                                                                          |

PINEAPPLE TECHNOLOGY, INC.  
 4021 ALVIS COURT, #6, ROCKLIN, CA 95677  
 916-315-8338 Fax 916-315-8118

1A0029  
 Page 2 of 3





**VI — SCHEMATICS AND PARTS LIST**

**H. ADP500 MONITOR**

**2. 1A0029 — Parts List (Cont.)**

ADP1000 LOGIC PCB  
 LOGIC BRD PARTS

1A0029  
 Rev A  
 Printed 8/16/2004

| Item | Qty | Type | P/N      | Title                     | Detail                  | Ref(m)                            |
|------|-----|------|----------|---------------------------|-------------------------|-----------------------------------|
| 38   | 3   | PS   | 116000   | RES CHIP 1206             | 0.0 OHMS SM             | R101, 108, 112                    |
| 39   | 7   | PS   | 116XXX   | CHIP RES 1206             | +++NO LOAD+++           | R99, 100, 102, 104, 109, 113, 120 |
| 40   | 3   | PS   | 116101   | RES CHIP 1/8 W            | 100 OHM SM 1206         | R60, 69, 111                      |
| 41   | 2   | PS   | 116223   | RES CHIP 1/8 W            | 22 K OHM SM 1206        | R58, 136                          |
| 42   | 2   | PS   | 116100   | RES CHIP 1/8 W            | 10 OHM SM 1206          | R39, 50                           |
| 43   | 3   | PS   | 1163011  | RES CHIP 1206             | 3.01K OHM 1206 CASE     | R17, 74, 127                      |
| 44   | 4   | PS   | 116472   | RES CHIP 1206             | 4.7K OHM 1/8 W SMT      | R42, 56, 103, 123                 |
| 45   | 1   | PS   | 116392   | RES CHIP 1/8 W            | 3.9 K OHM SM 1206       | R33                               |
| 46   | 4   | PS   | 116162   | RES CHIP 1206             | 1.6K OHM 5% 1206 CASE   | R16, 73, 124, 134                 |
| 47   | 6   | PS   | 116104   | RES CHIP 1/8 W            | 100 K OHM SM 1206       | R15, 110, 126, 129, 132, 133      |
| 48   | 1   | PS   | 17L102XT | RES VAR 12 TURN           | 1K SMT POT 12 TURN      | R32                               |
| 49   | 2   | PS   | 480600   | CON HEADER 0.1 CTRS       | PROTECTED HEADER 34 PIN | J1, J2                            |
| 50   | 1   | PS   | 485001   | HEADER 10 PIN TH          | AMP 0.1 CTR 103308-1    | J79                               |
| 51   | 2   | PS   | 480310   | CON 2 PIN PC POST         | AMP 640456-2            | JP1, 7, 8, 9                      |
| 52   | 1   | PS   | 480320   | CON 4 PIN PC LOCKING POST | MOLES MALE              | JP5                               |
| 53   | 1   | PS   | 520212   | SEMI DIODE SHOTKEY        | 40V 1A                  | D91                               |
| 54   | 3   | PS   | 481250   | CON DB9 SUB RT ANGLE FM   | METAL CASE AMP7457814   | J3, 4, 6                          |



**VI — SCHEMATICS AND PARTS LIST**

**H. ADP500 MONITOR**

**3. 1A0030 — Parts List**

Printed 8/16/2004

ADP1000 FP PCB  
 FP PCB AND PARTS

|          |          |       |
|----------|----------|-------|
| Type     | PL       | User1 |
| Revision | A        | User2 |
| Status   | U        | User3 |
| Date     | 1/5/2002 | User4 |
| By       | RA       | User5 |

| Item | Qty | Type | P/N     | Title               | Detail                  | Ref(m)                                                                                  |
|------|-----|------|---------|---------------------|-------------------------|-----------------------------------------------------------------------------------------|
| Top  |     | PL   | 1A0030  | ADP1000 FP PCB      | FP PCB AND PARTS        |                                                                                         |
| 1    | 1   | PS   | PC9054A | ADP1000 DISPLAY BRD | FR4 060 1/1 CRB         |                                                                                         |
| 2    | 1   | PS   | 483001  | SW, 12 POS ROTOR    | SIG SEL SW ADP1000 SW1  |                                                                                         |
| 3    | 3   | PS   | 484050  | SW, MOMENTARY PB    | OMRON B3WN-6002         | S1, 2, 3                                                                                |
| 4    | 22  | PS   | 150330  | RES 1/4W AXIAL TH   | 1.4 W 330 OHM TH AXIAL  | R10, 11, 22, 24, 37, 38, 44, 45, 49, 67, 68, 77, 78, 82, 86, 90, 91, 94, 95, 96, 97, 98 |
| 5    | 22  | PS   | 630200  | IND LED DUAL COLOR  | RED/GREEN T1-3/4 CLR    | D3, 6, 9, 12, 15, 18, 21, 24, 26, 31, 32, 37, 38, 46, 47, 56, 57, 58, 59, 60, 48, 41    |
| 6    | 2   | PS   | 480600  | CON HEADER 0.1 CTRS | PROTECTED HEADER 34 PIN | J1, 2                                                                                   |



**VI — SCHEMATICS AND PARTS LIST**

**I. AUX5 MONITOR PANEL — Parts List**

Printed 9/7/2004

AUX PANEL 5KW  
 USED ON 3, 4, 5 KW XMTRS

|          |          |       |
|----------|----------|-------|
| Type     | CAT      | User1 |
| Revision | A        | User2 |
| Status   | U        | User3 |
| Date     | 6/7/2004 | User4 |
| By       | RA       | User5 |

| Item | Qty | Type | P/N     | Title                       | Detail                             | Ref(m) |
|------|-----|------|---------|-----------------------------|------------------------------------|--------|
| Top  |     | CAT  | AUX5K   | AUX PANEL 5KW               | USED ON 3, 4, 5 KW XMTRS           |        |
| 2    | 1   | PS   | 484010  | SW, EMERGENCY SHUTDOWN      | NO/NC RESETABLE                    |        |
| 3    | 1   | PS   | AC4200  | AC DUPLEX OUTLET            | 110 VAC 15 A BLACK                 |        |
| 4    | 1   | PS   | 660110  | DC PANEL METER 50 V FS      | HOYT MODEL 3115 1-1/2 ANA PANEL    |        |
| 5    | 1   | PS   | 660114  | DC AMP METER 500 A FS       | HOYT 3115 100mv FS                 |        |
| 6    | 1   | PS   | AC5101  | AC PANEL MT 15 AMP          | 3 PIN SCW MTG                      |        |
| 7    | 3   | PS   | 453000  | HW, TIP JACK                | RED, Insulated standard TIP JACK   |        |
| 8    | 3   | PS   | 453001  | HW TIP JACK                 | WHITE, Insulated standard TIP JACK |        |
| 9    | 1   | PS   | 453002  | HW, TIP JACK                | BLACK, Insulated standard TIP JACK |        |
| 10   | 3   | PS   | 453003  | HW, TIP JACK                | BLUE, Insulated Standard TIP JACK  |        |
| 11   | 3   | PS   | 481100  | CON 9 P D-SUB MALE          | MALE 9P SOLDER CUP                 |        |
| 12   | 3   | PS   | 481200  | CON 9P D-SUB FEMAL          | DB9P SOLDER CUP                    |        |
| 13   | 1   | PS   | 630002  | INDICATOR LITE              | GREEN 120 VAC                      |        |
| 14   | 1   | PS   | MF9330A | CURRENT MONITOR, REAR PANEL | SHUNT AND FUSE MTG PLATE           |        |
| 15   | 1   | PS   | MF9332B | CHASSIS AUX5                | REAR SILK AND ALODYNE              |        |
| 16   | 1   | PS   | 480465  | MOLEX PLUG HOUSING          | 9 POLE MATE-LOC                    |        |
| 17   | 1   | PS   | 480466  | MOLEX CAP HOUSING           | 9 POLE                             |        |
| 18   | 1   | PS   | 480467  | MOLEX STRAIN RELIEFS        | 9 POLE                             |        |
| 19   | 3   | PS   | 480468  | MOLEX SOCKET CONTACTS       | CONN SOCKET 18-24 AWG TIN CRIMP    |        |
| 20   | 3   | PS   | 480469  | MOLEX PIN CONTACTS          | CONN PIN 18-24 AWG TIN CRIMP       |        |
| 21   | 1   | PS   | 480470  | MOLEX PLUG STR 3 PIN        | MOLEX 39-01-4032-P                 |        |
| 22   | 1   | PS   | 480471  | MOLEX RECEPTACLE HSN 3 PIN  | MOLEX 39-01-4030                   |        |
| 25   | 1   | PS   | 460150  | FUSE HOLDER PANEL MTG       | 3AG TYPE QC CON                    |        |
| 26   | 1   | PS   | 480472  | MOLEX CRIMP TERM MFA1KW     | MOLEX MFG 39-00-0041               |        |

PINEAPPLE TECHNOLOGY, INC.  
 4021 ALVIS COURT, #6, ROCKLIN, CA 95677  
 916-315-8338 Fax 916-315-8118

AUX5K  
 Page 1 of 2



**VI — SCHEMATICS AND PARTS LIST**  
**I. AUX5 MONITOR PANEL — Parts List (cont.)**

Printed 9/7/2004

AUX PANEL 5KW  
 USED ON 3, 4, 5 KW XMTRS

|          |          |       |
|----------|----------|-------|
| Type     | CAT      | User1 |
| Revision | A        | User2 |
| Status   | U        | User3 |
| Date     | 6/7/2004 | User4 |
| By       | RA       | User5 |

| Item | Qty | Type | P/N     | Title                       | Detail                             | Ref(m) |
|------|-----|------|---------|-----------------------------|------------------------------------|--------|
| Top  |     | CAT  | AUX5K   | AUX PANEL 5KW               | USED ON 3, 4, 5 KW XMTRS           |        |
| 2    | 1   | PS   | 484010  | SW, EMERGENCY SHUTDOWN      | NO/NC RESETABLE                    |        |
| 3    | 1   | PS   | AC4200  | AC DUPLEX OUTLET            | 110 VAC 15 A BLACK                 |        |
| 4    | 1   | PS   | 660110  | DC PANEL METER 50 V FS      | HOYT MODEL 3115 1-1/2 ANA PANEL    |        |
| 5    | 1   | PS   | 660114  | DC AMP METER 500 A FS       | HOYT 3115 100mv FS                 |        |
| 6    | 1   | PS   | AC5101  | AC PANEL MT 15 AMP          | 3 PIN SCW MTG                      |        |
| 7    | 3   | PS   | 453000  | HW, TIP JACK                | RED, Insulated standard TIP JACK   |        |
| 8    | 3   | PS   | 453001  | HW TIP JACK                 | WHITE, Insulated standard TIP JACK |        |
| 9    | 1   | PS   | 453002  | HW, TIP JACK                | BLACK, Insulated standard TIP JACK |        |
| 10   | 3   | PS   | 453003  | HW, TIP JACK                | BLUE, Insulated Standard TIP JACK  |        |
| 11   | 3   | PS   | 481100  | CON 9 P D-SUB MALE          | MALE 9P SOLDER CUP                 |        |
| 12   | 3   | PS   | 481200  | CON 9P D-SUB FEMAL          | DB9P SOLDER CUP                    |        |
| 13   | 1   | PS   | 630002  | INDICATOR LITE              | GREEN 120 VAC                      |        |
| 14   | 1   | PS   | MF9330A | CURRENT MONITOR, REAR PANEL | SHUNT AND FUSE MTG PLATE           |        |
| 15   | 1   | PS   | MF9332B | CHASSIS AUX5                | REAR SILK AND ALODYNE              |        |
| 16   | 1   | PS   | 480465  | MOLEX PLUG HOUSING          | 9 POLE MATE-LOC                    |        |
| 17   | 1   | PS   | 480466  | MOLEX CAP HOUSING           | 9 POLE                             |        |
| 18   | 1   | PS   | 480467  | MOLEX STRAIN RELIEFS        | 9 POLE                             |        |
| 19   | 3   | PS   | 480468  | MOLEX SOCKET CONTACTS       | CONN SOCKET 18-24 AWG TIN CRIMP    |        |
| 20   | 3   | PS   | 480469  | MOLEX PIN CONTACTS          | CONN PIN 18-24 AWG TIN CRIMP       |        |
| 21   | 1   | PS   | 480470  | MOLEX PLUG STR 3 PIN        | MOLEX 39-01-4032-P                 |        |
| 22   | 1   | PS   | 480471  | MOLEX RECEPTACLE HSN 3 PIN  | MOLEX 39-01-4030                   |        |
| 25   | 1   | PS   | 460150  | FUSE HOLDER PANEL MTG       | 3AG TYPE QC CON                    |        |
| 26   | 1   | PS   | 480472  | MOLEX CRIMP TERM MFA1KW     | MOLEX MFG 39-00-0041               |        |



**VI — SCHEMATICS AND PARTS LIST**  
**J. FP6 FUSE & SHUNT PANEL — Parts List**

Printed 9/7/2004

FUSE PANEL UTX3KWA  
 INC FUSE, SHUNT, SHIELD

|          |           |       |
|----------|-----------|-------|
| Type     | CAT       | User1 |
| Revision | A         | User2 |
| Status   | U         | User3 |
| Date     | 8/24/2004 | User4 |
| By       | RA        | User5 |

| Item | Qty | Type | P/N    | Title                      | Detail                                        | Ref(m) |
|------|-----|------|--------|----------------------------|-----------------------------------------------|--------|
| Top  |     | CAT  | FP-6   | FUSE PANEL<br>UTX3KWA      | INC FUSE, SHUNT,<br>SHIELD                    |        |
| 2    | 6   | PS   | 471380 | FUSE FAST ACTING 80<br>AMP | USE WITH LFFB0001<br>HOLDER                   |        |
| 3    | 6   | PS   | 460190 | FUSE HOLDER 400A           | LITTELFUSE<br>LFFB0001                        |        |
| 4    | 1   | PS   | 670500 | SHUNT, METER               | Lightweight shunt, 100<br>Millivolt, 500 amp. |        |



## **VII — ROUTINE MAINTENANCE**

The following KEY MAINTENANCE AND PERFORMANCE CHECKS should be made monthly or more frequently in some environments where dust is a problem:

### **TRANSMITTER**

- Remove and clean the air filters with a light detergent and **DRY COMPLETELY** before re-installing. **Dirty filters will cause PA amps to shutdown resulting in a loss of RF Power.** Spare filter P/N 990199 is available from Pineapple Technology, Inc.
- Check and record the voltage and current meter readings on the ACDIS3 (AC AND DC DISTRIBUTION UNIT LOCATED NEAR THE POWER SUPPLIES). NOTE: current readings will vary with picture content, Therefore a standard video waveform such as SMPTE BARS should be used.
- Using the ADP500 & PAS10 — record the bias level settings on each PA Pallet by selecting the appropriate PA with the selector switch. To make this measurement of BIAS ONLY it is necessary to activate the PA INHIBIT switch momentarily for each reading.
- Using the ADP500 — check and record the RF Output power level to ensure that it is still reading 100% +/- 10% from the previous settings.
- Using the ADP500 — check and record the VSWR (Reflected power) to ensure that it is still reading only a few percent indicating normal load operations.
- Using the ADP500 — check and record Aural power readings. This is normally set at 10% of P-sync. Expect this to vary only a few percent from reading to reading.
- Carefully inspect RF Output coax and coaxial fittings for excessive heating or discoloration.
- Check DC power connections on shunt panel and power supplies for over heating and tighten as needed.
- Check DC connections on PA rear panel.

### **FACILITIES**

- Clean all air inlet filters and exhaust outlets to ensure that the transmitter is getting clean unobstructed air flow.
- Perform recommended service on air condition systems.
- Rodent traps or baits should be renewed to keep the facilities clear of these pests which can cause damage to the transmitter.



## **VIII — ADJUSTMENTS AND TUNING**

The UTX3KW-A is basically an FCC Type Certified broadband transmitter with a few frequency selective sub-assemblies. A list of these sub-assemblies are listed below and followed by general instructions where applicable:

- A. MODULATOR** — Instructions for making adjustments to the modulator are included in the Manufacturer's Instruction Manual.
- B. BPU3KW Band Pass Filter** comes adjusted to the channel as purchased. To change frequency would require a tuning adjustment to the filter. To perform this adjustment it is necessary to use a NETWORK ANALYZER and a signal generator with necessary I/O Adaptors to connect to the filter. The Technician performing this adjustment should be skilled in tuning Band Pass Filters. If the target frequency is outside of the tuning range of the filter, it becomes necessary to purchase a new filter. Replacement filters and service is available from Pineapple Technology, Inc.
- C. U600LDV-2 POWER AMPLIFIER MODULE** — The U600LDV-2 has three areas where adjustments may be necessary over time or in the event of a frequency change. These areas are:
  - 1. Bias adjustments: The LDMOS FET devices used in these pallet amplifiers are set to 500ma/device side or a total of 1 amp/device. This adjustment can be made on the bench by first terminating the input and output with 50 ohm terminations. Apply 31 volts DC to the PA using a power supply that can provide a minimum of 15 amps. Note: a cooling fan will be necessary to cool the amplifier during this adjustment.

To adjust the bias' it is best to turn all the bias adjust resistors CCW or to minimum on the pallet being adjusted. Using a clamp on the AMP Meter connected to the DC Feed terminal — located on the DC ISOLATION AND CURRENT MONITOR BOARD — measure the current levels. The first resistor is increased to 500ma indicated on the Amp meter. Repeat this adjustment for each additional resistor for reading of 1.0 A, 1.5 A, and 2.0 A. This will indicate that each device half is set to 500 ma.

This concludes the bias adjustment procedure. This adjustment should be made at any time when a device has to be replaced. Normal bias ranges from 1.5 amps to 2.3 amps per pallet as indicated on the ADP500/1000. **DO NOT USE THE ADP500/1000 CURRENT READINGS FOR MAKING BIAS ADJUSTMENTS.**

- 2. PA PALLET RF circuit tuning: These circuits are broadband and fixed tuned providing no adjustments. Any tuning at this level is performed by the factory.



**3. GAIN & PHASE MATCHING:** Each U600LDV-2 comes with a circuit for making Gain and Phase adjustments. This adjustment is fixed tuned for the channel of this transmitter. Adjustment to these circuits require the following equipment:

- HP 8508A VECTOR VOLTMETER
- BIRD THRU LINE WATT METER
- SPLITTER
- 2ea DIRECTIONAL COUPLERS
- 2 ea. 500 watt terminations
- Component selection charts for resistors
- Component selection chart for capacitors

Component selection charts and setup block diagram provided as needed. Recommended tuning should be within +/- 0.15 dB and +/- 3 degrees as measured on the HP 8508A.

**D. PHASE MATCHED CABLES:** The cables used to connect the splitter to the PA Amplifier inputs and those provided to connect the PA Amplifiers to the combiner are phase matched. If a cable is damaged and needs to be replaced, additional cables are available from Pineapple Technology, Inc. The customer may manufacture additional cables, however the same coax type with the same connector types should be used. The phase matching procedure listed above may be used for adjusting the lengths. Matching should be within +/- 2 degrees.

**E. ADP500/1000 WATT METER:** This unit comes calibrated from the factory for the rated power level of the transmitter. Adjustments are not recommended in the field.





## IX — PROBLEM SOLVING/TROUBLE SHOOTING

The UTX3KW-A is a complex assembly of Digital and Analog circuits and in many cases it is advisable to contact Pineapple Technology, Inc. for assistance. If it is necessary to perform field service on the transmitter, most parts are available from Pineapple Technology, Inc. for next day shipment.

The failure analysis of the transmitter starts off with the following assumptions:

- A. The transmitter is connected to an AC source which is within the specified voltage range and has ample power to run the transmitter. This would normally be 208-230 V AC 3-phase with a minimum of 75 Amps available.
- B. The antenna has been checked out and verified to have a VSWR of 1.2:1 or better.
- C. The room temperature is < 35 degrees Celsius.
- D. There are no restrictions on the air flow in or out of the building.
- E. The video and aural signals, to the Modulator, comply with stated specifications.

### CHECKING THE WARNING LIGHTS

MFA1KW: This unit has dual performance indicator lights located above the air inlets. One set of lights for each PA assembly located inside the unit.

|              |       |        |
|--------------|-------|--------|
| HS OVER TEMP | GREEN | NORMAL |
|              | RED   | FAULT  |
| +28 VDC      | GREEN | NORMAL |
|              | RED   | FAULT  |
| FAN SUPPLY   | GREEN | NORMAL |
|              | RED   | FAULT  |

**HS OVER TEMP FAULT** could indicate one of the following problems:

- a. Room temperature is too high and the heat sinks are over heating
- b. High VSWR on PA output port will cause the Dump-load sensor to fault.
- c. Air filters are dirty and need to be cleaned.
- d. Exhaust fan failure (located in the top of the rack).

**+28 VDC FAULT** could indicate a power supply failure. Check the ADP500 & PAS10 for PA voltage and current readings. The power supply modules will also indicate a loss of power.

**FAN FAULT** indications could mean that the PA blower has failed or there has been a loss of AC power to the fan. There is also a fuse located just inside of the front panel in case there is a locked rotor failure



condition. To access the fuse, the MFA1KW must be removed from the rack and the top cover removed. This is a 5 AMP 3 AG type fuse.

**ADP500:** There are a number of fault indicator lights on this unit that can be used for trouble shooting possible problems with the transmitter.

With normal operating conditions, all the LEDs located on the front panel should be green. Red lights could indicate a fault in normal operations of the transmitter. Fault indicators are listed below:

- a. **ANT VSWR HIGH light is RED.** This indicated that the antenna reflected power exceeds the set point in the equipment which is normally set to 10 %. When this LED is on, the transmitter shutdown line is pulled down to ZERO and the transmitter RF PWR OFF LED will also light RED indicating that the transmitter has been shutdown at the driver level. This condition will automatically reset when the problem is corrected. CHECK THE ANTENNA FOR POSSIBLE FAULTS.
- b. **RF PWR OFF light is RED.** This will occur anytime the “SHUTDOWN LINE” is pulled to ZERO. This control line is pulled to ZERO with any of the following faults:

1. **ANT VSWR HIGH**

2. **PA INHIBIT SWITCH IN THE INHIBIT MODE**

NOTICE: ONLY THE PA INHIBIT SWITCH OR THE ANT VSWR HIGH WILL SHUTDOWN THE TRANSMITTER DRIVE CAUSING THE RF OUTPUT TO FALL TO NEAR ZERO.

- c. **PA1 THRU PA5 LEDs RED** would indicate that the PA Pallet current level has fallen below the set point and could indicate a transistor failure. The normal current with the “inhibit” switch activated is 500 ma.

## RR6000 POWER SUPPLY MODULES

The Power Supply module has two warning lights located on the front panel. Normally these lights are GREEN indicating that the AC Line voltage and the Over voltage circuits are within their normal range. Should either go out of range, the lights will turn RED and the power supply module will shutdown. This will reduce the available power to the RF Stages and could result in lower RF Output Power from the transmitter. If this happens, turn off the transmitter for about one (1) minute and then turn it back on. If this warning continues, the modules should be removed from the rack and returned for service — a spare module should be installed to maintain normal operations.

NOTICE: The UTX3KW-A transmitter has six (6) each 2 KW power modules. Under normal conditions, this is enough head room to allow the removal of one power supply module with little or no reduction in output power. In the event it becomes necessary to remove a module and the RF Output power drops, the RF Drive level from the Modulator can be reduced to a point where the DC Volt meter on the ACDIS3 reads 31 volts. This is the maximum output level obtainable with one power supply module removed. On this transmitter that could be a reduction of less than 500 watts in operational output power. This will keep the station on the air until the new power supply module arrives. **DON'T FORGET TO TURN THE DRIVE LEVEL UP AFTER INSTALLING THE NEW SUPPLY TO RETURN TO 100% OPERATION.**



## **X — WARRANTY**

The WARRANTY provided by Pineapple Technology, Inc. (PTI) on this transmitter is detailed below. It should be noted that some of the equipment sub-systems have warranty coverage by the original manufacture that differs from the standard warranty provided by PTI. Warranty details on equipment falling into this category may be found in the Manufactures instruction manual provided with the transmitter. In all cases, replacement units of this equipment are normally in stock at PTI for quick turn service support to our customers during the PTI Standard Warranty period.

### **STANDARD WARRANTY**

Seller warrants that each Product sold by it is free of defects in materials and workmanship. Seller's obligation under said warranty continues for a period of one (1) year from date of shipment. Repairs or replacement of defective parts shall be the sole and exclusive remedy under warranty, at Seller option, provided that Seller may, as an alternative, elect to refund an equitable portion of the purchase price of the product. THIS WARRANTY IS EXPRESSLY IN LIEU OF AND EXCLUDES ALL OTHER EXPRESS OR IMPLIED WARRANTIES, INCLUDING BUT NOT LIMITED TO WARRANTIES OF FITNESS FOR A PARTICULAR PURPOSE, USE, OR APPLICATION, AND ALL OTHER OBLIGATIONS OR LIABILITIES ON THE PART OF THE SELLER, UNLESS SUCH OTHER WARRANTIES, OBLIGATIONS OR LIABILITIES ARE EXPRESSLY AGREED TO IN WRITING BY SELLER.

### **WARRANTY REPLACEMENT AND REPAIRS**

All claims under warranty must be made promptly after occurrence of circumstances giving rise to thereto and must be received with in the applicable warranty period by seller or its authorized representative. Such claims must be documented on a PTI \*Field Failure Report with a full description of the circumstances giving rise to the claim. Before any products are returned for repair and/or adjustment, written authorization form seller or its authorized representative for the return and instructions as to how and where these products should be shipped must be obtained — This is to include a Return Authorization (RA) number provided by the seller or authorized representative, this must accompany ALL returns. Any product returned to seller for the examination shall be sent prepaid via the means of transportation indicated as acceptable by seller. Seller reserves the right to reject any warranty claim not promptly reported and any claim on any item that has been altered, i.e. circuit modifications, components removed, or has been shipped by non acceptable means of transportation. When a product has been returned for examination and inspection, or for any other reason, customer shall be responsible for all damage resulting from improper packaging or handling, and for loss in transit, notwithstanding any defect or nonconformity in the product. In all cases the seller has sole responsibility for determining the cause and nature of the failure, and the Seller's determination with regard thereto shall be final. If it is found that Seller's Product has been returned without cause and is still serviceable, customer will be notified and the Product returned at its expense, in addition, a charge for testing and examination may, in Sellers sole discretion be made on Products so returned.

*\*A Field Failure Report is included at the end of this manual — Additional Field Failure Reports can be obtained by calling Pineapple Technology, Inc. at (916) 315-8338 or you may download one from our web site at [www.ptibroadcast.com](http://www.ptibroadcast.com) in the Warranty section.*



**XI — EXTENDED WARRANTY (OPTIONAL)**

Pineapple Technology, Inc. transmitters come with the option of extending the standard warranty for up to 5 years. To exercise this option, the purchaser must buy and pay for the option at the time the transmitter is purchased. The cost of the EXTENDED WARRANTY OPTION is in accordance with the following schedule:

|          |                                  |
|----------|----------------------------------|
| 1st year | NO CHARGE                        |
| 2nd year | 5% of transmitter purchase price |
| 3rd year | 5% of transmitter purchase price |
| 4th year | 5% of transmitter purchase price |
| 5th year | 5% of transmitter purchase price |

A five year EXTENDED WARRANTY would cost 20% of the original selling price of the transmitter. The purchaser may exercise all or part of the EXTENDED WARRANTY as needed.