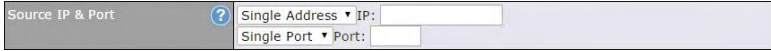
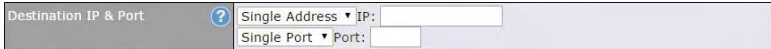

# Pepwave MAX and Surf User Manual

## Inbound / Outbound Firewall Settings

<b>Rule Name</b>	This setting specifies a name for the firewall rule.
<b>Enable</b>	<p>This setting specifies whether the firewall rule should take effect. If the box is checked, the firewall rule takes effect. If the traffic matches the specified protocol/IP/port, actions will be taken by the Pepwave router based on the other parameters of the rule. If the box is not checked, the firewall rule does not take effect. The Pepwave router will disregard the other parameters of the rule.</p> <p>Click the dropdown menu next to the checkbox to place this firewall rule on a time schedule.</p>
<b>WAN Connection (Inbound)</b>	Select the WAN connection that this firewall rule should apply to.
<b>Protocol</b>	<p>This setting specifies the protocol to be matched. Via a drop-down menu, the following protocols can be specified:</p> <ul style="list-style-type: none"><li>• TCP</li><li>• UDP</li><li>• ICMP</li><li>• IP</li></ul> <p>Alternatively, the <b>Protocol Selection Tool</b> drop-down menu can be used to automatically fill in the protocol and port number of common Internet services (e.g., HTTP, HTTPS, etc.) After selecting an item from the <b>Protocol Selection Tool</b> drop-down menu, the protocol and port number remains manually modifiable.</p>
<b>Source IP &amp; Port</b>	<p>This specifies the source IP address(es) and port number(s) to be matched for the firewall rule. A single address, or a network, can be specified as the <b>Source IP &amp; Port</b> setting, as indicated by the following screenshot:</p>  <p>In addition, a single port, or a range of ports, can be specified for the <b>Source IP &amp; Port</b> settings.</p>
<b>Destination IP &amp; Port</b>	<p>This specifies the destination IP address(es) and port number(s) to be matched for the firewall rule. A single address, or a network, can be specified as the <b>Destination IP &amp; Port</b> setting, as indicated by the following screenshot:</p>  <p>In addition, a single port, or a range of ports, can be specified for the <b>Destination IP &amp; Port</b> settings.</p>
<b>Action</b>	<p>This setting specifies the action to be taken by the router upon encountering traffic that matches the both of the following:</p> <ul style="list-style-type: none"><li>• Source IP &amp; port</li><li>• Destination IP &amp; port</li></ul> <p>With the value of <b>Allow</b> for the <b>Action</b> setting, the matching traffic passes through the router (to be routed to the destination). If the value of the <b>Action</b> setting is set to <b>Deny</b>, the matching traffic does not pass through the router (and is discarded).</p>

# Pepwave MAX and Surf User Manual

This setting specifies whether or not to log matched firewall events. The logged messages are shown on the page **Status>Event Log**. A sample message is as follows:

```
Aug 13 23:47:44 Denied CONN=Ethernet WAN SRC=20.3.2.1  
DST=192.168.1.20 LEN=48 PROTO=TCP SPT=2260 DPT=80
```

## Event Logging

- **CONN:** The connection where the log entry refers to
- **SRC:** Source IP address
- **DST:** Destination IP address
- **LEN:** Packet length
- **PROTO:** Protocol
- **SPT:** Source port
- **DPT:** Destination port

Click **Save** to store your changes. To create an additional firewall rule, click **Add Rule** and repeat the above steps.

To change a rule's priority, simply drag and drop the rule:

- Hold the left mouse button on the rule.
- Move it to the desired position.
- Drop it by releasing the mouse button.

## Tip

If the default inbound rule is set to **Allow** for NAT-enabled WANs, no inbound Allow firewall rules will be required for inbound port forwarding and inbound NAT mapping rules. However, if the default inbound rule is set as **Deny**, a corresponding Allow firewall rule will be required.

# Pepwave MAX and Surf User Manual

## 19.1.2 Apply Firewall Rules to PepVpn Traffic

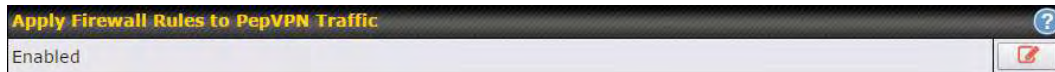

When this option is enabled, Outbound Firewall Rules will be applied to PepVPN traffic. To turn on this feature, click , check the **Enable** check box, and press the **Save** button.

## 19.1.3 Intrusion Detection and DoS Prevention

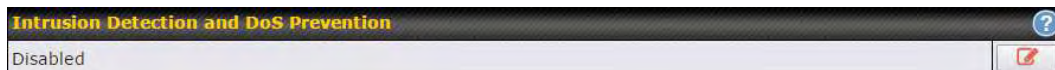

Pepwave routers can detect and prevent intrusions and denial-of-service (DoS) attacks from the Internet. To turn on this feature, click , check the **Enable** check box, and press the **Save** button.

When this feature is enabled, the Pepwave router will detect and prevent the following kinds of intrusions and denial-of-service attacks.

- Port scan
  - NMAP FIN/URG/PSH
  - Xmas tree
  - Another Xmas tree
  - Null scan
  - SYN/RST
  - SYN/FIN
- SYN flood prevention
- Ping flood attack prevention

# Pepwave MAX and Surf User Manual

## 19.2 Content Blocking

**Application Blocking**

Please Select Application...

**Web Blocking**

Preset Category

- High
- Moderate
- Low
- Custom

<input type="checkbox"/> Abortion	<input type="checkbox"/> Adware	<input type="checkbox"/> Aggressive
<input type="checkbox"/> Alcohol	<input type="checkbox"/> Anti-Spyware	<input type="checkbox"/> Chatroom
<input type="checkbox"/> Dating	<input type="checkbox"/> Drugs	<input type="checkbox"/> Ecommerce/Shopping
<input type="checkbox"/> Entertainment	<input type="checkbox"/> File Hosting	<input type="checkbox"/> P2P/File sharing
<input type="checkbox"/> Gambling	<input type="checkbox"/> Games	<input type="checkbox"/> Hacking
<input type="checkbox"/> Instant Messaging	<input type="checkbox"/> Job Search/Employment	<input type="checkbox"/> Kids Time Wasting
<input type="checkbox"/> Lingerie	<input type="checkbox"/> Malware	<input type="checkbox"/> Manga/Anime/Webcomic
<input type="checkbox"/> Nudity	<input type="checkbox"/> News/Media	<input type="checkbox"/> Auctions
<input type="checkbox"/> Phishing	<input type="checkbox"/> Pornography	<input type="checkbox"/> Proxy/Anonymizer
<input type="checkbox"/> Radio	<input type="checkbox"/> Remote Access	<input type="checkbox"/> Ringtones
<input type="checkbox"/> Search Engines	<input type="checkbox"/> Sexuality Education	<input type="checkbox"/> Social Networking
<input type="checkbox"/> Sports	<input type="checkbox"/> Spyware	<input type="checkbox"/> Tobacco
<input type="checkbox"/> Update Sites	<input type="checkbox"/> Vacation	<input type="checkbox"/> Violence
<input type="checkbox"/> Viruses	<input type="checkbox"/> Weapons	<input type="checkbox"/> Weather
<input type="checkbox"/> Webmail	<input type="checkbox"/> WebTV	

Customized Domains

cbs.com	<input type="button" value="X"/>
	<input type="button" value="+"/>

Exempted Domains from Web Blocking

	<input type="button" value="+"/>
--	----------------------------------

**Exempted User Groups**

Manager	<input type="checkbox"/> Exempt
Staff	<input type="checkbox"/> Exempt
Guest	<input type="checkbox"/> Exempt

**Exempted Subnets**

Network	Subnet Mask
	255.255.255.0 (/24)

**URL Logging**

Enable	<input type="checkbox"/>		
Log Server Host		Port:	

### 19.2.1 Application Blocking

Choose applications to be blocked from LAN/PPTP/PepVPN peer clients' access, except for those on the Exempted User Groups or Exempted Subnets defined below.

### 19.2.2 Web Blocking

Defines web site domain names to be blocked from LAN/PPTP/PepVPN peer clients' access except for those on the Exempted User Groups or Exempted Subnets defined below.

# Pepwave MAX and Surf User Manual

If "foobar.com" is entered, any web site with a host name ending in foobar.com will be blocked, e.g. www.foobar.com, foobar.com, etc. However, "myfoobar.com" will not be blocked.

You may enter the wild card "."\*" at the end of a domain name to block any web site with a host name having the domain name in the middle. If you enter "foobar.\*", then "www.foobar.com", "www.foobar.co.jp", or "foobar.co.uk" will be blocked. Placing the wild card in any other position is not supported.

The device will inspect and look for blocked domain names on all HTTP traffic. Secure web (HTTPS) traffic is not supported.

## 19.2.3 Customized Domains

Enter an appropriate website address, and the Peplink Balance will block and disallow LAN/PPTP/SpeedFusion™ peer clients to access these websites. Exceptions can be added using the instructions in Sections 20.1.3.2 and 20.1.3.3.

You may enter the wild card "."\*" at the end of a domain name to block any web site with a host name having the domain name in the middle. For example, If you enter "foobar.\*," then "www.foobar.com," "www.foobar.co.jp," or "foobar.co.uk" will be blocked. Placing the wild card in any other position is not supported.

The Peplink Balance will inspect and look for blocked domain names on all HTTP traffic. Secure web (HTTPS) traffic is not supported.

## 19.2.4 Exempted User Groups

Check and select pre-defined user group(s) who can be exempted from the access blocking rules. User groups can be defined at **QoS>User Groups** section. Please refer to **Section 17.1** for details.

## 19.2.5 Exempted Subnets

With the subnet defined in the field, clients on the particular subnet(s) can be exempted from the access blocking rules.

## 19.2.6 URL Logging

Click **enable**, and then enter the ip address and port (if applicable) where your remote syslog server is located.

## 19.3 OSPF & RIPv2

The Peplink Balance supports OSPF and RIPv2 dynamic routing protocols. Click the **Network** tab from the top bar, and then click the **OSPF & RIPv2** item on the sidebar to reach the following menu:

# Pepwave MAX and Surf User Manual

## OSPF

**Router ID** This field determines the ID of the router. By default, this is specified as the LAN IP address. If you want to specify your own ID, enter it in the **Custom** field.

**Area** This is an overview of the OSPFv2 areas you have defined. Click on the area name to configure it. To set a new area, click **Add**. To delete an existing area, click .

## OSPF Settings

**Area ID** Determine the name of your **Area ID** to apply to this group. Machines linked to this group will send and receive related OSPF packets, while unlinked machines will ignore it.

**Link Type** Choose the network type that this area will use.

**Authentication** Choose an authentication method, if one is used, from this drop-down menu. Available options are **MD5** and **Text**. Enter the authentication key next to the drop-down menu.

**Interfaces** Determine which interfaces this area will use to listen to and deliver OSPF packets

# Pepwave MAX and Surf User Manual

To access RIPv2 settings, click .

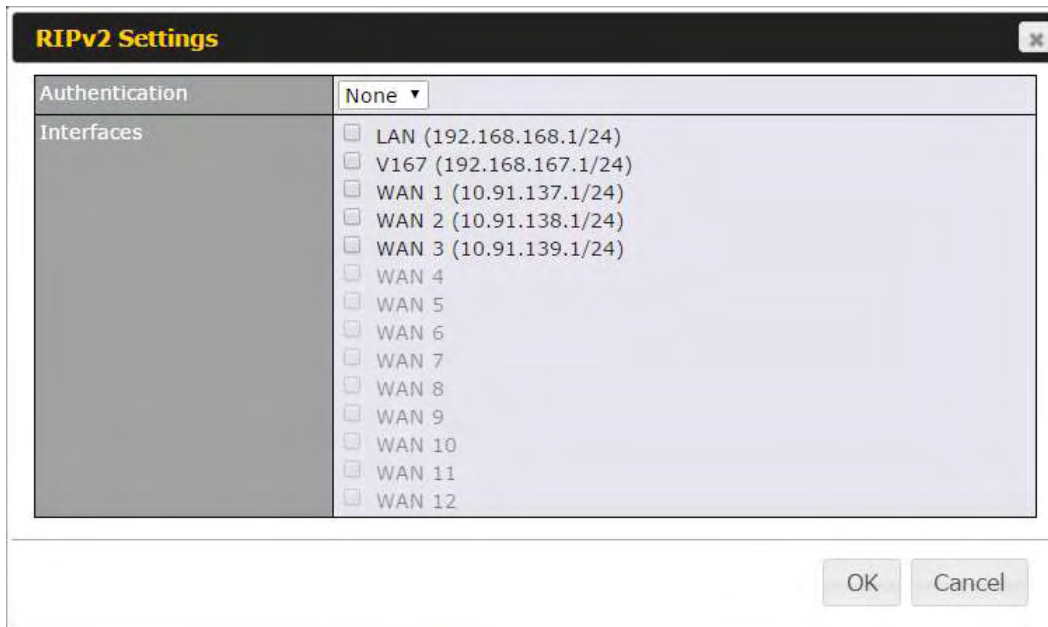

Authentication	None ▾
Interfaces	<input type="checkbox"/> LAN (192.168.168.1/24) <input type="checkbox"/> V167 (192.168.167.1/24) <input type="checkbox"/> WAN 1 (10.91.137.1/24) <input type="checkbox"/> WAN 2 (10.91.138.1/24) <input type="checkbox"/> WAN 3 (10.91.139.1/24) <input type="checkbox"/> WAN 4 <input type="checkbox"/> WAN 5 <input type="checkbox"/> WAN 6 <input type="checkbox"/> WAN 7 <input type="checkbox"/> WAN 8 <input type="checkbox"/> WAN 9 <input type="checkbox"/> WAN 10 <input type="checkbox"/> WAN 11 <input type="checkbox"/> WAN 12

OK Cancel

RIPv2 Settings	
<b>Authentication</b>	Choose an authentication method, if one is used, from this drop-down menu. Available options are <b>MD5</b> and <b>Text</b> . Enter the authentication key next to the drop-down menu.
<b>Interfaces</b>	Determine which interfaces this group will use to listen to and deliver RIPv2 packets.

## 19.4 Remote User Access

a Networks routed by a Peplink Balance can be remotely accessed via L2TP with IPsec or PPTP. To configure this feature, navigate to **Network > Remote User Access**

# Pepwave MAX and Surf User Manual

Remote User Access Settings										
Enable	<input checked="" type="checkbox"/>									
VPN Type	<input checked="" type="radio"/> L2TP with IPsec <input type="radio"/> PPTP IPsec NAT-Traversal will be enabled to ensure compatibility for most of the devices									
Preshared Key	..... <input checked="" type="checkbox"/> Hide Characters									
Listen On	? <b>Connection / IP Address(es)</b>									
	<input checked="" type="checkbox"/> WAN1	<input checked="" type="checkbox"/> 10.10.12.47 (Interface IP)								
	<input checked="" type="checkbox"/> WAN2	<input checked="" type="checkbox"/> Interface IP								
	<input checked="" type="checkbox"/> WAN3	<input checked="" type="checkbox"/> Interface IP								
	<input checked="" type="checkbox"/> Mobile Internet	<input checked="" type="checkbox"/> Interface IP								
User Accounts	?									
	<table border="1"> <thead> <tr> <th>Username</th> <th>Password</th> <th></th> </tr> </thead> <tbody> <tr> <td>admin</td> <td>.....</td> <td>X</td> </tr> <tr> <td></td> <td></td> <td>+</td> </tr> </tbody> </table>	Username	Password		admin	.....	X			+
Username	Password									
admin	.....	X								
		+								

Remote User Access Settings	
<b>Enable</b>	Click the checkbox to enable Remote User Access.
<b>VPN Type</b>	Determine whether remote devices can connect to the Balance using L2TP with IPsec or PPTP. For greater security, we recommend you connect using L2TP with IPsec.
<b>Preshared Key</b>	Enter your preshared key in the text field. Please note that remote devices will need this preshared key to access the Balance.
<b>Listen On</b>	This setting is for specifying the WAN IP addresses where the PPTP server of the router should listen on.
<b>User Accounts</b>	<p>This setting allows you to define the PPTP User Accounts. Click Add to input username and password to create an account. After adding the user accounts, you can click on a username to edit the account password. Click the button X to delete the account in its corresponding row.</p> <p>Click the ? button to switch to enters user accounts by pasting the information in.CSV format.</p>



## Miscellaneous Settings

The miscellaneous settings include configuration for high availability, PPTP server, service forwarding, and service passthrough.

### 19.5 High Availability

Many Pepwave routers support high availability (HA) configurations via an open standard virtual router redundancy protocol (VRRP, RFC 3768). In an HA configuration, two Pepwave routers provide redundancy and failover in a master-slave arrangement. In the event that the master unit is down, the slave unit becomes active. High availability will be disabled automatically where there is a drop-in connection configured on a LAN bypass port.

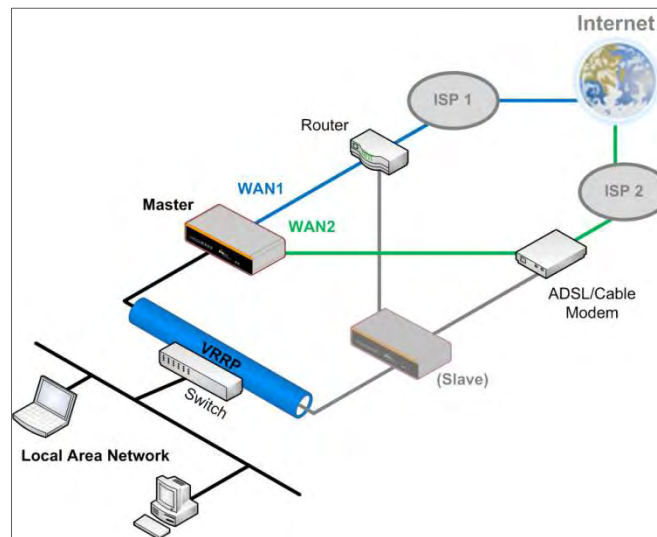

In the diagram, the WAN ports of each Pepwave router connect to the router and to the modem. Both Pepwave routers connect to the same LAN switch via a LAN port.

An elaboration on the technical details of the implementation of the virtual router redundancy protocol (VRRP, RFC 3768) by Pepwave routers follows:

- In an HA configuration, the two Pepwave routers communicate with each other using VRRP over the LAN.
- The two Pepwave routers broadcast heartbeat signals to the LAN at a frequency of one heartbeat signal per second.
- In the event that no heartbeat signal from the master Pepwave router is received in 3 seconds (or longer) since the last heartbeat signal, the slave Pepwave router becomes active.
- The slave Pepwave router initiates the WAN connections and binds to a previously configured LAN IP address.
- At a subsequent point when the master Pepwave router recovers, it will once again become active.

# Pepwave MAX and Surf User Manual

You can configure high availability at **Advanced>Misc. Settings>High Availability**.

Interface for Master Router

Interface for Slave Router

High Availability		High Availability	
Enable	<input checked="" type="checkbox"/>	Enable	<input checked="" type="checkbox"/>
Group Number	5	Group Number	5
Preferred Role	<input checked="" type="radio"/> Master <input type="radio"/> Slave	Preferred Role	<input type="radio"/> Master <input checked="" type="radio"/> Slave
Resume Master Role Upon Recovery	<input checked="" type="checkbox"/>	Configuration Sync.	<input type="checkbox"/> Master Serial Number: 54BF-5WEY-E37Q
Virtual IP		Virtual IP	
LAN Administration IP	192.168.1.1	LAN Administration IP	192.168.1.1
Subnet Mask	255.255.255.0	Subnet Mask	255.255.255.0

High Availability	
<b>Enable</b>	Checking this box specifies that the Pepwave router is part of a high availability configuration.
<b>Group Number</b>	This number identifies a pair of Pepwave routers operating in a high availability configuration. The two Pepwave routers in the pair must have the same <b>Group Number</b> value.
<b>Preferred Role</b>	This setting specifies whether the Pepwave router operates in master or slave mode. Click the corresponding radio button to set the role of the unit. One of the units in the pair must be configured as the master, and the other unit must be configured as the slave.
<b>Resume Master Role Upon Recovery</b>	This option is displayed when <b>Master</b> mode is selected in <b>Preferred Role</b> . If this option is enabled, once the device has recovered from an outage, it will take over and resume its <b>Master</b> role from the slave unit.
<b>Configuration Sync.</b>	This option is displayed when <b>Slave</b> mode is selected in <b>Preferred Role</b> . If this option is enabled and the <b>Master Serial Number</b> entered matches with the actual master unit's, the master unit will automatically transfer the configuration to this unit. Please make sure the <b>LAN IP Address</b> and the <b>Subnet Mask</b> fields are set correctly in the LAN settings page. You can refer to the <b>Event Log</b> for the configuration synchronization status.
<b>Master Serial Number</b>	If <b>Configuration Sync.</b> is checked, the serial number of the master unit is required here for the feature to work properly.
<b>Virtual IP</b>	The HA pair must share the same <b>Virtual IP</b> . The <b>Virtual IP</b> and the <b>LAN Administration IP</b> must be under the same network.
<b>LAN Administration IP</b>	This setting specifies a LAN IP address to be used for accessing administration functionality. This address should be unique within the LAN.
<b>Subnet Mask</b>	This setting specifies the subnet mask of the LAN.

# Pepwave MAX and Surf User Manual

## Important Note

For Pepwave routers in NAT mode, the virtual IP (VIP) should be set as the default gateway for all hosts on the LAN segment. For example, a firewall sitting behind the Pepwave router should set its default gateway as the virtual IP instead of the IP of the master router.

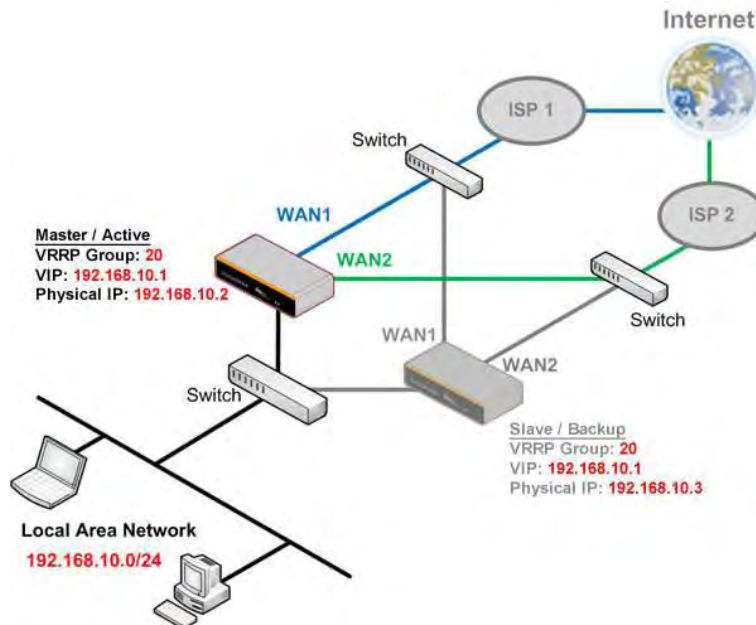

In drop-in mode, no other configuration needs to be set.

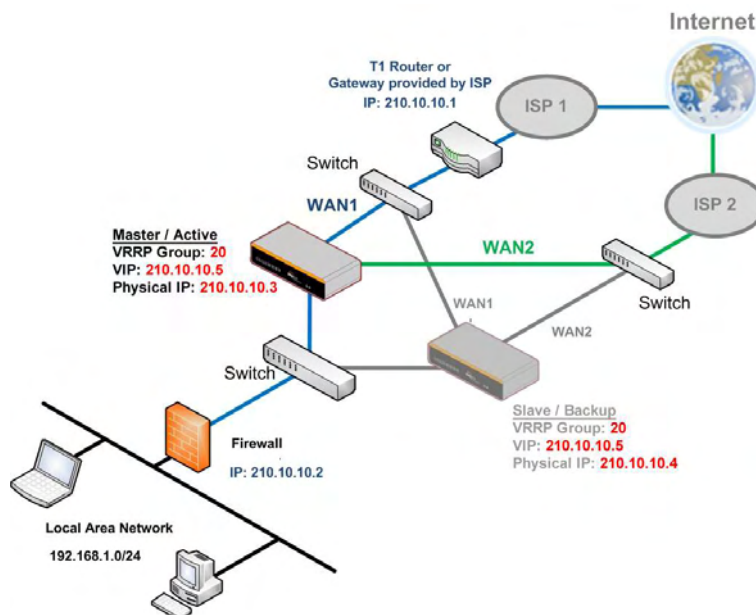

Please note that the drop-in WAN cannot be configured as a LAN bypass port while it is configured for high availability.

# Pepwave MAX and Surf User Manual

## 19.6 PPTP Server



Pepwave routers feature a built-in PPTP server, which enables remote computers to conveniently and securely access the local network. PPTP server settings are located at **Advanced>Misc. Settings>PPTP Server**.

Check the box to enable PPTP server functionality. All connected PPTP sessions are displayed at **Status>Client List**. Please refer to **Section 22.3** for details. Note that available options vary by model.

PPTP Server	
Enable	<input checked="" type="checkbox"/>
Listen On	<b>Connection / IP Address(es)</b>
	<input checked="" type="checkbox"/> WAN 1 <input checked="" type="checkbox"/> 10.88.3.158 (Interface IP)
	<input checked="" type="checkbox"/> WAN 2 <input checked="" type="checkbox"/> Interface IP
	<input checked="" type="checkbox"/> Wi-Fi WAN <input checked="" type="checkbox"/> Interface IP
	<input checked="" type="checkbox"/> Cellular 1 <input checked="" type="checkbox"/> Interface IP
	<input checked="" type="checkbox"/> Cellular 2 <input checked="" type="checkbox"/> Interface IP
	<input checked="" type="checkbox"/> USB <input checked="" type="checkbox"/> Interface IP
Authentication	<input checked="" type="checkbox"/> Local User Accounts ▼
User Accounts	<input checked="" type="checkbox"/> Username
	Password
	<input type="text"/> <input type="text"/> <input type="button" value="+"/>

# Pepwave MAX and Surf User Manual

PPTP Server Settings	
<b>Listen On</b>	This setting is for specifying the WAN connection(s) and IP address(es) that the PPTP server should listen on.
<b>Authentication</b>	This setting is for specifying the user database source for PPTP authentication. Three sources can be selected: <b>Local User Accounts</b> , <b>LDAP Server</b> , or <b>RADIUS Server</b> . <b>Local User Accounts</b> - User accounts are stored in the Pepwave router locally. You can add/modify/delete accounts in the <b>User Accounts</b> table. <b>LDAP Server</b> - Authenticate with an external LDAP server. This has been tested with Open LDAP servers where passwords are NTLM hashed. Active Directory is not supported. (You can choose to use RADIUS to authenticate with a Windows server.) <b>RADIUS Server</b> - Authenticate with an external RADIUS server. This has been tested with Microsoft Windows Internet Authentication Service and FreeRADIUS servers where passwords are NTLM hashed or in plain text.
<b>User Accounts</b>	This setting allows you to define PPTP user accounts <a href="#">for authentication via local user accounts</a> . Click <b>Add</b> to input username and password to create an account. After adding the user accounts, you can click on a username to edit the account password. Click  to delete the account in its corresponding row.

## 19.7 Certificate Manager

Certificate Manager		
VPN Certificate	 No Certificate	<a href="#">Assign</a>
Web Admin SSL Certificate	 No Certificate	<a href="#">Assign</a>
Captive Portal SSL Certificate	No Certificate	<a href="#">Assign</a>

This section allows you to assign certificates for local VPN and web admin SSL. The local keys will not be transferred to another device by any means.

## 19.8 Service Forwarding

Service forwarding settings are located at **Advanced>Misc. Settings>Service Forwarding**.

<b>SMTP Forwarding Setup</b> 	
SMTP Forwarding	<input type="checkbox"/> Enable
<b>Web Proxy Forwarding Setup</b> 	
Web Proxy Forwarding	<input type="checkbox"/> Enable
<b>DNS Forwarding Setup</b> 	
Forward Outgoing DNS Requests to Local DNS Proxy	<input type="checkbox"/> Enable
<b>Custom Service Forwarding Setup</b>	
Custom Service Forwarding	<input type="checkbox"/> Enable

Service Forwarding	
<b>SMTP Forwarding</b>	When this option is enabled, all outgoing SMTP connections destined for any host at TCP port 25 will be intercepted. These connections will be redirected to a specified SMTP server and port number. SMTP server settings for each WAN can be specified

# Pepwave MAX and Surf User Manual

	after selecting <b>Enable</b> .
<b>Web Proxy Forwarding</b>	When this option is enabled, all outgoing connections destined for the proxy server specified in <b>Web Proxy Interception Settings</b> will be intercepted. These connections will be redirected to a specified web proxy server and port number. Web proxy interception settings and proxy server settings for each WAN can be specified after selecting <b>Enable</b> .
<b>DNS Forwarding</b>	When this option is enabled, all outgoing DNS lookups will be intercepted and redirected to the built-in DNS name server. If any LAN device is using the DNS name servers of a WAN connection, you may want to enable this option to enhance the DNS availability without modifying the DNS server setting of the clients. The built-in DNS name server will distribute DNS lookups to corresponding DNS servers of all available WAN connections. In this case, DNS service will not be interrupted, even if any WAN connection is down.
<b>Custom Service Forwarding</b>	When custom service forwarding is enabled, outgoing traffic with the specified TCP port will be forwarded to a local or remote server by defining its IP address and port number.

## 19.8.1 SMTP Forwarding

Some ISPs require their users to send e-mails via the ISP's SMTP server. All outgoing SMTP connections are blocked except those connecting to the ISP's. Pepwave routers support intercepting and redirecting all outgoing SMTP connections (destined for TCP port 25) via a WAN connection to the WAN's corresponding SMTP server.

Connection	Enable Forwarding?	SMTP Server	SMTP Port
WAN 1	<input type="checkbox"/>		
WAN 2	<input type="checkbox"/>		
Wi-Fi WAN	<input type="checkbox"/>		
Cellular 1	<input type="checkbox"/>		
Cellular 2	<input type="checkbox"/>		
USB	<input type="checkbox"/>		

To enable the feature, select **Enable** under **SMTP Forwarding Setup**. Check **Enable Forwarding** for the WAN connection(s) that needs forwarding. Under **SMTP Server**, enter the ISP's e-mail server host name or IP address. Under **SMTP Port**, enter the TCP port number for each WAN.

The Pepwave router will intercept SMTP connections. Choose a WAN port according to the outbound policy, and then forward the connection to the SMTP server if the chosen WAN has enabled forwarding. If the forwarding is disabled for a WAN connection, SMTP connections for the WAN will be simply be forwarded to the connection's original destination.

### Note

If you want to route all SMTP connections only to particular WAN connection(s), you should create a custom rule

# Pepwave MAX and Surf User Manual

in outbound policy (see **Section 14.2**).

## 19.8.2 Web Proxy Forwarding

The screenshot shows the 'Web Proxy Forwarding Setup' configuration page. At the top, there is a section for 'Web Proxy Forwarding' with an 'Enable' checkbox checked. Below this is the 'Web Proxy Interception Settings' section, which includes fields for 'Proxy Server' with sub-fields for 'IP Address' and 'Port', and a note '(Current settings in users' browser)'. The main part of the page is a table with three columns: 'Connection', 'Enable Forwarding?', and 'Proxy Server IP Address : Port'. The table lists six connection types: WAN 1, WAN 2, Wi-Fi WAN, Cellular 1, Cellular 2, and USB. Each row has a checkbox in the 'Enable Forwarding?' column and a text input field in the 'Proxy Server IP Address : Port' column.

Connection	Enable Forwarding?	Proxy Server IP Address : Port
WAN 1	<input type="checkbox"/>	<input type="text"/> : <input type="text"/>
WAN 2	<input type="checkbox"/>	<input type="text"/> : <input type="text"/>
Wi-Fi WAN	<input type="checkbox"/>	<input type="text"/> : <input type="text"/>
Cellular 1	<input type="checkbox"/>	<input type="text"/> : <input type="text"/>
Cellular 2	<input type="checkbox"/>	<input type="text"/> : <input type="text"/>
USB	<input type="checkbox"/>	<input type="text"/> : <input type="text"/>

When this feature is enabled, the Pepwave router will intercept all outgoing connections destined for the proxy server specified in **Web Proxy Interception Settings**, choose a WAN connection with reference to the outbound policy, and then forward them to the specified web proxy server and port number. Redirected server settings for each WAN can be set here. If forwarding is disabled for a WAN, web proxy connections for the WAN will be simply forwarded to the connection's original destination.

## 19.8.3 DNS Forwarding

The screenshot shows the 'DNS Forwarding Setup' configuration page. It features a section for 'Forward Outgoing DNS Requests to Local DNS Proxy' with an 'Enable' checkbox checked.

When DNS forwarding is enabled, all clients' outgoing DNS requests will also be intercepted and forwarded to the built-in DNS proxy server.

## 19.8.4 Custom Service Forwarding

The screenshot shows the 'Custom Service Forwarding Setup' configuration page. It has a section for 'Custom Service Forwarding' with an 'Enable' checkbox checked. Below this is a 'Settings' section with a table for adding service forwarding rules. The table has four columns: 'TCP Port', 'Server IP Address', 'Server Port', and a '+' button to add new rows.

TCP Port	Server IP Address	Server Port	
<input type="text"/>	<input type="text"/>	<input type="text"/>	<input type="button" value="+"/>

After clicking the **enable** checkbox, enter your TCP port for traffic heading to the router, and then specify the IP Address and Port of the server you wish to forward to the service to.

# Pepwave MAX and Surf User Manual

## 19.9 Service Passthrough

Service passthrough settings can be found at **Advanced>Misc. Settings>Service Passthrough**.

The screenshot shows the 'Service Passthrough Support' configuration page. It features a table with the following settings:

Service	Configuration
SIP	<input checked="" type="radio"/> Standard Mode <input type="radio"/> Compatibility Mode <input checked="" type="checkbox"/> Define custom signal ports 1. <input type="text"/> 2. <input type="text"/> 3. <input type="text"/>
H.323	<input checked="" type="checkbox"/> Enable
FTP	<input checked="" type="checkbox"/> Enable <input checked="" type="checkbox"/> Define custom control ports 1. <input type="text"/> 2. <input type="text"/> 3. <input type="text"/>
TFTP	<input checked="" type="checkbox"/> Enable
IPsec NAT-T	<input checked="" type="checkbox"/> Enable <input checked="" type="checkbox"/> Define custom ports 1. <input type="text"/> 2. <input type="text"/> 3. <input type="text"/> <input checked="" type="checkbox"/> Route IPsec Site-to-Site VPN via WAN 1

(Registered trademarks are copyrighted by their respective owner)

Some Internet services need to be specially handled in a multi-WAN environment. Pepwave routers can handle these services such that Internet applications do not notice being behind a multi-WAN router. Settings for service passthrough support are available here.

Service Passthrough Support	
<b>SIP</b>	Session initiation protocol, aka SIP, is a voice-over-IP protocol. The Pepwave router can act as a SIP application layer gateway (ALG) which binds connections for the same SIP session to the same WAN connection and translate IP address in the SIP packets correctly in NAT mode. Such passthrough support is always enabled, and there are two modes for selection: <b>Standard Mode</b> and <b>Compatibility Mode</b> . If your SIP server's signal port number is non-standard, you can check the box <b>Define custom signal ports</b> and input the port numbers to the text boxes.
<b>H.323</b>	With this option enabled, protocols that provide audio-visual communication sessions will be defined on any packet network and pass through the Pepwave router.
<b>FTP</b>	FTP sessions consist of two TCP connections; one for control and one for data. In a multi-WAN situation, they must be routed to the same WAN connection. Otherwise, problems will arise in transferring files. By default, the Pepwave router monitors TCP control connections on port 21 for any FTP connections and binds TCP connections of the same FTP session to the same WAN. If you have an FTP server listening on a port number other than 21, you can check <b>Define custom control ports</b> and enter the port numbers in the text boxes.
<b>TFTP</b>	The Pepwave router monitors outgoing TFTP connections and routes any incoming TFTP data packets back to the client. Select <b>Enable</b> if you want to enable TFTP passthrough support.
<b>IPsec NAT-T</b>	This field is for enabling the support of IPsec NAT-T passthrough. UDP ports 500, 4500, and 10000 are monitored by default. You may add more custom data ports that your IPsec system uses by checking <b>Define custom ports</b> . If the VPN contains IPsec site-to-site VPN traffic, check <b>Route IPsec Site-to-Site VPN</b> and choose the WAN connection



# Pepwave MAX and Surf User Manual

to route the traffic to.

## 19.10 GPS Forwarding

Using the GPS forwarding feature, some Pepwave routers can automatically send GPS reports to a specified server. To set up GPS forwarding, navigate to **Advanced>GPS Forwarding**.

GPS Forwarding				
Enable	<input checked="" type="checkbox"/>			
Server	Server IP Address / Host Name	Port	Protocol	Report Interval (s)
			UDP	1
GPS Report Format	<input checked="" type="radio"/> NMEA <input type="radio"/> TAIP			
NMEA Sentence Type	<input checked="" type="checkbox"/> GPRMC <input type="checkbox"/> GPGGA <input type="checkbox"/> GPVTG <input type="checkbox"/> GPGSA <input type="checkbox"/> GPGSV			
Vehicle ID (optional)	<input type="text"/>			

GPS Forwarding	
<b>Enable</b>	Check this box to turn on GPS forwarding.
<b>Server</b>	Enter the name/IP address of the server that will receive GPS data. Also specify a port number, protocol ( <b>UDP</b> or <b>TCP</b> ), and a report interval of between 1 and 10 seconds. Click  to save these settings.
<b>GPS Report Format</b>	Choose from NMEA or TAIP format for sending GPS reports.
<b>NMEA Sentence Type</b>	If you've chosen to send GPS reports in NMEA format, select one or more sentence types for sending the data ( <b>GPRMC</b> , <b>GPGGA</b> , <b>GPVTG</b> , <b>GPGSA</b> , and <b>GPGSV</b> ).
<b>Vehicle ID</b>	The vehicle ID will be appended in the last field of the NMEA sentence. Note that the NMEA sentence will become customized and non-standard.
<b>TAIP Sentence Type/TAIP ID (optional)</b>	If you've chosen to send GPS reports in TAIP format, select one or more sentence types for sending the data ( <b>PV—Position / Velocity Solution</b> and <b>CP—Compact Velocity Solution</b> ). You can also optionally include an ID number in the <b>TAIP ID</b> field.

# Pepwave MAX and Surf User Manual

## 20 AP Controller

The AP controller acts as a centralized controller of Pepwave AP devices. With this feature, users can customize and manage multiple APs from a single Pepwave router interface.

### Special Note

Each Pepwave router can control a limited number of routers without additional cost. To manage more, a Full Edition license is required. Please contact your Authorized Reseller or the Peplink Sales Team for more information and pricing details.

To configure, navigate to the **AP** tab.

### 20.1 Wireless SSID

This menu is the first one that appears after clicking the **AP** tab. This screen can also be reached by clicking **AP>Wireless SSID**. Note the appearance of this screen varies by model.

AP Controller	
AP Management	<input checked="" type="checkbox"/> Integrated AP <input checked="" type="checkbox"/> External AP
Permitted AP	<input type="radio"/> Any <input checked="" type="radio"/> Approved List
	<div style="border: 1px solid gray; height: 100px; width: 100%;"></div> <p>(One serial number per line)</p>

### AP Controller

#### AP Management

The AP controller for managing Pepwave APs can be enabled by checking this box. When this option is enabled, the AP controller will wait for management connections originating from APs over the LAN on TCP and UDP port 11753. It will also wait for captive portal connections on TCP port 443. An extended DHCP option, **CAPWAP Access Controller addresses** (field 138), will be added to the DHCP server. A local DNS record, **AP Controller**, will be added to the local DNS proxy.

#### Permitted AP

Access points to manage can be specified here. If **Any** is selected, the AP controller will manage any AP that reports to it. If **Approved List** is selected, only APs with serial numbers listed in the provided text box will be managed.

SSID	Security Policy	
PEPWAVE_8D1C	WPA/WPA2 - Personal	<input type="button" value="X"/>

# Pepwave MAX and Surf User Manual

Current SSID information appears in the **SSID** section. To edit an existing SSID, click its name in the list. To add a new SSID, click **Add**. Note that the following settings vary by model.

The screenshot shows a configuration window titled "SSID" with a close button in the top right. It is divided into three sections: "SSID Settings", "Security Settings", and "Access Control".

- SSID Settings:** Includes fields for SSID (PEPWAVE\_8D1C), VLAN ID (LAN (No VLAN)), Broadcast SSID (checked), Data Rate (Auto selected), Multicast Filter (unchecked), Multicast Rate (MCS8/MCS0/6M), IGMP Snooping (unchecked), Layer 2 Isolation (unchecked), and Band Steering (Disable).
- Security Settings:** Includes Security Policy (Open (No Encryption)).
- Access Control:** Includes Restricted Mode (None).

At the bottom right, there are "Save" and "Cancel" buttons.

## SSID Settings

<b>SSID</b>	This setting specifies the SSID of the virtual AP to be scanned by Wi-Fi clients.
<b>Enable</b>	Select <b>Yes</b> to enable the virtual AP.
<b>VLAN ID</b>	This setting specifies the VLAN ID to be tagged on all outgoing packets generated from this wireless network (i.e., packets that travel from the Wi-Fi segment through the Pepwave AP One unit to the Ethernet segment via the LAN port). The default value of this setting is <b>0</b> , which means VLAN tagging is disabled (instead of tagged with zero).
<b>Broadcast SSID</b>	This setting specifies whether or not Wi-Fi clients can scan the SSID of this wireless network. <b>Broadcast SSID</b> is enabled by default.
<b>Data Rate <sup>A</sup></b>	Select <b>Auto</b> to allow the Pepwave router to set the data rate automatically, or select <b>Fixed</b> and choose a rate from the displayed drop-down menu.
<b>Multicast Filter<sup>A</sup></b>	This setting enables the filtering of multicast network traffic to the wireless SSID.

# Pepwave MAX and Surf User Manual

<b>Multicast Rate<sup>A</sup></b>	This setting specifies the transmit rate to be used for sending multicast network traffic. The selected <b>Protocol</b> and <b>Channel Bonding</b> settings will affect the rate options and values available here.
<b>IGMP Snooping<sup>A</sup></b>	To allow the Pepwave router to listen to internet group management protocol (IGMP) network traffic, select this option.
<b>DHCP Option 82<sup>A</sup></b>	If you use a distributed DHCP server/relay environment, you can enable this option to provide additional information on the manner in which clients are physically connected to the network.
<b>Network Priority (QoS)<sup>A</sup></b>	Select from <b>Gold</b> , <b>Silver</b> , and <b>Bronze</b> to control the QoS priority of this wireless network's traffic.
<b>Layer 2 Isolation<sup>A</sup></b>	<b>Layer 2</b> refers to the second layer in the ISO Open System Interconnect model. When this option is enabled, clients on the same VLAN, SSID, or subnet are isolated to that VLAN, SSID, or subnet, which can enhance security. Traffic is passed to upper communication layer(s). By default, the setting is disabled.
<b>Band Steering<sup>A</sup></b>	Band steering allows the Pepwave router to steer AP clients from the 2.4GHz band to the 5GHz band for better usage of bandwidth. To make steering mandatory, select <b>Enforce</b> . To cause the Pepwave router to preferentially choose steering, select <b>Prefer</b> . The default for this setting is <b>Disable</b> .

<sup>A</sup> - Advanced feature. Click the  button on the top right-hand corner to activate.

Security Settings	
Security Policy	WPA2 - Personal ▼
Encryption	AES:CCMP
Shared Key	<input type="password" value="....."/> <input checked="" type="checkbox"/> Hide Characters

Security Settings	
<b>Security Policy</b>	This setting configures the wireless authentication and encryption methods. Available options are <b>Open (No Encryption)</b> , <b>WPA/WPA2 - Personal</b> , <b>WPA/WPA2 - Enterprise</b> and <b>Static WEP</b> .

Access Control	
Restricted Mode	Deny all except listed ▼
MAC Address List	<input type="text"/>

Access Control	
<b>Restricted Mode</b>	The settings allow administrator to control access using MAC address filtering. Available options are <b>None</b> , <b>Deny all except listed</b> , <b>Accept all except listed</b> , and <b>RADIUS MAC Authentication</b> .  When <b>WPA/WPA2 - Enterprise</b> is configured, RADIUS-based 802.1 x authentication is enabled. Under this configuration, the <b>Shared Key</b> option should be disabled. When using

# Pepwave MAX and Surf User Manual

this method, select the appropriate version using the **V1/V2** controls. The security level of this method is known to be very high.

When **WPA/WPA2- Personal** is configured, a shared key is used for data encryption and authentication. When using this configuration, the **Shared Key** option should be enabled. Key length must be between eight and 63 characters (inclusive). The security level of this method is known to be high.

The configuration of **Static WEP** parameters enables pre-shared WEP key encryption. Authentication is not supported by this method. The security level of this method is known to be weak.

**MAC Address List** Connection coming from the MAC addresses in this list will be either denied or accepted based the option selected in the previous field.

RADIUS Server Settings	Primary Server	Secondary Server
Host	<input type="text"/>	<input type="text"/>
Secret	<input type="text"/>	<input type="text"/>
Authentication Port	1812 <input type="button" value="Default"/>	1812 <input type="button" value="Default"/>
Accounting Port	1813 <input type="button" value="Default"/>	1813 <input type="button" value="Default"/>

## RADIUS Server Settings

<b>Host</b>	Enter the IP address of the primary RADIUS server and, if applicable, the secondary RADIUS server.
<b>Secret</b>	Enter the RADIUS shared secret for the primary server and, if applicable, the secondary RADIUS server.
<b>Authentication Port</b>	In field, enter the UDP authentication port(s) used by your RADIUS server(s) or click the <b>Default</b> button to enter <b>1812</b> .
<b>Accounting Port</b>	In field, enter the UDP accounting port(s) used by your RADIUS server(s) or click the <b>Default</b> button to enter <b>1813</b> .

# Pepwave MAX and Surf User Manual

## 20.2 Settings

On many Pepwave models, the AP settings screen (**AP>Settings**) looks similar to the example below:

AP Settings	
AP Profile Name	<input type="text"/>
SSID	<input type="checkbox"/> 2.4 GHz <input type="checkbox"/> 5 GHz <input type="checkbox"/> PEPLINK_01AA
Operating Country	United States
Preferred Frequency	<input checked="" type="radio"/> 2.4 GHz <input type="radio"/> 5 GHz
5 GHz Protocol	802.11n/ac Integrated AP supports 802.11na only.
5 GHz Channel Width	20/40 MHz
5 GHz Channel	Auto <input type="button" value="Edit"/> Channels: 36 40 44 48 ...
2.4 GHz Protocol	802.11ng
2.4 GHz Channel Width	20 MHz
2.4 GHz Channel	Auto <input type="button" value="Edit"/> Channels: 1 2 3 4 5 6 ...
Management VLAN ID	(No VLAN)
Operating Schedule	Always on
Power Boost	<input type="checkbox"/>
Output Power	Max
Maximum number of clients	0 (0: Unlimited)
Client Signal Strength Threshold	0 -95 dBm (0: Unlimited)
Beacon Rate	1 Mbps 6 Mbps will be used for 5 GHz radio
Beacon Interval	100 ms
DTIM	1 <input type="button" value="Default"/>
RTS Threshold	0 <input type="button" value="Default"/>
Fragmentation Threshold	0 (0: Disable) <input type="button" value="Default"/>
Distance / Time Converter	<input type="text" value="4050"/> m Note: Input distance for recommended values
Slot Time	<input type="radio"/> Auto <input checked="" type="radio"/> Custom <input type="text" value="9"/> $\mu$ s <input type="button" value="Default"/>
ACK Timeout	48 $\mu$ s <input type="button" value="Default"/>
Frame Aggregation	<input checked="" type="checkbox"/>
Aggregation Length	50000 <input type="button" value="Default"/>

### AP Settings

**AP Profile Name** This field specifies the name of this AP profile.

#### SSID

These buttons specify which wireless networks will use this AP profile. You can also select the frequencies at which each network will transmit. Please note that the Peplink Balance does not detect whether the AP is capable of transmitting at both frequencies. Instructions to transmit at unsupported frequencies will be ignored by the AP.

#### Operating

This drop-down menu specifies the national / regional regulations which the AP should

# Pepwave MAX and Surf User Manual

<b>Country</b>	<p>follow.</p> <ul style="list-style-type: none"> <li>• If a North American region is selected, RF channels 1 to 11 will be available and the maximum transmission power will be 26 dBm (400 mW).</li> <li>• If European region is selected, RF channels 1 to 13 will be available. The maximum transmission power will be 20 dBm (100 mW).</li> </ul> <p>NOTE: Users are required to choose an option suitable to local laws and regulations. Per FCC regulation, the country selection is not available on all models marketed in US. All US models are fixed to US channels only.</p>
<b>Preferred Frequency</b>	<p>These buttons determine the frequency at which access points will attempt to broadcast. This feature will only work for APs that can transmit at both 5.4GHz and 5GHz frequencies.</p>
<b>5 GHz Protocol</b>	<p>This section displays the 5 GHz protocols your APs are using.</p>
<b>5GHz Channel Bonding</b>	<p>There are three options: 20 MHz, 20/40 MHz, and 40 MHz. With this feature enabled, the Wi-Fi system can use two channels at once. Using two channels improves the performance of the Wi-Fi connection.</p>
<b>5 GHz Channel</b>	<p>This drop-down menu selects the 5 GHz 802.11 channel to be utilized. If <b>Auto</b> is set, the system will perform channel scanning based on the scheduled time set and choose the most suitable channel automatically.</p>
<b>2.4 GHz Protocol</b>	<p>This section displays the 2.4 GHz protocols your APs are using.</p>
<b>2.4 GHz Channel Bonding</b>	<p>There are three options: 20 MHz, 20/40 MHz, and 40 MHz. With this feature enabled, the Wi-Fi system can use two channels at once. Using two channels improves the performance of the Wi-Fi connection.</p>
<b>2.4 GHz Channel</b>	<p>This drop-down menu selects the 802.11 channel to be utilized. Available options are from 1 to 11 and from 1 to 13 for the North America region and Europe region, respectively. (Channel 14 is only available when the country is selected as Japan with protocol 802.11b.) If <b>Auto</b> is set, the system will perform channel scanning based on the scheduled time set and choose the most suitable channel automatically.</p>
<b>Management VLAN ID</b>	<p>This field specifies the VLAN ID to tag to management traffic, such as AP to AP controller communication traffic. The value is <b>0</b> by default, meaning that no VLAN tagging will be applied. NOTE: change this value with caution as alterations may result in loss of connection to the AP controller.</p>
<b>Operating Schedule</b>	<p>Choose from the schedules that you have defined in <b>System&gt;Schedule</b>. Select the schedule for the integrated AP to follow from the drop-down menu.</p>
<b>Power Boost<sup>A</sup></b>	<p>With this option enabled, the AP under this profile will transmit using additional power. Please note that using this option with several APs in close proximity will lead to increased interference.</p>
<b>Output Power<sup>A</sup></b>	<p>This drop-down menu determines the power at which the AP under this profile will broadcast. When fixed settings are selected, the AP will broadcast at the specified power level, regardless of context. When <b>Dynamic</b> settings are selected, the AP will adjust its power level based on its surrounding APs in order to maximize performance.</p> <p>The <b>Dynamic: Auto</b> setting will set the AP to do this automatically. Otherwise, the <b>Dynamic: Manual</b> setting will set the AP to dynamically adjust only of instructed to do so. If you have set <b>Dynamic:Manual</b>, you can go to <b>AP&gt;Toolbox&gt;Auto Power Adj.</b> to</p>

# Pepwave MAX and Surf User Manual

	give your AP further instructions.
<b>Max number of Clients<sup>A</sup></b>	This field determines the maximum clients that can be connected to APs under this profile.
<b>Client Signal Strength Threshold<sup>A</sup></b>	This field determines that maximum signal strength each individual client will receive. The measurement unit is megawatts.
<b>Beacon Rate<sup>A</sup></b>	This drop-down menu provides the option to send beacons in different transmit bit rates. The bit rates are <b>1Mbps</b> , <b>2Mbps</b> , <b>5.5Mbps</b> , <b>6Mbps</b> , and <b>11Mbps</b> .
<b>Beacon Interval<sup>A</sup></b>	This drop-down menu provides the option to set the time between each beacon send. Available options are <b>100ms</b> , <b>250ms</b> , and <b>500ms</b> .
<b>DTIM<sup>A</sup></b>	This field provides the option to set the frequency for beacon to include delivery traffic indication messages (DTIM). The interval unit is measured in milliseconds.
<b>RTS Threshold<sup>A</sup></b>	This field provides the option to set the minimum packet size for the unit to send an RTS using the RTS/CTS handshake. Setting <b>0</b> disables this feature.
<b>Fragmentation Threshold<sup>A</sup></b>	Determines the maximum size (in bytes) that each packet fragment will be broken down into. Set 0 to disable fragmentation.
<b>Distance/Time Converter<sup>A</sup></b>	Select the distance you want your Wi-Fi to cover in order to adjust the below parameters. Default values are recommended.
<b>Slot Time<sup>A</sup></b>	This field provides the option to modify the unit wait time before it transmits. The default value is <b>9µs</b> .
<b>ACK Timeout<sup>A</sup></b>	This field provides the option to set the wait time to receive acknowledgement packet before doing retransmission. The default value is <b>48µs</b> .
<b>Frame Aggregation<sup>A</sup></b>	With this feature enabled, throughput will be increased by sending two or more data frames in a single transmission.
<b>Frame Length</b>	This field is only available when <b>Frame Aggregation</b> is enabled. It specifies the frame length for frame aggregation. By default, it is set to <b>50000</b> .

<sup>A</sup> - Advanced feature. Click the  button on the top right-hand corner to activate.

Web Administration Settings (on External AP)	
Enable	<input checked="" type="checkbox"/>
Web Access Protocol	<input type="radio"/> HTTP <input checked="" type="radio"/> HTTPS
Management Port	<input type="text" value="443"/>
HTTP to HTTPS Redirection	<input checked="" type="checkbox"/>
Admin Username	<input type="text" value="admin"/>
Admin Password	<input type="text" value="25db591396e0"/> <input type="button" value="Generate"/>

## Web Administration Settings



# Pepwave MAX and Surf User Manual



<b>Enable</b>	Check the box to allow the Pepwave router to manage the web admin access information of the AP.
<b>Web Access Protocol</b>	These buttons specify the web access protocol used for accessing the web admin of the AP. The two available options are <b>HTTP</b> and <b>HTTPS</b> .
<b>Management Port</b>	This field specifies the management port used for accessing the device.
<b>HTTP to HTTPS Redirection</b>	This option will be available if you have chosen <b>HTTPS</b> as the <b>Web Access Protocol</b> . With this enabled, any HTTP access to the web admin will redirect to HTTPS automatically.
<b>Admin User Name</b>	This field specifies the administrator username of the web admin. It is set as <i>admin</i> by default.
<b>Admin Password</b>	This field allows you to specify a new administrator password. You may also click the <b>Generate</b> button and let the system generate a random password automatically.

Navigating to **AP>Settings** on some Pepwave models displays a screen similar to the one shown below:

 InControl management enabled. Settings can now be configured on [InControl](#).

Wi-Fi Radio Settings	
Operating Country	United States ▼
Wi-Fi Antenna	<input type="radio"/> Internal <input checked="" type="radio"/> External

Wi-Fi AP Settings 	
Protocol	802.11ng ▼
Channel	1 (2.412 GHz) ▼
Channel Width	Auto ▼
Output Power	Max ▼ <input type="checkbox"/> Boost
Beacon Rate 	1Mbps ▼
Beacon Interval 	100ms ▼
DTIM 	1
Slot Time 	9 μs
ACK Timeout 	48 μs
Frame Aggregation	<input checked="" type="checkbox"/> Enable
Guard Interval	<input type="radio"/> Short <input type="radio"/> Long

# Pepwave MAX and Surf User Manual

## Wi-Fi Radio Settings

### Operating Country

This option sets the country whose regulations the Pepwave router follows.

### Wi-Fi Antenna

Choose from the router's internal or optional external antennas, if so equipped.

## Important Note

Per FCC regulations, the country selection is not available on all models marketed in the US. All US models are fixed to US channels only.

## Wi-Fi AP Settings

### Protocol

This option allows you to specify whether 802.11b and/or 802.11g client association requests will be accepted. Available options are **802.11ng** and **802.11na**. By default, **802.11ng** is selected.

### Channel

This option allows you to select which 802.11 RF channel will be used. **Channel 1 (2.412 GHz)** is selected by default.

### Channel Width

**Auto (20/40 MHz)** and **20 MHz** are available. The default setting is **Auto (20/40 MHz)**, which allows both widths to be used simultaneously.

### Output Power

This option is for specifying the transmission output power for the Wi-Fi AP. There are 4 relative power levels available – **Max**, **High**, **Mid**, and **Low**. The actual output power will be bound by the regulatory limits of the selected country.

### Beacon Rate<sup>A</sup>

This option is for setting the transmit bit rate for sending a beacon. By default, **1Mbps** is selected.

### Beacon Interval<sup>A</sup>

This option is for setting the time interval between each beacon. By default, **100ms** is selected.

### DTIM<sup>A</sup>

This field allows you to set the frequency for the beacon to include a delivery traffic indication message. The interval is measured in milliseconds. The default value is set to **1 ms**.

### Slot Time<sup>A</sup>

This field is for specifying the wait time before the Surf SOHO transmits a packet. By default, this field is set to **9 µs**.

### ACK Timeout<sup>A</sup>

This field is for setting the wait time to receive an acknowledgement packet before performing a retransmission. By default, this field is set to **48 µs**.

### Frame Aggregation<sup>A</sup>

This option allows you to enable frame aggregation to increase transmission throughput.

### Guard Interval<sup>A</sup>

This setting allows choosing a short or long guard period interval for your transmissions.

<sup>A</sup> - Advanced feature, please click the  button on the top right-hand corner to activate.

## 20.3 Toolbox

Tools for managing firmware packs can be found at **AP>Toolbox**.

# Pepwave MAX and Surf User Manual

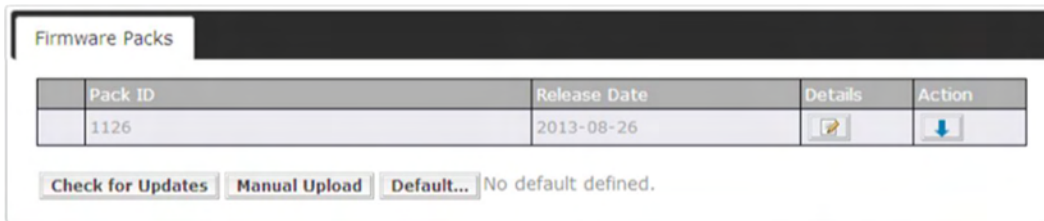

## Firmware Packs

Here, you can manage the firmware of your AP. Clicking on  will result in information regarding each firmware pack. To receive new firmware packs, you can click **Check for Updates** to download new packs, or you can click **Manual Upload** to manually upload a firmware pack. Click **Default** to define which firmware pack is default.

## 21 System Settings

### 21.1 Admin Security

There are two types of user accounts available for accessing the web admin: *admin* and *user*. They represent two user levels: the admin level has full administration access, while the user level is read-only. The user level can access only the device's status information; users cannot make any changes on the device.

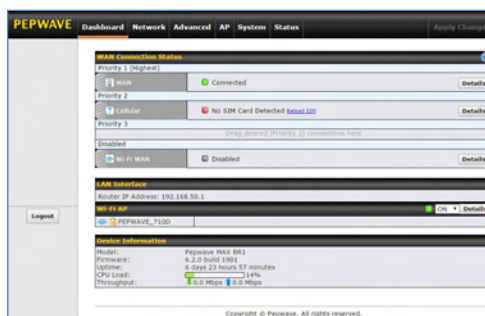

Admin account UI

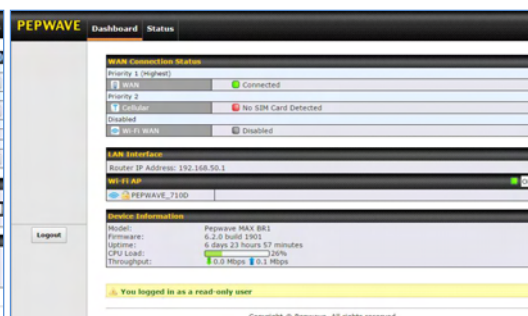

User account UI

# Pepwave MAX and Surf User Manual

A web login session will be logged out automatically when it has been idle longer than the **Web Session Timeout**. Before the session expires, you may click the **Logout** button in the web admin to exit the session.

**0 hours 0 minutes** signifies an unlimited session time. This setting should be used only in special situations, as it will lower the system security level if users do not log out before closing the browser. The **default** is 4 hours, 0 minutes.

For security reasons, after logging in to the web admin Interface for the first time, it is recommended to change the administrator password. Configuring the administration interface to be accessible only from the LAN can further improve system security. Administrative settings configuration is located at **System>Admin Security**.

Admin Settings	
Router Name	MAX_BR1_710D <span>hostname: max-br1-710d</span>
Admin User Name	admin
Admin Password	••••••••
Confirm Admin Password	••••••••
Read-only User Name	user
User Password	
Confirm User Password	
Web Session Timeout	4 Hours 0 Minutes
Authentication by RADIUS	<input checked="" type="checkbox"/> Enable
Auth Protocol	MS-CHAP v2
Auth Server	Port <span>Default</span>
Auth Server Secret	<input checked="" type="checkbox"/> Hide Characters
Auth Timeout	3 seconds
Accounting Server	Port <span>Default</span>
Accounting Server Secret	<input checked="" type="checkbox"/> Hide Characters
CLI SSH	<input checked="" type="checkbox"/> Enable
CLI SSH Port	8822 <span>Default</span>
CLI SSH Access	LAN/WAN
Security	HTTP
Web Admin Port	80 <span>Default</span>
Web Admin Access	LAN Only

# Pepwave MAX and Surf User Manual

Admin Settings	
<b>Router Name</b>	This field allows you to define a name for this Pepwave router. By default, <b>Router Name</b> is set as <b>MAX_XXXX</b> or <b>Surf_SOHO_XXXX</b> , where XXXX refers to the last 4 digits of the unit's serial number.
<b>Admin User Name</b>	<b>Admin User Name</b> is set as <i>admin</i> by default, but can be changed, if desired.
<b>Admin Password</b>	This field allows you to specify a new administrator password.
<b>Confirm Admin Password</b>	This field allows you to verify and confirm the new administrator password.
<b>Read-only User Name</b>	<b>Read-only User Name</b> is set as <i>user</i> by default, but can be changed, if desired.
<b>User Password</b>	This field allows you to specify a new user password. Once the user password is set, the read-only user feature will be enabled.
<b>Confirm User Password</b>	This field allows you to verify and confirm the new user password.
<b>Web Session Timeout</b>	This field specifies the number of hours and minutes that a web session can remain idle before the Pepwave router terminates its access to the web admin interface. By default, it is set to <b>4 hours</b> .
<b>Authentication by RADIUS</b>	With this box is checked, the web admin will authenticate using an external RADIUS server. Authenticated users are treated as either "admin" with full read-write permission or "user" with read-only access. Local admin and user accounts will be disabled. When the device is not able to communicate with the external RADIUS server, local accounts will be enabled again for emergency access. Additional authentication options will be available once this box is checked.
<b>Auth Protocol</b>	This specifies the authentication protocol used. Available options are <b>MS-CHAP v2</b> and <b>PAP</b> .
<b>Auth Server</b>	This specifies the access address and port of the external RADIUS server.
<b>Auth Server Secret</b>	This field is for entering the secret key for accessing the RADIUS server.
<b>Auth Timeout</b>	This option specifies the time value for authentication timeout.
<b>Accounting Server</b>	This specifies the access address and port of the external accounting server.
<b>Accounting Server Secret</b>	This field is for entering the secret key for accessing the accounting server.
<b>Network Connection</b>	This option is for specifying the network connection to be used for authentication. Users can choose from LAN, WAN, and VPN connections.
<b>CLI SSH</b>	The CLI (command line interface) can be accessed via SSH. This field enables CLI

# Pepwave MAX and Surf User Manual

	support. For additional information regarding CLI, please refer to <b>Section 21.16</b> .
<b>CLI SSH Port</b>	This field determines the port on which clients can access CLI SSH.
<b>CLI SSH Access</b>	This menu allows you to choose between granting access to LAN and WAN clients, or to LAN clients only.
<b>Security</b>	<p>This option is for specifying the protocol(s) through which the web admin interface can be accessed:</p> <ul style="list-style-type: none"> <li>• HTTP</li> <li>• HTTPS</li> <li>• HTTP/HTTPS</li> </ul>
<b>Web Admin Port</b>	This field is for specifying the port number on which the web admin interface can be accessed.
<b>Web Admin Access</b>	<p>This option is for specifying the network interfaces through which the web admin interface can be accessed:</p> <ul style="list-style-type: none"> <li>• LAN only</li> <li>• LAN/WAN</li> </ul> <p>If LAN/WAN is chosen, the <b>WAN Connection Access Settings</b> form will be displayed.</p>

## WAN Connection Access Settings

### Allowed Source IP Subnets

This field allows you to restrict web admin access only from defined IP subnets.

- **Any** - Allow web admin accesses to be from anywhere, without IP address restriction.
- **Allow access from the following IP subnets only** - Restrict web admin access only from the defined IP subnets. When this is chosen, a text input area will be displayed beneath:

The allowed IP subnet addresses should be entered into this text area. Each IP subnet must be in form of *w.x.y.z/m*, where *w.x.y.z* is an IP address (e.g., *192.168.0.0*), and *m* is the subnet mask in CIDR format, which is between 0 and 32 inclusively (For example, *192.168.0.0/24*).

To define multiple subnets, separate each IP subnet one in a line. For example:

# Pepwave MAX and Surf User Manual

- 192.168.0.0/24
- 10.8.0.0/16

**Allowed WAN  
IP Address(es)**

This is to choose which WAN IP address(es) the web server should listen on.

# Pepwave MAX and Surf User Manual

## 21.2 Firmware

Pepwave router firmware is upgradeable through the web admin interface. Firmware upgrade functionality is located at **System>Firmware**.

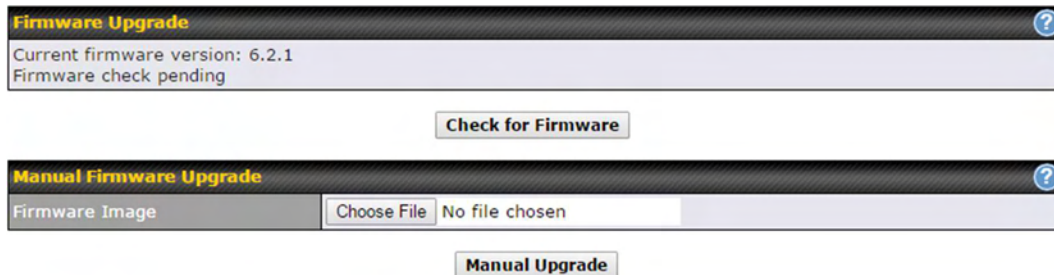

There are two ways to upgrade the unit. The first method is through an online download. The second method is to upload a firmware file manually.

To perform an online download, click on the **Check for Firmware** button. The Pepwave router will check online for new firmware. If new firmware is available, the Pepwave router will automatically download the firmware. The rest of the upgrade process will be automatically initiated.

You may also download a firmware image from the Peplink website and update the unit manually. To update using a firmware image, click **Choose File** to select the firmware file from the local computer, and then click **Manual Upgrade** to send the firmware to the Pepwave router. It will then automatically initiate the firmware upgrade process.

Please note that all Peplink devices can store two different firmware versions in two different partitions. A firmware upgrade will always replace the inactive partition. If you want to keep the inactive firmware, you can simply reboot your device with the inactive firmware and then perform the firmware upgrade.

### Important Note

The firmware upgrade process may not necessarily preserve the previous configuration, and the behavior varies on a case-by-case basis. Consult the release notes for the particular firmware version before installing. Do not disconnect the power during firmware upgrade process. Do not attempt to upload a non-firmware file or a firmware file that is not supported by Peplink. Upgrading the Pepwave router with an invalid firmware file will damage the unit and may void the warranty.

### Important Note

If the firmware is rolled back from 5.x to 4.x, the configurations will be lost.



# Pepwave MAX and Surf User Manual

## 21.3 Time

**Time Settings** enables the system clock of the Pepwave router to be synchronized with a specified time server. Time settings are located at **System>Time**.

Time Settings	
Time Zone	(GMT+07:00) Krasnoyarsk <input type="checkbox"/> Show all
Time Server	0.peplink.pool.ntp.org <span>Default</span>

Save

Time Settings	
<b>Time Zone</b>	This specifies the time zone (along with the corresponding Daylight Savings Time scheme). The <b>Time Zone</b> value affects the time stamps in the Pepwave router's event log and e-mail notifications. Check <b>Show all</b> to show all time zone options.
<b>Time Server</b>	This setting specifies the NTP network time server to be utilized by the Pepwave router.

## 21.4 Schedule

Enable and disable different functions (such as WAN connections, outbound policy, and firewalls at different times, based on a user-scheduled configuration profile. The settings for this are located at **System > Schedule**

Schedule			
Enabled			
Name	Time	Used by	
<u>Weekdays Only</u>	Weekdays only	-	

New Schedule

Enable scheduling, and then click on your schedule name or on the **New Schedule** button to begin.

# Pepwave MAX and Surf User Manual

**Edit schedule profile** ✕

---

**Schedule Settings**

Enable	<input checked="" type="checkbox"/>	The schedule function of those associated features will be lost if profile is disabled.
Name	<input type="text" value="Weekdays Only"/>	
Schedule	<input type="text" value="Weekdays only"/>	
Used by	You may go to supported feature settings page and set this profile as scheduler.	

---

**Schedule Map**

	Midnight	4am	8am	Noon	4pm	8pm
Sunday	x	x	x	x	x	x
Monday	✓	✓	✓	✓	✓	✓
Tuesday	✓	✓	✓	✓	✓	✓
Wednesday	✓	✓	✓	✓	✓	✓
Thursday	✓	✓	✓	✓	✓	✓
Friday	✓	✓	✓	✓	✓	✓
Saturday	x	x	x	x	x	x

Edit Schedule Profile	
<b>Enabling</b>	Click this checkbox to enable this schedule profile. Note that if this is disabled, then any associated features will also have their scheduling disabled.
<b>Name</b>	Enter your desired name for this particular schedule profile.
<b>Schedule</b>	Click the drop-down menu to choose pre-defined schedules as your starting point. Please note that upon selection, previous changes on the schedule map will be deleted.
<b>Schedule Map</b>	Click on the desired times to enable features at that time period. You can hold your mouse for faster entry.

## 21.5 Email Notification

Email notification functionality provides a system administrator with up-to-date information on network status. The settings for configuring email notifications are found at **System>Email Notification**.

# Pepwave MAX and Surf User Manual

Email Notification Setup	
Email Notification	<input checked="" type="checkbox"/> Enable
SMTP Server	smtp.mycompany.com <input checked="" type="checkbox"/> Require authentication
SSL Encryption	<input checked="" type="checkbox"/> (Note: any server certificate will be accepted)
SMTP Port	465 <input type="button" value="Default"/>
SMTP User Name	smtpuser
SMTP Password	••••••
Confirm SMTP Password	••••••
Sender's Email Address	admin@mycompany.com
Recipient's Email Address	system@mycompany.com staff@mycompany.com

## Email Notification Settings

<b>Email Notification</b>	This setting specifies whether or not to enable email notification. If <b>Enable</b> is checked, the Pepwave router will send email messages to system administrators when the WAN status changes or when new firmware is available. If <b>Enable</b> is not checked, email notification is disabled and the Pepwave router will not send email messages.
<b>SMTP Server</b>	This setting specifies the SMTP server to be used for sending email. If the server requires authentication, check <b>Require authentication</b> .
<b>SSL Encryption</b>	Check the box to enable SMTPS. When the box is checked, <b>SMTP Port</b> will be changed to <b>465</b> automatically.
<b>SMTP Port</b>	This field is for specifying the SMTP port number. By default, this is set to <b>25</b> ; when <b>SSL Encryption</b> is checked, the default port number will be set to <b>465</b> . You may customize the port number by editing this field. Click <b>Default</b> to restore the number to its default setting.
<b>SMTP User Name / Password</b>	This setting specifies the SMTP username and password while sending email. These options are shown only if <b>Require authentication</b> is checked in the <b>SMTP Server</b> setting.
<b>Confirm SMTP Password</b>	This field allows you to verify and confirm the new administrator password.
<b>Sender's Email Address</b>	This setting specifies the email address the Pepwave router will use to send reports.
<b>Recipient's Email Address</b>	This setting specifies the email address(es) to which the Pepwave router will send email notifications. For multiple recipients, separate each email addresses using the enter key.

After you have finished setting up email notifications, you can click the **Test Email Notification** button to test the settings before saving. After **Test Email Notification** is

# Pepwave MAX and Surf User Manual

clicked, you will see this screen to confirm the settings:

Test Email Notification	
SMTP Server	smtp.mycompany.com
SMTP Port	465
SMTP UserName	smtpuser
Sender's Email Address	admin@mycompany.com
Recipient's Email Address	system@mycompany.com staff@mycompany.com

Click **Send Test Notification** to confirm. In a few seconds, you will see a message with detailed test results.

**Test email sent. Email notification settings are not saved, it will be saved after clicked the 'Save' button.**

## Test Result

```
[INFO] Try email through connection #3
[<-] 220 ESMTTP
[->] EHLO balance
[<-] 250-smtp Hello balance [210.210.210.210]
250-SIZE 100000000
250-8BITMIME
250-PIPELINING
250-AUTH PLAIN LOGIN
250-STARTTLS
```

## 21.6 Event Log

Event log functionality enables event logging at a specified remote syslog server. The settings for configuring the remote system log can be found at **System>Event Log**.

Send Events to Remote Syslog Server	
Remote Syslog	<input checked="" type="checkbox"/>
Remote Syslog Host	

Push Events to Mobile Devices	
Push Events	<input checked="" type="checkbox"/>

## Event Log Settings

**Remote Syslog** This setting specifies whether or not to log events at the specified remote syslog server.

**Remote Syslog Host** This setting specifies the IP address or hostname of the remote syslog server.

# Pepwave MAX and Surf User Manual

The Pepwave router can also send push notifications to mobile devices that have our Mobile Router Utility installed. Check the box to activate this feature.

## Push Events



For more information on the Router Utility, go to:  
[www.peplink.com/products/router-utility](http://www.peplink.com/products/router-utility)

# Pepwave MAX and Surf User Manual

## 21.7 SNMP

SNMP or simple network management protocol is an open standard that can be used to collect information about the Pepwave router. SNMP configuration is located at **System>SNMP**.

SNMP Settings	
SNMP Device Name	MAX_HD2_8D1C
SNMP Port	161 <input type="button" value="Default"/>
SNMPv1	<input checked="" type="checkbox"/> Enable
SNMPv2c	<input checked="" type="checkbox"/> Enable
SNMPv3	<input checked="" type="checkbox"/> Enable
<input type="button" value="Save"/>	

Community Name	Allowed Source Network	Access Mode
No SNMPv1 / SNMPv2c Communities Defined		
<input type="button" value="Add SNMP Community"/>		

SNMPv3 User Name	Authentication / Privacy	Access Mode
No SNMPv3 Users Defined		
<input type="button" value="Add SNMP User"/>		

SNMP Settings	
<b>SNMP Device Name</b>	This field shows the router name defined at <b>System&gt;Admin Security</b> .
<b>SNMP Port</b>	This option specifies the port which SNMP will use. The default port is <b>161</b> .
<b>SNMPv1</b>	This option allows you to enable SNMP version 1.
<b>SNMPv2</b>	This option allows you to enable SNMP version 2.
<b>SNMPv3</b>	This option allows you to enable SNMP version 3.

To add a community for either SNMPv1 or SNMPv2, click the **Add SNMP Community** button in the **Community Name** table, upon which the following screen is displayed:

SNMP Community	
Community Name	My Company
Allowed Network	192.168.1.25 / 255.255.255.0 (/24) ▼
<input type="button" value="Save"/> <input type="button" value="Cancel"/>	

# Pepwave MAX and Surf User Manual

SNMP Community Settings	
<b>Community Name</b>	This setting specifies the SNMP community name.
<b>Allowed Source Subnet Address</b>	This setting specifies a subnet from which access to the SNMP server is allowed. Enter subnet address here (e.g., 192.168.1.0) and select the appropriate subnet mask.

To define a user name for SNMPv3, click **Add SNMP User** in the **SNMPv3 User Name**

SNMPv3 User	
User Name	SNMPUser
Authentication	SHA password
Privacy	DES privacypassword

Save Cancel

table, upon which the following screen is displayed:

SNMPv3 User Settings	
<b>User Name</b>	This setting specifies a user name to be used in SNMPv3.
<b>Authentication Protocol</b>	<p>This setting specifies via a drop-down menu one of the following valid authentication protocols:</p> <ul style="list-style-type: none"><li>• NONE</li><li>• MD5</li><li>• SHA</li></ul> <p>When MD5 or SHA is selected, an entry field will appear for the password.</p>
<b>Privacy Protocol</b>	<p>This setting specifies via a drop-down menu one of the following valid privacy protocols:</p> <ul style="list-style-type: none"><li>• NONE</li><li>• DES</li></ul> <p>When DES is selected, an entry field will appear for the password.</p>

# Pepwave MAX and Surf User Manual

## 21.8 InControl

InControl Management	
InControl Management 	<input checked="" type="checkbox"/> Allow InControl Management
Privately Host InControl	<input checked="" type="checkbox"/>
InControl Host	<input type="text"/>

InControl is a cloud-based service which allows you to manage all of your Peplink and Pepwave devices with one unified system. With it, you can generate reports, gather statistics, and configure your devices automatically. All of this is now possible with InControl.

When this check box is checked, the device's status information will be sent to the Peplink InControl system. This device's usage data and configuration will be sent to the system if you enable the features in the system.

Alternately, you could also privately host InControl. Simply check the box beside the "Privately Host InControl" option, and enter the IP Address of your InControl Host.

You can sign up for an InControl account at <https://incontrol2.peplink.com/>. You can register your devices under the account, monitor their status, see their usage reports, and receive offline notifications.

## 21.9 Configuration



# Pepwave MAX and Surf User Manual

Backing up Pepwave router settings immediately after successful completion of initial setup is strongly recommended. The functionality to download and upload Pepwave router settings is found at **System>Configuration**. Note that available options vary by model.

The image displays four sequential screenshots of the Pepwave web interface's configuration section. Each screenshot is separated by a horizontal line. 1. The first screenshot shows a header 'Restore Configuration to Factory Settings' with a question mark icon and a red 'Restore Factory Settings' button. 2. The second screenshot shows a header 'Download Active Configurations' with a question mark icon and a 'Download' button. 3. The third screenshot shows a header 'Upload Configurations' with a question mark icon, a 'Configuration File' label, a 'Browse...' button, the text 'No file selected.', and an 'Upload' button. 4. The fourth screenshot shows a header 'Upload Configurations from High Availability Pair' with a question mark icon, a 'Configuration File' label, a 'Browse...' button, the text 'No file selected.', and an 'Upload' button.

Configuration	
<b>Restore Configuration to Factory Settings</b>	The <b>Restore Factory Settings</b> button is to reset the configuration to factory default settings. After clicking the button, you will need to click the <b>Apply Changes</b> button on the top right corner to make the settings effective.
<b>Download Active Configurations</b>	Click <b>Download</b> to backup the current active settings.
<b>Upload Configurations</b>	To restore or change settings based on a configuration file, click <b>Choose File</b> to locate the configuration file on the local computer, and then click <b>Upload</b> . The new settings can then be applied by clicking the <b>Apply Changes</b> button on the page header, or you can cancel the procedure by pressing <b>discard</b> on the main page of the web admin interface.
<b>Upload Configurations from High Availability Pair</b>	In a high availability (HA) configuration, a Pepwave router can quickly load the configuration of its HA counterpart. To do so, click the <b>Upload</b> button. After loading the settings, configure the LAN IP address of the Pepwave router so that it is different from the HA counterpart.

# Pepwave MAX and Surf User Manual

## 21.10 Feature Add-ons

Some Pepwave routers have features that can be activated upon purchase. Once the purchase is complete, you will receive an activation key. Enter the key in the **Activation Key** field, click **Activate**, and then click **Apply Changes**.

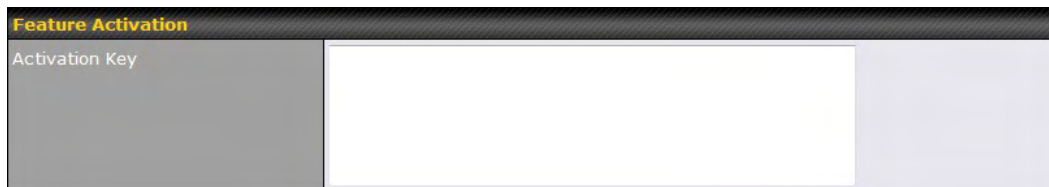

The screenshot shows a web interface titled "Feature Activation". It contains a label "Activation Key" followed by a large, empty text input field. The interface has a dark header bar with the title in yellow.

## 21.11 Reboot

This page provides a reboot button for restarting the system. For maximum reliability, the Pepwave router can equip with two copies of firmware. Each copy can be a different version. You can select the firmware version you would like to reboot the device with. The firmware marked with **(Running)** is the current system boot up firmware.

**Please note that a firmware upgrade will always replace the inactive firmware partition.**

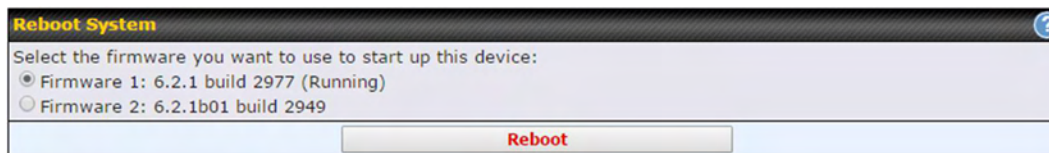

The screenshot shows a web interface titled "Reboot System" with a help icon in the top right. Below the title, it says "Select the firmware you want to use to start up this device:". There are two radio button options: "Firmware 1: 6.2.1 build 2977 (Running)" which is selected, and "Firmware 2: 6.2.1b01 build 2949". At the bottom, there is a "Reboot" button.

# Pepwave MAX and Surf User Manual

## 21.12 Ping

The ping test tool sends pings through a specified Ethernet interface or a SpeedFusion™ VPN connection. You can specify the number of pings in the field **Number of times**, to a maximum number of 10 times. **Packet Size** can be set to a maximum of 1472 bytes. The ping utility is located at **System>Tools>Ping**, illustrated below:

The screenshot displays the 'Ping' utility interface. The configuration section includes a 'Connection' dropdown set to 'WAN 1', a 'Destination' text box containing '10.10.10.1', a 'Packet Size' text box with '56', and a 'Number of times' slider set to '5'. Below the configuration are 'Start' and 'Stop' buttons. The 'Results' section shows a 'Clear Log' button and the following output:

```
PING 10.10.10.1 (10.10.10.1) from 10.88.3.158 56(84) bytes of data:
64 bytes from 10.10.10.1: icmp_req=1 ttl=62 time=27.6 ms
64 bytes from 10.10.10.1: icmp_req=2 ttl=62 time=26.5 ms
64 bytes from 10.10.10.1: icmp_req=3 ttl=62 time=28.9 ms
64 bytes from 10.10.10.1: icmp_req=4 ttl=62 time=28.3 ms
64 bytes from 10.10.10.1: icmp_req=5 ttl=62 time=27.7 ms

--- 10.10.10.1 ping statistics ---
5 packets transmitted, 5 received, 0% packet loss, time 4005ms
rtt min/avg/max/mdev = 26.516/27.855/28.933/0.814 ms
```

### Tip

A system administrator can use the ping utility to manually check the connectivity of a particular LAN/WAN connection.

# Pepwave MAX and Surf User Manual

## 21.13 Traceroute Test

The traceroute test tool traces the routing path to the destination through a particular Ethernet interface or a SpeedFusion™ connection. The traceroute test utility is located at **System>Tools>Traceroute**.

Traceroute	
Connection	WAN 1
Destination	64.233.189.99

Results		Clear Log
Traceroute to 64.233.189.99 (204.233.189.99), 30 hops max, 90 bytes packet size		
0	10.0.0.1 (10.0.0.1) 0.000 ms	
1	10.0.0.1 (10.0.0.1) 0.000 ms	
2	10.0.0.1 (10.0.0.1) 0.000 ms	
3	10.0.0.1 (10.0.0.1) 0.000 ms	
4	10.0.0.1 (10.0.0.1) 0.000 ms	
5	10.0.0.1 (10.0.0.1) 0.000 ms	
6	10.0.0.1 (10.0.0.1) 0.000 ms	
7	10.0.0.1 (10.0.0.1) 0.000 ms	
8	10.0.0.1 (10.0.0.1) 0.000 ms	
9	10.0.0.1 (10.0.0.1) 0.000 ms	
10	10.0.0.1 (10.0.0.1) 0.000 ms	
11	10.0.0.1 (10.0.0.1) 0.000 ms	
12	10.0.0.1 (10.0.0.1) 0.000 ms	
13	10.0.0.1 (10.0.0.1) 0.000 ms	
14	10.0.0.1 (10.0.0.1) 0.000 ms	
15	10.0.0.1 (10.0.0.1) 0.000 ms	
16	10.0.0.1 (10.0.0.1) 0.000 ms	
17	10.0.0.1 (10.0.0.1) 0.000 ms	
18	10.0.0.1 (10.0.0.1) 0.000 ms	
19	10.0.0.1 (10.0.0.1) 0.000 ms	
20	10.0.0.1 (10.0.0.1) 0.000 ms	
21	10.0.0.1 (10.0.0.1) 0.000 ms	
22	10.0.0.1 (10.0.0.1) 0.000 ms	
23	10.0.0.1 (10.0.0.1) 0.000 ms	
24	10.0.0.1 (10.0.0.1) 0.000 ms	
25	10.0.0.1 (10.0.0.1) 0.000 ms	
26	10.0.0.1 (10.0.0.1) 0.000 ms	
27	10.0.0.1 (10.0.0.1) 0.000 ms	
28	10.0.0.1 (10.0.0.1) 0.000 ms	
29	10.0.0.1 (10.0.0.1) 0.000 ms	
30	10.0.0.1 (10.0.0.1) 0.000 ms	

**Tip**

A system administrator can use the traceroute utility to analyze the connection path of a LAN/WAN connection.

## 21.14 PepVPN Test

The **PepVPN Test** tool can help to test the throughput between different VPN peers. You can define the **Test Type**, **Direction**, and **Duration** of the test, and press **Go!** to perform the throughput test. The VPN test utility is located at **System>Tools>PepVPN Test**, illustrated as follows:

PepVPN Throughput Test	
Profile	NY Office
Type	<input checked="" type="radio"/> TCP <input type="radio"/> UDP
Direction	<input checked="" type="radio"/> Upload <input type="radio"/> Download
Duration	10 seconds (5 - 600)

Results
(Empty)

# Pepwave MAX and Surf User Manual

## 21.15 Wake-on-LAN

Peplink routers can send special “magic packets” to any client specified from the Web UI. To access this feature, navigate to **System > Tools > Wake-on-LAN**

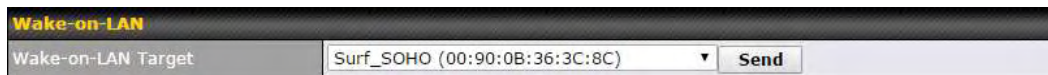

Select a client from the drop-down list and click **Send** to send a “magic packet”

## 21.16 CLI (Command Line Interface Support)

The CLI (command line interface) can be accessed via SSH. This field enables CLI support. The below settings specify which TCP port and which interface(s) should accept remote SSH CLI access. The user name and password used for remote SSH CLI access are the same as those used for web admin access.



# Pepwave MAX and Surf User Manual

## 22 Status

### 22.1 Device

System information is located at **Status>Device**.

System Information	
Router Name	MAX_HD2_8D1C
Model	Pepwave MAX HD2
Hardware Revision	2
Serial Number	2830-A48A-8D1C
Firmware	6.2.0 build 2891
PepVPN Version	4.0.0
Modem Support Version	1017 ( <a href="#">Modem Support List</a> )
Host Name	max-hd2-8d1c
Uptime	7 days 50 minutes
System Time	Mon Feb 23 11:14:13 WET 2015
Diagnostic Report	<a href="#">Download</a>
Remote Assistance	<a href="#">Turn on</a>

System Information	
<b>Router Name</b>	This is the name specified in the <b>Router Name</b> field located at <b>System&gt;Admin Security</b> .
<b>Model</b>	This shows the model name and number of this device.
<b>Product Code</b>	If your model uses a product code, it will appear here.
<b>Hardware Revision</b>	This shows the hardware version of this device.
<b>Serial Number</b>	This shows the serial number of this device.
<b>Firmware</b>	This shows the firmware version this device is currently running.
<b>PepVPN Version</b>	This shows the current PepVPN version.
<b>Modem Support Version</b>	This shows the modem support version. For a list of supported modems, click <b>Modem Support List</b> .
<b>Host Name</b>	The host name assigned to the Pepwave router appears here.
<b>Uptime</b>	This shows the length of time since the device has been rebooted.
<b>System Time</b>	This shows the current system time.
<b>Diagnostic Report</b>	The <b>Download</b> link is for exporting a diagnostic report file required for system investigation.

# Pepwave MAX and Surf User Manual

## Remote Assistance

Click **Turn on** to enable remote assistance.

Interface	MAC Address
LAN	00:1A:DD:BD:54:40
WAN 1	00:1A:DD:BD:54:41
WAN 2	00:1A:DD:BD:54:42

The second table shows the MAC address of each LAN/WAN interface connected. To view your device's End User License Agreement (EULA), click .

## Important Note

If you encounter issues and would like to contact the Pepwave Support Team (<http://www.pepwave.com/contact/>), please download the diagnostic report file and attach it along with a description of your issue. In Firmware 5.1 or before, the diagnostic report file can be obtained at **System>Reboot**.

### 22.1.1 GPS Data

The MAX HD2 and HD2 IP67 automatically store up to seven days of GPS location data in GPS eXchange format (GPX). To review this data using third-party applications, click **Status>Device** and then download your GPX file.

The Pepwave MAX BR1, HD2, and HD2 IP67 export real-time location data in NMEA format through the LAN IP address at TCP port 60660. It is accessible from the LAN or over a SpeedFusion connection. To access the data via a virtual serial port, install a virtual serial port driver. Visit <http://www.peplink.com/index.php?view=faq&id=294> to download the driver.

# Pepwave MAX and Surf User Manual

## 22.2 Active Sessions

Information on active sessions can be found at **Status>Active Sessions>Overview**.

Service	Inbound Sessions	Outbound Sessions
<a href="#">AIM/ICQ</a>	0	1
<a href="#">Bittorrent</a>	0	32
<a href="#">DNS</a>	0	51
<a href="#">Flash</a>	0	1
<a href="#">HTTPS</a>	0	76
<a href="#">Jabber</a>	0	5
<a href="#">MSN</a>	0	11
<a href="#">NTP</a>	0	4
<a href="#">QQ</a>	0	1
<a href="#">Remote Desktop</a>	0	3
<a href="#">SSH</a>	0	12
<a href="#">SSL</a>	0	64
<a href="#">XMPP</a>	0	4
<a href="#">Yahoo</a>	0	1

Interface	Inbound Sessions	Outbound Sessions
<a href="#">WAN 1</a>	0	176
<a href="#">WAN 2</a>	0	32
<a href="#">Wi-Fi WAN</a>	0	51
<a href="#">Cellular 1</a>	0	64
<a href="#">Cellular 2</a>	0	0
<a href="#">USB</a>	0	0

**Top Clients**

Client IP Address	Total Sessions
10.9.66.66	1069
10.9.98.144	147
10.9.2.18	63
10.9.66.14	56
10.9.2.26	33

This screen displays the number of sessions initiated by each application. Click on each service listing for additional information. This screen also indicates the number of sessions initiated by each WAN port. In addition, you can see which clients are initiating the most sessions.



# Pepwave MAX and Surf User Manual

You can also perform a filtered search for specific sessions. You can filter by subnet, port, protocol, and interface. To perform a search, navigate to **Status>Active Sessions>Search**.

Overview Search

Session data captured within one minute. [Refresh](#)

IP / Subnet	Source or Destination ▾	255.255.255.255 (/32) ▾
Port	Source or Destination ▾	
Protocol / Service	TCP ▾	
Interface	<input type="checkbox"/> WAN 1 <input type="checkbox"/> WAN 2 <input type="checkbox"/> Wi-Fi WAN <input type="checkbox"/> Cellular 1 <input type="checkbox"/> Cellular 2 <input type="checkbox"/> USB <input type="checkbox"/> VPN	
<input type="button" value="Search"/>		

**Outbound**

Protocol	Source IP	Destination IP	Service	Interface	Idle Time
No sessions					

Total searched results: 0

**Inbound**

Protocol	Source IP	Destination IP	Service	Interface	Idle Time
No sessions					

Total searched results: 0

**Transit**

Protocol	Source IP	Destination IP	Service	Interface	Idle Time
No sessions					

Total searched results: 0

This **Active Sessions** section displays the active inbound/outbound sessions of each WAN connection on the Pepwave router. A filter is available to sort active session information. Enter a keyword in the field or check one of the WAN connection boxes for filtering.

# Pepwave MAX and Surf User Manual

## 22.3 Client List

The client list table is located at **Status>Client List**. It lists DHCP and online client IP addresses, names (retrieved from the DHCP reservation table or defined by users), current download and upload rate, and MAC address.

Clients can be imported into the DHCP reservation table by clicking the  button on the right. You can update the record after import by going to **Network>LAN**.



IP Address	Name	Download (kbps)	Upload (kbps)	MAC Address	Import
192.168.1.100		0	0	00:50:56:99:E1:76	

Scale:  kbps  Mbps

If the PPTP server (see **Section 19.2**), SpeedFusion™ (see **Section 12.1**), or AP controller (see **Section 20**) is enabled, you may see the corresponding connection name listed in the **Name** field.

## 22.4 WINS Client

The WINS client list table is located at **Status>WINS Client**.

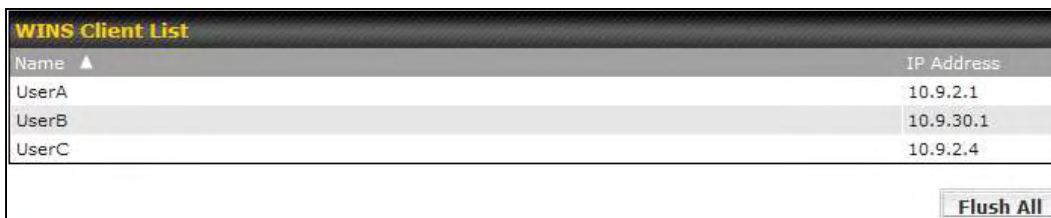

Name	IP Address
UserA	10.9.2.1
UserB	10.9.30.1
UserC	10.9.2.4



The WINS client table lists the IP addresses and names of WINS clients. This option will only be available when you have enabled the WINS server (navigation: **Network>Interfaces>LAN**). The names of clients retrieved will be automatically matched into the Client List (see previous section). Click **Flush All** to flush all WINS client records.

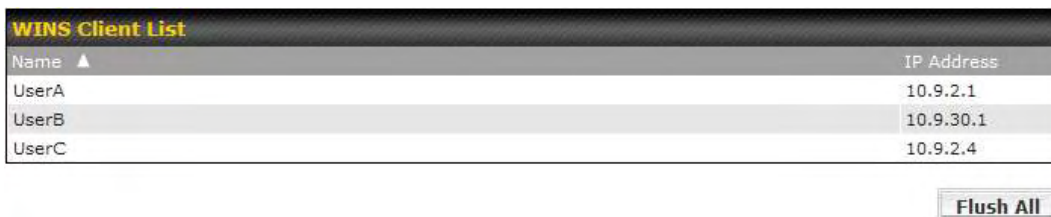

Name	IP Address
UserA	10.9.2.1
UserB	10.9.30.1
UserC	10.9.2.4



## 22.5 UPnP / NAT-PMP

The table that shows the forwarded ports under UPnP and NAT-PMP protocols is located at **Status>UPnP/NAT-PMP**. This section appears only if you have enabled UPnP / NAT-PMP as mentioned in **Section 16.1.1**.

Forwarded Ports						
External	Internal	Internal Address	Type	Protocol	Description	
47453	3392	192.168.1.100	UPnP	UDP	Application 031	
35892	11265	192.168.1.50	NAT-PMP	TCP	NAT-PMP 58	
4500	3560	192.168.1.20	UPnP	TCP	Application 013	
5921	236	192.168.1.30	UPnP	TCP	Application 047	
22409	8943	192.168.1.70	NAT-PMP	UDP	NAT-PMP 97	
2388	27549	192.168.1.40	UPnP	TCP	Application 004	

Click  to delete a single UPnP / NAT-PMP record in its corresponding row. To delete all records, click **Delete All** on the right-hand side below the table.

### Important Note

UPnP / NAT-PMP records will be deleted immediately after clicking the button  or **Delete All**, without the need to click **Save** or **Confirm**.

## 22.6 SpeedFusion Status

Current SpeedFusion™ status information is located at **Status>SpeedFusion™**. Details about SpeedFusion™ connection peers appears as below:

PepVPN with SpeedFusion - Remote Peer Details				<input type="checkbox"/> Show disconnected profiles	
Search					
Remote Peer	Profile	Information			
 ADA0-FFFC-11F8	FH	192.168.77.0/24			
 3ED2-8F63-1824	380-5 - NO NAT	192.168.3.0/24			

Click on the corresponding peer name to explore the WAN connection(s) status and subnet information of each VPN peer.

# Pepwave MAX and Surf User Manual

Remote Peer	Profile	Information
ADA0-FFFC-11F8	FH	192.168.77.0/24
WAN 1	Rx: < 1 kbps Tx: < 1 kbps	Drop rate: 0.0 pkt/s Latency: 1 ms
WAN 2	Rx: < 1 kbps Tx: < 1 kbps	Drop rate: 0.0 pkt/s Latency: 1 ms
WAN 3	Rx: < 1 kbps Tx: < 1 kbps	Drop rate: 0.0 pkt/s Latency: 1 ms
Total	Rx: < 1 kbps Tx: 1.1 kbps	Drop rate: 0.0 pkt/s
3ED2-8F63-1824	380-5 - NO NAT	192.168.3.0/24
WAN 1	Rx: < 1 kbps Tx: < 1 kbps	Drop rate: 0.0 pkt/s Latency: 4 ms
WAN 2	Rx: < 1 kbps Tx: < 1 kbps	Drop rate: 0.0 pkt/s Latency: 4 ms
WAN 3	Rx: < 1 kbps Tx: < 1 kbps	Drop rate: 0.0 pkt/s Latency: 4 ms
Total	Rx: 1.6 kbps Tx: < 1 kbps	Drop rate: 0.0 pkt/s

Click the  button for a chart displaying real-time throughput, latency, and drop-rate information for each WAN connection.

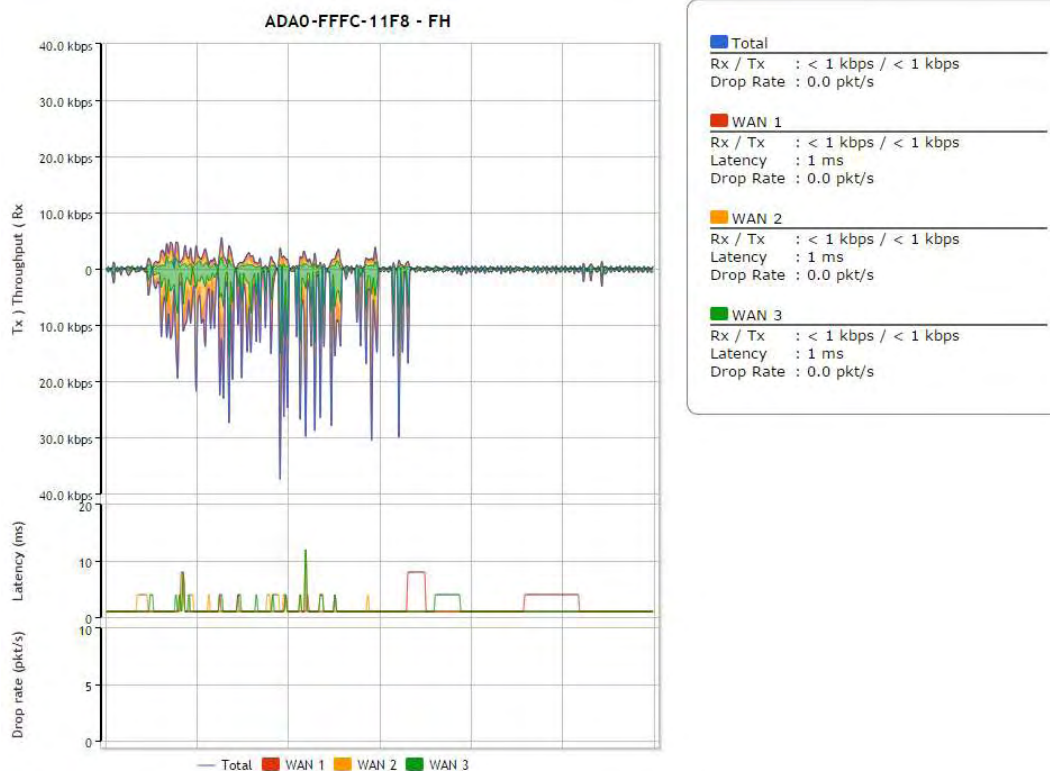

When pressing the  button, the following menu will appear:

# Pepwave MAX and Surf User Manual

### PepVPN performance analysis - 9B0A-A29B-2931



PepVPN Test:  
Check the general TCP/UDP throughput.



PepVPN Analyzer:  
Check the uplink performance of each tunnel.

Warning: PepVPN Analyzer will temporarily interrupt VPN connectivity and will restore after test.

Close



PepVPN Test:  
Check the general TCP/UDP throughput.

After clicking the icon, the following menu appears:

#### Configuration

Type	<input checked="" type="radio"/> TCP <input type="radio"/> UDP	Start
Direction	<input checked="" type="radio"/> Upload <input type="radio"/> Download	
Duration	10 seconds (5 - 600)	

#### WAN Statistics

WAN 1	Rx: 2.5 kbps	Tx: 5.3 kbps	Drop rate: 0.0 pkt/s	Latency: 186 ms
WAN 3	Rx: n/a	Tx: n/a	Drop rate: n/a	Latency: n/a
WAN 4	Rx: n/a	Tx: n/a	Drop rate: n/a	Latency: n/a
Total	Rx: 2.5 kbps	Tx: 5.3 kbps	Drop rate: 0.0 pkt/s	Latency: 186 ms

Select the L2 protocol (TCP/UDP), direction, and duration and click the **Start** button to begin the general throughput test.

#### Results

0.1250 MB / 1.00 sec = 1.0485 Mbps
1.0000 MB / 1.00 sec = 8.3888 Mbps
1.3125 MB / 1.00 sec = 11.0098 Mbps
3.0000 MB / 1.00 sec = 25.1465 Mbps
5.6875 MB / 1.00 sec = 47.7473 Mbps
6.0625 MB / 1.00 sec = 50.8562 Mbps
4.9375 MB / 1.00 sec = 41.4188 Mbps
4.5000 MB / 1.00 sec = 37.7487 Mbps
5.0000 MB / 1.00 sec = 41.9438 Mbps
5.6875 MB / 1.00 sec = 47.7099 Mbps
37.3167 MB / 10.05 sec = 31.1504 Mbps 8 %TX 9 %RX 47 retrans 132.62 msRTT
TEST DONE

# Pepwave MAX and Surf User Manual



PepVPN Analyzer:  
Check the uplink performance of each tunnel.

The bandwidth bonding feature of PepVPN occurs when multiple WAN lines from one end merge with multiple WAN lines from the other end. For this to happen, each WAN line needs to form a connection with all the WAN lines on the opposite end. The function of the PepVPN analyzer is to report the throughput, packet loss, and latency of all possible combinations of connections. **Please note that the PepVPN Analyzer will temporarily interrupt VPN connectivity and will restore after test.**

After clicking the icon, the analyzer will require several minutes to perform its analysis depending the number of WAN links in the SpeedFusion™ Tunnel. Once the test is complete, the report will appear:

Results							
Estimated time: 150 s Time remaining: 0 s							
100%							
Local WAN1 > Remote WAN3	Local WAN1 > Remote WAN4	Local WAN1 > Remote WAN5	Local WAN1 > Remote WAN6	Tx Avg. (Mbps)	Tx Max. (Mbps)	Packet loss (%)	RTT (ms)
O				5.87	16.95	0.76	420.51
	O			20.72	26.39	1.59	29.89
		O		30.10	43.69	2.24	29.61
			O	45.01	55.93	2.16	28.24
O	O			24.87	33.56	0.86	49.86
O		O		19.30	31.28	0.01	49.78
	O	O		18.59	30.41	2.08	39.78
O	O	O		20.56	34.60	0.00	38.11
O			O	36.70	59.16	2.64	42.06
	O		O	19.98	30.40	4.40	38.01
O	O		O	31.63	42.99	0.72	37.99
		O	O	36.88	55.78	2.60	33.89
O		O	O	38.30	47.89	0.01	29.98
	O	O	O	33.21	55.23	2.69	30.48
O	O	O	O	30.02	46.66	3.77	28.68

"O" indicates that specific WAN / Tunnel is active for that particular test.

"Tx Avg." is the averaged throughput across the full 10 seconds time, while "Tx Max." is the averaged throughput of the fastest 30% of time.

# Pepwave MAX and Surf User Manual

## 22.7 Event Log

Event log information is located at **Status>Event Log**.



The screenshot shows the 'Device Event Log' interface. At the top, there is a tab labeled 'Device Event Log' and a checkbox for 'Auto Refresh' which is checked. Below this is a table of log entries. The entries are as follows:

Timestamp	Event Description
Feb 17 04:43:26	System: Changes applied
Feb 16 10:27:01	System: Time synchronization successful
Feb 16 10:26:25	WAN: WAN 1 connected (10.88.3.158)
Feb 16 10:26:01	WAN: Priority changed (Priority 1 - WAN 1, WAN 2 / Priority 2 - Cellular 1, Cellular 2 / Disabled - Wi-Fi WAN)
Feb 16 10:25:40	System: Started up (6.2.0 build 2891)
Feb 16 10:17:27	System: Changes applied
Feb 16 10:17:00	System: Time synchronization successful
Feb 16 10:19:23	WAN: WAN 1 connected (10.88.3.158)
Feb 16 10:18:58	WAN: Priority changed (Priority 1 - WAN 1, WAN 2 / Priority 2 - Cellular 1, Cellular 2 / Disabled - Wi-Fi WAN)
Feb 16 10:18:37	System: Started up (6.2.0.201501210247-r12145 build)

At the bottom right of the log area, it says 'End of log'. Below the log area is a 'Clear Log' button.

The log section displays a list of events that has taken place on the Pepwave router. Check **Auto Refresh** to refresh log entries automatically. Click the **Clear Log** button to clear the log.

## 22.8 Bandwidth

This section shows bandwidth usage statistics and is located at **Status>Bandwidth**. Bandwidth usage at the LAN while the device is switched off (e.g., LAN bypass) is neither recorded nor shown.

# Pepwave MAX and Surf User Manual

## 22.8.1 Real-Time

The **Data transferred since installation** table indicates how much network traffic has been processed by the device since the first bootup. The **Data transferred since last reboot** table indicates how much network traffic has been processed by the device since the last bootup.

Data transferred since installation (Sun Oct 10 05:56:02 PST 2010)

	Download	Upload	Total
All WAN Connections	216.68 GB	91.70 GB	308.38 GB

Data transferred since last reboot

[\[ Hide Details \]](#)

	Download	Upload	Total
All WAN Connections	0.74 GB	0.63 GB	1.37 GB
WAN1	0.67 GB	0.61 GB	1.28 GB
WAN2	0.07 GB	0.02 GB	0.09 GB

Aggregated Transfer

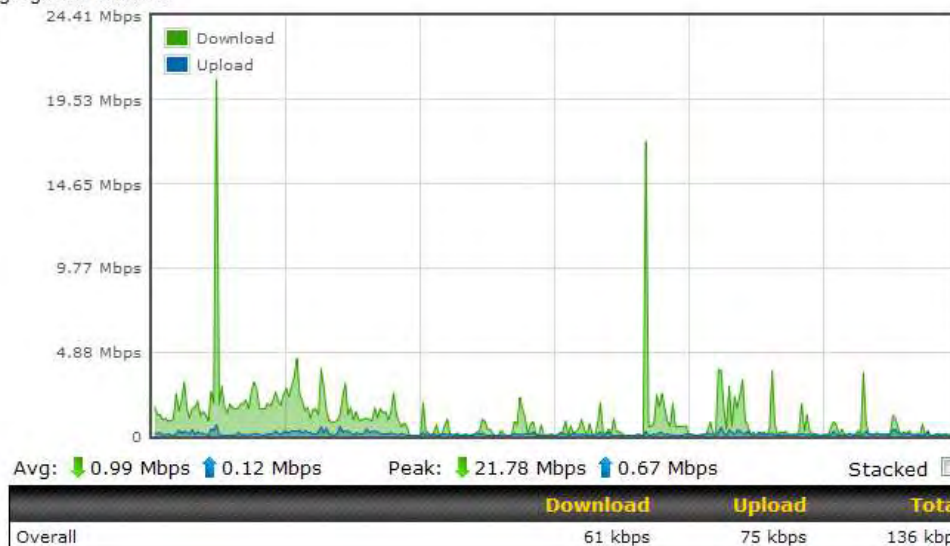



# Pepwave MAX and Surf User Manual

## 22.8.2 Hourly

This page shows the hourly bandwidth usage for all WAN connections, with the option of viewing each individual connection. Select the desired connection to check from the drop-down menu.

**Hourly Usage**

Connection: All WAN

Scale:  MB  GB

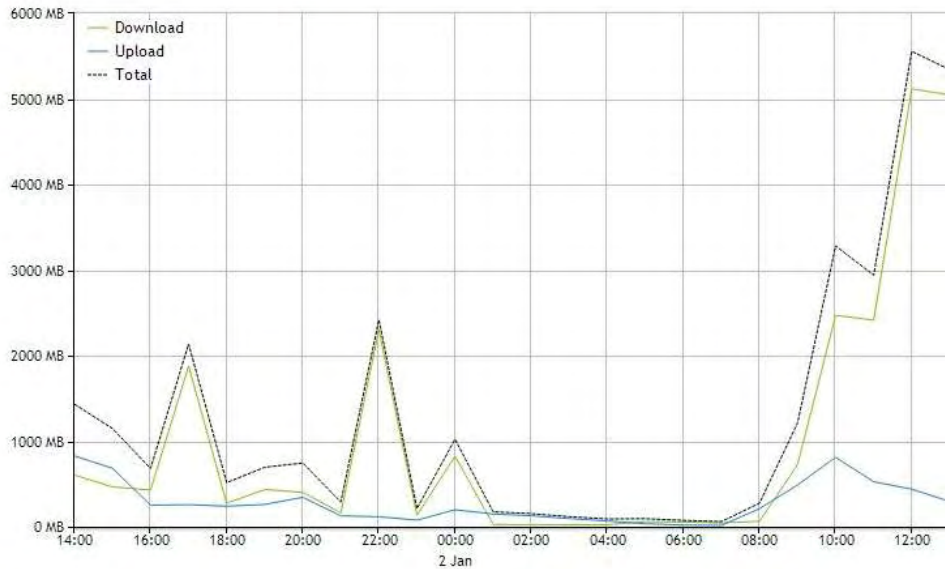

Date	Download	Upload	Total
<a href="#">13:00</a>	5 047 MB	295 MB	5 342 MB
<a href="#">12:00</a>	5 117 MB	439 MB	5 556 MB
<a href="#">11:00</a>	2 414 MB	526 MB	2 940 MB
<a href="#">10:00</a>	2 470 MB	812 MB	3 282 MB
<a href="#">09:00</a>	725 MB	488 MB	1 213 MB
<a href="#">08:00</a>	64 MB	211 MB	275 MB

## 22.8.3 Daily

# Pepwave MAX and Surf User Manual

This page shows the daily bandwidth usage for all WAN connections, with the option of viewing each individual connection.

Select the connection to check from the drop-down menu. If you have enabled the **Bandwidth Monitoring** feature, the **Current Billing Cycle** table for that WAN connection will be displayed.

Click on a date to view the client bandwidth usage of that specific date. This feature is not available if you have selected to view the bandwidth usage of only a particular WAN connection. The scale of the graph can be set to display megabytes (**MB**) or gigabytes (**GB**).

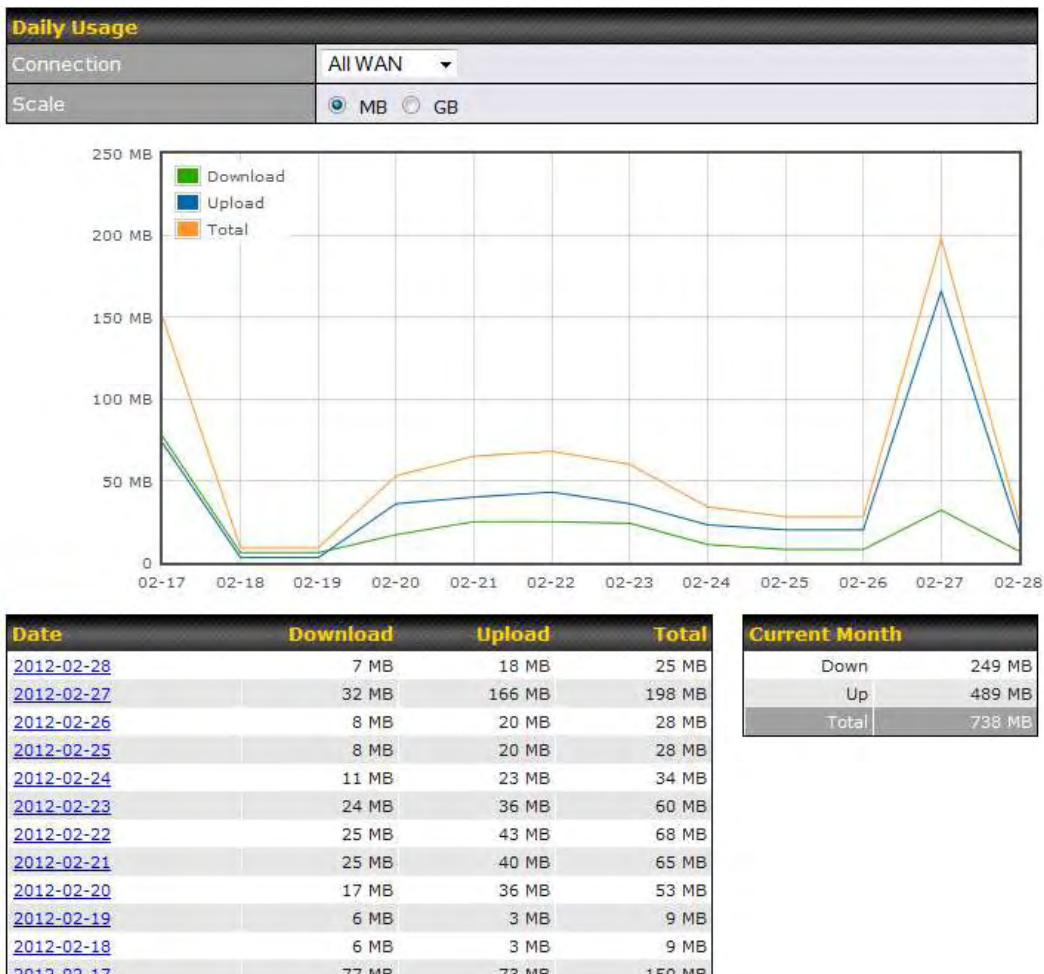

All WAN Daily Bandwidth Usage

# Pepwave MAX and Surf User Manual

## 22.8.4 Monthly

This page shows the monthly bandwidth usage for each WAN connection. If you have enabled the **Bandwidth Monitoring** feature, you can check the usage of each particular connection and view the information by **Billing Cycle** or by **Calendar Month**.

Click the first two rows to view the client bandwidth usage in the last two months. This feature is not available if you have chosen to view the bandwidth of an individual WAN connection. The scale of the graph can be set to display megabytes (**MB**) or gigabytes (**GB**).

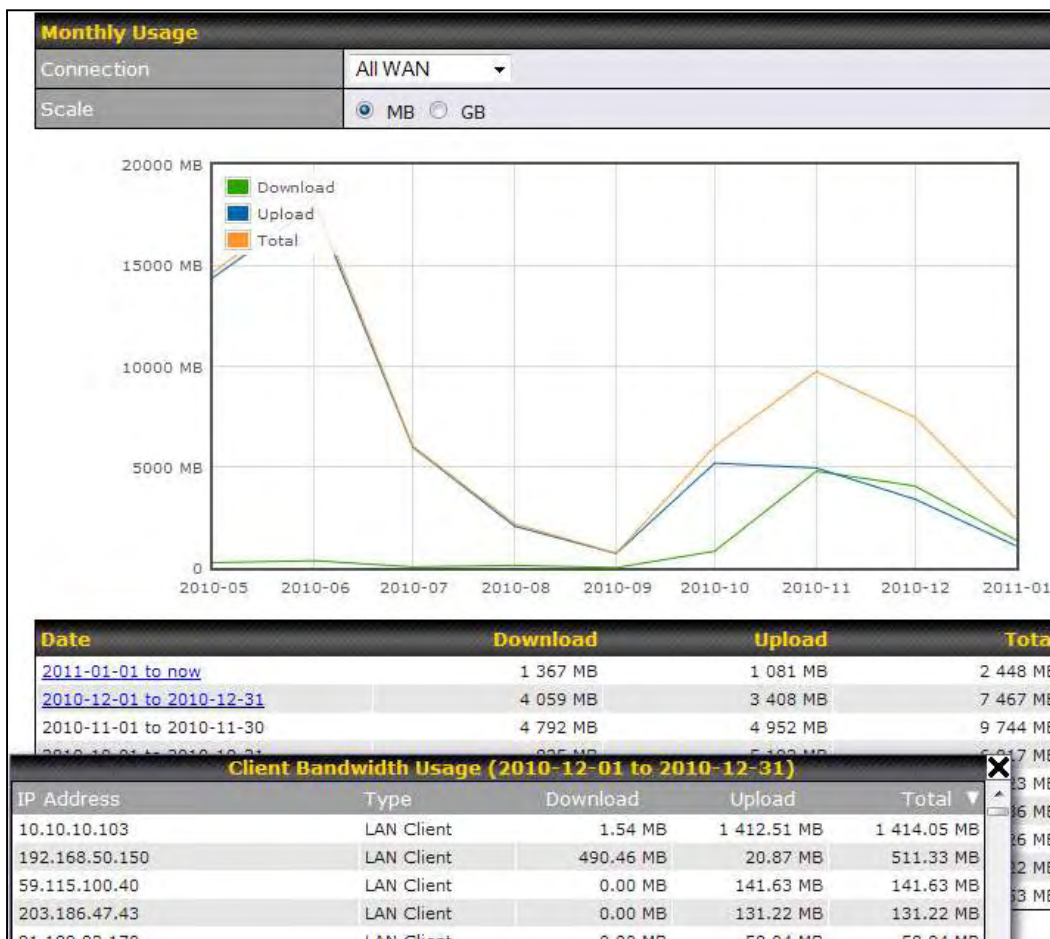

All WAN Monthly Bandwidth Usage

# Pepwave MAX and Surf User Manual

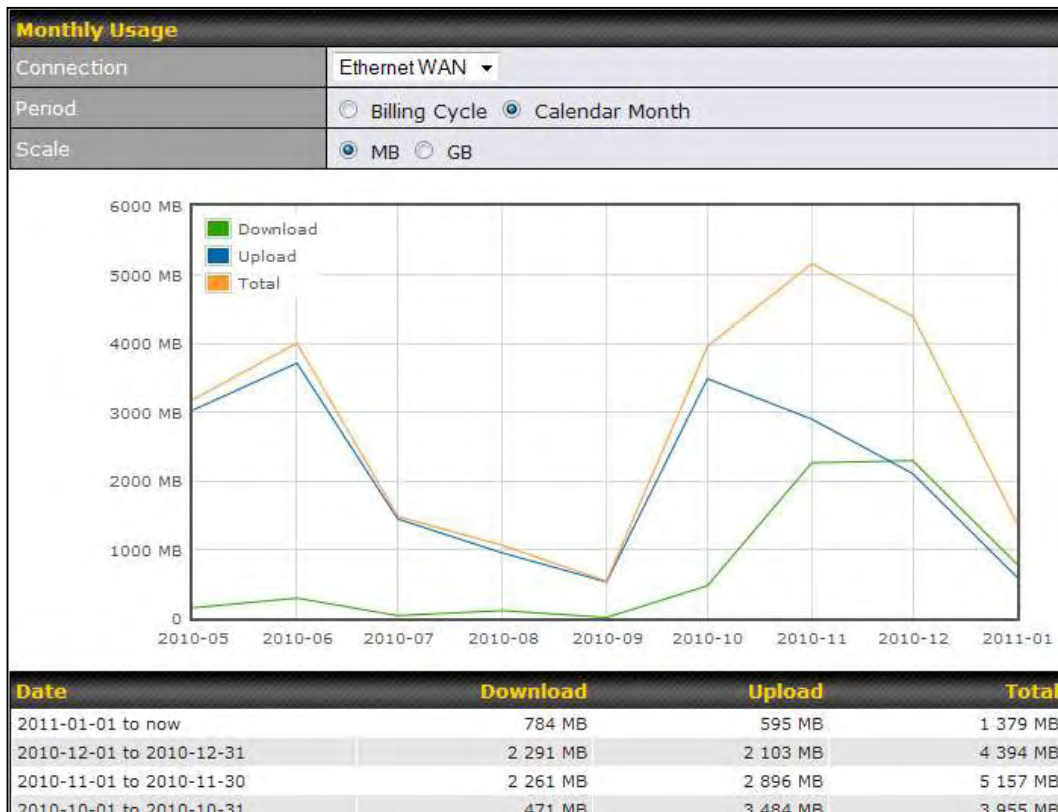

Ethernet WAN Monthly Bandwidth Usage

## Tip

By default, the scale of data size is in **MB**. 1GB equals 1024MB.

## Appendix A. Restoration of Factory Defaults

To restore the factory default settings on a Pepwave router, follow the steps below:

1. Locate the reset button on the front or back panel of the Pepwave router.
2. With a paper clip, press the reset button and hold it for at least 10 seconds, until the unit reboots itself.

After the Pepwave router finishes rebooting, the factory default settings will be restored.

### Important Note

All previous configurations and bandwidth usage data will be lost after restoring factory default settings. Regular backup of configuration settings is strongly recommended.

## Appendix B: Declaration

1. The device supports time division technology
2. Federal Communication Commission and Industry Canada Interference Statement

This equipment has been tested and found to comply with the limits for a Class A digital device, pursuant to part 15 of the FCC Rules. These limits are designed to provide reasonable protection against harmful interference when the equipment is operated in a commercial environment. This equipment generates, uses, and can radiate radio frequency energy and, if not installed and used in accordance with the instruction manual, may cause harmful interference to radio communications. Operation of this equipment in a residential area is likely to cause harmful interference in which case the user will be required to correct the interference at his own expense.

Caution: Any changes or modifications not expressly approved by the party responsible for compliance could void the user's authority to operate this equipment.

This transmitter must not be co-located or operating in conjunction with any other antenna or transmitter.

Operations in the 5.15-5.25GHz band are restricted to indoor usage only.

### IMPORTANT NOTE

#### FCC Radiation Exposure Statement (for MAX BR1 MK2)

This equipment complies with FCC radiation exposure limits set forth for an uncontrolled environment. This equipment should be installed and operated with minimum distance 24cm between the radiator & your body.

This transmitter must not be co-located or operating in conjunction with any other antenna or transmitter.

The availability of some specific channels and/or operational frequency bands are country dependent and are firmware programmed at the factory to match the intended destination.

# Pepwave MAX and Surf User Manual

## FCC Radiation Exposure Statement (for MAX BR1 mini)

This equipment complies with FCC radiation exposure limits set forth for an uncontrolled environment. This equipment should be installed and operated with minimum distance 25cm between the radiator & your body.

This transmitter must not be co-located or operating in conjunction with any other antenna or transmitter.

The availability of some specific channels and/or operational frequency bands are country dependent and are firmware programmed at the factory to match the intended destination.

## FCC Radiation Exposure Statement (for MAX700/ HD2/ HD2 IP67/ BR1/ Surf SOHO)

This equipment complies with FCC radiation exposure limits set forth for an uncontrolled environment. This equipment should be installed and operated with minimum distance 20cm between the radiator & your body.

## FCC Radiation Exposure Statement (for MAX On-The-Go)

This equipment complies with FCC radiation exposure limits set forth for an uncontrolled environment.

1. 20cm minimum when the product is operated alone without co-transmitting with a plug-in 3G USB dongle device.
2. 65cm minimum when the product is operated with a plug-in 3G USB device which has maximum of 7W ERP output power.
3. For co-transmission scenario which is not covered above, please consult the RF technician or device supplier.

This transmitter must not be co-located or operating in conjunction with any other antenna or transmitter.

The availability of some specific channels and/or operational frequency bands are country dependent and are firmware programmed at the factory to match the intended destination.

# Pepwave MAX and Surf User Manual

## Industry Canada Statement (for MAX BR1 MK2)

This device complies with Industry Canada license-exempt RSS standard(s). Operation is subject to the following two conditions: (1) this device may not cause interference, and (2) this device must accept any interference, including interference that may cause undesired operation of the device.

*Le présent appareil est conforme aux CNR d'Industrie Canada applicables aux appareils radio exempts de licence. L'exploitation est autorisée aux deux conditions suivantes : (1) l'appareil ne doit pas produire de brouillage, et (2) l'utilisateur de l'appareil doit accepter tout brouillage radioélectrique subi, même si le brouillage est susceptible d'en compromettre le fonctionnement.*

To maintain compliance with the RF exposure guidelines, place the unit at least 30cm from nearby persons.

*Mise en garde\_ : Pour assurer la conformité aux directives relatives à l'exposition aux fréquences radio, le jouet doit être placé à au moins 30\_cm des personnes à proximité.*

## Industry Canada Statement (for MAX Hotspot/ Surf SOHO/ MAX HD2 / MAX BR1 mini)

This device complies with Industry Canada license-exempt RSS standard(s). Operation is subject to the following two conditions: (1) this device may not cause interference, and (2) this device must accept any interference, including interference that may cause undesired operation of the device.

*Le présent appareil est conforme aux CNR d'Industrie Canada applicables aux appareils radio exempts de licence. L'exploitation est autorisée aux deux conditions suivantes : (1) l'appareil ne doit pas produire de brouillage, et (2) l'utilisateur de l'appareil doit accepter tout brouillage radioélectrique subi, même si le brouillage est susceptible d'en compromettre le fonctionnement.*

To maintain compliance with the RF exposure guidelines, place the unit at least 20cm from nearby persons.

*Mise en garde\_ : Pour assurer la conformité aux directives relatives à l'exposition aux fréquences radio, le jouet doit être placé à au moins 20\_cm des personnes à proximité.*



# Pepwave MAX and Surf User Manual

## Caution :

(i) the device for operation in the band 5150-5250 MHz is only for indoor use to reduce the potential for harmful interference to co-channel mobile satellite systems;

(ii) the maximum antenna gain permitted for devices in the band 5725-5850 MHz shall be such that the equipment still complies with the e.i.r.p. limits specified for point-to-point and non-point-to-point operation as appropriate; and

(iii) Users should also be advised that high-power radars are allocated as primary users (i.e. priority users) of the bands 5650-5850 MHz and that these radars could cause interference and/or damage to LE-LAN devices.

# Pepwave MAX and Surf User Manual

## **Avertissement:**

(i) les dispositifs fonctionnant dans la bande 5150-5250 MHz sont réservés uniquement pour une utilisation à l'intérieur afin de réduire les risques de brouillage préjudiciable aux systèmes de satellites mobiles utilisant les mêmes canaux;

(ii) le gain maximal d'antenne permis (pour les dispositifs utilisant la bande de 5725 à 5 850 MHz) doit être conforme à la limite de la p.i.r.e. spécifiée pour l'exploitation point à point et l'exploitation non point à point, selon le cas;

(iii) De plus, les utilisateurs devraient aussi être avisés que les utilisateurs de radars de haute puissance sont désignés utilisateurs principaux (c.-à-d., qu'ils ont la priorité) pour les bandes 5650-5850 MHz et que ces radars pourraient causer du brouillage et/ou des dommages aux dispositifs LAN-EL.

## **Radiation Exposure Statement: (For MAX BR1 Mini)**

This equipment complies with ISED radiation exposure limits set forth for an uncontrolled environment. This equipment should be installed and operated with minimum distance 25cm between the radiator & your body.

## **Déclaration d'exposition aux radiations:**

Cet équipement est conforme aux limites d'exposition aux rayonnements ISED établies pour un environnement non contrôlé. Cet équipement doit être installé et utilisé avec un minimum de 25 cm de distance entre la source de rayonnement et votre corps.

### **3. CE Statement for Pepwave Routers**

Europe – EU Declaration of Conformity

This device complies with the essential requirements of the R&TTE Directive 1999/5/EC. The following test methods have been applied in order to prove presumption of conformity with the essential requirements of the R&TTE Directive 1999/5/EC:

- EN 60950-1: 2006 + A11 : 2009+A1 : 2010+ A12: 2011  
Safety of Information Technology Equipment
- EN50385 : 2002 / Article 3(1)(a)  
Product standard to demonstrate the compliance of radio base stations and fixed terminal stations for wireless telecommunication systems with the basic restrictions or the reference levels related to human exposure to radio frequency electromagnetic fields (110MHz - 40 GHz) - General public

# Pepwave MAX and Surf User Manual

EN 300 328 V1.7.1: 2006

Electromagnetic compatibility and Radio spectrum Matters (ERM); Wideband Transmission systems; Data transmission equipment operating in the 2,4 GHz ISM band and using spread spectrum modulation techniques; Harmonized EN covering essential requirements under article 3.2 of the R&TTE Directive

- EN 301 908-1 V5.2.1: 2011

Electromagnetic compatibility and Radio spectrum Matters (ERM); Base Stations (BS), Repeaters and User Equipment (UE) for IMT-2000 Third-Generation cellular networks; Part 1: Harmonized EN for IMT-2000, introduction and common requirements, covering essential requirements of article 3.2 of the R&TTE Directive

- EN 301 511 V9.0.2: 2003

Global System for Mobile communications (GSM); Harmonized standard for mobile stations in the GSM 900 and DCS 1800 bands covering essential requirements under article 3.2 of the R&TTE directive (1999/5/EC)

- EN 301 489-1 V1.9.2: 2008

Electromagnetic compatibility and Radio Spectrum Matters (ERM); ElectroMagnetic Compatibility (EMC) standard for radio equipment and services; Part 1: Common technical requirements

- EN 301 489-7 V1.3.1: 2005

ElectroMagnetic compatibility and Radio spectrum Matters (ERM); ElectroMagnetic Compatibility (EMC) standard for radio equipment ad services; Part 7: Specific conditions for mobile and portable radio and ancillary equipment of digital cellular radio telecommunications systems (GSM and DCS)

- EN 301 489-17 V2.2.1: 2012

Electromagnetic compatibility and Radio spectrum Matters (ERM); ElectroMagnetic Compatibility (EMC) standard for radio equipment and services; Part 17: Specific conditions for 2,4 GHz wideband transmission systems and 5 GHz high performance RLAN equipment

- EN 301 489-24 V1.5.1: 2010

Electromagnetic compatibility and Radio Spectrum Matters (ERM); ElectroMagnetic Compatibility (EMC) standard for radio equipment and services; Part 24: Specific conditions for IMT-2000 CDMA Direct Spread (UTRA) for Mobile and portable (UE) radio and ancillary equipment







CS Český  
[Czech]

[*Jméno výrobce*] tímto prohlašuje, že tento [*typ zařízení*] je ve shodě se základními požadavky a dalšími příslušnými ustanoveními směrnice 1999/5/ES.

# Pepwave MAX and Surf User Manual

 Dansk [Danish]	Undertegnede [ <i>fabrikantens navn</i> ] erklærer herved, at følgende udstyr [ <i>udstyrets typebetegnelse</i> ] overholder de væsentlige krav og øvrige relevante krav i direktiv 1999/5/EF.
 Deutsch [German]	Hiermit erklärt [ <i>Name des Herstellers</i> ], dass sich das Gerät [ <i>Gerätetyp</i> ] in Übereinstimmung mit den grundlegenden Anforderungen und den übrigen einschlägigen Bestimmungen der Richtlinie 1999/5/EG befindet.
 Eesti [Estonian]	Käesolevaga kinnitab [ <i>tootja nimi = name of manufacturer</i> ] seadme [ <i>seadme tüüp = type of equipment</i> ] vastavust direktiivi 1999/5/EÜ põhinõuetele ja nimetatud direktiivist tulenevatele teistele asjakohastele sätetele.
 English	Hereby, [ <i>name of manufacturer</i> ], declares that this [ <i>type of equipment</i> ] is in compliance with the essential requirements and other relevant provisions of Directive 1999/5/EC.
 Español [Spanish]	Por medio de la presente [ <i>nombre del fabricante</i> ] declara que el [ <i>clase de equipo</i> ] cumple con los requisitos esenciales y cualesquiera otras disposiciones aplicables o exigibles de la Directiva 1999/5/CE.
 Ελληνική [Greek]	ΜΕ ΤΗΝ ΠΑΡΟΥΣΑ [ <i>name of manufacturer</i> ] ΔΗΛΩΝΕΙ ΟΤΙ [ <i>type of equipment</i> ] ΣΥΜΜΟΡΦΩΝΕΤΑΙ ΠΡΟΣ ΤΙΣ ΟΥΣΙΩΔΕΙΣ ΑΠΑΙΤΗΣΕΙΣ ΚΑΙ ΤΙΣ ΛΟΙΠΕΣ ΣΧΕΤΙΚΕΣ ΔΙΑΤΑΞΕΙΣ ΤΗΣ ΟΔΗΓΙΑΣ 1999/5/ΕΚ.
 Français [French]	Par la présente [ <i>nom du fabricant</i> ] déclare que l'appareil [ <i>type d'appareil</i> ] est conforme aux exigences essentielles et aux autres dispositions pertinentes de la directive 1999/5/CE.
 Italiano [Italian]	Con la presente [ <i>nome del costruttore</i> ] dichiara che questo [ <i>tipo di apparecchio</i> ] è conforme ai requisiti essenziali ed alle altre disposizioni pertinenti stabilite dalla direttiva 1999/5/CE.
 Latviski [Latvian]	Ar šo [ <i>name of manufacturer / izgatavotāja nosaukums</i> ] deklarē, ka [ <i>type of equipment / iekārtas tips</i> ] atbilst Direktīvas 1999/5/EK būtiskajām prasībām un citiem ar to saistītajiem noteikumiem.
 Lietuvių [Lithuanian]	Šiuo [ <i>manufacturer name</i> ] deklaruoja, kad šis [ <i>equipment type</i> ] atitinka esminius reikalavimus ir kitas 1999/5/EB Direktyvos nuostatas.
 Nederlands [Dutch]	Hierbij verklaart [ <i>naam van de fabrikant</i> ] dat het toestel [ <i>type van toestel</i> ] in overeenstemming is met de essentiële eisen en de andere relevante bepalingen van richtlijn 1999/5/EG.
 Malti [Maltese]	Hawnhekk, [ <i>isem tal-manifattur</i> ], jiddikjara li dan [ <i>il-mudel tal-prodott</i> ] jikkonforma mal-ħtiġijiet essenzjali u ma provvedimenti oħrajn rilevanti li hemm fid-Dirrettiva 1999/5/EC.
 Magyar [Hungarian]	Alulírott, [ <i>gyártó neve</i> ] nyilatkozom, hogy a [ <i>... típus</i> ] megfelel a vonatkozó alapvető követelményeknek és az 1999/5/EC irányelv egyéb előírásainak.
 Polski [Polish]	Niniejszym [ <i>nazwa producenta</i> ] oświadczam, że [ <i>nazwa wyrobu</i> ] jest zgodny z zasadniczymi wymogami oraz pozostałymi stosownymi postanowieniami Dyrektywy 1999/5/EC.
 Português [Portuguese]	[ <i>Nome do fabricante</i> ] declara que este [ <i>tipo de equipamento</i> ] está conforme com os requisitos essenciais e outras disposições da Directiva 1999/5/CE.

# Pepwave MAX and Surf User Manual

 Slovensko [Slovenian]	<i>[Ime proizvajalca]</i> izjavlja, da je ta <i>[tip opreme]</i> v skladu z bistvenimi zahtevami in ostalimi relevantnimi določili direktive 1999/5/ES.
 Slovensky [Slovak]	<i>[Meno výrobcu]</i> týmto vyhlasuje, že <i>[typ zariadenia]</i> spĺňa základné požiadavky a všetky príslušné ustanovenia Smernice 1999/5/ES.
 Suomi [Finnish]	<i>[Valmistaja = manufacturer]</i> vakuuttaa täten että <i>[type of equipment = laitteen tyyppimerkintä]</i> tyyppinen laite on direktiivin 1999/5/EY oleellisten vaatimusten ja sitä koskevien direktiivin muiden ehtojen mukainen.
 Svenska [Swedish]	Härmed intygar <i>[företag]</i> att denna <i>[utrustningstyp]</i> står i överensstämmelse med de väsentliga egenskapskrav och övriga relevanta bestämmelser som framgår av direktiv 1999/5/EG.

## 4. NCC for Pepwave Routers

For MAX Transit , MAX BR1 MK2

WLAN

[警語]

「電磁波曝露量 MPE 標準值 1mW/cm<sup>2</sup> · 本產品使用時建議應距離人體 24 cm」

[警語內容]

(1) 電磁波警語標示：「減少電磁波影響，請妥適使用」。標示方式：必須標示於設備本體適當位置及設備外包裝及使用說明書上。

低功率電波輻射性電機管理辦法

第十二條 經型式認證合格之低功率射頻電機，非經許可，公司、商號或使用者均不得擅自變更頻率、加大功率或變更原設計之特性及功能。

第十四條 低功率射頻電機之使用不得影響飛航安全及干擾合法通信；經發現有干擾現象時，應立即停用，並改善至無干擾時方得繼續使用。前項合法通信，指依電信法規定作業之無線電通信。低功率射頻電機須忍受合法通信或工業、科學及醫療用電波輻射性電機設備之干擾。

本行動寬頻設備的行動寬頻頻段(LTE900/LTE1800)

警告使用者：

此為甲類資訊技術設備，於居住環境中使用時，可能會造成射頻擾動，在此種情況下，使用者會被要求採取某些適當的對策。

# Pepwave MAX and Surf User Manual

## **5. Compliance (For MAX BR1 mini & MAX BR1 & BR1 MK2)**

Please observe the following instructions:

### 5.1 Ex marking:

CLASS I, DIVISION 2, GROUP C AND D

### 5.2 Warning:

5.2.2 The Antenna shall not be disconnected while the power is connected.

5.2.3 The front panel presents an electrostatic hazard. Clean only by using a damp cloth.

5.3.3 Provision shall be made to prevent the rated voltage being exceeded by the transient disturbances of more than 140% of the peak rated voltage.

5.3.4 Explosion Hazard. Do not connect or disconnect when energized.

### 5.2 Mise en garde:

5.2.2 L'antenne ne doit pas être déconnectée quand le matériel est toujours sous tension

5.2.3 Le panneau avant présente un risque électrostatique. Utiliser un chiffon humide.

5.3.3 Des dispositions doivent être mises en place contre les perturbations passagères entraînant un dépassement de la tension assignée de plus de 140% du pic pouvant être atteint.

5.3.4 Risque d'explosion. Ne connectez ou ne déconnectez pas le produit quand celle-ci est sous tension.

---

### 5.3 Temperature class

Temperature class is T4A.

# PEP WAVE

Broadband Possibilities

[www.pepwave.com](http://www.pepwave.com)

## **Contact Us:**

### **Sales**

<http://www.pepwave.com/contact/sales/>

### **Support**

<http://www.pepwave.com/contact/>

### **Business Development and Partnerships**

<http://www.pepwave.com/partners/channel->