

**Read this
first...**

**Quick Install
Guide**

DI200 OfficeRight™ Inserting System

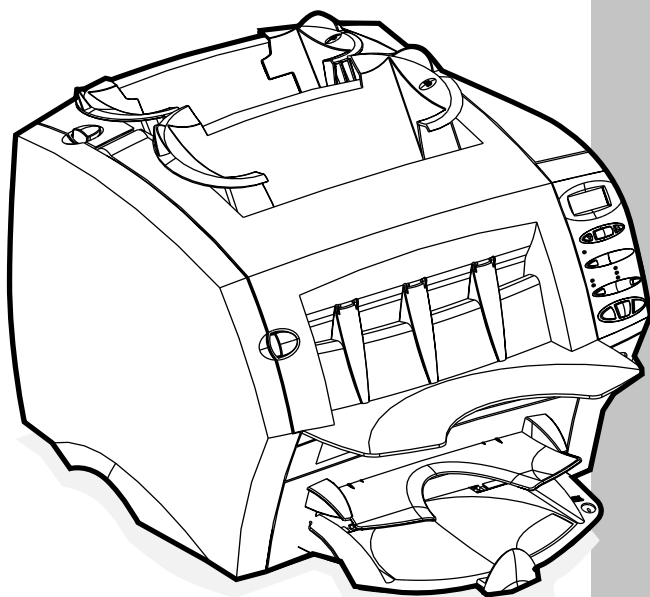

Welcome

Follow the steps in this booklet to install your DI200 OfficeRight™.

IMPORTANT: If you purchased the optional second sheet feeder, unpack and position it on the desktop **BEFORE** you follow these instructions.

 **Pitney Bowes**

step 1. Unpack

- a. Lift out the accessories and put them safely to one side

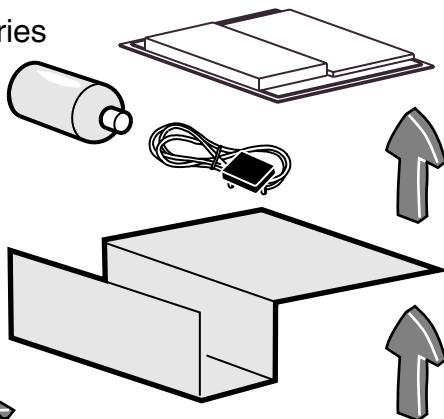

- b. Remove cardboard and foam packing

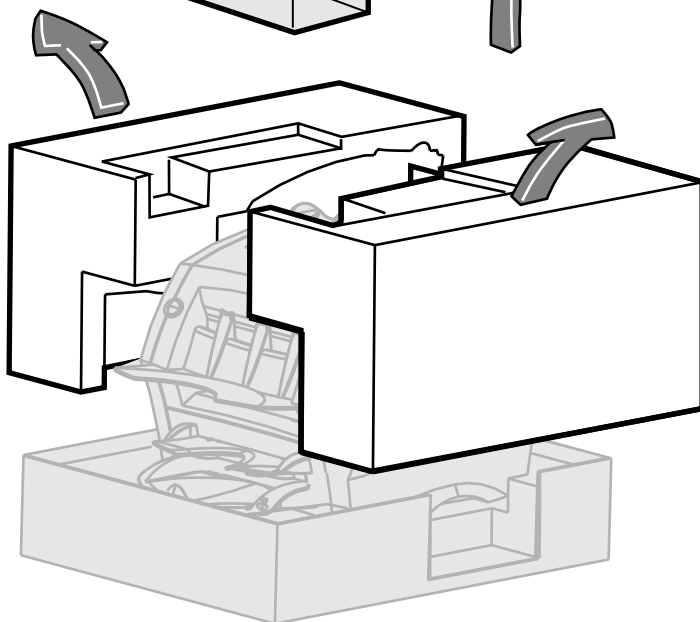

Check that you have the following accessories:

- Sample paper and envelopes (test material)
- Bottle of E-Z Seal®
- Power Cord

step 2. Locate

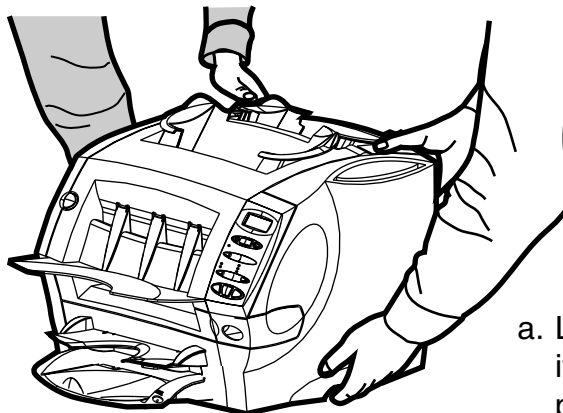

a. Lift the machine by its handles and place onto the desk. **See “SAFETY NOTICE!”** below

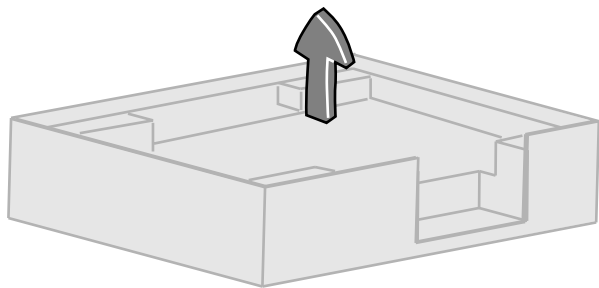

b. If you have the optional **2nd Sheet Feeder**, position the machine onto the feeder now

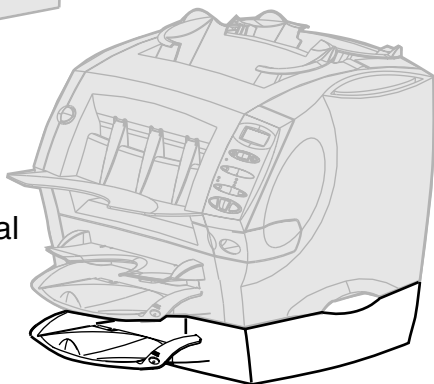

SAFETY NOTICE!

- Lift the machine only by its lifting handles.
- Lift correctly (bend knees and keep back straight).
- The machine weighs about 38 lb. (17.5kg)
We strongly recommend you get help to lift it.

step 3. Connect and turn on

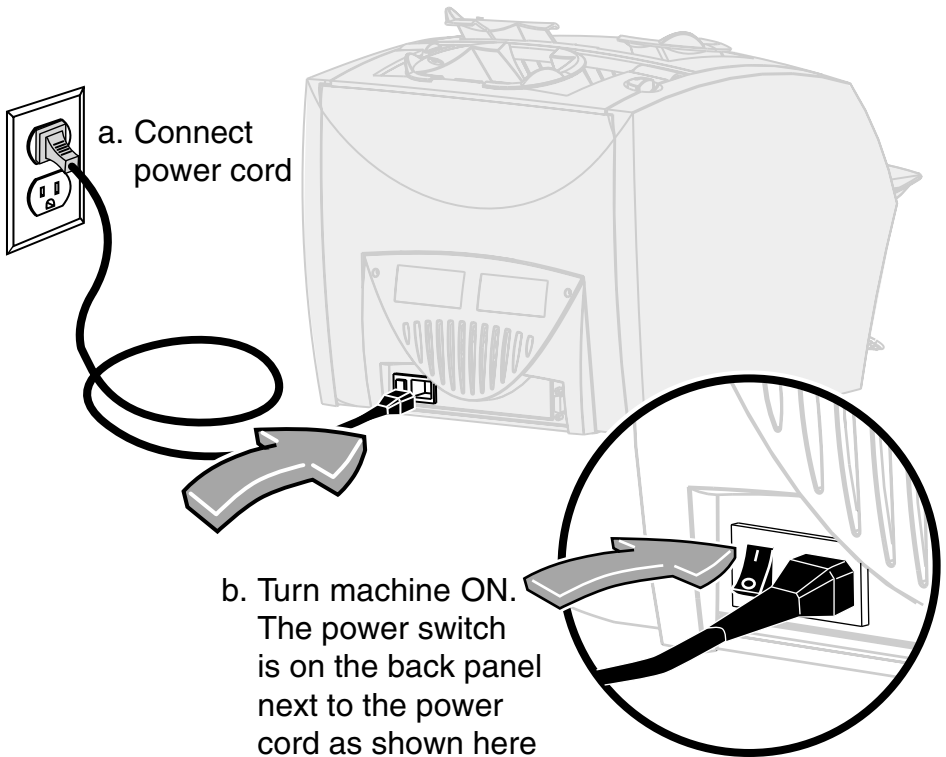

c. Display will show “**READY**” in a few seconds



SAFETY NOTICE!

- Locate the machine close to a power socket.
- Use the power cord supplied.
- See the *DI200 OfficeRight™ Operating Guide* for complete safety and connection information.

step 4. Fill moistener

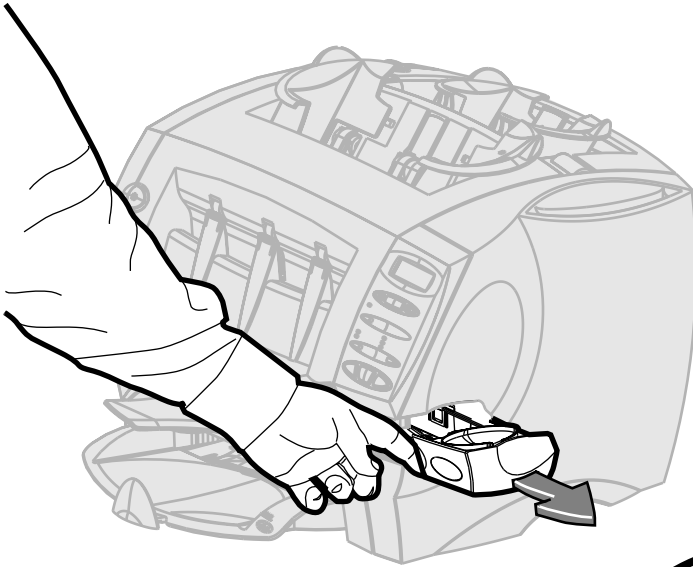

a. Slide moistener open

b. Fill with E-Z Seal®.
Use the entire
bottle supplied

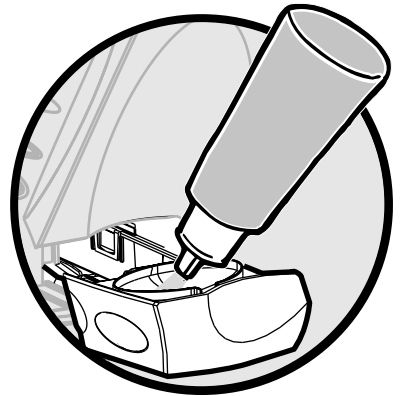

c. Slide moistener closed

The moistener takes about five minutes to become fully wet and ready for use.

Continue with the steps in this booklet in the meantime.

step 5 ■ Load envelopes

We've included test paper and envelopes so you can practice using the machine and check that it's working OK...

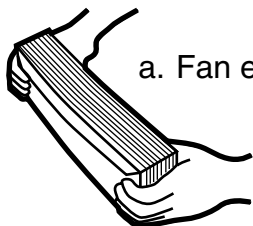

a. Fan envelopes and tap stack to align edges

b. Place envelopes in feeder **B**

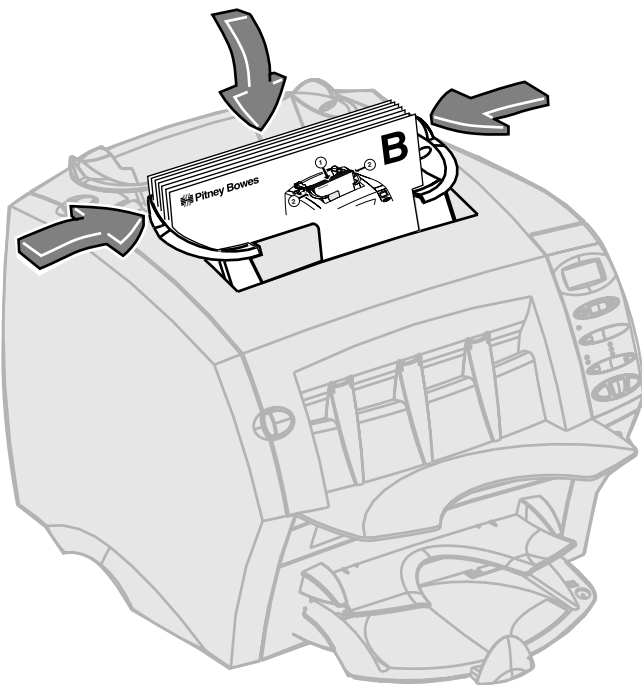

c. Slide side guides until they just touch envelopes. If guides are too tight, envelopes may stall; if they are too loose, envelopes may skew

Use test envelopes marked with the letter **B**.

IMPORTANT: Always fan (aerate) envelopes before loading. Load envelopes **RIGHT WAY UP** and **FACING YOU**.

Slide guides until they just touch envelopes, but do not restrict envelope feed. Use blue handles at rear of guides when moving them.

step 6 ■ Load sheets

a. Fan sheets and tap stack to align edges

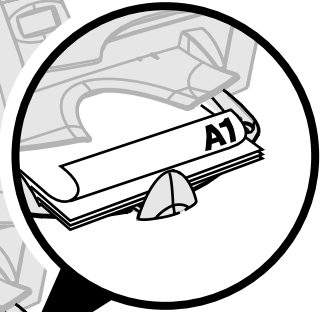
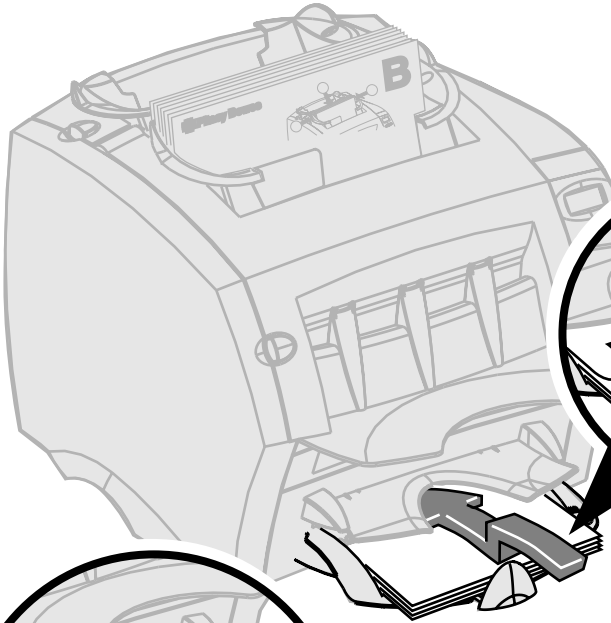
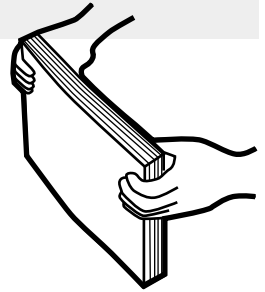

b. Place sheets in feeder **A1**,
FACE DOWN and
BOTTOM EDGE FIRST

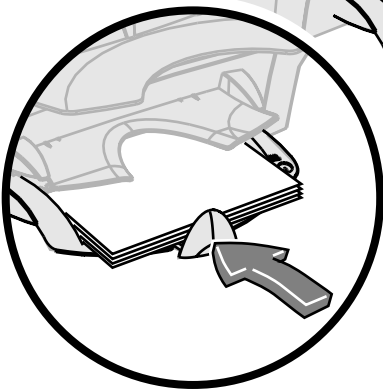

c. Push backstop in until it
just touches the stack
of sheets

Use test sheets marked with **A1**. Use Sheet Feeder **A1** for sheets that need folding.

IMPORTANT: Always fan (aerate) sheets before loading. Always load sheets **FACE DOWN** and **BOTTOM EDGE FIRST**.

step 7 ■ Setup

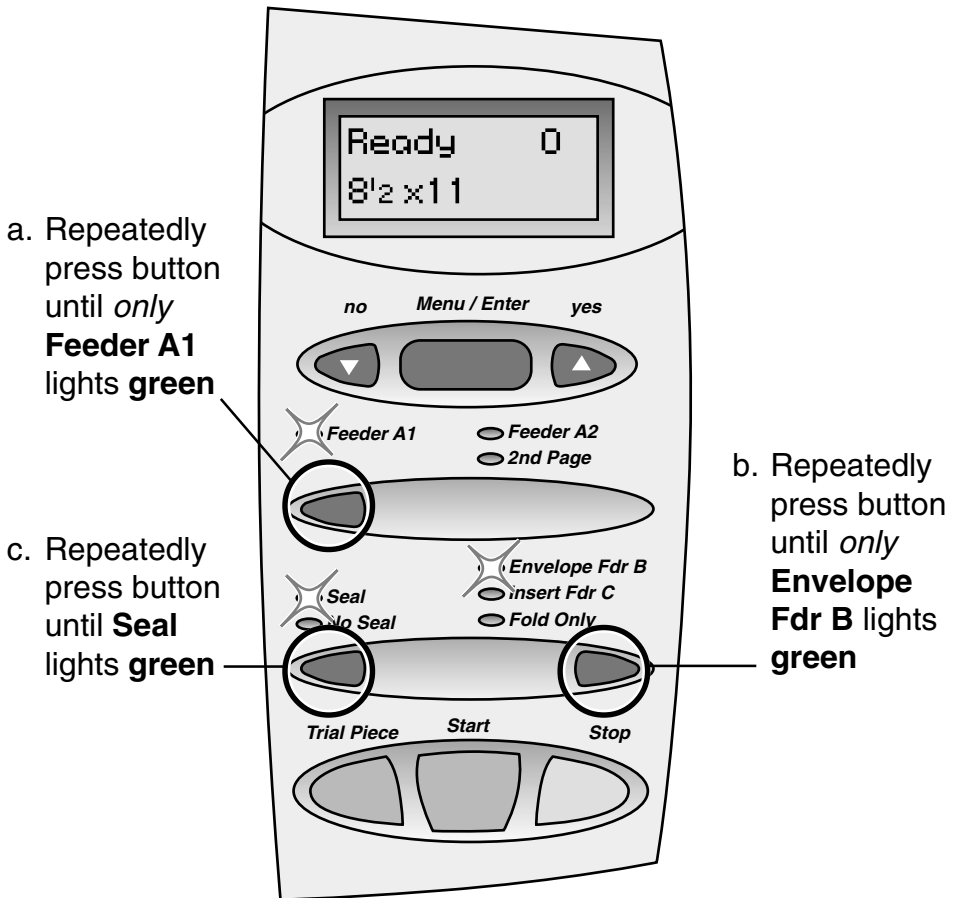

A **green** indicator shows that a feeder or function is selected.

Repeatedly pressing the selection buttons (a, b and c above) steps through the feeders and options available on your particular machine.

step 8 ■ Run test job

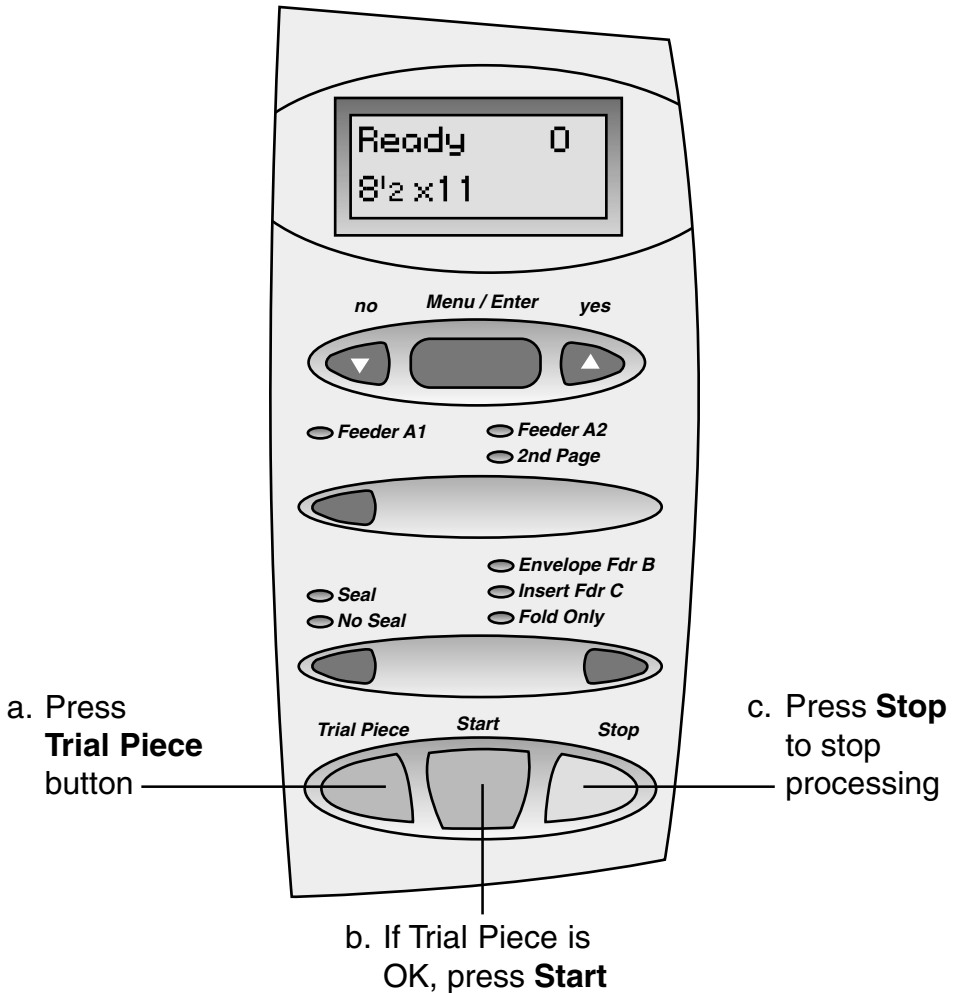

The trial piece will not be sealed so you can check the contents of the envelope. This is normal.

The counter will show the number of items processed.

step 9 ■ Congratulations!

Your DI200 OfficeRight™ is now ready to use

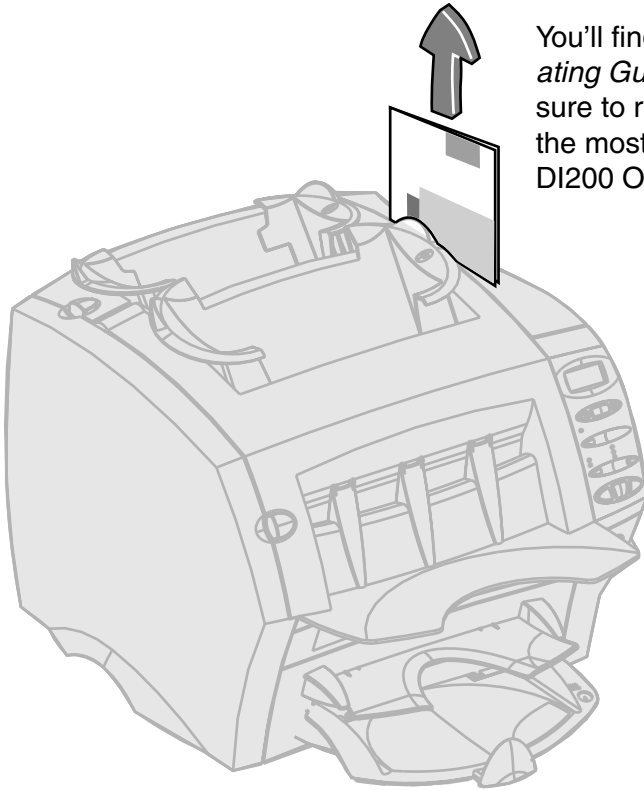

You'll find your *Operating Guide* here. Be sure to read it to get the most out of your DI200 OfficeRight™.

This Quick Install Guide allows you to unpack and test the machine in the shortest possible time.

The ***Operating Guide*** fully explains how to use your new system. It's located in a slot in the top right hand cover of the machine as shown above.

Problems?

Always Check Your *Operating Guide* First

If you experience any problems installing your equipment, please refer to the Troubleshooting section in the *Operating Guide* furnished with your machine.

Web Support

You'll find helpful answers to frequently asked questions at our web site. Please go to www.pitneybowes.com/support

Phone Support

If problems continue, technical assistance is readily available from the Pitney Bowes Customer Support Center. Before you call, please have the following information at hand:

- Product name: **DI200 OfficeRight™**
- Serial number: # _____ . This is located on the back cover of the machine.
- Nature of the problem: What happens and when does it happen? Did the machine display an error message? What was it?
- The steps you've already taken to solve the problem and the results.

Then call:

In the USA 1.800.253.6565

In Canada 1.800.672.6937

Supplies

Pitney Bowes has made it easier than ever to order supplies—such as E-Z Seal® (Item Code 601-0, USA only) and H200/H201 Moistener Wick Replacement (Item Code 639-0)—that are designed specifically for your DI200 OfficeRight™.

Order Online (USA Only)

Just point your browser to www.pitneybowes.com/supplies. You'll find a complete, easy-to-navigate online store that offers a wide assortment of genuine Pitney Bowes supplies at attractive prices.

Order by Phone

Our representatives will be happy to answer your questions and take your order.

 In the USA, call **1.800.243.7824**

 In Canada, call **1.800.672.6937**

Ask for a PB Supply Catalog (USA Only)

Call the number above or e-mail us at supplies@pb.com.



**One Elmcroft Road
Stamford, Connecticut 06926-0700
www.pitneybowes.com**

**Pitney Bowes Canada
2200 Yonge Street Suite 100
Toronto, Ontario M4S 3E1
1.800.672.6937**



*** S V 4 0 1 8 9 - Q S R E V A ***

**SV40189-QS Rev. A 9/02
© 2002 Pitney Bowes Inc.
Printed in England**