



Quick Start Guide
BOOMERANG

© Platform2 International Limited. All Rights Reserved.
Boomerang_QSG_V1.0



Quick Start Guide

www.pform2.com

Bluetooth Speaker

BOOMERANG

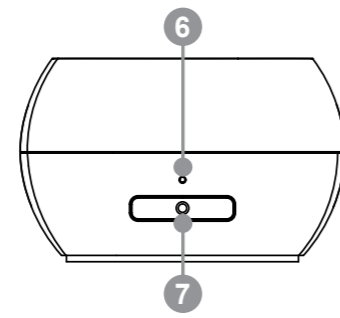
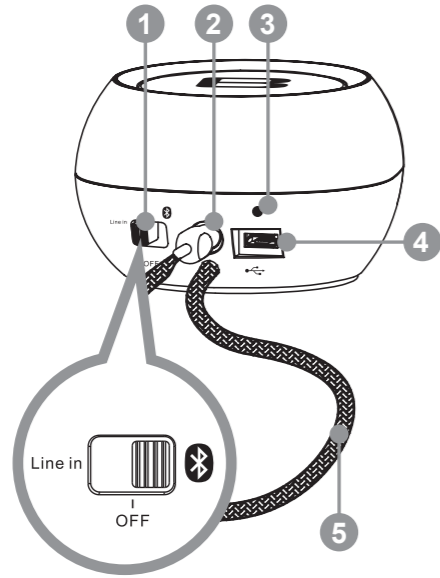

1	Line-in / Off / BT
2	Line-out Jack
3	Built-in microphone
4	Micro USB Jack (for Charging)
5	Line-in Cable
6	LED Indicator
7	Multi Function Button

How to use the Multi Function Button ("MFB") ...

1 Call up Siri

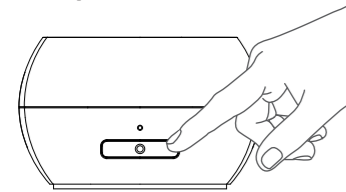

Press MFB to call up Siri

2 Answer incoming call

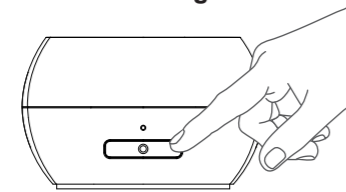

Press MFB to answer incoming call

3 Reject incoming call

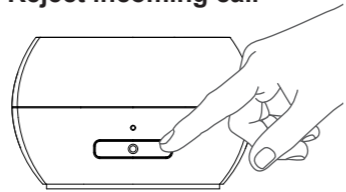

Press and hold MFB to reject incoming call

LED Indicator



Power OFF
→ LED OFF



Power OFF + Fully Charged
→ LED OFF



Charging (Power OFF)
→ Solid Red



Charging (Power ON / Line-in & BT)
→ Solid Purple



Pairing Mode (Power on / BT)
→ Flashing Blue



Power ON (Line-in & BT)
→ Solid Blue



Pairing Mode (Charging)
→ Flashing Purple & Red

How to Connect ...

1 Bluetooth mode (Pairing mode)

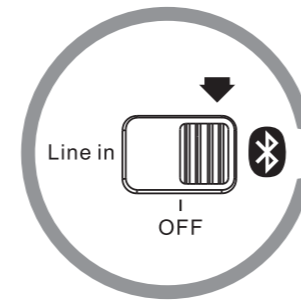

Slide to Bluetooth mode;
LED will light up

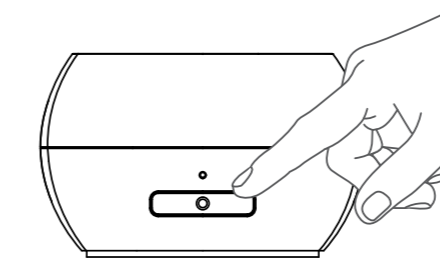
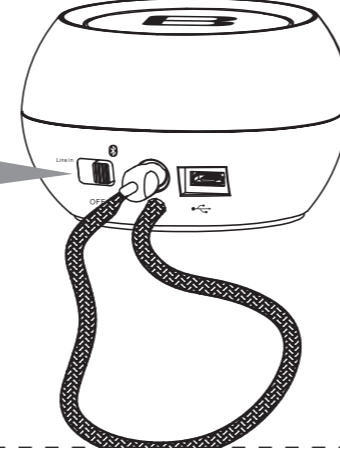

Press and hold "MFB" until it indicates flashing blue, search "Boomerang_mini" on your Bluetooth device and connect

2 Line-in mode

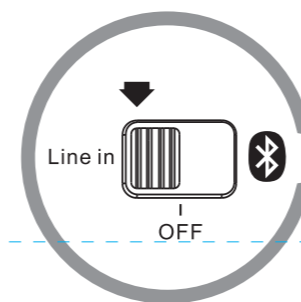

Slide to Line-in mode;
LED will light up

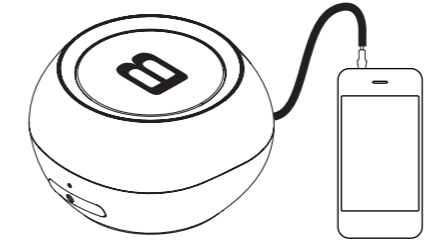
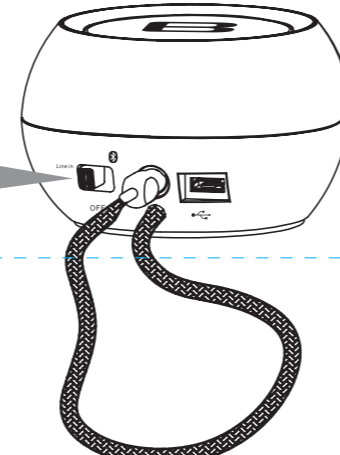

Plug the Built-in Cable to the device to stream music

3 Daisy chain connection

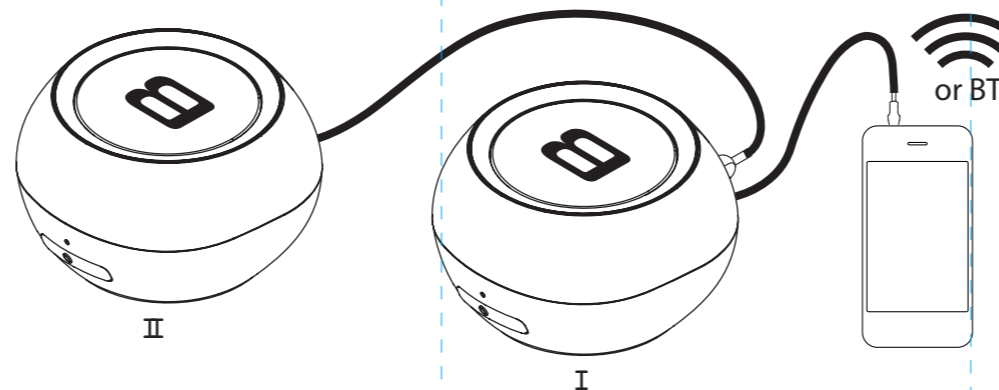

- Put the second speaker into the Line-in mode, and connect to the Line-out jack of first speaker

- Play music from your Music device via BT or Line-in on the first speaker; both speakers stream music at the same time

* When battery is empty, please charge the speaker for at least half an hour before switching on again.
* Fully charged once a month.
* Passcode is "0000".

Warning: Changes or modifications to this unit not expressly approved by the party responsible for compliance could void the user's authority to operate the equipment.

NOTE: This equipment has been tested and found to comply with the limits for a Class B digital device, pursuant to Part 15 of the FCC Rules. These limits are designed to provide reasonable protection against harmful interference in a residential installation. This equipment generates, uses and can radiate radio frequency energy and, if not installed and used in accordance with the instructions, may cause harmful interference to radio communications.

However, there is no guarantee that interference will not occur in a particular installation. If this equipment does cause harmful interference to radio or television reception, which can be determined by turning the equipment off and on, the user is encouraged to try to correct the interference by one or more of the following measures:

Reorient or relocate the receiving antenna.

Increase the separation between the equipment and receiver.

Connect the equipment into an outlet on a circuit different from that to which the receiver is connected.

Consult the dealer or an experienced radio/TV technician for help.

This device complies with Part 15 of the FCC Rules. Operation is subject to the following two conditions : (1) this device may not cause harmful interference, and (2) this device must accept any interference received, including interference that may cause undesired operation.

Shielded cables must be used with this unit to ensure compliance with the Class B FCC limits.