

OWNER'S MANUAL



 **Polaris280**

IMPORTANT INFORMATION

SERIAL NUMBER

Important Information

- Always disconnect the Polaris from the pool wall when cleaning or backwashing the pool filter.
- After cleaning or backwashing, let the filtration system run for at least five minutes before re-connecting the Polaris.
- New plumbing lines should be flushed out before installing the Polaris.
- The Polaris should not be used to remove plaster dust in new pools.
- Always remove the Polaris **before swimmers enter the pool**.
- Except when checking the wheel RPM, do not handle the Polaris while it is operating.
- Always remove the Polaris from the pool before chemical shock treatments.

For customer service or support:

- Please mail Warranty Card immediately.
- For on-line support: www.polarispool.com
- To contact Polaris:

US and Canada

Customer Service
2620 Commerce Way
Vista, CA 92081-8438
1-800-822-7933

Australia

Unit 4, 19-21 Gibbes Street,
Chatswood, NSW 2067
1-300-POLARIS
ACN 080 168 092

Europe

C/Osana s/n.
(Pol.End.El Ramassar),
98520 Les Franqueses del Vallés
Barcelona, Spain
+34 93 840 25 85

Polaris Vac-Sweep® 280 Limited Warranty

This one year limited warranty is extended to the original consumer purchaser of this Polaris Vac-Sweep 280 Automatic Pool Cleaner manufactured by Polaris Pool Systems, Inc., from date of manufacture of the unit as established by the serial number, or one year from date of purchase with proof of purchase, whichever is later. Polaris warrants this product, including all parts and components thereof, to be free of defects in material and workmanship. Normal replacement items such as bags, tires, sweep hoses or sweep hose scrubbers which have been worn out by use or improper installation are not covered by this warranty. The Polaris 280 frame is warranted for a period of five years.

This limited warranty does not apply if the failure is caused or contributed to by any of the following: improper handling, improper usage, improper storage, winter freezing, abuse, improper installation, removal of the UWF filter screen, unsuitable application of the unit, improper maintenance, lack of reasonable and necessary maintenance, damage in transit or during installation, or damage from repairs/alterations made or attempted by anyone other than Polaris or one of its Authorized Service Centers.

Authorization to return a unit or part to the plant of manufacture must be obtained from the Polaris Customer Service Department. Check with your dealer for the local procedure before exercising this warranty. If further directions or instructions should be required, contact the Customer Service Department at 1-800-VAC-SWEEP (USA and Canada only) or (760) 599-9600. Be sure to insure the shipment against loss or damage in transit.

This limited warranty is valid only in the United States of America, Canada and Australia, and it does not apply to Polaris Vac-Sweep 280 Automatic Swimming Pool Cleaners sold or installed in any other country. Polaris Vac-Sweep 280 Automatic Pool Cleaners sold in the United Kingdom are warranted for a period of two years from date of invoicing to the first user.

WARNING: USE OF POLARIS 280 IN A VINYL LINER POOL

Certain vinyl liner patterns are particularly susceptible to rapid surface wear or pattern removal caused by objects coming into contact with the vinyl surface, including pool brushes, pool toys, floats, fountains, chlorine dispensers, and automatic pool cleaners. Some vinyl liner patterns can be seriously scratched or abraded simply by rubbing the surface with a pool brush. Ink from the pattern can also rub off during the installation process or when it comes into contact with objects in the pool. Polaris is not responsible for, and the Limited Warranty does not cover, pattern removal, abrasion or markings on vinyl liners.

U.S. Patents: 4,589,986; 4,618,420; 5,863,425; D409,341.

Foreign Patents: 732645; 2,260,903; 85149; 135,543; 2,072,463; 981274; 142,198; and other patents pending.

Unique product shape is a registered trademark.

Introduction

Congratulations on the purchase of your new automatic pool cleaner, and thank you for choosing Polaris. The Polaris Vac-Sweep 280 is designed to give you years of dependable and efficient service.

Like most mechanical devices, it will require periodic adjustments, routine maintenance, and the replacement of certain hardworking parts. Please have your cleaner checked occasionally by your local Polaris dealer or authorized service center.

Always insist on genuine Polaris replacement parts. Non-Polaris parts are not made to our specifications. They may have an adverse effect on the operation of your Polaris or may even damage it.

For best results, the Polaris 280 should be installed by a pool professional. For those with experience and confidence in handling plumbing and mechanical equipment, installation is outlined in this manual.

Polaris 280 Complete Cleaner

- | | |
|------------------------|--|
| 1. All Purpose Bag | 7. Hose Floats |
| 2. Head Float | 8. Back-up Valve |
| 3. Sweep Hose | 9. Quick Disconnect with
Universal Wall Fitting (UWF) |
| 4. Sweep Hose Scrubber | 10. Restrictor Discs (one red and one blue) |
| 5. Cleaner Body | |
| 6. Feed Hose | |

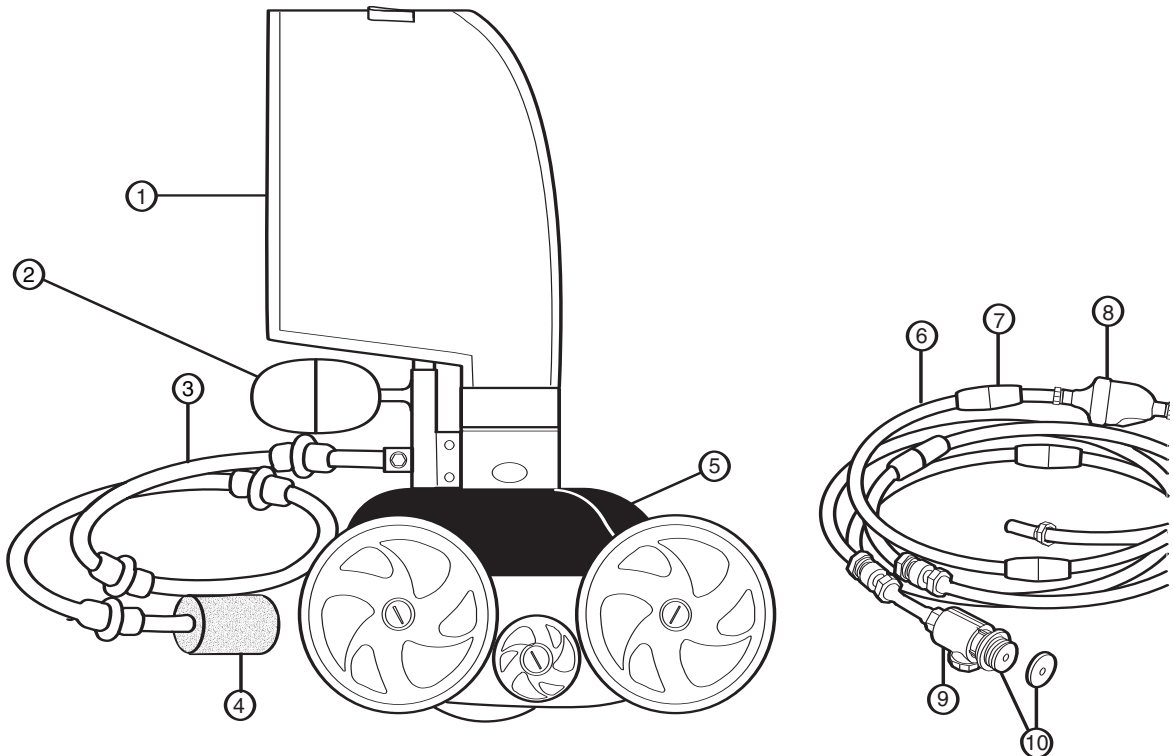

Quick Installation Instructions

Four quick steps to install and get maximum performance from the Polaris 280:

- Install the Universal Wall Fitting (UWF) with Quick Disconnect
- Adjust feed hose to fit pool length
- Assemble the cleaner
- Check for proper wheel RPM (revolutions per minute)

1

Install the Universal Wall Fitting

Installs in minutes on pools with a dedicated cleaner return line and a threaded 1-1/2" female pipe fitting.

1. Turn on the filtration pump and flush out the plumbing line. Turn pump off.
2. Remove the UWF from the Quick Disconnect and screw the UWF with the blue restrictor disc into the return opening.
3. Turn the Quick Disconnect clockwise into the UWF and pull away to secure.

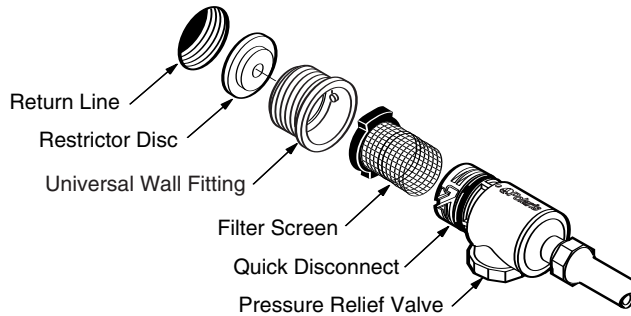

2

Adjust Feed Hose To Fit Pool Length

Measure the deepest part of the pool. Cut leader hose, from end that attaches to feed hose, so length is equal to the greatest depth of the pool.

Attach leader hose to feed hose and connect hose to the pool wall at the return line. Extend hose to farthest point of pool. The hose end must be within 6" – longer or shorter – of the farthest point. See dotted circle.

Hose too long? Separate hose at center swivel. Cut equal amounts of the overage from each 10-foot feed hose section.

Hose too short? Buy an additional feed hose section (part #9-100-3104), one swivel (part #D20) and two hose nuts (part #D15) from an authorized Polaris dealer.

After adjusting hose, position hose floats as shown.

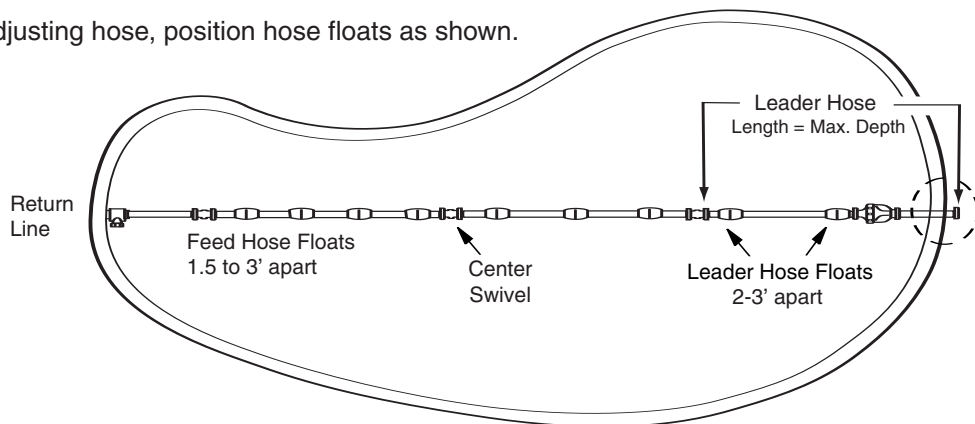

3

Assemble the Cleaner

1. Use the nut to attach the feed hose to the feed pipe.
2. Pull out the bag and attach the bag collar to the feed hose.
3. Position the head float 1/2 to 1 inch back from feed pipe.
4. Turn on the pool filtration pump and allow it to prime before turning on the booster pump.

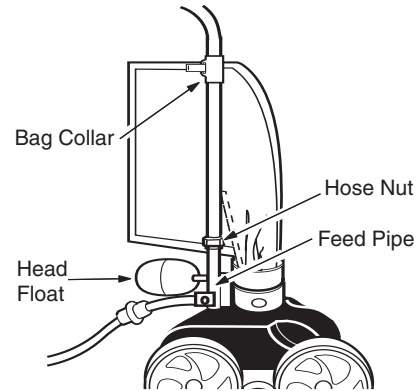

4

Check for Proper RPM

Before operating the Polaris, check for proper wheel revolutions per minute (RPM). For maximum efficiency, the Polaris should operate **between 28 and 32 RPM**.

1. Mark the single-wheel side tire.
2. Turn pump on, hold cleaner below water level and count wheel revolutions for 1 minute.
3. Optimum speed should be **between 28 and 32 RPM**.

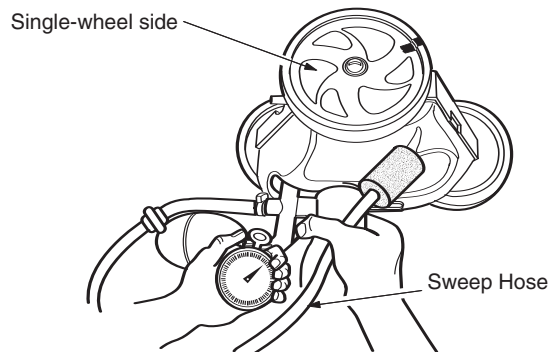

If count is **less than 28 RPM**:

- Check the filter screen in the Quick Disconnect for debris that restricts water flow.
- Clean the skimmer, filter and pump basket, clearing debris that restricts water flow.
- Check the hoses, connections and swivels for leaks that cause loss of water pressure.
- Remove the blue restrictor disc from the UWF.
- If an adjustable gate valve is installed on the booster pump or cleaner line, open it completely so water can flow freely to the Polaris.

If count is **more than 32 RPM**:

- Unscrew the pressure relief valve until the proper RPM is reached.
- If an adjustable gate valve is installed, adjust it to reduce the water flow to the cleaner.
- Replace the blue restrictor disc in the UWF with the red restrictor.

Fine Tuning The Polaris Cleaner

When operating correctly, the Polaris 280 vacuums, sweeps and scrubs all surfaces randomly throughout the pool. The climbing ability of the Polaris depends on the pool's shape and water pressure or flow. The Polaris climbs best in pools without sharp angles or curves in the transition from the pool floor to the pool wall.

Approximately every 3 minutes the Polaris 280 goes into back-up mode. This action pulls the Polaris away from pool obstacles and increases its random pattern.

Thrust Jet Adjustment

The thrust jet powers the direction of the Polaris. Factory position is straight back, but depending on the pool, other settings are helpful.

Sweep Hose Adjustment

The sweep hose should move in a gentle sweeping motion. To increase or decrease its motion, turn off the booster pump and turn the sweep hose adjustment screw.

See Troubleshooting for other action adjustments.

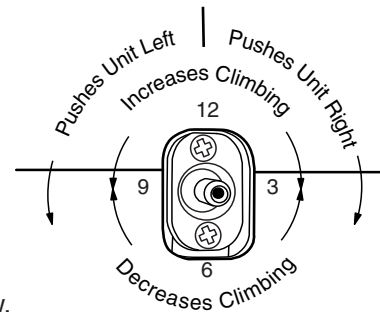

Routine Maintenance

Cleaning the Filter Bag

Remove the bag collar from the feed hose and depress the prongs to release the bag from the cleaner. Open the bag closure and dump out the debris.

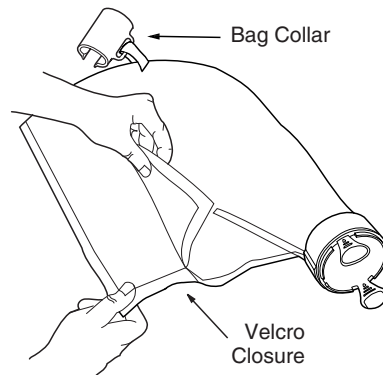

- ➔ Whenever possible, empty the filter bag when it is half full, especially if the dirt load is sand.
- ➔ It is easier to empty the filter bag when it is dry. Alternate between two filter bags. When one becomes full, remove it and put on the clean bag.

Backwashing the Pool Filter

Always disconnect the Polaris from the pool wall before cleaning or backwashing the pool filter. After cleaning or backwashing, let the filtration system run for at least five minutes to flush out the return lines before reconnecting the Polaris.

Storage and Winterizing

Never store the Polaris in direct sunlight. When storing for the winter, drain out all the water (freeze damage is not covered under the warranty). Remove the UWF from the pool wall by attaching the Quick Disconnect and using pulling pressure to unscrew. In some cases, it may be necessary to use the UWF Removal Tool (part #10-102-00) available from an authorized Polaris dealer.

Polaris280

Exploded Parts Diagram

English

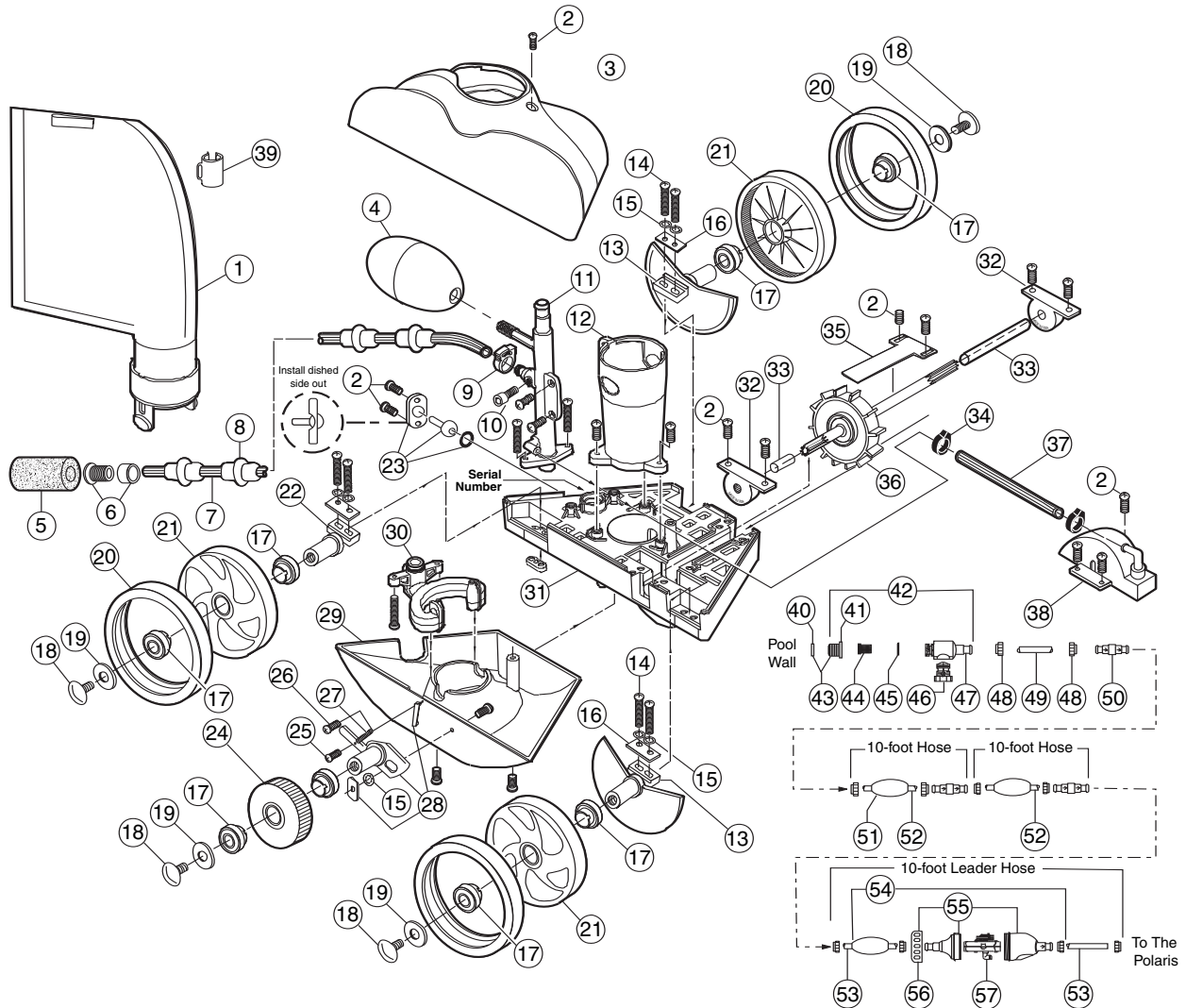

No.	Part #	Description	Qty	No.	Part #	Description	Qty	No.	Part #	Description	Qty
1	K16	All-Purpose Bag*	1	20	C10	Tire, MaxTrax**	3	39	9-100-1018	Bag Collar	1
2	C40	Screw, 10-32 x 3/8" SS Pan	20	21	C6	Wheel, Large (No Bearings Incl.)	3	40	10-112-00	Restrictor Disks, Red and Blue	1
3	K5	Top	1	22	C65	Axle, Large (Rear Wheel Only)	1	41	6-500-00	Universal Wall Fitting (UWF)	1
4	A20	Float, Head	1	23	C131	Thrust Jet Kit	1	42	9-100-9001	UWF Connector Assembly	1
5	9-100-3105	Sweep Hose Scrubber*	1	24	C16	Idler Wheel, Small	1	43	10-108-00	UWF Restrictor Kit	1
6	B25	Orifice Tip w/Orifice Tip Guard	1	25	C30	Screw, 4-40 x 3/16" SS Pan	1	44	6-504-00	Filter Screen, UWF/QD	1
7	B5	Sweep Hose Complete*	1	26	C32	Screw, 6-32 x 1/2" SS Pan Head	1	45	6-505-00	O-ring, UWF/QD	1
8	B10	Wear Rings*	8	27	C25	Spring for C36	1	46	9-100-9002	Pressure Relief Valve, Black	1
9	B15	Sweep Hose Attach Clamp	1	28	C36	Swing Axle Kit	1	47	D29	Quick Disconnect, UWF	1
10	B20	Adjust. Screw, Sweep Hose	1	29	K10	Base with Bracket	1	48	D15	Nut, Feed Hose	10
11	K30	Feed Pipe with Elbow	1	30	K25	Water Management System	1	49	**	Adapter Hose, 8-1/2"	1
12	K20	Vacuum Tube	1	31	K145	Frame	1	50	D20	Swivel, Ball Bearing	3
13	C66	Axle, Large (w/Sand/Gravel Grd)	2	32	C80	Ball Bearings, Turbine	2	51	D10	Float, Feed Hose	9
14	C76	Screw, 10-32 x 7/8" SS Pan	10	33	C83	Turbine Shaft Tubes	1	52	D45	Feed Hose, 10 Ft	2
15	C45	Lock Washer for C36	7	34	9-100-7170	Hose Clamp for WMS	2	53	D50	Feed Hose, Leader, 10 Ft	1
16	C70	Axle Plate for C65/C66	3	35	A40	Turbine Shaft Shield	1	54	G52	Back-up Valve Kit	1
17	C60	Ball Bearings, Wheels	8	36	C86	Drive Shaft Assembly	1	55	G54	Case Kit for G52	1
18	C55	Wheel Screw, Plastic	4	37	C120	Hose for C110, 7-1/2"	1	56	G57	Collar, Back-up Valve	1
19	C64	Wheel Washer, Plastic	4	38	C110	Turbine Cover with Elbow	1	57	G53	Mechanism for G52	1

*Wear items not covered by warranty.

Troubleshooting

If the Polaris cleaner displays the following actions, adjustments may be necessary to restore performance. Refer to exploded parts diagram for part numbers indicated in parentheses.

Action: Hangs up on steps or other obstacles for longer than 3 minutes.

- Solution:
1. Check the wheel RPM.
 2. Verify the back-up valve (54) is cycling.
 3. Adjust the thrust jet (#23).
 4. Remove unnecessary pool hardware or install a Ladder Guard Kit (order part #G21 from a Polaris dealer).

Action: Polaris is sluggish, running with less power than normal.

- Solution:
1. Check the filter screen (#44) in the Quick Disconnect (#47) and clean, if necessary.
 2. Clean the skimmer basket, pump basket, and pool filter.
 3. Check all of the hoses, connections, and swivels (#50) for leaks that could cause loss of water pressure.
 4. Check the wheel RPM.

Action: Polaris flies around the pool and/or does not make contact with the bottom.

- Solution:
1. Check the wheel RPM. If more than 32 RPM, unscrew the pressure relief valve (#46) to decrease water flow to cleaner.
 2. Confirm that the blue restrictor disc is installed in the UWF to decrease water flow. Or, install the red restrictor disc to decrease water flow even more.

3. Verify the back-up valve (#54) is cycling. Hold the valve out of the water and watch the jet. It should come on and go off.

Action: Polaris does not back up.

- Solution:
1. Verify the back-up valve (#54) is cycling.
 2. Check the wheel RPM.
 3. If the bag (#1) is full, empty it.
 4. If head float (#4) has water in it, replace it.
 5. Make sure feed hose is floating.

Action: Polaris only turns in one direction.

- Solution:
1. Adjust the thrust jet (#23).
 2. Make sure feed hose is floating.

Action: Feed hose becomes tangled.

- Solution:
1. Remeasure the hose to verify that it is adjusted to the proper length for the pool shape.
 2. With the Polaris operating, check that the swivels (#50) in the hose and the hose connections turn freely.
 3. Make sure feed hose is floating.
 4. With the Polaris turned off, spin each of the wheels. All wheels should turn together.

Action: Sweep hose is sucked into the vacuum tube.

- Solution:
1. Make sure the opening at the end of the sweep hose (#7) is not blocked by the sweep hose scrubber (#5).
 2. Adjust the sweep hose (#7) to a gentle sweeping motion.

Action: Sweep hose sprays too much water out of the pool.

- Solution:**
1. Adjust the speed of the sweep hose (#7) by tightening the adjustment screw (#10).
 2. Replace the sweep hose scrubber (#5) if it is worn or missing.
 3. Add a sweep hose weight (order part #B2) to keep the sweep hose from spraying.

Action: The cleaner does not clean the entire pool.

- Solution:**
1. Check the hose length reaches within 6" of the farthest point of the pool. If not, order a new hose section from your Polaris dealer.
 2. Check thrust jet for straight back position that optimizes random turning.
 3. While the cleaner is operating, hold it upside down and look into the vacuum tube. There should be two distinct, even jets of water. If there are not, contact Customer Service or a Polaris authorized Service Center for assistance.

Action: The cleaner is running in circles on its side.

- Solution:**
1. Check filter bag, if full it can weigh the cleaner down on one side.
 2. Remove the head float (#4) and shake it. If there is water in the float, order a new one.
 3. Check the hose floats to make sure they are spaced evenly.

Troubleshooting Worksheet

If these solutions do not result in improved performance, contact the Polaris dealer who sold you the cleaner or call Customer Service.

In order to provide faster and more convenient service, please have the following information available at the time of your call or when taking the Polaris in for service.

1. **Serial #:** _____
2. **Wheel RPM:** _____
3. **Is the back-up valve cycling?**
 Yes No
4. **Is the feed hose the proper length?**
 Yes No
5. **Are the swivels rotating freely?**
 Yes No
6. **How often do you clean the filter screen inside the Quick Disconnect?**
 Never Once a Week
 Twice a Week Once a Month
7. **Are the vacuum jets obstructed?**
 (While the cleaner is operating, hold it upside down and look into the vacuum tube. There should be two distinct, even jets of water.)
 Yes No
8. **Is the drive train functioning?**
 (As you spin each wheel independently, all the wheels should spin.)
 Yes No