

2005 Trail Boss Quadricycle

Owner's Manual
for Maintenance and Safety



POLARIS[®]
The Way Out.

Read this manual carefully. It contains important safety information.

This is an adult vehicle only.

Operation is prohibited for those under 16 years of age.

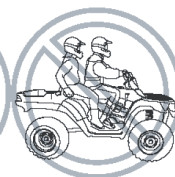
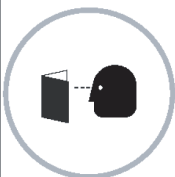

GB

Before you operate this vehicle, read the owner's manual.

D

Lesen Sie die Bedienungsanleitung bevor Sie dieses Fahrzeug fahren.

E

Antes de conducir este vehículo, lea el Manual del Propietario.

F

Lire le manuel du propriétaire avant d'utiliser ce véhicule.

I

Prima di usare il veicolo, leggete il manuale di istruzioni.

FI

Lue aina käyttöohjekirja ennen tämän ajoneuvon käyttöä.

P

Antes de utilizar este veículo, leia o manual do proprietário.

S

Innan du kör detta fordon, läs handboken.

© 2004

7173025



POLARIS
The Way Out.

For your nearest Polaris dealer,
call +1-800-POLARIS
or visit www.polarisindustries.com
Polaris Sales Inc.,
2100 Hwy. 55, Medina, MN 55340 U.S.A.
Phone +1-763-417-8650 Fax +1-763-542-0599
Part No. 9919822 Rev 01
Printed in U.S.A.



POLARIS

*For 50 years we've been
helping Polaris customers
find The Way Out.*

*It's been a fun ride.
But then, after all these years,
That's what we're all about.*

*Visit our Web site at
www.polarisindustries.com*



POLARIS[®]
The Way Out.

Copyright 2004 Polaris Sales Inc. All information contained within this publication is based on the latest product information at the time of publication. Due to constant improvements in the design and quality of production components, some minor discrepancies may result between the actual vehicle and the information presented in this publication. Depictions and/or procedures in this publication are intended for reference use only. Manufacturer accepts no liability for omissions or inaccuracies. Any reprinting or reuse of the depictions and/or procedures contained within, whether whole or in part, is expressly prohibited.

Printed in U.S.A.

2005 Trail Boss 330 Quadricycle Owner's Manual P/N 9919822

TABLE OF CONTENTS

VEHICLE IDENTIFICATION NUMBERS	5
SAFETY	6
FEATURES AND CONTROLS	40
OPERATION	55
EMISSION CONTROL SYSTEMS	60
MAINTENANCE AND LUBRICATION	61
POLARIS PRODUCTS	103
TROUBLESHOOTING	104
SPECIFICATIONS	108
WARRANTY	111
MAINTENANCE RECORD	113
INDEX	116

VEHICLE IDENTIFICATION NUMBERS

Record your vehicle's identification numbers and key number. Remove the spare key and store it in a safe place. Your key can be duplicated only by mating a Polaris key blank with one of your existing keys, so if both keys are lost, the ignition switch must be replaced.

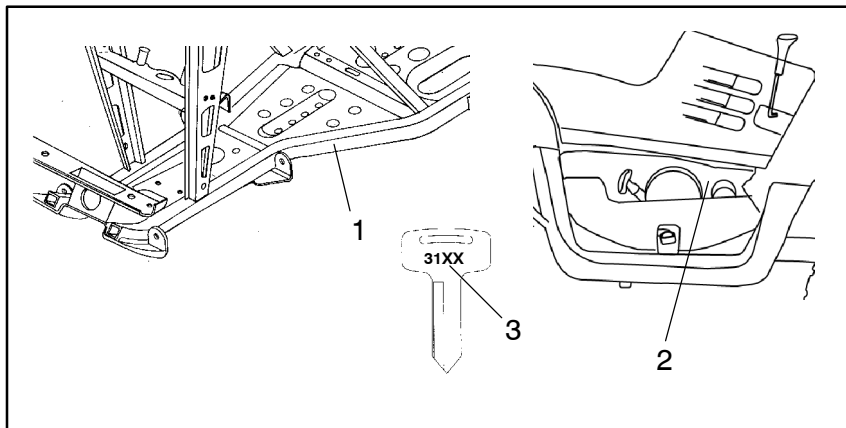

Vehicle Model Number: _____

Frame VIN (1): _____

Engine Serial Number (2): _____
(right front side of engine crankcase)

Key Number (3): _____

SAFETY

Operator Safety

The following signal words and symbols appear throughout this manual and on your vehicle. *Become familiar with their meanings before reading the manual.*



The *safety alert symbol*, on your vehicle or in this manual, alerts you to the potential for personal injury.



WARNING

The *safety alert warning* indicates a potential hazard that may result in serious injury or death.



CAUTION

The *safety alert caution* indicates a potential hazard that may result in minor personal injury or damage to the vehicle.

CAUTION

A *caution* indicates a situation that may result in damage to the vehicle.

NOTE:

A *note* will alert you to important information or instructions.

Operator Safety

WARNING

Failure to follow the warnings in this manual can result in serious injury or death.

A Polaris Quadricycle is not a toy and can be hazardous to operate. A collision or rollover can occur quickly, even during routine maneuvers, if you fail to take proper precautions.

Read and understand your owner's manual and all warnings before operating a Polaris Quadricycle.

Safety Training

When you purchased your new Quadricycle, your dealer offered a hands-on safety training course. You were also provided with printed materials that explain safe operating procedures. Review this information on a regular basis.

If you purchased a used Polaris Quadricycle from a party other than a Polaris dealer, please request free safety training from any authorized Polaris dealer.

Age Restriction

This vehicle is an **ADULT VEHICLE ONLY**. Operation is prohibited for anyone under 16 years of age.

SAFETY

Operator Safety

Know Your Vehicle and Riding Area

You are responsible for your personal safety, the safety of others and the protection of the environment. Read and understand your owner's manual. It includes important information about Quadricycle safety.

Ride responsibly. Know all laws and regulations concerning the operation of this vehicle in your area.

Restrictions

This vehicle is approved for OFF-ROAD TOWING ONLY. Operating a Quadricycle/trailer combination on public roads is prohibited.

Equipment Modifications

The warranty on your Polaris Quadricycle may be terminated if any equipment has been added, or if any modifications have been made, that increase speed or power.

NOTE: The addition of certain accessories, including (but not limited to) mowers, blades, tires, sprayers and large racks may change vehicle handling. Use only Polaris-approved accessories. Know their function and effect on the vehicle.

Operator Safety

WARNING

Serious injury or death can result if you do not follow the instructions and procedures listed here and throughout this manual.

-  Read and understand all warnings, cautions and operating procedures in this manual and on the safety labels before operating the Quadricycle.

Never operate a Quadricycle without proper instruction. *Take a training course.* Beginners should receive training from a certified instructor. Contact an authorized Polaris Quadricycle dealer or call Polaris at 1-800-342-3764.

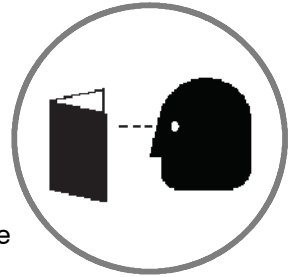

Never permit others to operate the Quadricycle unless they have read and understand this manual and all product labels, and have completed a certified safety training course.

-  Never allow anyone under 16 years of age to operate this vehicle.



-  Never carry a passenger. The purpose of the long seat is to allow the operator to shift position.

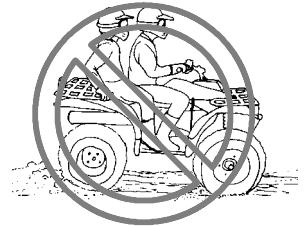

SAFETY

Operator Safety

- ⚠ Always wear an approved helmet that fits properly. Wear eye protection (goggles or face shield), gloves, boots, long sleeves and long pants.

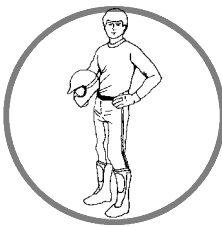

- ⚠ Never consume alcohol or drugs before or while operating a Quadricycle.



- ⚠ Never operate at excessive speeds. Travel and turn at speeds appropriate for the terrain, visibility, operating conditions and your experience.

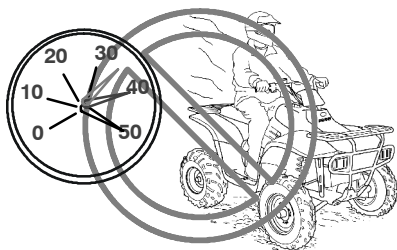

Operator Safety

- ⚠ Never attempt wheelies, jumps or other stunts.



- ⚠ Always inspect your Quadricycle before each use to verify that it's in safe operating condition. Follow the inspection and maintenance procedures outlined in this manual. See page 56.



- ⚠ Keep both hands on the handlebars. Keep your feet on the footrests.

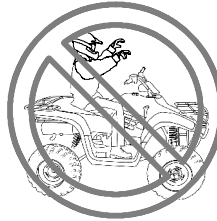

- ⚠ Always travel slowly when operating on unfamiliar terrain. Use extra caution.



SAFETY

Operator Safety

- ⚠ Use caution when operating on rough, slippery or loose terrain.



- ⚠ Always follow the procedures outlined in this manual for turning. See page 25.
Never turn sharply at excessive speeds, which can lead to vehicle overturn.



- ⚠ If a Quadricycle has been involved in an accident, always have an authorized Polaris dealer inspect the entire vehicle for possible damage, including (but not limited to) brake, throttle and steering systems.



Operator Safety

- ⚠ Never operate on hills too steep for the Quadricycle or for your abilities. Practice on smaller hills before attempting larger hills. Avoid climbing hills steeper than 25° .

Always follow the procedures outlined in this manual for climbing hills. See page 30.

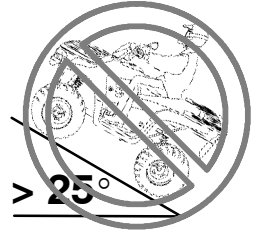

- ⚠ Always follow the procedures outlined in this manual for driving downhill and for braking on hills. See page 28.

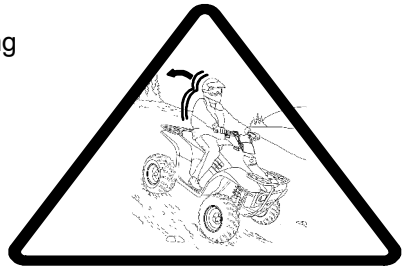

- ⚠ Always follow the procedures outlined in this manual for crossing the side of a hill. See page 29. Never attempt to turn the Quadricycle around on any hill until you've mastered (on level ground) the turning technique outlined in this manual.



SAFETY

Operator Safety

- ⚠ Always follow the procedures outlined in this manual for braking if you stall or roll backwards while climbing a hill. Never back down a hill. See page 31.



- ⚠ Always follow the procedures outlined in this manual for operating over obstacles. See page 27.



- ⚠ Always follow the procedures outlined in this manual for operating on slippery or loose surfaces. Use extra caution. Always avoid skidding or sliding. See page 26.



Operator Safety

- ⚠ Always follow the procedures outlined in this manual for driving through water. Never drive through deep or fast-flowing water. See page 34.

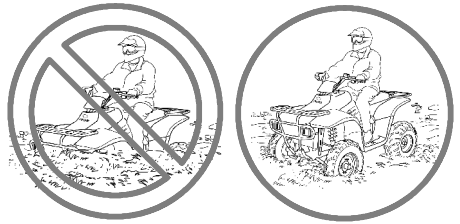

- ⚠ Always follow the procedures outlined in this manual for driving in reverse. See page 36.



- ⚠ Always use the size and type of tires specified for your Quadricycle. Maintain the proper tire pressure.

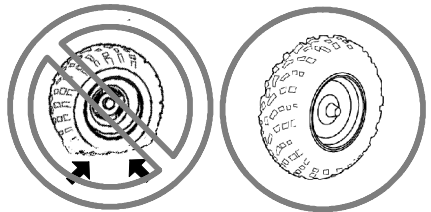

SAFETY

Operator Safety

- ⚠ Never modify a Quadricycle through improper installation or use of accessories.

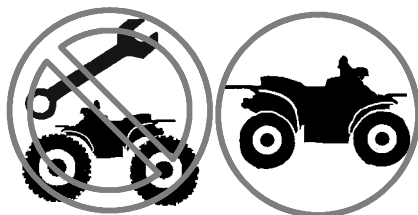

- ⚠ Never exceed the stated load capacity for your Quadricycle. Cargo must be properly distributed and securely attached. Reduce speed and follow the instructions in this manual for carrying cargo or towing. Allow a greater distance for braking.

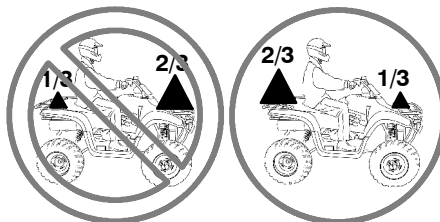

- ⚠ Never operate the Quadricycle on a frozen body of water.

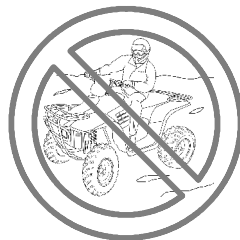

- ⚠ Operating on paved surfaces may seriously affect the handling and control of the Quadricycle and could result in loss of control, accident, and/or injury. Avoid sudden turns or swift movement of the handlebars.



Operator Safety

- ⚠ Always remove the ignition key when the vehicle is not in use to prevent unauthorized use or accidental starting.

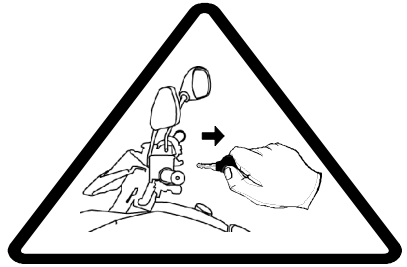

-
- ⚠ Always keep combustible materials away from the exhaust system. Exposure of combustibles to hot components could result in a fire.
-

**FOR MORE INFORMATION ABOUT QUADRICYCLE SAFETY,
call Polaris at 1-800-342-3764.**

SAFETY

Safety Decals and Locations

Warning decals have been placed on the vehicle for your protection. Read and follow the instructions on each decal carefully. If a decal becomes illegible or comes off, contact your Polaris dealer to purchase a replacement. Replacement *safety* decals are provided by Polaris at no charge. The part number is printed on the decal.

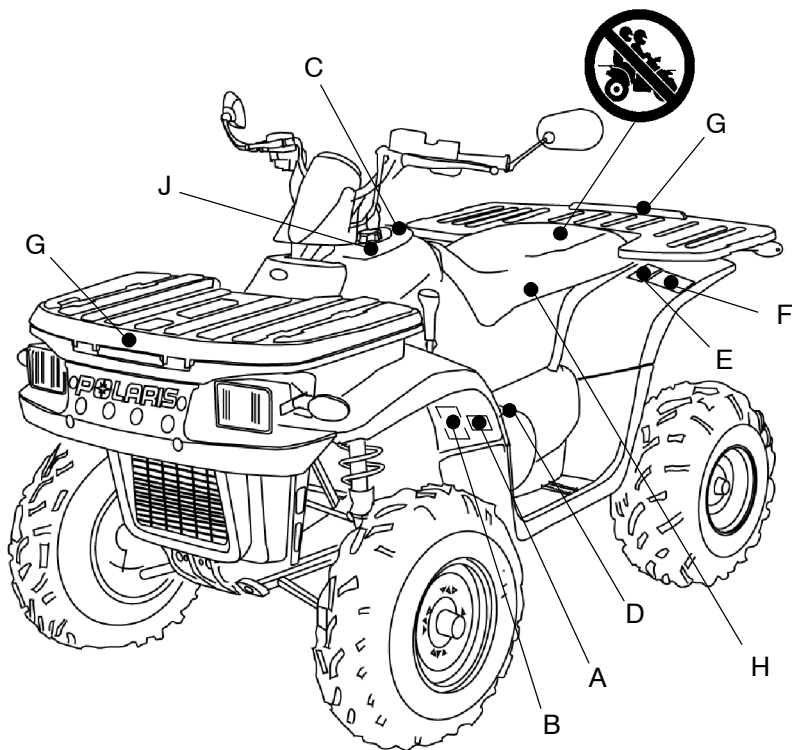

Decal Text

Never operate this vehicle on hills steeper than 25 degrees. To prevent flipover on hilly terrain, when going up or down, use throttle and brakes gradually.

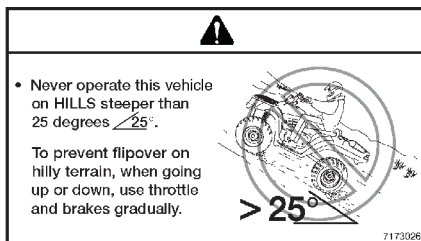





7173026

A

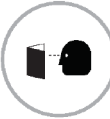
Safety Decals and Locations



GB Before you operate this vehicle, read the owner's manual.

D Lesen Sie die Bedienungsanleitung bevor Sie dieses Fahrzeug fahren.

E Antes de conducir este vehículo, lea el Manual del Propietario.

F Lire le manuel du propriétaire avant d'utiliser ce véhicule.

I Prima di usare il veicolo, leggete il manuale di istruzioni.

FI Lue aina käyttöohjekirja ennen tämän ajoneuvon käyttöä.

P Antes de utilizar este veículo, leia o manual do proprietário.

S Innan du kör detta fordon, läs handboken.

© 2004 7173025

B

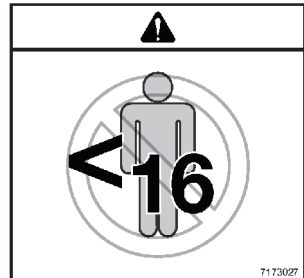

C

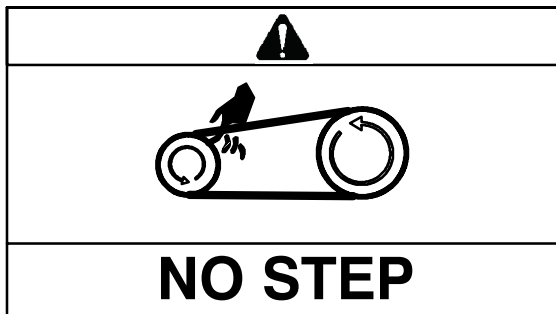

D

SAFETY

Safety Decals and Locations

Decal Text

NEVER ride as a passenger.

Passengers can cause a loss of control, resulting in SEVERE INJURY or DEATH.



E

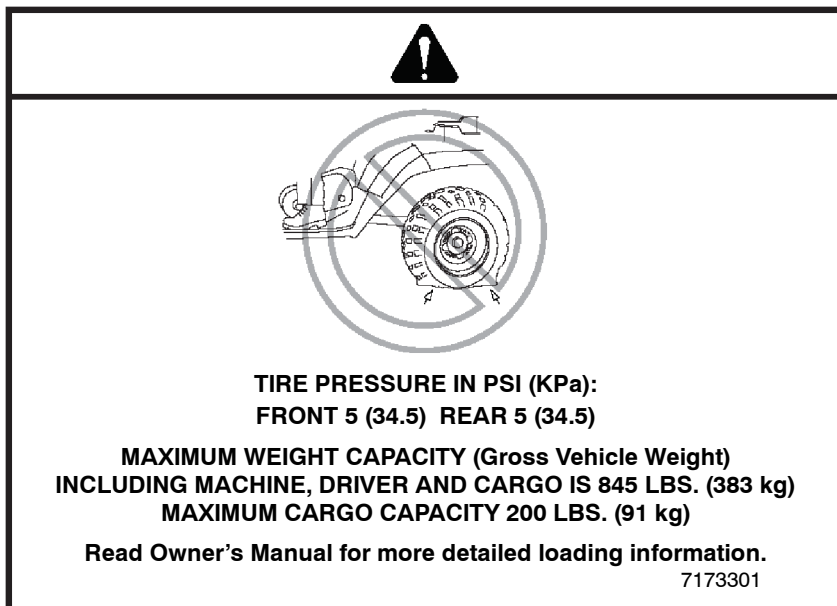

F

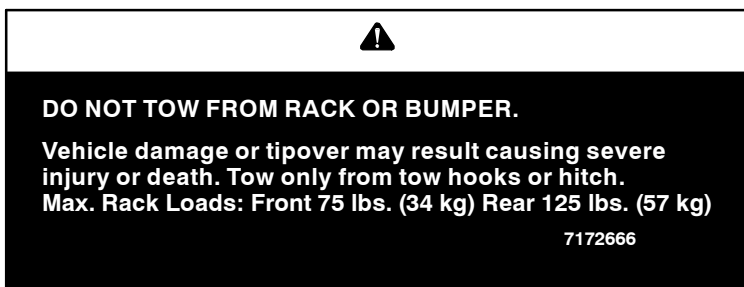

G

Safety Decals and Locations

<ul style="list-style-type: none">• Operation of this vehicle without the air filter element will severely damage the engine.• Clean pre-filter element often, more frequent cleaning required in dusty conditions. Do not operate vehicle without pre-filter.	<p style="text-align: center;"><u>ATTENTION</u></p> <ul style="list-style-type: none">• Specific carburetor jetting and adjustments are required depending on temperature and altitude. See your Owner's Manual. <p style="text-align: center;">Factory setting: 40° to 80° F. at 0-3000 feet (5° to 27° C. at 0-900 meters).</p> <p style="text-align: right;"><small>7170007</small></p>
---	---

H

Decal Text (H)

- Operation of this vehicle without the air filter element will severely damage the engine.
- Clean pre-filter element often, more frequent cleaning required in dusty conditions. Do not operate vehicle without pre-filter.
- Specific carburetor jetting and adjustments are required depending on temperature and altitude. See your Owner's Manual.

Factory setting:

40° to 80° F. at 0-3000 feet (5° to 27° C. at 0-900 meters).

<p style="text-align: center;"><u>VERRIDE</u> <u>SWITCH</u></p> <p>Reverse speed is limited.</p> <p>Reverse override is controlled by the override switch.</p> <p>See your Owner's Manual.</p> <p style="text-align: right;"><small>7079906</small></p>

J

SAFETY

Safety Decals and Locations

Hitch Decal

**TRAILER MAX WEIGHT:
850 LBS. (386 KG) ON LEVEL GROUND**

HITCH MAX. VERTICAL WEIGHT: 85 LBS. (39 KG)

7170915

Recoil Decal



**Recoil handle must be firmly
seated to prevent water entry.**

**Drain starter motor if water
enters. See owner's manual**

7172562

Safe Riding Gear

Always wear protective clothing to reduce the chance of injury.

1. Helmet

Always wear a helmet that meets or exceeds established safety standards. A helmet can prevent a severe head injury.

2. Eye Protection

Wear shatterproof goggles or a shatterproof helmet face shield. Use a lens anti-fogging product to keep them clean.

3. Gloves

Wear off-road style gloves with knuckle pads.

4. Boots

Wear strong over-the-calf boots with heels, like moto-cross boots.

5. Clothing

Wear long sleeves and long pants to protect arms and legs. Riding pants with kneepads and a jersey with shoulder pads provide the best protection. Do not wear loose clothing that can get entangled in the vehicle, tree branches or shrubs.

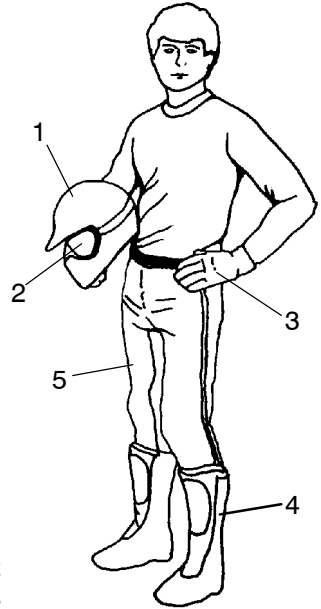

SAFETY

Driving Safely

Driving Procedures



1. Sit upright. Keep your feet on the footrests. Keep both hands on the handlebars.
2. Start the engine and allow it to warm up, then shift the transmission into gear.
3. Check your surroundings and determine your path of travel.
4. Release the parking brake.
5. Slowly squeeze the throttle lever toward the handlebar to begin driving. Squeeze the throttle lever further to increase speed.
6. Drive slowly. Practice maneuvering and using the throttle and brakes on level surfaces.

Driving Safely

Making Turns

1. To make a turn, steer in the direction of the turn, leaning your upper body to the inside of the turn while supporting your weight on the outer footrest. Use the same leaning technique for turning in reverse.
2. Practice turning at slow speeds before attempting to turn at faster speeds.



-
- ⚠** Never operate at excessive speeds. Travel and turn at speeds appropriate for the terrain, visibility, operating conditions and your experience.

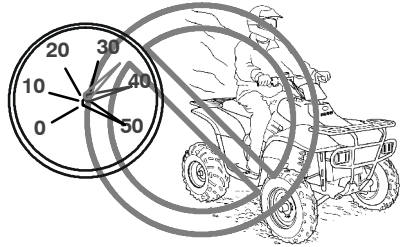

-
- ⚠** Always follow the procedures outlined in this manual for turning. Never turn sharply at excessive speeds, which can lead to vehicle overturn.



SAFETY

Driving Safely

Driving on Slippery Surfaces



Whenever driving on slippery or loose surfaces such as wet trails, gravel, snow or ice, follow these precautions:

1. Slow down before driving onto slippery surfaces.
2. Use extra caution.
3. Be alert. Watch the trail. Avoid quick, sharp turns.

NOTE: To correct a rear wheel skid, turn the handlebars in the same direction as the skid and shift body weight forward.

-
-  Always follow the procedures outlined in this manual for operating on slippery or loose surfaces. Use extra caution. Always avoid skidding or sliding.



Driving Safely

Driving Over Obstacles



1. Always check for obstacles before operating in a new area. Serious injury or death can result if your vehicle comes in contact with a hidden obstacle.
2. Be alert. Watch the terrain. Use extra caution.
3. Never operate over large obstacles.
4. Avoid hazards such as logs, rocks and low branches.

⚠ Always follow the procedures outlined in this manual for operating over obstacles.



SAFETY

Driving Safely

Driving Downhill

Whenever descending a hill, follow these precautions:

1. Check the terrain carefully.
2. Avoid hills with excessively slippery or loose surfaces.
3. Never go down a hill at high speed.
4. Slow down.
5. Avoid going down a hill at an angle, which can cause the vehicle to pitch sharply to one side.
6. Drive straight downhill.
7. Shift your weight rearward.
8. Apply the foot brake *slightly* to aid in slowing.
9. Know how to use the hand brake.



-
- ⚠** Always follow the procedures outlined in this manual for driving downhill and for braking on hills.



-
- ⚠** Never operate at excessive speeds. Travel and turn at speeds appropriate for the terrain, visibility, operating conditions and your experience.

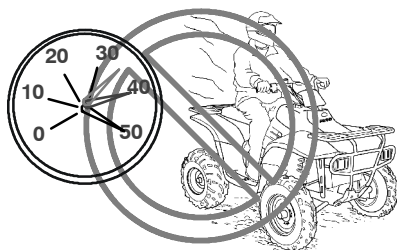

Driving Safely Sidehilling



Avoid crossing the side of a hill (sidehilling) if possible. If sidehilling is necessary, follow these precautions:

1. Slow down.
2. Avoid hills with excessively slippery or loose surfaces.
3. Shift your weight uphill.
4. Avoid crossing the sides of steep hills.
5. Keep your feet on the footrests.
6. Steer slightly into the hill.

NOTE: If the vehicle begins to tip, quickly turn the front wheels downhill (if possible) or dismount on the uphill side *immediately!*

 Always follow the procedures outlined in this manual for crossing the side of a hill.

Never attempt to turn the Quadricycle around on any hill until you've mastered (on level ground) the turning technique outlined in this manual.



SAFETY

Driving Safely

Driving Uphill

Whenever traveling uphill, follow these precautions:

1. Avoid steep hills (25° maximum).
2. Check the terrain carefully.
3. Avoid hills with excessively slippery or loose surfaces.
4. Shift your weight uphill.
5. Drive straight uphill.
6. Keep your feet on the footrests.
7. Drive at a steady rate of speed to avoid stalling.
8. Be alert. Be prepared to take emergency action. This may include dismounting quickly.
9. Never open the throttle suddenly or make sudden gear changes.
10. Never go over the top of a hill at high speed.

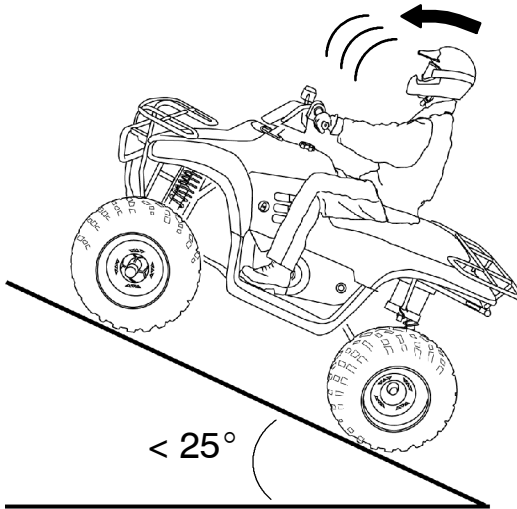

Driving Safely

Driving Uphill

If all forward speed is lost:

Keep your weight uphill.

If the vehicle begins rolling downhill, never apply engine power. Never apply the hand brake while rolling backwards.

Apply the foot brake gradually. When fully stopped, apply the hand brake as well. Lock the hydraulic parking brake.

Dismount on the uphill side, or to either side if the vehicle is pointed straight uphill. Turn the vehicle around and remount, following the procedure described on page 32.

-
- ⚠** Always follow the procedures outlined in this manual for climbing hills. Avoid climbing hills steeper than 25° .

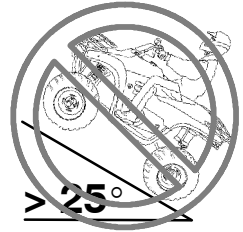

-
- ⚠** Always follow the procedures outlined in this manual for braking if you stall or roll backwards while climbing a hill. Never back down a hill.



SAFETY

Driving Safely

Turning Around on a Hill

If the vehicle stalls while climbing a hill, never back down the hill!
Use the K-turn to turn around.

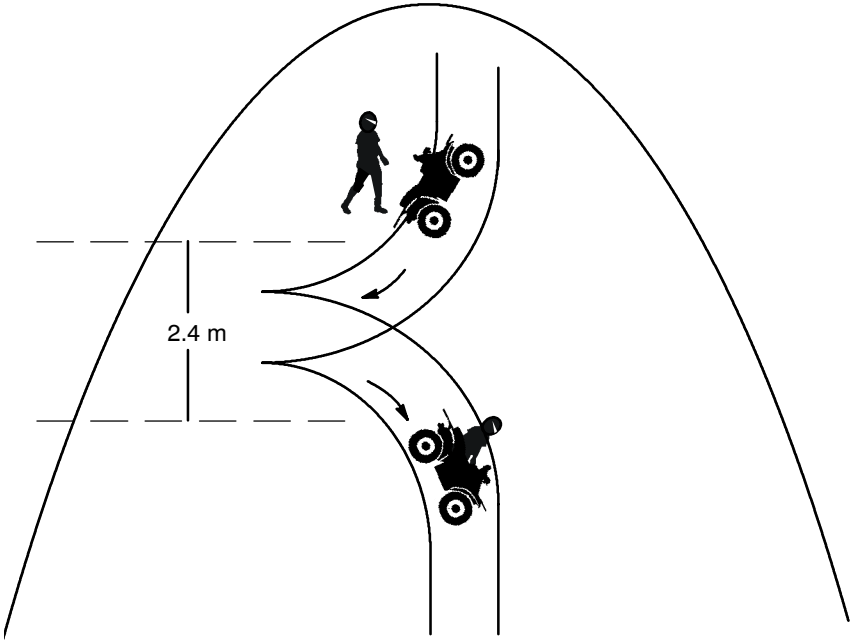

1. Stop the vehicle. Keep your weight uphill.
2. Lock the hydraulic parking brake.
3. Leave the transmission in forward gear. Turn the engine off.
4. Dismount on the uphill side of the vehicle, or on the left if the vehicle is pointing straight uphill.
5. Stay uphill of the vehicle and turn the handlebars full left.
6. Squeeze the brake lever to release the parking brake.
7. Slowly release the brake lever and allow the vehicle to roll around to your right until it's pointing across the hill or slightly downward.

Driving Safely

Turning Around on a Hill

8. Lock the hydraulic parking brake. Remount from the uphill side. Keep your weight uphill.
 9. Apply the foot brake.
 10. With the transmission still in forward, start the engine.
 11. Squeeze and release the brake lever to release the parking brake.
 12. Release the foot brake and drive *slowly* downhill. Control speed with the foot brake until the vehicle is on level ground.
-

- ⚠** Always follow the procedures outlined in this manual for climbing hills. See page 30.

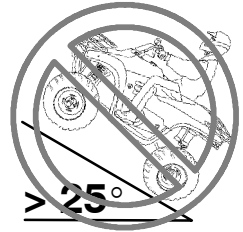

- ⚠** Always follow the procedures outlined in this manual for crossing the side of a hill. See page 29.



SAFETY

Driving Safely

Driving Through Water

Follow these procedures when operating through water:

1. Check water depth and current before crossing.
2. Avoid operating in water deeper than the bottom of the footrests (1).
If it's unavoidable, travel slowly, balance your weight carefully and avoid sudden movements. Maintain a slow and steady forward motion. Do not make sudden turns, stops or throttle changes.
3. Choose a crossing where both banks have gradual inclines.
4. Drive slowly.
5. Avoid rocks and obstacles.
6. Wet brakes may have reduced stopping ability. Always test your brakes after leaving water. If necessary, apply them lightly several times to allow friction to dry out the pads.



-
- ⚠** Always follow the procedures outlined in this manual for driving through water. Never drive through deep or fast-flowing water.



Driving Safely

Driving Through Water

CAUTION

If the vehicle stops while fully submerged, major engine damage can result if the machine is not thoroughly inspected. Take the vehicle to your dealer before starting the engine.

If your vehicle becomes fully immersed, and it's impossible to take it to a dealer before starting it, follow the steps described on page 92. Have the vehicle serviced by your dealer promptly.

NOTE: If water has been ingested into the transmission (PVT), follow the procedure on page 59.

SAFETY

Driving Safely

Driving in Reverse

Follow these precautions when operating in reverse:

1. Avoid backing downhill.
2. Always check for obstacles or people behind the vehicle before backing.
3. Drive slowly.
4. Apply the foot brake *lightly* for stopping.
5. Avoid turning at sharp angles.
6. Never apply the throttle suddenly.
7. Do not use the override switch unless additional power is required for vehicle movement. Use with caution.



NOTE: Reverse speed is greatly increased when the override switch is used. Do not operate at full throttle. Apply just enough throttle to maintain the desired speed.

CAUTION

Excessive throttle operation while in the speed limit mode may cause fuel to build in the exhaust, resulting in engine popping and/or engine damage.

-
-  Always follow the procedures outlined in this manual for driving in reverse.



Driving Safely

Parking on an Incline

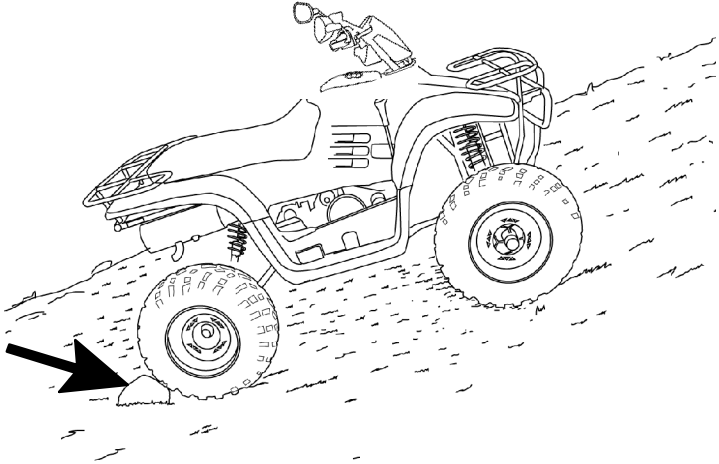

Avoid parking on an incline. If it's unavoidable, follow these precautions:

1. Turn the engine off.
2. Place the transmission in gear.
3. Lock the mechanical parking brake.
4. Always block the rear wheels on the downhill side.
5. Turn the fuel valve off.

SAFETY

Driving Safely

Hauling Cargo and Towing

WARNING

Overloading the vehicle or carrying or towing cargo improperly can alter vehicle handling and may cause loss of control or brake instability. Always follow these precautions when hauling cargo.

- Read and understand the load distribution warnings listed on the vehicle warning labels.
- Never exceed the stated load capacity for this vehicle.
- **REDUCE SPEED AND ALLOW GREATER DISTANCES FOR BRAKING WHEN HAULING CARGO OR TOWING.** Use extreme caution when applying brakes. Avoid situations that require backing downhill.
- When operating over rough or hilly terrain, reduce speed, cargo and towed load to maintain stable driving conditions.
- Do not obstruct the headlight when loading the front rack.
- **CARRY LOADS AS LOW ON THE RACK AS POSSIBLE.** Carrying a load high on the rack raises the center of gravity of the vehicle and creates a less stable operating condition. Reduce load weight when cargo is high. Secure off-centered loads that cannot be centered and operate with extra caution.
- **CARRYING A LOAD** on only one rack may cause the vehicle to overturn. Split the load between the front rack and rear rack, with 1/3 in the front and 2/3 in the back. Do not exceed load capacities. See specifications beginning on page 108.
- **SECURE ALL LOADS BEFORE OPERATING.** Unsecured loads can create unstable operating conditions, which could result in loss of control of the vehicle.
- **OPERATE ONLY WITH STABLE AND SAFELY ARRANGED LOADS.** When handling off-centered loads that cannot be centered, securely fasten the load and operate with extra caution. Always attach the tow load to the hitch point designated for your vehicle.
- **WHEN LOAD EXTENDS BEYOND RACK SIDES,** stability and maneuverability may be adversely affected, causing the machine to overturn. Use extreme caution.
- **TOWING** is approved **OFF-ROAD ONLY.** Operating a Quadricycle/trailer combination on public roads is prohibited.
- **TOWING SPEED** should never exceed 16 km/h. Never exceed 8 km/h when towing loads in rough terrain, while cornering, or while ascending or descending hills.

Driving Safely

Hauling Cargo and Towing

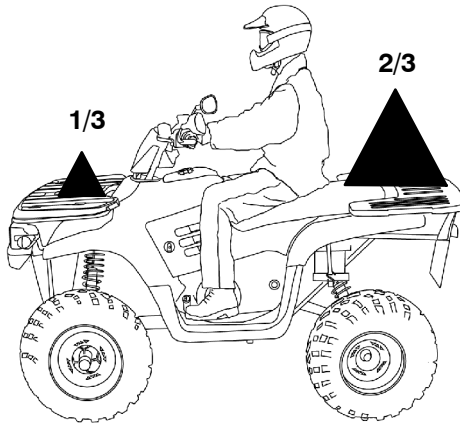

Towing

Towing is approved OFF-ROAD ONLY. Operating a Quadricycle/trailer combination on public roads is prohibited. Do not exceed the maximum capacities when towing. Do not tow any trailer on a grade steeper than 15°.



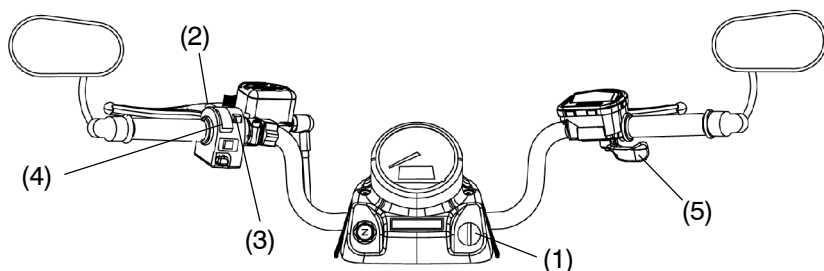

Trail Boss 330 QUADRICYCLE	Maximum Towed Load (Level Ground)	Maximum Vertical Hitch Weight
	386 kg	38.6 kg

FEATURES AND CONTROLS

Controls/Instruments



(1) Main Key Switch

-  Turn the main key switch off to stop the engine and end all electrical power to the vehicle.
-  Turn the switch on to engage the starter.
-  After starting the engine, release the key to the *RUNNING LIGHTS* position.
-  Turn the switch to *LIGHTS ON* to switch the headlights on.

WARNING

Do not attach a large key fob or key ring to the main switch. It may contact the gas tank cap when turning, causing an interruption to the electrical system and an unexpected engine shut-down during operation. This could result in serious injury or death.

(2) Speedometer Mode/Override Switch (Reverse Speed Limiter)

To gain additional power while operating in reverse, cancel the reverse speed limit function by pressing the override switch *before* opening the throttle.

WARNING

Activating the override switch with the throttle open and while operating in reverse can cause loss of control. Do not activate the override switch while the throttle is open.

FEATURES AND CONTROLS

Controls/Instruments

(3) Engine Stop Switch

- ⊗ Move the stop switch to the OFF position to stop the engine. All electrical power to the vehicle will end. The engine will not start or run when the switch is in the OFF position.
- Move the stop switch to the ON (RUN) position before attempting to start the engine.

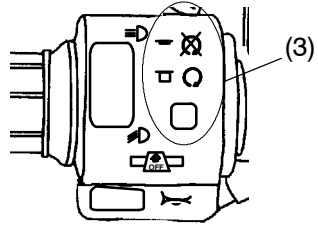

(4) Light Switch

Toggle the lights from high beam to low beam.

NOTE: The lights do not operate unless the main key switch is on and the engine stop switch is in the RUN position.

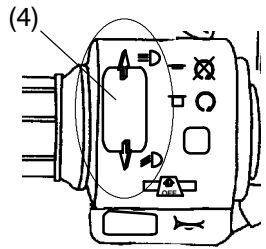

(5) Throttle lever

Press the throttle lever to increase engine speed and vehicle movement. Release the lever to reduce engine speed and vehicle movement.

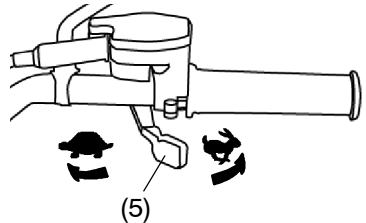

⚠ WARNING

Failure to check or maintain proper operation of the throttle system can result in an accident if the throttle lever sticks during operation. Check the lever for proper operation before starting the engine. Check occasionally during operation.

Do not start or operate a Quadricycle with sticking or improperly operating throttle controls.

Contact your dealer for repair if throttle problems arise.

FEATURES AND CONTROLS

Controls/Instruments

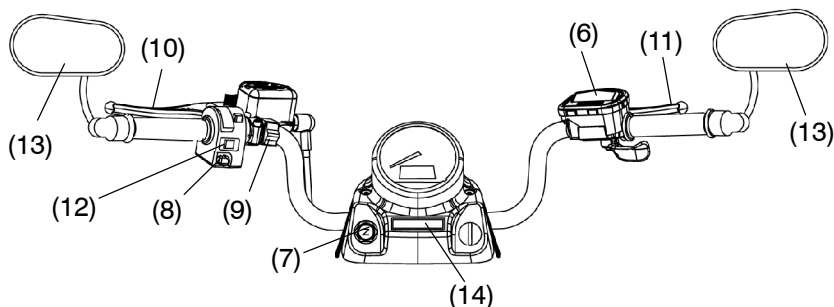

(6) Electronic Throttle Control (ETC)

ETC causes the engine to stop if the throttle cable sticks in an open position when the operator releases the throttle lever.

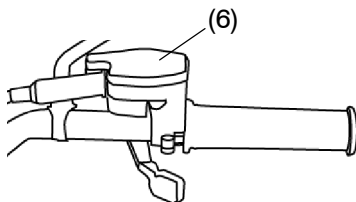

WARNING

The Electronic Throttle Control (ETC) stops the engine in the event of a throttle system malfunction. Do not modify the ETC system or replace it with other throttle mechanisms.

(7) Choke Knob

The choke assists in starting a cold engine. See page 57.

(8) Horn

 Press the horn button to alert others of your presence.

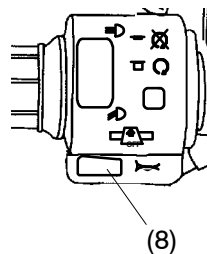

FEATURES AND CONTROLS

Controls/Instruments

(9) Hazard Warning Switch

 Push the hazard warning switch to cause all turn indicators to flash simultaneously. Use this feature to alert others of an emergency or other situation requiring caution.

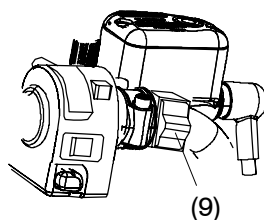

(10) Rear Brake Lever

The left brake lever operates the hydraulic rear brakes only. See page 44.

(11) Parking Brake Lever

The right brake lever is used as a mechanical parking brake only. See page 45.

(12) Turn Indicator

Push the toggle switch either left or right to activate the corresponding turn signal. Return the toggle to the center position to end the signal.

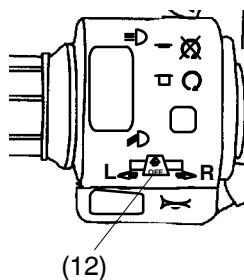

(13) Mirrors

Use the mirrors to assist in traffic maneuvers. Always check and adjust the mirrors before driving the Quadricycle.

(14) Instrument Panel

View certain vehicle functions on the instrument panel. The corresponding lights illuminate when the feature is activated.

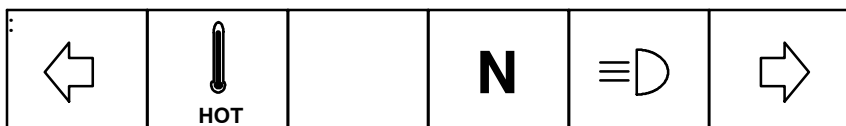

Left Turn

Engine Hot

Neutral

High Beam

Right Turn

FEATURES AND CONTROLS

Brakes

Foot Brake

The all-wheel foot brake (1) is located on the right footrest. The foot brake operates both front and rear brakes. Press the brake pedal forward with your foot to engage the all-wheel brakes.

The master cylinder (2) is located near the foot brake. Inspect and maintain the brake fluid level as outlined in this manual. See pages 56 and 75.

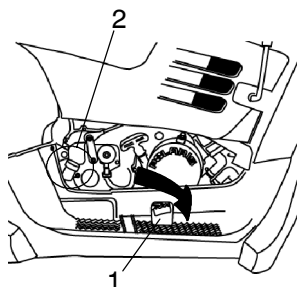

Rear Brake Lever

The left brake lever (1) operates the hydraulic rear brakes only. Squeeze the brake lever toward the handlebar to apply the rear brakes.

If the rear wheels begin to skid or slide while using this brake, *reduce* lever pressure.

Inspect and maintain the brake fluid level in the master cylinder (2) as recommended. See pages 56 and 75.

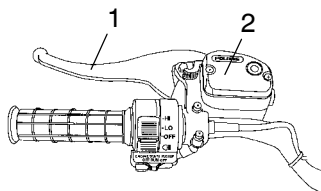

WARNING

Aggressively applying the rear brake when backing down a hill may cause rear tipover.

Aggressively applying the rear brake while moving forward may cause the rear wheels to skid and result in loss of control.

Read this owner's manual and understand the operation of all brake systems on this vehicle.

Always use caution whenever applying only the rear brakes.

FEATURES AND CONTROLS

Brakes

⚠ WARNING

Operating the Quadricycle while the parking brake is engaged could result in an accident and serious injury or death. Always check to be sure the parking brake is disengaged before operating.

Locking the Parking Brake (Mechanical)

The right brake lever is used as a mechanical parking brake only. It is not intended to be used as a brake lever.

1. Squeeze the right brake lever (1) toward the handlebar.
2. Move the park brake lock (2) toward the handlebar until the peg (3) fits into the slot on the lever. Release the lock lever.
3. To release the parking brake lock, squeeze and release the brake lever. The parking brake will release automatically.

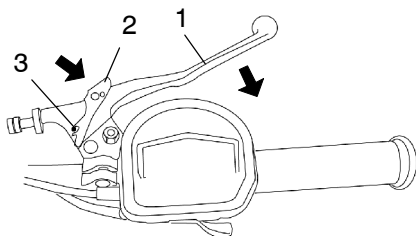

NOTE: The parking brake may relax if left on for a long period of time. Always block the wheels to prevent rolling. Never depend on the parking brake alone if the vehicle is parked on a hill. Always block the wheels to prevent rolling.

Locking the Parking Brake (Hydraulic)

The hydraulic parking brake lock is a temporary lock. Do not rely on the hydraulic parking brake when leaving the vehicle unattended. Always lock the *mechanical* parking brake.

1. Squeeze the left brake lever (1).
2. Move the park brake lock (2) to the locked position. This will prevent the lever from returning to the released position.
3. To release the parking brake lock, squeeze and release the brake lever. The parking brake will release automatically.

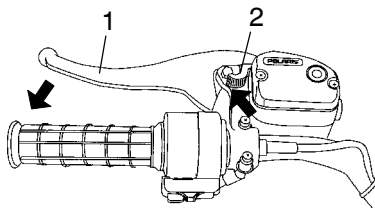

FEATURES AND CONTROLS

Steering Lock

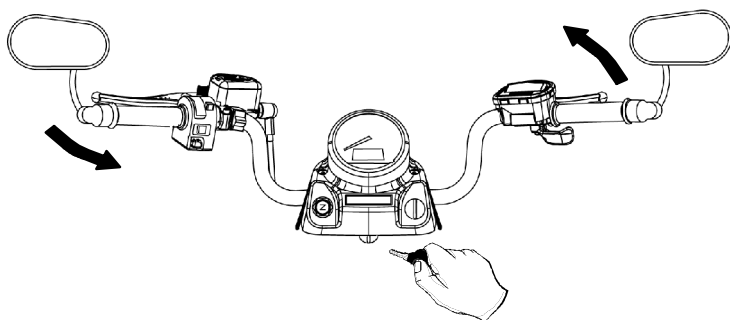

Lock the steering to prevent unauthorized use or theft of the vehicle.

1. Turn the handlebars to the full left position.
2. Insert the steering lock key and turn it clockwise.
3. Remove the key.
4. Reverse the procedure to unlock the steering.

NOTE: Place the steering lock keys in a safe place. The lock must be replaced if the keys are lost.

FEATURES AND CONTROLS

Fuel Tank

The fuel tank filler cap (1) is located directly below the handlebar. Refuel with either leaded or unleaded gasoline with a minimum of 87 octane.

WARNING

- Gasoline is highly flammable and explosive under certain conditions.
- Use extreme caution whenever handling gasoline.
- Refuel with the engine stopped. Refuel outdoors or in a well ventilated area.
- Never fill a fuel container while it's in the cargo box. Static electricity between the box and container could cause a spark.
- Do not smoke or allow open flames or sparks in or near the area where refueling is performed or where gasoline is stored.
- Do not overfill the tank. Do not fill the tank neck.
- If gasoline spills on your skin or clothing, immediately wash it off with soap and water and change clothing.
- Turn the fuel valve off whenever the vehicle is stored or parked.

Fuel Valve

The fuel valve (2) is located on the left side panel.

OFF

Turn the valve off before storage and when transporting.

ON

Turn the valve on for normal operation.

RES

Turn the valve to the reserve setting if the main fuel supply is exhausted. Refuel as soon as possible. Reserve fuel range is about 11-16 km.

NOTE: Return the valve to the ON position after refueling.

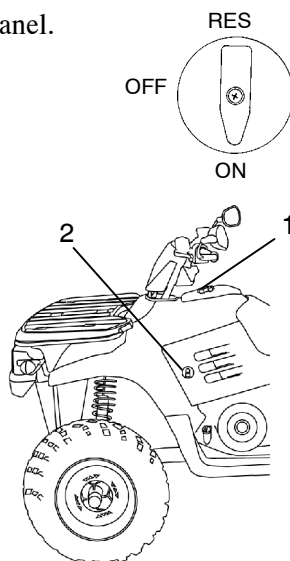

FEATURES AND CONTROLS

Transmission Gear Selector

The transmission gear selector (1) is located on the right side of the vehicle.

Whenever the vehicle is left unattended, place the transmission in gear and lock the mechanical parking brake.

F: Forward Gear

N: Neutral

R: Reverse

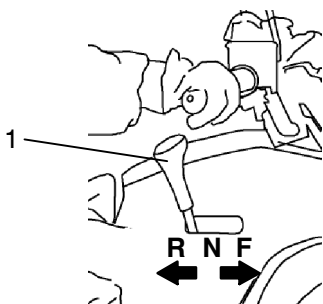

CAUTION

Shifting gears with the engine speed above idle or while the vehicle is moving can cause transmission damage. Stop the vehicle, release the throttle and move the lever to the desired gear. See your dealer if you experience any shifting problems.

FEATURES AND CONTROLS

Recoil Starter

If the battery is too weak to start the engine, use the recoil starter (1). Follow the starting procedures on page 57, cranking the engine with the recoil starter instead of the main key switch.

1. Grasp the recoil starter rope handle tightly. Pull slightly until the starter mechanism engages.
2. Pull the rope abruptly to start the engine.

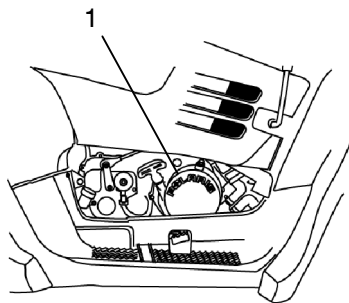

CAUTION

Extending the starter rope too far will cause damage to the recoil assembly. Do not extend the starter rope so far that it stops.

If the starter rope handle is not seated properly, water may enter the recoil housing and damage components. Make sure the handle is fully seated on the recoil housing, especially when traveling in wet areas.

FEATURES AND CONTROLS

Instrument Cluster

The instrument cluster senses vehicle speed from the right front wheel. It measures distance as well as hours of operation. It also includes a reverse speed limiter function that limits reverse speed to about 11-14 km/h. See page 40 for additional information.

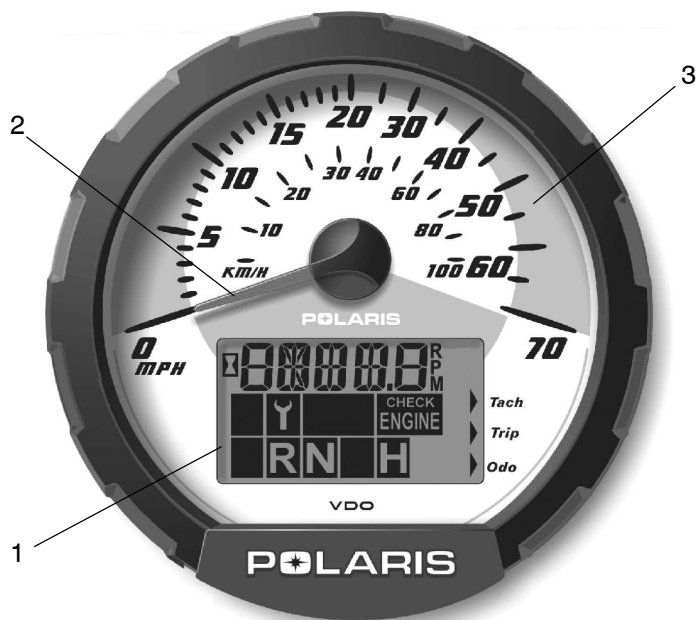

1. Rider Information Center
2. Speedometer needle (In addition to showing vehicle speed, the needle flashes when a warning condition exists.)
3. Speedometer

CAUTION

To prevent damage to the instrument cluster, wash the Quadricycle by hand or with a garden hose using mild soap.

Do not use alcohol to clean the instrument cluster.

Immediately wash off any gasoline that splashes on the instrument cluster.

FEATURES AND CONTROLS

Instrument Cluster

Rider Information Center

The rider information center is located in the instrument cluster. All segments will light up for 2.5 seconds at start-up.

NOTE: If the instrument cluster fails to illuminate, a battery over-voltage condition may have caused it to shut down to protect the electrical system. If this occurs, take the Quadricycle to your Polaris dealer.

1. **Gear Indicator** - As the shift lever is moved, this indicator shows the gear the transmission is in.
H = High Range (Forward)
N = Neutral
R = Reverse

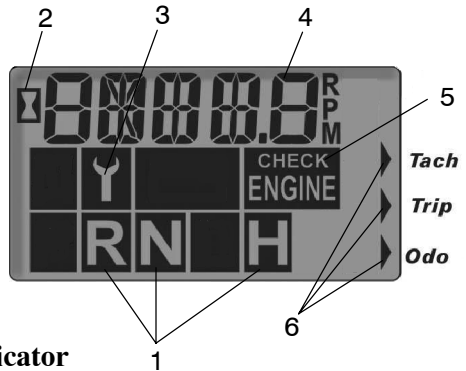

2. **Engine Hour Display Indicator**
3. **Service Interval/Diagnostic Mode Indicator**
4. **Odometer/Tachometer/Tripmeter/ Hour Meter**
5. **Check Engine Warning Indicator** - “HOT” will display when the engine is overheating. Turn off the engine or serious damage could result.
6. **Mode Indicator**

FEATURES AND CONTROLS

Instrument Cluster

Rider Information Center

The reverse override button on the left handlebar is also the *mode button*. Use the mode button to toggle through the four (4) standard modes of the rider information center.

NOTE: The transmission cannot be in reverse.

Mode 1 - Odometer

The odometer records the total distance traveled by the vehicle since manufacture.

Mode 2 -Trip Meter

The trip meter records the distance traveled on each trip if it's reset before each trip. To reset the trip meter, select the trip meter mode. Press and hold the mode button (override button) until the total changes to 0.

NOTE: The trip meter displays a decimal point, but the odometer does not.

Mode 3 - Hour Meter

The hour meter logs the total hours the engine has been in operation.

Mode 4 - Tachometer

The tachometer displays engine RPM. Small fluctuations in the RPM are normal due to changes in humidity, temperature and elevation.

FEATURES AND CONTROLS

Instrument Cluster

Rider Information Center

Diagnostic Mode

The diagnostic mode is for informational purposes only. Please return your Quadricycle to your dealer for all major repairs.

The wrench icon will display when the gauge is in the diagnostic mode.

Steps to enter the diagnostic mode:

1. Turn the main key switch off and wait 10 seconds.
2. Shift the transmission into neutral or park.
3. Hold the mode button and turn the main key switch on.
4. Release the switch as soon as the display is activated.
5. Use the mode button to toggle through the six (6) diagnostic screens.

Three (3) ways to leave the diagnostic mode:

- Shift the transmission out of neutral.
- Turn the main key switch off and on.
- Move the tires.

Screen 1: Battery voltage

Screen 2: Tachometer

Screen 3: AWD diagnostic

This screen indicates whether or not current is flowing through the AWD system.

Screen 4: Gear circuit diagnostic

This screen displays the resistance value (in ohms) being read at the gear switch input.

FEATURES AND CONTROLS

Instrument Cluster

Rider Information Center

Diagnostic Mode

Screen 5: Programmable service interval

The programmable service interval provides a convenient reminder when routine maintenance is due. This feature is pre-set at 50 hours.

You must enable the programmable service interval before it can be used.

When set, the hours of operation are subtracted from the set hours until 0 is reached. The wrench icon will flash quickly for five seconds each time the engine is started as a reminder that service is due.

Setting the Service Interval

1. Press and hold the mode/override button until the wrench icon flashes. Release the button.
2. Press the button once to advance the setting by one hour. Press and hold the button to advance the hours at a faster pace.
3. When the desired time increment is displayed, release the button. When the wrench stops flashing, service hours are set.

NOTE: If you scroll past the intended number, hold the button down until the count turns over to 0. You can then reset the number.

Disabling the Service Interval

1. Toggle to the service interval mode.
2. Press and hold the mode button for approximately seven (7) seconds. The service interval is disabled when the word *OFF* displays.

Screen 6: Miles/Kilometers toggle

The display in the tripmeter and odometer can be changed to display either kilometers or miles. The current display mode will be shown as either KM or MP.

1. Press and hold the mode button until the letters flash.
2. Press and release the mode button once. When the display stops flashing, the mode has been set.

Break-In Period

The break-in period for your new Polaris Quadricycle is the first ten hours of operation, or the time it takes to use the first two full tanks of gasoline. No single action on your part will increase the life and performance of your Quadricycle more than following the procedures for a proper break-in. Careful treatment of a new engine will result in more efficient performance and a longer life.

Do not operate at full throttle or high speeds for extended periods during the first three hours of use.

Perform the following procedures carefully.

1. Fill the fuel tank with gasoline.
2. Check the oil level on the dipstick. Add oil if necessary. See page 67.
3. Select an open area that allows room to familiarize yourself with vehicle operation and handling.
4. Drive slowly. Vary throttle positions. Do not operate at sustained idle.
5. Perform regular checks on fluid levels, controls and areas outlined on the daily pre-ride inspection checklist. See page 56.
6. Pull only light loads.
7. Perform the break-in oil change at one month.

OPERATION

Pre-Ride Inspection

Pre-Ride Checklist		
Item	Remarks	See Page
Brake system	Ensure proper operation	74
Brake fluid	Ensure proper level	75
Foot brake	Ensure proper operation	44
Front suspension	Inspect, lubricate if necessary	65
Rear suspension	Inspect, lubricate if necessary	65
Steering	Ensure free operation	-
Tires	Inspect condition and pressure	82
Wheels / fasteners	Inspect, ensure fastener tightness	81
Drive chain	Inspect condition, lubricate frequently	83
Frame nuts, bolts, fasteners	Inspect, ensure tightness	-
Fuel and oil	Ensure proper levels	47, 67
Throttle	Ensure proper operation	41, 79
Indicator lights / switches	Ensure operation	40
Engine stop switch	Ensure proper operation	41
Air filter, pre-filter	Inspect, clean	85
Air box sediment tube	Drain deposits whenever visible	-
Headlamp	Check operation, apply Polaris dielectric grease when lamp is replaced	86
Brake light / tail lamp	Check operation, apply Polaris dielectric grease when lamp is replaced	88
Riding gear	Wear helmet, goggles, protective clothing	23

Starting the Engine

⚠ WARNING

Engine exhaust contains poisonous carbon monoxide and can cause loss of consciousness resulting in serious injury or death. Never run an engine in an enclosed area or indoors.

CAUTION

Operating the vehicle immediately after starting could cause engine damage. Allow the engine to warm up for several minutes before operating.

1. Position the vehicle on a level surface.
2. Sit on the vehicle.
3. Lock the mechanical parking brake.



4. Turn the fuel valve on.
5. Move the engine stop switch to RUN.

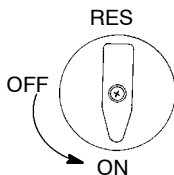

6. If the engine is cold, pull the choke knob (1) out until it stops. A warm engine will not require the use of the choke.

FULL ON



HALF ON



OFF

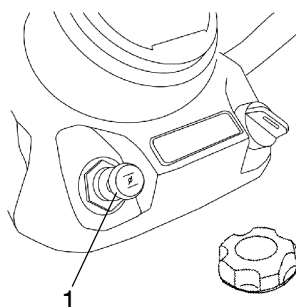

NOTE: Make sure the choke is off during operation. Excess fuel washing into the engine oil will increase wear on engine components.

OPERATION

Starting the Engine

7. Turn the ignition key to the ON position to engage the starter. Activate the starter for a maximum of five seconds, releasing the key when the engine starts.

NOTE: Do not press the throttle while starting the engine.

8. If the engine does not start, release the starter and wait five seconds.

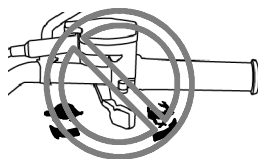
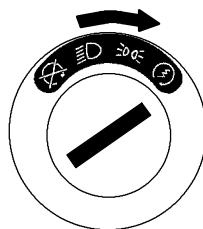

-
9. Repeat steps 7 and 8 until the engine starts.
 10. If the engine slows or stops, position the choke knob half way in.
 11. Vary engine RPM slightly with the throttle. When the engine idles smoothly, push the choke all the way in.
-

Polaris Variable Transmission

Preventing Belt Slip / Failure

Belt slip creates heat that destroys belts and causes outer clutch covers to fail. **Avoid heavy pulling and extended low speed operation.**

WARNING

Do not modify any component of the PVT system. Doing so may reduce its strength so that a failure may occur at a high speed.

The PVT system has been precision balanced. Any modification will cause the system to be out of balance, creating vibration and additional loads on components.

The PVT system rotates at high speeds, creating large amounts of force on clutch components. Extensive engineering and testing has been conducted to ensure the safety of this product. However, as the owner, you have the following responsibilities to make sure this system remains safe:

- Always follow all recommended maintenance procedures. See your dealer as outlined in the owner's manual.
- This PVT system is intended for use on Polaris products only. Do not install it in any other product.
- Always make sure the PVT housing is securely in place during operation.

PVT Drying

If water is ingested into the PVT system, dry it before operating the vehicle.

1. Remove the drain plug. Drain the water. Reinstall the drain plug.
2. Place the transmission in neutral. Lock the mechanical parking brake. Start the engine.
3. Apply varying throttle for 10-15 seconds to expel the moisture and air-dry the belt and clutches. Do not hold the throttle wide open.
4. Allow the engine RPM to return to idle speed, then shift the transmission to the lowest available range.
5. Test for belt slippage. If the belt slips, repeat the process.
6. Take the vehicle to your dealer for service promptly.

EMISSION CONTROL SYSTEMS

Noise Emission Control System

Do not modify the engine, intake or exhaust components, as doing so may affect compliance with governmental noise level requirements.

Spark Arrestor

Your Polaris vehicle has a spark arrestor that was designed for on-road and off-road operation. It is required that this spark arrestor remain installed and functional when the vehicle is operated.

Crankcase Emission Control System

This engine is equipped with a closed crankcase system. Blow-by gases are forced back to the combustion chamber by the intake system. The system does not allow the blow-by gases to enter the atmosphere.

Exhaust Emission Control System

The emissions from the exhaust of this vehicle are controlled by engine design, including factory-set fuel delivery and ignition. The engine and related components must be maintained at Polaris specifications to achieve optimal performance.

The emissions label (1) is located on the recoil cover.

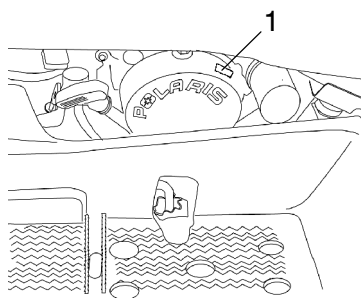

Adjustment to engine idle is the only adjustment recommended that the operator perform. Any other adjustments should be performed by an authorized Polaris dealer.

Electromagnetic Interference

This spark ignition system complies with USA requirements, Canadian ICES-002 and European directives 89/336/EEC and 97/24/EC.

MAINTENANCE AND LUBRICATION

Periodic Maintenance Chart

Maintenance intervals in the following chart are based upon average riding conditions. Vehicles subjected to severe use must be inspected and serviced more frequently.

Severe Use Definition

- Frequent immersion in mud, water or sand
- Racing or race-style high RPM use
- Prolonged low speed, heavy load operation
- Extended idle
- Short trip cold weather operation

NOTE: Service and adjustments are critical. If you are not familiar with safe service and adjustment procedures, have a qualified Polaris dealer perform these operations.

The programmable service interval mode on the instrument cluster will help determine when maintenance service is due. See page 54.

Maintenance Chart Key

- ▶ Perform these procedures more frequently for vehicles subjected to severe use.
- E Emission Control System Service
- Have an authorized Polaris dealer perform these services.

WARNING

Improperly performing the procedures marked with a ■ could result in component failure and lead to serious injury or death. Have an authorized Polaris dealer perform these services.

MAINTENANCE AND LUBRICATION

Periodic Maintenance Chart

Perform all services at whichever maintenance interval is reached first.

Item		Maintenance Interval (whichever comes first)			Remarks	
		Hours	Calendar	Kilometers		
■	Steering	-	Pre-Ride	-	Make adjustments as needed. See Pre-Ride Checklist on page 56.	
▶	Front suspension	-	Pre-Ride	-		
▶	Rear suspension	-	Pre-Ride	-		
	Tires	-	Pre-Ride	-		
▶	Brake fluid level	-	Pre-Ride	-		
▶	Brake lever travel	-	Pre-Ride	-		
	Brake systems	-	Pre-Ride	-		
	Wheels/fasteners	-	Pre-Ride	-		
	Drive chain	-	Pre-Ride	-		
	Frame fasteners	-	Pre-Ride	-		
▶ E	Engine oil level	-	Pre-Ride	-		
▶ E	Air filter, pre-filter	-	Daily	-		Inspect; clean often
▶ E	Air box sediment tube	-	Daily	-		Drain deposits when visible
	Headlamp/tail lamp	-	Daily	-	Check operation; apply dielectric grease if replacing	
▶ E	Air filter, main element	-	Weekly	-	Inspect; replace as needed	
	Recoil housing	-	Weekly	-	Drain water as needed, check often if operating in wet conditions	
▶ ■	Brake pad wear	10	Monthly	100	Inspect periodically	
	Battery	20	Monthly	200	Check terminals; clean; test	
▶	Transmission oil	25	Monthly	250	Inspect level; change yearly	
▶ E	Engine breather filter	25	Monthly	250	Inspect; replace if necessary	
▶ E	Engine oil change (break-in)	25	1 M	250	Perform a break-in oil change at one month	
▶	General lubrication	50	3 M	500	Lubricate all fittings, pivots, cables, etc.	

▶ Perform these procedures more often for vehicles subjected to severe use.

E Emission Control System Service

■ Have an authorized Polaris dealer perform these services.

MAINTENANCE AND LUBRICATION

Periodic Maintenance Chart

Item		Maintenance Interval (whichever comes first)			Remarks
		Hours	Calendar	Kilometers	
	Carburetor float bowl	50	6 M	500	Drain bowl periodically and prior to storage
■ E	Throttle Cable/ ETC Switch	50	6 M	500	Inspect; adjust; lubricate; replace if necessary
■ E	Choke cable	50	6 M	500	Inspect; adjust; lubricate; replace if necessary
E	Carburetor air intake ducts/ flange	50	6 M	500	Inspect ducts for proper sealing/air leaks
	Drive belt	50	6 M	500	Inspect; adjust; replace as needed
▶ E	Engine oil change	100	6 M	1000	Perform a break-in oil change at one month
▶ E	Oil filter change	100	6 M	1000	Replace with oil change
■ E	Valve clearance	100	12 M	1000	Inspect; adjust
■ E	Fuel system	100	12 M	1000)	Check for leaks at tank cap, lines, fuel valve, filter, pump, carburetor; replace lines every two years
■ E	Fuel filter	100	12 M	1000	Replace yearly
▶	Engine mounts	100	12 M	1000	Inspect
	Exhaust muffler/ pipe	100	12 M	1000	Inspect
■ E	Spark plug	100	12 M	1000	Inspect; replace as needed
■ E	Ignition Timing	100	12 M	1000	Inspect
▶	Wiring	100	12 M	1000	Inspect for wear, routing, security; apply dielectric grease to connectors subjected to water, mud, etc.

▶ Perform these procedures more often for vehicles subjected to severe use.

E Emission Control System Service

■ Have an authorized Polaris dealer perform these services.

MAINTENANCE AND LUBRICATION

Periodic Maintenance Chart

Item		Maintenance Interval (whichever comes first)			Remarks
		Hours	Calendar	Kilometers	
■	Clutches (drive and driven)	100	12 M	1000	Inspect; clean; replace worn parts
■	Front wheel bearings	100	12 M	1600	Inspect; replace as needed
■	Brake fluid	200	24 M	2000	Change every two years
	Spark arrestor	300	36 M	3000	Clean out
E	Idle speed	-			Adjust as needed
■	Toe adjustment	-			Inspect periodically; adjust when parts are replaced
▶ ■	Foot brake and rear brake	-			Inspect daily; adjust as needed
▶ ■	Mechanical parking brake	-			Inspect daily; adjust cable as needed
	Headlight aim	-			Adjust as needed

▶ Perform these procedures more often for vehicles subjected to severe use.

E Emission Control System Service

■ Have an authorized Polaris dealer perform these services.





MAINTENANCE AND LUBRICATION

Torque Symbol

τ = Torque the item as specified.

Lubrication Recommendations

Check and lubricate all components at the intervals outlined in the Periodic Maintenance Chart beginning on page 61. Items not listed in the chart should be lubricated at the General Lubrication interval.

Item	Lube	Method
Engine	 Polaris Premium 4 Synthetic 0W40	See page 66.
Brakes	 DOT 3 fluid only	See page 74.
Transmission	 Premium AGL Synthetic Gearcase Lube	See Page 72.
Drive chain(s)	O-ring chain lube or SAE 80/90	Lubricate as often as required and before each ride in wet conditions
(1) Ball Joint	 Premium U-Joint Grease	Locate fittings and grease.
(2) Swing Arm Bushings		
(3) Axle Housing		

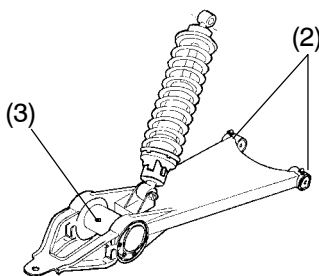
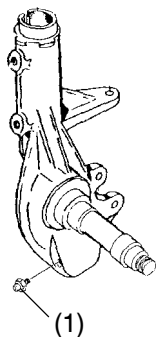

MAINTENANCE AND LUBRICATION

Engine Oil

Polaris Premium 4 Synthetic Oil is the only oil recommended for use in this engine. Use of another API certified “SH” oil is acceptable as long as it’s 0W-40. Oil may need to be changed more frequently if Polaris Premium 4 is not used. See page 103 for the part numbers of Polaris products.

Always check and change the engine oil at the intervals outlined in the Periodic Maintenance Chart beginning on page 61.

CAUTION

Using a non-recommended oil may cause serious engine damage. Use only Polaris Premium 4 All Season Synthetic Oil or an API certified 0W-40 “SH” oil. Never substitute or mix oil brands.

MAINTENANCE AND LUBRICATION

Oil Check

1. Position the vehicle on a level surface.
2. Place the transmission in neutral.
3. Lock the mechanical parking brake.

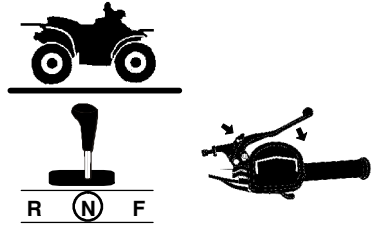

4. Start the engine. Allow it to idle for 30 seconds.
5. Turn the engine off.

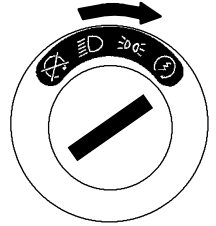

6. Remove the dipstick. Wipe it clean.

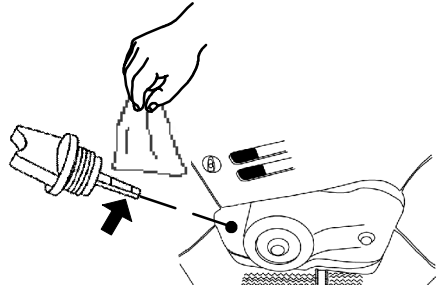

7. Reinstall the dipstick completely.
8. Remove the dipstick. Check the oil level.

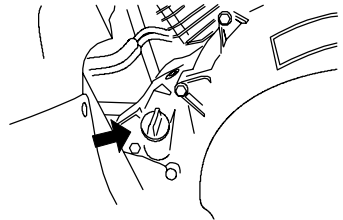

9. Add oil as needed to bring the level between the minimum and maximum marks.

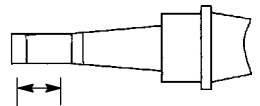

MAINTENANCE AND LUBRICATION

Oil and Filter Change

Always change the engine oil at the intervals outlined in the Periodic Maintenance Chart beginning on page 61. Always change the oil filter when changing oil. Change the oil more often if the vehicle is routinely subjected to:

- operation in dusty or wet conditions.
- operation when air temperature is below -12°C .
- short trips at -12° to -1°C . (engine fails to reach operating temperature).

CAUTION

If the Quadricycle is left without oil in the system for extended periods, the oil pump may lose its prime, which could result in engine damage. Always replace the oil and filter within a few hours of draining the oil. Do not allow the vehicle to be without oil overnight.

1. Use Polaris-recommended products.

- Oil filter
- 0W/40 oil



-
1. Position the vehicle on a level surface.
 2. Place the transmission in neutral.
 3. Lock the mechanical parking brake.

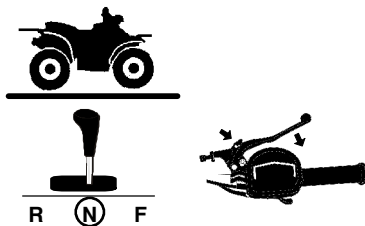

-
4. Start the engine. Allow it to idle for two minutes.
 5. Turn the engine off.

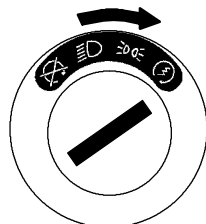

MAINTENANCE AND LUBRICATION

Oil and Filter Change

6. Place a drain pan under the vehicle.
7. Remove the drain plug.
8. Drain the oil.

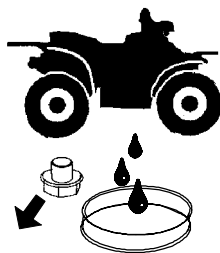

⚠ CAUTION

Hot oil may result in serious burns. Do not allow hot oil to contact skin.

9. Reinstall the drain plug with a new sealing washer.

$\tau = 19 \text{ N}\cdot\text{m}$

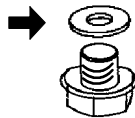

10. Place towels under the oil filter.
11. Using an oil filter wrench (4), turn the filter counterclockwise to remove it.

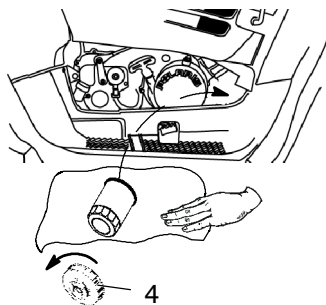

12. Clean the filter sealing area on the engine.

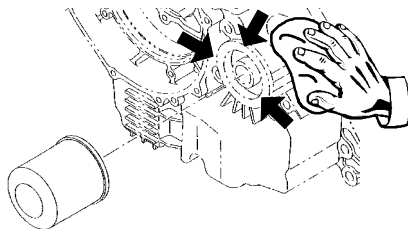

MAINTENANCE AND LUBRICATION

Oil and Filter Change

13. Lubricate the filter o-ring.

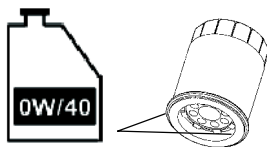

14. Install the new oil filter.
After the filter contacts the engine surface, turn it 1/2 turn by hand.

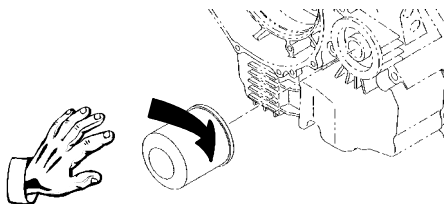

15. Remove the dipstick.

16. Add two .95 liter bottles of 0W/40 oil.

17. Reinstall the dipstick.

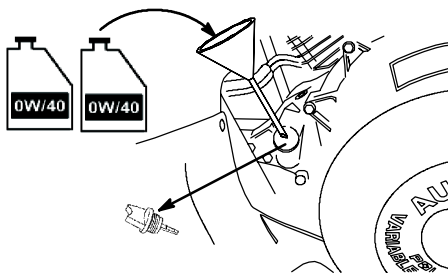

18. Start the engine. Allow it to idle for two minutes.

19. Turn the engine off.

20. Check for oil leaks.

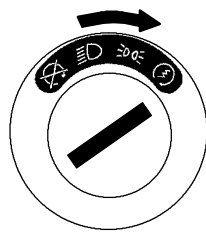

21. Check the oil level. Add oil as needed to bring the level between the minimum (MIN) and maximum (MAX) marks.

22. Discard used oil and filter properly.

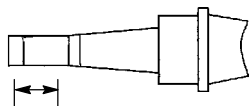

MAINTENANCE AND LUBRICATION

Engine Oil Cooler Maintenance

The oil cooling system requires little maintenance other than keeping the cooler (1) free of mud and debris.

CAUTION

Do not use a high pressure washer to remove debris from the cooler. The pressure may damage the cooling fins. Use only low pressure water.

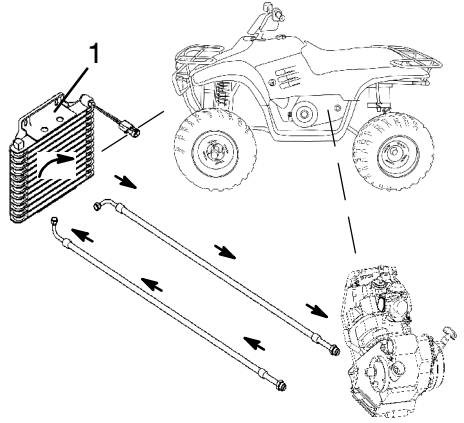

MAINTENANCE AND LUBRICATION

Transmission Oil Check

See page 65 for recommended lubricants. See page 103 for the part numbers of Polaris products.

1. Position the vehicle on a level surface.
2. Place the transmission in gear.
3. Lock the mechanical parking brake.

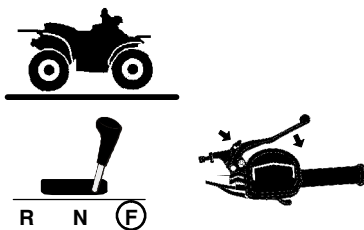

-
4. Remove the dipstick. Wipe it clean.
 5. Reinstall the dipstick completely.
 6. Remove the dipstick. Check the oil level.

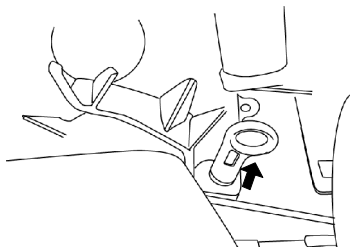

-
7. Maintain the level between the minimum (MIN) and maximum (MAX) marks.

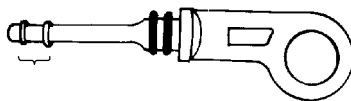

-
8. Add fluid as needed. Do not overfill.
 9. Reinstall the dipstick.

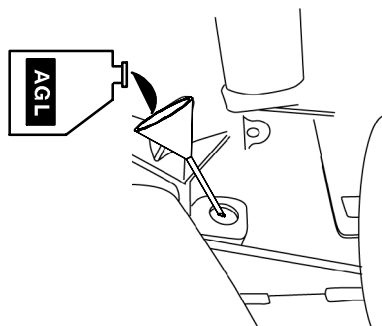

MAINTENANCE AND LUBRICATION

Transmission Oil Change

1. Position the vehicle on a level surface.
2. Place the transmission in gear.
3. Lock the mechanical parking brake.

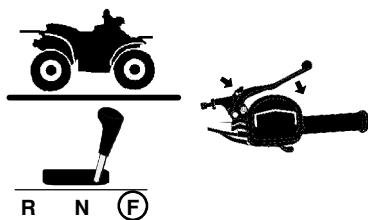

4. Loosen the jam nut (1).
5. Turn the adjuster bolt (2) inward.
6. Remove the drain plug (3). Wipe it clean.

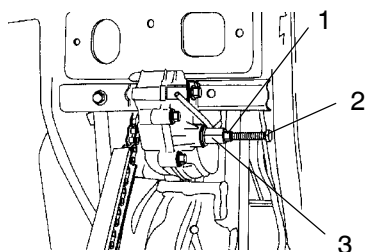

7. Drain the fluid into a drain pan.



8. Install a new sealing washer.
Reinstall the drain plug.

$\tau = 19 \text{ N}\cdot\text{m}$

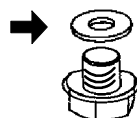

9. Turn the adjuster bolt outward until it touches the frame, and then turn an additional 1/2 turn.
10. Tighten the jam nut securely while holding the adjuster bolt.
11. Remove the dipstick.
12. Add 335 ml of the recommended fluid.
13. Reinstall the dipstick.
14. Check for oil leaks.

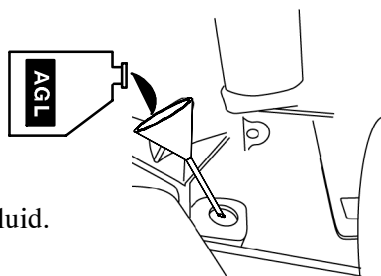

MAINTENANCE AND LUBRICATION

Brakes

Under normal operation, a diaphragm extends into the reservoir as fluid level drops. If the fluid level is low and the diaphragm is not extended, a leak is likely. The brake system should be inspected by your dealer. Fill the reservoir as needed whenever the cover is loosened or removed to ensure proper diaphragm operation. Use Polaris DOT 3 brake fluid. Do not overfill.

NOTE: Reservoir levels will decrease as brake pads become worn. When checking the fluid level, the vehicle must be on level ground with the handlebars straight. If the fluid level is low, check brake pad thickness before adding brake fluid. **DO NOT OVERFILL.**

Brake Check

Perform the following checks to keep the brake systems in good operating condition. Check more often if brakes are used heavily during normal operation.

⚠ WARNING

Do not overfill the reservoirs. An over-full master cylinder may cause brake drag or brake lock-up, which could cause brake loss or loss of control. Maintain brake fluid at the recommended level.

1. Check the brake systems regularly for fluid leaks.
2. Check the brakes for excessive travel or spongy feel.
3. Check the brake pads for wear, damage or looseness. Replace pads when they are worn to 1 mm.
4. Check the security and surface condition of the brake discs.

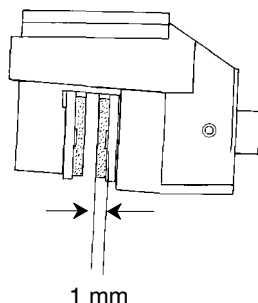

MAINTENANCE AND LUBRICATION

Brakes

Brake Fluid Check

Check brake fluid levels before each use of the vehicle.

The brakes should feel firm when they're applied. Spongy or weak brakes may indicate a fluid leak or low fluid level. A low fluid level may also mean that brake pads are worn and need to be replaced. Do not operate the vehicle with spongy or weak brakes. See your dealer for service.

Master Cylinder (Handlebar)

The master cylinder (1) is located on the left handlebar. View the fluid level through the indicator window (eye) on the top of the master cylinder.

A dark eye (2) indicates a full fluid level.

A clear eye (3) indicates a low fluid level.

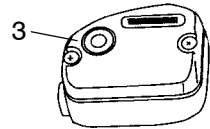
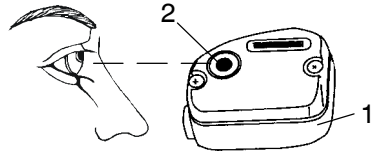

Master Cylinder (Foot Brake)

The foot brake master cylinder (4) is located under the right rear fender. View the fluid level through the reservoir body. Fluid level is full at the MAX mark. Add brake fluid if the level reaches the MIN mark.

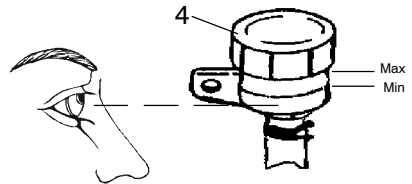

WARNING

Once open, a bottle of brake fluid absorbs moisture from the air, which causes the boiling temperature of the brake fluid to drop. This can lead to early brake fade and the possibility of accident. Do not store opened brake fluid. Properly discard any unused portion.

MAINTENANCE AND LUBRICATION

Steering / Suspension

Toe Alignment

Use the following procedure to check the toe alignment of the vehicle. The recommended toe alignment is 3-6 mm toe out.

1. Set the handlebars in a straight-ahead position.
2. Place stands (1) in front of the vehicle, perpendicular to the rear tires.
3. Tie an elastic string around the stands, making sure the string just touches the side surface of the rear tires on each side of the vehicle and goes around the stands in front of the vehicle (2).
4. Measure the distance from the string to the rim at the front and rear of the front rim (3). The rear measurement should be 2 to 3 mm more than the front measurement.

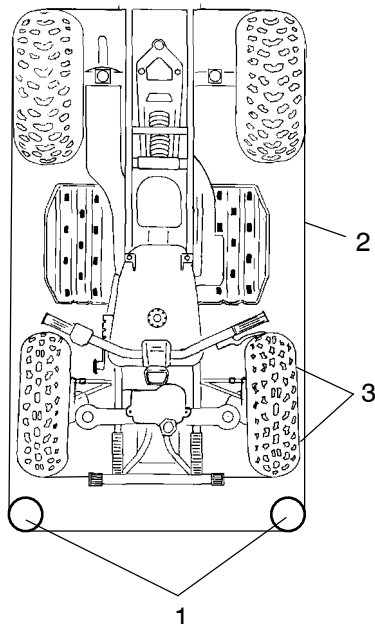

NOTE: If you discover improper alignment, see your Polaris dealer for service.

WARNING

Do not attempt to adjust alignment. All steering adjustments should be performed by an authorized Polaris dealer.

Rear Springs

The rear shock absorber springs are adjustable. Use the spanner wrench (1) in the tool kit.

Rotate the adjuster (2) clockwise to increase or counterclockwise to decrease spring tension.

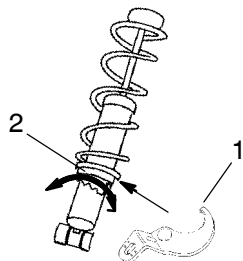

MAINTENANCE AND LUBRICATION

Steering / Suspension

Steering Assembly

Check the steering assembly of the vehicle periodically for loose nuts and bolts. If loose nuts and bolts are found, see your Polaris dealer for service before operating the vehicle.

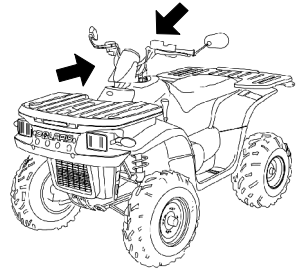

Handlebar Adjustment

1. Remove the two hex screws (1) from the instrument panel (2). Remove the instrument panel.
2. *Loosen* (do not remove) all four handlebar bolts.
3. Adjust the handlebar to the desired height.

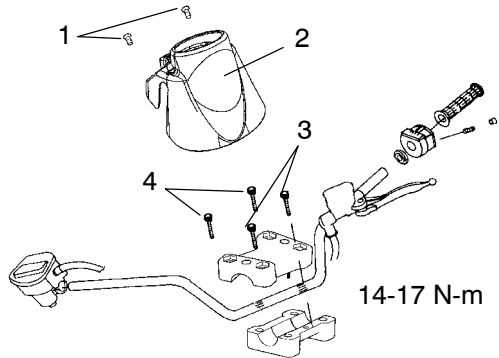

NOTE: Make sure the handlebars do not contact the gas tank or any part of the machine when turned fully to the left or right.

4. Torque the two front bolts (3), then torque the two rear bolts (4).

$\tau = 14-17 \text{ N-m}$

NOTE: A gap of up to 3 mm should remain at the rear bolts.

WARNING

Improper adjustment of the handlebars or incorrect torquing of the adjuster block tightening bolts can cause limited steering or loosening of the handlebars, resulting in loss of control. Follow the adjustment procedures exactly, or see your Polaris dealer for service.

MAINTENANCE AND LUBRICATION

Carburetor Idle Adjustment

IMPORTANT: Your Polaris vehicle is calibrated at the factory for optimal performance at altitudes ranging from zero to 1800 meters and at temperatures of 4 degrees C. or higher. Above 1800 meters the engine air/fuel mixture becomes too rich and the engine loses approximately 3% of its power for each 300 meter increase in elevation. Although this power cannot be regained, adjustments to the carburetor and drive system can be made to allow more efficient operation. Optional jets and clutch components, available from your Polaris dealer, are required for operation above 1800 meters. Jetting is required only when operating below 4 degrees C. at 1800 meters and lower.

NOTE: Operating the engine with improper jetting can cause poor performance, overheating or engine damage. See your Polaris dealer for more information about jetting.

If necessary, the carburetor can be adjusted.

1. Place the transmission in neutral.
2. Lock the mechanical parking brake.
3. Operate the engine for about five minutes.



-
4. Adjust the carburetor idle screw (1) clockwise to raise RPM or counterclockwise to lower RPM.

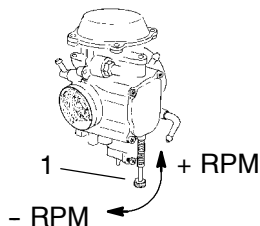

MAINTENANCE AND LUBRICATION

Throttle Cable Freeplay Adjustment

1. Locate the throttle cable adjuster (1) on the handlebar.

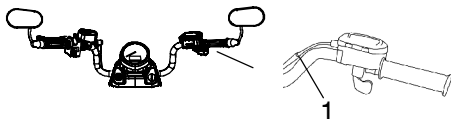

2. Slide the boots (2) off the cable adjuster sleeve (3). Loosen the adjuster (4).

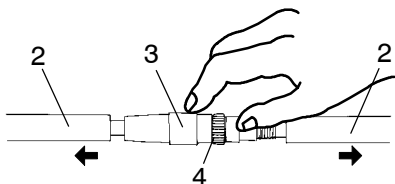

3. Turn the adjuster until 1.6-3.2 mm of freeplay exists at the lever.

NOTE: Move the throttle lever back and forth while adjusting.

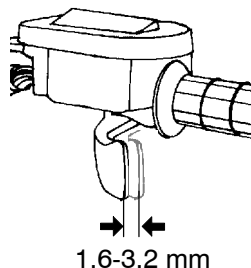

4. Tighten the adjuster. Slide the boots (2) over the cable adjuster until they touch at the midpoint of the adjuster.

NOTE: Engine RPM should not increase when steering is turned full left or right. Readjust cable freeplay if this occurs.

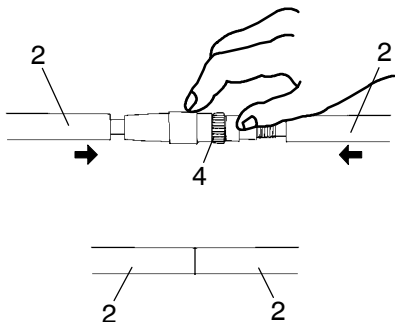

MAINTENANCE AND LUBRICATION

Side Panel Removal

NOTE: Side panel removal may be difficult until the locking tabs and receivers have been snapped and unsnapped a few times.

1. Remove the seat.
2. Grasp the rear of the side panel near the rear cab. Pull the panel forward and outward quickly and firmly to disengage the rear tabs.

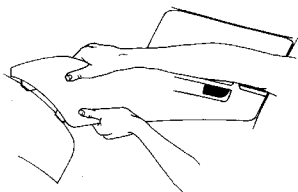

-
3. Place your hand on top of the side panel behind the fuel tank. Push down quickly and firmly to disengage the top rear tabs.
 4. Pull the side panel upward to disengage the front tabs.

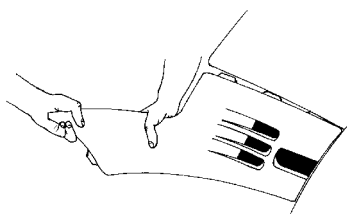

Reinstallation

5. Align the tabs with the slots on the front cab.
6. Push the panel upward and forward until the tabs lock.
7. Bend the rear of the side panel and insert the two tabs into the rear cab slots.

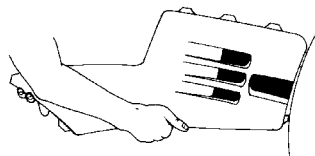

MAINTENANCE AND LUBRICATION

Wheel Removal / Installation

CAUTION

Operating with improperly installed wheels will affect vehicle handling and could cause an accident resulting in serious injury or death. Always use original equipment size and type when replacing tires. Install wheels properly.

1. Position the vehicle on a level surface.
2. Place the transmission in gear.
3. Lock the mechanical parking brake.

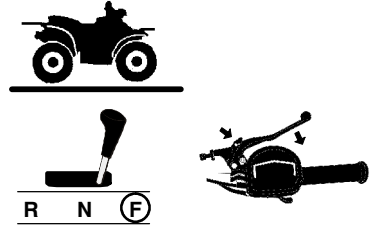

4. Loosen the wheel nuts slightly.
5. Safely place jackstands under the vehicle.



6. Remove the wheel nuts and remove the wheel.

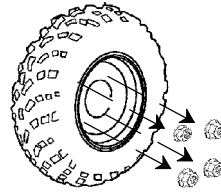

7. Place the wheel on the hub.
8. Install the wheel nuts finger tight.

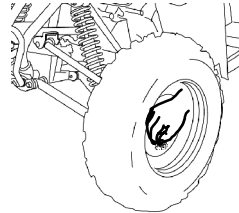

9. Carefully remove the jackstands.
10. Torque the wheel nuts.

$\tau = 37$ N-m Front Wheel

$\tau = 68$ N-m Rear Wheel



MAINTENANCE AND LUBRICATION

Tires

Tire Tread Depth

Always replace tires when tread depth is worn to 3 mm or less.

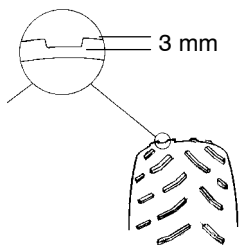

⚠ WARNING

Operating your vehicle with worn tires, improperly inflated tires, non-standard tires or improperly installed tires will affect vehicle handling and could cause an accident.

Maintain proper tire pressure as described on the decal on your vehicle and in the specifications section of the owner's manual beginning on page 108.

Use only original equipment size and type when replacing tires.

Make sure the wheels are installed properly.

Replace tires when the tread depth measures 3 mm or less.

Wheel and Hub Tightening

Wheel hub and bearing tightness and spindle nut retention are critical items. These services must be performed by an authorized dealer.

MAINTENANCE AND LUBRICATION

Drive Chain

Always inspect the drive chain before operating the vehicle. Check for damaged or missing o-rings or damaged rollers. Check for correct slack adjustment. Maintain the stone guard-to-rear sprocket clearance at 3 mm. Lubricate the outer surfaces of the roller regularly.

Lubricate the drive chain as outlined in the Lubrication Chart on page 65.

High pressure water may damage components. Do not use high pressure water. See page 99.

Rear Drive Chain Slack

Adjusting or operating the vehicle with improper rear drive chain slack can result in severe damage to the transmission and drive components. Always make sure the slack is within the stated specifications.

Check the amount of chain slack in three different locations by moving the vehicle slightly forward. Measure the chain slack at the tightest of the three positions. At this point the chain should have 4.8-9.5 mm deflection.

Use the following procedure if adjustment is required.

1. Loosen the chain guide.
2. Loosen the two eccentric locking bolts (1).
3. Loosen the caliper mounting bolt located on the left side of the swing arm.
4. Insert a pin punch (2) through the sprocket hub and into the eccentric housing.

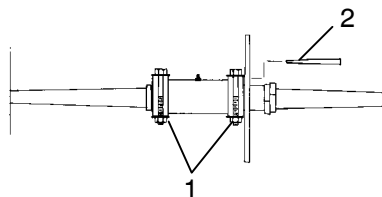
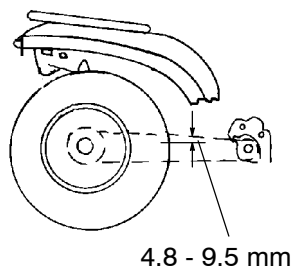

MAINTENANCE AND LUBRICATION

Drive Chain

Rear Drive Chain Slack

5. Roll the vehicle forward or backward to adjust the chain slack to the proper tension. See the illustration for proper splice link clip opening position (1).
6. Tighten the eccentric locking bolts to 61 N-m.
7. Tighten the caliper mounting bolt to 20 N-m.
8. Remove the pin punch.
9. Roll the vehicle forward, checking chain tension in several places around the chain. The chain is adjusted correctly when the tightest portion of the chain has approximately 10 mm deflection.
10. Position the chain guide to allow 3 mm clearance and tighten the retaining bolt to 7 N-m.

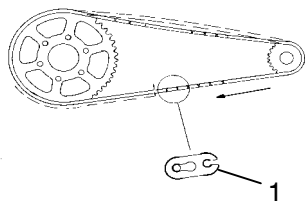

Fuel Filter

Replace the in-line fuel filter at the intervals outlined in the Periodic Maintenance Chart beginning on page 61. Do not attempt to clean the fuel filter.

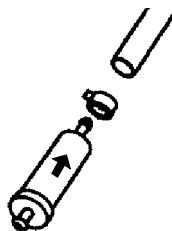

MAINTENANCE AND LUBRICATION

Air Filter

1. Position the vehicle on a level surface.
2. Place the transmission in gear.
3. Lock the mechanical parking brake.

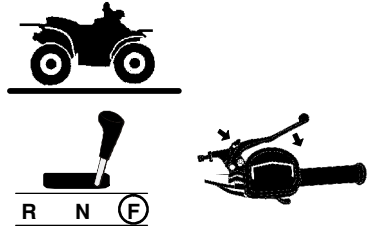

4. Remove the seat.



5. Unlatch the air box clips (1). Remove the air box cover.

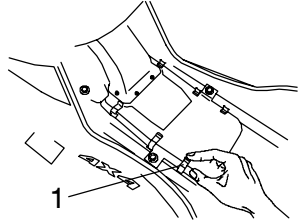

6. Loosen the hose clamp (2) and remove the filter (3).

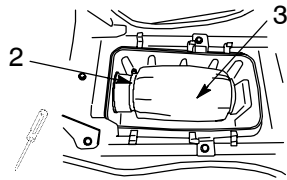

7. Remove the pre-filter (4) from the filter (5). Wash the pre-filter in soapy water. Rinse and air dry.

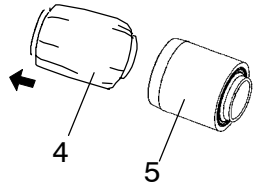

NOTE: Replace the filter if needed.

8. Reverse the steps to reinstall all components.

MAINTENANCE AND LUBRICATION

Lights

WARNING

Poor lighting can result in loss of control or an accident. Lights become dirty during normal operation. Wash the headlights and tail lights frequently.

Hot components can cause serious burns to skin. Do not service the headlamps until they've cooled.

Headlight Replacement

When servicing a halogen lamp, do not touch the lamp with bare fingers. Hold the plastic part (1) of the lamp. Oil from your skin leaves a residue, causing a hot spot that will shorten the life of the lamp.

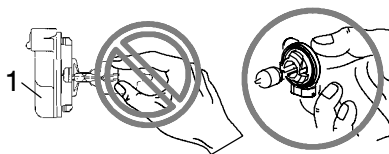

1. Place the transmission in gear.
2. Lock the mechanical parking brake.



3. Turn the back of the headlight counterclockwise.

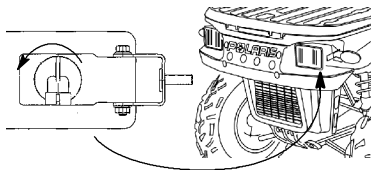

4. Remove the headlamp (2).
5. Apply dielectric grease to the socket.
6. Install the new headlamp.

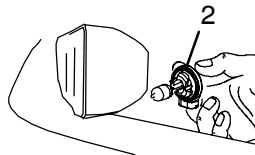

7. Turn the back of the headlight clockwise to reinstall.

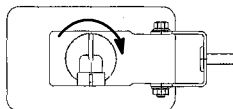

MAINTENANCE AND LUBRICATION

Lights

High Beam Adjustment

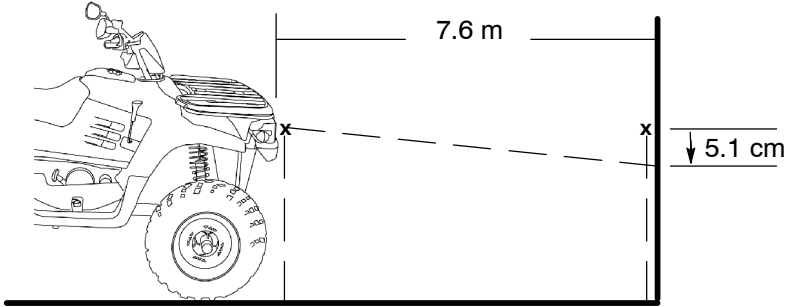

1. Position the vehicle on a level surface. The headlight should be approximately 7.6 meters from a wall.
2. Place the transmission in neutral.
3. Lock the mechanical parking brake.
4. Measure the distance from the floor to the center of the headlight and make a mark on the wall at the same height.

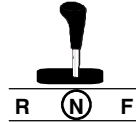

NOTE: Include rider weight on the seat when measuring.

5. Start the engine. Turn the headlight switch to high beam.
6. Observe the headlight aim on the wall. The most intense part of the headlight beam should be aimed 5.1 cm below the mark placed on the wall.
7. Loosen the pivot bolt and adjust the beam.
8. Tighten the bolt.

$$\tau = 3 \text{ N-m}$$

MAINTENANCE AND LUBRICATION

Lights

Taillight/Signal Light Replacement

1. Place the transmission in gear.
2. Lock the mechanical parking brake.

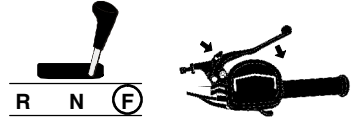

-
3. Rotate the taillight socket counterclockwise to remove it.
 4. Remove the lamp.
 5. Apply dielectric grease to the socket.
 6. Install the new lamp.
 7. Test the lamp for proper operation.
 8. Reinstall all components in reverse order.

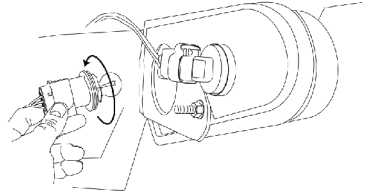

-
9. Rotate the turn signal socket counterclockwise to remove it.
 10. Remove the lamp.
 11. Apply dielectric grease to the socket.
 12. Install the new lamp.
 13. Test the lamp for proper operation..
 14. Reinstall all components in reverse order.

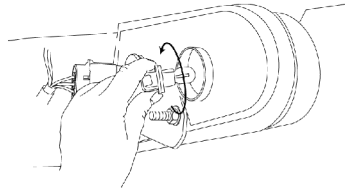

Indicator Lamp Replacement

1. Remove the instrument panel.
2. Using a small, straight-blade screwdriver, turn the base of the bulb 1/4 turn counterclockwise.
3. Remove the lamp. Use a needle-nose plier or similar tool.
4. Install the new lamp. Turn the lamp clockwise 1/4 turn.
5. Reinstall the instrument panel.

MAINTENANCE AND LUBRICATION

Recoil Housing Drain

Always drain the recoil housing (1) after operating the vehicle in wet conditions. Always remove the drain plug before storing the vehicle.

NOTE: Water will enter the recoil housing if the starter handle (2) is disengaged from the rope guide when under water.

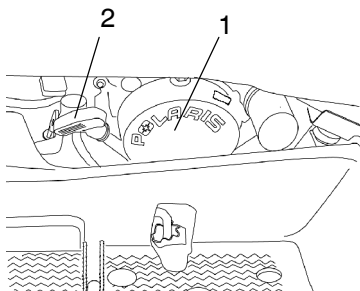

1. Place the transmission in gear.
2. Lock the mechanical parking brake.



3. Using a wrench, remove the drain screw (3) on the bottom of the recoil housing.
4. Reinstall the screw after draining the housing.

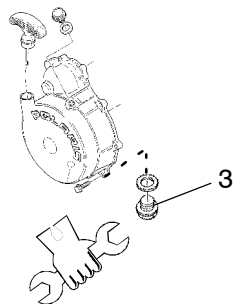

MAINTENANCE AND LUBRICATION

Spark Plugs

1. Remove the left side panel.
See page 80.

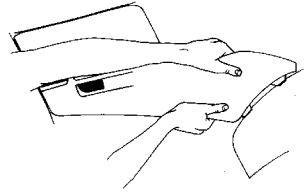

2. Remove the spark plug wire (1). Use the spark plug wrench (2) to remove the spark plug (3). Turn the plug counterclockwise to remove it.

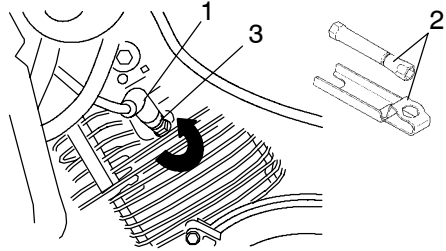

3. Inspect the electrodes for wear and carbon buildup. Replace worn or fouled plugs. Verify that the gap is at specification before installation.

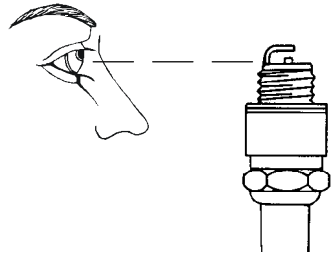

4. Reinstall the spark plug.

$\tau = 19 \text{ N}\cdot\text{m}$

5. Reinstall the spark plug wire.

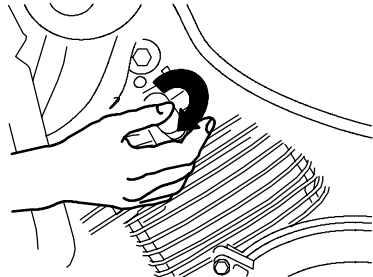

19 N·m

MAINTENANCE AND LUBRICATION

Spark Plugs

Spark Plug Condition

Normal

The insulator tip is tan or brown. There are few combustion deposits. The electrodes are not burned or eroded. This indicates the proper type and heat range for the engine and the service.

NOTE: The tip should not be white. A white insulator tip indicates overheating, caused by use of an improper spark plug or incorrect carburetion adjustments.

Fouled

The insulator tip is black. A damp film covers the firing end. There may be a carbon layer over the entire nose. Generally, the electrodes are not worn. General causes of fouling are excessive oil consumption, improper use of the choke, or incorrect carburetion adjustments.

MAINTENANCE AND LUBRICATION

Vehicle Immersion

CAUTION

If the vehicle stops while fully submerged, major engine damage can result if the machine is not thoroughly inspected. Take the vehicle to your dealer before starting the engine.

If your vehicle has been totally submerged in water and it's impossible to have it serviced before further operation, perform the following procedure.

1. Move the vehicle out of the water.

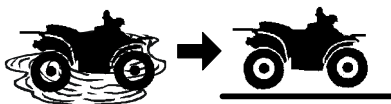

2. Turn the fuel valve off.

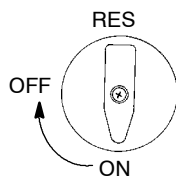

3. Remove the spark plug.
See page 90.

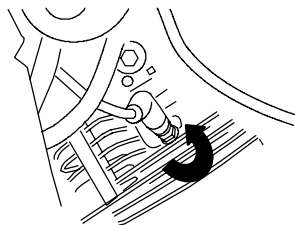

4. Drain any water found in the air box.

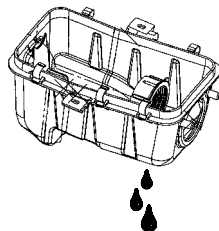

MAINTENANCE AND LUBRICATION

Vehicle Immersion

5. Loosen the carburetor drain screw (1) and drain the carburetor.

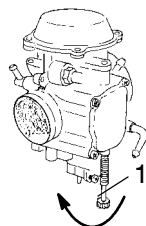

6. Turn the ignition key to the ON position to engage the starter. Engage the starter for only 2-3 seconds.

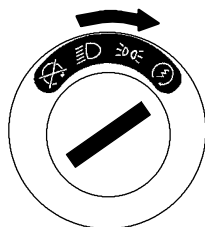

7. Tighten the carburetor drain screw.

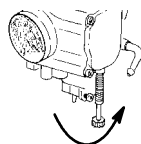

8. Reinstall the spark plug.

$\tau = 19 \text{ N}\cdot\text{m}$

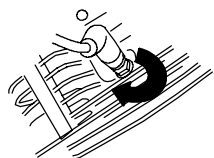

9. Turn the fuel valve on.

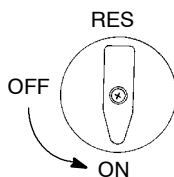

10. Attempt to start the engine. If necessary, repeat the drying procedure.
11. Have the vehicle serviced by your dealer promptly, whether you succeed in starting it or not.

NOTE: If water has been ingested into the PVT, follow the procedure for drying out the PVT. See page 59.

MAINTENANCE AND LUBRICATION

Spark Arrestor

Occasionally, the spark arrestor may accumulate carbon, which can restrict the exhaust if left unattended. Purge the spark arrestor.

WARNING

Allow components to cool sufficiently before servicing. The exhaust system can get extremely hot. Never run the engine in an enclosed area or indoors. Exhaust contains poisonous carbon monoxide gas. Never go under the vehicle while it's inclined.

Remove any combustible materials from the area. Wear eye protection and leather work gloves. Do not stand behind or in front of the vehicle while purging.

1. Remove the arrestor clean-out plug from the bottom of the muffler.

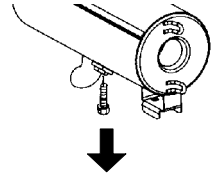

-
2. Place the transmission in neutral.
 3. Lock the mechanical parking brake.



-
4. Start the engine.

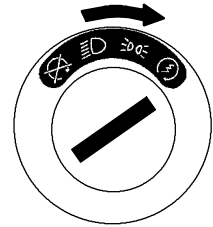

MAINTENANCE AND LUBRICATION

Spark Arrestor

5. Quickly squeeze and release the throttle lever several times to purge carbon from the system.

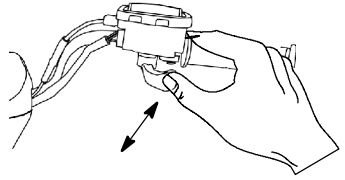

-
6. If carbon comes out of the exhaust, cover or plug the exhaust outlet (1). Wear leather gloves for protection.
 7. Lightly tap on the exhaust pipe with a rubber mallet while repeating step 5.

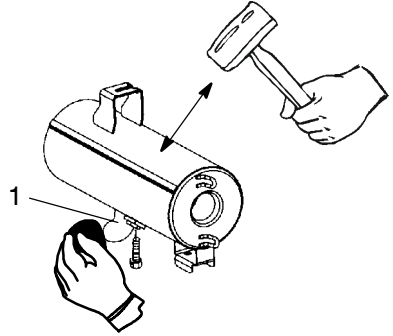

-
8. If particles are still suspected to be in the muffler, elevate the rear of the vehicle 30 cm higher than the front.
 9. Lock the mechanical parking brake.
 10. Block the wheels.

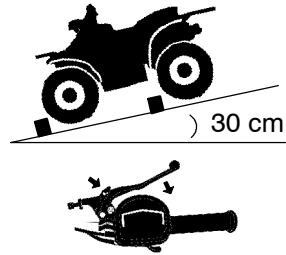

-
11. Repeat steps 5 to 7 until no more particles are expelled.
 12. Turn the engine off. Allow the arrestor to cool.
 13. Reinstall the arrestor plug and remove the exhaust outlet cover or plug.
-

MAINTENANCE AND LUBRICATION

Battery

WARNING

Improperly connecting or disconnecting battery cables can cause sparks which could result in an explosion, causing serious injury or death. When removing the battery, always disconnect the negative (black) cable first. When reinstalling the battery, always connect the negative (black) cable last.

Battery Removal

1. Place the transmission in gear.
2. Lock the mechanical parking brake.

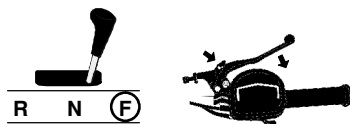

3. Disconnect the battery hold-down strap. Remove the battery cover.
4. Disconnect the black negative (-) cable first.
5. Disconnect the red positive (+) cable last.
6. Lift and remove the battery.

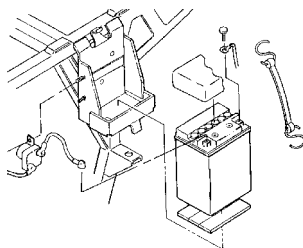
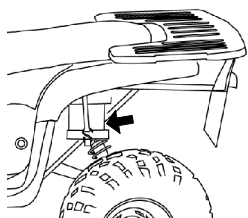

Battery Installation

Always install a fully charged battery. See page 97.

1. Place the battery in the battery holder.
2. Verify that cables are routed properly.
3. Connect the red positive (+) cable first.
4. Connect the black negative (-) cable last.
5. Install the battery cover.
6. Attach the hold-down strap.

MAINTENANCE AND LUBRICATION

Battery

Battery Storage

Whenever the vehicle is not used for a period of three months or more, remove the battery from the vehicle. Verify that it's fully charged, and store it out of the sun in a cool, dry place. Check battery voltage each month during storage and recharge as needed to maintain a full charge.

NOTE: Battery charge can be maintained by using a Polaris Battery Tender™ charger (P/N 2871076) or by charging about once a month to make up for normal self-discharge. Battery Tender™ can be left connected during the storage period, and will automatically charge the battery if the voltage drops below a pre-determined point.

Battery Charging

The following battery charging instructions apply only to the installation of an activated, sealed battery. Read all instructions before proceeding with the installation of this battery.

A sealed battery is already filled with electrolyte. It has been sealed and *is fully charged* at the factory. Always keep a sealed battery fully charged.

- **DO NOT** pry the sealing strip off.
- **DO NOT** add any other fluid to this battery.
- A fully charged battery will register 12.8 V or higher.

1. Check battery voltage with a voltmeter or multimeter.
2. If voltage is low, recharge the battery at 1.2 amps or less until the voltage is 12.8 or greater.

NOTE: When using an *automatic* charger, refer to the charger manufacturer's instructions for recharging. When using a *constant current* charger, follow the guidelines on page 98.

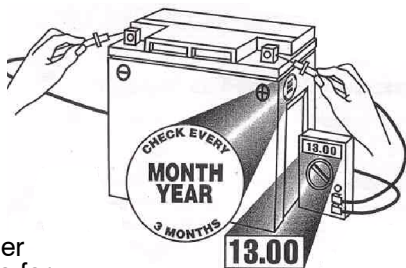

MAINTENANCE AND LUBRICATION

Battery

Battery Charging Chart (Constant Current Charger)

State of Charge	Voltage	Action	Charge Time* (Using constant current charger @ standard amps specified on top of battery)
100%	12.8-13.0 volts	None, check at 3 mos. from date of manufacture	None required
75%-100%	12.5-12.8 volts	May need slight charge, if no charge given, check in 3 months	3-6 hours
50%-75%	12.0-12.5 volts	Needs Charge	5-11 hours
25%-50%	11.5-12.0 volts	Needs Charge	At least 13 hours, verify state of charge
0%-25%	11.5 volts or less	Needs Charge	At least 20 hours

NOTE: Always verify battery condition before and one to two hours after charging.

WARNING

An overheated battery may explode, causing serious injury or death. Always watch charging times carefully. Stop charging if the battery becomes very warm to the touch. Allow it to cool before resuming charging.

MAINTENANCE AND LUBRICATION

Cleaning the Vehicle

Keeping the vehicle clean will extend the life of components.

- Use a garden hose and a pail of mild soap and water
- Use a professional-type washing mitten, cleaning the upper body first and the lower parts last.
- Rinse with clean water frequently.
- Wipe the vehicle dry with a chamois.
- Do not use high pressure water.

High pressure water may damage components. If a high pressure wash system must be used, exercise extreme care to avoid directing water onto the wheel bearings, transmission seals, body panels, brakes and warning labels. Grease all fittings immediately after washing, and allow the vehicle to run for a while to evaporate any water that may have entered the engine or exhaust system.

NOTE: If *warning and safety* labels are damaged, contact your Polaris dealer for free replacements.

Waxing the Vehicle

Wax the vehicle with any non-abrasive automotive paste wax. Avoid harsh cleaners since they can scratch the finish.

CAUTION

Some products, including insect repellants and chemicals, will damage plastic surfaces. Use caution when using these products near plastic surfaces.

MAINTENANCE AND LUBRICATION

Storing the Vehicle

See page 103 for the part numbers of Polaris products.

Clean the Vehicle

See page 99.

Stabilize the Fuel

1. Fill the fuel tank.
2. Add Polaris Carbon Clean Fuel Treatment or Polaris Fuel Stabilizer. Follow the instructions on the container. (Carbon Clean Plus will reduce the possibility of bacterial growth in the fuel system.) Allow 15-20 minutes of operation for the stabilizer to disperse through the fuel in the tank and carburetor.
3. Turn the fuel valve off.
4. Drain the carburetor bowl.

Change Oil and Filter

Change the oil and filter. See page 68.

Air Filter / Air Box

Inspect and clean (or replace) the pre-cleaner and air filter. Clean the air box and drain the sediment tube. See page 85.

Check / Change Fluids

Inspect fluid levels and change fluids if necessary.

- Transmission oil
- Engine oil
- Brake fluid

Drain the Recoil Housing

See page 89.

Battery Storage

Remove the battery. Make sure that it's fully charged. See page 97.

MAINTENANCE AND LUBRICATION

Storing the Vehicle

Engine Fogging

Use Polaris Engine Fogging Oil. Follow label directions carefully.

CAUTION

Starting the engine during the storage period will disturb the protective oil film, which can lead to engine damage. Never start the engine during the storage period.

Storage Area / Cover

1. Make sure tire pressure is at specification.
2. Using suitable supports under the frame, raise the vehicle slightly so that the tires are not touching the ground.
3. Be sure the storage area is well ventilated.
4. Cover the machine with an appropriate cover. Do not use plastic or coated materials, as they do not allow proper ventilation to prevent condensation, corrosion and oxidation.

Accessories

Auxiliary power outlets provide 12V power for operating accessories such as hand held spot lights. See your Polaris dealer for more information about accessories.

MAINTENANCE AND LUBRICATION

Transporting the Vehicle

Follow these procedures when transporting the vehicle.

1. Turn the engine off.
Remove the key to prevent loss during transporting.

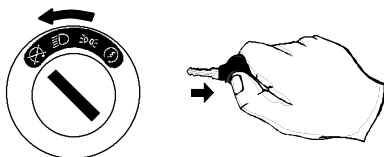

2. Place the transmission in gear.

3. Lock the mechanical parking brake.



4. Turn the fuel valve off.

5. Be sure the fuel cap, oil cap and seat are installed correctly.

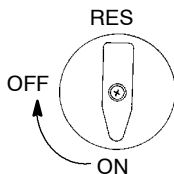

6. Attach the *FRAME* of the Quadricycle to the transporting unit securely using suitable straps or rope.

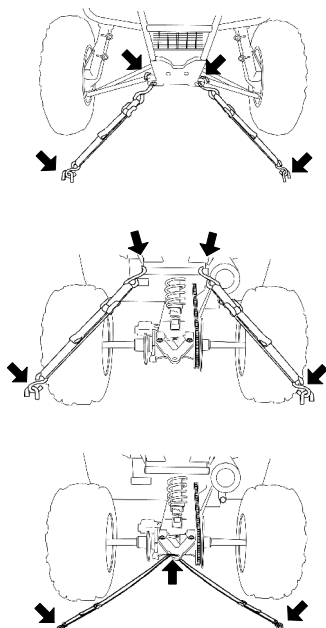

POLARIS PRODUCTS

Part No.	Description
Engine Lubricant	
2870791	Fogging Oil (355 ml Aerosol)
2871281	Premium 4 Synthetic 0W-40 (4-Cycle) Engine Oil (.95 l)
2871844	Premium 4 Synthetic 0W-40 (4-Cycle) Engine Oil (3.8 l)
Gearcase / Transmission Lubricants	
2873602	Premium AGL Synthetic Gearcase Lube (.95 l)
2873603	Premium AGL Synthetic Gearcase Lube (3.8 l)
2871653	Premium ATV Angle Drive Fluid (237 ml)
2872276	Premium ATV Angle Drive Fluid (.95 l)
2870465	Pump for 3.8 liter jug
2871654	Premium Demand Drive Hub Fluid (237 ml)
2872277	Premium Demand Drive Hub Fluid (9.5 l)
Grease / Specialized Lubricants	
2871322	Premium All Season Grease (89 ml cartridge)
2871423	Premium All Season Grease (414 ml cartridge)
2871460	Starter Drive Grease
2871515	Premium U-Joint Lube (89 ml)
2871551	Premium U-Joint Lube (414 ml)
2871312	Grease Gun Kit
2871329	Dielectric Grease (Nyogel™)
2872073	Chain Lube (185 ml aerosol)
2872348	Chain Lube (473 ml aerosol)
Additives / Miscellaneous	
2872889	Brake and Clutch Cleaner
2871326	Carbon Clean Plus (355 ml)
2870652	Fuel Stabilizer (473 ml)
2870990	DOT3 Brake Fluid
2872893	Engine Degreaser
2871956	LOCTITE 565 Thread Sealant

TROUBLESHOOTING

Drive Belt and Cover Problems	
Possible Cause	Solution
Driving the vehicle onto a pickup or tall trailer.	Avoid stopping on the ramp or creeping slowly up the ramp.
Starting out going up a steep incline.	Perform the K-turn as described on page 32.
Driving at low RPM or low ground speed (at approximately 3-7 MPH).	Drive at a slightly higher speed. Avoid creeping.
Insufficient warm-up of vehicles exposed to low ambient temperatures.	Warm the engine at least 5 minutes. Place the transmission in neutral. Lock the parking brake. Advance the throttle to about 1/8 throttle in short bursts, 5 to 7 times. The belt will become more flexible and prevent belt burning.
Slow and easy clutch engagement.	Use the throttle quickly and effectively for efficient engagement.
Towing/pushing at low RPM/low ground speed.	Install a one tooth smaller counter shaft sprocket.
Stuck in mud or snow.	Carefully use fast, aggressive throttle application to engage clutch. WARNING: Excessive throttle may cause loss of control and vehicle overturn.
Climbing over large objects from a stopped position.	Carefully use fast, brief, aggressive throttle application to engage clutch. WARNING: Excessive throttle may cause loss of control and vehicle overturn.
Belt slippage from water or snow ingestion into the PVT system.	Dry out the PVT as outlined on page 59. Inspect clutch seals for damage if repeated leaking occurs.
Clutch malfunction.	Contact your Polaris dealer for inspection of clutch components.
Poor engine performance.	Check for fouled plugs or foreign material in gas tank, fuel lines, or carburetor. Contact your dealer for service.

TROUBLESHOOTING

Contact your Polaris dealer for service if you're unable to identify solutions using the following charts.

Engine Does Not Rotate	
Possible Cause	Solution
Blown fuse	Replace fuse
Low battery voltage	Recharge battery to 12.5 VDC
Loose battery connections	Check all connections and tighten
Loose solenoid / starter connections	Check all connections and tighten

Engine Rotates, Fails to Start	
Possible Cause	Solution
Out of fuel	Turn fuel valve to reserve, refuel
Clogged fuel valve or filter	Inspect and clean or replace
Water is present in fuel	Drain the fuel system and refuel
Fuel valve is turned off	Turn the fuel valve on
Old or non-recommended fuel	Replace with new fuel
Fouled or defective spark plug(s)	Inspect plug(s), replace if necessary
No spark to spark plug	Inspect plug(s), verify stop switch is on
Crankcase filled with water or fuel	Immediately see your Polaris dealer
Overuse of choke	Inspect, clean and/or replace spark plugs
Clogged fuel filter	Replace the filter
Low battery voltage	Recharge battery to 12.5 VDC
Mechanical failure	See your Polaris dealer

Engine Pings or Knocks	
Possible Cause	Solution
Poor quality or low octane fuel	Replace with recommended fuel
Incorrect ignition timing	See your Polaris dealer
Incorrect spark plug gap or heat range	Set gap to specs or replace plugs

TROUBLESHOOTING

Engine Backfires	
Possible Cause	Solution
Weak spark from spark plugs	Inspect, clean and/or replace spark plugs
Incorrect spark plug gap or heat range	Set gap to specs or replace plugs
Old or non-recommended fuel	Replace with new fuel
Incorrectly installed spark plug wires	See your Polaris dealer
Incorrect ignition timing	See your Polaris dealer
Mechanical failure	See your Polaris dealer

Engine Runs Irregularly, Stalls or Misfires	
Possible Cause	Solution
Fouled or defective spark plugs	Inspect, clean and/or replace spark plugs
Worn or defective spark plug wires	See your Polaris dealer
Incorrect spark plug gap or heat range	Set gap to specs or replace plugs
Loose ignition connections	Check all connections and tighten
Water present in fuel	Replace with new fuel
Low battery voltage	Recharge battery to 12.5 VDC
Kinked or plugged fuel vent line	Inspect and replace
Incorrect fuel	Replace with recommended fuel
Clogged air filter	Inspect and clean or replace
Reverse speed limiter malfunction	See your Polaris dealer
Electronic throttle control malfunction	See your Polaris dealer
Other mechanical failure	See your Polaris dealer
Possible Lean Fuel Mixture Cause	Solution
Low or contaminated fuel	Add or change fuel, clean the fuel system
Low octane fuel	Replace with recommended fuel
Clogged fuel filter	Replace filter
Incorrect jetting	See your Polaris dealer
Possible Rich Fuel Mixture Cause	Solution
Overuse of choke	Inspect, clean and/or replace spark plugs
Fuel is very high octane	Replace with lower octane fuel
Incorrect jetting	See your Polaris dealer

TROUBLESHOOTING

Engine Stops or Loses Power

Possible Cause	Solution
Out of fuel	Turn fuel valve to reserve, refuel
Kinked or plugged fuel vent line	Inspect and replace
Water present in fuel / old fuel	Replace with new fuel
Overuse of choke	Inspect, clean and/or replace spark plugs
Fouled or defective spark plugs	Inspect, clean and/or replace spark plugs
Worn or defective spark plug wires	See your Polaris dealer
Incorrect spark plug gap or heat range	Set gap to specs or replace plugs
Loose ignition connections	Check all connections and tighten
Low battery voltage	Recharge battery / Check charging system
Incorrect fuel	Replace with recommended fuel
Clogged air filter	Inspect, clean or replace
Reverse speed limiter malfunction	See your Polaris dealer
Electronic throttle control malfunction	See your Polaris dealer
Other mechanical failure	See your Polaris dealer
Overheated engine	Clean radiator screen and core if equipped Clean engine exterior See your Polaris dealer

SPECIFICATIONS

2005 Trail Boss 330 Quadricycle

<i>Capacities</i>	
Body Style	Gen IV
Gross Vehicle Weight	438 kg
Fuel Capacity	12.35 l
Transmission Oil	335 ml
Engine Oil Capacity	1.8 l (incl. oil cooler) 1.6 l (oil change only)
Front Rack	34.1 kg
Rear Rack	56.7 kg
Tongue Weight	38.6 kg
Towing Rating	386 kg
Unbraked Trailer Towing Capacity*	573 kg
Turn Radius	190.5 cm
Ground Clearance	14 cm
Height	116.8 cm
Length	190.5 cm
Width	116.8 cm
Seat Height	86.4 cm
Dry Weight	229 kg
Wheel Base	125.7 cm
<i>Engine & Cooling</i>	
Engine Model Number / Type	ES-32PFE-103 / 4 Cycle, Single Cylinder
Lubrication	Wet Sump
Bore x Stroke	78.5 x 68
Displacement	329
Compression Ratio	9.2/1
Engine Cooling	Air with fan assisted oil cooler
Alternator Output (watts)	200w @5000 rpm
Carburetion	BST34
Main Jet	120
Pilot Jet	42.5
Needle Jet	P-0M (829)
Pilot Air Jet	160
Pilot Screw	2 3/16 turns
Jet Needle	4HB48-3
Ignition	DC CDI
Timing	24° ± 2° @ 5000 RPM
Spark Plug Type / Gap	BKR6E / .9 mm

* Based on EU Directive 76/432/EC

SPECIFICATIONS

2005 Trail Boss 330 Quadricycle

<i>Drive System</i>	
Drive System Type	PVT
Shift Type	Side Lever (F/N/R)
Gear Reduction - Reverse	3.05/1
Gear Reduction - Forward	2.68/1
Final Drive (ratio)	11/40 78P
Drive Chain	520 O-Ring
Front Tires	23 x 7-10 (34.5 KPa)
Rear Tires	22 x 12-10 (34.5 KPa)
<i>Suspension and Brakes</i>	
Front Suspension: Mac Strut	17 cm travel
Rear Suspension: Progressive Rate Swing Arm	22.9 cm travel
Shock Adjustment	CAM
Brake System	Hydraulic disc front and rear, fixed disc, hydraulic floating caliper
Hand Brake	Hydraulic, left-hand apply, rear caliper only, equipped w/temporary hydraulic lock
Foot Brake	Hydraulic, single apply, all-wheel
Parking Brake	Right-hand apply w/mechanical lock, floating caliper system, disc brake
<i>Features</i>	
Headlight	2 Hi/Lo 60w/55w
Taillight	2x8.26w
Brake Light	2x26.9w
Battery	12V 14 AH
Instrument Cluster	LCD
Electric Start	Standard
High Beam Indicator	Standard
High Temp Indicator	Standard
Neutral Indicator	Standard
Reverse Indicator	Standard
Tool Kit	Standard

SPECIFICATIONS

2005 Trail Boss 330 Quadricycle

Jetting Chart

Altitude	AMBIENT TEMPERATURE	Below 5° C	+5°C and above
Meters	0-1800	127.5	122.5
	1800-3700	120	115

Clutching Chart

Altitude		Shift Weight	Drive Clutch Spring	Driven Clutch Spring	Helix/Spring Setting
Meters	0-1800	10RH 5630709	Blue/Green 7041157	Black 7041782	40 5131446 2+2
	1800-3700	20-40 5631356	Blue/Green 7041157	Black 7041782	40 5131446 2+2

WARRANTY

LIMITED WARRANTY

Polaris Industries Inc., 2100 Highway 55, Medina, MN 55340, gives a TWO YEAR LIMITED WARRANTY on all components of the Polaris Quadricycle against defects in material or workmanship. This warranty covers the parts and labor charges for repair or replacement of defective parts which are covered by this warranty. This warranty begins on the date of purchase. This warranty is transferrable to another consumer during the warranty period through a Polaris dealer.

REGISTRATION

At the time of sale, the Warranty Registration Form must be completed by your dealer and submitted to Polaris within ten days. Upon receipt of this registration, Polaris will record the registration for warranty. **THE PURCHASER MUST COMPLETE A QUADRICYCLE SAFETY TRAINING COURSE PROVIDED BY THE DEALER IN ORDER TO HAVE VALID WARRANTY ON THE QUADRICYCLE.** No verification of registration will be sent to the purchaser as the copy of the Warranty Registration Form will be the warranty entitlement. If you have not signed the original registration and received the “customer copy”, please contact your dealer immediately. **NO WARRANTY COVERAGE WILL BE ALLOWED UNLESS YOUR QUADRICYCLE IS REGISTERED WITH POLARIS.**

Initial dealer preparation and set-up of your vehicle is very important in ensuring trouble-free operation. Purchasing a machine in the crate or without proper dealer set-up will void your warranty coverage.

LIMITATIONS OF WARRANTIES AND REMEDIES

The Polaris limited warranty excludes any failures that are not caused by a defect in material or workmanship. This warranty does not cover accidental damage, normal wear and tear, abuse or improper handling. This warranty also does not cover any Quadricycle that has been altered structurally, modified, neglected, improperly maintained, used for racing, or used for purposes other than for which it was manufactured, or for any damages which occur during trailer transit or as a result of unauthorized service or the use of unauthorized parts. In addition, this warranty does not cover physical damage to paint or finish, stress cracks, tearing or puncturing of upholstery material, corrosion, or defects in parts, components or the vehicle due to fire, explosions or any other cause beyond Polaris' control.

This warranty does not cover the use of unauthorized lubricants, chemicals, or fuels that are not compatible with the Quadricycle. The exclusive remedy for breach of this warranty shall be, at Polaris' exclusive option, repair or replacement of any defective materials, or components or products. **THE REMEDIES SET FORTH IN THIS WARRANTY ARE THE ONLY REMEDIES AVAILABLE TO ANY PERSON FOR BREACH OF THIS WARRANTY. POLARIS SHALL HAVE NO LIABILITY TO ANY PERSON FOR INCIDENTAL, CONSEQUENTIAL OR SPECIAL DAMAGES OF ANY DESCRIPTION, WHETHER ARISING OUT OF EXPRESS OR IMPLIED WARRANTY OR ANY OTHER CONTRACT, NEGLIGENCE, OR OTHER TORT OR OTHERWISE.** Some states do not permit the exclusion or limitation of incidental or consequential damages or implied warranties, so the above limitations or exclusions may not apply to you if inconsistent with controlling state law.

WARRANTY

LIMITATIONS OF WARRANTIES AND REMEDIES

ALL IMPLIED WARRANTIES (INCLUDING BUT NOT LIMITED TO THE IMPLIED WARRANTIES OF MERCHANTABILITY AND FITNESS FOR A PARTICULAR PURPOSE) ARE LIMITED IN DURATION TO THE ABOVE TWO YEAR WARRANTY PERIOD. POLARIS FURTHER DISCLAIMS ALL EXPRESS WARRANTIES NOT STATED IN THIS WARRANTY. Some states do not allow limitations on how long an implied warranty lasts, so the above limitation may not apply to you if inconsistent with controlling state law.

HOW TO OBTAIN WARRANTY SERVICE

If your Quadricycle requires warranty service, you must take it to a Polaris dealer authorized to repair Polaris Quadricycles. When requesting warranty service you must present your copy of the Warranty Registration form to the dealer. (THE COST OF TRANSPORTATION TO AND FROM THE DEALER IS YOUR RESPONSIBILITY). Polaris suggests that you use your original selling dealer; however, you may use any Polaris Servicing Dealer to perform warranty service.

Please work with your dealer to resolve any warranty issues. Should your dealer require any additional assistance they will contact the appropriate personnel at Polaris.

This warranty gives you specific legal rights, and you may also have other rights which vary from state to state.

If any of the above terms are void because of state or federal law, all other warranty terms will remain in effect.

MAINTENANCE RECORD

DATE	MILES/KM	TECHNICIAN	SERVICE PERFORMED / COMMENTS

MAINTENANCE RECORD

DATE	MILES/KM	TECHNICIAN	SERVICE PERFORMED / COMMENTS

MAINTENANCE RECORD

DATE	MILES/KM	TECHNICIAN	SERVICE PERFORMED / COMMENTS

INDEX

A

Accessories 101
Age Restriction 7
Air Filter 85

B

Battery 96-98
Battery Charging 97-98
Battery Installation 96
Battery Removal 96
Battery Storage 97, 100
Brake Fluid 75
Brake Lever, Parking 43, 45
Brake Lever, Rear 43-44
Brake, Foot 44
Brakes 44-45, 74-75
Break-In Period 55

C

Carburetor 78
Cleaning the Vehicle 99
Clutching Chart 110
Controls 40-43
Cooler Maintenance 71
Crankcase Emission Control System 60

D

Diagnostic Mode 53-54
Drive Chain 83-84
Driving Downhill 28
Driving in Reverse 36
Driving on Slippery Surfaces 26
Driving Over Obstacles 27
Driving Procedures 24
Driving Safely 24-39
Driving Through Water 34-35
Driving Uphill 30-31

E

Electromagnetic Interference 60
Electronic Throttle Control 42
EMISSION CONTROL SYSTEMS 60
Engine Fogging 101
Engine Stop Switch 41
Equipment Modifications 8
ETC 42
Exhaust Emission Control System 60
Eye Protection 23

F

FEATURES AND CONTROLS 40-54
Foot Brake 44
Fuel Filter 84
Fuel Stabilizer 100
Fuel Tank 47
Fuel Valve 47

G

Gear Selector 48

H

Handlebar Adjustment 77
Hauling Cargo 38-39
Hazard Warning Switch 43
Headlights 86
Helmet 23
High Beam Adjustment 87
Horn 42
Hour Meter 52

I

Immersion 92-93
Indicator Lamp Replacement 88
Instrument Cluster 50-54
Instruments 40-43

J

Jetting Chart 110

K

K-Turn 32

L

Light Switch 41
Lights 86-88
Lubrication Recommendations 65

M

Main Switch 40
MAINTENANCE AND
LUBRICATION 61-102
Maintenance Chart Key 61
MAINTENANCE RECORD 113-115
Making Turns 25
Master Cylinder (Foot Brake) 75
Master Cylinder (Handlebar) 75
Mirrors 43

INDEX

N

Noise Emission Control System 60

O

Odometer 52
Oil Change 68-70
Oil Check 67
Oil Cooler 71
Oil Filter Change 68-70
Oil . Engine 66
OPERATION 55-59
Operator Safety 6-17
Override Switch 40

P

Parking Brake (Hydraulic) 45
Parking Brake (Mechanical) 45
Parking on an Incline 37
Periodic Maintenance Chart 61-64
POLARIS PRODUCTS 103
Pre Ride Inspection 56
PVT Drying 59
PVT System 59

R

Rear Drive Chain Slack 83-84
Rear Springs 76
Recoil Housing 89
Recoil Starter 43, 49
Restrictions 8
Rider Information Center 51-54
Riding Gear 23

S

Safe Riding Gear 23
SAFETY 6-39
Safety Decals and Locations 18-22
Safety Training 7
Severe Use 61
Side Panel Removal 80
Sidehilling 29
Signal Light 88
Spark Arrestor 60, 94-95
Spark Plugs 90-91

S

SPECIFICATIONS 108-110
Speedometer Mode Switch 40
Springs, Rear 76
Starting the Engine 57-58
Steering 76
Steering Assembly 77
Steering Lock 46
Stop Switch 41
Storing the Vehicle 100-101
Suspension 76
Symbol Identification 65

T

TABLE OF CONTENTS 3
Tachometer 52
Taillight 88
Throttle Cable Freeplay 79
Throttle lever 41
Tire Tread Depth 82
Tires 82
Toe Alignment 76
Torque Symbol 65
Towing 38-39
Transmission 59
Transmission Oil Change 73
Transmission Oil Check 72
Transporting the Vehicle 102
Trip Meter 52
TROUBLESHOOTING 104-107
Turn Indicator 43
Turning Around on a Hill 32-33

V

VEHICLE IDENTIFICATION
NUMBERS 5
Vehicle Immersion 92-93

W

Warranty 111-112
Waxing the Vehicle 99
Wheel Hub Tightening 82
Wheel Installation 81
Wheel Removal 81