

Vacuum Solutions

Application Support

Service



LEYBOLD VACUUM

GA 05.130/3.02



SERVICE OF VACUUM PUMP SYSTEMS
2442 Emrick Blvd. Bethlehem, PA 18020
For Service Call (610) 625-1505
www.polvac.com



MAG 1600 C, CT
MAG W 1600 C, CT
MAG 2000 C, CT
MAG W 2000 C, CT

Turbomolecular Pump
with Magnetic Bearing

MAG.DRIVE L, L2

Electronic Frequency
Converter

Software version
MAG.DRIVE L: 1.2.3
MAG.DRIVE L2: 1.3.4 - 1.3.7

Cat. Nos.
894 14 /28
894 15 /29
894 16 /30
894 17 /31
857 24 /23

Operating Instructions

Contents	Page
1 Description	3
1.1 System overview	3
1.2 Compatibility with pumped media	4
1.3 Design of the MAG	4
1.4 Function and design of the MAG.DRIVE	6
1.5 Standard specification	8
1.6 Technical data	9
1.7 Ordering information	10
2 Installation	22
2.1 General safety information	22
2.2 Unpacking - storing - transportation	22
2.3 Operating environment	23
2.4 Connecting the MAG to the vacuum chamber	23
2.5 Connecting the backing pump	28
2.6 Connecting the cooling water	28
2.7 Connecting the purge gas	30
2.8 Installing the MAG.DRIVE	32
2.8.1 Power supply connection X10	33
2.8.2 Pump connection	33
2.8.3 Control plug X1	36
2.8.4 Interface connector	38
2.8.5 Connection X33	39
3 Operation	40
3.1 Switching on	40
3.2 Operation	41
3.3 Switching off	41
4 Converter Control	43
4.1 Functions of the front panel keys	43
4.2 Operating display	43
4.3 Remote control	44
4.4 Operating statuses	46
4.5 Operating menu for the MAG.DRIVE L	48
4.5.1 Basic menu	48
4.5.2 Settings converter	49
4.5.3 Settings pump	50
4.5.4 Settings active magnetic bearing	50
4.5.5 Settings temperature management system	51
4.5.6 Settings purge / vent	51
4.5.7 Total view of the menu	52
4.6 Operating menu for the MAG.DRIVE L2	53
4.6.1 Basic menu	53
4.6.2 Settings converter	54
4.6.3 Settings pump	55
4.6.4 Settings temperature management system	55
4.6.5 Settings purge / vent	56
4.6.6 Total view of the menu	57
4.7 Temperature management system	58
4.7.1 TMS for the MAG.DRIVE L	58
4.7.2 TMS for the MAG.DRIVE L2	60
5 Maintenance	62
5.1 Removing the pump from the system	62
5.2 Service at Leybold's	64

6 Troubleshooting	65
6.1 Troubleshooting for the MAG.DRIVE L	66
6.1.1 Warning and failure messages	66
6.1.2 Failure messages	67
6.1.3 Warning messages	68
6.1.4 Malfunctions	69
6.2 Troubleshooting for the MAG.DRIVE L2	70
6.2.1 Warning messages	70
6.2.2 Failure messages	72
6.2.3 Malfunctions	77
Certifications	78
Forms	81

Figures

The references to diagrams, e. g. (1/2) consist of the Fig. No. and the Item No. in that order.

We reserve the right to alter the design or any data given in these Operating Instructions. The illustrations are not binding.

The Operating Instructions are included with the pump **and** the converter. If they have different editions, the version delivered with the pump describes the pump correctly and the version delivered with the converter describes the converter correctly. The version number is the digit behind the „/“ in the GA No.. Example: GA 05.130/1.02 is the first edition.

Differences between the versions:

/1 → /2

- We added the operation diagram and the pumping speed curve for the MAG W 1600.
- We corrected some minor text mistakes.

/2 → /3

- We separated the Troubleshooting for the MAG.DRIVE L & L2 and made it more detailed for the MAG.DRIVE L2.
- We added technical data, the dimensional drawing, the operation diagram, and the pumping speed curve for the MAG 1600.
- We added ordering data.
- We added an installation instruction for the splinter guard.
- We corrected some minor text mistakes.

Thus, you may use version /3 instead of versions /1 and /2 for the pump **and** the converter.

If you have a MAG pump with a MAG.DRIVE 2000 converter you must use the Operating Instructions delivered with the converter for the operation of the converter.

1 Description

1.1 System overview

The Leybold **MAG** pumping system consists of:

- The **MAG W 1600, MAG 2000, or MAG W 2000** turbopump

The **MAG** are turbomolecular pumps utilizing magnetic bearings. They are designed to evacuate vacuum chambers down to pressure values in the high-vacuum range and to pump high gas throughputs.

The **C versions** are equipped with a purge gas valve and a Pt 100 temperature sensor for the cooling water temperature.

The **CT versions** are additionally equipped with a temperature management system (TMS) to control the base flange temperature.

The pumps are available with 2 different rotors:

MAG version: 11 turbo pump stages

MAG W version: 6 turbo pump stages and 1 drag stage.

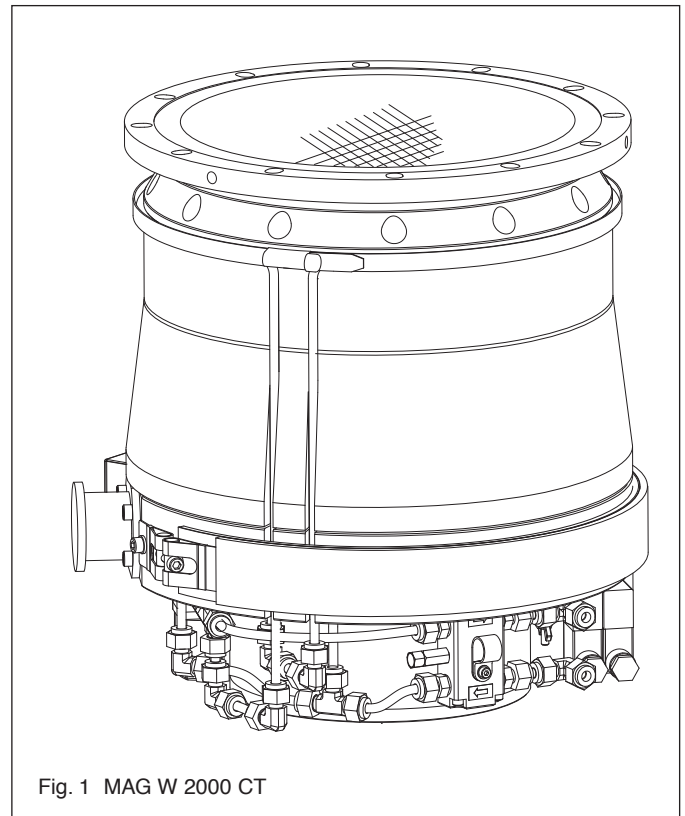

Fig. 1 MAG W 2000 CT

- The **MAG.DRIVE L or MAG.DRIVE L2** frequency converter

The electronic converter converts the single-phase line supply voltage into a three-phase DC voltage to drive the pump motor. It also evaluates measured signals and controls

- the pump functions
- the temperature management system (TMS) and
- the active magnetic bearing system

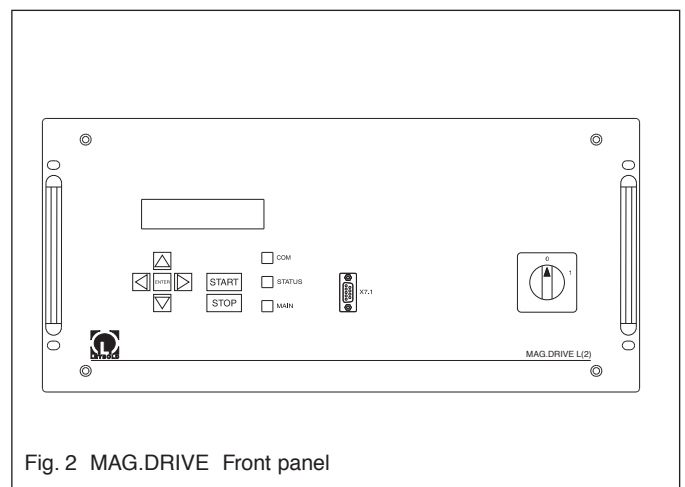

Fig. 2 MAG.DRIVE Front panel

- A **cable set** consisting of:
 - BEARING cable
 - TMS cable
 - DRIVE cable

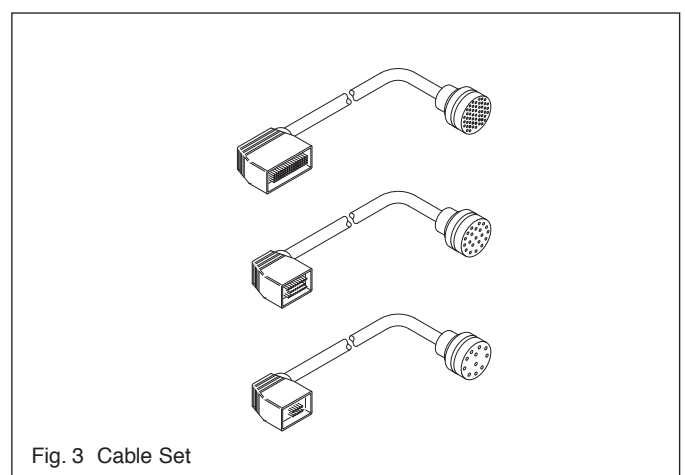

Fig. 3 Cable Set

1.2 Compatibility with pumped media

The MAG (W) 1600/2000 C/CT are specifically designed for the needs of the semiconductor industry.

Corrosion protection

To protect the pump from corrosive gases it is mandatory to use dry Nitrogen purge during operation of the pump. The purge gas protects the bearing section and the motor from corrosive gases.

The rotor and the stator of the pump are KEPLA-coated to prevent corrosive attack caused by the process gases. The corrosion protection of the pump is effective only when the pump is protected from moisture during standstill and storage. If the process gas contains moisture, contact Leybold for recommendations.

Sublimation

Some media (e.g. AlCl_3) can sublime in the pump and form deposits. Thick coatings can infringe on the required operating clearance and ultimately cause the pump to seize. These deposits can also react with moisture and generate corrosive gases (e.g. HCl). This can become very critical when the pump is exposed to air. Deposits can be avoided in many processes by heating the pump with TMS (Temperature Management System).

The TMS is integrated in all CT-versions. The purpose of the TMS is to keep the baseflange temperature in a constant range. To achieve the temperature the pump is equipped with a heaterband.

Some media (e.g. metall organic compounds) can decompose at the hot surface of the pump and build layers. Please direct any inquiries to the manufacturer.

Ignition danger

During operation the pressure inside the MAG is so low that there is no danger of ignition (at pressures below about 100 mbar). A hazardous condition will be created if flammable mixtures enter the hot pump at pressures above 100 mbar. During operation the pump can reach temperatures as high as 120°C (248°F). If the pump is damaged, sparks could occur which could ignite explosive mixtures.

Please consult us regarding the media which can safely be handled with this unit, with or without purge gas.

1.3 Design of the MAG

The MAG comprises basically the pump housing, the multistage rotor with the stator package, the drive, and a magnetic bearing.

Rotor

The rotor is made from a high strength aluminium alloy. The rotor and the lower stator plates are protected with a special ceramic layer (KEPLA-coat). The standard rotor is a multi-stage axial-flow turbine. In addition to the turbine stage the wide range rotor has a screw stage.

Both rotors are machined from one piece and the geometry of the the blades is optimized for high compression and pumping speed of the typical gases used in semiconductor manufacturing processes (e.g. SF_6 , Ar, BCl_3).

Bearings

The MAG 1600/2000 has a built-in precision 5-axis controlled magnetic bearing. The rotor is suspended by trouble-free magnets:

- along two orthogonal axes in each of two radial planes
- and completely in the axial direction

The bearing concept allows for low vibration operations and insures operation of the pump in any mounting position. Magnetic bearings also guarantee ultra-clean vacuum because no grease is used for lubrication of bearings.

Two touch down bearings are provided to stabilize the rotor mechanically if impacts occur during operation. They are only used in case of the breaking of the power supply cable during operation, strong shocks, or faulty electronics.

Motor and control

A DC motor without commutator is used to power the rotor.

Drive voltage for the motor and the operating voltage for the magnetic bearing are supplied by the MAG.DRIVE frequency converter. It also handles the automatic monitoring of these systems.

The pump is equipped with a data storage device which stores the important operating parameters during the complete operation time of the pump.

The converter monitors continuously all important operating parameters and provides warning and alarm signals in case the operating conditions exceed the specification or the set threshold.

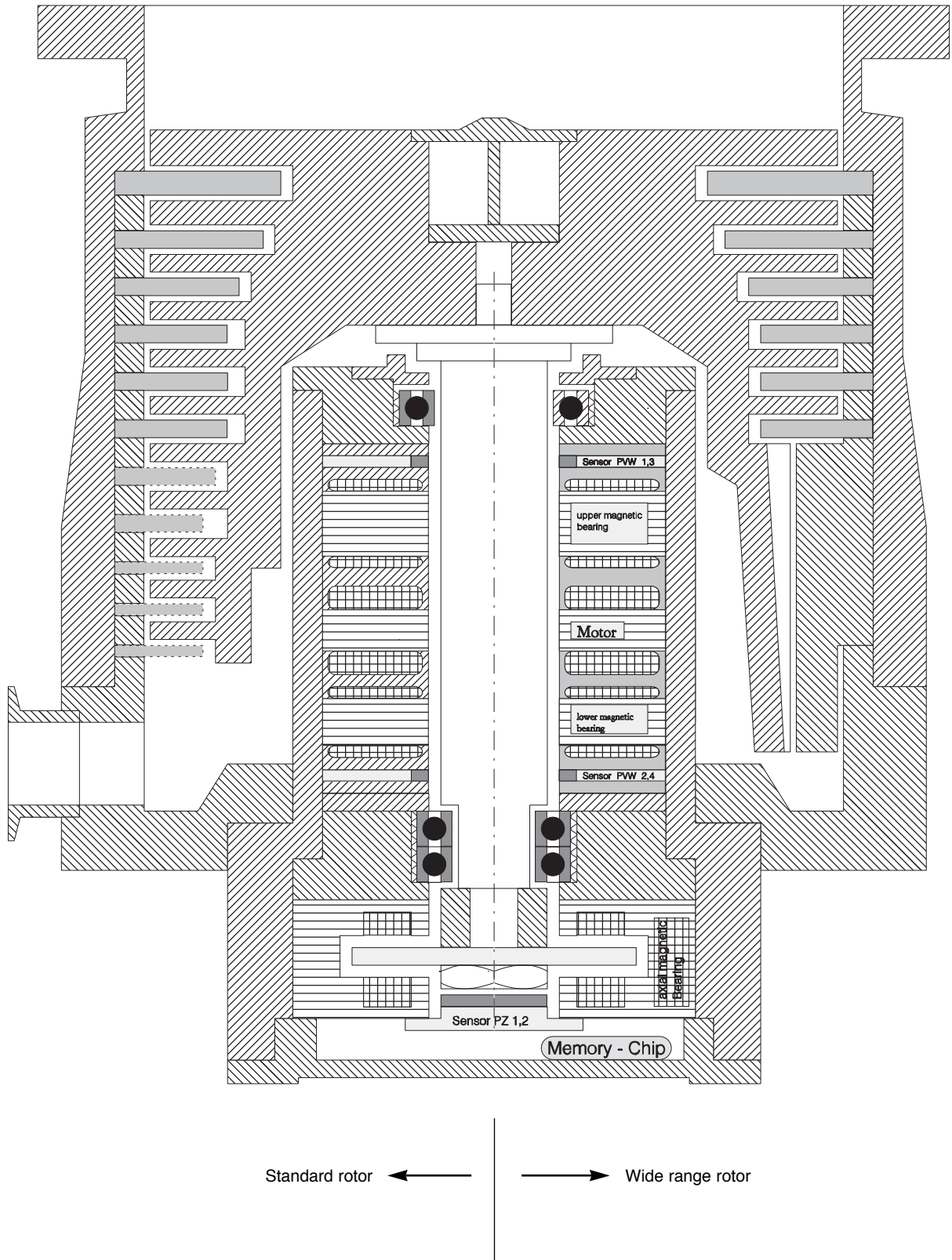

Fig. 4 Section of a MAG (W) 2000

1.4 Function and design of the MAG.DRIVE

The MAG.DRIVE L and MAG.DRIVE L2 electronic converters are used to drive the MAG turbo-molecular pumps.

The electronic converters convert the single-phase line supply voltage into a three-phase DC voltage to control and monitor the electronically-commutated DC motor. It also evaluates measured signals and controls (open-loop and closed-loop) the pump functions.

The temperature management system (TMS) and the magnetic bearing control system are integrated into the converter. The TMS regulates the pump temperature by switching the heating on/off or cooling the pump. The magnetic bearing control system actively controls the pump rotor in five axes (closed-loop control).

All parameters required for pump operation and the listed faults and operating hours are stored in a non-volatile memory in the pump. When the converter is switched on, the data are loaded into the converter from the pump.

The outputs of the electronic converter are no-load and short-circuit proof.

The electronic converter can be connected via its serial interface to external open-loop control and monitoring devices. More detailed information on the serial interface and the interface protocol are provided in the Option Manual "MAG.DRIVE serial interface".

For remote control via control connector X1 we recommend that either a relay or optocoupler is used to provide electrical isolation.

Housing

The converter is supplied with a closed housing. It can be installed in a 19" cabinet

Front panel

Main switch

9-pin connecting socket for the RS232 interface

7 short-stroke keys

1 backlit LCD with 2 lines, each 16 characters, 8 mm character height

1 green/red STATUS LED

1 green COM LED (communications interface)

1 green MAIN LED (line supply voltage)

Rear panel

X1 25-pin D socket connector for remote monitoring and open-loop control

X7.2 9-pin D connector for RS232

X10 3-pin Hirschmann connector for the connection to the mains supply

X24 64-pin Harting socket connector for internal sensors and magnetic bearing connection

X26 10-pin Harting socket connector for the motor connection

X31 25-pin Harting socket connector for the TMS and purge valve connection

X33 3-pin terminal strip, 24 V output voltage (e.g. for the power failure airing valve)

F1 Fuse for mains power supply (only MAG.DRIVE L2)

F2 Fuse for power supply of the active magnetic bearing (only MAG.DRIVE L2)

F3 Fuse for the heating (TMS)

1 or 2 protective earth terminals

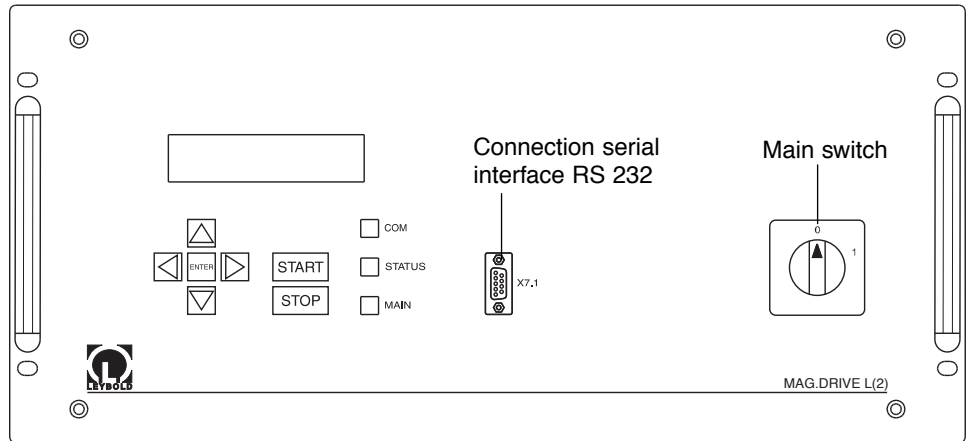
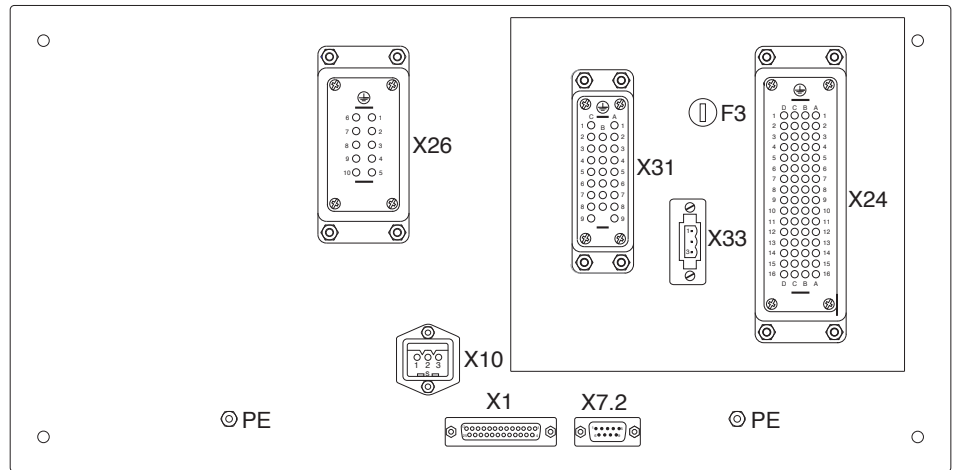
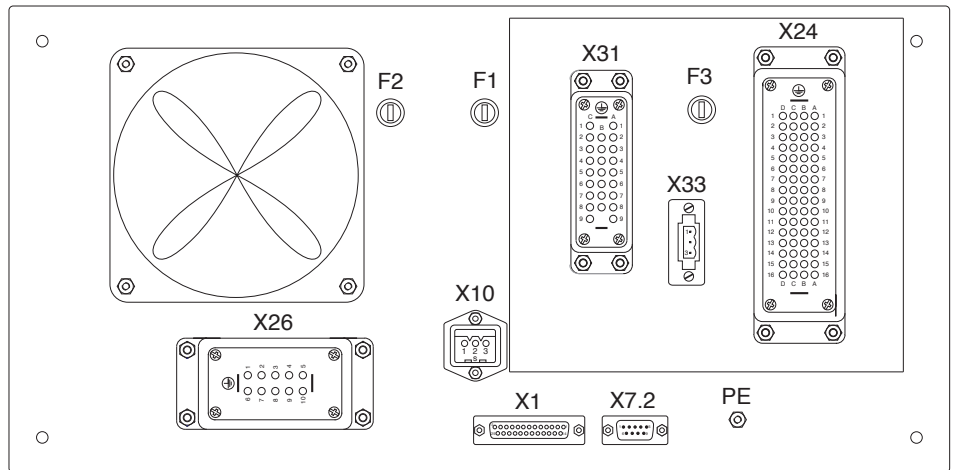

Fig. 5 Front panel

- X1 Connection control plug
- X7.2 Connection serial interface RS 232
- X10 Mains connection
- X24 Connection magnetic bearing
- X26 Connection pump motor
- X31 Connection TMS
- X33 Output 24 V
- F1 Fuse mains
- F2 Fuse bearing
- F3 Fuse TMS
- PE Protective earth



MAG.DRIVE L



MAG.DRIVE L2

Fig.6 Rear panel with connections

1.5 Standard specification

MAG

The turbomolecular pumps are shipped complete, sealed in a PE bag containing a desiccant.

The maximum effective life of the desiccant is one year.

The intake flange is sealed with a transport seal, the forevacuum flange with a plastic cap.

For the intake flange, a centering ring with FPM O-ring, outer ring, and a splinter guard are enclosed.

We also provide the bolts for attaching the pump to your tool. To avoid any safety risk we highly recommend using only the bolts provided with the pump. Refer also to Section 2.4 „Connecting the MAG ...“.

The electronic frequency converter MAG DRIVE as well as the cables required for operation must be **ordered seperately**.

In addition, a seal kit is included to seal the pump tightly if it is removed from the process.

MAG.DRIVE

- Converter
- Line supply cable with USA connector, approx. 3m
- Line supply cable with EURO connector, approx. 3 m
- Spare fuses (miniature fuses 5 x 20 mm)
 - F1 for the mains power supply (F8A) (only MAG.DRIVE L2)
 - F2 for the power supply of the active magnetic bearing (T3.15A) (only MAG.DRIVE L2)
 - F3 for the heating (F4A)

Cable Set

- Bearing cable
- TMS cable
- Drive cable

1.6 Technical data

MAG		1600 C/CT	W 1600 C/CT	2000 C/CT	W 2000 C/CT
Pumping speed for N ₂ measured with splinter guard (PNEUROPO)	l·s ⁻¹	1250	1300	1550	1650
Gas flow (continuous operation with Argon)	sccm	1000	1000	1000	1000
Compression for N ₂		>10 ⁸	>10 ⁸	>10 ⁸	>10 ⁸
Ultimate pressure as to DIN 28 400	mbar	< 10 ⁻⁸	< 10 ⁻⁸	< 10 ⁻⁸	< 10 ⁻⁸
Max. forevacuum pressure with Nitrogen	mbar	1.5	3.3	1.5	3.3
with Argon	mbar	1.5	4.1	1.5	4.1
Rotor Speed	min ⁻¹			28,800	
Run-up time	min			< 10	
Braking time with/without venting	min			1 / < 7.5	
Cooling				water	
Cooling connection, Swagelok elbow for tube OD	mm			6.4 (1/4")	
Cooling water temperature	°C			15 to 30	
	°F			59 to 86	
Base flange temperature C version (depending on the load)	°C			30 to 50	
	°F			86 to 122	
Base flange temperature CT version (controlled)	°C			30 to 63	
	°F			86 to 145	
Weight	approx. kg	70	65	68	62
High-vacuum connection flange	DN	200 ISO-F	200 ISO-F	250 ISO-F	250 ISO-F
Forevacuum connection flange	DN	40 KF	40 KF	40 KF	40 KF
Recommended backing pump	DRYVAC	100	50	100	50
Admissible ambient temperature	°C			5 to 40	
	°F			40 to 104	
Storage temperature	°C			-10 to +60	
	°F			14 to 140	

Purge Gas

Purge gas connection pressure, abs.	1.2 - 2.0 bar
Purge gas: dry nitrogen, argon or similar	
Purge gas throughput at purge gas pressure 1.5 bar abs.	0.6 mbar·l·s ⁻¹ 36 sccm
Connection: VCR Nut	1/4"

MAG.DRIVE

Voltage range	200 - 240 V +10% -15%
Line supply frequency	50 / 60 Hz
Load	
Stand-by	approx. 100 W
Continuous (rated speed)	810 W
Maximum	1800 W
Max. voltage motor	60 V
Maximum pump current (Accel.)	20 A dc_peak
Continuous pump current, max.	13 A dc_peak
Maximum frequency	480 Hz
Load capability, relay output	42 V, 1 A
Temperature during operation	
MAG.DRIVE L	0-40° C
MAG.DRIVE L2	0-45° C
Storage temperature	- 10° C to + 60° C
Relative air humidity	Class F acc. to DIN 400 40
Weight	16 kg
Dimensions W x H x D (mm)	465 x 222 x 350 + connector depth 130

The units have degree of protection IP20 in accordance with EN 60529

(protection against the ingress of solid foreign bodies > 12 mm diameter (finger). It is not protected against the ingress of water with damaging effects.)

An increased degree of protection, e.g. IP54 can only be implemented by mounting the converter in an additional housing.

1.7 Ordering data

	Order No.
MAG 1600 C	894 14
MAG W 1600 C	894 15
MAG 2000 C	894 16
MAG W 2000 C	894 17
MAG 1600 CT	894 28
MAG W 1600 CT	894 29
MAG 2000 CT	894 30
MAG W 2000 CT	894 31
Seal Kit DN 200	200 91 684
Seal Kit DN 250	200 91 641
MAG.DRIVE L converter	857 24
MAG.DRIVE L2 converter	857 23

Connecting cables, converter / pump

Length	Cable BEARING	Cable DRIVE	Cable TMS
3 m	859 50	859 51	859 52
5 m*	859 53	859 54	859 55
10 m*	859 56	859 57	859 58
20 m*	859 62	859 63	859 64
3 m with bended plugs	859 68	859 69	859 70

The cables with straight plugs are shown in Fig. 3, the cables with bended plugs in Fig. 34.

- MAG.WIN, an operator control interface which can run under Windows with user instructions as Windows help on request
- Connecting cable serial interface (front panel, 9-pin D-connector), approx. 5 m long on request

* only permissible if the pump is mounted in a vertical position

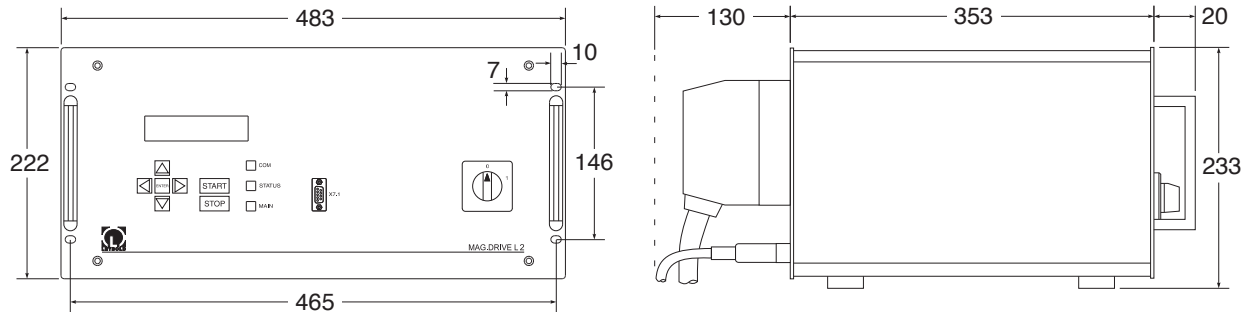
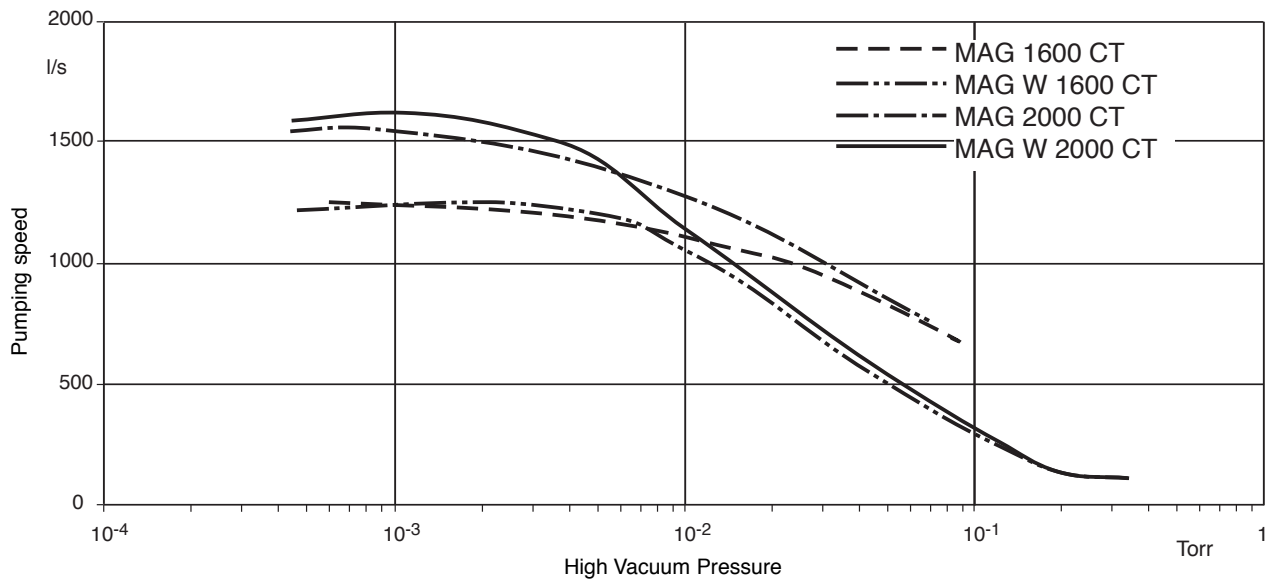

Fig. 7 Dimensional drawing of the MAG.DRIVE; dimensions in mm



Rotor speed 480 Hz
 Purge gas flow 36 sccm Nitrogen
 with splinter guard
 Forepump
 for MAG 1600 CT D 65 B + WS 501
 for MAG W 1600 CT D 65 B + WS 251
 for MAG 2000 CT D 65 B + WS 501
 for MAG W 2000 CT D 65 B + WS 251
 Pipe 1 m DN 40
 according to PNEUROP

Fig. 8 Pumping speed curves for Nitrogen

Description

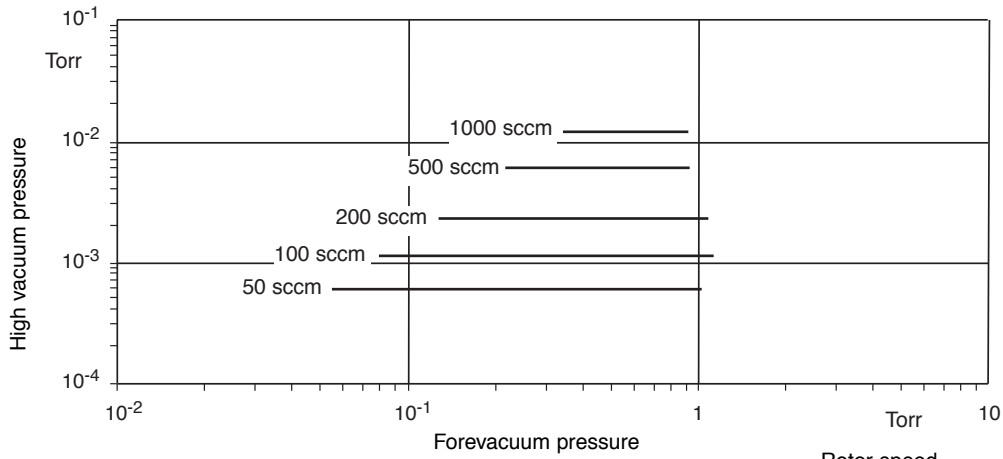

Rotor speed 480 Hz
 Purge gas flow 36 sccm Nitrogen
 with splinter guard
 Forepump D 65 B + WS 501
 Pipe 1 m DN 40
 according to PNEUROP

Fig. 9 MAG 1600 C/CT: operation diagram for nitrogen

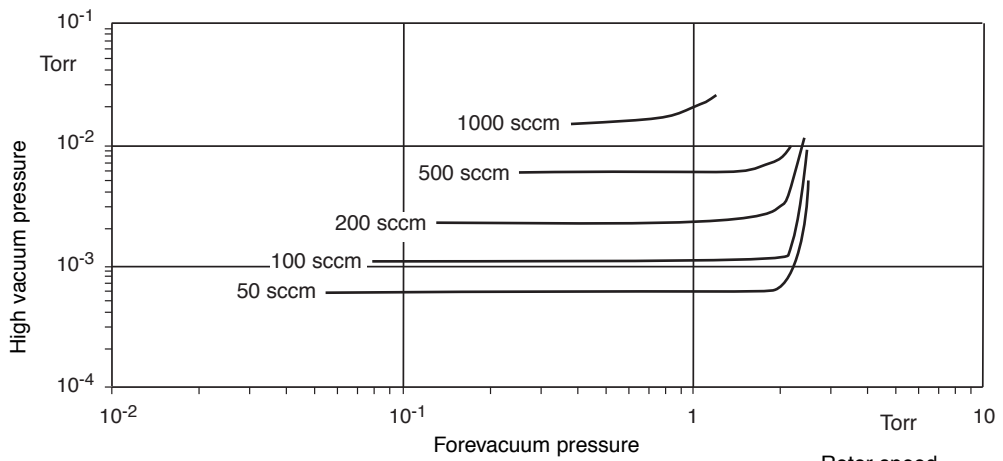

Rotor speed 480 Hz
 Purge gas flow 36 sccm Nitrogen
 with splinter guard
 Forepump D 65 B + WS 251
 Pipe 1 m DN 40
 according to PNEUROP

Fig. 10 MAG W 1600 C/CT: operation diagram for nitrogen

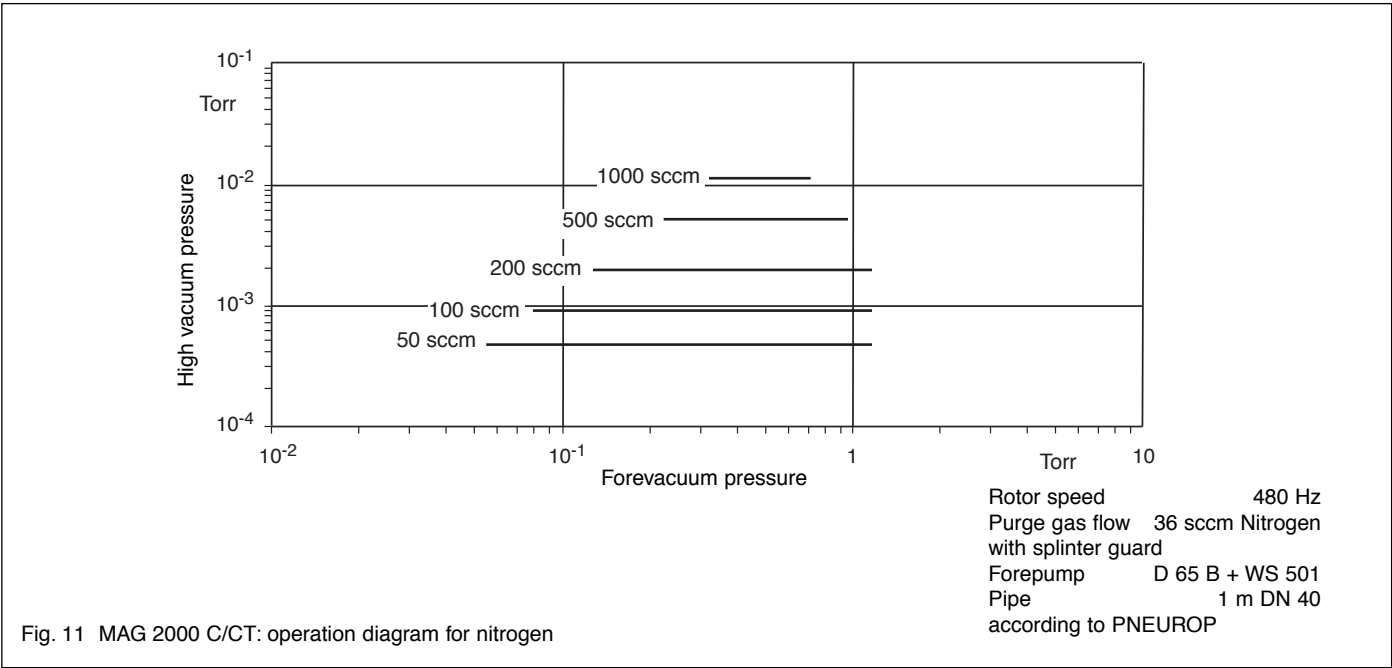

Fig. 11 MAG 2000 C/CT: operation diagram for nitrogen

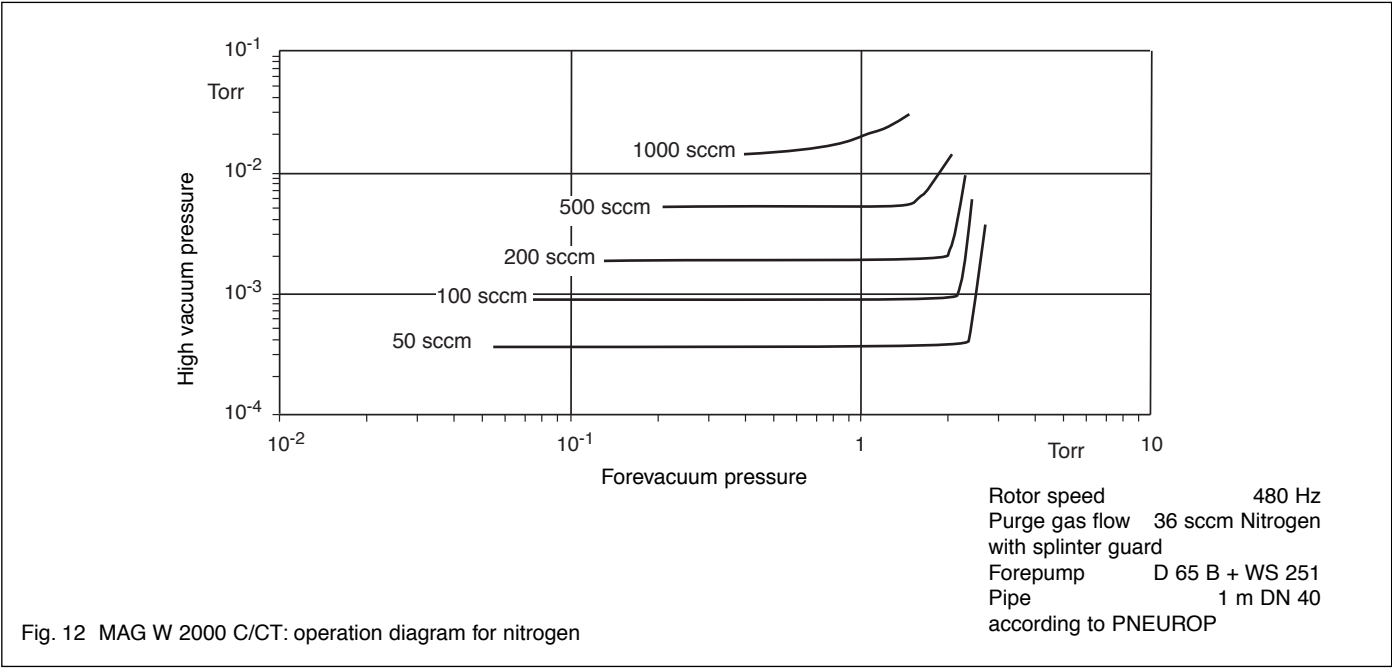

Fig. 12 MAG W 2000 C/CT: operation diagram for nitrogen

MAG 1600 C Cat. No. 894 14

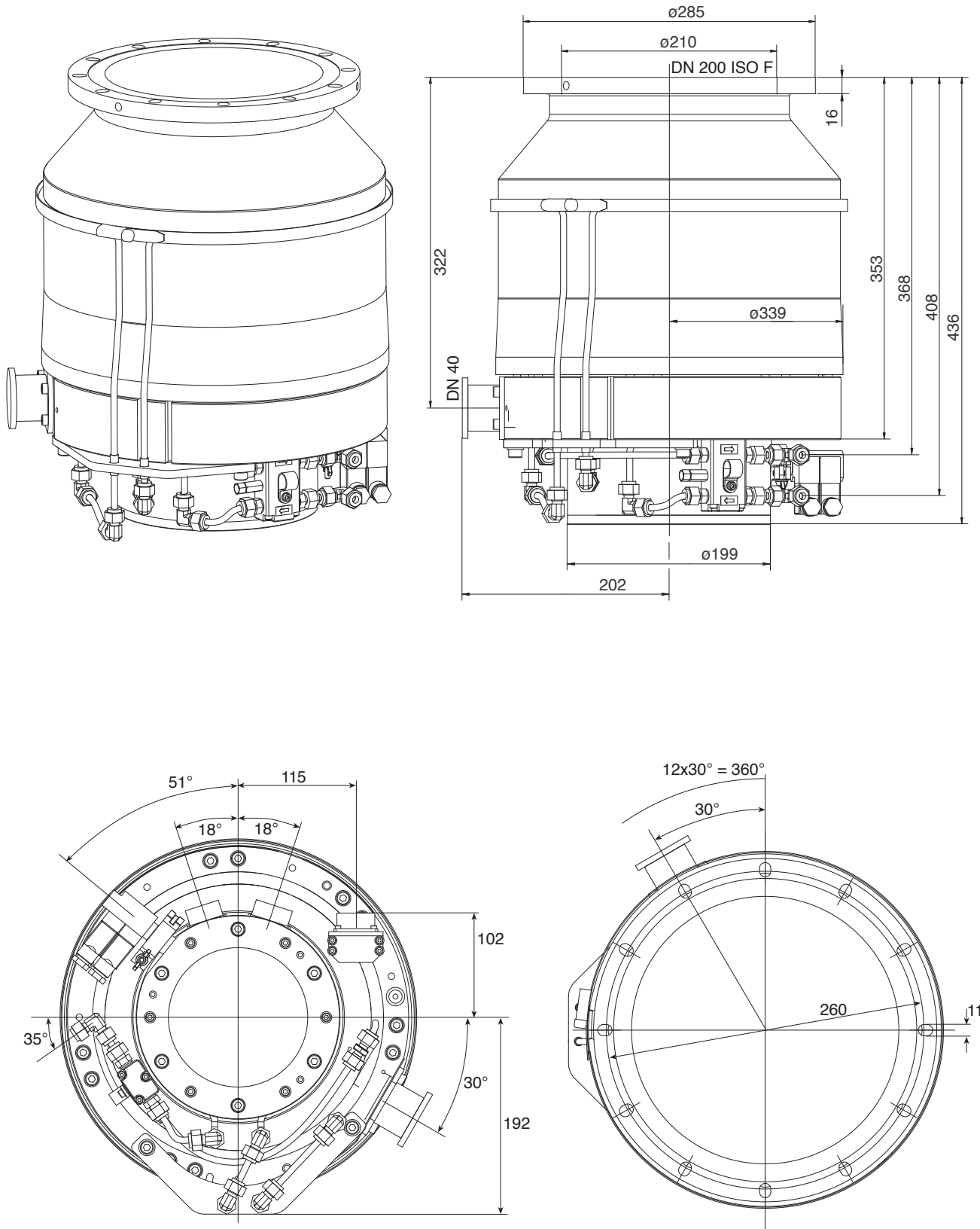

Fig. 13 MAG 1600 C, Dimensions in mm

MAG W 1600 C Cat. No. 894 15

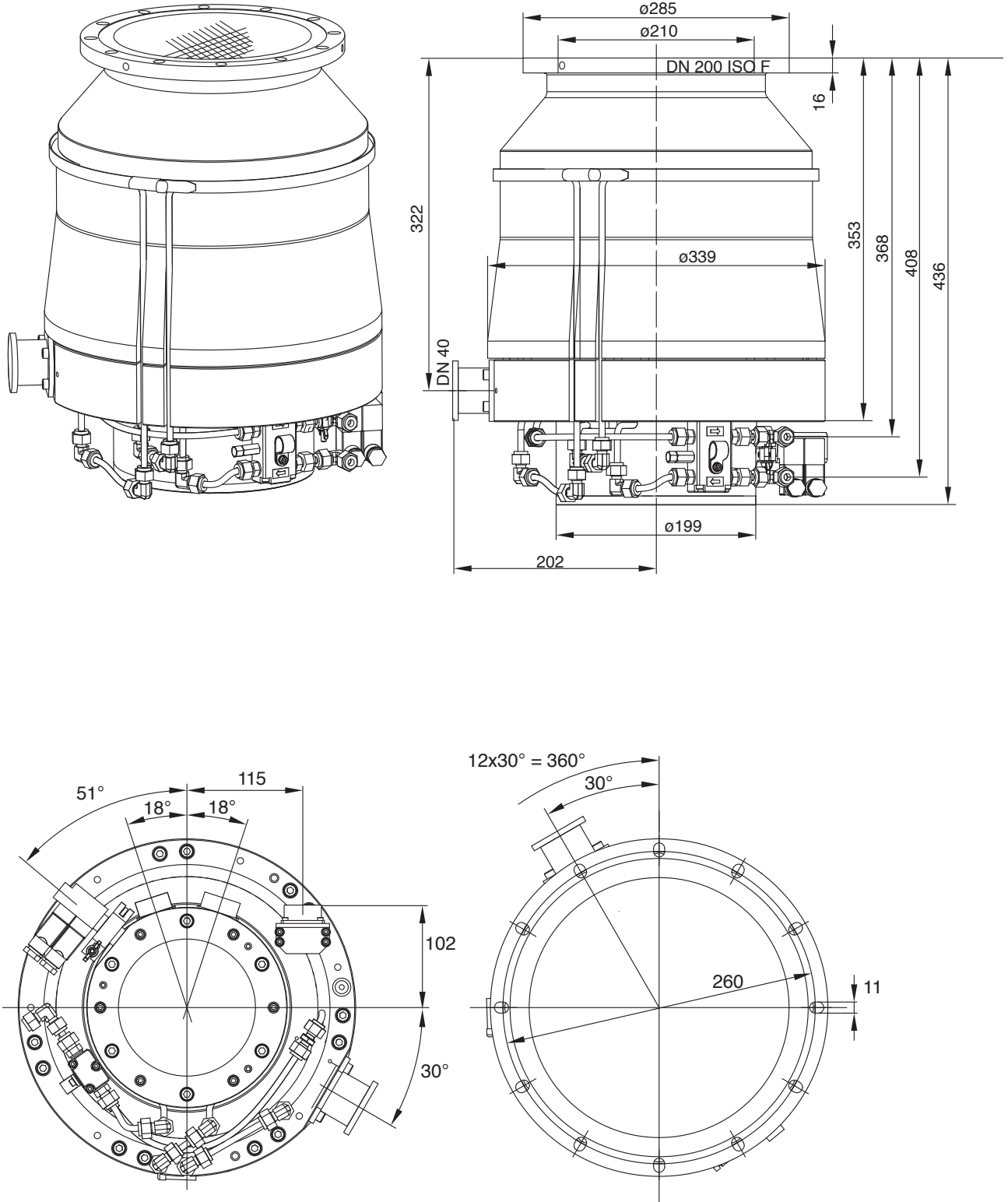

Fig. 14 MAG W 1600 C, Dimensions in mm

MAG 1600 CT Cat. No. 894 28

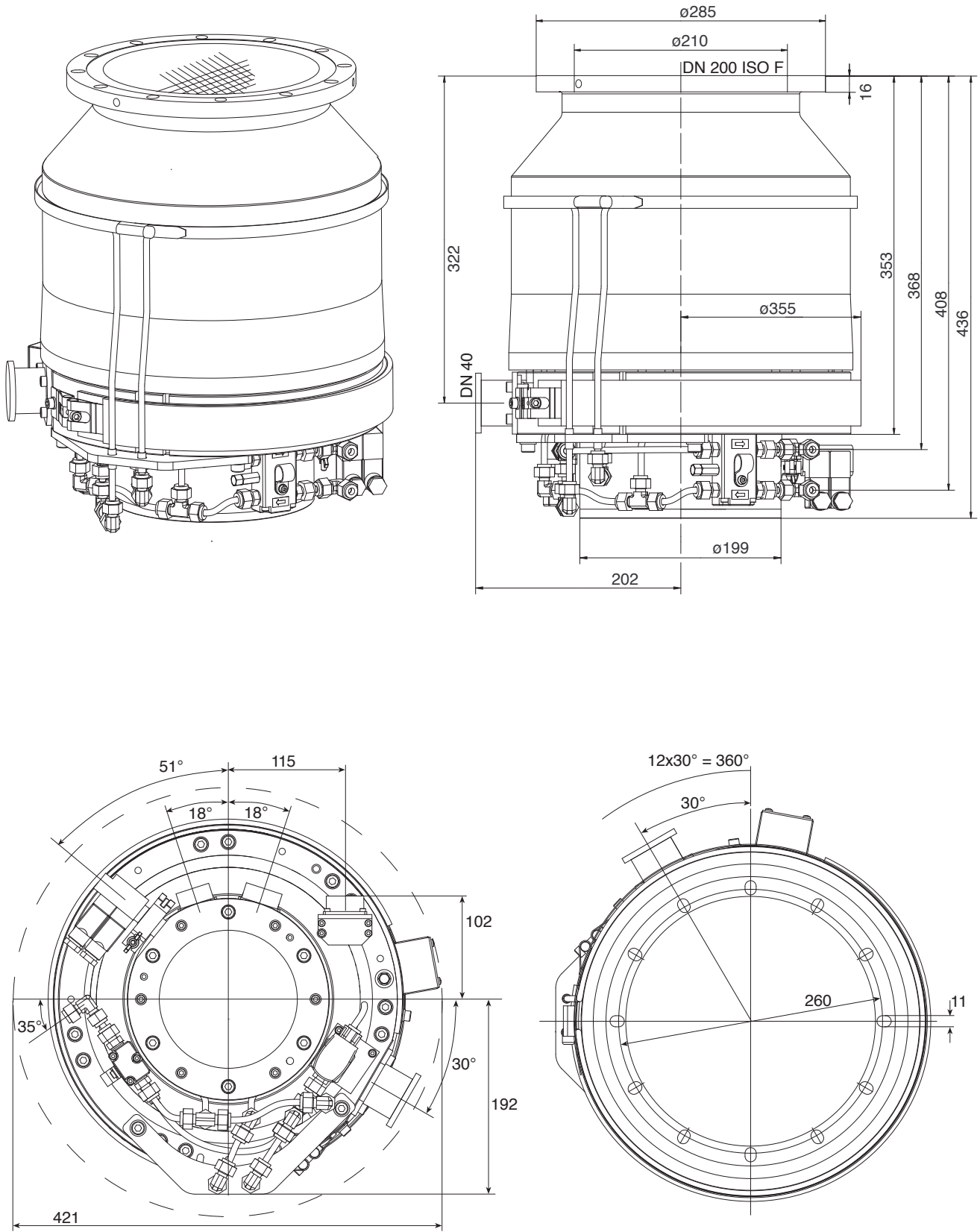

Fig. 15 MAG 1600 CT, Dimensions in mm

MAG W 1600 CT Cat. No. 894 29

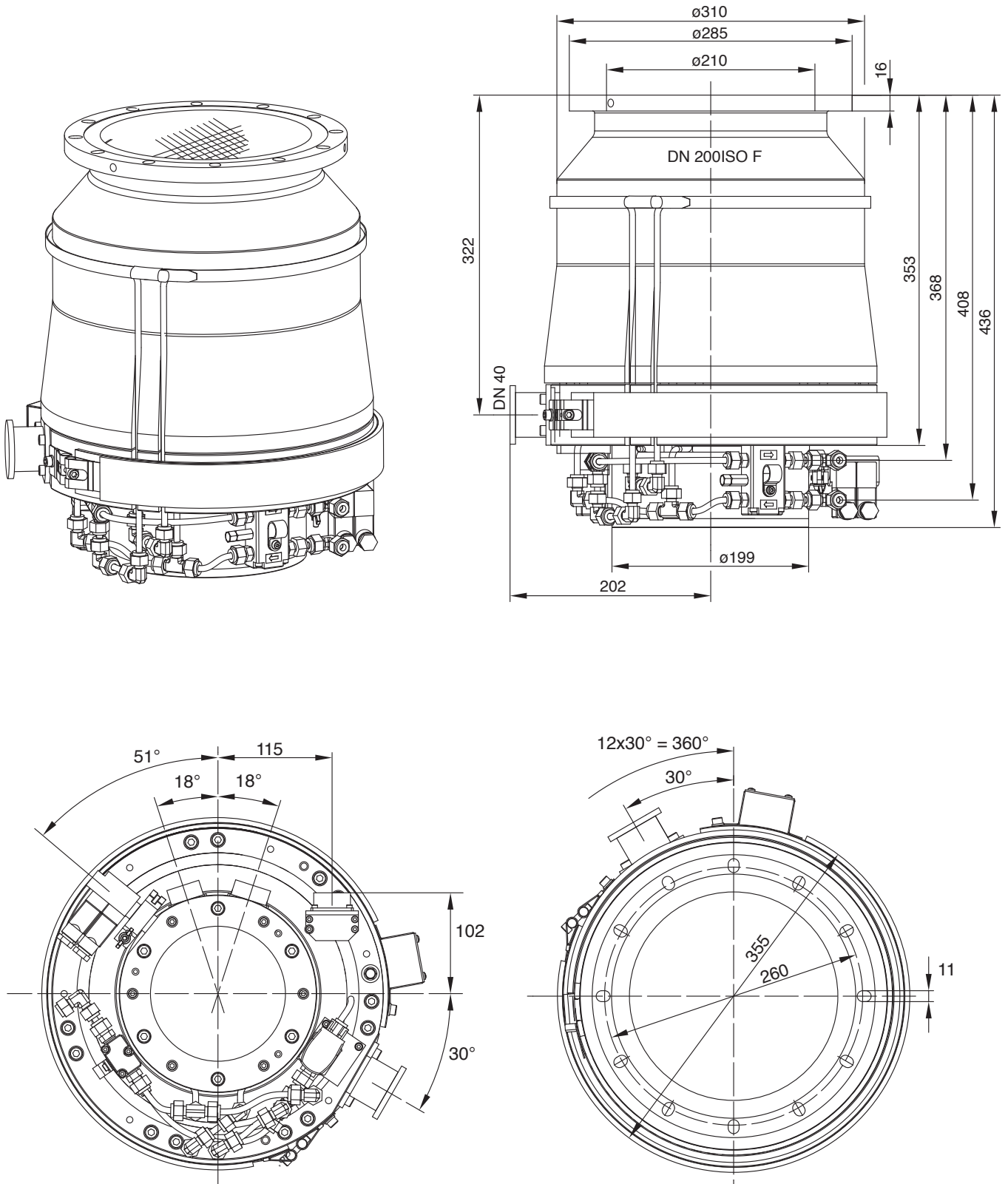

Fig. 16 MAG W 1600 CT, Dimensions in mm

MAG 2000 C Cat. No. 894 16

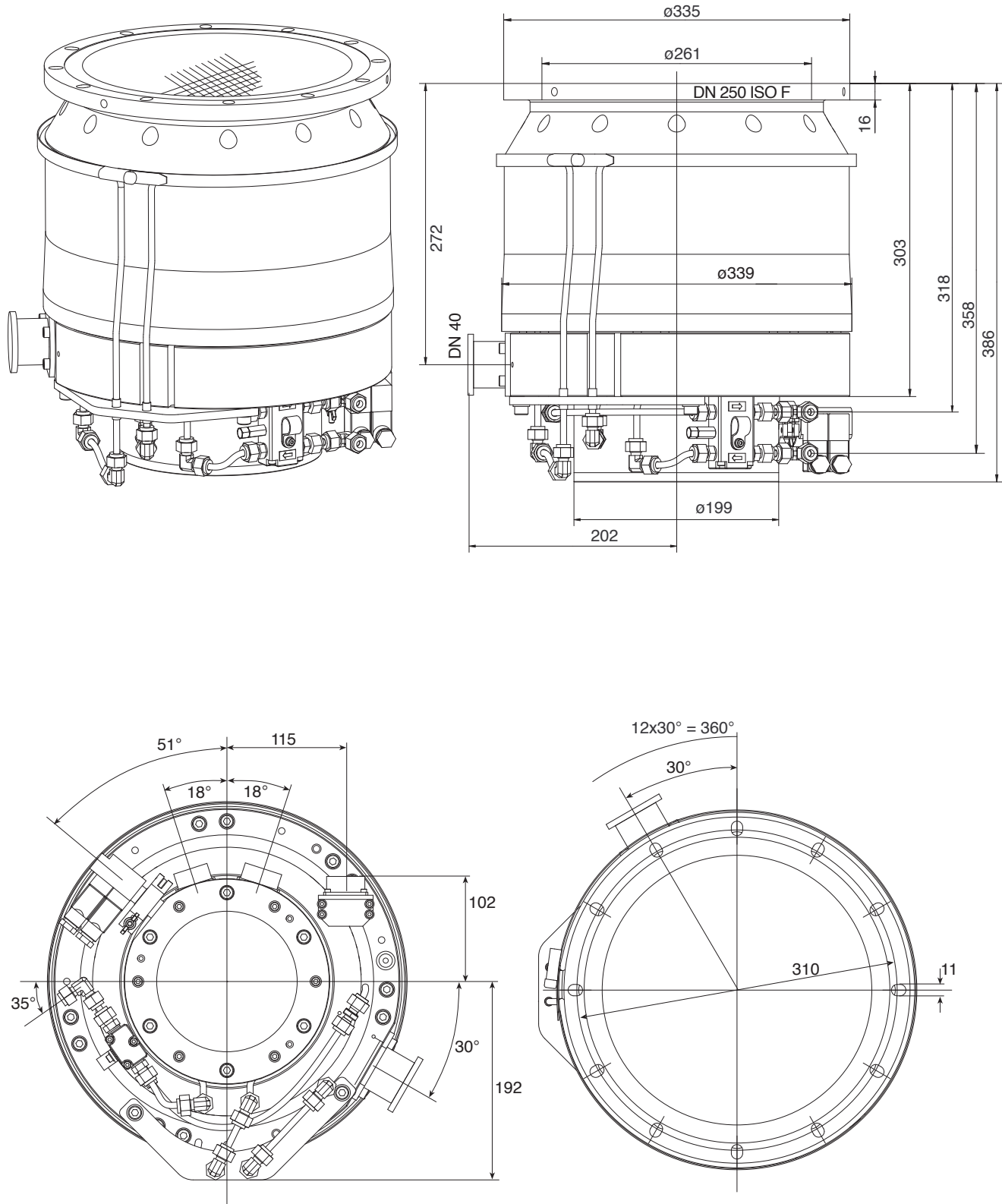

Fig. 17 MAG 2000 C, Dimensions in mm

MAG W 2000 C Cat. No. 894 17

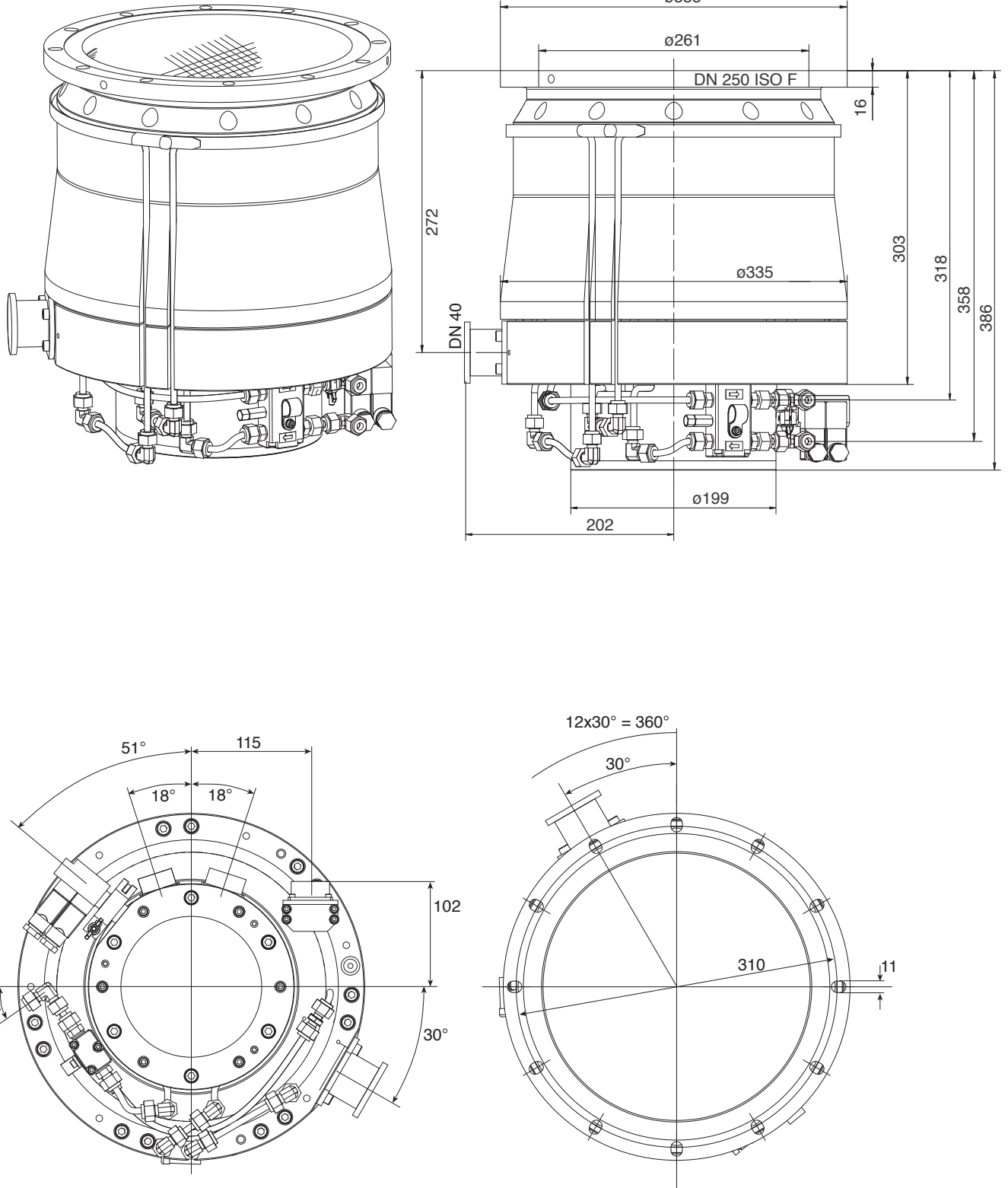

Fig. 18 MAG W 2000 C, Dimensions in mm

MAG 2000 CT Cat. No. 894 30

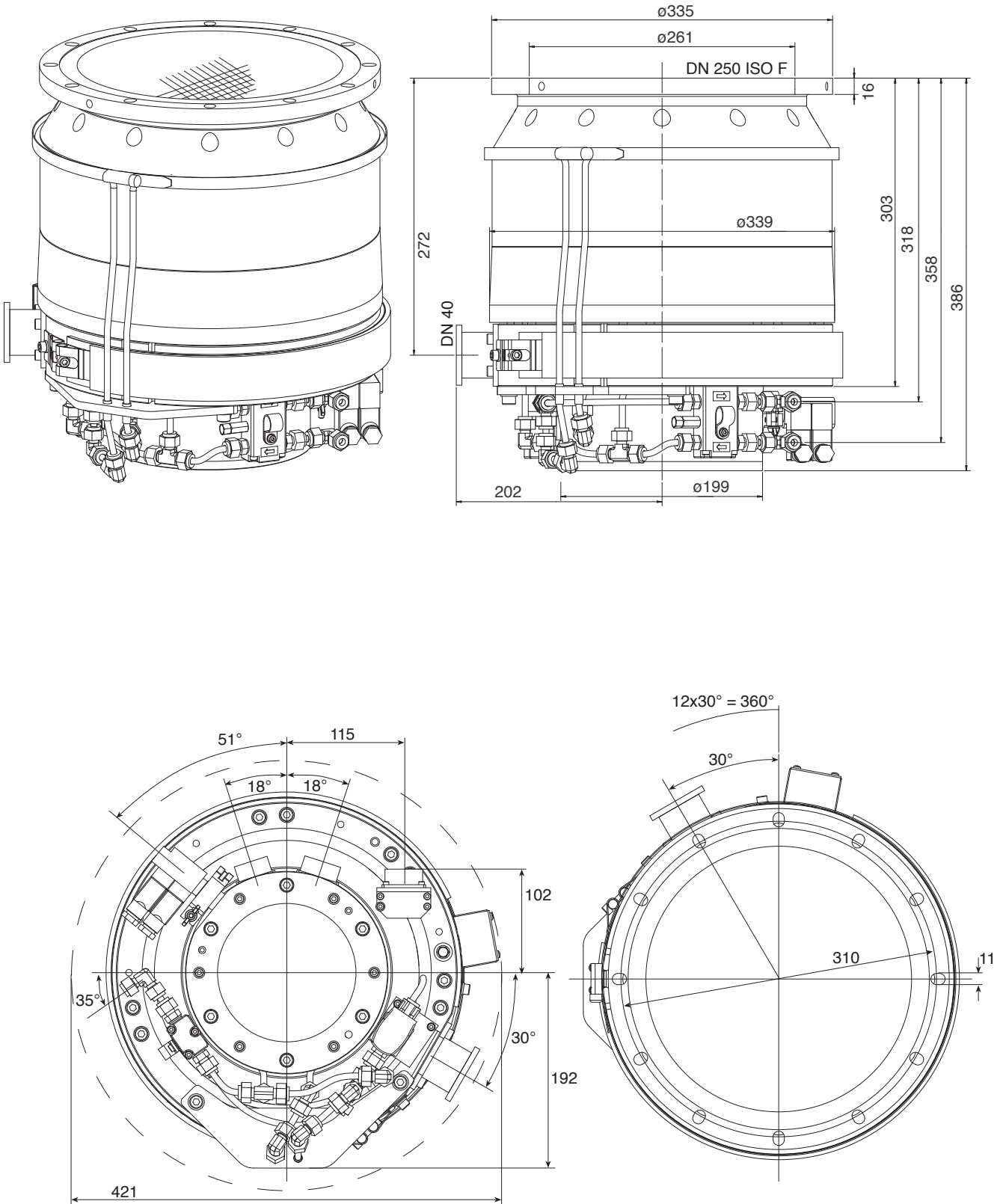

Fig. 19 MAG 2000 CT, Dimensions in mm

MAG W 2000 CT Cat. No. 894 31

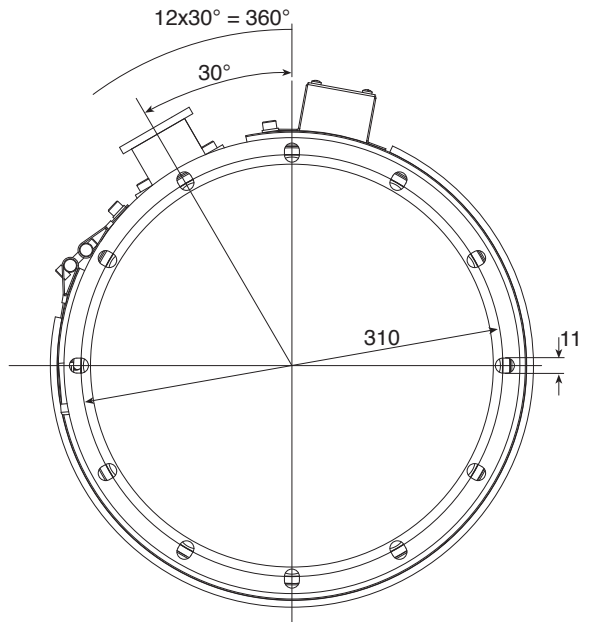
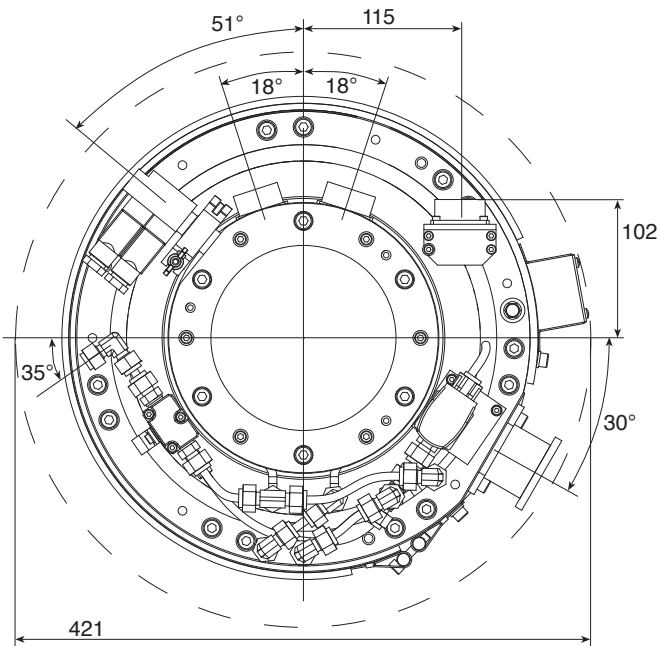
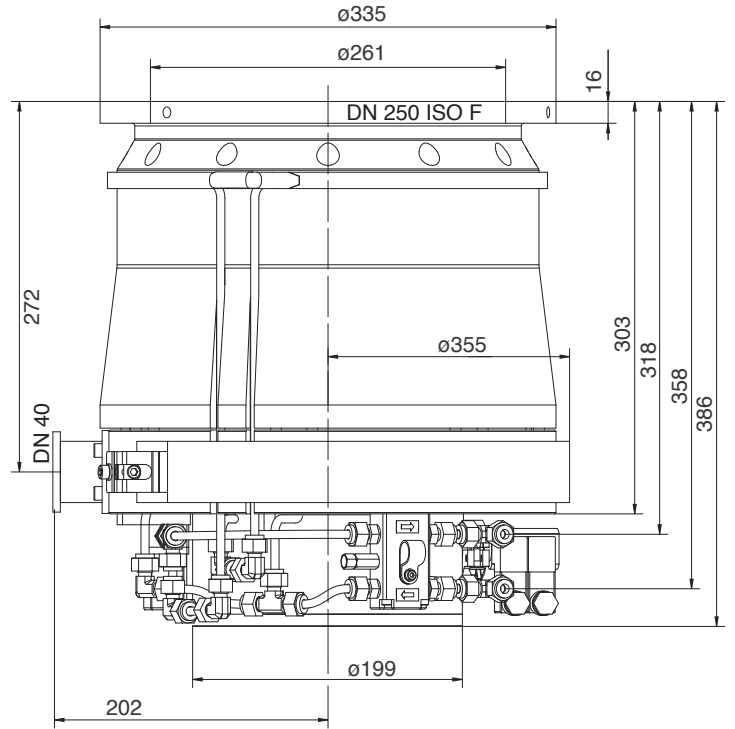
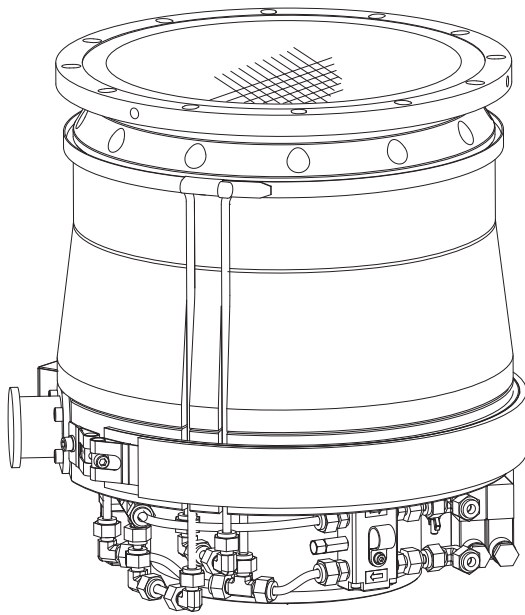

Fig. 20 MAG W 2000 CT, Dimensions in mm

2 Installation

2.1 General safety information

Warning

Indicates procedures that must be strictly observed to prevent hazards to persons.

Caution

Indicates procedures that must be strictly observed to prevent damage to, or destruction of the MAG.

Warning



Never expose any parts of the body to the vacuum.

Warning



The converter has dangerous voltage levels.

Failure to strictly follow the instructions in this Manual can result in death, severe bodily injuries or significant material damage.



Only suitably qualified personnel are permitted to work on the pump or converter. Personnel must be completely knowledgeable of all warning information and measures which are specified in this Instruction manual for transporting, installing, and operating the unit.

Qualified personnel

Qualified electrical personnel in this instruction manual means a person who has received electrical engineering instruction or is an electrical expert in accordance with EN 60204, Part 1, 3.30 respectively 3.55.

Warning

The device contain electrostatically sensitive devices (ESD)!



Warning



Before opening the converter, always disconnect from the mains! When applying external voltage in excess of 42 V to terminals of the device, observe local safety regulations!

Unauthorized device conversion and modifications are prohibited for safety reasons.

Please keep this Operating Instruction for future reference.

2.2 Unpacking - storing - transportation

Remove the equipment from the transportation box and keep the packaging. Make sure that the product has not been damaged during transportation. If this unit is damaged contact your carrier and inform LEYBOLD if necessary. For storage of the product, use the packaging provided.

Lift the pump by the crane eyelets or move it with at least two persons.

You can position the pump on the base plate for transport with a lift-truck. Protect the pump against slipping and tipping over.

Caution

Be careful not to damage the sockets and coolant connections during transportation.

Do not stand below the pump while connecting or removing the MAG.

The MAG is shipped in a sealed PE bag with desiccant. Do not open the sealed package until immediately before installing.

Do not remove the covers and blanking flanges until you are ready to make the connections, to ensure that the MAG is installed under the cleanest possible conditions.

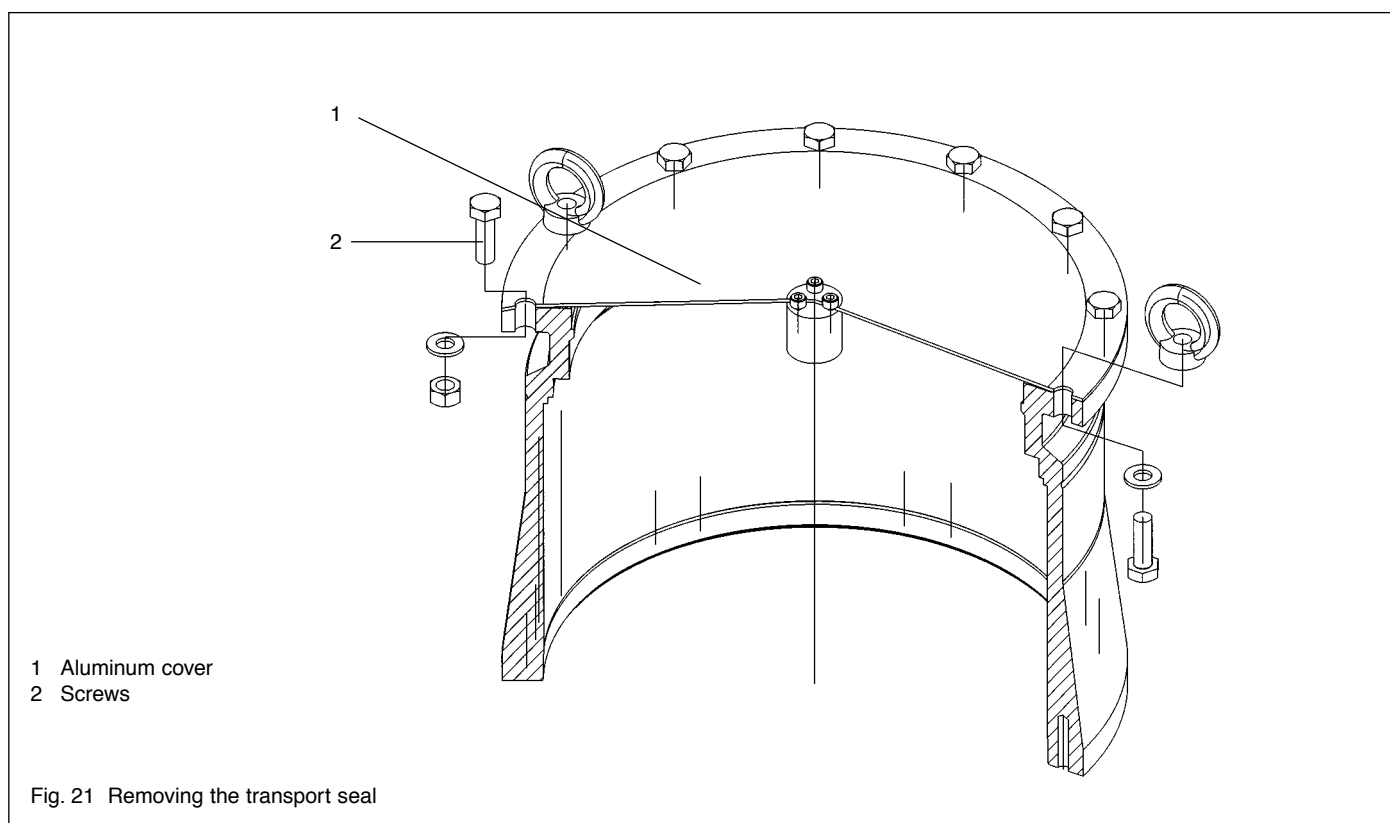

2.3 Operating environment

When using the MAG inside a magnetic field, the magnetic induction at the pump housing must not exceed 5 mT; (1 mT (milliTesla) = 10 G (Gauß))

Exceeding this limit can cause excessive rotor heating due to the eddy currents generated in this situation. It is therefore necessary to provide suitable shielding in such cases.

The standard version of the MAG is resistant to radiation at levels up to 10^3 Gy. (1 Gy (Gray) = 100 rad)

The ambient temperature must not exceed 40°C (104 °F).

The noise level when the pump is running is below 70 dB(A). No acoustic insulation is required.

2.4 Connecting the MAG to the vacuum chamber

The MAG is shipped in a sealed PE bag with desiccant. Do not open the package until immediately before installing.

Do not remove the covers and blanking flanges until you are ready to make the connections, to ensure that the MAG is installed under the cleanest possible conditions.

Pay attention to maximum cleanliness when connecting.

Remove the transport seal from the intake flange. To do so unscrew the screws (21/2) and remove the aluminum cover. We recommend saving the transport seal for maintenance.

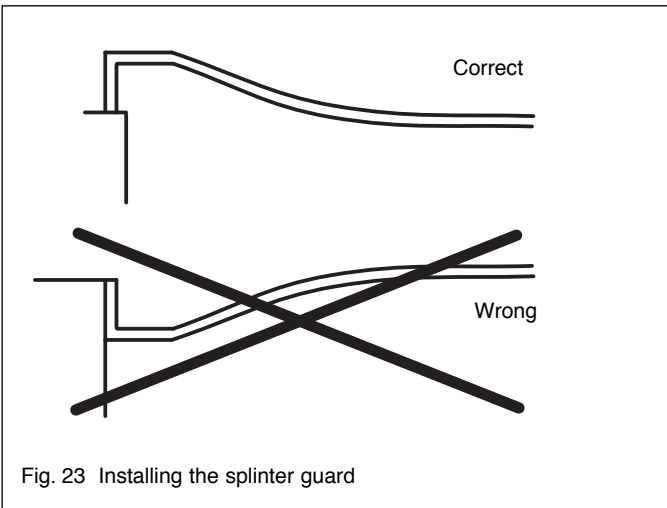
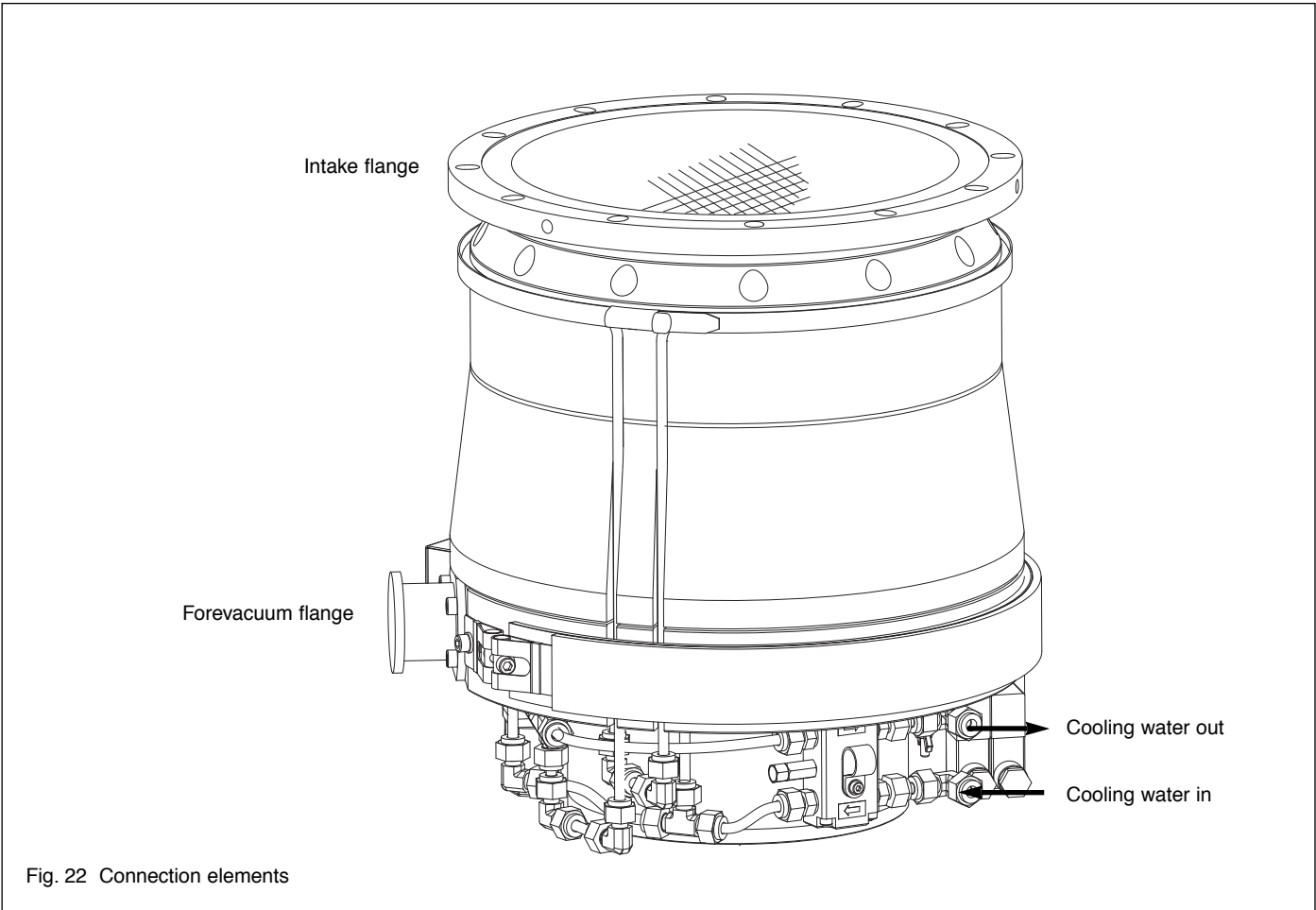

Foreign objects entering the pump through the high-vacuum flange can cause serious damage to the rotor. That's why the splinter guard must always be installed.

Damages caused during operation without the splinter guard are excluded from warranty.

Caution

Install the splinter guard as shown in Fig. 23. Installing the splinter guard upside down may lead to contact between splinter guard and rotor during fast venting of the pump.

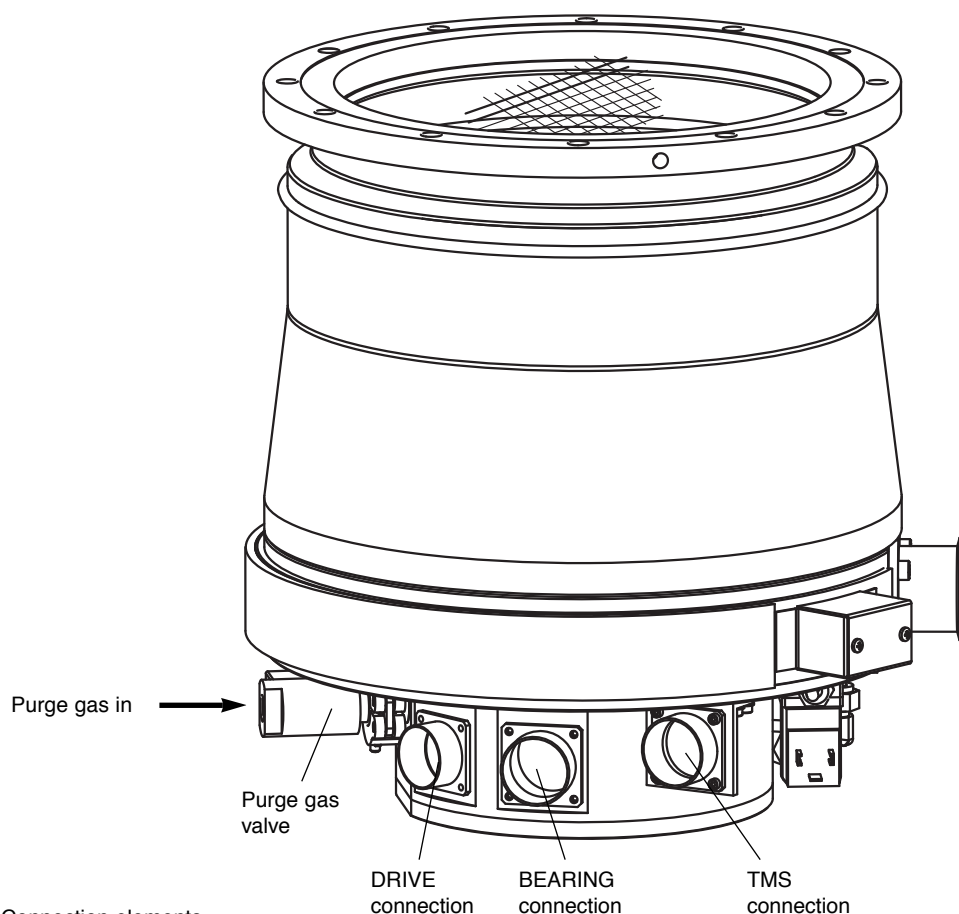

Fig. 24 Connection elements

Warning



The pump must be securely attached. If the pump should suddenly seize, inadequate attachment could cause the pump to break away or allow internal pump parts to be discharged. Never operate the pump (in bench tests, for instance) without its being connected at the vacuum chamber.

If the pump should suddenly seize, the deceleration torque of 60,000 Nm will have to be absorbed by the system. To accomplish this, use all 12 bolts provided by Leybold for fastening the high-vacuum flange; see also Fig. 25.

Mount the MAG as close as possible to the vacuum chamber. If the MAG is permanently flanged to a vacuum chamber with a weight exceeding 500 kg, it will not be necessary to secure it in any other way.

In case of lighter vacuum vessels secure the pump additionally. The pump's bottom is equipped with tapered holes for fastening a support; see Fig. 26.

If the pump is exposed to shocks, e.g. by a gate valve, secure the pump so that it is supported in the direction of the shock.

We recommend installing an isolation valve between the pump and the chamber. The valve should be closed during wet cleans of the chamber and in case of pump failures which will lead to a pump shut down. The valve should normally be closed with power off.

Warning



The basic flange heater can become so hot during operation ($> 80^{\circ}\text{C}$, $> 176^{\circ}\text{F}$) that it represents a burn hazard: Provide protection against contact with the hot components.

Mounting position and cable length

If the pump is mounted in a **vertical** position (intake flange up or down) the permissible length of the pump-converter cables is **3 to 20 meters**.

If the pump is mounted in a **horizontal** position the permissible length of the pump-converter cables is **3 meter**.

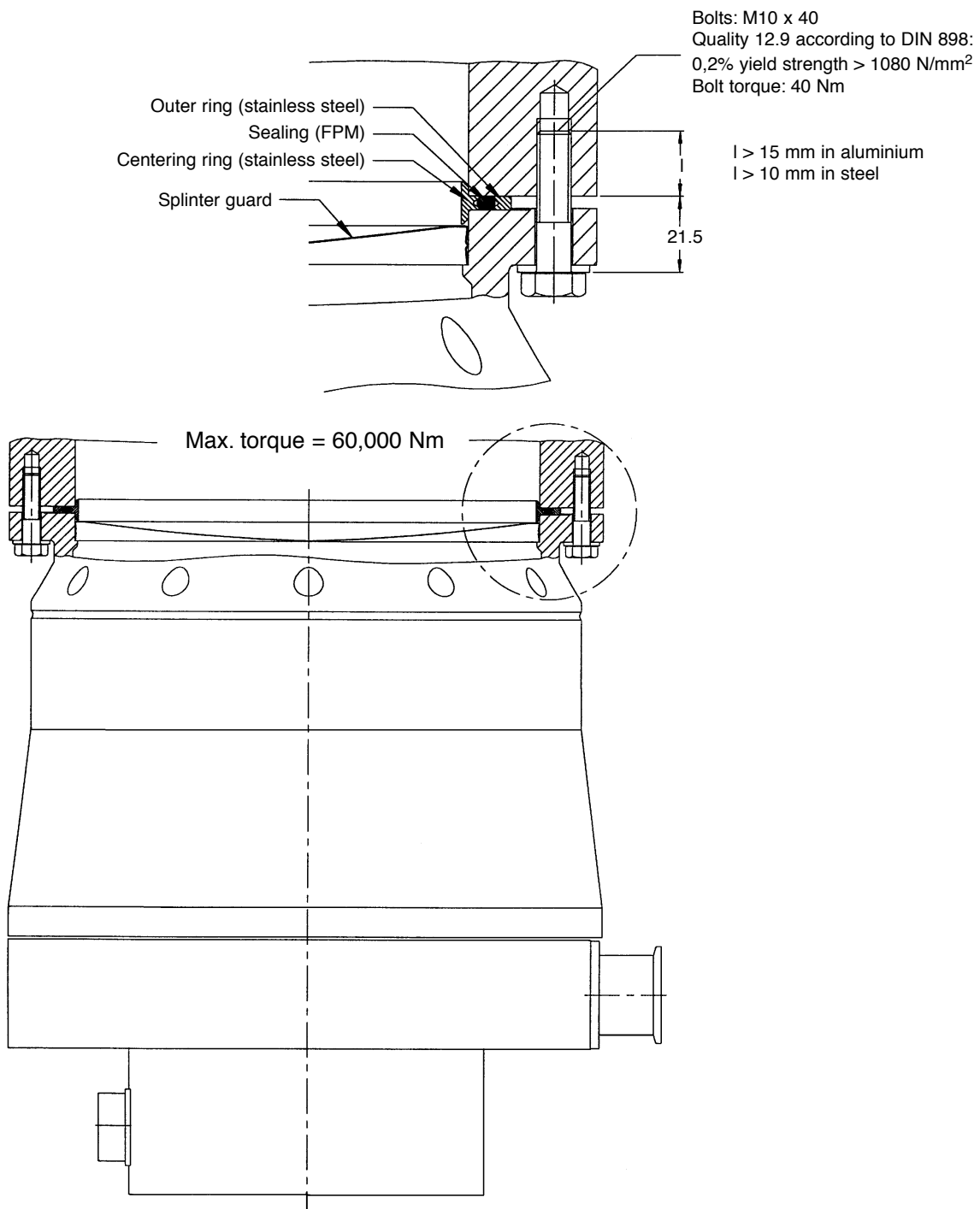

Fig. 25 Fixing the intake flange

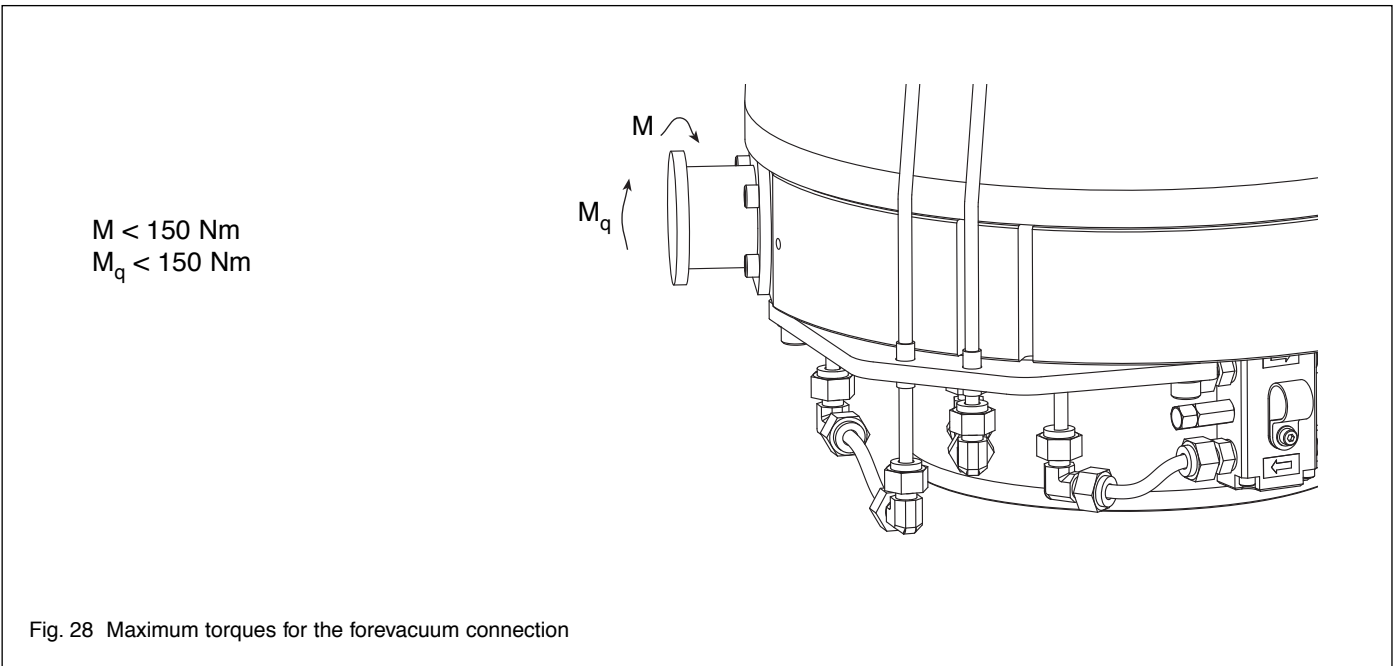

Fig. 28 Maximum torques for the forevacuum connection

2.5 Connecting the backing pump

A two stage rotary vane pump or dry-compression backing pump is required to support operation of the MAG.

We recommend using the DRYVAC or our TRIVAC-B pump for this purpose.

In case of high gas throughput, it may also be necessary to use a roots blower to achieve the backing pressure necessary for operating the MAG. We recommend our RUVAC blower for this purpose or our DRYVAC 251/501 systems.

Fig. 27 shows schematically the design of a pump system incorporating a MAG with an additional foreline valve and an isolation valve between chamber and MAG.

The foreline isolation valve is recommended to protect the MAG from shock venting in case of uncontrolled shut down of the backing pump. This valve must be able to close fast enough to avoid pressure increase in the MAG.

In case of an oil-sealed backing pump the foreline isolation valve protects the MAG from backstreaming oil vapor during standstill.

Connect the forevacuum flange of the MAG to the backing pump.

The torque on the forevacuum connection flange must not exceed the values shown in Fig. 28.

Warning



The forevacuum line must be tight. Hazardous gases can escape at leaks or the gases being pumped can react with the air or humidity. We recommend a leak check.

2.6 Connecting the cooling water

Cooling water specifications

Inlet temperature	15 - 30 °C
Inlet pressure	3 to 7 bar absolute
Cooling water requirement	See Fig. 30
Appearance	Colorless, clear, free of oils and greases
Sediments	< 250 mg/l
Particle size	< 150 µm
Electrical conductivity	< 500 µS/cm
pH value	7 to 8.5
Overall hardness (total alkaline earths)	max. 20 ° German hardness scale (= 3.57 mmol/l)

Further information on request.

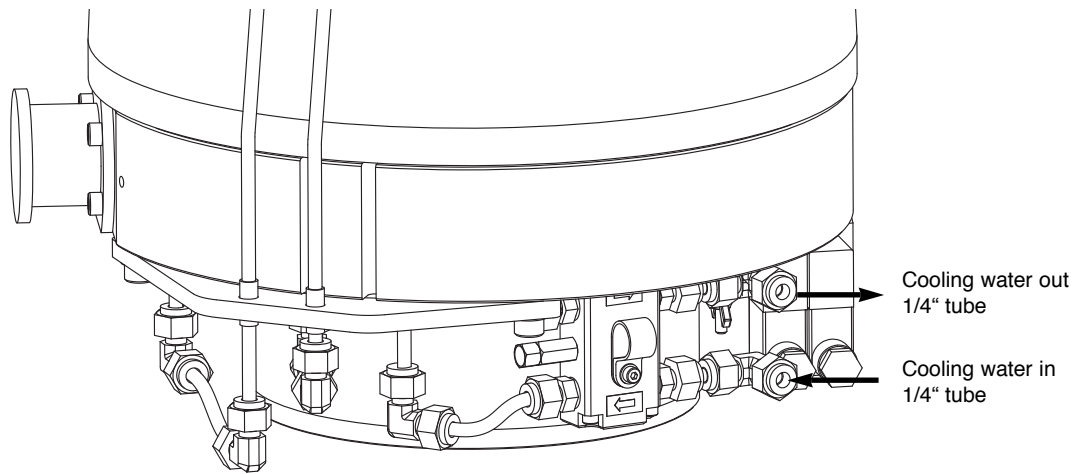

Fig. 29 Connecting the cooling water

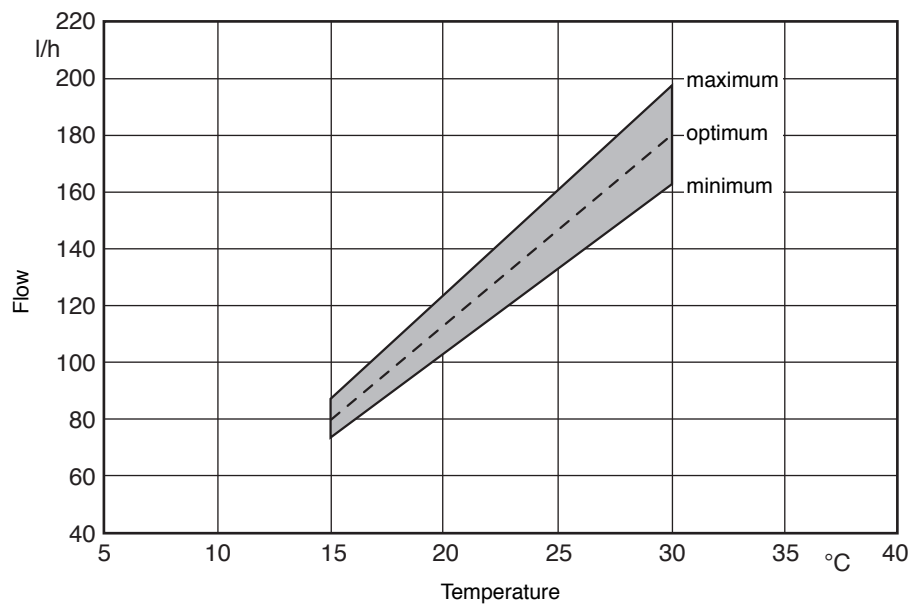

Fig. 30 Recommended cooling water flow as a function of cooling water temperature

Connect the cooling water to the connectors; see Fig. 29.

Make sure that you do not mix up the inlet and the outlet connection.

Turn off the cooling water supply when the pump is switched off in order to avoid condensate formation in the pump.

If you do not close the cooling water it may take longer to achieve ultimate pressure after start up of the system.

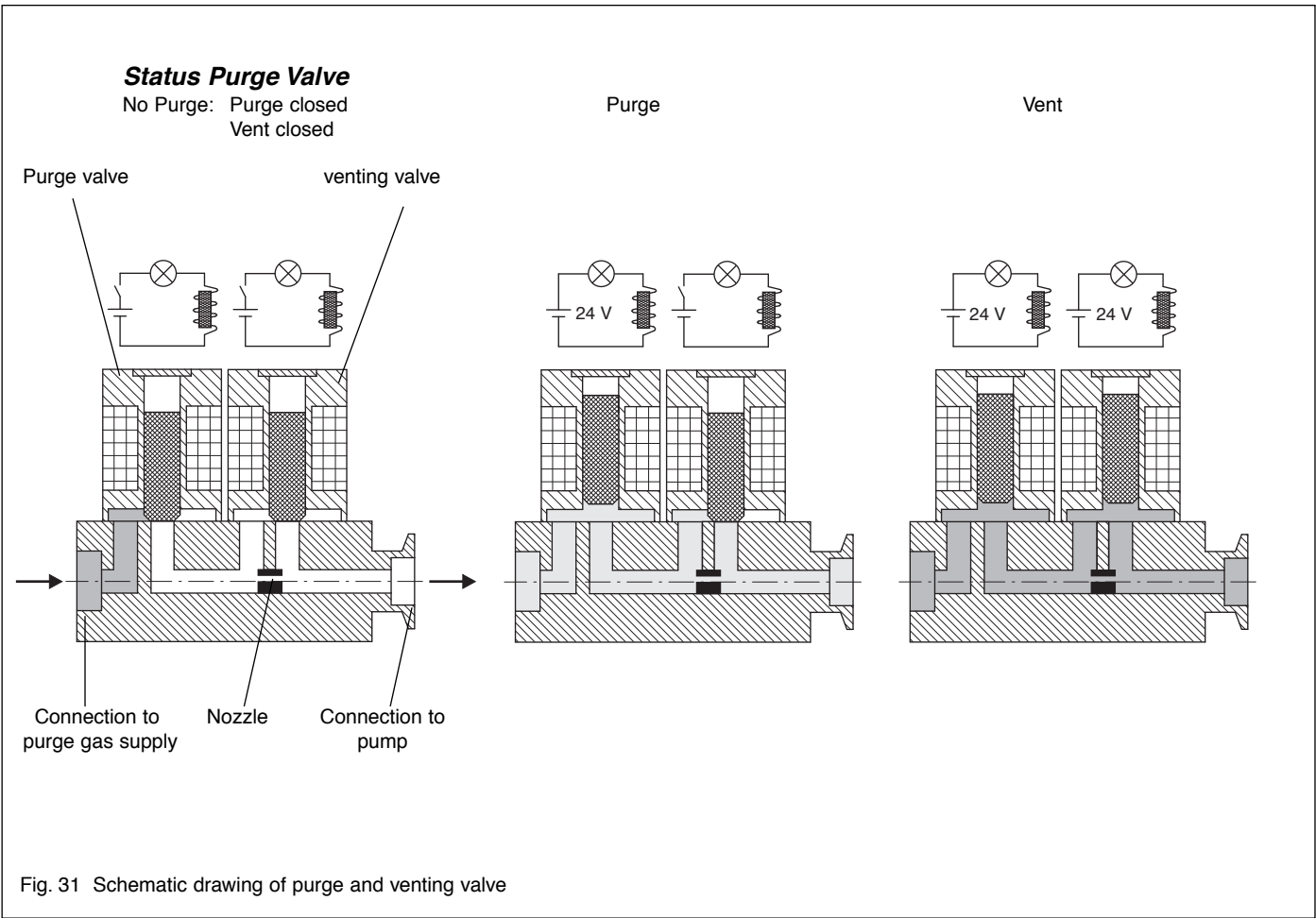

2.7 Connecting the purge gas

The MAG is equipped with a purge gas and venting valve. It is controlled by the MAG.DRIVE. Additional monitoring with a flow controller is not necessary.

Connect the purge gas and venting valve to the purge gas supply via a pressure reducer.

Connection: VCR Nut	1/4"
Purge gas connection pressure, abs.	1.2 - 2.0 bar
Purge gas: dry nitrogen, argon or similar	
Purge gas throughput at purge gas pressure 1.5 bar abs.	0.6 mbar·l·s ⁻¹ 36 sccm

With no voltage applied the purge gas and venting valve is closed.

The purge gas valve will be open when switching on the MAG.DRIVE. The red LED at the purge gas valve lights.

The venting valve can be opened via the control plug X1. The red LED at the venting valve lights when the valve is open. A blind-flanged pump will be vented within 1 minute via the open venting valve.

Warning



- Monitor the purge gas continuously. Insufficient purge gas flow can result in:
- Process gases entering the motor and bearing area of the MAG
 - Process gases escaping from the purge gas valve
 - Humidity entering the pump.

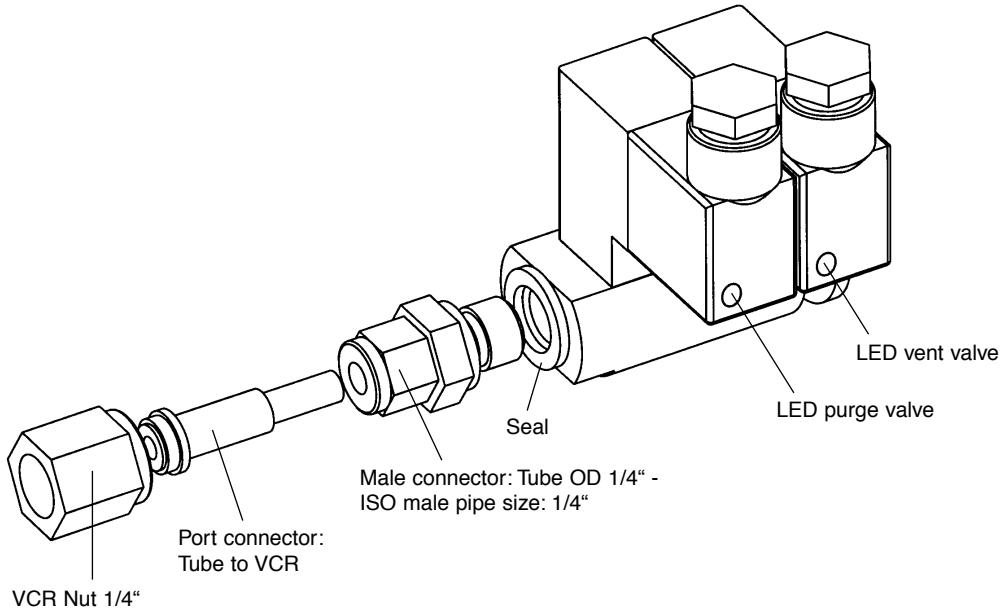

Fig. 32 Purge gas connection with connection kit

2.8 Installing the MAG.DRIVE

The converter can be installed in a 19" cabinet

Mounting depth: 350 mm + 130 mm for the connectors
on the rear side ($13\frac{3}{4}$ " + $5\frac{1}{8}$ ");

height: 5 height units ($8\frac{3}{4}$ ")

Caution

In order to guarantee sufficient cooling, there must be a minimum clearance of 1 height unit (44.2 mm) at the bottom and 1 height unit at the top. A fan assembly can be inserted. During operation the temperature of the ambient air must not exceed 40 °C for the MAG.DRIVE L and 45 °C for the MAG.DRIVE L2.

Warning



The pump may be operated only with a suitable frequency converter and a suitable connector cable.

Peak voltages of up to 130 V may be present at the connector line between the frequency converter and the pump; mains voltage is present at the heater.

Route all cables so as to protect them from damage.

The protection rating for the connectors is IP 30.

Do not expose the pump, the frequency converter or the connections to dripping water.

Install 16 A fuses for the converter.

Warning



Only adequately trained electrical/electronic personnel may connect-up the equipment in accordance with valid IEC (international), EN (European) and/or national guidelines, or under their management and supervision.

Caution

The connecting cables between the converters and pump may only be inserted or removed when the converter is switched off or is isolated from the line supply. If a connector is inserted or withdrawn when the converter is switched on, the converter and the pump could be damaged or destroyed!

Warning



Hazardous voltages are present inside the converter. Death or severe injury can occur if you come into contact with these hazardous voltages. Before opening the converter, isolate the converter from the line supply, and lock the switch so that it cannot be accidentally switched on again.

Installation instructions to maintain EMC

The MAG.DRIVE L2 complies with the Electromagnetic Compatibility (EMC) Directives of the EC. In order to maintain this the following installation instructions must be observed:

- The housing must be connected to a good ground connection (e.g. mounting rack) using a large cross section (e.g. 1.5 mm²) cable which should be as short as possible. The PE connection is located on the rear panel.
- To connect the pump to the converter the prescribed Leybold cables must be used.
- A shielded cable must be used for the connections to the terminal strip X33. The shield should be connected to ground to a low-impedance connection.
- The connection cables to the analog interface (control plug X1) and to the serial interfaces (connectors X7.1 and X7.2) must be shielded. The shields must be connected to the metal housings of the SUB-D-connector and SUB-D-socket.

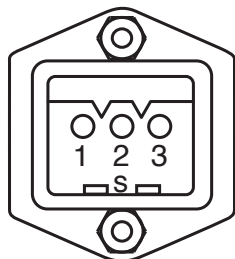

1 = Phase L
 2 = Not assigned
 3 = Neutral N
 S = PE

Fig. 33 Connector assignment X10, supply connection

2.8.1 Power supply connection X10

The converter is ready to be connected to line supply voltages between 200-240 V 50/60 Hz. The connection is established using the power cable supplied, which is inserted at connector X10 at the rear of the converter.

Caution

The converter will be damaged if it is operated with the incorrect supply voltage.

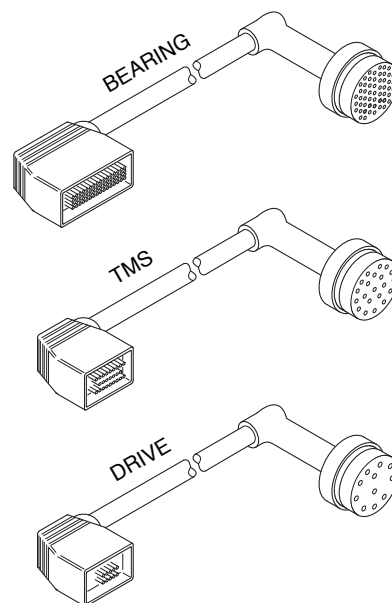

Fig. 34 Cable set with bended plugs;
 cable set with straight plugs similar

2.8.2 Pump connection

Connect the converter (X26) to the pump motor connection (X25) using the DRIVE connecting cable.

Connect the converter (X24) to the magnetic bearing connection of the pump (X23) using the BEARING connecting cable.

Connect the converter (X31) to the TMS connection of the pump (X30) using the TMS connecting cable.

Also refer to Fig. 35 or 36.

Make sure that you have fixed all cables properly by using the clamps fixed to the converter.

Mounting position and cable length

If the pump is mounted in a **vertical** position (intake flange up or down) the permissible length of the pump-converter cables is **3 to 20 meters**.

If the pump is mounted in a **horizontal** position the permissible length of the pump-converter cables is **3 meter**.

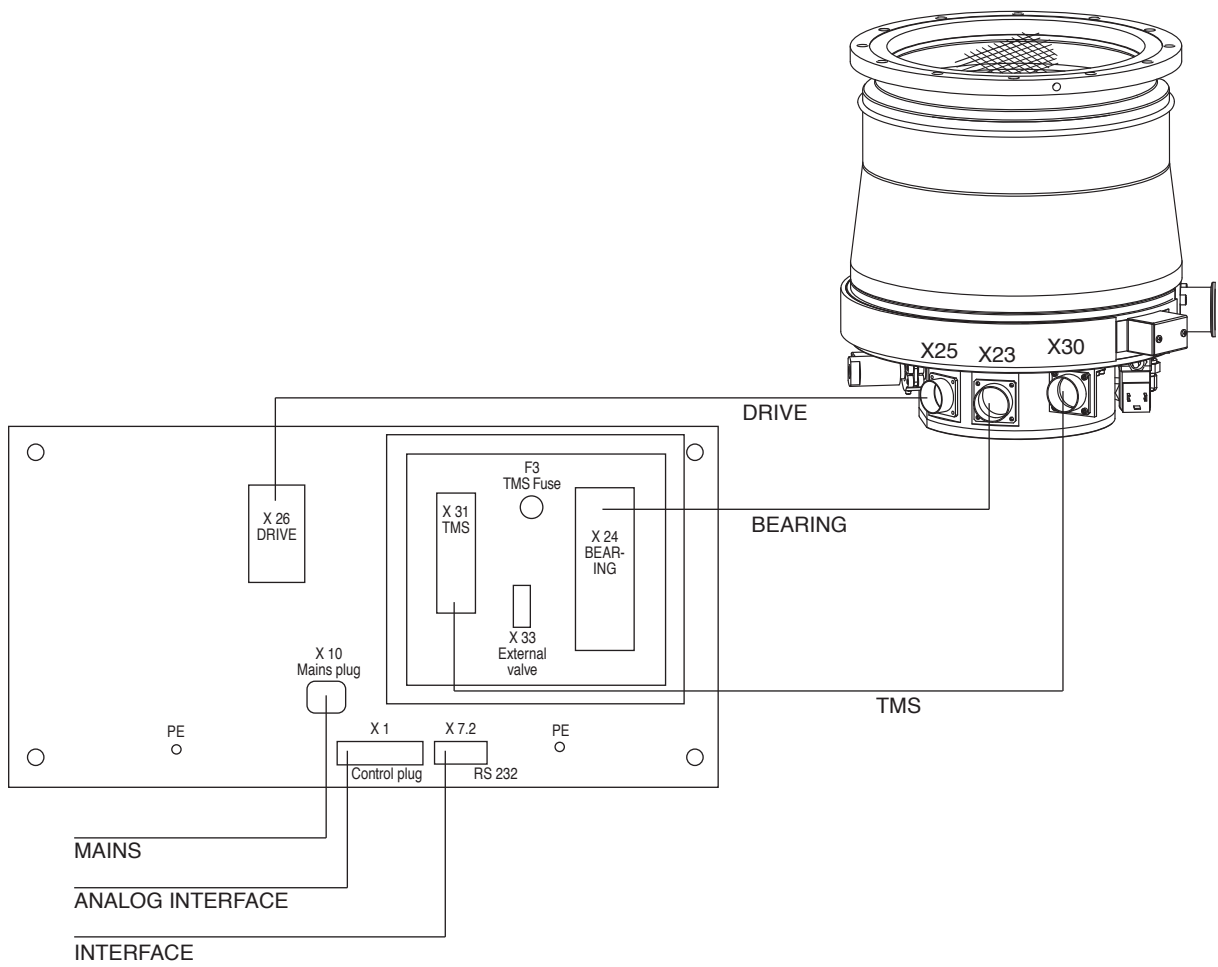

Fig. 35 Block wiring diagram for MAG.DRIVE L

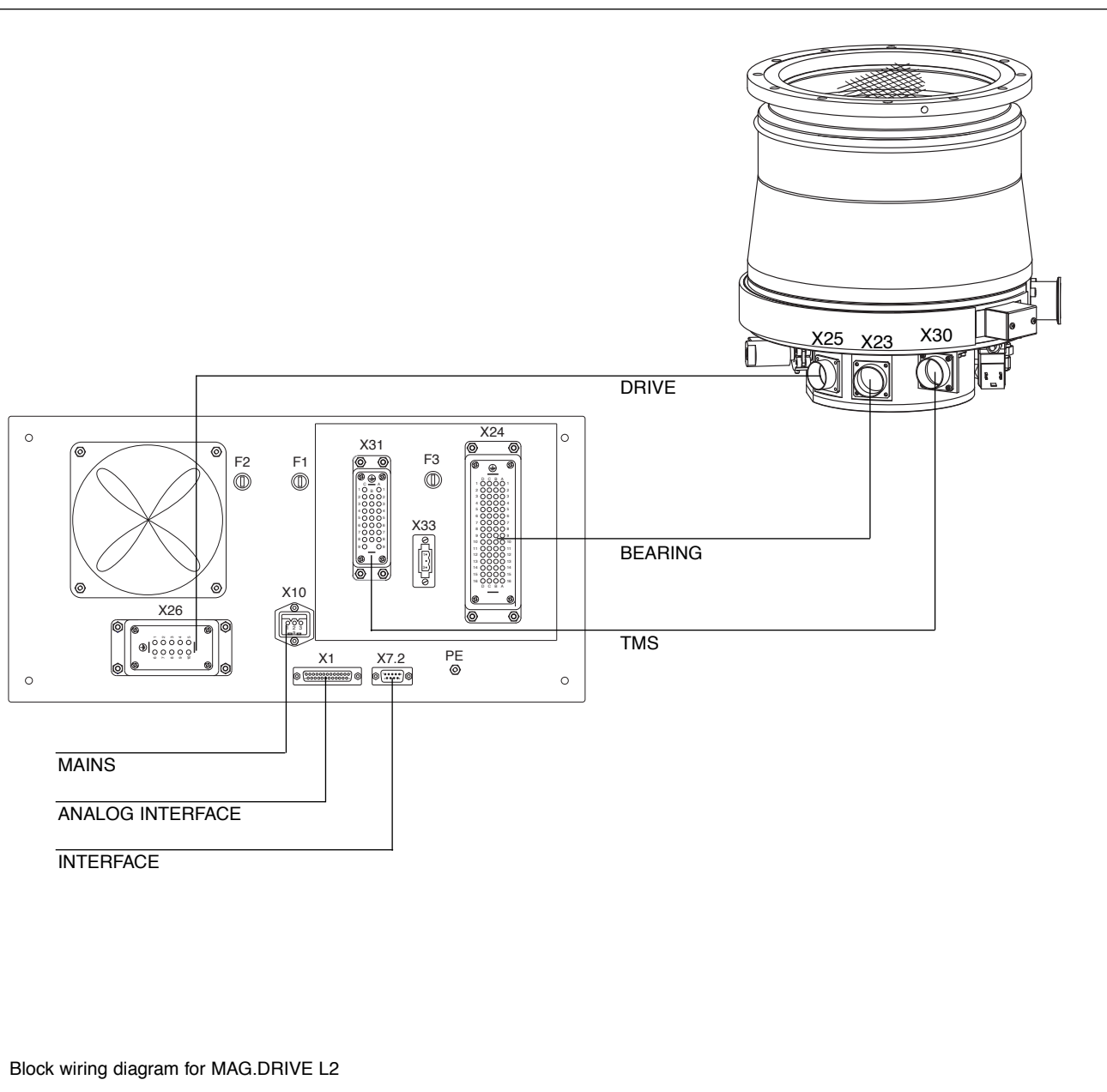
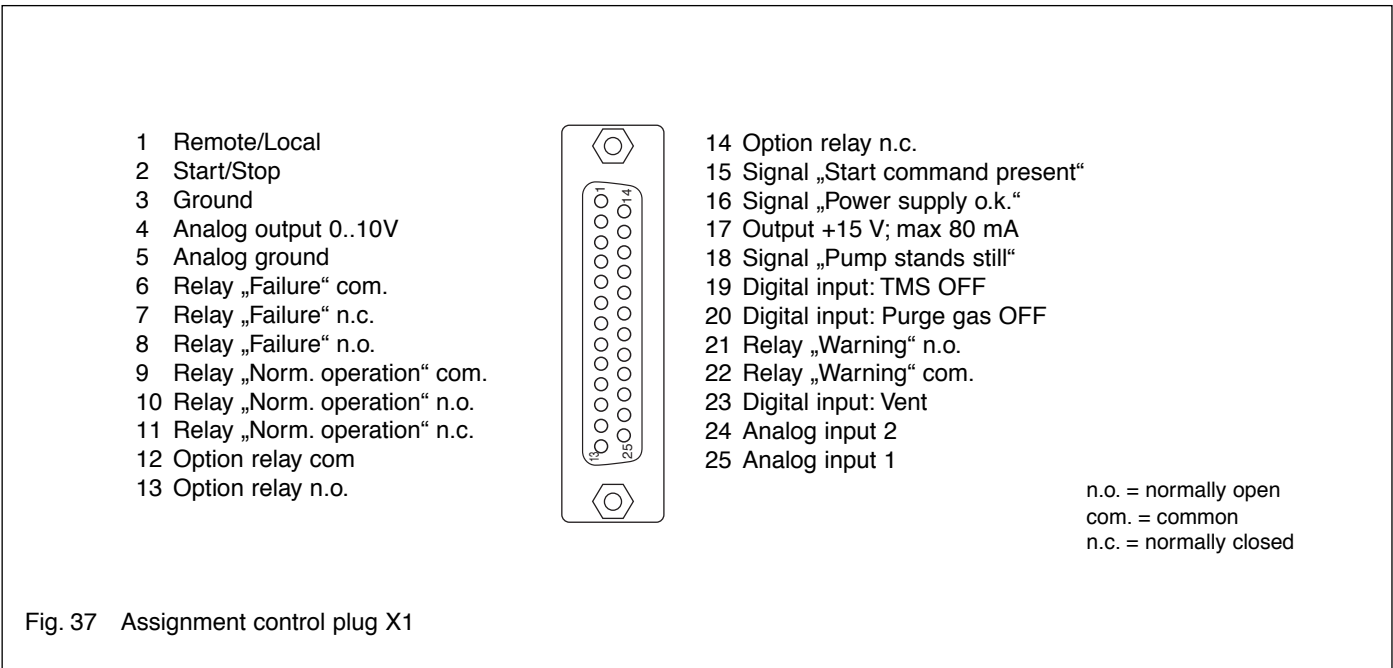

Fig. 36 Block wiring diagram for MAG.DRIVE L2



2.8.3 Control plug X1

Relay outputs

The MAG.DRIVE L converter has 4 relay outputs. Three relay outputs are permanently assigned a signal.

Normal operation	(changeover contact)
Failure	(changeover contact)
Warning	(NO contact)

The option relay (changeover contact) can output one of the following signals:

- Threshold motor temperature reached (only MAG.DRIVE L)
- Threshold bearing temperature reached (only MAG.DRIVE L2)
- Threshold motor current reached
- Threshold frequency reached
- No cooling water
- No purge gas
- TMS temperature OK
- Vent

The selection of signals for the option relay and the adjustment of their thresholds can be achieved via the operator control menu; see Sections 4.5.2 or 4.6.2.

Signaling outputs

Open-collector outputs are available to signal

- start command applied
- power supply O.K.
- pump standstill

at control plug X1. The outputs can have a maximum load of 15 V DC, 80 mA.

Analog output

The converter has an analog output which provides an analog signal (0..10 V) with a 10-bit resolution. The analog output function can be alternatively used to output

- motor current
- actual frequency
- motor temperature
- rotor displacement signals (PW24, PV13, PZ12)

The output value can be increased or reduced by a scaling factor; refer to the operator control menu “Scaling”; see Sections 4.5.2 and 4.6.2 Settings Converter.

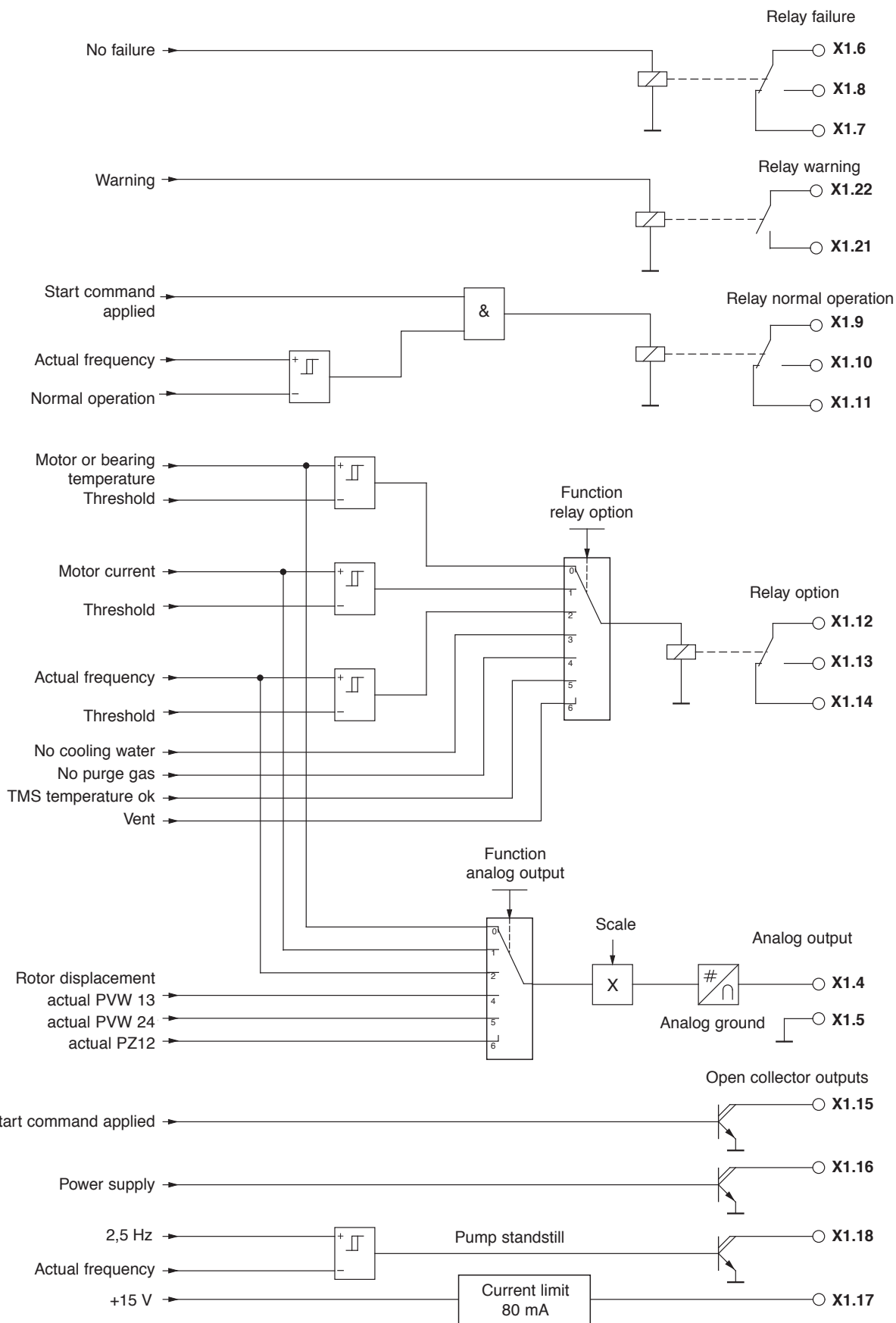

Fig. 38 Function diagram outputs

Analog inputs

The converter has two analog inputs with a 10-bit resolution.

Input signal: 0...10V standard
 4...20mA on request

A supplementary function can be set for analog input 2 via the operator control menu; see Sections 4.5.2 or 4.6.2:

No function: The input signal can be output via the serial interface.

Frequency setpoint: In addition to the function described above, the drive frequency setpoint is entered via analog input 2.

Analog ground

Analog ground X1.5 is the reference ground for the analog output as well as for the analog inputs.

Digital inputs

The converter has 3 digital inputs with the following functions:

- TMS OFF
- Purge gas OFF
- Vent ON

The functions are active if an High signal (15 V) is connected at the digital input.

2.8.4 Interface connector

A 9-pin sub-D socket is provided at the front panel and a 9-pin sub-D connector at the rear panel to connect a higher-level open-loop control and monitoring unit or a PC with the MAG.WIN operator control program.

The front connector X7.1 is assigned the serial interface RS232. If the front connector is to be used, to select connector X7.1, pin 1 must be connected to pin 5 (signal ground). To upload the software, pin 4 (boot) must be connected with pin 5 (signal ground).

The rear connector X7.2 is assigned with the serial RS232 interface.

Further information on the serial interface and the interface protocol to be used are provided in the optional manual „Serial interface MAG.DRIVE”.

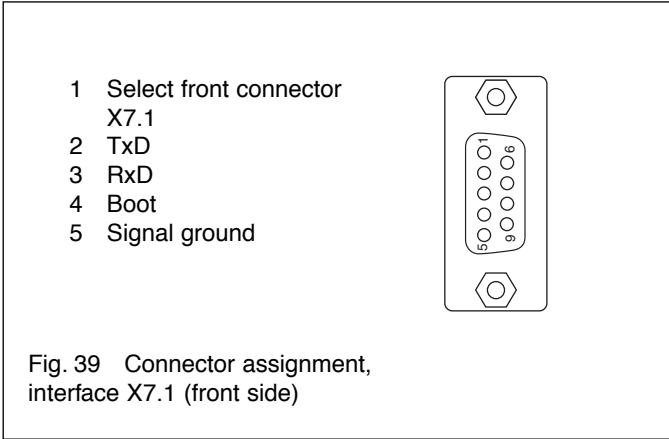

Fig. 39 Connector assignment, interface X7.1 (front side)

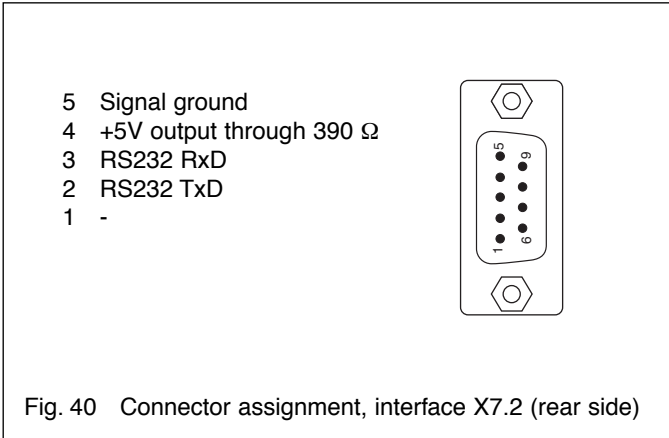

Fig. 40 Connector assignment, interface X7.2 (rear side)

2.8.5 Connection X33

The internal +24 V supply voltage can be accessed for external loads at connector X33; for example, to connect relays or solenoid valves. The output is short-circuit-proof and the output current is limited to 300 mA.

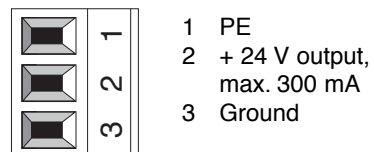

Fig. 41 Connector assignment X33, supply voltage

3 Operation

This Section describes the normal operation of the MAG pumping system

- via the front panel keys START and STOP,
- with pump and converter in the state of delivery from Leybold, and
- if no failure occurs.

If you want to operate the pumping system differently or if you want more background information about the pumping system operation refer to the following Sections:

- Explanation of the front panel keys 4.1
- Explanation of the display 4.2
- Operate the pump via remote control 4.3
- Explanation of the displayed operating statuses 4.4
- Change pump parameters via the operating menu 4.5 or 4.6
- Explanation of the temperature management system 4.7
- A failure message is displayed 6

3.1 Switching on

- Switch on the MAG.DRIVE. The display reads

Ready	
0.0 A	0 Hz

If the pump has the optional TMS (including e.g. the red heater band) the heater will be activated. The setpoint temperature will be reached within 30 - 60 minutes depending on cooling water temperature and flow.

In case of corresponding connection the backing pump will be activated when switching on the MAG.DRIVE.

- Open the purge gas supply.
- Open the cooling water supply.
- Press the START button.

The pump runs-up.

Acceleration	
20.0 A	250 Hz

is displayed until the frequency setpoint has been reached. Then

Normal Operation	
1.0 A	480 Hz

is displayed.

The backing pump and the MAG can be switched on simultaneously. In such a situation the MAG serves from the very outset as an effective baffle.

Do not suddenly expose the MAG to an already evacuated vacuum chamber. The pressure surge may cause the rotor to make contact with the touch-down bearings. This will cause increased wear.

The pump may make noise during the run-up and run-down phases. This has neither an influence on the pump nor on the process.

3.2 Operation

The magnetic bearing in the MAG are immune to wear. In addition to the magnetic bearings, the MAG is equipped with touch-down bearings which protect the rotor against mechanical contact with the stator if the pump is subjected to external shock loading or when the pump is switched off. These touch-down bearings have a limited service life. Please observe the following in order to obtain maximum service life.

- Avoid shock and vibrations when the pump is running. Shocks perpendicular to the rotation axis are particularly harmful. If the pump appears to be running in the mechanical bearings continuously it is switched off.
- Avoid frequent run up and down. The converter may overheat. You may run up and down the pump twice immediately after each other.
- Do not disconnect the MAG and MAG.DRIVE while they are operating. If MAG and MAG.DRIVE have been disconnected accidentally do not re-connect them while the MAG is operating.

Warning



Monitor the purge gas continuously. Insufficient purge gas flow can result in:

- Process gases entering the motor and bearing area of the MAG
- Process gases escaping from the purge gas valve
- Humidity entering the pump.



Refer to Section 2.7.



MAG with heating collar:

Warning



The heating collar will be hot during operation. Burn hazard!

3.3 Switching off

The MAG.DRIVE controls the venting automatically provided purge gas is connected to the MAG and the MAG.DRIVE is programmed correspondingly („Vent on“).

Caution

The values shown in the pressure rise curve must be maintained; see Fig. 42.

Caution

Do not stop the MAG with the mains. Use the STOP key.

Switching off the mains while the pump is running will wear out the touch down bearings.

- Press the STOP key.

Deceleration	
20.0 A	400 Hz

will be displayed. When the display reads

Ready	
0.0 A	0 Hz

the pump has come to a standstill.

- Close the cooling water supply when the pump is switched off in order to avoid condensate formation in the pump.

The backing pump may be switched off once the MAG has stopped.

If the MAG has been used for pumping corrosive gases it should be purged with dry nitrogen for one hour before switching off. During down times of the system take care that neither ambient air nor cleaning agents enter the pump.

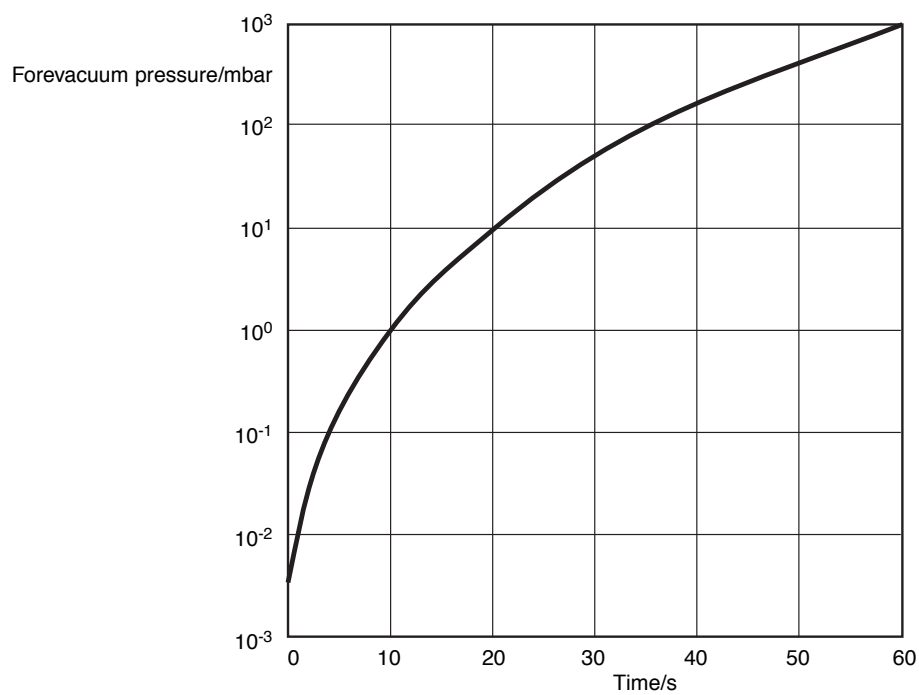

Fig. 42 Curve for safe venting of the MAG; pressure rise as a function of venting time

4 Converter Control

4.1 Functions of the front panel keys

- Starts the pump (only possible if there is no fault). The start key is only active if the user is in the basic menu or in the operating display.



- Returns to the operating display from any point in the programming menu.
- Stop when the pump is operational. The pump is braked down to < 1 Hz.
- Acknowledges a failure after the cause of the failure has been removed.



- Selects a sub-menu
- Acknowledges a modified value



- Changes from the operating display into the programming menu
- Selects the programming menu in the main menu

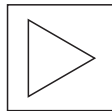

- Returns to the last main menu in the programming menu

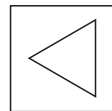

- Increases a parameter value or proceeds to the next option

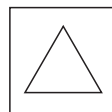

- Lowers a parameter value or returns to the previous option

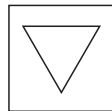

4.2 Operating display

All operating states, warning and failure are displayed on the display and three lamps on the front side of the converter.

If a critical operating status occurs, e.g. "Warning Temp. Pump", this warning is displayed, alternating with the operating display.

Plain text display

- 1st line: Operating status
- 2nd line: Motor current / Actual frequency / (TMS status code for MAG.DRIVE L2)

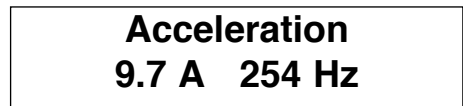

or

- 1st line: Failure message
- 2nd line: Failure cause



TMS status code (only for MAG.DRIVE L2)

No.	Code	Description
1	H	Heating pump (range below $T_{set} - 5K$)
2	H O K	Temp. TMS ok, heater ON (range $T_{set} - 5K$ to T_{set})
3	O K	Temp. TMS ok (range $T_{set} \pm 2K$)
4	C O K	Temp. TMS ok, cooling ON (range $T_{set} + 5K$ to T_{set})
5	W	Warning Temp. TMS (Temp. > $T_{set} + 5K$)
	O F F	TMS cancelled via control plug X1

see also Section 4.7.2 „TMS for the MAG.DRIVE L2“

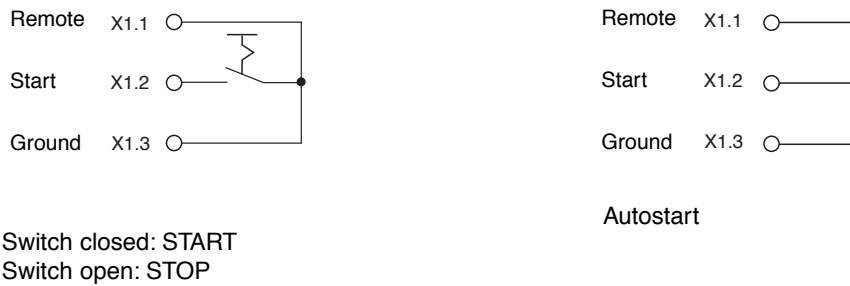

Fig. 43 Connecting-up example remote control

Significance of the lamps



COM (green)

Is lit if communication has been established via the interface.

STATUS (green/red)

- Red, steady light = Failure
- Red, flashing = Warning
- Green, flashing (slow) = Start delay, Acceleration
- Green, flashing (fast) = Deceleration, Kinetic buffering
- Green, steady light = Normal operation

MAINS (green)

This lamp is lit if the power is switched-on, and all of the supply voltages for operation are available.

Flashes when the power fails as long as the power supply voltages in the converter are maintained by the kinetic buffering.

4.3 Remote control

The converter permits 3 operating modes. They can be selected via contact X1.1 of the control connector at the rear panel of the converter or via the serial interface. Operating mode 0 is automatically selected after the line supply voltage has been applied.

Operating mode 0

The pump can be switched-on or off using the START/STOP keys or via control connector X1. The reference frequency can be selected in the operating menu.

- X1.1 not connected = Start/Stop via the operator control panel
- Jumper X1.1-X1.3 = Start/Stop via control input X1.2

Operating mode 1

This operating mode can only be selected via the serial interface.

The pump can only be started and stopped via the serial interface.

The frequency setpoint can only be changed via the serial interface, e.g. from MAG.WIN

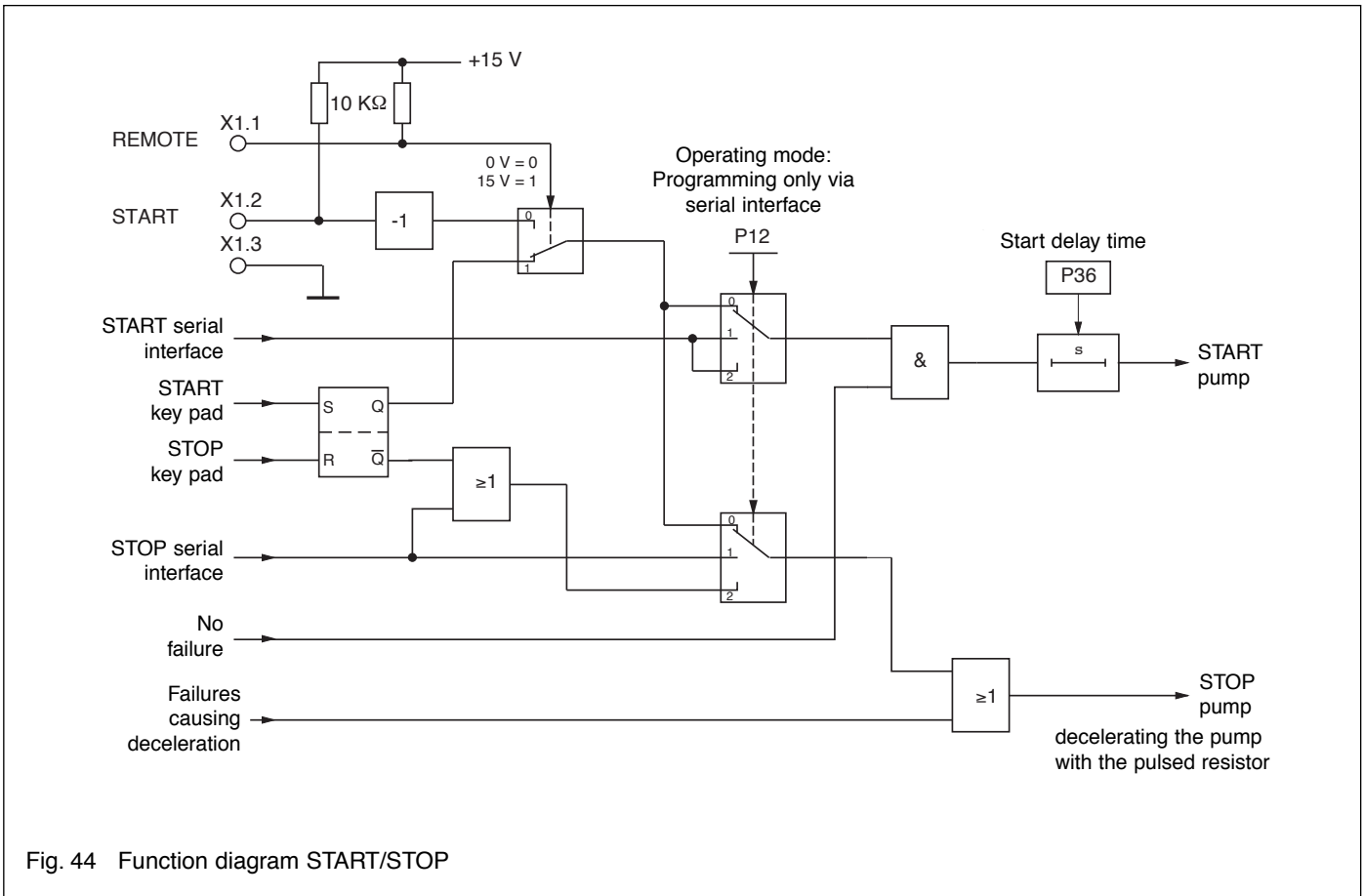

Fig. 44 Function diagram START/STOP

Operating mode 2

This operating mode can only be set via the serial interface.

The pump can be switched-off via the keyboard, but it cannot be started via the keyboard.

The frequency setpoint can only be changed via the serial interface, e.g. from MAG.WIN.

Automatic starting after the power has been connected

Connect contacts X1.1, X1.2 and X1.3 with one another. The converter starts automatically when the power is applied.

4.4 Operating statuses

Switch-On Guard

The converter goes into the “Switch On Guard” operating status after the power is switched on and after initialization. If there is no warning or failure, it changes over into the “Ready” condition.

After a failure has been acknowledged, the converter goes into the “Switch On Guard” operating status. The failure must be acknowledged a second time, so that it then goes into the “Ready” condition.

Ready

The converter is ready and waits for the START command. All parameters can be interrogated or changed via the operator control panel or the serial interface.

The basic menu parameters (refer to 4.5/4.6, operating menu) can be scanned via the operator control panel.

Acceleration

The pump continuously accelerates with the maximum current. The acceleration time is monitored to ensure that it lies within a programmed value (refer to the menu “settings pump/max. Accel. Time”). If the converter hasn't reached the normal operating mode during the monitoring time, then it is shutdown with the failure message „max. Accel. Time”.

Normal operation

After a programmable frequency threshold has been reached (refer to the menu “settings pump/Normal Operation”), the converter goes into the normal operation mode but the pump continues to accelerate up to the frequency setpoint.

Maximum power or Overload

„Maximum power“ for MAG.DRIVE L or „Overload“ for MAG.DRIVE L2.

The speed is continuously monitored and controlled. If the speed, even at maximum current, cannot be held at the setpoint, as a result of external influences, e.g. excessive gas intake, the speed reduces until the converter goes into the „max. power” or „Overload“ operating condition when the programmable frequency threshold is fallen below (refer to the menu “settings pump/Normal Operation”). The acceleration time is restarted. If the converter hasn't gone into the normal operating mode after the monitoring time, it is shutdown with the failure message „max. power time” or „Failure Overload Time”.

Kinetic buffering

If the power fails when the converter is switched on, the converter regenerates due to the pump up to a minimum frequency of < 170 Hz. When the power returns, the pump is again accelerated up to the frequency setpoint.

The acceleration time is now restarted. If the converter hasn't gone into the normal operating mode after the monitoring time, it is shutdown with the failure message „max. Accel. Time” .

Deceleration

After a stop command, the pump is braked down to a speed < 1 Hz as quickly as possible. A brake resistor is integrated into the converter which converts the regenerative energy into heat.

Failure

The converter was shutdown with a failure message and waits for a failure acknowledgement after the failure has been removed. The failure type can be read from the display. The failure message can be acknowledged by depressing the STOP key or via the serial interface.

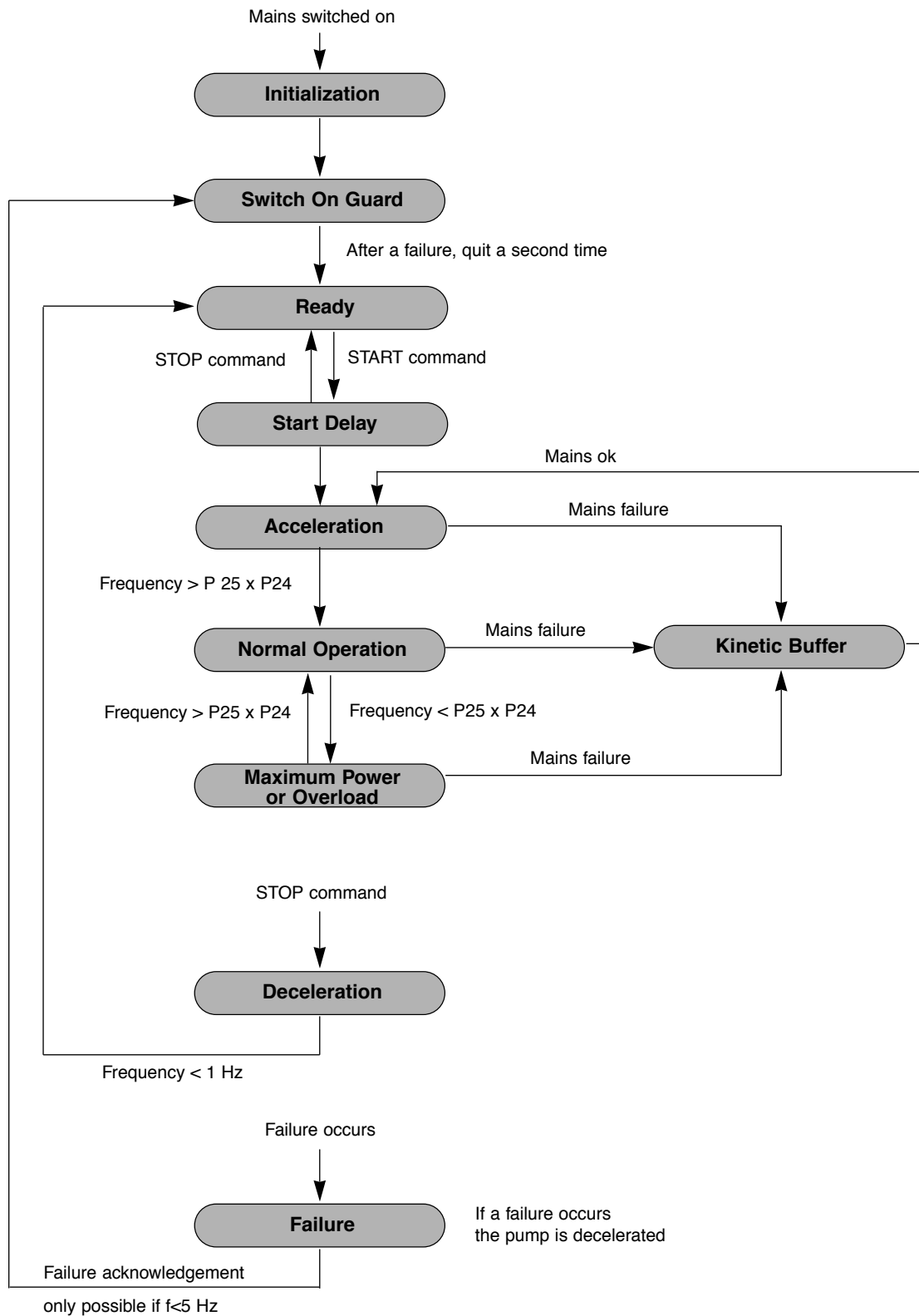

Parameter:
 P24 = Frequency setpoint
 P25 = Factor normal operation

Fig 45 Diagram: Operation status

4.5 Operating menu for the MAG.DRIVE L

4.5.1 Basic menu

Menu item	Description	Adjustable value / option				Unit	Access
		min. value	max. value	standard			
Ready	Operating display	-	-	-	-	-	-
Setpoint	Sets the speed for operation	0	480	480	Hz	r/w	
Pump life	Total operating hours of the pump	actual value			h	r	
Temp. Motor	Motor temperature	actual value			°C	r	
Temp. Converter	Temperature of the power electronic	actual value			°C	r	
Temp. Pump	Temperature of the magnetic bearing	actual value			°C	r	
Temp. TCU	Temperature of the Temperature Management System	actual value			°C	r	
Temp. Cooling	Cooling water temperature	actual value			°C	r	
Diff. pressure	Difference pressure Only active at pump models with purge valve flow control (MCF, MCTF)	actual value			mbar	r	
actual PVW 13	Rotor displacement in the magnetic bearing plane VW13	actual value			%	r	
actual PVW 24	Rotor displacement in the magnetic bearing plane VW24	actual value			%	r	
actual PZ 12	Rotor displacement in the magnetic bearing axis Z12	actual value			%	r	
power	Power consumption of the drive	actual value			W	r	

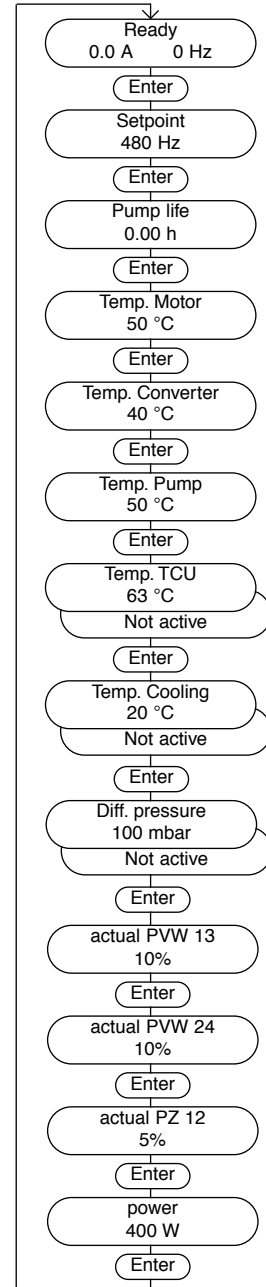

r (read) = value can **only** be read

r /w (read/write) = value can be read and written

4.5.2 Settings converter

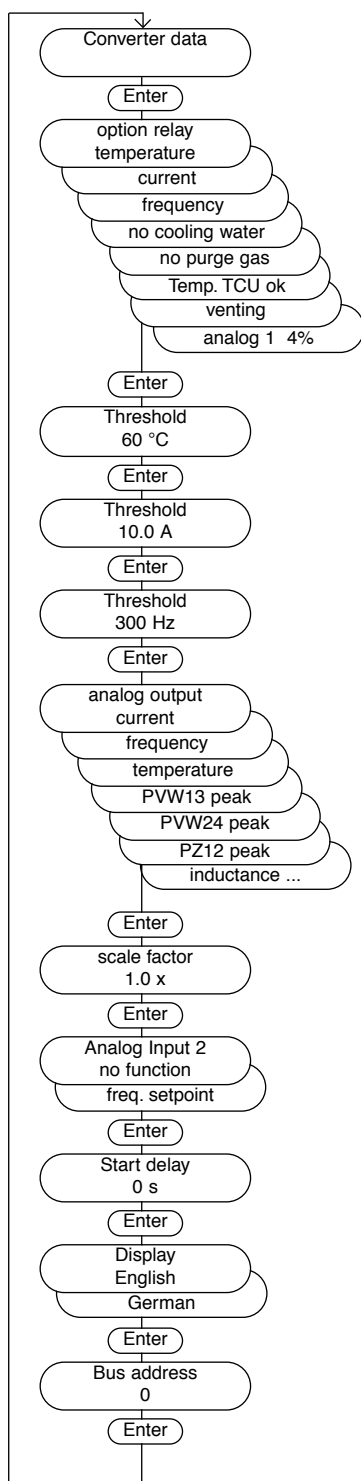

Menu item	Description	Adjustable value / option				Access
		min. value	max. value	standard	Unit	
Option Relay	Relay with change -over contact; the operator can select one of the functions described the thresholds are adjusted in the next three menu items	Threshold motor temperature reached °C Threshold motor current reached A Threshold frequency reached Hz No cooling water - no purge gas - TMS temperature o.k. - Vent - „analog1 4%“ not used				r/w
Threshold	Threshold motor temp. for option relay	0	100	60	°C	r/w
Threshold	Threshold motor current for option relay	0	20	10	A	r/w
Threshold	Threshold frequency for option relay	0	480	300	Hz	r/w
analog output	Analog output 0...10V; the operator can select one of the functions described	Motor current; 20 A = 10Vxscale factor V Act. frequency ; 500 Hz = 10Vxscale factor V Bearing temp. ; 100 °C = 10Vxscale factor V Actual PVW13; 100% = 10Vxscale factor V Actual PVW24; 100% = 10Vxscale factor V Actual PZ12; 100% = 10Vxscale factor V „inductance“ not used				r/w
scale factor	Scale factor for the analog output	0	2	1	-	r/w
Analog Input 2	Analog input 0...10V ; optionally frequency setpoint via analog input 2 (10V = max. frequency setpoint)	No function - Function frequency setpoint -				r/w
Start delay	Waiting time between start command and acceleration	0	1200	0	s	r/w
Display	Display language	English - German -				r/w
Bus adress	Bus adress for the converter for operation via serial interface RS232	0	31	0	-	r/w

r (read) = value can **only** be read
 r /w (read/write) = value can be read and written

4.5.3 Settings pump

Menu item	Description	Adjustable value / option				Access
		min. value	max. value	standard	Unit	
Normal operation	Threshold for normal operation corresponding to the frequency setpoint	35	99	95	%	r/w
max. accel. time	Monitor time for acceleration and overload	600	3600	1000	s	r/w
Motor current	Limits the maximum motor current; used to limit the pump rotor temperature. !!! See warning below!!!	5	100	65	%	r/w
Pump Type	Displays the installed pump type !!! Do not change the pump setting!!!	Installed pump type			-	r/w

Warning



Setting the motor current to more than 65% may result in rotor overheating.
Setting the motor current to more than 65% or changing the pump setting without permission from Leybold voids the warranty.

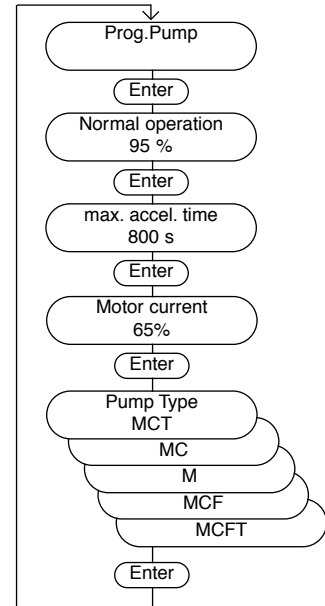

4.5.4 Settings active magnetic bearing

Menu item	Description	Adjustable value / option				Access
		min. value	max. value	standard	Unit	
ident.magn.bear.	Code to identify AMB type	actual value			-	r
Emerg. bearing	Counts	actual value			-	r
Emerg. bearing	Time	actual value			s	r

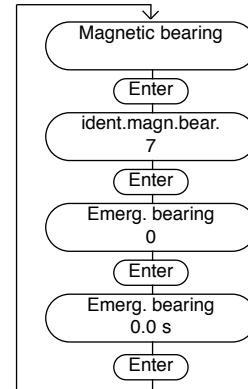

r (read) = value can **only** be read
r /w (read/write) = value can be read and written

4.5.5 Settings temperature management system

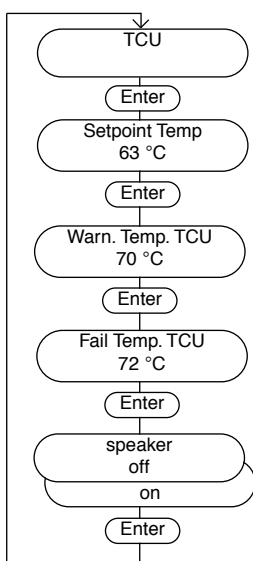

Menu item	Description	Adjustable value / option				Unit	Access
		min. value	max. value	standard			
Setpoint Temp.	Setpoint Temperature Management System	20	75	63	°C	r/w	
Warn.Temp. TCU	Warning temperature Temperature Management System	0	85	70	°C	r/w	
FailTemp. TCU	Shutdown temperature Temperature Management System	0	100	72	°C	r/w	
speaker	Intermittent = warning Continuous = failure		off on		- -	r/w	

4.5.6 Settings purge / vent

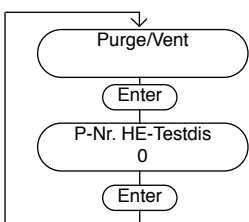

Menu item	Description	Adjustable value / option				Unit	Access
		min. value	max. value	standard			
P-Nr. HE Testdis	Not used						

r (read) = value can **only** be read
 r /w (read/write) = value can be read and written

4.5.7 Total view of the menu

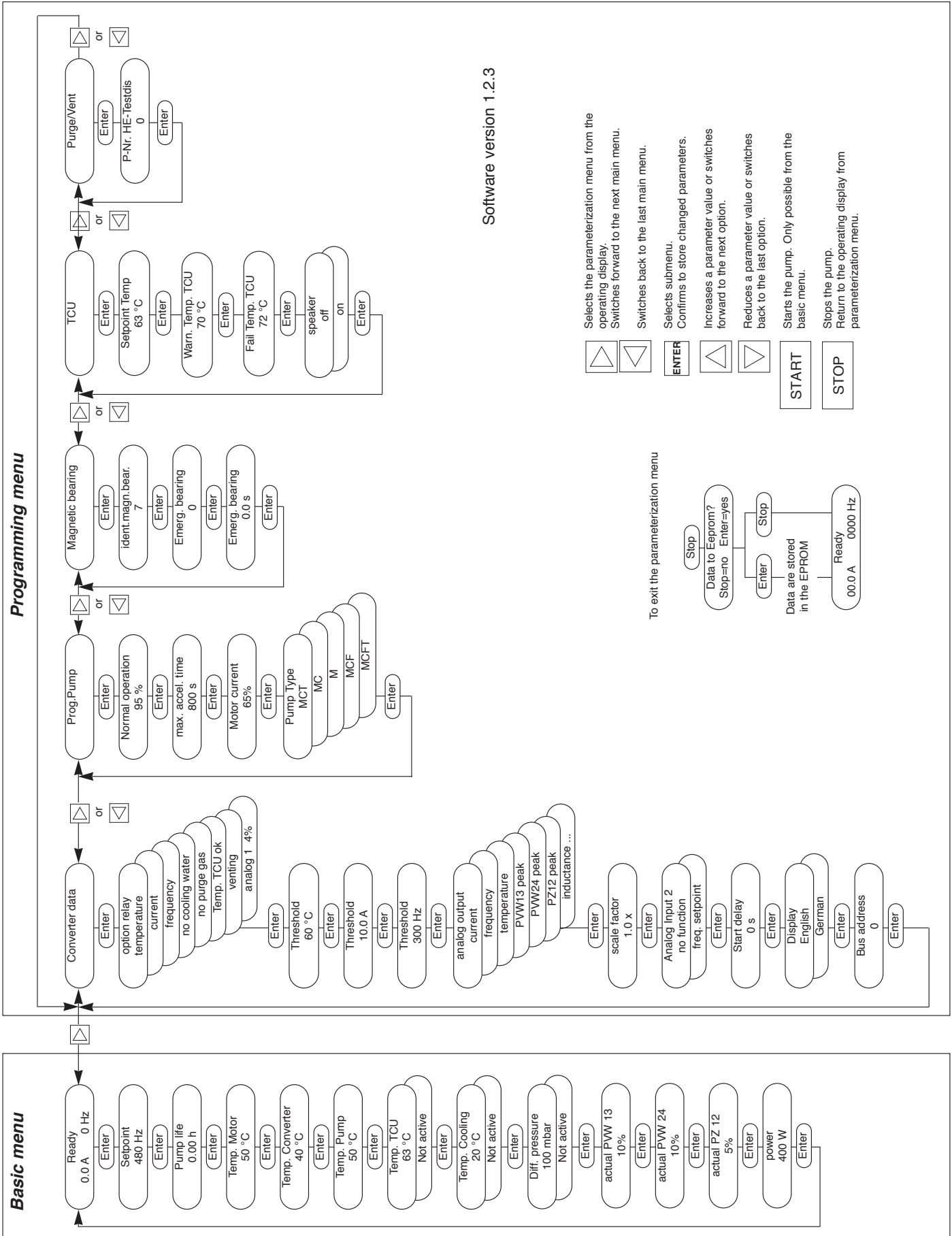

4.6 Operating menu for the MAG.DRIVE L2

4.6.1 Basic menu

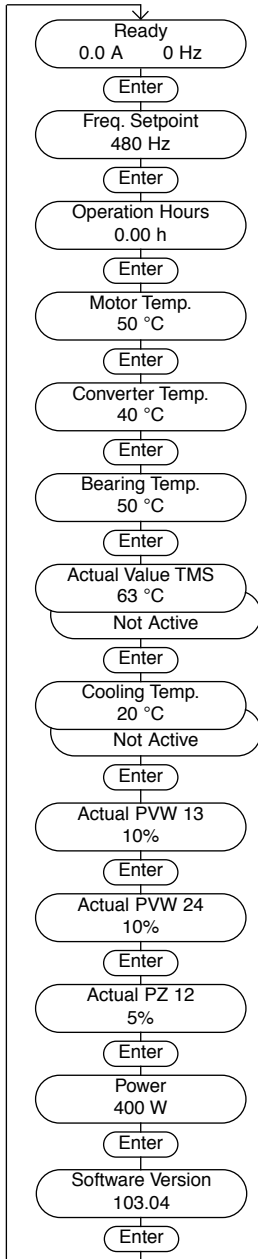

Menu item	Description	Adjustable value / option				Unit	Access
		min. value	max. value	standard			
Ready	Operating display	-	-	-	-	-	-
Freq. Setpoint	Sets the speed for operation	0	480	480	Hz	r/w	
Operation Hours	Total operating hours of the pump	actual value			h	r	
Motor Temp.	Motor temperature	actual value			°C	r	
Converter Temp.	Temperature of the power electronic	actual value			°C	r	
Bearing Temp.	Temperature of the magnetic bearing	actual value			°C	r	
Actual Value TMS	Temperature of the Temperature Management System	actual value			°C	r	
Cooling Temp.	Cooling water temperature	actual value			°C	r	
Actual PVW 13	Rotor displacement in the magnetic bearing plane VW13	actual value			%	r	
Actual PVW 24	Rotor displacement in the magnetic bearing plane VW24	actual value			%	r	
Actual PZ 12	Rotor displacement in the magnetic bearing axis Z12	actual value			%	r	
Power	Power consumption of the drive	actual value			W	r	
Software Version	Actual software version	actual value			-	r	

r (read) = value can **only** be read
 r /w (read/write) = value can be read and written

4.6.2 Settings converter

Menu item	Description	Adjustable value / option				Access	
		min. value	max. value	standard	Unit		
Option Relay	Relay with change -over contact; the operator can select one of the functions described the thresholds are adjusted in the next three menu items	Threshold bearing temperature reached				°C	r/w
		Threshold motor current reached				A	
		Threshold frequency reached				Hz	
		No cooling water				-	
		no purge gas				-	
		TMS temperature o.k.				-	
		Vent				-	
Threshold	Threshold bearing temp. for option relay	0	100	60	°C	r/w	
Threshold	Threshold motor current for option relay	0	20	10	A	r/w	
Threshold	Threshold frequency for option relay	0	480	300	Hz	r/w	
Analog Output	Analog output 0...10V; the operator can select one of the functions described	Motor current;				r/w	
		20 A = 10Vxscale factor					V
		Act. frequency ;					V
		500 Hz = 10Vxscale factor					
		Bearing temp.;					V
		100 °C = 10Vxscale factor					
		Actual PVW13;					V
100% = 10Vxscale factor							
Actual PVW24;				V			
100% = 10Vxscale factor							
Actual PZ12;				V			
100% = 10Vxscale factor							
Scale Factor	Scale factor for the analog output	0	2	1	-	r/w	
Analog Input 2	Analog input 0...10V ; optionally frequency setpoint via analog input 2 (10V = max. frequency setpoint)	No function				-	r/w
		Function frequency setpoint				-	
Start Delay	Waiting time between start command and acceleration	0	1200	0	s	r/w	
Display	Display language	English				-	r/w
		German				-	
Bus Adress	Bus adress for the converter by operation via serial interface RS232/485	0	31	0	-	r/w	
Acoustic Alarm	Intermittent = warning Continuous = failure	OFF				-	r/w
		ON				-	

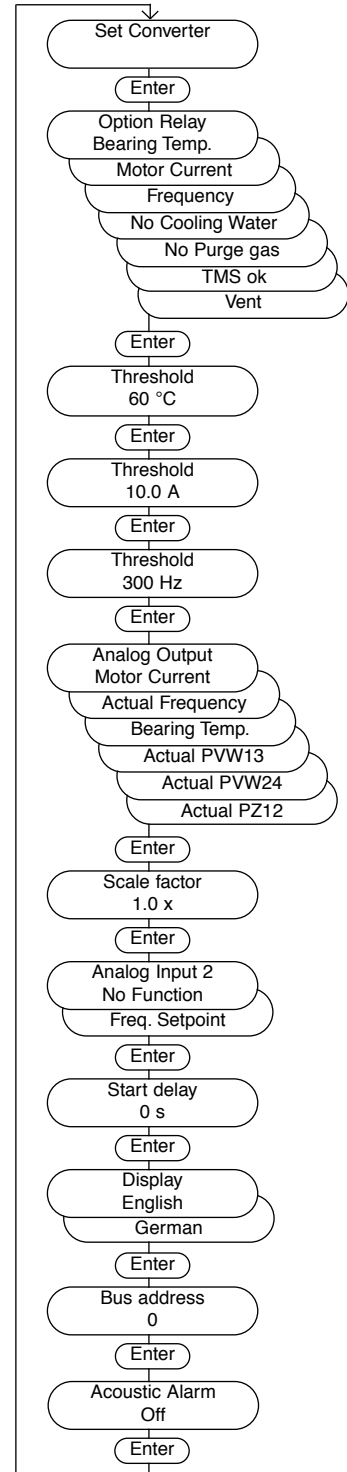

r (read) = value can **only** be read
r /w (read/write) = value can be read and written

4.6.3 Settings pump

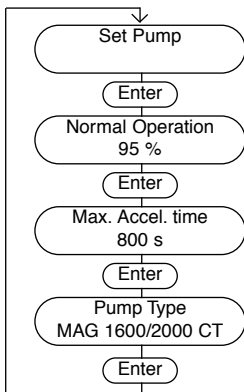

Menu item	Description	Adjustable value / option				Access
		min. value	max. value	standard	Unit	
Normal Operation	Threshold for normal operation corresponding to the frequency setpoint	35	99	95	%	r/w
Max. Accel. Time	Monitor time for acceleration and overload	600	3600	1000	s	r/w
Pump Type	Displays the installed pump type	Installed pump type			-	r

4.6.4 Settings temperature management system

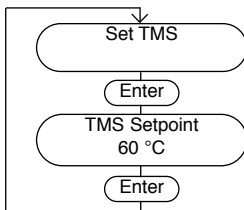

Menu item	Description	Adjustable value / option				Access
		min. value	max. value	standard	Unit	
TMS Setpoint	Setpoint Temperature-Management-System	20	70	63	°C	r/w

r (read) = value can **only** be read
 r /w (read/write) = value can be read and written

4.6.5 Settings purge / vent

Menu item	Description	Adjustable value / option				Access
		min. value	max. value	standard	Unit	
Purge / Vent	The operator can select one of the beside standing options for purge and vent	Purge OFF				r/w
		Purge ON				
		Controlling purge / vent via control plug X1				
Option P / V	Displays the factory installed option for purge and vent	Installed option		-	r	

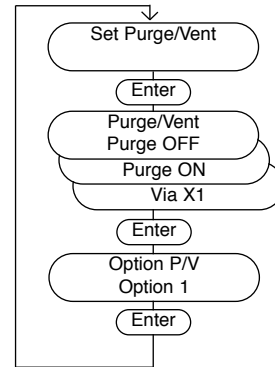

r (read) = value can **only** be read
 r/w (read/write) = value can be read and written

4.6.6 Total view of the menu

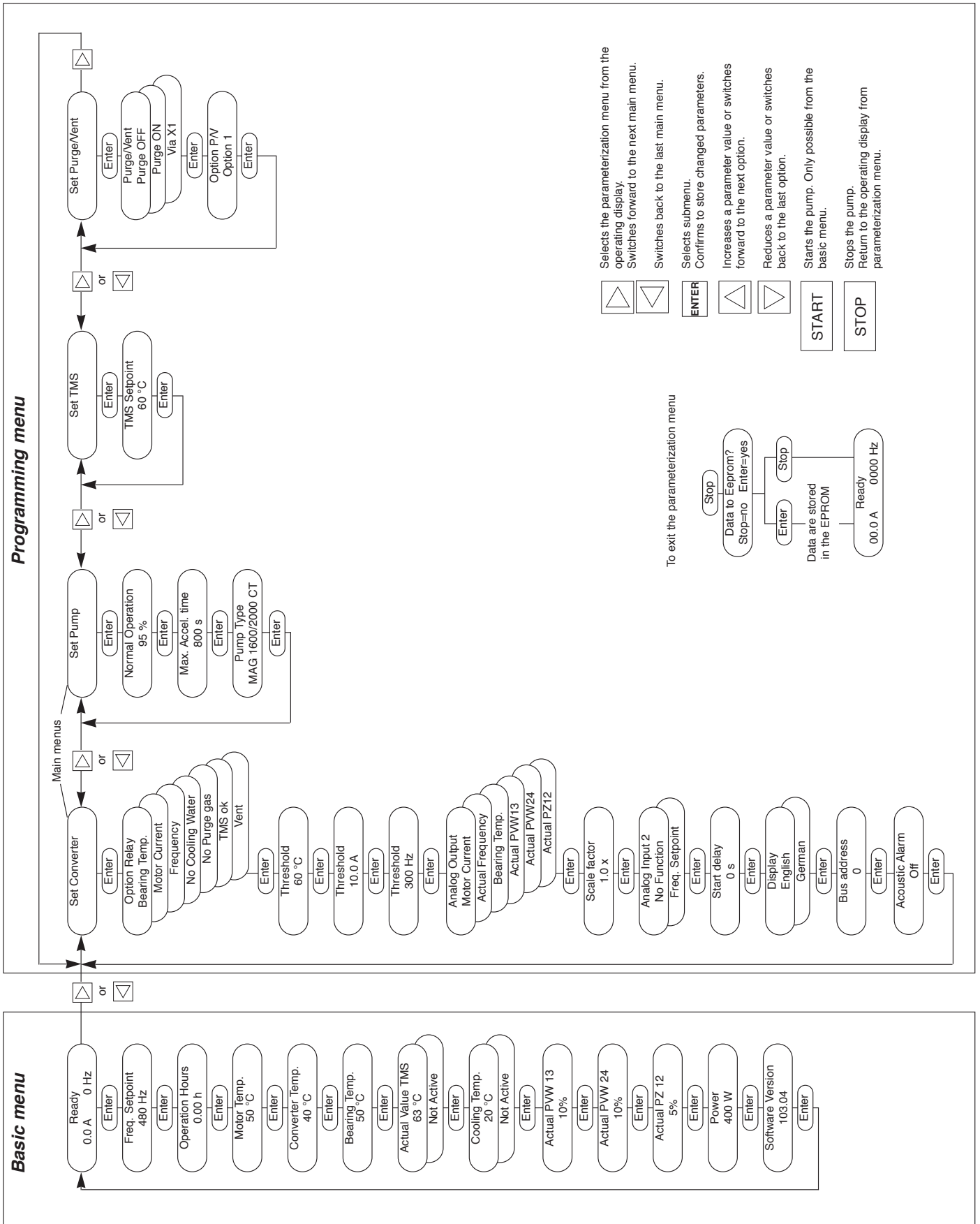

4.7. Temperature Management System

4.7.1 Temperature Management System for the MAG.DRIVE L

Function description

The TMS is only in function, when a MAG1600/2000 CT version is connected. The heater will be activated when the mains is switched on. The TMS (TCU) controls the heating and water cooling to maintain the pump at the specified setpoint temperature.

Settings

Principally the factory presettings will be used. The settings are saved in the pump's memory chip. Before changing any setpoint value request Leybold! The following parameters are programmable via the key panel or the serial interface when the pump stands still.

- Setpoint Temperature
- Warning Temperature
- Failure Temperature

For the settings refer to 4.5.5 Operating menu, Settings TMS.

Heat up

The setpoint temperature will be reached within 30 to 60 minutes depending on cooling water temperature and flow. If the flow is very high and the temperature low a high temperature setpoint might not be reached. For temperature sensitive applications observe the cooling water specifications (refer to section 1.6 Technical Data).

Actual temperature

The actual TMS is displayed on the operating display (refer to 4.5.1 Operating menu, Basic menu)

Signal TMS OK

If the actual TMS (TCU) temperature lies in the range $\pm 5K$ from the setpoint temperature, the TMS OK signal can be output via the option relay. The option relay must be programmed for this function (refer to Section 2.8.3 Control plug X1, Relay outputs)

Warning message

If the actual temperature exceeds the warning temperature the converter displays the message:

warning TCU

Failure message

If the actual temperature exceeds the failure temperature the converter displays the message:

failure TCU

The pump is decelerated. After the pump has cooled down, the failure can be acknowledged and the pump restarted.

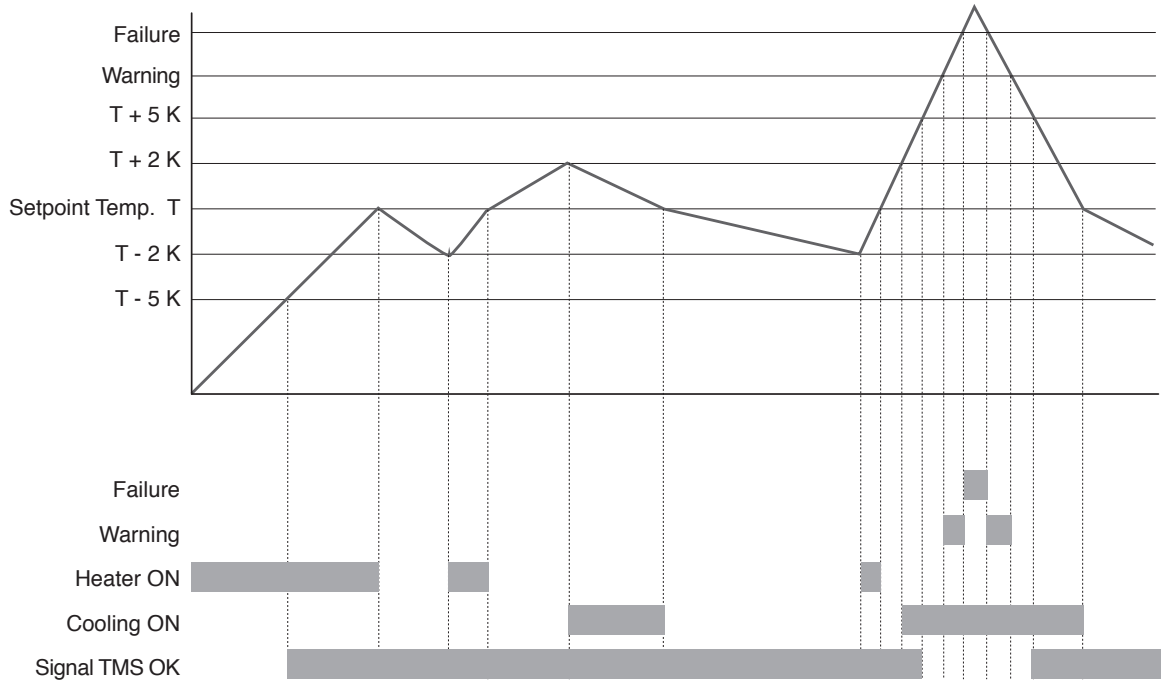

Fig. 46 Function diagram TMS for the MAG.DRIVE L

4.7.2 Temperature Management System for the MAG.DRIVE L2

Function description

The TMS is only in function, when a MAG1600/2000 CT version is connected. The heater will be activated when the mains is switched on. The TMS controls the heating and water cooling to maintain the pump at the specified setpoint temperature.

Settings

The temperature (TMS) setpoint can be programmed via the front panel keys or the serial interface when the pump stands still.

Principally the factory presetting will be used. The setting is saved in the pump's memory chip. Before changing any setpoint value request Leybold!

For the setting refer to 4.6.4 Operating menu, Settings TMS.

Heat up

The setpoint temperature will be reached within 30 to 60 minutes depending on cooling water temperature and flow. If the flow is very high and the temperature low a high temperature setpoint might not be reached. For temperature sensitive applications observe the cooling water specifications (refer to section 1.6 Technical Data).

TMS status code

The TMS status code is displayed on the operation display, see Section 4.2.

Actual temperature

The actual temperature is displayed on the operating display (refer to 4.6.1 Operating menu, Basic menu)

Signal TMS OK

If the actual TMS temperature lies in the range $\pm 5K$ from the setpoint temperature, the TMS OK signal can be output via the option relay. The option relay must be programmed for this function (refer to Section 2.8.3 Control plug X1, Relay outputs)

Warning message ($Temp > T_{set} + 5K$)

If the actual temperature exceeds the warning temperature the converter displays the message:

Warning
TMS

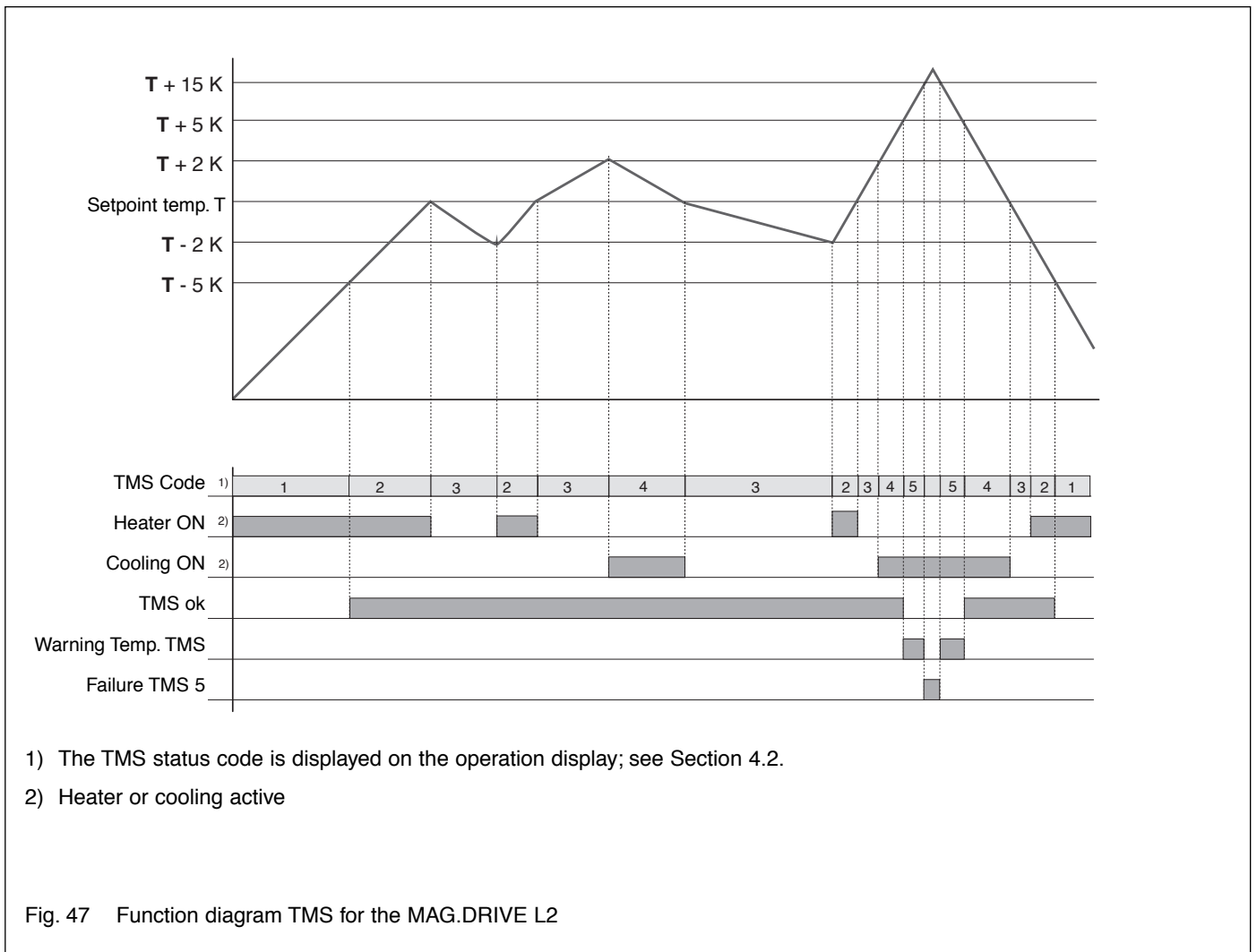

5 Maintenance

The MAG is maintenance-free. Wear only occurs at the touch-down bearings when hard shocks have to be supported or when the pump frequently runs down without venting.

Maintenance is also required after removing the bearing cable during operation of the pump.

Under these conditions the rotor can not be controlled by the magnet bearing and the pump will have a full run down on the touch down bearing.

5.1 Removing the pump from the system

MAG which have been used in semiconductor processes are contaminated by semiconductor process gases. Most of these gases form acids when exposed to moist air which causes serious corrosion damage to the pump.

To prevent corrosion damage during storage and shipping, use the seal kit.

Failure to seal a contaminated MAG voids the warranty.

The seal kit contains the following

- dry cartridge,
- plastic cap for forevacuum connection flange,
- plastic adhesive film and
- aluminum cover and screws for the high-vacuum connection flange.

Proceed as follows to seal the turbomolecular pump immediately after removing it from your process.

Purge the pump for two hours with the backing pump running. This helps to remove a large quantity of the process gases from the pump. We recommend purging the pump via the intake flange and the purge valve with approx. 200 sccm.

Press the STOP button at the MAG.DRIVE and wait until the pump has come to a standstill.

Afterwards turn the mains switch to the „0“ position.

The cables between the MAG and MAG.DRIVE may be disconnected only after the MAG has come to a full still-stand **and** the mains is switched off.

Warning



When the pump has been pumping hazardous gases, ensure that proper safety precautions are taken before opening the intake or exhaust connections.



Use gloves or protective clothing to avoid skin contact with toxic or highly corrosive substances. Work under a fume hood if available.



Disconnect the cables from the pump.

Disconnect the forevacuum line.

Disconnect the cooling water lines. Remaining cooling water may flow out. Protect all parts below.

Remove 10 of the 12 bolts which hold the intake flange. The 2 remaining bolts must be directly opposite.

Support the pump with a lift-truck at the base plate and remove the 2 remaining bolts.

Clean the intake and forevacuum connection flange as necessary for good adhesion of tape.

Place the dry cartridge into the forevacuum port. Don't use loose crystals.

Firmly seal all ports with plastic adhesive film.

Cover the forevacuum connection port with its plastic cap.

Seal the high-vacuum connection flange with the cover and the screws.

Pack the pump so that it may not be damaged during transportation. Particularly protect the flanges, the cooling water connectors and the current feedthrough.

Only for MAG 1600

As the plastic adhesive film is too large for the high-vacuum connection flange slit it a little bit at the screw holes.

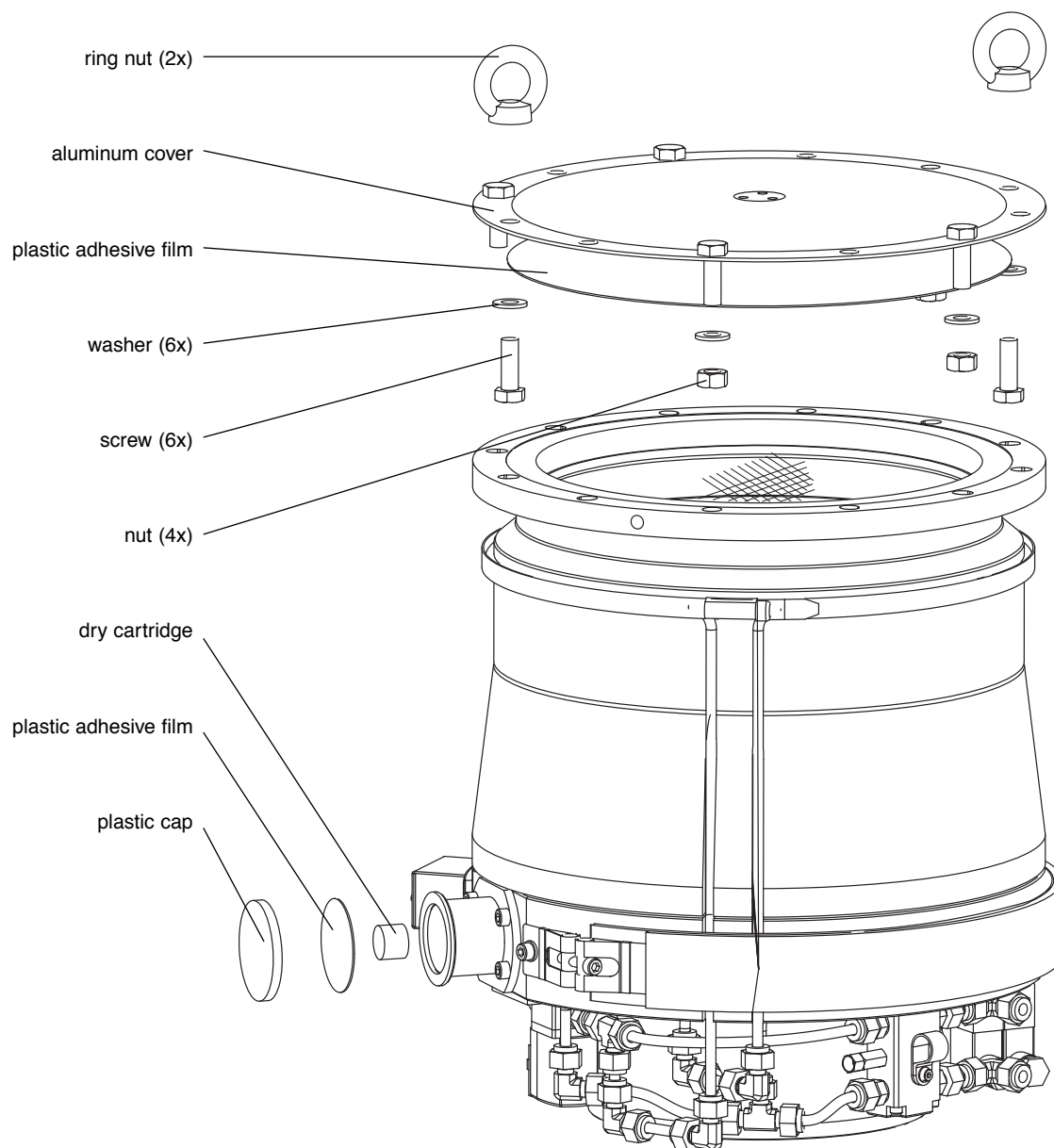

Fig. 48 Sealing the MAG tightly

5.2 Service at Leybold's

If you send a pump to Leybold indicate whether the pump is free of substances damaging to health or whether it is contaminated. If it is contaminated also indicate the nature of hazard. To do so, you must use a pre-printed form which we shall send to you upon request.

A copy of this form is printed at the end of the Operating Instructions: „Declaration of Contamination of Vacuum Equipment and Components“.

Either fasten this form at the pump or simply enclose it to the pump.

Don't pack the form with the pump into the PE bag.

This declaration of contamination is necessary to comply with legal requirements and to protect our staff.

Leybold must return any pump without a declaration of contamination to the sender's address.

6 Troubleshooting

In case of a malfunction, the MAG will be braked and the first line of the display shows

FAILURE

Malfunction messages can be cancelled once the pump has come to a stop and after the malfunction has been rectified; do so with the STOP function (button or serial interface).

Warning



The MAG shall be stopped completely and the mains power cord detached before you open the MAG.DRIVE. Since dangerous voltages may nonetheless be encountered, the housing must be opened only by a qualified electrician.

6.1 Troubleshooting for the MAG.DRIVE L

6.1.1 Warning and failure messages

Warning/Failure Message on Display	Possible Cause	Corrective Action
<p>Temp. Motor Temperature sensor inside the motor reads a higher temperature than the limitation.</p>	<p>BEARING cable or connector damaged.</p> <p>Drive failure.</p>	<p>Check BEARING connector and cable. Measure resistance of KTY (temperature sensor motor) at BEARING connector (pump side) between X23/x - X23/w, default $2k\Omega \pm 1\%$.</p> <p>Service pump.</p>
<p>temp. pump Temperature sensor inside the pump reads a higher temperature than the limitation.</p>	<p>No or too low cooling water.</p> <p>BEARING cable or connector damaged. Pt 100 (temp. sensor bearing) damaged.</p>	<p>Set cooling water according to specifications. Check cooling lines for deposits. See Section 2.6.</p> <p>Check cable, Pt 100 wires and connector. In particular measure resistance between X23/v - X23/u and X23/v - X23/t, typical resistances are in the range of $110\ \Omega$ to $130\ \Omega$ at $20\ ^\circ\text{C}$ to $70\ ^\circ\text{C}$.</p>
<p>temp. cool. water Temperature sensor at cooling water block reads a higher temperature than the limitation.</p>	<p>No or too low cooling water.</p> <p>Temperature sensor cooler (Pt 100) failure. TMS cables damaged.</p>	<p>Set cooling water according to specifications. Check cooling lines for deposits. See Section 2.6.</p> <p>Check TMS cable, Pt 100 wires and connector. In particular measure resistance between X30/V - X30/S, typical resistances are in the range of $110\ \Omega$ to $130\ \Omega$ at $20\ ^\circ\text{C}$ to $70\ ^\circ\text{C}$.</p>
<p>TCU Temperature sensor at base flange reads a higher temperature than the limitation.</p>	<p>No or too low cooling water.</p> <p>Temperature sensor TMS (Pt 100) failure or TMS cable or connectors damaged.</p> <p>Water valve malfunction.</p>	<p>Set cooling water according to specifications. Check cooling lines for deposits. See Section 2.6.</p> <p>Check TMS cable, Pt 100 wires and connector. In particular measure resistance between X30/F - X30/H and X30/F - X30/G, typical resistances are in the range of $110\ \Omega$ to $130\ \Omega$ at $20\ ^\circ\text{C}$ to $70\ ^\circ\text{C}$.</p> <p>If temperature sensor TMS (Pt 100) is ok, unplug it. The water valve should open instantly with a clicking noise and the red LED inside the valve connector lights up.</p>
<p>temp. converter Temperature sensor inside of the converter reads a higher temperature than the limitation ($65\ ^\circ\text{C}$).</p>	<p>Frequent run up and down.</p> <p>No sufficient air circulation.</p>	<p>Let the converter cool down and restart.</p> <p>Check mounting position and clearances inside the rack. See Section 2.8. Check ambient temperature and watch for other heat sources.</p>
<p>unbalanc. PVW13 unbalanc. PVW24 unbalanc. PZ12 Converter senses that rotor displacement has exceeded the limitation.</p>	<p>Mechanical shocks, perhaps due to tool maintenance.</p> <p>BEARING cable or connector damaged.</p> <p>High active magnetic bearing current due to shock venting or transport seal not removed.</p> <p>Internal failure.</p>	<p>Acknowledge failure by pressing stop and try to restart pump.</p> <p>Check unbalance PV13 / PW24 / PZ12 reading via display (basic menu) during acceleration. Check BEARING connector and cable for bended pins.</p> <p>Check the chamber pressure in the operation cycle. Remove transport seal; see Section 2.4.</p> <p>Replace pump or converter or whole system.</p>

6.1.2 Failure messages

Failure Message on Display	Possible Cause	Corrective Action
<p>MB-Code wrong Converter senses that magnetic bearing is not active.</p>	<p>Internal fuse for power supply active magnetic bearing PC boards blown. Overloaded active magnetic bearing. BEARING cable connected while the converter was powered.</p>	<p>Replace converter.</p>
<p>no motor current</p>	<p>DRIVE cable not connected or damaged. Connectors damaged or pins have no contact. Motor coils damaged.</p>	<p>Check cables and connectors, straighten pins if required. Replace pump.</p>
<p>max. accel. Time The maximum acceleration time has been exceeded.</p>	<p>Backing pressure or inlet pressure too high during start-up. Parameter max. Accel. time is not set properly.</p>	<p>Check pressures. Set parameter max. Accel. time to default 1000 s. See Section 4.5.3/4.6.3 Settings pump.</p>
<p>max. power time Rotational speed dropped below normal operation range for more than the max. accel. time.</p>	<p>Backing or inlet pressure too high. Process flows too high. Parameters max. Accel. time or Normal Operation not set properly.</p>	<p>Check pressures. Set parameter max. Accel. time to default 1000 s. Set parameter Normal Operation to default 95 %. See Section 4.5.3/4.6.3 Settings pump.</p>
<p>min. frequency Rotational speed dropped below the minimum frequency threshold.</p>	<p>Backing or inlet pressure too high. Process flows too high.</p>	<p>Check pressures.</p>

6.1.3 Warning messages

Warning Message on Display	Possible Cause	Corrective Action
<p>PK communication Converter does not communicate with the memory chip inside of the pump.</p>	<p>BEARING cable not connected or damaged. Memory chip inside magnetic bearing cartridge is damaged.</p>	<p>Check BEARING cable and connectors. Replace pump.</p>
<p>max. power</p>	<p>Backing or inlet pressure too high. Process flows too high. Parameters max. Accel. time or Normal Operation not set properly.</p>	<p>Check pressures. Set parameter max. Accel. time to default 1000 s. Set parameter Normal Operation to default 95 %. See Section 4.5.3/4.6.3 Settings pump.</p>
<p>max. frequency</p>	<p>Frequency exceeds the setpoint for more than 2 Hz.</p>	<p>Motor current decreases to 0 Amp. The rotor frequency decreases to the normal operation range via gas friction.</p>
<p>Kin. Buffer The converter works in generator mode.</p>	<p>Mains power off.</p>	<p>Switch the mains power on. Locate and eliminate the cause of the mains failure. The pump should handle numerous power failures.</p>

6.1.4 Malfunctions

Malfunction	Possible Cause	Corrective Action
Converter dead, nothing happens after mains switched on.	No power supply. Fuse F1 blown.	Check if the green LED above the mains switch lights up. Check mains cable and connectors. Check power supply. Replace converter.
Display malfunction, confusing failure messages. No reaction when pressing keys.	Internal failure.	Replace converter.
Leaks of the vacuum chamber while the pump is stopped.	Purge gas and venting valve open or malfunctioning.	Open and close purge gas and venting valve via control plug X1. LED on the valve must light up and a clicking noise can be heard. Foreline pressure drops while the valve is closed.
No purge gas flow	No purge gas flow. Valve malfunction. Wrong setting in the programming menu: Settings pump: pump type	Set purge flow according to specification. Open and close purge gas and venting valve via control plug X1. LED on the valve must light up and a clicking noise can be heard. Foreline pressure drops while the valve is closed. Compare pump type (label on the pump) with parameter setting. Refer to Section 4.5.3/4.6.3 Settings pump.
Pump does not accelerate to more than 16 Hz	No vacuum at all. Internal converter or pump failure.	Check pressures. Replace converter or pump or whole system.
Base pressure not reached.	Degassing surfaces of rotor and stator. If the pump was not stored in a dry environment or was too long open to wet ambient air all internal surfaces will be covered with a layer of water.	Let the pump system run for 3 to 5 hours to reach a base pressure below 10^{-5} mbar.
MAG does not heat up.	Wrong setting TMS setpoint. Fuse F3 at rear panel of converter blown or damaged. TMS heater jacket defective. TMS cable or connectors damaged.	Check TMS setpoint. Default 63 °C. Refer to Section 4.5.5. Replace fuse (F 4 A, 5x20 mm). Measure resistance of heater, typical approx. 70 Ω (connector pump side X30/A and X30/B). Measure resistance between pins X31/A1 and X31/A2 at TMS cable when pump is connected.
Display becomes blurred.	Converter temperature high or very low.	It's just the display. It becomes distinct at moderate temperatures.

6.2 Troubleshooting for the MAG.DRIVE L2

6.2.1 Warning messages

Warning Message on Display	Possible Cause	Measures
<p>Motor Temp. Temperature sensor inside the motor reads a higher temperature value than the warning threshold (100 °C). Message will not be activated as long as warning threshold = failure threshold.</p>	<p>Motor temperature exceeds the warning threshold e.g. due to a high gas load.</p> <p>Drive failure or internal converter failure.</p>	<p>Take the actual motor temperature reading from the display; see Section 4.6.1. Reduce gas load. If the warning persists contact Leybold service.</p> <p>Contact Leybold service.</p>
<p>Bearing Temp. Temperature sensor inside the pump reads a higher temperature value than the warning threshold (68 °C).</p>	<p>Cooling water flow too low or cooling water temperature too high.</p> <p>Frequent acceleration and deceleration of the pump.</p>	<p>Apply cooling water according to specifications. Check cooling water tubes for deposits. See also Section 2.6.</p> <p>Allow pump to cool down between the cycles.</p>
<p>Cooling Temp. Temperature sensor at cooling water block reads a higher temperature value than the warning threshold (40 °C).</p>	<p>Cooling water flow too low or cooling water temperature too high.</p>	<p>Apply cooling water according to specifications. Check cooling water tubes for deposits. See also Section 2.6.</p>
<p>Converter Temp. Temperature sensor inside of the converter reads a higher temperature value than the warning threshold (69 °C).</p>	<p>Frequent acceleration and deceleration of the pump.</p> <p>No sufficient air circulation.</p>	<p>Allow converter to cool down between the cycles.</p> <p>Refer to Section 2.8 for the correct mounting of the converter in a rack; max. ambient temperature 45 °C.</p>
<p>Overspeed The frequency exceeds the frequency setpoint by more than 10 Hz.</p>	<p>Changing the frequency setpoint during operation to a lower value.</p>	<p>Motor current decreases to 0 Amp. The rotor frequency decreases to the setpoint via gas friction.</p>
<p>TMS TMS temperature sensor reads a temperature higher than the TMS setpoint +5 °C.</p>	<p>Cooling water flow too low or cooling water temperature too high.</p> <p>Wrong TMS temperature setpoint.</p>	<p>Apply cooling water according to specifications. Check cooling water tubes for deposits. See also Section 2.6.</p> <p>Check the TMS setpoint (default 63 °C). For the correct setting refer to Section 4.6.4.</p>
<p>Unbalanc. PVW13 Unbalanc. PVW24 Unbalanc. PZ12 A rotor displacement exceeding the warning threshold occurred. The code designates the affected axis.</p>	<p>Mechanical shocks, perhaps due to tool maintenance.</p> <p>Shock venting.</p> <p>Converter failure.</p>	<p>If warning message persists contact Leybold service.</p> <p>Check the chamber pressure during operation.</p> <p>Contact Leybold service.</p>
<p>Overload The rotational speed dropped below normal operation frequency.</p>	<p>Backing pressure too high during operation.</p> <p>Parameters „Normal Operation“ are not set correctly.</p>	<p>Reduce backing pressure. Additionally, check process gas flow.</p> <p>Set parameter „Normal Operation“ to default 95%. Refer also to Section 4.6.3.</p>

Warning Message on Display	Possible Cause	Measures
Kinetic Buffer The converter is in the generator mode.	Mains interrupted or converter switched off during operation of the pump.	Reconnect converter to the mains. Switch on the converter.
Op. Without Purge The warning indicates that a C/CT type of pump is operated while the purge gas valve is closed.	Purge gas function disabled.	Set purge gas function to Purge ON. (Key panel or control connector X1).

6.2.2 Failure messages

Failure Message on Display	Possible Cause	Measures
<p>Motor Temp. Temperature sensor inside the motor reads a higher temperature value than the failure threshold (100 °C).</p>	<p>Motor temperature exceeds the failure threshold e.g. due to a high gas load.</p> <p>Motor temperature sensor defective.</p> <p>BEARING cable or connector damaged.</p> <p>Converter failure.</p>	<p>Acknowledge failure message.</p> <p>Take the actual motor temperature reading from the display; see Section 4.6.1. Reduce gas load. If the warning persists contact Leybold service.</p> <p>Step 1: Check pump (temperature sensor) Check pump connector X23. In particular measure resistance between pins X23/x and X23/w. The resistance is typically $2k\Omega \pm 1\%$. In case of abnormal values ($> 3.4 k\Omega$) are measured contact Leybold service.</p> <p>Step 2: Check BEARING cable If step 1 was successful do the following: Check BEARING cable for bent pins Measure the resistance between pins X24/A9 and X24/B9 with the cable connected to the pump. The resistance is typically $2k\Omega \pm 1\%$. Replace the cable if it is damaged or in case the measurement of the resistance shows abnormal values ($> 3.4 k\Omega$) now. Contact Leybold service.</p>
<p>Cooling Temp. Temperature sensor at cooling water block reads a higher temperature value than the failure threshold (50 °C).</p>	<p>Cooling water flow too low or cooling water temperature too high.</p> <p>Pt 100 (cooling water temperature sensor) damaged.</p> <p>TMS cable or connectors damaged.</p> <p>Converter failure.</p>	<p>Apply cooling water according to specifications. Check cooling water tubes for deposits. See also Section 2.6.</p> <p>Step 1: Check cooling water temperature sensor Check pump connector X30. In particular measure resistance between pins X30/S and X30/V. The resistance is typically between 110Ω and 130Ω (20 °C to 70 °C).</p> <p>Step 2: Check TMS cable and connectors If step 1 was successful do the following: Check TMS cable for bent pins Measure the resistance between pins X31/A4 and X31/A5 with the TMS cable connected to the pump. The resistance is typically between 110Ω and 130Ω (20 °C to 70 °C). Replace TMS cable if it is damaged or in case the measurement of the resistance shows abnormal values now. Contact Leybold service.</p>

Failure Message on Display	Possible Cause	Measures
<p>Bearing Temp. Temperature sensor inside the pump reads a higher temperature value than the failure threshold (70 °C).</p>	<p>Cooling water flow too low or cooling water temperature too high.</p> <p>Frequent acceleration and deceleration of the pump.</p> <p>Pt 100 (temperature sensor bearing) damaged.</p> <p>BEARING cable or connectors damaged.</p> <p>Converter failure.</p>	<p>Apply cooling water according to specifications. Check cooling water tubes for deposits. See also Section 2.6.</p> <p>Allow pump to cool down between the cycles.</p> <p>Step 1: Check pump (temperature sensor) Check pump connector X23. In particular measure resistance between pins X23/v and X23/u as well as between pins X23/v and X23/t. The resistance is typically between 110 Ω and 130 Ω (20 °C to 70 °C). In case abnormal values are measured contact Leybold service.</p> <p>Step 2: Check BEARING cable If step 1 was successful do the following: Check BEARING cable for bent pins Measure the resistance between pins X24/B7 and X24/C7 as well as between pins X24/B7 and X24/D7 with the cable connected to the pump. The resistance is typically between 110 Ω and 130 Ω (20 °C to 70 °C). Replace the cable if it is damaged or in case the measurement of the resistance shows abnormal values now.</p> <p>Contact Leybold service.</p>
<p>Converter Temp. Temperature sensor inside of the converter reads a higher temperature value than the failure threshold (74 °C).</p>	<p>Frequent acceleration and deceleration of the pump.</p> <p>No sufficient air circulation.</p> <p>Converter failure.</p>	<p>Allow converter to cool down between the cycles.</p> <p>Refer to Section 2.8 for the correct mounting of the converter in a rack; max. ambient temperature 45 °C.</p> <p>Contact Leybold service.</p>
<p>TMS 1 The converter measures a heating current of less than 300 mA when heater is on.</p>	<p>A TMS 2 ... 5 failure occurred and was subsequently acknowledged.</p> <p>Fuse F3 (rear panel) blown.</p> <p>Heating element or internal pump connection damaged.</p> <p>TMS cable or connectors damaged.</p> <p>Converter failure.</p>	<p>Acknowledge TMS 1 failure message (possibly several times).</p> <p>Step 1: Check fuse Replace fuse F3 (F4A, 5x20 mm) if blown.</p> <p>Step 2: Check pump (heating element) Check if the connector of the heating element is connected. Check pump connector X30. In particular measure resistance between pins X30/A and X30/B. The resistance is typically between 70 Ω and 75 Ω. In case abnormal values are measured contact Leybold service.</p> <p>Step 3: Check TMS cable If step 2 was successful do the following: Check TMS cable for bent pins Measure resistance between pins X31/A1 and X31/A2 with the cable connected to the pump. The resistance is typically between 70 Ω and 75 Ω. Replace the cable if it is damaged or in case the measurement of the resistance shows abnormal values now.</p> <p>Contact Leybold service.</p>

Failure Message on Display	Possible Cause	Measures
<p>TMS 2 The converter measures a heating current of more than 4 A.</p>	<p>Overvoltage. Heating element defective. Converter failure.</p>	<p>Check the line voltage (200-240 V +10% / -15%). Repeat step 2 of failure TMS 1. In case the measured value is less than 60 Ω contact Leybold service. Contact Leybold service.</p>
<p>TMS 3 TMS temperature sensor reads a temperature higher than 99 °C.</p>	<p>TMS sensor damaged. TMS cable damaged. Converter failure.</p>	<p>Step 1: Check TMS sensor Check pump connector X30. In particular measure resistance between pins X30/F and X30/H as well as between pins X30/F and X30/G. The resistance is typically between 110 Ω and 130 Ω (20 °C to 70 °C). Step 2: Additional TMS sensor test If temperature sensor TMS (Pt 100) has the correct resistance, unplug it while the pump is on power. The water valve should open instantly with a clicking noise and a red LED inside the cooling water valve connector lighting up. This LED should be on if the actual TMS temperature is higher than the TMS setpoint + 2 °C. Contact Leybold service if the sensor is defective. Step 3: Check TMS cable Check TMS cable connector X31. In particular measure resistance between pins X31/A8 and X31/C8 as well as between pins X31/A8 and X31/B8. The resistance is typically between 110 Ω and 130 Ω (20 °C to 70 °C). Contact Leybold service if the TMS cable is damaged. Contact Leybold service.</p>
<p>TMS 4 TMS temperature sensor reads a temperature lower than 1 °C.</p>	<p>TMS sensor short-circuited. TMS cable short-circuited. Converter failure.</p>	<p>Repeat steps 1 and 2 of failure TMS 3. Contact Leybold service if the sensor is defective. Repeat step 3 of failure TMS 3. Contact Leybold service if the cable is damaged. Contact Leybold service.</p>
<p>TMS 5 TMS temperature sensor reads a temperature higher than the TMS setpoint + 15 °C.</p>	<p>Cooling water flow too low or cooling water temperature too high. Cooling water valve malfunctioning. Wrong TMS temperature setpoint.</p>	<p>Apply cooling water according to specifications. Check cooling water tubes for deposits. See also Section 2.6. Repeat step 2 of failure TMS 3. Contact Leybold service if cooling water valve is malfunctioning. Check the TMS setpoint (default 63 °C). For the correct settings refer to Section 4.6.4.</p>

Failure Message on Display	Possible Cause	Measures
<p>Overload PZ 12 Overload PV 13 Overload PW 24</p> <p>An abnormal displacement of the rotor occurred at frequencies between 0 and 5 Hz. The code designates the affected axis.</p>	<p>Mechanical shocks, possibly due to tool maintenance when the rotor stands still.</p> <p>Pump is still protected with transport seal on power up.</p> <p>BEARING cable or connector damaged.</p>	<p>Acknowledge failure message and restart the pump. If failure message persists contact Leybold service.</p> <p>Remove transport seal; see Section 2.4.</p> <p>Check BEARING connector and cable for bent pins. Contact Leybold service if the cable is damaged.</p>
<p>MB MB, Purge ON MB, Purge OFF</p> <p>An abnormal displacement of the rotor occurred at frequencies between 130 Hz and 480 Hz.</p> <p>The additional message gives information on the status of the purge gas valve the moment the failure occurred. It can be used to estimate the run down time of the pump.</p>	<p>Mechanical shocks, possibly due to tool maintenance.</p> <p>Shock venting.</p> <p>Converter failure.</p>	<p>Acknowledge failure message and restart the pump. If failure message persists contact Leybold service.</p> <p>Check the chamber pressure during the operation. Refer to Section 3.3 for correct venting of the pump.</p> <p>Contact Leybold service.</p>
<p>PK Communication</p> <p>Converter does not communicate with the memory chip inside of the pump.</p>	<p>BEARING cable not connected or damaged.</p> <p>Memory chip inside of magnetic bearing cartridge malfunctioning.</p>	<p>Check BEARING connector and cable for damages or bent pins. Contact Leybold service if the cable is damaged.</p> <p>Contact Leybold service.</p>
<p>MB-Code Wrong</p> <p>Magnetic bearing controller does not work.</p>	<p>Converter failure.</p>	<p>Contact Leybold service.</p>
<p>Starting Time</p> <p>The frequency has not reached 40 Hz 2 minutes after the start command was applied.</p>	<p>Backing pressure too high during start-up.</p> <p>Rotor blocked.</p>	<p>Reduce backing pressure.</p> <p>Check if the rotor rotates freely. Contact Leybold service if the rotor is damaged or blocked.</p>
<p>Accel. Time</p> <p>The pump does not reach the normal operation frequency after the set maximum acceleration time.</p>	<p>Backing pressure too high during start-up.</p> <p>Parameter „Accel. Time“ is not set correctly.</p>	<p>Reduce backing pressure.</p> <p>Set parameter „Accel. Time“ to default 1000 s; see Section 4.6.3.</p>
<p>Overload Time</p> <p>The rotational speed has dropped below normal operation frequency and stays there for longer than the maximum „Accel. Time“.</p>	<p>Backing pressure too high during operation.</p> <p>Parameters „Accel. Time“ or „Normal Operation“ are not set correctly.</p>	<p>Reduce backing pressure. Additionally check process gas flow.</p> <p>Set parameter „Normal Operation“ to default 95 % and parameter „Accel. Time“ to default 1000 s; see Section 4.6.3.</p>
<p>Shutdown Freq.</p> <p>Rotational speed dropped below the shutdown frequency threshold (140 Hz).</p>	<p>Backing pressure too high during operation.</p>	<p>Reduce backing pressure. Additionally check process gas flow.</p>

Failure Message on Display	Possible Cause	Measures
<p>Cooling Temp. SC The cooling water temperature sensor reads a temperature lower than 1 °C.</p>	<p>Temperature sensor Pt 100 short-circuited. TMS cable short-circuited. Converter failure.</p>	<p>Repeat step 1 of „failure Cooling Temp.“. Contact Leybold service if the resistance of the sensor is less than 100 Ω. Repeat step 2 of „failure Cooling Temp.“. Contact Leybold service if the resistance of the sensor is less than 100 Ω. Contact Leybold service.</p>
<p>Bearing Temp. SC The magnetic bearing temperature sensor reads a temperature lower than 1 °C.</p>	<p>Temperature sensor Pt 100 short-circuited. BEARING cable short-circuited. Converter failure.</p>	<p>Repeat step 1 of „failure Bearing Temp.“. Contact Leybold service if the resistance of the sensor is less than 100 Ω. Repeat step 2 of „failure Bearing Temp.“. Contact Leybold service if the resistance of the sensor is less than 100 Ω. Contact Leybold service.</p>
<p>Motor Temp. SC The motor temperature sensor reads a temperature lower than 1 °C.</p>	<p>Temperature sensor KTY short-circuited. BEARING cable short-circuited. Converter failure.</p>	<p>Repeat step 1 of „failure Motor Temp.“. Contact Leybold service if the resistance of the sensor is less than 1.62 kΩ. Repeat step 2 of „failure Motor Temp.“. Contact Leybold service if the resistance of the sensor is less than 1.62 kΩ. Contact Leybold service.</p>
<p>Connection pump</p>	<p>BEARING cable not connected. Converter failure.</p>	<p>Check if the BEARING cable is connected to the pump and the converter. Acknowledge failure message. Contact Leybold service.</p>
<p>Frequency Abnormal motor current or frequency</p>	<p>On START command: DRIVE cable not connected or connectors damaged. The rotor frequency exceeds 515 Hz. A STOP command followed by a START command given while the warning „Over-speed“ is displayed.</p>	<p>Check cables and connectors, straighten pins if required. Acknowledge failure message; see Section 4.4. If failure persists contact Leybold service. Acknowledge failure message and restart the pump.</p>

6.2.3 Malfunctions

Malfunction	Possible Cause	Measures
Converter dead, LED „mains“ does not light up after switching on.	No power supply. Fuse F1 blown or converter failure.	Check the line voltage. Contact Leybold service.
Display malfunction, confusing messages. No reaction when pressing keys.	Converter failure.	Switch the converter off and on again. If the converter still malfunctions contact Leybold service.
Vacuum chamber pressure rises above normal backing pressure while the pump is stopped.	Purge gas and venting valve open or malfunctioning.	Open and close purge gas and/or venting valve via control plug X1. LED on the valve must light up and a clicking noise can be heard. Foreline pressure drops while the valve is closed.
No purge gas flow	Valve malfunctioning.	Set purge flow according to specification. Open and close purge gas and venting valve via control plug X1. LED on the valve must light up and a clicking noise can be heard. Foreline pressure drops while the valve is closed.
Base pressure not reached.	Degassing surfaces of rotor and stator. If the pump was stored in a humid environment or was exposed to humid ambient air all surfaces will be covered with condensation.	Leave the pump system run for 3 to 5 hours to reach a pressure below 10^{-5} mbar.
MAG 1600/2000 CT does not heat up.	TMS failure.	See TMS failures.
Display blurred.	Ambient temperature too high or too low.	Operate the converter according to the specifications.

EC declaration of manufacture

in accordance with Art. 4 paragraph 2 of EC directive 89/392/EEC changed by 91/368EEC and 93/44/EEC, Appendix IIB

Document No.: **MSR0196 / MAG.DRIVE L**
Manufacturer: **REFU elektronik GmbH**
Product Identification: **MAG.DRIVE L2**
Catalog No.: **857 24**

The product indicated solely for fitting in another machine. Commissioning is prohibited until the conformity of the end product with EC directive 89/392/EEC has been established.

Standards applied: **EN 60204-1 (DIN VDE 0113 part 1)**
EN 61010-1 (DIN VDE 0411 part 1)

1.10. 1997

REFU elektronik GmbH

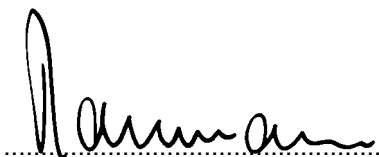

H. Baumann
President

The safety notes given in the product documentation must be observed.

EC declaration of conformity

Document No.: **MSR0196 / MAG.DRIVE L**
Manufacturer: **REFU elektronik GmbH**
Product Identification: **MAG.DRIVE L2**
Catalog No.: **857 24**

Herewith, we declare that this product, as a result of its design and type of construction, and the version marketed by us, correspond to the basic health and safety regulations specified in the EEC Directives.

This declaration is no longer valid if the product is modified without us being in full agreement.

The product conforms to the EEC Low-Voltage Directive (73/23/EEC).

Standards applied: **EN 61010-1 (DIN VDE 411 Teil 1) Edition 1994-03**

Display the CE-mark: **1997**

1.10. 1997

REFU elektronik GmbH

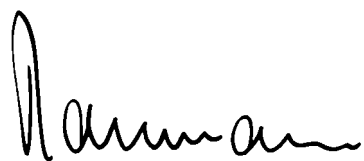

H. Baumann
President

The safety notes given in the product documentation must be observed.

Factory certificate

Document No.: **MSR0196 / MAG.DRIVE L**
Manufacturer: **REFU elektronik GmbH**
Product Identification: **MAG.DRIVE L2**
Catalog No.: **857 24**

The named product, when put to its intended use, satisfies the requirements of Directive 89/336/EEC concerning electromagnetic compatibility.

The applicable measurements were made taking into account the following standards:

EN 500 81-1
EN 500 82-2
EN 55011 (DIN VDE0875 Teil 1)
EN 61000-3-2
EN 61000-3-3

Note

Attention must be paid to the information provided on proper installation with respect to electromagnetic compatibility and to other pertinent notes in the documentation supplied with the product, as well as to the relevant information concerning electrical connection.

1.10. 1997

REFU elektronik GmbH

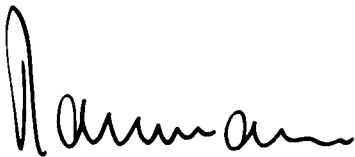

.....
H. Baumann
President

The safety notes given in the product documentation must be observed.

Form TMP-1 ... Turbopump Field Failure Report

Field Service IR No.: _____ RMA No. (if returning to factory): _____

Service Center: _____

Customer: _____

Turbopump Model: _____ Turbopump Pump Part Number: _____

Turbopump Serial Number: _____

Complaint: _____

Process: _____

OEM Equipment Name and Model: _____

Process Gas: _____

Was the turbopump replaced? Yes; No.

If yes, replacement pump P/N: _____ replacement pump S/N: _____

Date Installed: _____ Date Removed: _____

Date Received: _____

Date Examined: _____ Examined by: _____

Received Condition: _____

Findings: _____

Cause of Failure: _____

Recommendations: _____

Remarks/Questions: _____

LEYBOLD VACUUM





Declaration of Contamination of Vacuum Equipment and Components

The repair and/or service of vacuum equipment and components will only be carried out if a correctly completed declaration has been submitted. Non-completion will result in delay. The manufacturer could refuse to accept any equipment without a declaration.

This declaration can only be completed and signed by authorized and qualified staff.

1. Description of Vacuum Equipment and Components

- Equipment type/model: _____
- Code No.: _____
- Serial No.: _____
- Invoice No.: _____
- Delivery date: _____

2. Reason for Return

3. Condition of the Vacuum Equipment and Components

- Has the equipment been used?
yes no
- What type of pump oil/liquid was used? _____
- Is the equipment free from potentially harmful substances?
yes (go to Section 5)
no (go to Section 4)

4. Process related Contamination of Vacuum Equipment and Components:

- toxic yes no
- corrosive yes no
- explosive*) yes no
- biological hazard*) yes no
- radioactive*) yes no
- other harmful substances yes no

*) Vacuum equipment and components which have been contaminated by biological explosive or radioactive substances, will not accepted without written evidence of decontamination!

Please list all substances, gases and by-products which may have come into contact with the equipment:

Trade name Product name Manufacturer	Chemical name (or Symbol)	Dangerous material class	Measures if spillage	First aid in case of human contact
1.				
2.				
3.				
4.				
5.				

5. Legally Binding Declaration

I hereby declare that the information supplied on this form is complete and accurate. The despatch of the contaminated vacuum equipment and components will be in accordance with the appropriate regulations covering Packaging, Transportation and Labelling of Dangerous Substances.

Name of organisation or company: _____

Address: _____ Post code: _____

Tel.: _____

Fax: _____ Telex: _____

Name: _____

Job title: _____

Date: _____ Company stamp: _____

Legally binding signature: _____

Copies: Page 1 (white) to manufacturer or representative - Page 2 (yellow) attach to consignment packaging security - Page 3 (blue) copy for file of sender



LEYBOLD VAKUUM GmbH

Bonner Strasse 498 (Bayenthal)
D-50968 Cologne

Tel.: + 49 (221) 347-0

Fax: + 49 (221) 347-1250

<http://www.leyboldvac.de>

e-mail: documentation@leyboldvac.de