



HARDWARE INSTALLATION GUIDE

September 2018 | 3725-42465-002B

Polycom® SoundStructure® C16, SoundStructure® C12, SoundStructure® C8, and SoundStructure® SR12



Copyright© 2016, Polycom, Inc. All rights reserved. No part of this document may be reproduced, translated into another language or format, or transmitted in any form or by any means, electronic or mechanical, for any purpose, without the express written permission of Polycom, Inc.

6001 America Center Drive
San Jose, CA 95002
USA

Trademarks Polycom®, the Polycom logo and the names and marks associated with Polycom products are trademarks and/or service marks of Polycom, Inc., and are registered and/or common law marks in the United States and various other countries.



All other trademarks are property of their respective owners. No portion hereof may be reproduced or transmitted in any form or by any means, for any purpose other than the recipient's personal use, without the express written permission of Polycom.

Disclaimer While Polycom uses reasonable efforts to include accurate and up-to-date information in this document, Polycom makes no warranties or representations as to its accuracy. Polycom assumes no liability or responsibility for any typographical or other errors or omissions in the content of this document.

Limitation of Liability Polycom and/or its respective suppliers make no representations about the suitability of the information contained in this document for any purpose. Information is provided "as is" without warranty of any kind and is subject to change without notice. The entire risk arising out of its use remains with the recipient. In no event shall Polycom and/or its respective suppliers be liable for any direct, consequential, incidental, special, punitive or other damages whatsoever (including without limitation, damages for loss of business profits, business interruption, or loss of business information), even if Polycom has been advised of the possibility of such damages.

End User License Agreement By using this product, you are agreeing to the terms of the end user license agreement (EULA) at: <http://documents.polycom.com/indexes/licenses>. If you do not agree to the terms of the EULA, do not use the product, and you may return it in the original packaging to the seller from whom you purchased the product.

Patent Information The accompanying product may be protected by one or more U.S. and foreign patents and/or pending patent applications held by Polycom, Inc.

Open Source Software Used in this Product This product may contain open source software. You may receive the open source software from Polycom up to three (3) years after the distribution date of the applicable product or software at a charge not greater than the cost to Polycom of shipping or distributing the software to you. To receive software information, as well as the open source software code used in this product, contact Polycom by email at OpenSourceVideo@polycom.com.

Customer Feedback We are striving to improve our documentation quality and we appreciate your feedback. Email your opinions and comments to DocumentationFeedback@polycom.com.

Polycom Support Visit the [Polycom Support Center](#) for End User License Agreements, software downloads, product documents, product licenses, troubleshooting tips, service requests, and more.

Contents

- Preparing For Installation 6**
 - Overview 6
 - Product Features 6
 - Installation Overview 7
 - Package Contents 7
 - Tools Needed for Installation 8
 - Safety Recommendations 8
 - General Site Requirements 9
 - Power Supply Considerations 9

- Installing the SoundStructure C16, C12, C8, and SR12 10**
 - Panel Diagrams 10
 - Front-Panel 10
 - Front-Panel LED Interpretation 11
 - Rear Panel 11
 - Installing the Hardware 12
 - Plug-in Card Installation 12
 - Rack-Mounting the Polycom SoundStructure Device 14
 - Connecting to the LAN Interface 15
 - Connecting to the Conference Link2 Interface 15
 - Connecting Microphones to SoundStructure 17
 - Using Multiple SoundStructure Devices with OBAM Link Interface 18
 - Device IDs 19
 - Connecting IR Port to Optional Receiver and RS-232 to Control System 21
 - IR Port 21
 - RS-232 22
 - Making Audio Connections 23
 - Connecting Logic Ports 24
 - Logic Inputs 25
 - Analog Gain Input 25
 - Logic Outputs 26
 - Powering the System 27
 - Configuring the SoundStructure Devices 27

Specifications	28
Technical Specifications	28
Dimensions	28
Weight	28
Connectors	28
Power	28
Thermal	28
Inputs	29
Outputs	29
System	29
Telco	30
Pin Out Summary	30
Conference Link2	30
OBAM Link	31
Connector Pinout	32
IR Receiver	32
RS-232	33
Logic Interface	34
Audio Connections	35
Logic Examples	37
Logic Input	37
Contact Closure	37
Logic Output	37
SoundStructure Powered Relay	37
Externally Powered Relay	38
Driving an LED	39
Logic Input and Output	39
Push To Talk Microphones	39
Analog Gain Control	40
Accessories	41
Regulatory Notices And Warranty Information	44
Regulatory Notices	44
USA And Canada	44
Pt 15 Rules	44
Class A Digital Device Or Peripheral	44
Modifications	44
Exhibit J - Customer Information	44

Data Equipment	45
Automatic Dialing	45
Canada	45
Canadian EMC Class A	45
EEA (European Economic Area) Including Switzerland	46
CE Mark R & TTE Directive	46
Australia	46
Mains powered POT's Voice Telephony without Emergency 000 dialing	46
Japan (VCCI)	46
Korea	47
Class A	47
New Zealand	47
General Warning:	47
Important Notice:	47
Russia	47
EMC Class A Device:	48
Safety Considerations for Storage and Transportation	48
Recycling	48
Documentation	48
Troubleshooting	48
Product Manufacturing Information	49
South Africa	49
Taiwan	50
Rest Of World	50
EMC. CLASS A ITE	50
Installation Instructions	50
Plug acts as Disconnect Device	50
Warranty Information	50
LIMITED WARRANTY	50

Preparing For Installation

This guide provides information for the Polycom® SoundStructure® C16, SoundStructure® C12, and SoundStructure® C8 audio conferencing devices, and the SoundStructure® SR12, a sound reinforcement product that is compatible with the Polycom SoundStructure C16, C12, and C8.

This chapter contains the steps to follow before installing this new hardware and includes information on:

- [Overview](#)
- [Installation Overview](#)
- [Package Contents](#)
- [Tools Needed for Installation](#)
- [Safety Recommendations](#)
- [General Site Requirements](#)

To install the Polycom SoundStructure hardware, refer to the section [Installing the Hardware](#).

Overview

The SoundStructure C16, C12, and C8 audio conferencing devices are audio processing devices that have 16 inputs and 16 outputs (C16), 12 inputs and 12 outputs (C12), and 8 inputs and 8 outputs (C8).

The C16, C12, and C8 versions of this product line features acoustic echo cancellation (AEC), noise cancellation, automatic microphone mixing, matrix mixing, equalization, feedback elimination, dynamics processing, delay, and submix processing.

The SR12 does not include acoustic echo cancellation processing but does includes noise cancellation, automatic microphone mixing, matrix mixing, equalization, feedback elimination, dynamics processing, delay, and submix processing.

All the SoundStructure products provide 24-bit A-D/D-A subsystems, 48 kHz sampling, and a dynamic range exceeding 100 dB. A Voice over Internet Protocol (VoIP) interface and two different Public Switched Telephone Network (PSTN) interfaces, a single-line and dual-line, are available.

Product Features

The Polycom SoundStructure C16, C12, C8 and SR12 offer the following features:

- 16 (C16), 12 (C12 and SR12), or 8 (C8) balanced Microphone/line-level inputs
- 48 V phantom power available on all inputs
- 16 (C16), 12 (C12 and SR12), or 8 (C8) balanced line-level outputs
- Rear-panel Ethernet and RS-232 interfaces
- Logic input and output ports (requires firmware v1.3 or higher)

- Optional VoIP and telephone interface cards
- High-speed OBAM link to connect up to eight SoundStructure devices
- High-speed link to connect directly to Polycom® HDX® or Polycom® RealPresence® Group Series video codecs

Installation Overview





To prepare for the installation of the Polycom SoundStructure hardware:

- Review the safety information in [Safety Recommendations](#), and in [Regulatory Notices And Warranty Information](#).
- Unpack the hardware carefully. The contents included in the shipping container are listed in the next section, [Package Contents](#), and [Tools Needed for Installation](#). If any components are missing, contact your Polycom reseller.

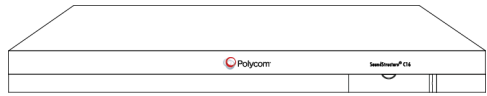
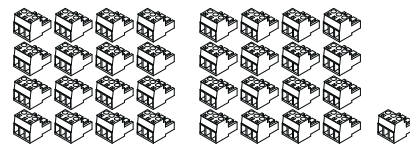
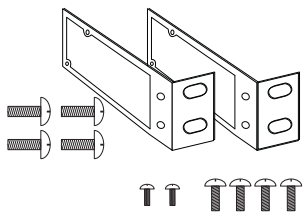
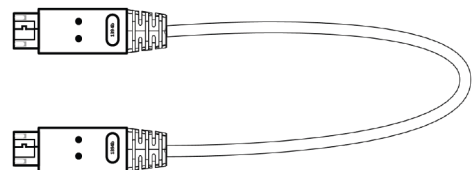
Package Contents

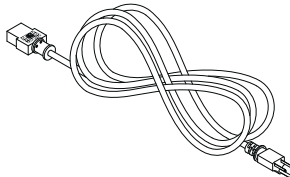
The SoundStructure products include the components shown below.

SoundStructure Components	Graphic
SoundStructure Device	
3.5mm Terminal Blocks	
Rack Ears and Rack-Mounting Screws	
18" OBAM Cable	

SoundStructure Components	Graphic
Power Cable	
Conference Link2 insert plugs	
Rubber Feet	
18" Conference Link2 Cable	
Software CD	



The SoundStructure C16, C12, SR12, and C8 devices have 33, 25, 25, and 17 terminal block connectors respectively including one for the optional IR receiver accessory. The Conference Link2 cable is not included with the SR12.

Check Polycom.com for the latest version of firmware and SoundStructure Studio.

For a complete list of available SoundStructure accessories, see [Accessories](#).

Tools Needed for Installation

The following tools will be required to install your Polycom SoundStructure unit:

- A Phillips head screwdriver for installing rack ears and rack-mounting the device.
- A small blade screwdriver for terminating audio cables to the terminal blocks.

Safety Recommendations

Read and understand the following instructions before using the system:

- Always disconnect the system from power before inserting plug-in cards into the SoundStructure device.
- Only connect the system to surge protected power outlets.
- Only use electrical extension cords with a current rating at least equal to that of the system.
- Always disconnect the system from power before cleaning and servicing and when not in use.
- Do not spray liquids directly onto the system when cleaning. Always apply the liquid first to a static free cloth.
- Do not immerse the system in any liquid or place any liquids on it.
- Do not disassemble this system. To reduce the risk of shock and to maintain the warranty on the system, a qualified technician must perform service or repair work.
- Keep ventilation openings free of any obstructions.
- If the system or any accessories are installed in an enclosed space such as a cabinet or equipment rack, ensure that the air temperature in the enclosure does not exceed 40° C (104° F). Forced cooling may be required to keep the equipment within its operating temperature range.

General Site Requirements

Please ensure the SoundStructure side ventilation holes have at least 1 inch of clearance from the sides of the rack to allow airflow through the device. Failure to maintain clearance for airflow may increase the operating temperature of the unit beyond its maximum operating temperature of 40° C (104° F).

With the proper side clearance and airflow, each SoundStructure device requires one rack space and does not require additional empty rack spaces above or below the device. When mounting with other equipment give consideration to having access to the audio connectors on the rear-panel.

When using SoundStructure with RealPresence Group 700 video codecs, install the SoundStructure devices with at least one rack unit of space between the SoundStructure and the video codec.

If you are placing the device on a tabletop or other flat surface (rather than rack-mounting it), it is recommended to mount the adhesive rubber feet on the bottom of the device as shown in [Rack-Mounting the Polycom SoundStructure Device](#) to prevent damaging the finish of the furniture surface.

Power Supply Considerations

The Polycom SoundStructure C16, C12, C8, and SR12 have the following power requirements on the line power supplied to the devices:

- Input voltage of 100-240 VAC; 50-60 Hz
- Line power requirements (including 0.6 PF):
 - 130 VA (C16),
 - 115 VA (C12),
 - 105 VA (SR12),
 - 95 VA (C8)

Installing the SoundStructure C16, C12, C8, and SR12

This chapter provides information on the Polycom SoundStructure product, rack-mount, and installation procedures.

- [Panel Diagrams](#)
- [Installing the Hardware](#)

Panel Diagrams

This section describes the front and rear-panels of the Polycom SoundStructure C16.



The graphics shown in this guide show the Polycom SoundStructure C16 audio conferencing device. The SoundStructure C12, C8, and SR12 are all very similar in appearance to the C16.

Front-Panel

The front-panel of the Polycom SoundStructure C16 is shown below with the front panel door open, revealing the serial number label and the System Status LED.

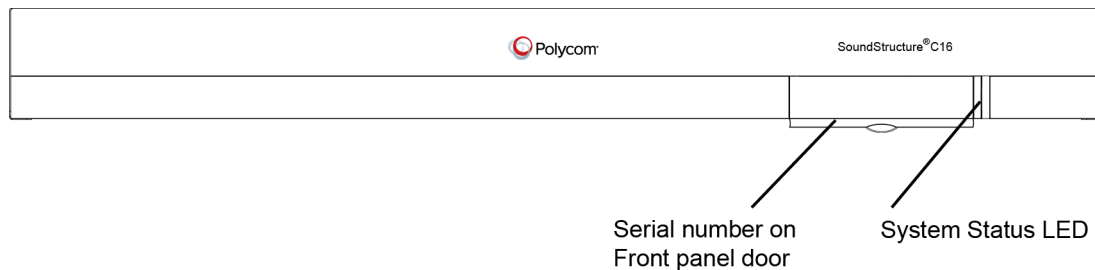

Front-Panel LED Interpretation

The front-panel LEDs are interpreted as follows:

Front-Panel LED Interpretations

LED	Color	State	Description
Status	Green	Flashing	The system is starting up.
		Solid	The system is operating normally.
	Yellow	Solid	The system has logged a warning and the system logs should be reviewed. In multi-device systems, this indicates that the SoundStructure project file loaded into the system does not match the hardware configuration and should be corrected.
	Red	Solid	A system component has failed and requires immediate attention.

Rear Panel

The rear-panel of the Polycom SoundStructure C16 is shown in the following figure.

SoundStructure Rear Panel

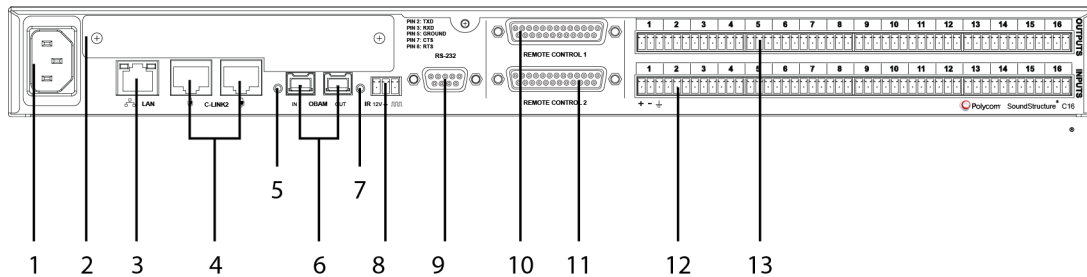

Polycom SoundStructure Figure Description

1 AC power connection	8 IR receiver interface
2 Expansion slot for SoundStructure plug-in cards	9 RS-232 interace
3 Ethernet interface	10 Logic input and output connector
4 Conference Link2 (CLink2) interface	11 Logic input and output connector 2
5 OBAM input status LED	12 Balanced audio input connectors
6 OBAM input and output ports	13 Balanced audio output connectors
7 OBAM output status LED	

Installing the Hardware

To install a SoundStructure device, follow these steps:

- Install optional plug-in card. (See [Plug-in Card Installation](#).)
- Mount the SoundStructure device onto an equipment rack or other location. (See [Rack-Mounting the Polycom SoundStructure Device](#).)
- Connect to LAN for control management. (See [Connecting to the LAN Interface](#).)
- Use Conference Link2 to connect to Polycom HDX system. (See [Connecting to the LAN Interface](#).)
- Use OBAM to connect multiple SoundStructure devices. (See [Using Multiple SoundStructure Devices with OBAM Link Interface](#).)
- Connect IR port to optional receiver and/or RS-232 to control system. (See [Connecting IR Port to Optional Receiver and RS-232 to Control System](#).)
- Connect other devices/equipment using analog input/output. (See [Making Audio Connections](#).)
- Connect optional logic devices. (See [Connecting Logic Ports](#).)
- Connect AC power. (See [Powering the System](#).)
- Configure devices using SoundStructure Studio software. (See [Configuring the SoundStructure Devices](#).)

Plug-in Card Installation

Each SoundStructure device can have one plug-in card installed for a total of eight plug-in cards in a collection of eight SoundStructure devices. When installing more than one plug-in card in an installation, it is recommended to use the plug-in slot from the top device first and continue sequentially down through the collection of devices as additional plug-cards are added.



Do not insert a plug-in card while the SoundStructure is powered on. Failure to remove power prior to installing the plug-in card may damage the plug-in card and/or the SoundStructure device.

To install a plug-in card:

- 1 If plugged in, unplug the AC power cord from the SoundStructure device.

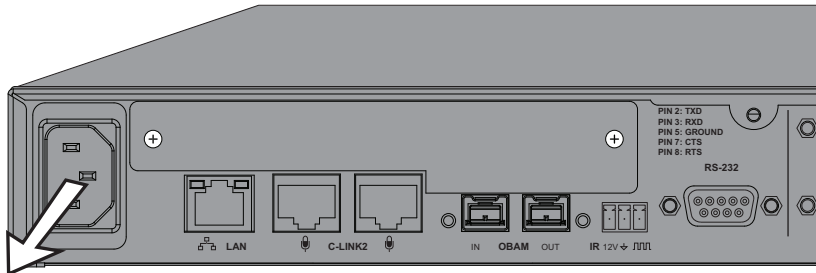

- 2 Remove the blank plate and screws from the expansion slot (see below).

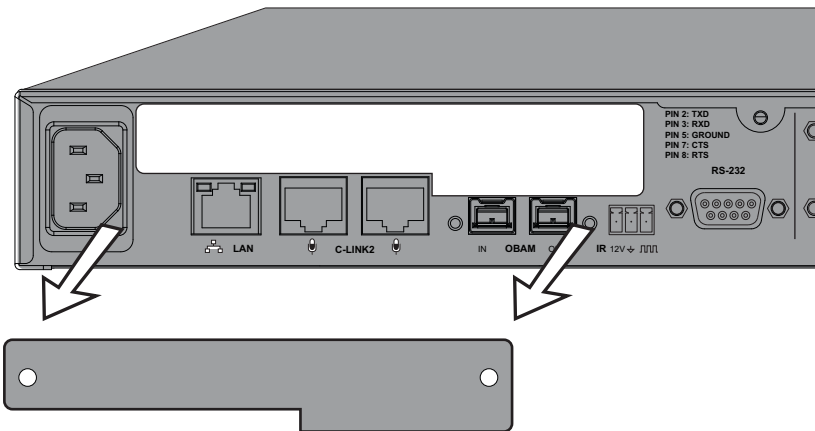

- 3 Insert the plug-in card into the slotted rails and push until it is tight into the slot.

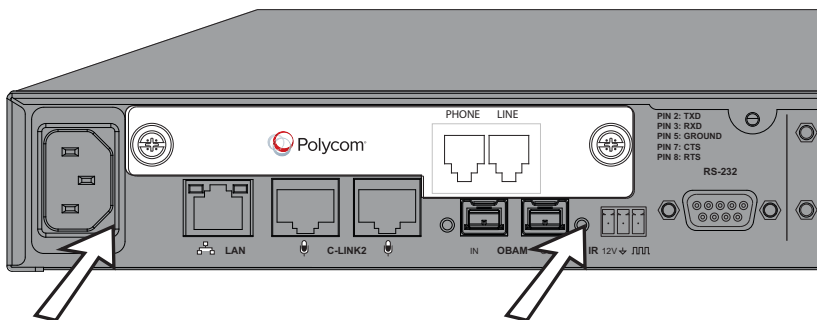

- 4 Tighten the thumbscrews on the rear-panel of the plug-in card.
- 5 If no further installation steps are required, plug in the AC power cable; otherwise, continue with the remainder of the installation steps prior to applying power.

Rack-Mounting the Polycom SoundStructure Device

The Polycom SoundStructure can be mounted in an equipment rack, or placed on a tabletop or other flat surface, or mounted under the table with the optional undertable mounting kit.



Each SoundStructure device requires one rack space and does not require additional empty rack spaces above or below the device when mounting additional SoundStructure devices. When connecting the SoundStructure device to a RealPresence Group 700, Polycom recommends including one rack unit of space between the units.

When multiple devices are racked together, before final tightening of the rack mount screws on each device after the first one, ensure there is enough clearance so that the front-panel door will open freely.

To rack-mount the SoundStructure unit:

- 1 Remove the four front side screws and two mid-side screws on the enclosure.

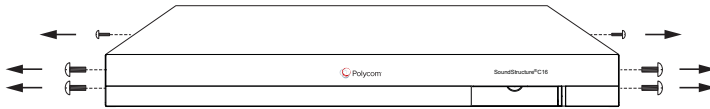

- 2 Align the rack ears, and install the rack ears using the screws that were removed from the enclosure.

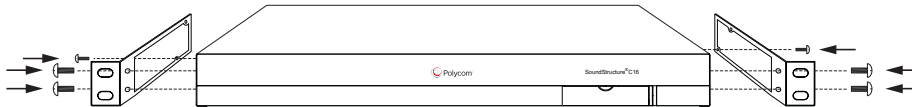

- 3 Mount the equipment in the rack and secure with the four supplied rack mount screws (screw size is 10-32x1/2").

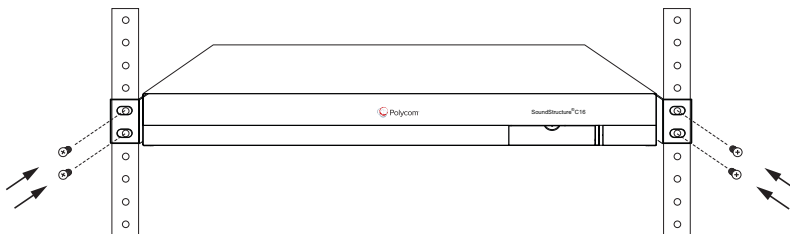

To place on a tabletop or other flat surface:

- » If the equipment will not be mounted in an equipment rack, install the four adhesive rubber feet on the bottom of the device (as shown below) before placing the equipment on furniture.



Connecting to the LAN Interface

The SoundStructure device's Ethernet interface (as shown following figure) is a 10/100 Mbps interface that supports Auto-MDIX (medium dependent interface crossover).

Auto-MDIX enables the use of a standard CAT5e cable to connect directly from the SoundStructure device to either an Ethernet network or to a computer. The SoundStructure device will detect the connection and work appropriately.

SoundStructure Ethernet Interface

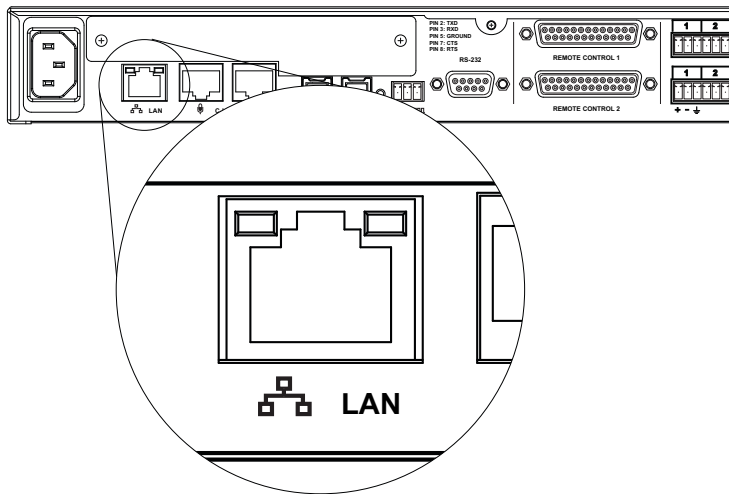

By default the SoundStructure device has Dynamic Host Configuration Protocol (DHCP) enabled and will accept an IP address from a DHCP server. If a DHCP server can not be located, the SoundStructure device will default to a link-local IP address of 169.254.1.1 to make it possible to connect the device directly to the PC without the requirement of setting a manual static IP address on both the PC and the SoundStructure device.

The SoundStructure device IP address can also be set to a static IP address using the SoundStructure Studio software.

Connecting to the Conference Link2 Interface

The Conference Link2 interface, which is labeled as C-Link2 in the following figure, is used to connect the SoundStructure devices to other Polycom equipment such as a Polycom HDX or RealPresence Group Series system or a Polycom Digital Microphone Array.



Do not connect an Ethernet cable to the Conference Link2 Interface. Connecting an Ethernet cable into the Conference Link2 interface of a SoundStructure device could damage the SoundStructure device. To minimize improper cabling, plastic plugs have been installed by default into the Conference Link2 ports.

Conference Link2 Ports

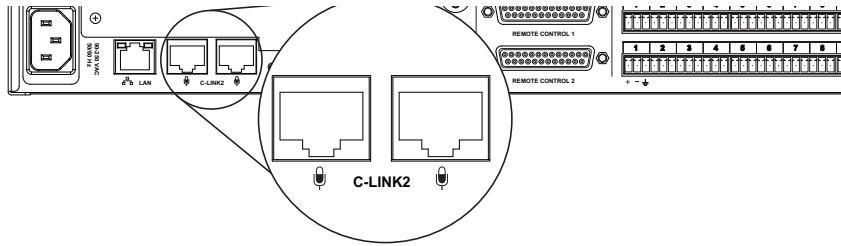

Do not connect the Conference Link2 connectors on one SoundStructure device to a Conference Link2 connector on another SoundStructure device. Doing so could damage the connecting device and/or the SoundStructure device.

Using the supplied 18" Conference Link2 cable, connect the **left** Conference Link2 port (when viewed from the rear panel) on the SoundStructure device to a Polycom microphone Input port on the RealPresence Group Series system, as shown in the following figure. If there are multiple SoundStructure devices linked together with OBAM Link, only one SoundStructure device should be connected to a RealPresence Group Series system.

Connecting the Conference Link2 port to the Polycom HDX system

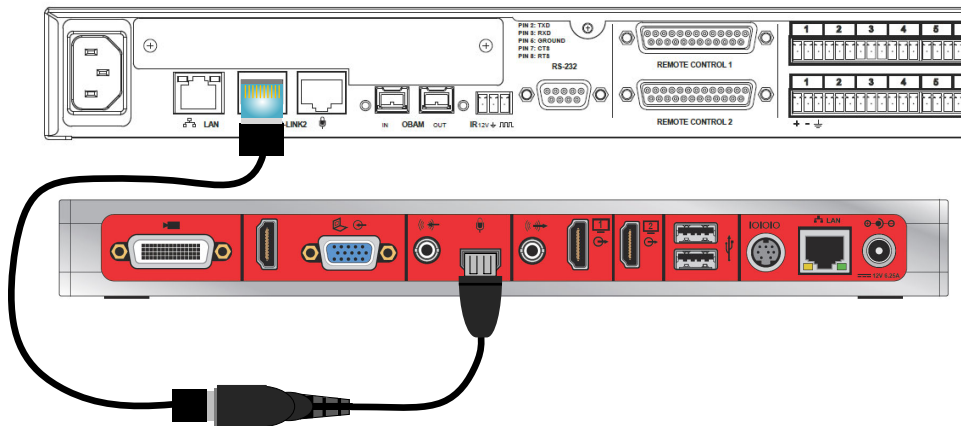

A CAT5e cable that is terminated with standard T568A or T568B pin/pair assignments will not work with Conference Link2. The Conference Link2 pinout is different from T568A or T568B pin/pair termination.

Do not use a standard Ethernet cable to connect SoundStructure to a Polycom HDX or RealPresence Group Series system.

If a longer Conference Link2 cable is required, one may be constructed using the custom pinout (see [Conference Link2](#)) and standard 8P8C (eight positions, eight conductors, e.g., RJ45) connectors, shielded Cat5e cable or better, and standard 8P8C crimping tools. Note that the maximum length between the RealPresence Groups Series system and the SoundStructure device is 100ft (30m).



Do not use Conference Link2 to connect multiple SoundStructure devices together. The OBAM link must be used for connecting multiple SoundStructure devices.

Connecting Microphones to SoundStructure

To connect optional HDX or RealPresence Group Series microphones to a SoundStructure device, connect the Polycom Microphone Cable Adapter to the right CLink2 port (when viewed from the rear) of the SoundStructure device and connect the Polycom HDX or RealPresence Group Series microphone cable to the cable adapter, as shown in the following figure. Chapter 6 of SoundStructure Design Guide has additional information on how to use the HDX or RealPresence Group Series microphones with SoundStructure.

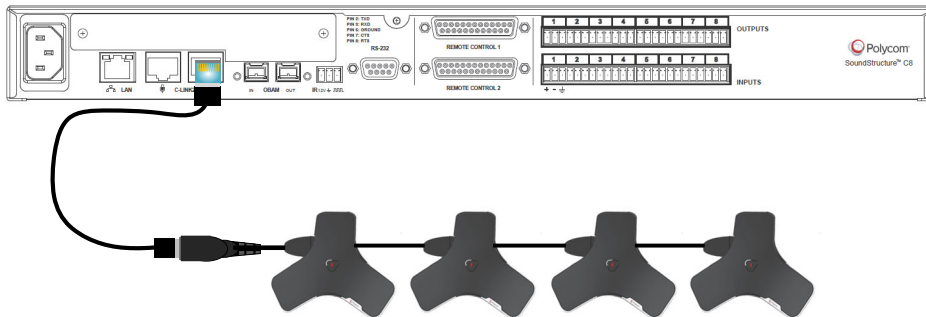

When connecting microphones to Conference Link2 port, connect any HDX or RealPresence Group Series microphones to the **right** Conference Link2 port (when facing the rear panel). Connect the HDX or RealPresence Group Series system to the **left** Conference Link2 port (when facing the rear panel).



When using the Polycom Microphone Cable adapter with RealPresence Group Series or HDX Codecs, make sure the cable is inserted the correct way as the plug and the connector are polarized. If the plug is inserted incorrectly, damage may occur to the SoundStructure and RealPresence Group Series or HDX devices.

Using Multiple SoundStructure Devices with OBAM Link Interface

SoundStructure device has OBAM IN and OUT connectors that may be used to link up to eight SoundStructure devices.

OBAM IN and OUT Connectors

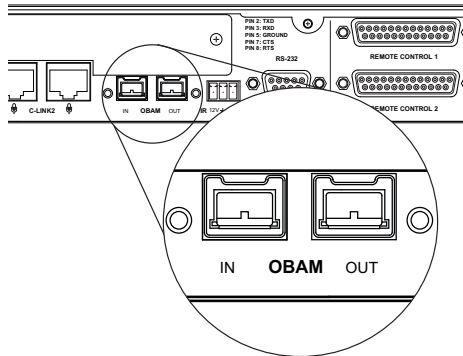

To link multiple SoundStructure devices, connect the OBAM OUT port on the first device (typically the top SoundStructure device in the equipment rack) to the OBAM IN port on the next SoundStructure device as follows.

Linking SoundStructure Devices with the OBAM Connectors

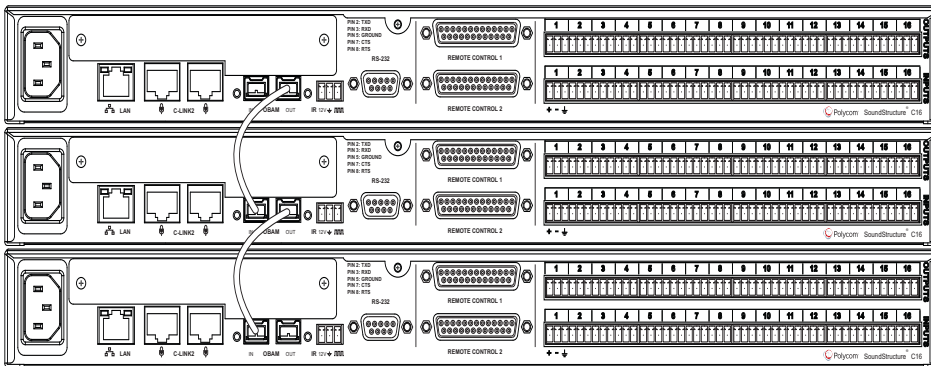

Because the OBAM interface is bi-directional, data will flow in both directions on the single cable between devices. Due to this bi-directionality, do *not* loop the OBAM link connections (as follows).

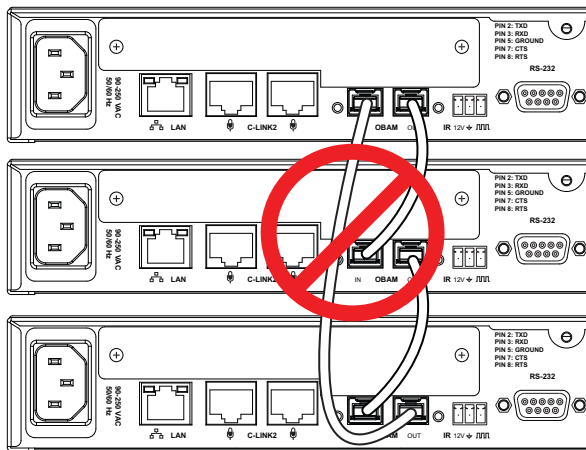

Once the devices are connected over OBAM, the SoundStructure devices will behave as one large audio device, in other words, all the inputs from all the SoundStructure devices are available on all the devices. Any combination of SoundStructure C16, C12, C8, and SR12 devices may be linked together up to a total of eight devices.

When the SoundStructure devices are connected over the OBAM Link, the OBAM Input Status LED illuminates when there is a valid connection between the OBAM IN port on this device and an OBAM OUT port on a second SoundStructure device. This LED will not illuminate unless there is a valid connection between the two devices. The OBAM Output Status LED illuminates when there is a valid connection between the OBAM OUT port on this device and an OBAM IN port on a different SoundStructure device. This LED will not illuminate unless there is a valid connection between the two devices.

A 18-inch OBAM cable (2457-23574-002) is provided with each SoundStructure device. For longer distances, we recommend our 40 ft (12 m) cable (2200-34229-002). See the section [OBAM Link](#) for more details. An OBAM link cable may be tested by inserting the same cable into the OBAM IN and OBAM OUT ports. If the OBAM input and output status LEDs illuminate, the OBAM cable is fully functional.

Device IDs

When multiple devices are connected via the OBAM interface, internal SoundStructure device IDs are assigned automatically based on the OBAM connections. The device that has no OBAM IN connection will be device 1. The device connected to that unit will be device 2, and so on until the last device - the device with no OBAM OUT connection. The device ID is important for ensuring that the devices are sequenced properly so that the hardware matches the configuration that will be uploaded to the system.

As an example, consider the following figure that shows a SoundStructure C12 linked with a C8.

SoundStructure C12 linked to a SoundStructure C8

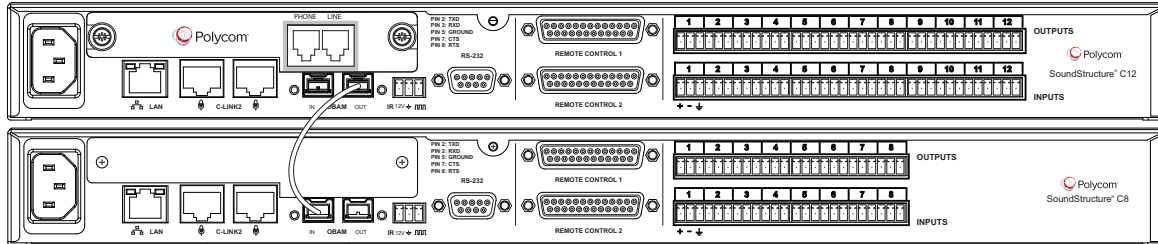

The SoundStructure Studio software can be used to create a design that will be uploaded into the devices. In this example, the configuration file requires devices to be linked together with the C12 as the first device (device ID 1) and the C8 as the second device (device ID 2). The wiring report summarizes the cabling connections for the input and output signals. A typical wiring report generated for the SoundStructure devices is shown in the following text.

This wiring report shows the signal connections to both the SoundStructure C12 at device ID 1, and the SoundStructure C8 at device ID 2. The report also indicates a telephony interface is plugged into the C12 and a Polycom HDX video codec is connected via the C-Link2 interface to the C12. This report also summarizes how the individual inputs and outputs should be connected to the rear-panel of the SoundStructure devices, for instance Table Mic 1 should be connected to input 1 on the SoundStructure C12.

SoundStructure system: SoundStructure System

C12 (bus id: 1)

C-Series Mic Input

- 1: Lectern Mic
- 2: Table Mic 1
- 3: Table Mic 2
- 4: Table Mic 3
- 5: Table Mic 4
- 6: Table Mic 5
- 7: Table Mic 6
- 8: Table Mic 7
- 9: Table Mic 8
- 10: Table Mic 9
- 11: Table Mic 10
- 12: Table Mic 11

C-Series Line Output

- 1: Amplifier (Left)
- 2: Amplifier (Right)

Plugin Card: Single Line Telephone

- 1: Phone In, Phone Out

C-Link2 Interface: Polycom HDX

C8 (bus id: 2)
 C-Series Mic Input
 1: Table Mic 12
 2: Table Mic 13
 3: Table Mic 14
 4: Table Mic 15
 5: Table Mic 16
 6: Wireless Mic
 7: Program Audio (Left)
 8: Program Audio (Right)

Wiring the system as described in the wiring report and linking multiple devices as indicated to ensure the device ID's of the system match the configuration file is an important step to having the system operate properly once the configuration file is uploaded to the devices.

Connecting IR Port to Optional Receiver and RS-232 to Control System

IR Port

The IR receiver port is compatible with IR receivers such as Xantech models 780-80, 780-90, 480-00, 480-80, and 490-00. Terminate the IR receiver into the supplied terminal block using the pinout shown in the following figure. See Chapter 3 of the SoundStructure Design Guide and the software release notes for additional information on how to use the IR receiver port.

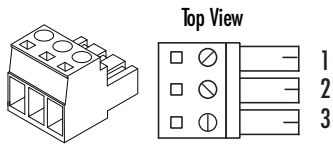

Pin	Signal
1	+12 V
2	Ground
3	IR Signal Data

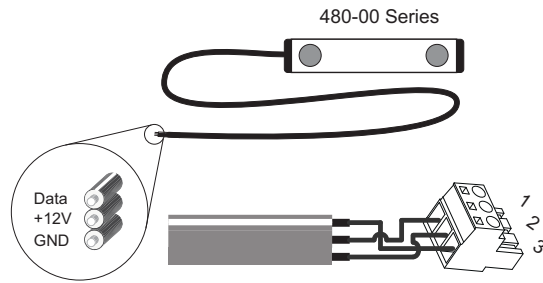

RS-232

The RS-232 interface is capable of running up to 115,200 bps and has a default rate of 9,600 bps, eight data bits, no parity, one stop bit (8-N-1). The pinout of the connection and the recommended straight-through cabling to a control system is shown in the following figure.

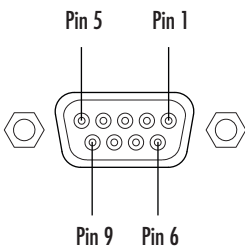

SoundStructure			Control System	
Pin	Signal		Pin	Signal
1	-		1	-
2	TX		2	RX
3	RX		3	TX
4	-		4	-
5	Ground		5	Ground
6	-		6	-
7	CTS		7	RTS
8	RTS		8	CTS
9	-		9	-

At rates at or above 38,400 bps, it is recommended that flow control be enabled on the control system.

The maximum length of an RS-232 cable is determined by the overall capacitance of the cable. For practical purposes, the length of the RS-232 cable should not exceed fifty feet.

Making Audio Connections

SoundStructure devices provide balanced audio input and output connections that are terminated with 3.5 mm terminal blocks. For each balanced analog input or output on the SoundStructure rear-panel, the first pin should be connected to the positive signal, the second pin is connected to the negative signal, and the third pin is chassis ground as shown in the balanced audio connections in the following figure. To connect the SoundStructure device's audio input and output to unbalanced audio equipment, follow the wiring in the unbalanced audio connections below.

Balanced and Unbalanced Audio Connectors

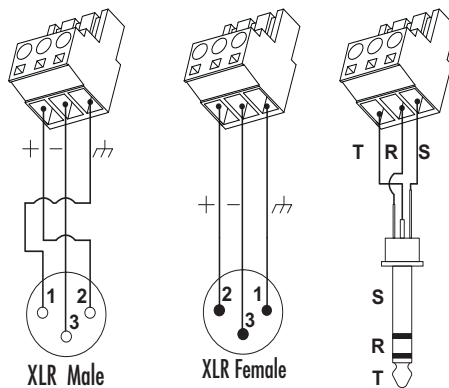

Balanced Audio Connections

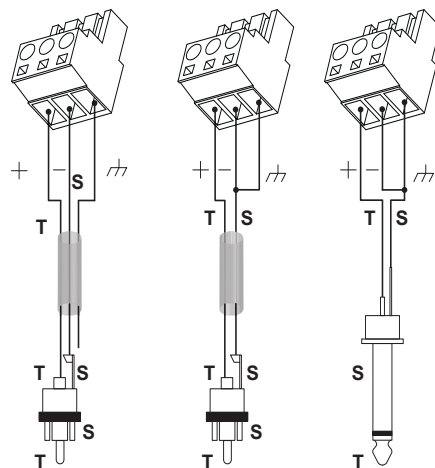

Unbalanced Audio Connections

When using unbalanced audio sources or audio destinations connected to SoundStructure devices, either wiring techniques shown previously for connecting RCA jacks to terminal blocks may be used and both will result in the same voltage level at the tip of the RCA jack.

Connecting Logic Ports

There are two logic ports, called Remote Control 1 and Remote Control 2, on the rear-panel of each SoundStructure device. Please check the software release notes and Chapter 3 of the SoundStructure Design Manual for information concerning logic pin functionality.

Each Remote Control connector includes eleven logic inputs, eleven logic outputs, an analog gain control input, a +5 V supply capable of providing up to 500 mA, and a logic ground. Internal to the SoundStructure device is a fuse that will trigger if the current draw on Pin 1 exceeds 500 mA. The fuse will reset itself once the excessive load is removed.

As there are two logic connectors, there are a total of twenty-two logic inputs, twenty-two logic outputs, two analog gain inputs, and two +5 V supplies and two logic grounds per SoundStructure device. The pinouts and signal definition are shown in the following figures.

Pinouts and Signal Definition

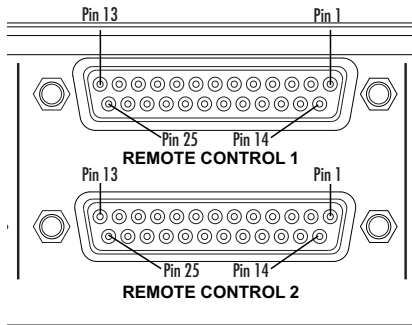

Remote Control 1

Pin	Signal	Pin	Signal
1	+5 V	14	Logic Input 1
2	Logic Output 1	15	Logic Input 2
3	Logic Output 2	16	Logic Input 3
4	Logic Output 3	17	Logic Input 4
5	Logic Output 4	18	Logic Input 5
6	Logic Output 5	19	Logic Input 6
7	Logic Output 6	20	Logic Input 7
8	Logic Output 7	21	Logic Input 8
9	Logic Output 8	22	Logic Input 9
10	Logic Output 9	23	Logic Input 10
11	Logic Output 10	24	Logic Input 11
12	Logic Output 11	25	Ground
13	Analog Gain 1		

Remote Control 2

Pin	Signal	Pin	Signal
1	+5 V	14	Logic Input 12
2	Logic Output 12	15	Logic Input 13
3	Logic Output 13	16	Logic Input 14
4	Logic Output 14	17	Logic Input 15
5	Logic Output 15	18	Logic Input 16
6	Logic Output 16	19	Logic Input 17
7	Logic Output 17	20	Logic Input 18
8	Logic Output 18	21	Logic Input 19
9	Logic Output 19	22	Logic Input 20
10	Logic Output 20	23	Logic Input 21
11	Logic Output 21	24	Logic Input 22
12	Logic Output 22	25	Ground
13	Analog Gain 2		

Logic Inputs

All digital logic inputs (logic inputs 1 - 22) operate as contact closures and may either be connected to ground (closed) or not connected to ground (open). The logic input circuitry is shown in the following figure. Chapter 4 Logic Examples provides examples of how to use the logic input pins.

Logic Input Circuitry

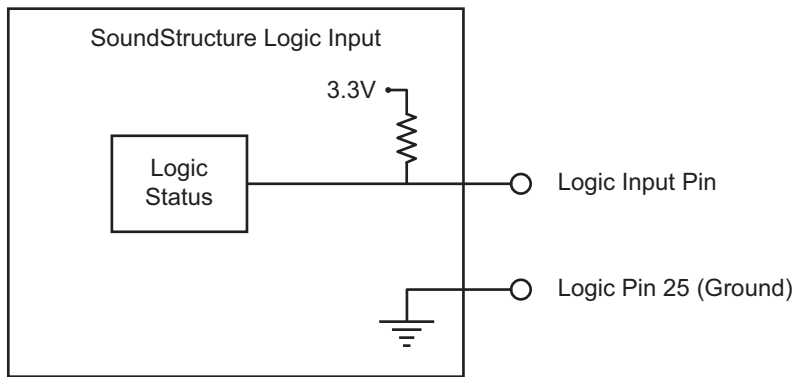

Analog Gain Input

The analog gain inputs (analog gain 1 and 2) operate by measuring an analog voltage between the analog input pin and the ground pin. The maximum input voltage level should not exceed +6 V. It is recommended that the +5 V supply on Pin 1 be used as the upper voltage limit.

The following figure shows the analog gain input pin and the associated +5 V and ground pins that are used with the analog gain input pin. The analog voltage on the analog gain input pin is converted to a digital value via an 8-bit analog-to-digital converter for use within the SoundStructure devices. The maximum voltage value, i.e., 0 dBFS on the analog gain input, is 4.096 V. 0 V is converted to 0 and 4.096 V and above is converted to 255.

The chapter [Logic Examples](#) provides an example of how to use the analog gain input pin.

Analog Gain Input Pin and +5V and Ground Pins

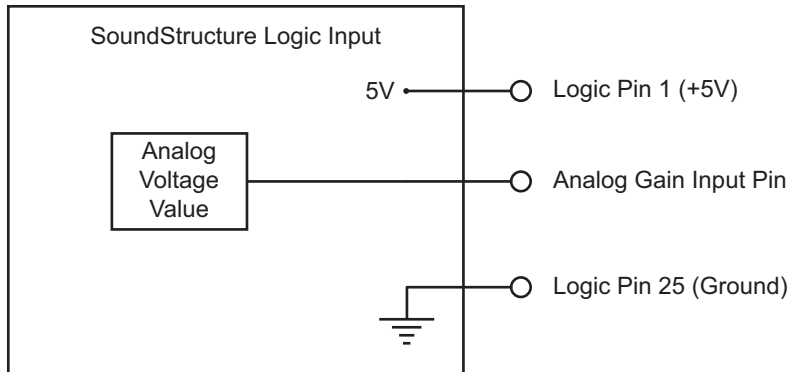

Logic Outputs

All logic outputs are configured as open-collector circuits and may be used with external voltage sources. The maximum voltage that should be used with the logic outputs is 60 V with a maximum current of 500 mA.

Logic Outputs

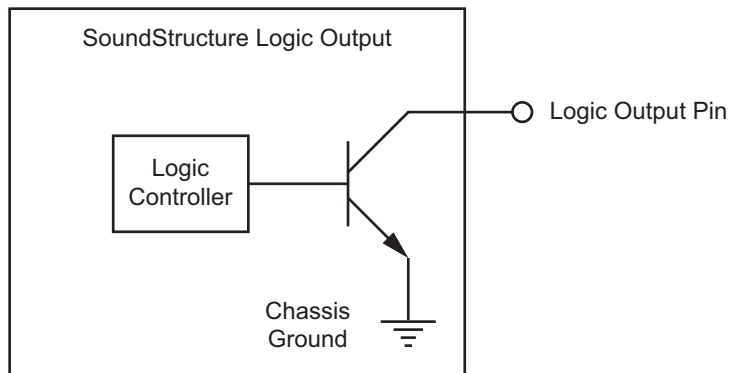

The open collector design is shown in the following figure and works as a switch as follows: when the logic output pin is set **high** (on), the transistor will turn on and the signal connected to the logic output pin will be grounded and current will flow from the logic output pin to chassis ground.

When the logic output is set **low** (off), the transistor will turn off and an open circuit will be created between the logic output and the chassis ground preventing any flow of current, as shown in the following figure.

Logic Output and Chassis Ground Preventing Current Flow

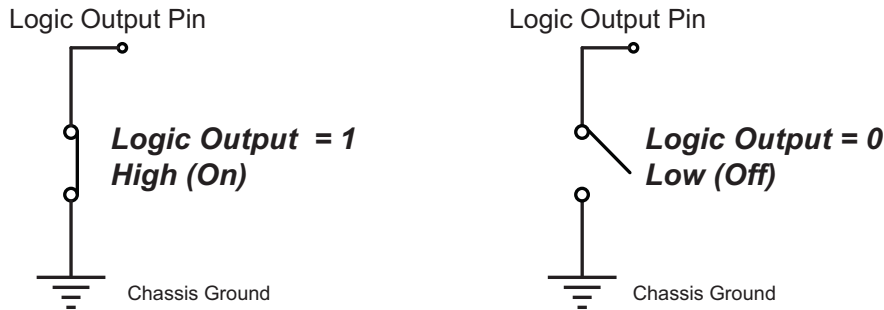

See [Logic Examples](#) for information on how to wire the logic interface for common logic applications.

Powering the System

Connect the AC power line to a grounded AC power main when ready to power the device and plug the other end securely into the rear of the SoundStructure unit. Ensure the plug is securely inserted as shown in the following figure. Upon insertion there will be some initial resistance - continue pushing until the power cord is plugged in.

The SoundStructure units require an AC voltage supply in the range of 90-250 VAC and 50-60 Hz. Power should be applied after any plug-in cards are installed.

As there is no power switch on the SoundStructure devices, once power is connected, the system will begin the boot-up process.

For more information, see [Front-Panel LED Interpretation](#).

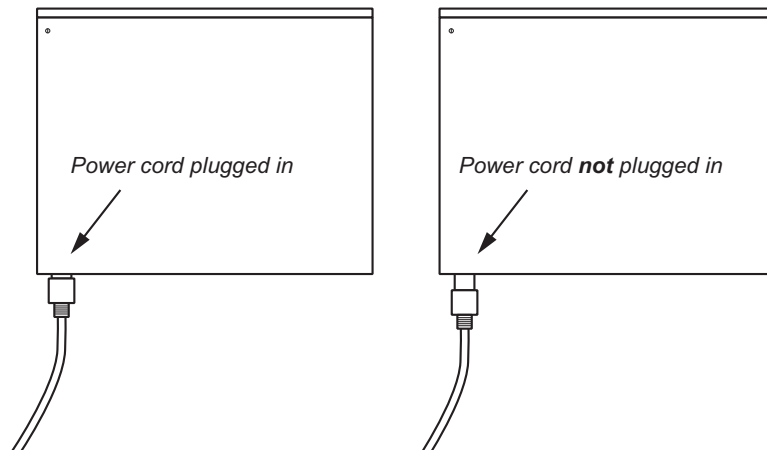

Configuring the SoundStructure Devices

For information on configuring software for the SoundStructure, see the manual entitled *Design Guide for the Polycom SoundStructure C16, C12, C8, and SR12*.

Specifications

Technical Specifications

Dimensions

- 19" (483 mm) W x 13.5" (343 mm) L x 1.75" (45 mm) H (one rack unit)

Weight

- 12 lbs. (5.5 kg) dry, 14 lbs. (6.4 kg) shipping

Connectors

- RS-232: DB9F
- OBAM In/Out: IEEE 1394B
- CLINK2: RJ45
- LAN: RJ45
- Control/Status: DB25F
- Audio: Mini (3.5 mm) quick connect terminal blocks
- IR Receive: Mini (3.5 mm) quick connect terminal block

Power

- Internal power supply
- Input voltage of 100-240 VAC; 50-60 Hz
- Line power requirements (including 0.6 PF): 130 VA (C16), 115 VA (C12), 105 VA (SR12), 95 VA (C8)

Thermal

- Thermal Dissipation (Btu/hr): 266 Btu/hr (C16), 230 Btu/hr (C12), 215 Btu/hr (SR12), 200 Btu/hr (C8)
- Operating temperature 0 - 40° C (104° F)

Operating temperature ranges for the three thermal sensors located on the SoundStructure device are shown in the following table. These sensor values are found on the Wiring page within SoundStructure Studio when connected to a SoundStructure device. Green indicates normal operation up to the temperatures listed in the following table. Yellow indicates an elevated temperature that is acceptable but the ambient temperature and airflow in the system should be checked. Red indicates an over-temperature event that must be corrected for proper operation of the SoundStructure device.

Thermal Sensors' Operating Temperature Ranges

Sensor	Normal (Green)	Warning (Yellow)	Error (Red)
1	50° C	59° C	60+ ° C
2	69° C	79° C	80+° C
3	53° C	58° C	59+° C

Inputs

- Phantom power: 48 V DC through 6.8 kOhm series resistor per leg, 7.5 mA per audio channel, software selectable
- Analog input gain: -20 to 64 dB on all inputs in 0.5 dB steps, software adjustable
- Maximum input amplitude: +20.4 dBu, 1% THD + N
- Nominal level: 0 dBu (0.775 Vrms)
- Equivalent input noise: <-122 dBu, 20-20,000 Hz, Rs=150 Ohms (1%)
- Input impedance: 10 kOhms
- Input EMI Filter: Pi filter on all audio inputs

Outputs

- Output gain: -100 to 20 dB in 1 dB steps, software adjustable
- Maximum output amplitude: +23 dBu, 1% THD + N
- Nominal output level: 0 dBu (0.775 Vrms)
- Output impedance: 50 Ohm, each leg to ground, designed to drive loads > 600 Ohms
- Output EMI filter: Pi filter on all audio outputs

System



Valid values for all channels

Unless noted, all values are valid for all channels at 0 dB input gain.

- Frequency response: 20-22,000 Hz, + 0.1 /- 0.3 dB
- Idle channel noise: <-109 dB FS no weighting, 20-20,000 Hz, -60dB FS, 997 Hz input signal, 0 dB gain
- Dynamic range: >109 dB FS no weighting, 20 - 20,000 Hz, -60 dB FS, 997 Hz input signal, 0 dB gain
- Linearity: 0 dB FS to -122 dB FS +/- 1 dB
- THD+N: < 0.005%, -20 dB FS input signal
- Common mode rejection ratio: <-61 dB, 20-20,000 Hz, no weighting
- Cross talk: <-110 dB, 20-20,000 Hz, 1kHz, channel-to-channel
- Latency: Mic/Line inputs to outputs: 20 ms, AEC and NC processing enabled
- Acoustic echo cancellation span: 260 ms

- Total cancellation: >65 dB
- Convergence rate: 40 dB/second
- Noise cancellation: 0-20 dB, software selectable
- Control inputs: contact closure
- Status outputs: open collector 60 V and 500 mA maximum total per outputs
- All signal ground pins connected to chassis ground through low impedance planes

Telco

- Input gain: -100 to +20 dB in 1 dB steps, software adjustable
- Nominal transmit level: 0 dBu in SoundStructure device yields -15 to -17 dBm to phone (country code dependent)
- Off hook loop current: 10 mA (minimum) to 120 mA (maximum)
- Output gain: -100 to +20 dB in 1 dB steps, software adjustable
- Frequency response: 250-3300 Hz
- Dynamic range: >70 dB FS, 250-3300 Hz, "A" weighted

Pin Out Summary



Drawings and part numbers are provided for reference only

Other than cables provided by Polycom, Polycom claims no responsibility or liability for the quality, performance, or reliability of cables based on these reference drawings. Contact a Polycom reseller to order cables that meet the appropriate manufacturing tolerances, quality, and performance parameters for particular applications.

Conference Link2

To build a custom Conference Link2 cable, use shielded CAT5e, or better, and terminate both end connectors, P1 and P2, with standard 8P8C plugs (for example, RJ45) using the wiring connections shown in the following figure. The maximum length for this cable is 100 feet (30 m). Note that this cable provides a cross-over connection between pins 1 and 2 and pins 5 and 6.

Conference Link2 Wiring Connections

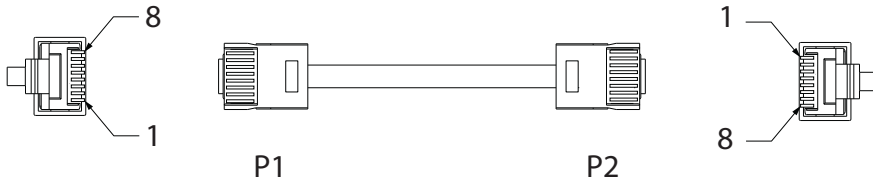

COLOR	AWG	P1		P2
WHITE/GREEN	24	1		5
GREEN	24	2		6
WHITE/ORANGE	24	5		1
ORANGE	24	6		2
WHITE/BROWN	24	7		7
BROWN	24	8		8
DRAIN WIRE	24	3		3
SHIELD		SHELL		SHELL

P1 - RJ-45 shielded Keystone jack, L-com RJ110C5-S or equivalent,
or

P1 - RJ-45 shielded plug, Tyco 5-569552 or equivalent with shielded RJ-45 panel coupler kit (L-com ECF504-SC5E or equivalent).

P2- RJ-45 shielded plug, Tyco 5-569552 or equivalent.

OBAM Link

The OBAM cable is a standard 1394b BETA style cable. The 18 in cable (2457-23574-002) ships with the SoundStructure device. For longer distances, you can purchase our 40 ft (12 m) cable (2200-34229-002).

While OBAM Link uses 1394b cables, the underlying bus protocol is not IEEE1394b compliant which means that external IEE1394b devices will not be compatible with OBAM Link. Using IEE1394b hubs or repeaters will not extend the length of OBAM and any non-SoundStructure approved device that is placed on the OBAM Link will prevent OBAM Link from operating properly.

OBAM Cable

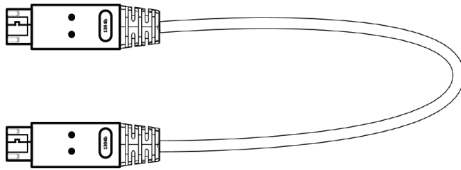

OBAM Port

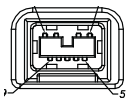

Connector Pinout

1394b BETA Plug		1394b BETA Plug
1		3
2		4
9		5
3		1
4		2
5		9
6		6
8		8
SHELL		SHELL



Connector pinouts
Pin 7 is not connected.

IR Receiver

The IR receiver port on the rear-panel of a SoundStructure device is shown in the following figure.

IR Receiver Port

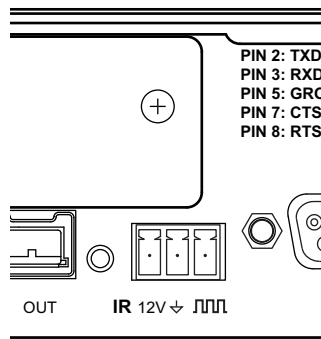

The IR receiver port accepts a standard 3.5 mm terminal block which should be terminated to the IR receiver as shown in the following figures.

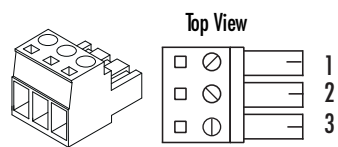

Pin	Signal
1	+12 V
2	Ground
3	IR Signal Data

RS-232

The RS-232 interface requires a straight-through cabling to a control system as shown in the following figures.

SoundStructure Pins

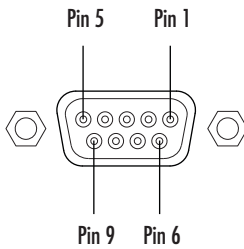

SoundStructure Pin and Signal Control System

SoundStructure			Control System	
Pin	Signal		Pin	Signal
1	-		1	-
2	TX		2	RX
3	RX		3	TX
4	-		4	-
5	Ground		5	Ground
6	-		6	-
7	CTS		7	RTS
8	RTS		8	CTS
9	-		9	-

Logic Interface

Remote Controls 1 and 2

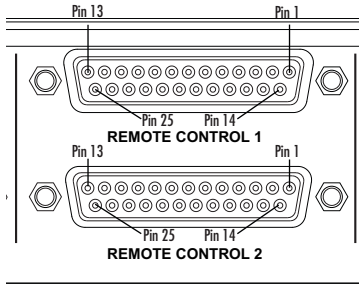

Remote Control 1

Pin	Signal	Pin	Signal
1	+5 V	14	Logic Input 1
2	Logic Output 1	15	Logic Input 2
3	Logic Output 2	16	Logic Input 3
4	Logic Output 3	17	Logic Input 4
5	Logic Output 4	18	Logic Input 5
6	Logic Output 5	19	Logic Input 6
7	Logic Output 6	20	Logic Input 7
8	Logic Output 7	21	Logic Input 8
9	Logic Output 8	22	Logic Input 9
10	Logic Output 9	23	Logic Input 10
11	Logic Output 10	24	Logic Input 11
12	Logic Output 11	25	Ground
13	Analog Gain 1		

Remote Control 2

Pin	Signal	Pin	Signal
1	+5 V	14	Logic Input 12
2	Logic Output 12	15	Logic Input 13
3	Logic Output 13	16	Logic Input 14
4	Logic Output 14	17	Logic Input 15
5	Logic Output 15	18	Logic Input 16

Remote Control 2

6	Logic Output 16	19	Logic Input 17
7	Logic Output 17	20	Logic Input 18
8	Logic Output 18	21	Logic Input 19
9	Logic Output 19	22	Logic Input 20
10	Logic Output 20	23	Logic Input 21
11	Logic Output 21	24	Logic Input 22
12	Logic Output 22	25	Ground
13	Analog Gain 2		

Audio Connections

SoundStructure devices provide balanced audio input and output connections that are terminated with 3.5 mm terminal blocks as shown in the following figure.

3.5 MM Terminal Block

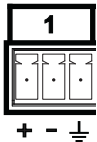

For each balanced analog input or output on the SoundStructure rear-panel, the first pin should be connected to the positive signal, the second pin is connected to the negative signal, and the third pin is chassis ground as shown in the balanced audio connections in the following figure. To connect the SoundStructure device's audio input and output to other balanced or unbalanced audio equipment, follow the wiring convention in the unbalanced audio connections following figure.

Balanced and Unbalanced Audio Connections

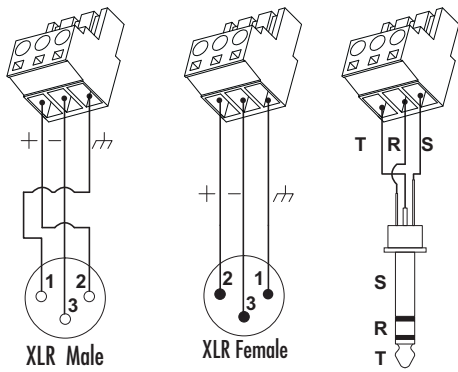

Balanced Audio Connections

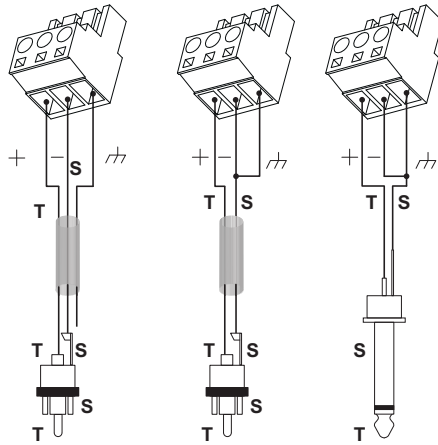

Unbalanced Audio Connections

Logic Examples

Logic Input

Contact Closure

When the contact is closed, the logic input pin (Pin 14 in the example below) is driven low (0 or off). When the switch is open, the logic input pin will float high (1 or on).

Typical applications may be push to mute or push to talk buttons or room combining for changing the device settings based on the room configuration.

Contact Closure

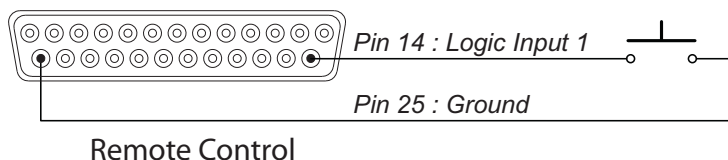

Logic Output

SoundStructure Powered Relay

Relays rated for +5 V or lower may be driven directly from the +5 V logic connector pin 1 supply. Relays rated for more than +5 V will need an external power supply as described in the next example.

When the logic output (Pin 2 in this example) is set on (1 or high), current flows from Pin 2 to ground and current that flows will energize the relay coil and close the relay contact. When the logic output is set off (0 or low), current will stop flowing to the relay coil, causing the relay contact to open. A diode is recommended to be placed in parallel with the relay to provide a path for the discharge current of the magnetic coil of the relay. This current will discharge over a very short period of time and a diode capable of handling a large amount of surge current such as the 1N4001 is recommended and is available from several manufacturers.

This example circuit uses an Omron G5CA relay and the coil resistance is 125 ohms. Because of this coil resistance, an additional series resistor is not required to limit the current from the 5 V supply to less than 500 mA in this example.

SoundStructure Powered Relay

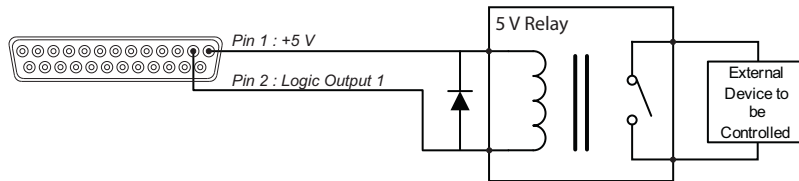

Externally Powered Relay

SoundStructure can be used with externally powered relays when the following conditions exist:

- The relay is DC powered.
- The DC voltage does not exceed 60 V.
- The current from the power supply and relay circuit does not exceed 500 mA.

Externally Powered Relay

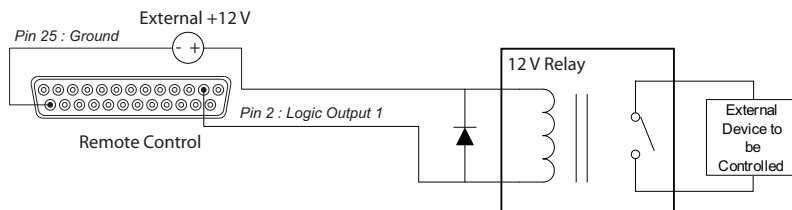

As with the 5 V relay example, when the logic output pin (Pin 2 in the above example) is set on (1 or high), the relay energizes and the relay contact is closed. When the logic output in is set off (0 or low), current stops flowing, and the relay de-energizes and the relay contact is opened.

A diode is recommended to be placed in parallel with the relay to provide a path for the discharge of the magnetic coil of the relay. This current will discharge over a very short period of time and a diode capable of handling a large amount of surge current such as the 1N4001 is recommended and is available from several manufacturers. The 1N4001 is rated up to 50 V, if higher voltages are required, the 1N4002 is rated to 100 V.

This circuit uses an Omron G7L 12 V relay with a coil resistance of 75 ohms. For this reason, an additional series resistor between the power supply and relay is not needed to ensure the current from the 5 V supply is less than 500 mA.

The ground connection of the power supply must be connected to the ground pin of the logic connector (Pin 25) in order for the return currents from the external power supply to be able to return to their source.

Driving an LED

SoundStructure logic outputs can be used to turn on or off LEDs. In this example when the logic output is driven on (1 or high), current will flow, and the LED will turn on. When the logic output is set off (0 or low), current will stop flowing, and the LED will turn off.

Most standard LEDs need about 2.0 V to illuminate. In this example a 274 ohm resistor is used to limit the current from Pin 1.

A series resistor must be used to limit the voltage and current to a safe level for the LED.

Increasing the series resistor value will decrease the current through the circuit and will also decrease the voltage at the input to the LED, reducing the brightness of the LED.

Driving an LED

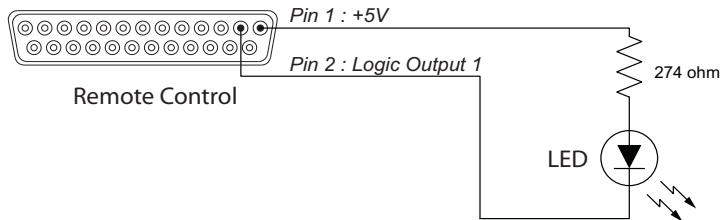

Logic Input and Output

Push To Talk Microphones

The SoundStructure devices may be used with push to talk microphones such as the Shure MX392.

When the orange (LED in) wire is connected to ground due to the SoundStructure logic output being turned on, the LED on the microphone will turn on. The LED is powered from the SoundStructure phantom power supply on the red and black cables. This means that the LED on the microphone does not need external power through a pull-up resistor on the orange (LED in) wire. The shield of the cable provides a ground for the entire audio and logic circuit even though there is a separate green wire for Logic Ground. This means that the green wire does not need to be connected to SoundStructure device. One could connect the green wire to the shield at the mic side and then only need to run a 4-conductor cable plus shield to the SoundStructure device, or one could run the microphone's logic ground to the ground on the logic connector.

No current-limiting resistors are needed between the microphone and the SoundStructure device as the current on the Orange (LED IN) wire when the LED is on is on the order of microamps.

Push to Talk Microphone

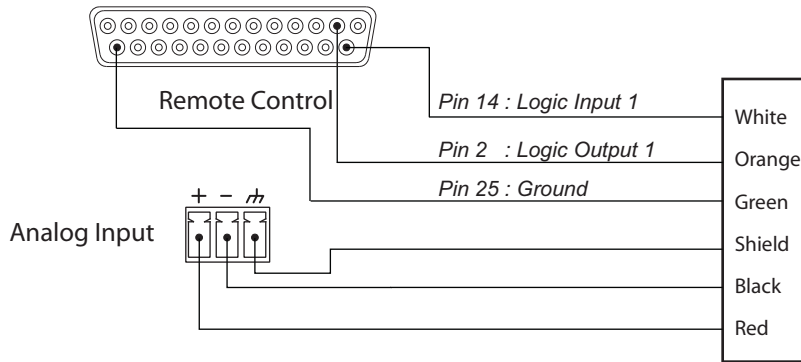

Analog Gain Control

Pin 13 on each Remote control connector may be used with an analog potentiometer to provide an analog input signal that can be used to control volume or other settings within SoundStructure devices.



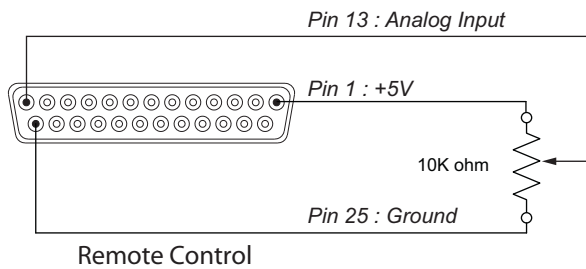

Analog Gain Control

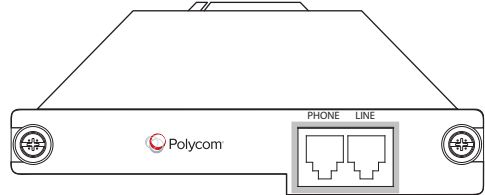
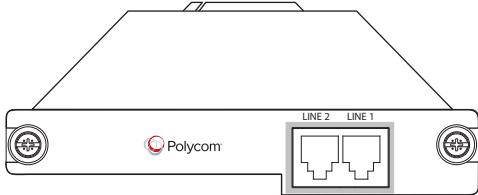
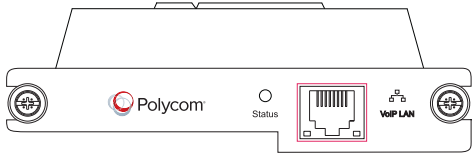
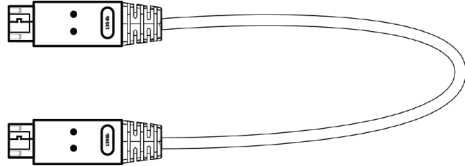

Accessories

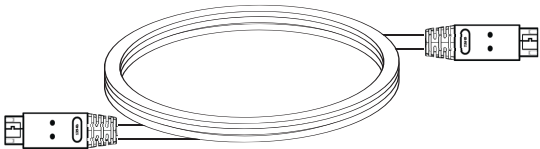
The SoundStructure product family includes the following accessories, which can be purchased separately. See the *SoundStructure Accessory Guide* on [Polycom Voice Support](#) for an up to date collection of SoundStructure product accessories.

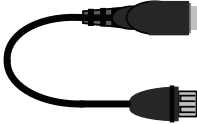
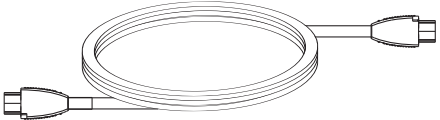
Accessory	Accessory Graphic
Single-Line PSTN Interface 2200-35003-001	
Dual-Line PTSN interface 2200-35004-001	
SoundStructure VoIP Interface 2200-35005-001	
Conference Link2 Cable (18") 2457-23574-002	

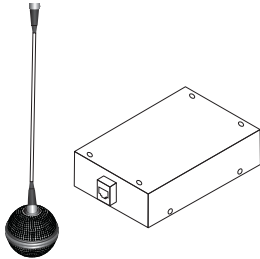
Accessory	Accessory Graphic
<p>OBAM Cable (40') 2200-34229-002</p>	 <p>A coiled cable with two RJ45 connectors at each end.</p>
<p>Polycom RealPresence Group Series Microphone Array 2215-63885-001</p>	 <p>A black, Y-shaped microphone array with a central red indicator light.</p>
<p>Polycom Microphone Cable Adapter 2457-25646-001</p>	 <p>A short black cable with a standard RJ45 connector on one end and a specialized microphone connector on the other.</p>
<p>Polycom HDX Microphone Cable 25 ft. 2457-23216-001</p>	 <p>A coiled cable with two RJ45 connectors at each end.</p>
<p>Polycom HDX Microphone Cable 15 ft. 2457-23215-001</p>	 <p>A coiled cable with two RJ45 connectors at each end.</p>
<p>Polycom Ceiling Microphone Array 2200-23809-001 (Black) 2200-23809-002 (White)</p>	 <p>A ceiling microphone array consisting of a spherical microphone head on a thin stem, and a rectangular mounting box with a connector on the side.</p>

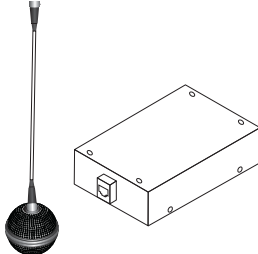
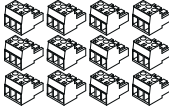
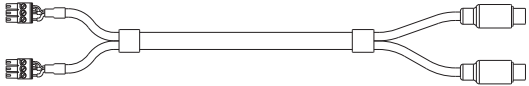
Accessory	Accessory Graphic
Polycom Ceiling Microphone Extension Kit 2200-23810-001 (Black) 2200-23810-002 (White)	
Terminal Blocks 2215-80031-001	
Audio Adapter Cable 2457-23492-001	

Regulatory Notices And Warranty Information

Regulatory Notices

USA And Canada

Pt 15 Rules

This device complies with part 15 of the FCC Rules. Operation is subject to the following two conditions: This device may not cause harmful interference, and this device must accept any interference received, including interference that may cause undesired operation.

Class A Digital Device Or Peripheral

NOTE: This equipment has been tested and found to comply with the limits for a Class A digital device, pursuant to part 15 of the FCC Rules. These limits are designed to provide reasonable protection against harmful interference when the equipment is operated in a commercial environment. This equipment generates, uses, and can radiate radio frequency energy and, if not installed and used in accordance with the instruction manual, may cause harmful interference to radio communications. Operation of this equipment in a residential area is likely to cause harmful interference in which case the user will be required to correct the interference at his own expense.

Modifications

In accordance with part 15 of the FCC rules, the user is cautioned that any changes or modifications not expressly approved by Polycom Inc. could void the user's authority to operate the equipment.

Exhibit J - Customer Information

This equipment complies with Part 68 of the FCC rules and the requirements adopted by the ACTA. On the exterior of the cabinet of this equipment is a label that contains, among other information, a product identifier in the format **2HWTE01BSSTRUCTURE**. If requested, this number must be provided to the telephone company.

- ACTA Registration Number: **2HWTE01BSSTRUCT**
- Ringer Equivalence Number (REN): 0.1B
- Facility Interface Code (FIC): 02LS2
- Service Order Code (SOC): 9.0Y
- USOC Jack Type: RJ11C

A FCC compliant telephone cord and modular plug is provided with this equipment. This equipment is designed to be connected to the telephone network or premises wiring using a compatible modular jack that is Part 68 compliant. See Installation Instructions for details.

The REN is used to determine the quantity of devices that may be connected to the telephone line. Excessive RENs on the telephone line may result in the devices not ringing in response to an incoming call. Typically, the sum of RENs should not exceed five (5.0). To be certain of the number of devices that may be connected to a line (as determined by the total RENs) contact the local telephone company.

If this equipment Polycom SoundStructure TEL 1 and SoundStructure TEL 2 causes harm to the telephone network, the telephone company will notify you in advance that temporary discontinuance of service may be required. But if advance notice isn't practical, the telephone company will notify the customer as soon as possible. Also, you will be advised of your right to file a complaint with the FCC if you believe it is necessary.

The telephone company may make changes to its facilities, equipment, operations or procedures that could affect the operation of the equipment. If this happens the telephone company will provide advance notice so you can make the necessary modifications to maintain uninterrupted service.

If trouble is experienced with this equipment Polycom SoundStructure TEL 1 and SoundStructure TEL 2, for repair or warranty information, please contact Polycom Inc., 4750 Willow Road, Pleasanton, CA 94588-2708 USA 408.526.9000. If the equipment is causing harm to the telephone network, the telephone company may request that you disconnect the equipment until the problem is resolved.

Connection to party line service is subject to state tariffs. (Contact the state public utility commission, public service commission or corporation commission for information.)

Data Equipment

The table below shows which jacks are associated with which modes of operation:

Mode of Operation	USOC Jack
Permissive	RJ11C

Automatic Dialing

WHEN PROGRAMMING EMERGENCY NUMBERS AND/OR MAKING TEST CALLS TO EMERGENCY NUMBERS;

- Remain on the line and briefly explain to the dispatcher the reason for the call.
- Perform such activities in the off-peak hours, such as early morning or late evening.

Canada

Canadian EMC Class A

English Statement:

This Class [A] digital apparatus complies with Canadian ICES-003.

French Statement:

Cet appareil numérique de la classe [A] est conforme à la norme NMB-003 du Canada.

This product meets the applicable Industry Canada technical specifications.

The **Ringer Equivalence Number** (REN) assigned to each relevant terminal device provides an indication of the maximum number of terminals allowed to be connected to a telephone interface. The termination on

an interface may consist of any combination of devices subject only to the requirement that the sum of the Ringer Equivalence Numbers of all the devices does not exceed 5.

The REN of this equipment is either marked on the unit or included in the new style USA (FCC registration number). In the case that the REN is included in the FCC number the user should use the following key to determine the value:

The FCC number is formatted as US: AAAEQ##TXXX.

is the Ringer Equivalence Number without a decimal point (e.g. REN of 1.0 = 10, REN of 0.3 = 03). In the case of a "Z" ringer, ZZ shall appear. In the case of approved equipment without a network interface and equipment not connecting to circuits with analog ringing supplied then "NA" shall appear.

EEA (European Economic Area) Including Switzerland

CE Mark

This SoundStructure has been marked with the CE mark. This mark indicates compliance with with all applicable CE marking directives. A full copy of the EU declaration of conformity can be obtained from Polycom (Netherlands) BV, Orlyplein 10, 23rd Floor 1043DP, Amsterdam, Netherlands.

Australia

Mains powered POT's Voice Telephony without Emergency 000 dialing

Warning:

This equipment will be inoperable when mains power fails.

Reference: AS/ACIF S002:2001 (incorporating Amdt 1) DECEMBER 2001

Clause 5.1.8.4 Provision of power-fail advice

Japan (VCCI)

この装置は、クラスA情報技術装置です。この装置を家庭環境で使用すると電波妨害を引き起こすことがあります。この場合には使用者が適切な対策を講ずるよう要求されることがあります。

VCCI-A

Korea

Class A

사용자안내문(제 5 조제 1 항제 2 호관련)

A 급 기기 (업무용 방송통신기기)

이 기기는 업무용(A 급)으로 전자과적합등록을 한 기기이오니 판매자 또는 사용자는 이 점을 주의하시기 바라며, 가정외의 지역에서 사용하는 것을 목적으로 합니다.

New Zealand

General Warning:

The grant of a Telepermit for any item of terminal equipment indicates only that Telecom has accepted that the item complies with minimum conditions for connection to its network. It indicates no endorsement of the product by Telecom, nor does it provide any sort of warranty. Above all, it provides no assurance that any item will work correctly in all respects with another item of Telepermitted equipment of a different make or model, nor does it imply that any product is compatible with all of Telecom's network services.

Important Notice:

Under power failure conditions, this telephone may not operate. Please ensure that a separate telephone, not dependent on local power, is available for emergency use.

Russia

The manufacture of this product is Polycom USA.

6001 America Center Drive
San Jose, CA 95002
USA
enquiries@polycom.com
+1 925 924 6000

Polycom LLC is the authorized representative.

Polycom (Russia)
Paveletskaya Square
Bld.2, Block 2, 23rd Floor
Business Center "Paveletskaya Plaza"
Moscow
Tel: +7 495 213 1237
alexey.gorbunov@polycom.com

EMC Class A Device:

The SoundStructure C Series and SR Class A products, which meet standards for use in business, industrial and commercial settings, are not intended to be used in residential environments.

Safety Considerations for Storage and Transportation

- SoundStructure products have a 7 year period of life.
- SoundStructure products have a 7 year period of storage.
- SoundStructure products have a -30C to 60C/ 35 ~90% RH non-condensing at 40C storage requirement.
- SoundStructure products have a -30C to 60C/ 35 ~90% RH non-condensing at 40C transportation requirement.

Recycling

End of Life Products

Polycom encourages you to recycle your end-of-life Polycom products in an environmentally considerate way. In accordance with the requirements of the European Waste Electronic and Electrical Equipment (WEEE) Directive, all Polycom products are marked with the crossed wheelie bin symbol. Products that carry this symbol should not be disposed of in the household or general waste stream. Detail of the options open to you and the guidance on the requirements for the recycling and environmentally considerate disposal of your end of life. Polycom products can be found at <http://www.polycom.com/WEEE>.

Documentation

Polycom, Inc. has a right to change the *Polycom SoundStructure Hardware Installation Guide* without prior notification.

Troubleshooting

This section provides information about actions required if the product does not work correctly.

- To search for answers in product documentation, see [Search for Answers in the Product Documentation](#).
- To use the Knowledge Base, see [Use the Knowledge Base](#).
- To access Polycom Technical Support, see [Access Polycom Technical Support](#).

Additional information, user guides, and software updates are available at support.polycom.com.

Search for Answers in the Product Documentation

You can find Polycom product documentation at support.polycom.com. Under **Documents and Downloads**, select **Voice > SoundStructure**, and search for the document you want. For Troubleshooting tips, see the Troubleshooting chapter in the *Polycom SoundStructure Design Guide*.

Use the Knowledge Base

For more troubleshooting information, search the Knowledge Base at [Polycom Support](#).

Access Polycom Technical Support

If you are not able to make test calls successfully and you have verified that the equipment is installed and set up correctly, contact your Polycom distributor or Polycom Technical Support. To contact Polycom Technical Support, go to [Polycom Support](#) web site.

Product Manufacturing Information

This section includes manufacturing information for Polycom SoundStructure C8, SoundStructure C12, SoundStructure C16, and SoundStructure SR12.

Country of Manufacture

The country of manufacture is Thailand.

Sales Terms and Conditions

Sales terms and conditions are stated in the agreements with authorized distributors.

Month and Year of Production

The fields YYYYMMDDLL include the month, year, and location of production, and is located on the bottom of the SoundStructure device with the Serial number. The following table provides a description of each field for production.

Month and Year Fields

Field	Field Description
YYYY	Production year. This is the year during which the unit was manufactured.
MM	Production month. There are twelve months in a year, therefore these two digits will line in the range between 01-12.
DD	Production day. There are up to thirty one days in a month, therefore these two digits will lie in the range between 01-31.
LL	Location code. This is used to determine the factory where the unit was produced.

South Africa

Important Notice to South African customers:

Polycom recommends the use of an external surge suppressor when using the SoundStructure TEL1 or TEL2 plug-in cards.

A standard DM surge protector (Telkom license number MIS/19) is available from:

Design Modifications CC

Att: Petrus Geyser

P.O. Box 15245

Sinoville 0129

South Africa

Tel: (082) 452 0269

Fax: (012) 711 0872

Taiwan

For connection in Taiwan, Polycom requires the use of external surge protection on the PSTN telecommunication interfaces connected to the TEL1 and TEL2 cards.

Polycom recommends the APC (American Power Conversion) ProtectNet PTEL2 for this purpose. Details may be found at www.apc.com.

For use with the TEL2 interface card, the PTEL2 device will provide protection for both lines if a cable with the following pinout is used on both sides of the surge protector:

RJ45 pin 3 and 4 to RJ11 (6 pin) pin 3 and 4

RJ45 pin 5 and 6 to RJ11 (6 pin) pin 3 and 4.

For use with the TEL1 interface card, the PTEL2 device will provide protection for the PSTN line if a cable with the following pinout is used on both sides of the surge protector:

RJ45 pin 3 and 4 to RJ11 (6 pin) pin 3 and 4.



Properly Connect the Surge Suppressor

The surge suppressor is directional and must be connected in accordance with the supplied instructions. The connection of the earth lead on the surge suppressor to an effective earth bonding point is a requirement of its correct operation.

Rest Of World

EMC. CLASS A ITE

WARNING

This is a Class A product. In a domestic environment this product may cause radio interference in which case the user may be required to take adequate measures.

Installation Instructions

Installation must be performed in accordance with all relevant national wiring rules

Plug acts as Disconnect Device

The socket outlet to which this apparatus is connected must be installed near the equipment and must always be readily accessible

Warranty Information

LIMITED WARRANTY

Polycom warrants to the end user ("Customer") that the product will be free from defects in workmanship and materials, under normal use and service, for one year, or such longer period as Polycom may announce

publicly from time to time for particular products, from the date of purchase from Polycom or its authorized reseller.

Polycom's sole obligation under this express warranty shall be, at Polycom's option and expense, to repair the defective product or part, deliver to Customer an equivalent product or part to replace the defective item, or if neither of the two foregoing options is reasonably available, Polycom may, in its sole discretion, refund to Customer the purchase price paid for the defective product. All products that are replaced will become the property of Polycom. Replacement products or parts may be new or reconditioned. Polycom warrants any replaced or repaired product or part for ninety (90) days from shipment, or the remainder of the initial warranty period, whichever is longer.

Products returned to Polycom must be sent prepaid and packaged appropriately for safe shipment and it is recommended that they be insured or sent by a method that provides for tracking of the package. Responsibility for loss or damage does not transfer to Polycom until the returned item is received by Polycom. The repaired or replaced item will be shipped to Customer, at Polycom's expense, not later than thirty (30) days after Polycom receives the defective product, and Polycom will retain risk of loss or damage until the item is delivered to Customer.

EXCLUSIONS. POLYCOM WILL NOT BE LIABLE UNDER THIS LIMITED WARRANTY IF ITS TESTING AND EXAMINATION DISCLOSE THAT THE ALLEGED DEFECT OR MALFUNCTION IN THE PRODUCT DOES NOT EXIST OR RESULTS FROM:

- FAILURE TO FOLLOW POLYCOM'S INSTALLATION, OPERATION, OR MAINTENANCE INSTRUCTIONS.
- UNAUTHORIZED PRODUCT MODIFICATION OR ALTERATION.
- UNAUTHORIZED USE OF COMMON CARRIER COMMUNICATION SERVICES ACCESSED THROUGH THE PRODUCT.
- ABUSE, MISUSE, NEGLIGENT ACTS OR OMISSIONS OF CUSTOMER AND PERSONS UNDER CUSTOMER'S CONTROL; OR
- ACTS OF THIRD PARTIES, ACTS OF GOD, ACCIDENT, FIRE, LIGHTING, POWER SURGES OR OUTAGES, OR OTHER HAZARDS.

WARRANTY EXCLUSIVE. IF A POLYCOM PRODUCT DOES NOT OPERATE AS WARRANTED ABOVE, CUSTOMER'S SOLE REMEDY FOR BREACH OF THAT WARRANTY SHALL BE REPAIR, REPLACEMENT, OR REFUND OF THE PURCHASE PRICE PAID, AT POLYCOM'S OPTION. TO THE FULL EXTENT ALLOWED BY LAW, THE FOREGOING WARRANTIES AND REMEDIES ARE EXCLUSIVE AND ARE IN LIEU OF ALL OTHER WARRANTIES, TERMS, OR CONDITIONS, EXPRESS OR IMPLIED, EITHER IN FACT OR BY OPERATION OF LAW, STATUTORY OR OTHERWISE, INCLUDING WARRANTIES, TERMS, OR CONDITIONS OF MERCHANTABILITY, FITNESS FOR A PARTICULAR PURPOSE, SATISFACTORY QUALITY, CORRESPONDENCE WITH DESCRIPTION, AND NON-INFRINGEMENT, ALL OF WHICH ARE EXPRESSLY DISCLAIMED. POLYCOM NEITHER ASSUMES NOR AUTHORIZES ANY OTHER PERSON TO ASSUME FOR IT ANY OTHER LIABILITY IN CONNECTION WITH THE SALE, INSTALLATION, MAINTENANCE OR USE OF ITS PRODUCTS.

SUPPORT & SERVICE AGREEMENTS. If you purchased your product from a Polycom Authorized Reseller, contact the Authorized Reseller for information about support and service agreements applicable to your product.

For information on Polycom service, go to the Polycom web site www.polycom.com, products and services menu, or call 1-800-765-9266, outside the US call 1-408-526-9000, or your local Polycom Office, as listed on the Polycom Web site.

LIMITATION OF LIABILITY. TO THE FULL EXTENT ALLOWED BY LAW, POLYCOM EXCLUDES FOR ITSELF AND ITS SUPPLIERS ANY LIABILITY, WHETHER BASED IN CONTRACT OR TORT

(INCLUDING NEGLIGENCE), FOR INCIDENTAL, CONSEQUENTIAL, INDIRECT, SPECIAL, OR PUNITIVE DAMAGES OF ANY KIND, OR FOR LOSS OF REVENUE OR PROFITS, LOSS OF BUSINESS, LOSS OF INFORMATION OR DATA, OR OTHER FINANCIAL LOSS ARISING OUT OF OR IN CONNECTION WITH THE SALE, INSTALLATION, MAINTENANCE, USE, PERFORMANCE, FAILURE, OR INTERRUPTION OF ITS PRODUCTS, EVEN IF POLYCOM OR ITS AUTHORIZED RESELLER HAS BEEN ADVISED OF THE POSSIBILITY OF SUCH DAMAGES, AND LIMITS ITS LIABILITY TO REPAIR, REPLACEMENT, OR REFUND OF THE PURCHASE

PRICE PAID, AT POLYCOM'S OPTION. THIS DISCLAIMER OF LIABILITY FOR DAMAGES WILL NOT BE AFFECTED IF ANY REMEDY PROVIDED HEREIN SHALL FAIL OF ITS ESSENTIAL PURPOSE.

DISCLAIMER. Some countries, states, or provinces do not allow the exclusion or limitation of implied warranties or the limitation of incidental or consequential damages for certain products supplied to consumers, or the limitation of liability for personal injury, so the above limitations and exclusions may be limited in their application to you. When the implied warranties are not allowed to be excluded in their entirety, they will be limited to the duration of the applicable written warranty. This warranty gives you specific legal rights which may vary depending on local law.

GOVERNING LAW. This Limited Warranty and Limitation of Liability shall be governed by the laws of the State of California, U.S.A., and by the laws of the United States, excluding their conflicts of laws principles. The United Nations Convention on Contracts for the International Sale of Goods is hereby excluded in its entirety from application to this Limited Warranty and Limitation of Liability.