



BETA USER GUIDE

1.0 | NOVEMBER 2018 | 3725-62048-001A

# Polycom Studio User Guide

Model: P009



Copyright© 2018, Polycom, Inc. All rights reserved. No part of this document may be reproduced, translated into another language or format, or transmitted in any form or by any means, electronic or mechanical, for any purpose, without the express written permission of Polycom, Inc.

6001 America Center Drive  
San Jose, CA 95002  
USA

**Trademarks** Polycom®, the Polycom logo and the names and marks associated with Polycom products are trademarks and/or service marks of Polycom, Inc. and are registered and/or common law marks in the United States and various other countries.



All other trademarks are property of their respective owners. No portion hereof may be reproduced or transmitted in any form or by any means, for any purpose other than the recipient's personal use, without the express written permission of Polycom.

**End User License Agreement** By installing, copying, or otherwise using this product, you acknowledge that you have read, understand and agree to be bound by the terms and conditions of the End User License Agreement for this product. The EULA for this product is available on the Polycom Support page for the product.

**Patent Information** The accompanying product may be protected by one or more U.S. and foreign patents and/or pending patent applications held by Polycom, Inc.

**Open Source Software Used in this Product** This product may contain open source software. You may receive the open source software from Polycom up to three (3) years after the distribution date of the applicable product or software at a charge not greater than the cost to Polycom of shipping or distributing the software to you. To receive software information, as well as the open source software code used in this product, contact Polycom by email at [OpenSourceVideo@polycom.com](mailto:OpenSourceVideo@polycom.com) (for video products) or [OpenSourceVoice@polycom.com](mailto:OpenSourceVoice@polycom.com) (for voice products).

**Disclaimer** While Polycom uses reasonable efforts to include accurate and up-to-date information in this document, Polycom makes no warranties or representations as to its accuracy. Polycom assumes no liability or responsibility for any typographical or other errors or omissions in the content of this document.

**Limitation of Liability** Polycom and/or its respective suppliers make no representations about the suitability of the information contained in this document for any purpose. Information is provided "as is" without warranty of any kind and is subject to change without notice. The entire risk arising out of its use remains with the recipient. In no event shall Polycom and/or its respective suppliers be liable for any direct, consequential, incidental, special, punitive or other damages whatsoever (including without limitation, damages for loss of business profits, business interruption, or loss of business information), even if Polycom has been advised of the possibility of such damages.

**Customer Feedback** We are striving to improve our documentation quality and we appreciate your feedback. Email your opinions and comments to [DocumentationFeedback@polycom.com](mailto:DocumentationFeedback@polycom.com).

**Polycom Support** Visit the [Polycom Support Center](#) for End User License Agreements, software downloads, product documents, product licenses, troubleshooting tips, service requests, and more.

# Contents

---

<b>Before You Begin</b> .....	<b>2</b>
Audience, Purpose, and Required Skills.....	2
Related Documentation.....	2
Resources and Feedback.....	2
<b>Getting Started</b> .....	<b>4</b>
Polycom Studio Overview.....	4
Polycom Companion Application Features.....	4
Powering On and Off.....	5
Navigating Polycom Studio.....	5
Basic Polycom Studio LED Indicators.....	7
Polycom Studio Remote Control.....	8
Polycom Studio Privacy Shutter.....	9
Accessibility Features.....	11
<b>Using Polycom Studio</b> .....	<b>12</b>
Set Polycom Studio as the Default Audio and Video Device.....	12
Using Camera Presets.....	12
Save Camera Presets.....	12
Call Camera Presets.....	13
Connect Polycom Studio to a Bluetooth Device.....	13
<b>Troubleshooting</b> .....	<b>14</b>
Identifying Issues Using the LED Indicators.....	14
Restore Default Settings.....	14
Reset Polycom Studio to Factory Settings.....	15
Pair the Bluetooth Remote Control with Polycom Studio.....	15

# Before You Begin

---

## Topics:

- [Audience, Purpose, and Required Skills](#)
- [Related Documentation](#)
- [Resources and Feedback](#)

This chapter introduces overview information and references about Polycom Studio USB video bar, an all-in-one audio-video hub.

## Audience, Purpose, and Required Skills

This guide is intended for beginning users, as well as intermediate and advanced users, who want to learn more about the features available with Polycom Studio.

## Related Documentation

You can find all Polycom Studio documentation on the **Documents & Software** page at Polycom Support.

The available guides on [Polycom Support](#) are:

- Polycom Studio User Guide
- Polycom Studio Setup Sheet
- Polycom Studio Release Notes
- Polycom Studio Regulatory Notices
- Polycom Studio Port Usage Guide
- Polycom Studio Encryption Data Guide
- Polycom Studio Quick Tips
- Polycom Studio Offer of Source for Open Source Software

## Resources and Feedback

For support and to report findings, register with the Polycom Beta Tester Community to access Polycom support resources.

### Resources and Feedback

---

Beta hardware and software support

To ask support questions and to report hardware or software defects, please use the contact information you received when you joined the beta program.

---

Beta software, documentation, and feedback

Refer to the [Polycom Beta Tester Community](#) to access beta software and documentation. You can enter all feedback and support requests through this site.

---

Polycom Support

Use only the contact information provided by the Beta Support Team available through [betasupport@polycom.com](mailto:betasupport@polycom.com). Neither Polycom nor reseller support channels can provide service support for this beta release.

---

# Getting Started

---

## Topics:

- [Polycom Studio Overview](#)
- [Powering On and Off](#)
- [Navigating Polycom Studio](#)
- [Accessibility Features](#)

The Polycom Studio USB video bar is an all-in-one video and audio hub for small rooms.

## Polycom Studio Overview

The Polycom Studio USB video bar is a high-quality camera and speakerphone system that integrates an auto-framing camera, stereo microphones, and stereo speakers.

Polycom Studio works with applications that support standard USB peripherals, such as Polycom RealPresence Desktop, Microsoft Skype for Business, Microsoft Teams, Zoom, and BlueJeans. As a USB camera and speakerphone, you can use the Polycom Studio USB video bar for audio or video conferencing and as a speaker for your local devices.

You can also use Polycom Studio as a Bluetooth device that supports audio calls and streaming music playback from a mobile device.

You can connect the Polycom Studio USB video bar to either a permanently installed PC USB host in the room or to a laptop that you bring to the room. In all configurations, you primarily connect through USB, with an optional Bluetooth connection.

If you're the administrator of the Polycom Studio USB video bar, download Polycom Companion for advanced setup options, such as connecting Polycom Studio to your Wi-Fi. You can manage the Polycom Studio USB video bar from Polycom Device Management Services for Enterprises or Polycom RealPresence Resource Manager in a Wi-Fi environment. See the [Polycom Documentation Library](#) for more information about these products.

Highlights of the Polycom Studio USB video bar include the following:

- High-fidelity stereo microphones that pick up sound within 3.66 m (12 ft), together with spatial audio to imitate life-like presence and clarity. Polycom Studio also supports Polycom Acoustic Fence with Beam Shaping that enables video conferencing in open workspaces by capturing only the voices within a defined zone.
- Ultra-wide 120-degree field of view that captures 4K UHD video.
- Automatic speaker-tracking technology that zooms in on the person who's talking without using a remote control or camera presets. When there's no active speaker, the group frame function automatically frames all conference participants as a group.

## Polycom Companion Application Features

The Polycom Companion application provides advanced configuration of the Polycom Studio USB video bar.

You can configure the following settings on the Polycom Companion application:

- Audio and video configurations
- Wi-Fi and Bluetooth configurations
- Provisioning configuration
- Software upgrade
- Log download
- Camera control

## **Powering On and Off**

The Polycom Studio USB video bar doesn't have a power button. When you plug in the power cord, the device turns on.

Polycom Studio is eco-friendly and consumes very little power when it's not working.

## **Navigating Polycom Studio**

The Polycom Studio USB video bar includes an integrated device with a camera, speakers, a microphone array, and a remote control.

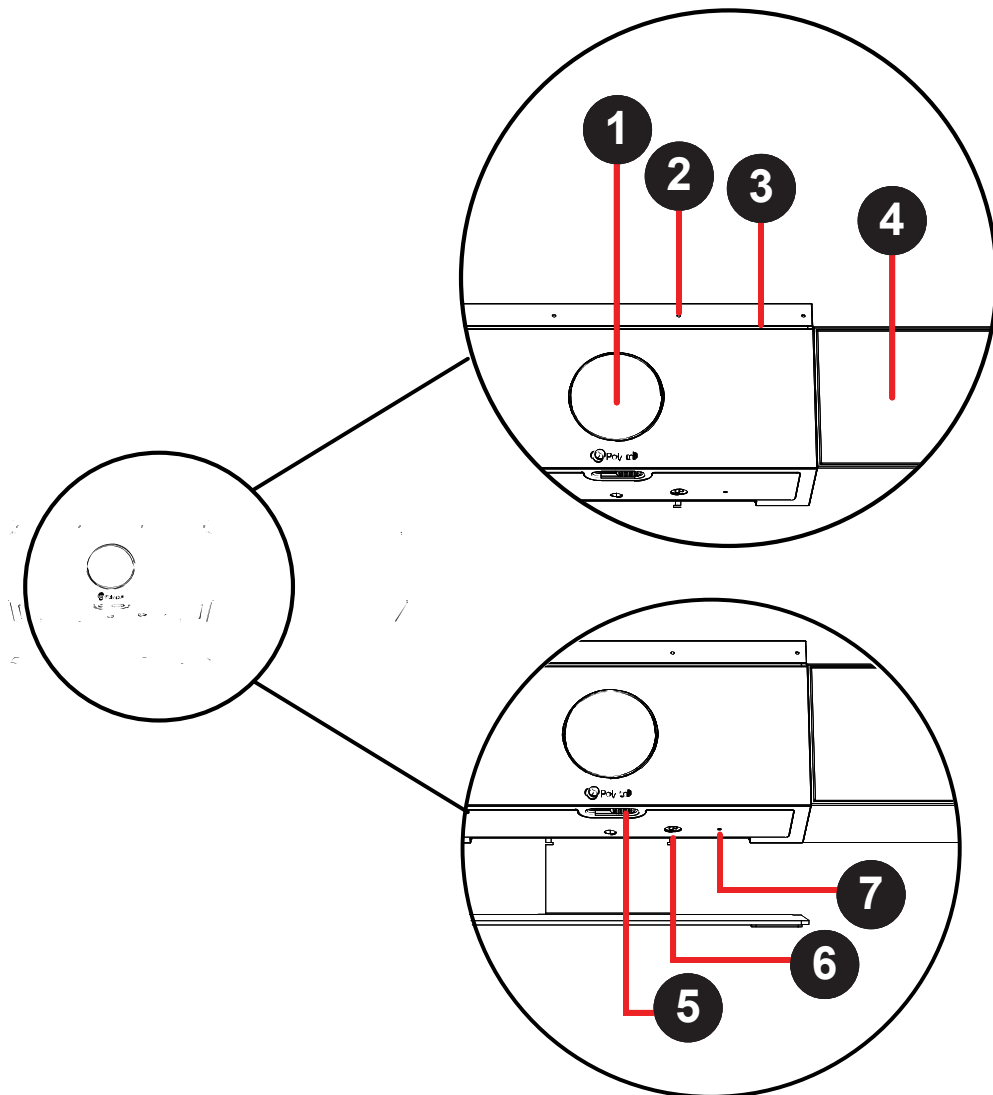



### Polycom Studio Feature Descriptions

Reference	Feature	Feature Description
1	Camera	Camera with a privacy shutter that enables or disables the video input as you choose
2	LED light indicators	Indicate the status and the tracked speaker
3	Microphone array	Stereo microphone that captures and transmits audio
4	Speakers	Stereo audio output
5	Privacy shutter lever	Covers or uncovers the camera lens
6	Remote control pairing	Enables the Bluetooth remote control pairing mode
7	Reset	Resets the Polycom Studio USB video bar to the factory software version or clears all saved configurations

## Basic Polycom Studio LED Indicators

The Polycom Studio USB video bar provides an LED light bar above the camera to help you understand the system's behaviors.

### Basic Polycom Studio LED Indicators and Status

Indicator	Position	Status
Chasing white	All while alternating	Camera boot initialization in progress
Blinking blue	Two in the middle	Bluetooth discovery
Solid blue for three seconds	Two in the middle	Bluetooth paired
Solid amber	Two in the middle	Standing by The privacy cover is open, and the camera is in sleep mode with no active video output.
Blinking green or white	All	Incoming call
Solid green or amber	Two in the middle	Outgoing call

Indicator	Position	Status
Solid green or white	One or two (when in the middle), indicating the tracked speaker or the direction of the camera	Working  The lights are green with supported applications, with the following cases: <ul style="list-style-type: none"> <li>Tracking people in the group framing and speaker-tracking mode.</li> <li>Indicating the direction of the camera that you customize in the pan-tilt-zoom (PTZ) mode.</li> </ul>
Solid white for three seconds	Two in the middle	Saving a preset
Solid red	All	Muted microphone

## Polycom Studio Remote Control

The Polycom Studio USB video bar provides a Bluetooth remote control, which Polycom pre-pairs with the USB video bar so you can use it out-of-the-box.

By default, Polycom Studio enables the Automatic Group Framing and Speaker-Tracking function, which provides hands-free experience except for basic buttons like volume, mute, answer, and hang-up.

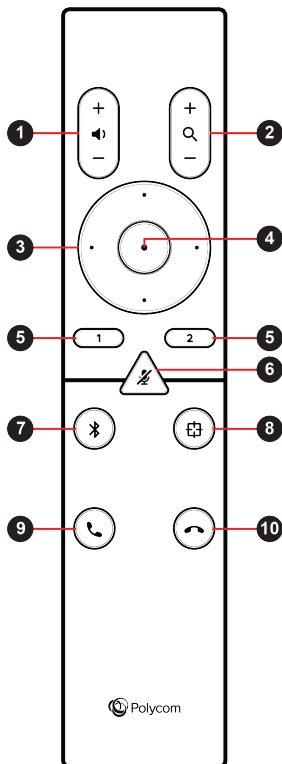

Button Icon	Button Name	Description
1	Volume Up/Down	Adjust speaker volume
2	Zoom In/Out	Adjust camera zoom in/out when the group framing and speaker-tracking mode is off
3	Camera Directions	Adjust the direction of camera when the group framing and speaker-tracking mode is off
4	Home	Resets the camera to its original status when the group framing and speaker-tracking mode is off
5	Preset 1/2	<ul style="list-style-type: none"> <li>▪ Long press to store a camera setting</li> <li>▪ Short press to load a camera setting</li> </ul> <p>The preset buttons only work when the group framing and speaker-tracking mode is off.</p>
6	Mute/Unmute	<p>Mutes or unmutes the microphone</p> <p>Long press the button to set the remote control ready for pairing.</p>
7	Bluetooth	Long press to enable other Bluetooth devices to find the Polycom Studio USB video bar
8	Speaker-Tracking with Group Framing	Enables or disables the group framing and speaker-tracking mode
9	Answer	Answers an incoming call
10	Hang Up	Hangs up a call

## Polycom Studio Privacy Shutter

The Polycom Studio USB video bar provides a physical cover on the camera lens to protect your privacy. When you slide the shutter lever to the left, the shutter opens and the camera captures the room.

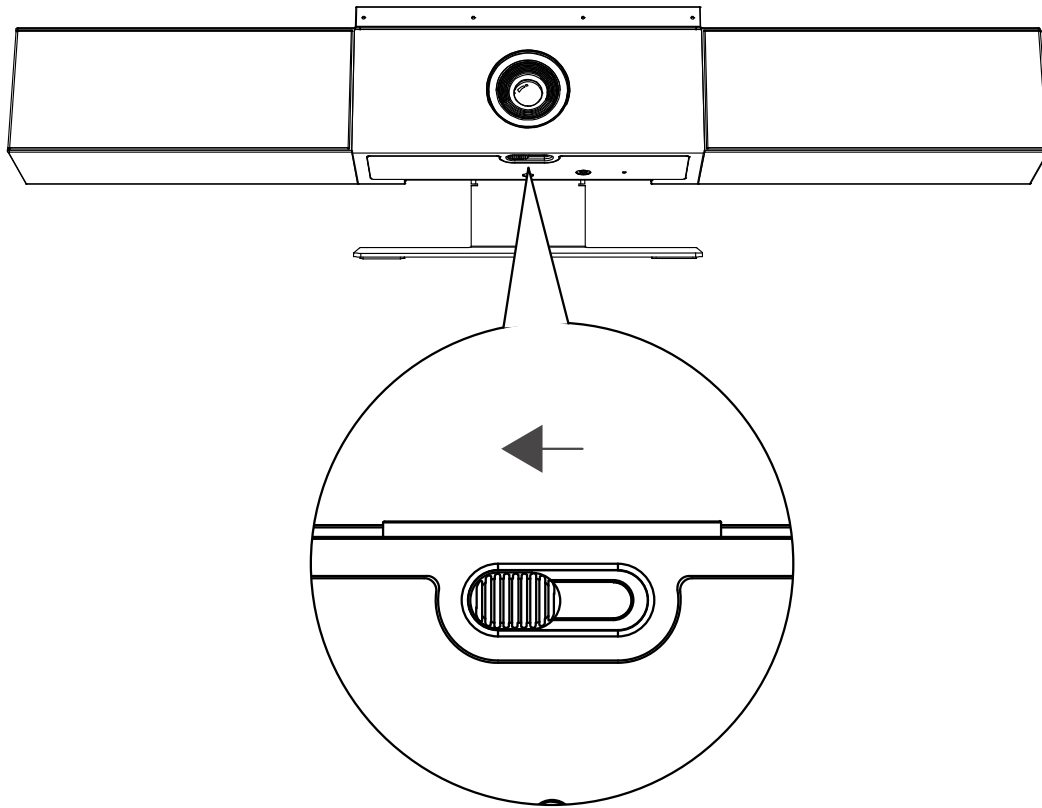

When you slide the lever to the right, the shutter closes and the camera turns off.

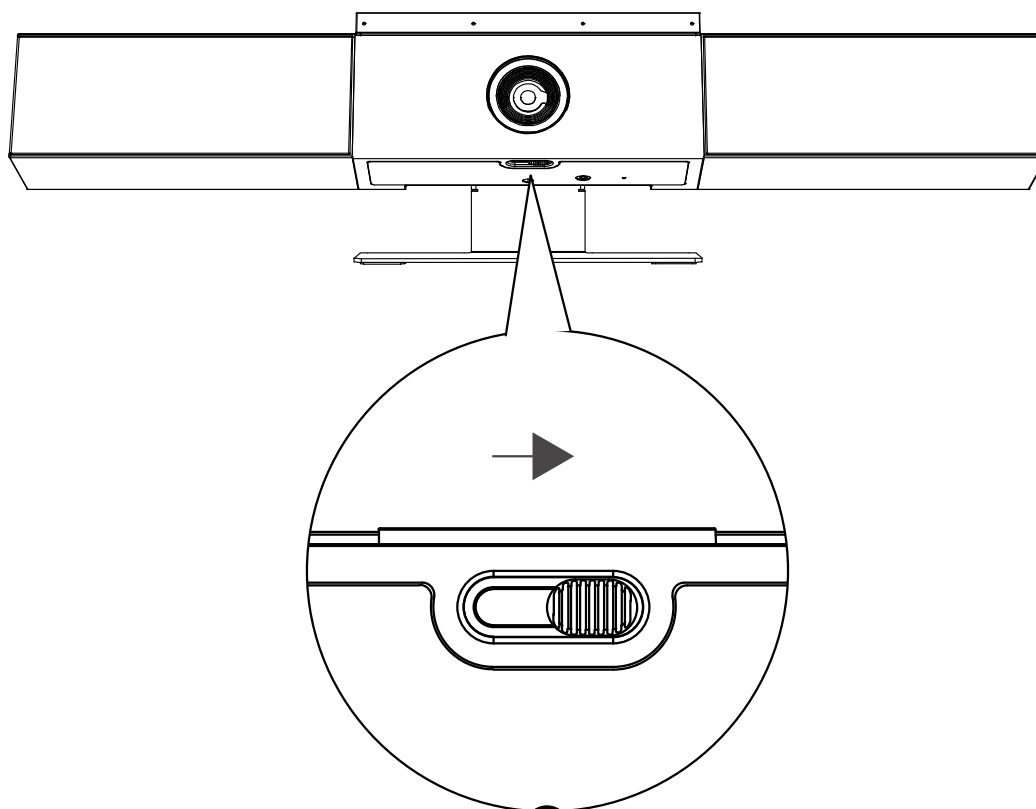

If you close the camera privacy shutter during a call, the camera status changes from working to standing by, and the LED lights turn to solid amber.

## Accessibility Features

The Polycom Studio USB video bar includes a number of features to accommodate hearing, vision, or mobility-impaired users.

Accessibility Feature	Description
Visual and audio notifications	LED indicators let you know when status changes, functions work, and whether features are enabled. In most cases an audio tone accompanies the LED changes.
Tactile buttons	The mechanical buttons on the remote control and on the device with visual contrast.
Adjustable volume	You can raise or lower the volume using the remote control.
Built-in speaker and microphone	Polycom Studio has speaker and microphone that allow you to hear audio and speak without having to use headset.

# Using Polycom Studio

---

## Topics:

- [Set Polycom Studio as the Default Audio and Video Device](#)
- [Using Camera Presets](#)
- [Connect Polycom Studio to a Bluetooth Device](#)

Once you plug in the power cable, you can start using the Polycom Studio USB video bar.

Connect the Polycom Studio USB video bar to your laptop or computer with the USB cable. Additionally, you can also connect it to your Bluetooth host devices.

## Set Polycom Studio as the Default Audio and Video Device

If you use the Polycom Studio USB video bar together with a supported application for video calls, you may need to set Polycom Studio as the default audio and video device of your application.

The following is a general procedure that you can refer to. Your application may use different terms or categories.

### Procedure

1. Go to your software client **Settings**.
2. Find **Audio Device** and **Video Device**.
3. Select **Polycom Studio** as the device and click **Save**.

## Using Camera Presets

You can save two settings for Pan, Tilt, Zoom, and Focus for the Polycom Studio camera.

If you always use Polycom Studio in the same room, you may want to use the preset buttons on the remote control.

### Save Camera Presets

The two number buttons on the Polycom Studio remote control serve as preset shortcuts.

Turn off the group framing and speaker-tracking mode before you save a preset.

### Procedure

1. Adjust the camera.
2. Long press the **1** or **2** button on the remote control.  
The middle LED lights stay white for three seconds with a notification sound.

---

**Note:** If the button already has a saved setting, your new setting overwrites it.

---

## Call Camera Presets

If your camera doesn't track the speaker, you can use the preset buttons on the remote control to adjust the camera angle.

### Procedure

1. Turn off the group framing and speaker-tracking mode.
2. Press the **1** or **2** button on the remote control to restore the corresponding saved angle.

## Connect Polycom Studio to a Bluetooth Device

Connect the Polycom Studio USB video bar to a Bluetooth device and use it as the speaker and microphone of the device.

You can pair the Polycom Studio USB video bar with a mobile phone, a computer or laptop, or a tablet.

### Procedure

1. On the remote control, long press **Bluetooth**  to enable the pairing mode.  
The LED lights blink blue in the middle during the pairing process.
2. On your device, enable Bluetooth and select **Polycom Studio** from the list of available devices.  
The middle LED lights keep solid blue for three seconds with a notification sound.

You can start playing music or make phone calls from the Polycom Studio USB video bar speakerphone once you connect.

# Troubleshooting

---

## Topics:

- [Identifying Issues Using the LED Indicators](#)
- [Restore Default Settings](#)
- [Reset Polycom Studio to Factory Settings](#)
- [Pair the Bluetooth Remote Control with Polycom Studio](#)

If you experience issues with your Polycom Studio USB video bar, try the following solutions to resolve certain issues.

## Identifying Issues Using the LED Indicators

The LED light indicators provide troubleshooting information for your Polycom Studio USB video bar.

### Polycom Studio LED Troubleshooting Indicators and Status

Indicator	Position	Status
Blinking faint red	All	Error preventing normal operation.
Pulsing faint amber	All	Device firmware update in progress.

## Restore Default Settings

You can erase all configuration and restore the Polycom Studio USB video bar default settings.

Use the Polycom Companion application to configure some of the settings. The default settings to be cleared include but are not limited to:

- Password
- Remote control presets
- Wi-Fi settings
- Camera settings
- Audio settings
- Bluetooth settings
- System information (such as system name)
- Logs

The current version of software remain the same after restoring.



**Procedure**

1. Turn on the Polycom Studio USB video bar and press the **Reset** button on the bottom of the USB video bar for 10 seconds.

The LED lights start out chasing white, then turn to solid amber.

The Polycom Studio USB video bar clears all saved settings and logs and reboots.

Restoring the defaults unpairs the remote control. Re-pair the remote control after the Polycom Studio USB video bar reboots.

## Reset Polycom Studio to Factory Settings

You can reset the Polycom Studio USB video bar to factory settings if persistent issues remain after troubleshooting.

Resetting the USB video bar to factory settings unpairs the remote control. You must re-pair the remote control with the Polycom Studio USB video bar after you reset the system.

**Procedure**

1. Unplug the Polycom Studio USB video bar to turn it off.
2. Find the reset pinhole on the bottom of the USB video bar.
3. Use a pin or paperclip to press and hold the reset button and plug in the USB video bar at the same time to turn it on.

The Polycom Studio USB video bar reboots with pulsing amber LED lights.

The Polycom Studio USB video bar rolls back to the factory software version and loses all configuration and logs.

## Pair the Bluetooth Remote Control with Polycom Studio

If you reset or restore your Polycom Studio USB video bar or replace the remote control, you must pair the remote control to the USB video bar.

The process may take several tries if you don't get the corresponding LEDs of each step.

**Procedure**

1. Optional: If you want to replace an old remote control, remove the battery to disable it.
2. Press and hold the **Connect** button on the bottom of the USB video bar until the LEDs blink blue in the middle with a notification sound.

The LED lights blink blue in the middle during the pairing process.

3. Long press **Mute**  on the remote control.

The middle LED lights keep solid blue for three seconds with a notification sound.