

DECT application module

Model no.: KT4586

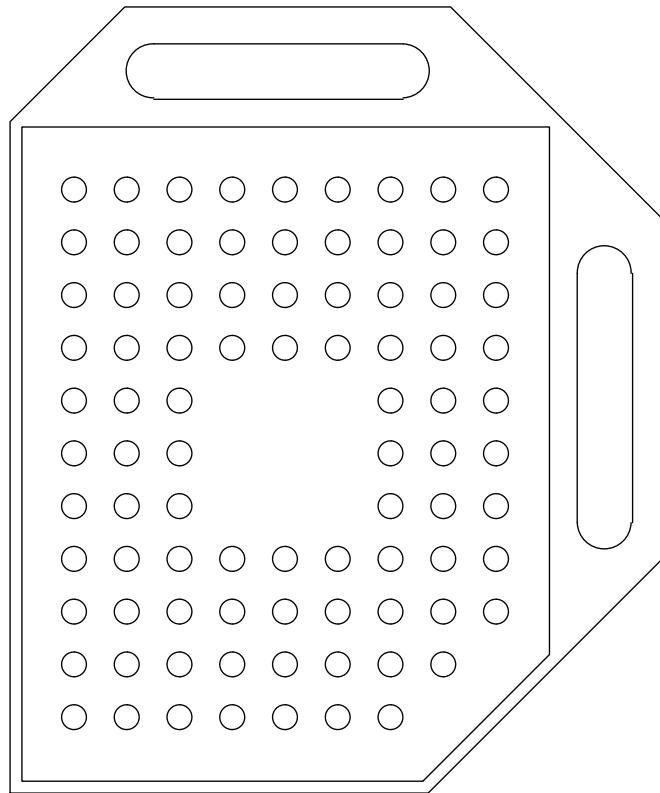

PRODUCT SPECIFICATION

1.	<i>Preface</i>	3
2.	<i>Features</i>	3
3.	<i>Circuit description</i>	4
4.	<i>Pin configuration</i>	5
5.	<i>Mechanical dimension</i>	7
6.	<i>PCB integration & soldering</i>	8
7.	<i>FCC compliance statement</i>	11
8.	<i>Safety compliance statement</i>	12

Proprietary and Confidential

The information contained herein is the sole intellectual property of Polycom, Inc. No distribution, reproduction or unauthorized use of these materials is permitted without the expressed written consent of Polycom, Inc. Information contained herein is subject to change without notice and does not represent commitment of any type on the part of Polycom, Inc. Polycom and Accord are registered trademarks of Polycom, Inc.

Notice

While reasonable effort was made to ensure that the information in this document was complete and accurate at the time of printing, Polycom, Inc., cannot assume responsibility for any errors. Changes and/or corrections to the information contained in this document may be incorporated into future issues.

POLYCOM	ED	2.0	DATE	29-06-2011	SIGN	HBR	Page 2 of 12
	Model no.: KT4586			141993XX-DS			

1. Preface

The KT4586, DECT application module is used to transfer messaging, data, and voice signals by use of the radio frequency spectrum according to the DECT standard.

KT4586 is a fully approved module that complies with the following standards and certifications:

EN 301 406 V2.1.1:2009-07 (DECT radio)

EN 300 175-1 to 8 (DECT CI)

EN 301 489-1 V1.8.1:2008-04, EN 301 489-6 V1.3.1:2008-08 (EMC)

IEC 60950-1:2005 (ed. 2.0) +am1:2009, EN 60950-1:2006+A11:2009+A1:2010 (Safety)

R&TTE certificate

FCC PART 15, Subpart D

FCC part 15B

FCC SAR

RSS-213

This means that by integration on a main board no radio test is required.

2. Features

RF range:	1880 – 1930 MHz
DECT channels:	60(EU) 30(US) logical duplex channels.
Receiver sensitivity:	Typ. < -93 dBm [BER,1000 ppm].
Transmit power (NTP):	Typ. 23 dBm. , 20.2 dBm (US)
Power supply range:	2.0 – 3.45V
Current consumption:	TBD
Temp. Range:	-20°C to +60°C.
Size:	25.0 X 30.0 X 3.0mm.
Other features:	See data sheet for SC14441

3. Circuit description

The module consists mainly of the fully integrated CMOS transceiver and baseband processor SC14441 from SiTel semiconductor intended for DECT 6.0 handsets and base stations. RF switches and other components are added to the design in order to perform the desired functionality required for DECT/GAP. Figure 1 shows the block diagram of the module.

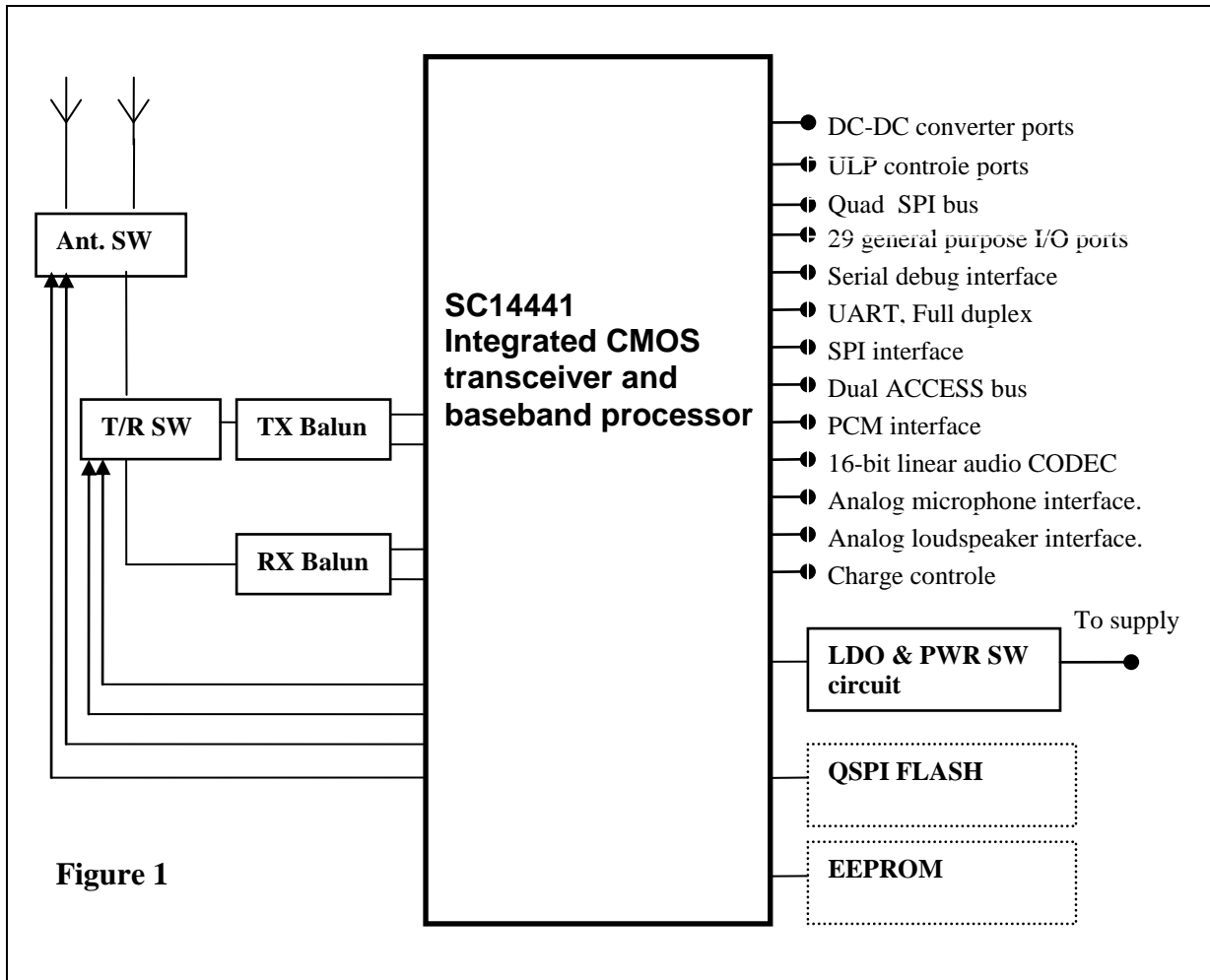

Figure 1

The DECT transceiver/baseband SC14441

SC14441 is a 1.8V single chip for DECT applications containing a fully integrated radio transceiver and baseband processor. It is designed to perform the complete transmit and receiver function. The device is designed to operate the frequency synthesizer in a close loop configuration both during transmit and receive mode. Logic output ports are used to control the T/R switch and antenna switch for FAD (Fast Antenna Diversity).

The CompactRISC CR 16Cplus microprocessor with a single wire debug port running from ROM controls the protocol stack and the I/O peripherals, keyboard, UART, ACCESS bus, SPI, LED drivers and RF switches.

The audio path comprises a 16 bit CODEC with an analog frontend including a high efficiency 4 ohm audio amplifier (class D) and a programmable Gen2DSP supporting various telecommunication algorithms. Detailed information about the chip is available from SiTel semiconductor.

4. Pin configuration

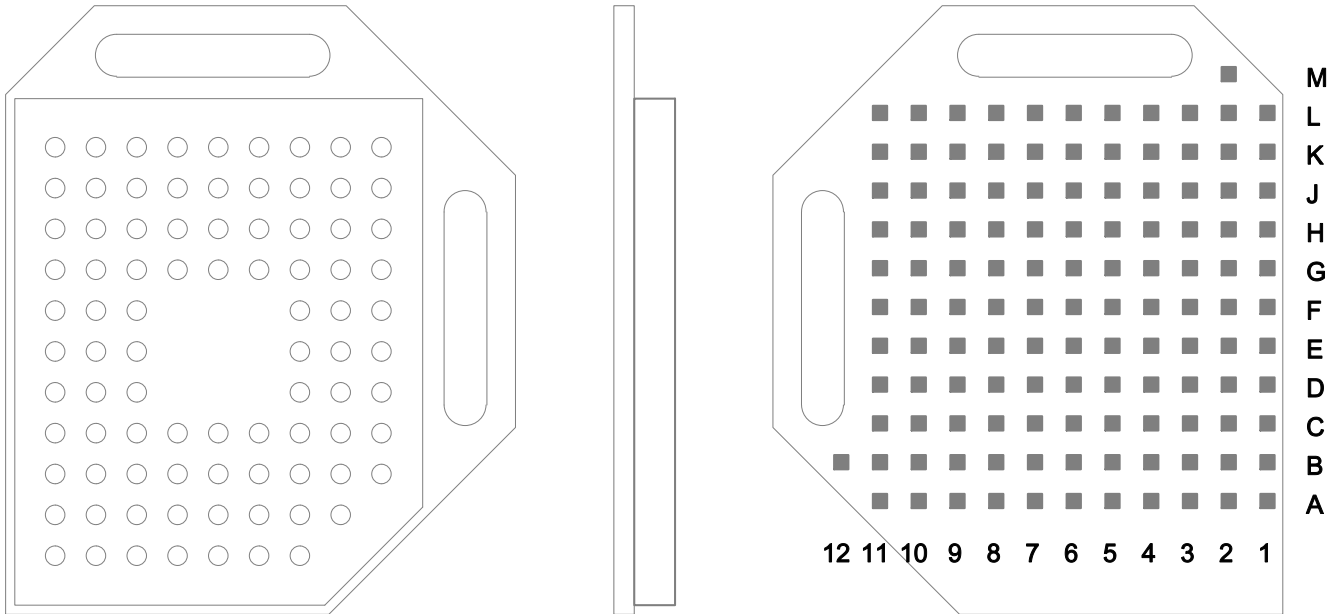

A1	GND	B1	GND	C1	GND	D1	GND	E1	VDDPA	F1	SOCp
A2	GND	B2	GND	C2	P30	D2	P31	E2	GND	F2	P10
A3	GND	B3	CP_VOUT1	C3	GND	D3	P16	E3	CHARGE_CTRL	F3	ADC2
A4	CP_VOUT2	B4	P15	C4	P27	D4	P17	E4	SOCn	F4	DC_CTRLN
A5	VDDIO	B5	GND	C5	P14	D5	GND	E5	GND	F5	ULP_PORT
A6	P12	B6	P26	C6	P11	D6	GND	E6	GND	F6	ULP_VBAT
A7	GND	B7	P05	C7	GND	D7	GND	E7	GND	F7	ULP_MAIN_CTRL
A8	GND	B8	GND	C8	P00	D8	GND	E8	GND	F8	RFP0n
A9	VBAT	B9	P01	C9	GND	D9	P24	E9	GND	F9	P23
A10	P04	B10	VBATT	C10	JTAG	D10	VDD	E10	P07	F10	P13
A11	RSTn	B11	GND	C11	VCCRF	D11	P25	E11	GND	F11	P06
		B12	TP2								
G1	GND	H1	VREFm	J1	GND	K1	VREFp	L1	GND		
G2	LSRn	H2	LSRp	J2	MICH	K2	MICp	L2	MICn	M2	TP1
G3	GND	H3	P37	J3	GND	K3	P32_CIDINp	L3	GND		
G4	P33	H4	ONE_CELL	J4	P35	K4	P36	L4	GND		
G5	GND	H5	DC_SENCE	J5	GND	K5	P34	L5	RFP0		
G6	DC_CTRL	H6	DC_I	J6	RFP1	K6	WLED0	L6	GND		
G7	GND	H7	P22	J7	GND	K7	WLED1	L7	GND		
G8	LDORF_CTRL	H8	RFP2	J8	P21	K8	P20	L8	WLED2		
G9	GND	H9	GND	J9	GND	K9	GND	L9	GND		
G10	GND	H10	GND	J10	GND	K10	RF0	L10	RF1		
G11	GND	H11	GND	J11	GND	K11	RF2	L11	GND		

Leave K10, K11, L10, M2 and B12 (RF ports and test pin's) unconnected to the main board without any conducting plan underneath. Connect VREFm to local GND on the main board.

Top view of the pin's

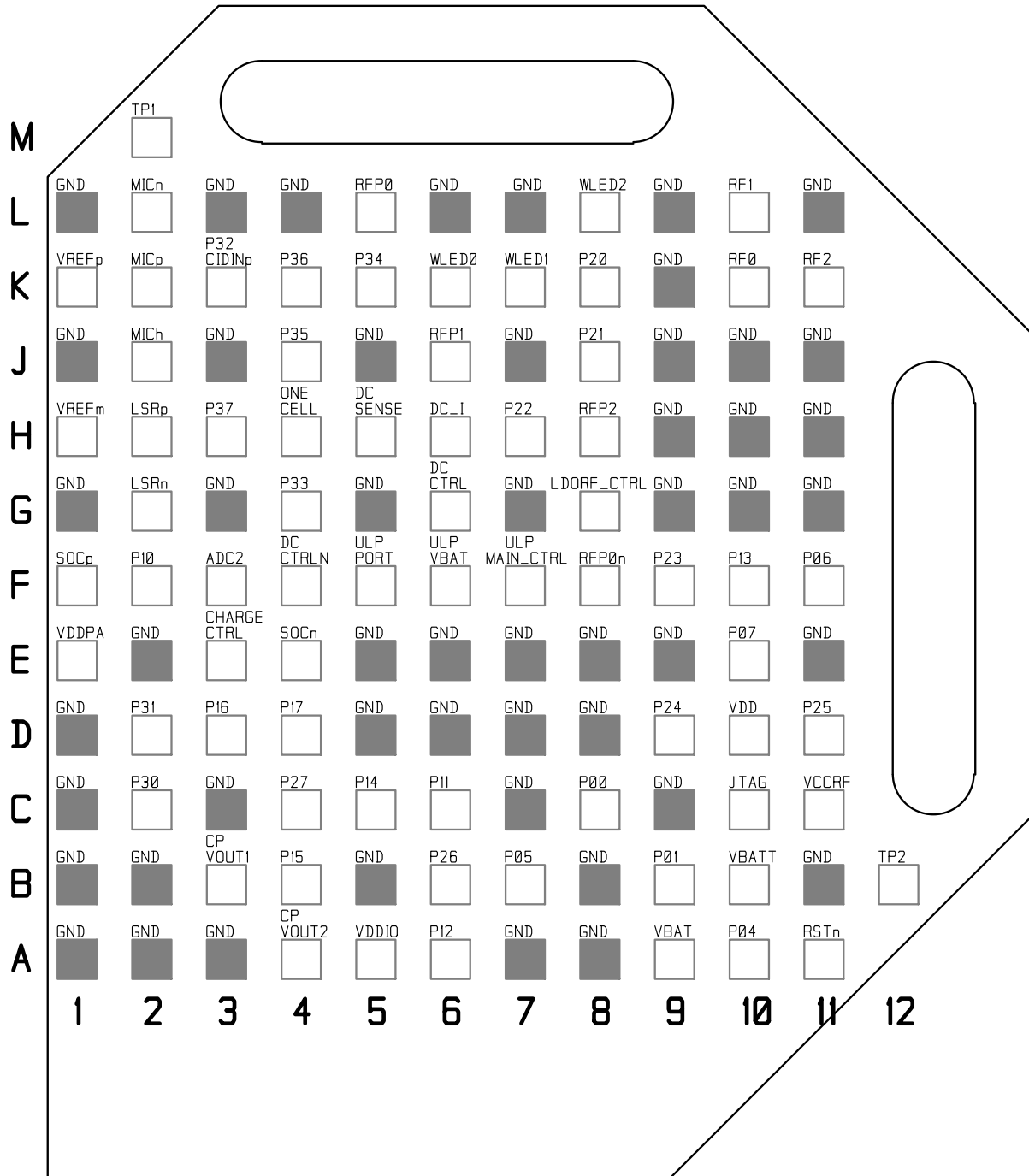

5. Mechanical dimension

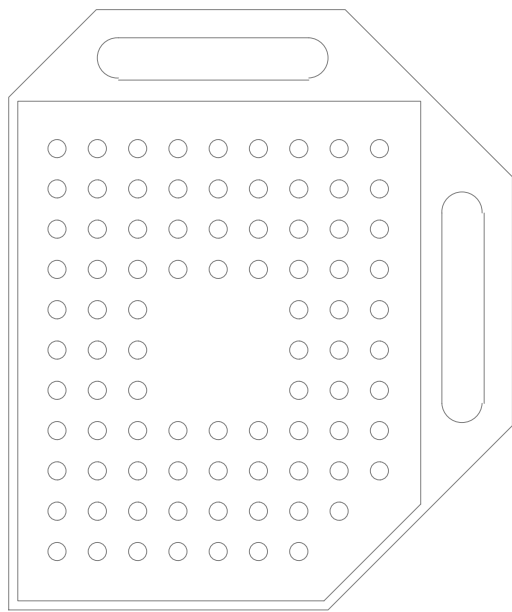
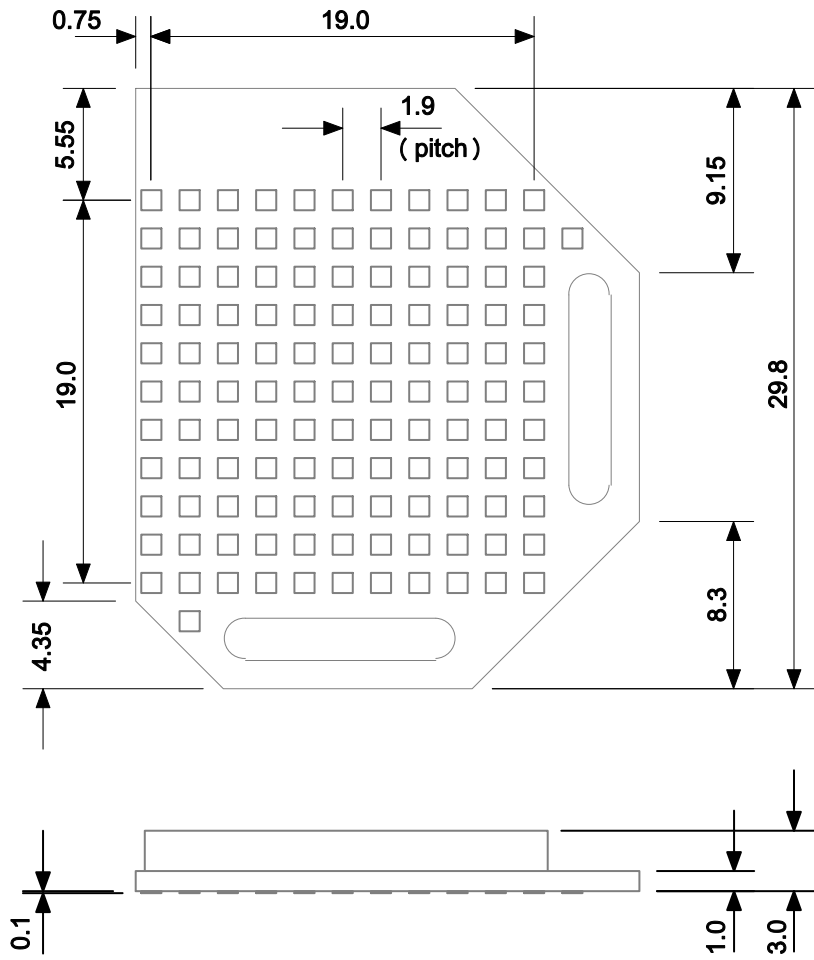

6. PCB integration & soldering

Recommended integration on the main PCB

In order to ensure proper coverage and to avoid detuning of the antennas, it is very important to place the module in a free proper way on the main board and in relation to other surrounding materials. As a “thumb rule”, keep a distance of at least 10 mm from the antenna element to conducting objects and at least 5 mm to non-conducting objects - depending of the size. Keep in mind that electrical shielding objects, even partly surrounding the antennas, will normally cause a significant degradation of the coverage. Place the module at the corner of the main-board as shown below. If the module has to be placed away from the edge of the main-board, then avoid conducting areas in front of the antennas and make a cut-out in the main board underneath the antennas as shown below. Keep solid ground on layer 2 out to the edges of the main board as shown.

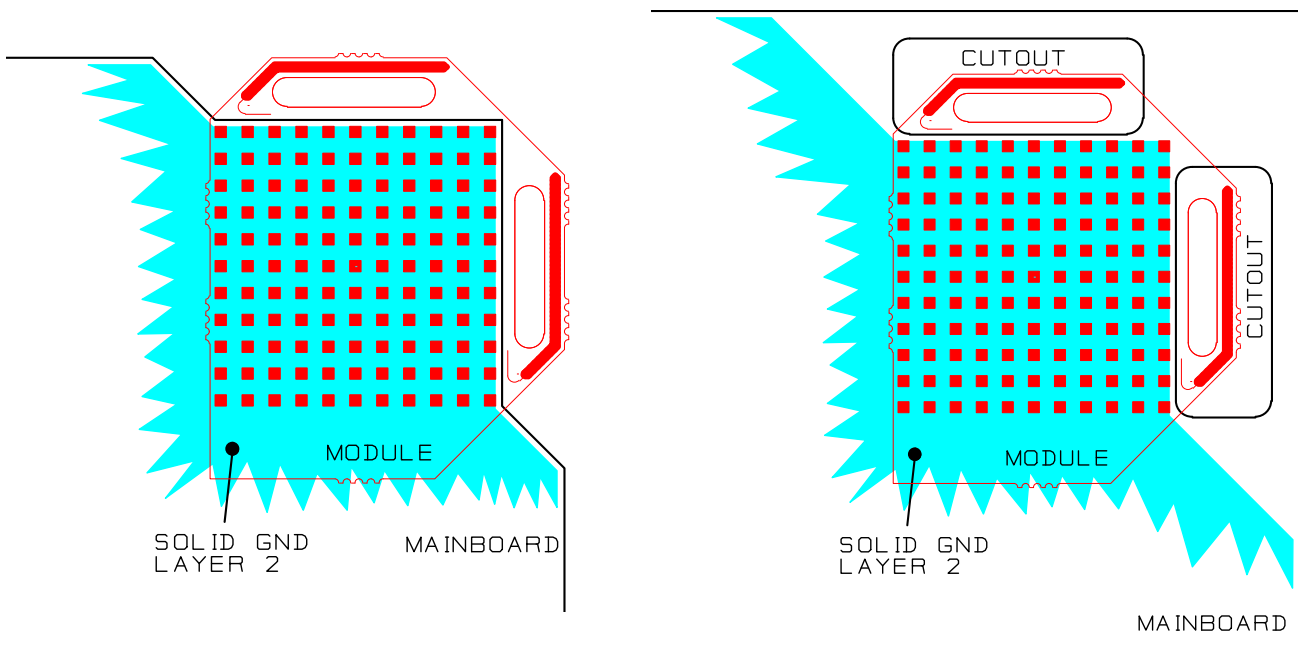
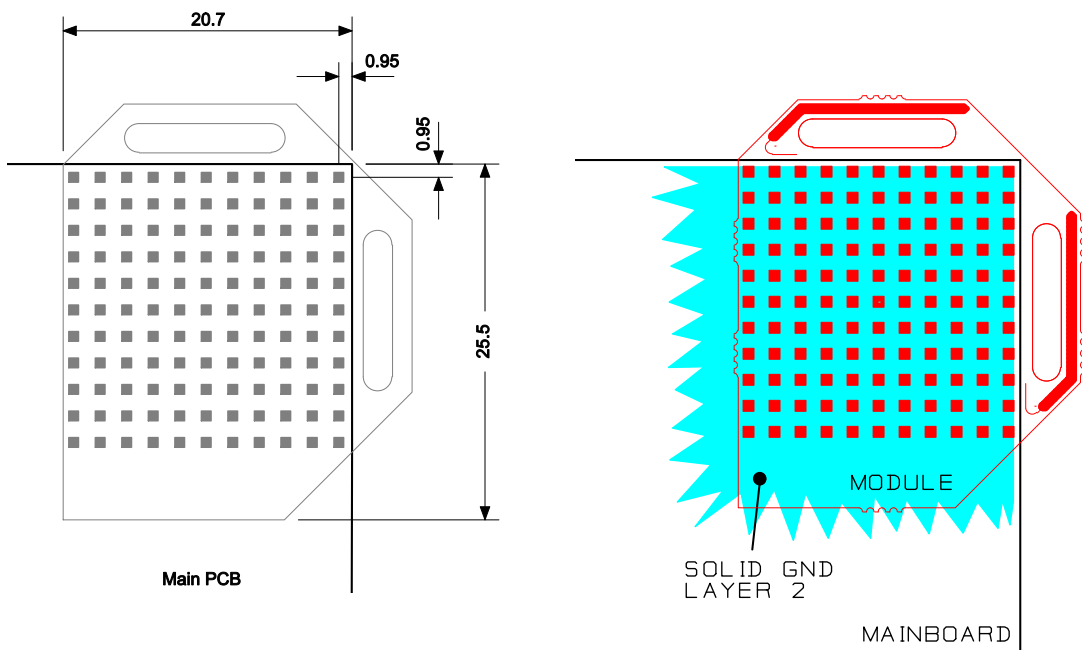

Recommended copper pad and solder mask opening (NSMD)

Solder mask opening 1,00x1,00mm

Cu. pad 0,80x0,80mm

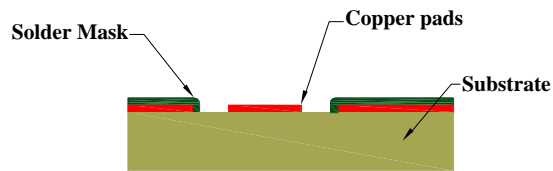
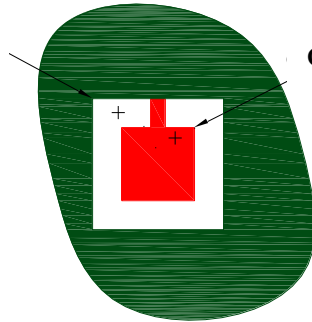

Recommended stencil design

(stencil thickness 0.122 mm)

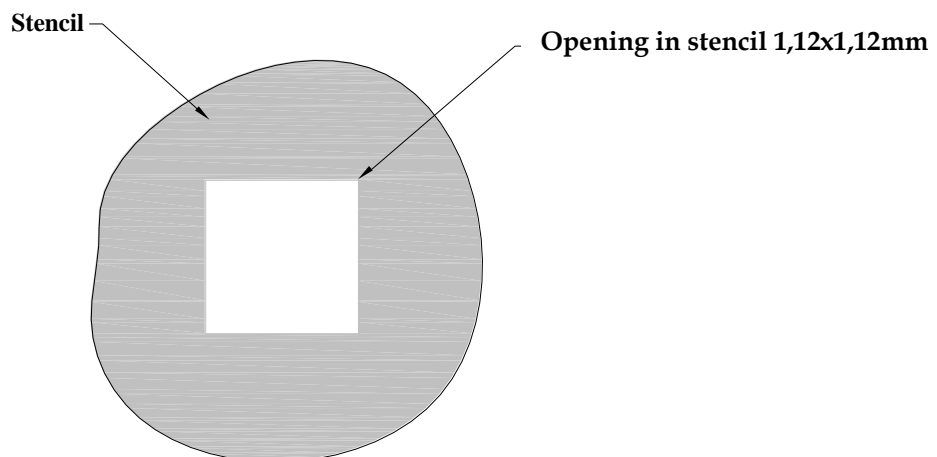

Recommended re-flow profile

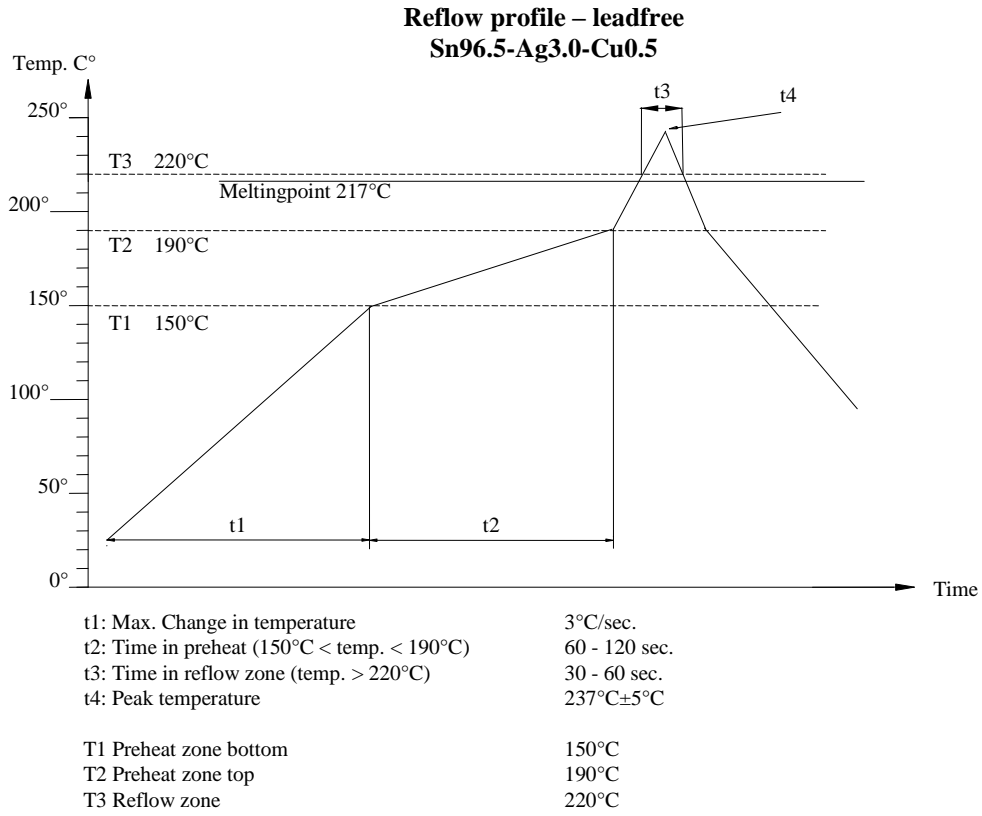

We recommend to fabricate PCB in accordance with IPC-A-600G, IPC-6012B, IPC-6016/A and IPC-6018A, Class 2; per IPC-6011 using customer supplied data files.

7. FCC compliance statement

This device complies with Part 15 of the FCC Rules

Operation is subject to the following two conditions:

(1) this device may not cause interference, and (2) this device must accept any interference, including interference that may cause undesired operation of the device.

Information to User:

This equipment has been tested and found to comply with the limits for a Class B digital device, pursuant to Part 15 of the FCC Rules. These limits are designed to provide reasonable protection against harmful interference in a residential installation. This equipment generates, uses and can radiate radio frequency energy and, if not installed and used in accordance with the instructions, may cause harmful interference to radio communications. However, there is no guarantee that interference will not occur in a particular installation. If this equipment does cause harmful interference to radio or television reception, which can be determined by turning the equipment off and on, the user is encouraged to try to correct the interference by one or more of the following measures:

- Reorient or relocate the receiving antenna
- Increase the separation between the equipment and receiver
- Connect the equipment into an outlet on a circuit different from that to which the receiver is connected.
- Consult the dealer or an experienced radio/TV technician for help.

FCC / IC Canada Labeling of host device:

The modular transmitter is labeled with its own FCC and IC identification number, and, if the FCC or IC identification numbers are not visible when the module is installed inside another device, then the outside of the device into which the module is installed must also display a label referring to the enclosed module. This exterior label shall use wording as the following: "Contains FCC ID: M72-PK4586 and Contains IC: 1849C-PK4586".

RF Exposure information:

The internal antennas used for this mobile transmitter must provide a separation distance of at least 20 cm from all persons. OEM integrators and end users must be provided with transmitter operating conditions for satisfying RF exposure compliance.

Antenna information:

The module has been tested and approved for use with the antenna listed below:

Type of antennas: PCB monopole antenna.
Gain of the antennas: 1.2 dBi
Frequency range: 1920-1930 MHz

The use of that module in combination with a not listed antenna must be authorized with respective regulatory agencies.

POLYCOM	ED	2.0	DATE	29-06-2011	SIGN	HBR	Page 11 of 12
	Model no.: KT4586				141993XX-DS		

8. Safety compliance statement

- 1) The specific external power supply for the DECT application module KT4585A has to fulfil the requirements according to clause 2.5 (Limited power source) of this standard EN 60950-1:2006.
- 2) Interconnection circuits shall be selected to provide continued conformance to the requirements of clause 2.2 for SELV (Safety Extra Low Voltage) circuits according to EN 60950-1:2006 after making connections.
- 3) Interface type not subjected to over voltages (i.e. does not leave the building).
- 4) Requirements additional to those specified in this standard may be necessary for:
 - Equipment intended for operation in special environments (for example, extremes of temperature, excessive dust, moisture or vibration, flammable gases and corrosive or explosive atmospheres).
 - Equipment intended to be used in vehicles, on board ships or aircraft, in tropical countries or at altitudes greater than 2000 m.
 - Equipment intended for use where ingress of water is possible.
- 5) Installation by qualified personnel only!
- 6) The product is a component intended for installation and use in complete equipment. The final acceptance of the component is dependent upon its installation and use in complete equipment.

POLYCOM	ED	2.0	DATE	29-06-2011	SIGN	HBR		Page 12 of 12
	Model no.: KT4586				141993XX-DS			