



**Beta Draft—Confidential**



# **Polycom<sup>®</sup> SpectraLink 8400 Series Wireless Handset User Guide**



## Patent Information

The accompanying product is protected by one or more US and foreign patents and/or pending patent applications held by Polycom, Inc.

## Copyright Notice

© 2011, Polycom, Inc. All rights reserved. POLYCOM®, the Polycom "Triangles" logo and the names and marks associated with Polycom's products are trademarks and/or service marks of Polycom, Inc. and are registered and/or common law marks in the United States and various other countries. All other trademarks are property of their respective owners. No portion hereof may be reproduced or transmitted in any form or by any means, for any purpose other than the recipient's personal use, without the express written permission of Polycom.

All rights reserved under the International and pan-American copyright Conventions.

No part of this manual, or the software described herein, may be reproduced or transmitted in any form or by any means, or translated into another language or format, in whole or in part, without the express written permission of Polycom, Inc.

Do not remove (or allow any third party to remove) any product identification, copyright or other notices.

Every effort has been made to ensure that the information in this document is accurate. Polycom, Inc. is not responsible for printing or clerical errors. Information in this document is subject to change without notice and does not represent a commitment on the part of Polycom, Inc.

## Notice

Polycom, Inc. has prepared this document for use by Polycom personnel and customers. The drawings and specifications contained herein are the property of Polycom and shall be neither reproduced in whole or in part without the prior written approval of Polycom, nor be implied to grant any license to make, use, or sell equipment manufactured in accordance herewith.

Polycom reserves the right to make changes in specifications and other information contained in this document without prior notice, and the reader should in all cases consult Polycom to determine whether any such changes have been made.

NO REPRESENTATION OR OTHER AFFIRMATION OF FACT CONTAINED IN THIS DOCUMENT INCLUDING BUT NOT LIMITED TO STATEMENTS REGARDING CAPACITY, RESPONSE-TIME PERFORMANCE, SUITABILITY FOR USE, OR PERFORMANCE OF PRODUCTS DESCRIBED HEREIN SHALL BE DEEMED TO BE A WARRANTY BY POLYCOM FOR ANY PURPOSE, OR GIVE RISE TO ANY LIABILITY OF POLYCOM WHATSOEVER.

## Contact Information

Please contact your Polycom Authorized Reseller for assistance.

Polycom, Inc.

4750 Willow Road,

Pleasanton, CA 94588

<http://www.polycom.com>

## Model Numbers and Product Compatibility

The information in this document pertains only to SpectraLink 8400 Wireless Telephones, Battery Packs, and chargers. All 8400 Series products are compatible with each other. Use only 8400 Series products with other 8400 Series products as identified by the model number located on the label of the product. If you have any questions about product compatibility, contact your system administrator.

<b>Product</b>	<b>Model Number</b>
SpectraLink 8440 Wireless Telephone	8440
SpectraLink 8450 Wireless Telephone	8450
USB Charger	SA106B-05
Dual Charger	DCA39
Quad Charger	DCA40
Standard Capacity Battery Pack	RS657
Extended Capacity Battery Pack	RS658

Information in this document is valid as of the current product beta release date and is subject to change without notice pending the final product release.



---

# Contents

- Chapter 1: Understanding Your Handset ..... 1**
  - Communication Type ..... 1
    - Telephone Calls* ..... 1
    - Paging and Push-to-Talk (PTT) Broadcasts* ..... 1
    - Instant Messaging Chats* ..... 1
    - Application Alerts* ..... 2
  - The Session Manager ..... 2
  - Features of Your Handset ..... 4
    - Front View* ..... 4
    - Back View* ..... 5
    - Left Side View* ..... 5
    - Right Side View* ..... 6
    - LED Indicator* ..... 6
- Chapter 2: Before Using Your Handset ..... 7**
  - Charging the Battery Pack for the First Use ..... 7
  - Powering Up and Powering Down Your Phone ..... 7
  - Using the Headsets and Speakerphone ..... 7
    - Pairing and Using a Bluetooth Headset* ..... 8
    - Hearing Aid Compatibility* ..... 10
  - Handset Registration ..... 10
  - Normal Initialization Process ..... 11
  - Login Requirements ..... 11
  - Restarting and Updating Your Handset ..... 12
- Chapter 3: Getting Started ..... 13**
  - The Home Screen ..... 13
  - Home Screen Icons ..... 14

<i>Contacts / Call Lists</i> .....	14
<i>Messages</i> .....	14
<i>Settings</i> .....	15
<i>Applications</i> .....	15
Shortcut Menus.....	16
Status Bar Icons.....	16
How to Navigate Screens, Menus, and Sessions .....	18
How to Enter Text, Numbers, and Special Characters.....	19
<i>Entering and Editing Data</i> .....	20
Locking and Unlocking the Keypad .....	21
<b>Chapter 4: Using Telephony Applications .....</b>	<b>23</b>
How to Make Calls .....	23
<i>Making an Emergency Call</i> .....	23
<i>Multiple Call Methods</i> .....	23
How to Use the Dialer .....	24
<i>Opening the Dialer from the Home Screen</i> .....	25
<i>Opening the Dialer from the Session Screen</i> .....	26
How to Answer Calls .....	26
<i>Notification</i> .....	26
<i>Incoming Call Management</i> .....	27
Handling Active Calls.....	28
<i>Session List Icons</i> .....	29
How to Transfer a Call and Set up Conference Calls .....	30
Managing Conference Calls .....	33
Forwarding Calls.....	35
Enabling and Disabling Do Not Disturb (DND) .....	37
<i>Enabling and Disabling DND on All Lines</i> .....	38
<i>Enabling and Disabling DND for Single Lines</i> .....	38
How to Use Speed Dial Lists.....	39
Accessing Voicemail .....	40

<b>Chapter 5: Push-to-Talk (PTT) and Paging.....</b>	<b>42</b>
Push-to-Talk .....	42
<i>Receiving and Transmitting PTT Broadcasts.....</i>	<i>42</i>
<i>PTT Configuration .....</i>	<i>45</i>
<i>Setting PTT Alerts.....</i>	<i>47</i>
Paging Contacts.....	47
<i>Paging Groups.....</i>	<i>48</i>
<i>Sending and Receiving a Page .....</i>	<i>48</i>
<i>Paging Configuration .....</i>	<i>50</i>
<b>Chapter 6: How to Use the Contact Directory.....</b>	<b>53</b>
Contact Directory Fields.....	53
Managing Your Contacts.....	54
Using Call Lists.....	56
Searching and Saving with the Corporate Directory .....	58
<i>Searching the Corporate Directory .....</i>	<i>58</i>
<i>Saving Corporate Directory Search Results.....</i>	<i>58</i>
<b>Chapter 7: Instant Messaging.....</b>	<b>60</b>
Understanding IM Contact Names .....	60
Understanding IM Status Icons.....	61
Initiating an Instant Messaging Session.....	62
<i>Understanding the Chat Window .....</i>	<i>63</i>
Managing Instant Message Sessions .....	63
Reading and Managing Stored Messages.....	65
<b>Chapter 8: Using the Calendar.....</b>	<b>66</b>
<b>Chapter 9: Using the Barcode Reader (8450 only) .....</b>	<b>70</b>
General Operating Instructions .....	70
Using the One-to-one Application .....	71
Using the Many-to-Many Application.....	72
<b>Chapter 10: Applications.....</b>	<b>73</b>

How to Use the Handset While in a Web Application .....	73
Custom Applications .....	73
<b>Chapter 11: Customizing your Handset .....</b>	<b>75</b>
Customizing a Profile .....	76
<i>Changing the Ring Settings for Telephone Calls .....</i>	<i>76</i>
<i>Setting Unique Ring Tones for Contacts .....</i>	<i>77</i>
<i>Change the Alerting Characteristics.....</i>	<i>77</i>
<i>Changing the Ring Settings for OAI Applications.....</i>	<i>77</i>
<i>Changing the Alerting Characteristics for PTT.....</i>	<i>78</i>
Customizing the Handset Display and Other Preferences.....	78
<i>Adjusting the Backlight .....</i>	<i>80</i>
<b>Chapter 12: Charging Your Handset .....</b>	<b>81</b>
Charging the Battery Pack.....	81
Charger Options .....	81
<i>Quad Charger .....</i>	<i>82</i>
<i>USB Charger .....</i>	<i>82</i>
<i>Dual Charger .....</i>	<i>83</i>
About Battery Packs.....	84
<b>Appendix A: Troubleshooting.....</b>	<b>88</b>
<b>Appendix B: Cleaning and Drying the Handset .....</b>	<b>89</b>
<b>Appendix C: User Settings Menu .....</b>	<b>91</b>
<b>Appendix D: Icon Table .....</b>	<b>96</b>
<b>Appendix E: Safety Information .....</b>	<b>97</b>
Industry Canada Notice.....	97
Chargers and Battery Packs .....	98
Wireless Telephones.....	99
<i>Operational Warnings.....</i>	<i>99</i>
Electromagnetic Interference and Compatibility .....	100



*Use While Driving*..... 100

*FCC Statement*..... 101

Specific Absorption Rate (SAR) Information for SpectraLink 8400 Series Wireless Telephones  
..... 101

**Appendix F: End User License Agreement for Polycom Software..... 103**



# Chapter 1: Understanding Your Handset

---

This user guide to the Polycom SpectraLink 8400 Series Wireless Handset includes overview information for beginners and for experienced users wanting to use their phones more proficiently.

In this chapter, you will learn about the four types of communication sessions your handset supports and how their alerting methods differ. To maximize the capabilities of this device, you will also learn about the Session Manager, and how you can organize the several types of concurrent sessions.

Additionally, this chapter orients you to the physical features of the handset.

Your handset will work within your facility only when it is in contact with the LAN. It will not work beyond the coverage area of the wireless LAN. Contact your system administrator if you have questions about your facility's coverage area.

## Communication Type

Your handset enables you to place and receive four call types—voice telephone calls including pages, Push-to-Talk calls, custom application notifications, and instant messaging chats. Your system administrator will customize these options for your facility.

### Telephone Calls

Voice calls are the familiar calls that ring and which you answer in the time-honored way. You can identify voice telephone calls in the Session Manager by the handset call icons.

### Paging and Push-to-Talk (PTT) Broadcasts

A paging call is a special type of call sent to a specified group of recipients. You can send and receive pages on your handset if your system administrator has programmed this feature. Pages use the PTT icon.

When configured in your facility, PTT broadcasts deliver a voice message on a channel that is available to recipients by subscription. You can identify PTT broadcasts in the Session Manager by the PTT icon.

### Instant Messaging Chats

When configured for use in your facility, instant messaging (IM) enables you to chat with IM contacts you have entered in your directory or with contacts who start a chat with you. Presence icons in the Session Manager indicate availability and identify IM contacts.

## Application Alerts

Some facilities may use custom application alerts, such as a nurse call system in a hospital, while other facilities might use a Web browser application, such as a Webcam. To see which custom applications are available, view the Application icons in the Home Screen of the Session Manager.

Your system administrator will give you information about the custom applications available on your handset.

## The Session Manager

Use your handset to manage up to eight communication sessions - calls, broadcasts, chats, and alerts - at any one time and in any combination. Each communication session displays as a color-coded cell on the Session Manager screen. Cells display with a call icon indicating call status, line number, the name and extension/channel of the party, and the call duration, as shown next:

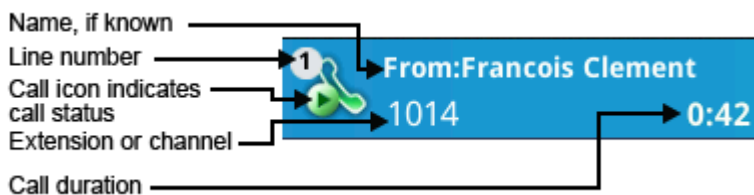

Cell color indicates cell status.

- **Dark blue** Indicates a session is on hold
- **Green** Indicates a session is active while another cell is highlighted
- **Light blue** Indicates a session is highlighted

When a cell is highlighted, soft keys display that you can press to affect that call while other cells remain unaffected. Use the ▲ and ▼ navigation keys to scroll to and highlight a cell.

In the example shown next, the Screen Manager on the left shows a blue call cell showing that the call is active. Note the active call icon and the soft keys – you can put this call on hold, mute the audio, change your speaker options, or access other features. The Screen Manager on the right shows a green call cell that is active - note the active call icon - but the other call on hold is highlighted. Since the blue call is on hold, the Resume soft key option displays. As the Mute and Speaker options do not pertain to a call on hold, these soft keys do not display. The Features soft key remains pertinent and therefore visible for both active and held calls.



In another example, suppose you have a conference call with two other people, an incoming PTT broadcast, an application on hold, and an instant messaging chat. You can display up to eight session cells with four visible at once. Scroll with the navigation keys to view and highlight the other cells.

Whenever you are at the Home screen and there are active sessions, a banner displays to indicate that the Back key will return the display to the Session Manager.

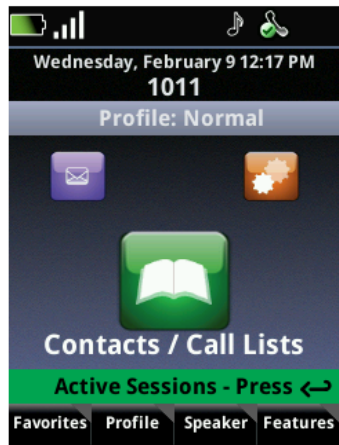

## Features of Your Handset

The front, back, and side views of your handset will orient you to the location of the keys, buttons, and other physical features documented in this guide.

### Front View



## Back View



## Left Side View

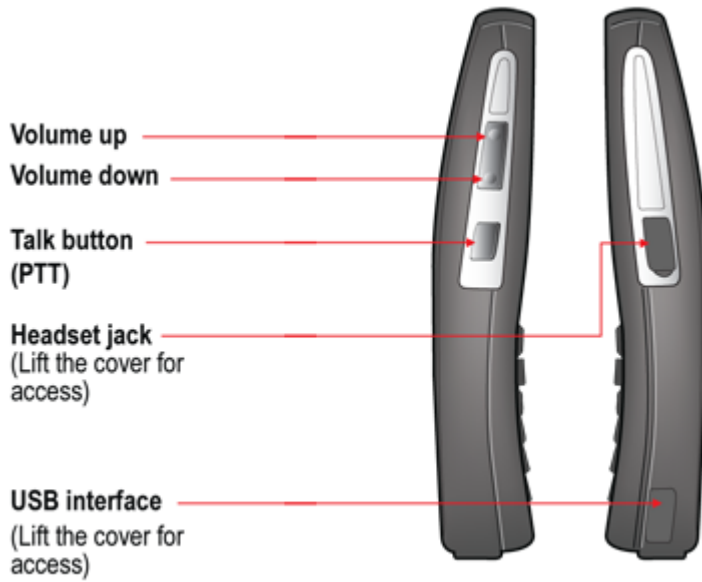

## Right Side View

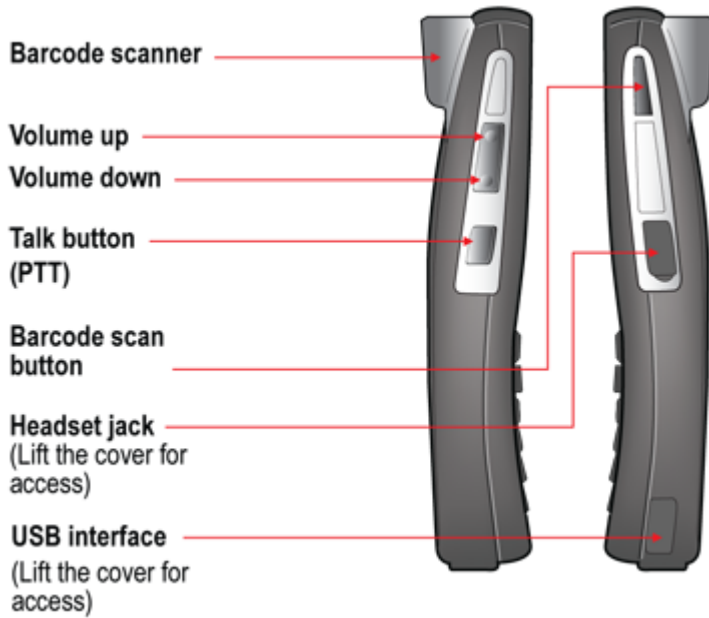

## LED Indicator



The LED indicator, located at the top right of the handset, indicates the following conditions:

- **Steady even blink** Indicates incoming telephony call to your handset
- **Slow uneven blink** Indicates voicemail/IM message
- **Quick uneven blink** Indicates inadequate Wi-Fi signal strength



# Chapter 2: Before Using Your Handset

---

When you first receive your handset, you need to fully charge the Battery Pack. You may also need to familiarize yourself with turning the handset on and off, and learn about the various audio options available to you. Additionally, your facility may have security standards that require you to enter your unique credentials, such as a domain name, user name, and password, so that the handset will correctly register with your system. This chapter covers all of these subjects.

## Charging the Battery Pack for the First Use

Take a moment to learn how to charge your phone properly. It is critical to fully charge the Battery Pack before the first use of the handset in order to maximize the Battery Pack's storage capacity and lifespan. The Battery Pack is fully charged when the Battery Pack icon becomes solid green. See **Chapter 12: Charging Your Handset**.

## Powering Up and Powering Down Your Phone

Once the Battery Pack is fully charged, you use the red End key to power up and power down the phone. Press and hold the **End** key for about two seconds to turn on and turn off the handset.



Do not remove the Battery Pack to power off the handset, as you will lose personal data. If you need to replace the Battery Pack, log off or power off the handset and then remove the Battery Pack.

## Using the Headsets and Speakerphone

Whenever the Speaker soft key displays, you have access to different audio options. When you press the Speaker soft key, the following list of options displays:

- **Speaker** The handset features a speaker in the back of the handset that turns the handset into a speakerphone. You can direct audio through this speaker by pressing the Speaker option. Use the volume keys on the left side of the handset to adjust the volume.
- **Receiver** The receiver speaker is the default speaker you hear when you hold the handset to your ear. It is located at the top of the handset above the display. If another option is in use, return to the receiver by selecting the Receiver option from the Speaker soft key menu.

- **Headset** When you plug a headset into the headset jack on the right side of the handset, audio is automatically routed through it. The headset jack is unavailable when the handset is docked in the Dual Charger (DCA39). The headset jack accepts a four-conductor 2.5mm TRS plug.
- **Bluetooth** If the system administrator enables Bluetooth capability, the Bluetooth option will display on the Settings menu. You must pair and then connect Bluetooth devices before you can hear audio through the headset.

## Pairing and Using a Bluetooth Headset



Bluetooth devices vary. The following instructions are intended as a guide, and may not apply to your Bluetooth device.

### To pair your Bluetooth headset with your handset:

- 1 Turn on the handset. Navigate to **Settings > Basic Settings > Bluetooth**. You must first turn Bluetooth on, and then pair and connect the headset.



- 2 Select the **Bluetooth On Off** option and turn Bluetooth on. When Bluetooth is turned on, the Bluetooth icon displays in the status bar.
- 3 Place the Bluetooth headset in discovery mode. To put the Bluetooth in discovery mode, remove the headset and hold down the answer/end button. The indicator light will flash blue for several seconds before glowing a solid blue color. See the manufacturer's instructions for pairing if you have any difficulty with this step. You can usually find instructions on the Web.

4 Select **Manage BT Headsets**. A combined list of up to five connected, paired, and detected headsets displays. Your list might already be populated or it might be empty. Icon color indicates status:

- **Red icon** Indicates the listed headset is not paired



- **White icon** Indicates that the headset is paired



- **White icon with a headset** Indicates that the headset is paired and connected



5 Press the **Add Device** soft key to begin the acquire procedure. Give this list at least ten seconds to populate to allow the handset enough time to detect new devices. All nearby devices in discovery mode will be added. Once the device is paired, it will display on the list.

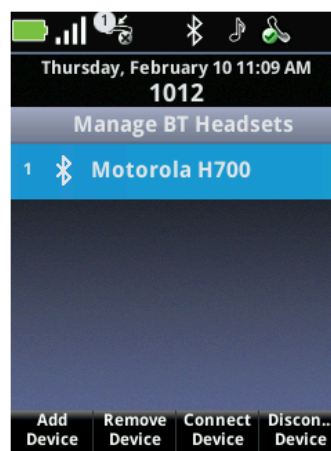
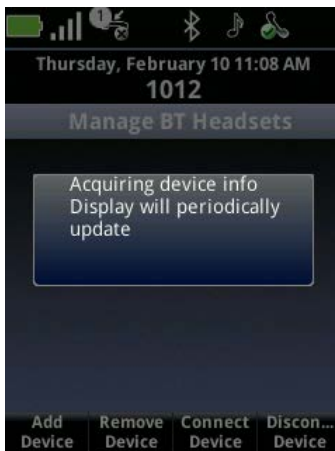

6 Now you are ready to connect the device. Press the **Connect Device** soft key. The Bluetooth headset model will display on the list with the headset icon. The headset icon will also display in the status bar.

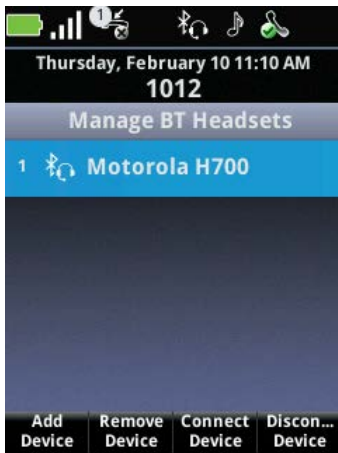

- 7 Use the **Disconnect Device** to turn off the headset. Use the **Remove Device** soft key to remove the headset from the list.

### Changing the audio option while using a Bluetooth headset

- If you press the Speaker soft key while using a Bluetooth headset, you get a shortcut menu enabling you to redirect audio through another audio path instead of the Bluetooth headset.
- If you turn off the Bluetooth headset without ending the call, the audio will be routed to the next active audio option.

### Setting Bluetooth volume:

Use the volume adjustment buttons on the headset to increase or decrease call volume.

## Hearing Aid Compatibility

Radio frequency can interfere with some hearing aids. Your handset has a hearing aid compatibility mode that adjusts the frequency response for users who have hearing aids equipped with telecoil inductive pickups. Acoustic pickup hearing aids will not respond to this adjustment.

To view the current status of the Hearing Aid Compatibility feature and to enable or disable this feature, navigate to **Settings > Basic Settings > Hearing Aid Compat....** Enable or disable as needed.

## Handset Registration

Generally, your handset will be deployed with multiple other handsets. In this case, your system administrator will configure the handset parameters beforehand so that when you turn your handset on, the handset will register with the system and be ready to use.

If your handset is not part of a large handset deployment, your handset might not be registered, in which case it will not work. Contact your system administrator if your handset does not function normally when you turn it on.

## Normal Initialization Process

The handset cycles through several steps when you first power it up. Allow it to continue until you see the Home screen and the registration icon in the status bar. You will see this sequence:

- 1 A facility logo displays for about 15 seconds.
- 2 The screen message displays: **Starting application, press Cancel to interrupt**. If you press the Cancel soft key, the startup cycle is interrupted for administrative tasks. Do not press the Cancel soft key unless directed by your system administrator.
- 3 The Home screen displays with the registration successful icon in the status bar (  ).

If registration fails, you will see an icon showing registration failed (  ). See **Table 1: Status Bar Icons** for a summary of these icons. Power cycle the handset (turn the handset off and then back on) if registration fails. Contact your system administrator if registration continues to fail after several attempts.

## Login Requirements

Two types of system environments are possible - assigned and shared - and which one your facility uses determines how you log into the wireless telephone system. Contact your system administrator if you are not sure which system environment is deployed.

- **Assigned handsets** If you have an assigned headset, your system administrator will give you login credentials - the domain, a user name, and a password - that you will need to enter when prompted to log in. With these login credentials, you can program your contacts and preferences on your assigned handset.
- Once you have entered your credentials, turning the phone off and on again will not delete them, and all calls made to/from the handset will be identified with your extension.
- **Shared handsets** With shared handsets, any handset can be used by anyone to perform basic call functions. However, if you have login credentials you can program a handset with your own preferences and contacts. This information is then associated with your login credentials and stored as yours on the system server. You can log in with any handset and access all the settings that you have previously programmed. When you log out or power down, the handset returns to its generic state.

Users not having login credentials can use a generic handset for basic call functions, but most of the features will not be available.

### To Log in:

- 1 There are three ways to log in.
  - o You can log in from the login screen.
  - o You can log in and log out by pressing the **Features** soft key from the Home screen to display a shortcut menu that includes a User Login option. This option toggles between **User Login** and **User Logout**, depending on your status.
  - o You can navigate to **Settings > Basic Settings > Login Credentials** to open the log in screen and enter your credentials.



- 2 Enter your credentials as provided by your system administrator. When entering credentials through the Settings menu, a domain name is required as the first entry. Use the **Encoding** soft key to set the text entry mode (Abc/123... and ASCII/Latin...). For help, see *How to Enter Text, Numbers, and Special Characters*. Enter the requested information.
- 3 Press the **Login** or **Submit** soft key.

## Restarting and Updating Your Handset

Customer support services or your system administrator may advise you to restart your handset or update configuration software.

### To restart your handset:

- Navigate to **Settings > Basic Settings > Restart Phone** and follow support directions.

### To update handset configuration:

- Navigate to **Settings > Basic Settings > Update Configuration** and follow support directions.

# Chapter 3: Getting Started

---

This chapter shows you how to use the Home screen, the status bar icons, the soft keys, the shortcut menus, navigation, and text entry.

## The Home Screen

The Home screen is the first display you will see. The top row of icons provides you with a visual representation of the status of the handset. The status icon list is below. The date and time display is below the status icons and the handset's extension is centered on the next row. The current profile is prominently displayed as a banner so that you know which ring settings are selected.

When you press the < or > key, the Home icons rotate to present different applications: Messages, Settings, Applications, and Contacts/Call Lists. Only three icons are visible at once. This section explains how each of these icons are used.

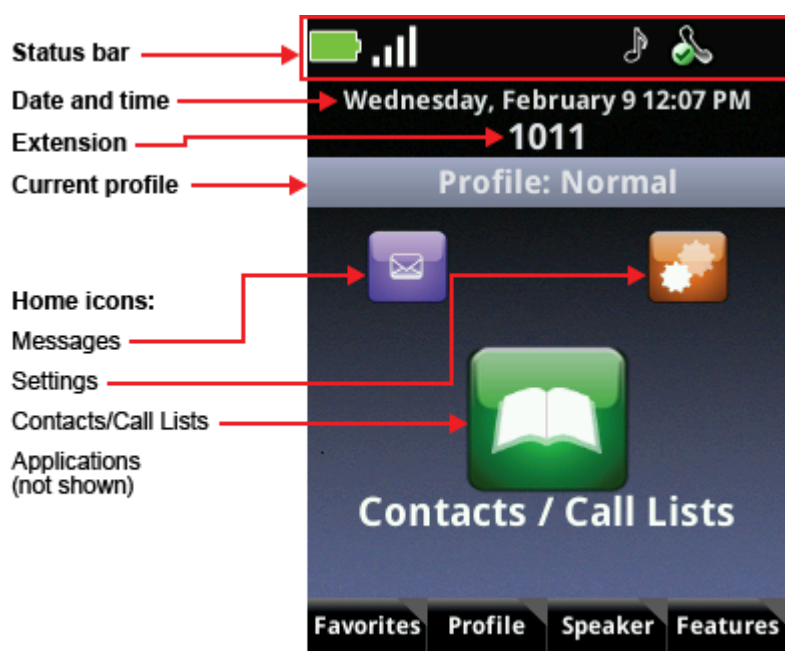

## Home Screen Icons

This section explains the four home screen icons.

### Contacts / Call Lists

The Contacts/Call Lists icon is the default icon for the Home screen. It opens the Contacts Directory and Call Lists. See **Chapter 6: How to Use the Contact Directory and Using Call Lists** for more information.



### Messages

When a facility activates voicemail and instant messaging, the calls and messages are stored in the Messages icon. See *Accessing Voicemail* and **Chapter 7: Instant Messaging** for more information.

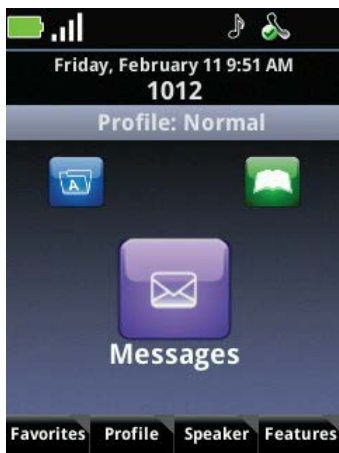



## Settings

The Settings icon opens a menu of options you can use to customize your handset. See **Appendix C: User Settings Menu** for a list of available options.



## Applications

Some facilities use custom applications for specialized functions, such as barcode reader applications or nurse call systems. For help with applications, see **Chapter 10: Applications**. Contact your system administrator if you have questions about any application listed on this menu.



## Shortcut Menus

The soft keys at the bottom of the display allow you to select functions. The gray triangles in the upper right corner of the soft keys indicate that there is a shortcut menu with additional options. Use the shortcut menus to quickly find the options you want. Press a soft key to display a shortcut menu. Use the ▲ and ▼ navigation keys to highlight an option, and choose the option by pressing **OK**. Alternatively, you can press the number of the option on the keypad to instantly activate it. Grayed options are not available.



Using the number option to open menu items is faster than highlighting the option and pressing the OK key

Here is the Feature shortcut menu that displays the feature options:



## Status Bar Icons

Icons displayed in the status bar indicate various handset conditions as defined in Table 1. Up to eight icons can display in the Status bar and each icon has a fixed position.

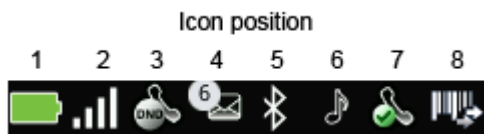





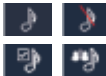



Table 1: Status Bar Icons.

Position	Icon(s)	Description
1		Battery life indicator is in the first, left-most icon position. Shown is the fully charged icon.
2		The signal strength icon in the second position shows the signal strength of an associated AP. If location services is activated in your facility, the location icon is superimposed on the signal strength icon.
3		Mute and Do Not Disturb icons share the same position. The mute indicator has priority and displays whenever the microphone is blocked from producing outgoing audio.
4		The Messages icon is displayed if either a voice or text message is waiting. The Missed Calls icon displays when you have missed calls but no voicemail has been left. Missed calls are listed in the Contacts/Call Lists.
5		Bluetooth connect status icon indicates Bluetooth availability.
6		The User Profile icon displays when no call is active: Normal, Silent, Meeting, Custom
7		The Registration icon shows that the handset is connected and operational. The green checkmark indicates successful connection. The red x indicates failure to connect. The shadow indicates the handset is registered to a shared line.
8		The barcode icon shows whether the barcode reader is connected or disconnected (for the 8450 series only).

## How to Navigate Screens, Menus, and Sessions

This section describes more advanced features of your handset.

### To return to the Home screen:

The Home screen is where the handset is idle and ready to receive or send calls. How you return to it depends on where you are.

- **Home Key** Press the **Home** key to return to the Home screen
- **Back Key** If you're at a top-level menu, press the **Back** key to return to the Home screen
- **End Key** While navigating, press the **End** key to return to the Home screen

### To return to the Session Manager:

If you leave the Session Manager when session cells are present, a banner will display along the top of the soft keys alerting you to active calls.

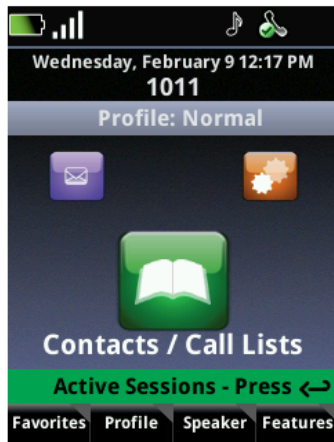

- Press the **Back** key to return to the Session Manager.

### To scroll up and down through menu options or session cells:

- Press the **▲** and **▼** keys to move the highlighter through menu options and session cells.

### To select an option:

- Press the **OK** button on the keypad interface to select the highlighted option.

### To scroll left and right through text:

- Press the **◀** and **▶** keys to move the insertion point left and right.

**To cancel the current edit session:**

- Press the **Cancel** soft key to cancel any edits and return to the previous screen.

**To return to the previous menu:**

- Press the **Cancel** soft key or **Back** key to return to the previous menu.

The **End** key executes all these actions.

- Hangs up a call
- Rejects an incoming call
- Exits a conference call
- Turns off the handset (when held down for 2 seconds)

## How to Enter Text, Numbers, and Special Characters

When dialing calls or entering contact information, you will need to enter characters other than numbers. The Mode soft key allows alphanumeric data entry and special characters (abc... 123... @#&...). The Encoding soft key allows non-Arabic characters (Japanese or Russian), as well as alphanumeric entry and special characters.

Mode soft key options:	Encoding soft key options:
1 Abc	1 Abc
2 ABC	2 ABC
3 abc	3 abc
4 123	4 123
	6 Latin
	7 Katakana
	8 Unicode
	9 Cyrillic

## Entering and Editing Data

Data entry fields display an Entry Mode soft key so you can specify how you want your entry to display.

### To enter letters and numbers:

Press the **Mode** soft key to display a shortcut menu of the available data entry options:

- Uppercase (ABC)
- Numerical (123)
- Leading caps (Abc Def)
- Lowercase (abc)

Press a keypad key one or more times to enter the characters or numbers that display on the key.

For example, if you're in ABC mode:

- To enter A, press 2
- To enter B, press 22
- To enter C, press 222
- To enter 2, press 2222

For example, if you're in 123 mode:

To enter 2, press 2.

### To enter special characters:

- 1 Select one of the alphabetic options from the **Mode** soft key menu. You cannot access special characters when you are in Numerical (123) mode.

The mode you select displays in the screen title.

- 2 Use the asterisk (\*) or zero (0) to enter characters:

\* = . \* # - & % + ;

0 = / , \_ \$ - = ? 0

### To enter text in a special language:

Press the **Encoding** soft key to display a shortcut menu of the available language options:

- **ASCII** Regular text
- **Latin** To add accented characters, for example é.
- **Katakana** Japanese characters

- o **Unicode** Stores characters as double bites
- o **Cyrillic** Russian

Press a key one or more times to enter the character you want.

**To delete text already entered:**

- Press ► or ◀ to position the cursor to the right of the text you want to delete, and then press the << soft key.



When the entry in the text box is highlighted in yellow, any new text will overwrite the existing entry. If you press the << soft key, the entire entry will be erased.

## Locking and Unlocking the Keypad

To avoid making inadvertent calls, you can lock your keypad so that key presses are not recognized. You must unlock the keypad before you can make calls.

**To lock the keypad:**

- 1 Press the **Feature** soft key.



- 2 Press the **2** key or scroll to **2 Keypad Lock**, and press **OK**. Once you lock the keypad, all the keys become frozen except for an Unlock soft key, which replaces the Features soft key.

**To unlock the keypad:**

- 1 Press the **Unlock** soft key.

## Polycom SpectraLink 8400 Series Wireless Handset

### **2** Press the **Yes** soft key.

An incoming call will automatically unlock a locked keypad for the duration of the ring period and restore normal keypad operation. If you do not answer the call, the keypad immediately locks upon termination of the ring period.



# Chapter 4: Using Telephony Applications

---

The handset enables multiple ways of making calls and several options for handling an incoming call.

## How to Make Calls

There are several ways to make a call. When you hear a dial tone, the handset is in the active mode. Once a call starts ringing, an incoming call window displays. If you ignore the call, the Session Manager opens and the ringing icon will display at the left side of the call cell until the end of the ring period. You may abort the call by pressing the **End** key.

## Making an Emergency Call

If an emergency number has been assigned for your facility, you can access it from the Home screen.

### To make an emergency call:

- 1 Press the **Features** soft key.
- 2 Press **3** or scroll to the **Speed Dial** option and press **OK**.
- 3 Scroll to the emergency number and press **OK**.

## Multiple Call Methods

You can use your handset to start a call in several ways.

### To call by entering a number:

Dialing by handset number is the default mode. Press any number on the keypad to open the Dialer. See *How to Use the Dialer* below for complete instructions.

### To call a contact:

You can call one of the entries in your Contacts Directory. See **Chapter 6: How to Use the Contact Directory**.

### To call from a call list:

You can place a call to a received, missed, or placed call. See *Using Call Lists*.

### To call from a directory:

Open the list and select the contact you would like to call and press the **Info** soft key. When the screen displays, press the **Dial** soft key. For more information, see **Chapter 6: How to Use the Contact Directory**.

### To call from the speed dial list:

To place a speed dial call from the Home screen press the **Favorites** soft key. This opens a list of the first three speed-dial contacts.



You can select one of these names or use the keypad to press a speed-dial index number. The call is placed immediately. See *Enabling and Disabling DND on all lines when single line DND is enabled*.

Once you enable one line with DND, the Set All and Clear soft keys display. Press one of these to enable or disable DND for all lines.

### How to Use Speed Dial Lists

- Once you enable one line with DND, the Set All and Clear All soft keys display. Press one of these to enable or disable DND for all lines.

See *How to Use Speed Dial Lists* for more information about how to set up your speed dial list.

### To call by entering an IP address or URL:

You can call by entering an IP address or URL dialing in the Dialer. For more information, see the next section.

## How to Use the Dialer

The Dialer is the screen that opens when you start to dial a number using the various methods described next.

### Autocomplete Feature

The Autocomplete feature filters the list of stored names and numbers and displays them according to the characters you have started to dial.

If the name or number of the person you are trying to call displays on this list, highlight the cell by scrolling to it and place the call by doing one of these:

- Press and hold the **OK** key.
- Press **Start**.
- Press the **OK** key to pop the highlighted number into the entry window, and then press **Start**.

If you are in an active call and placing a second or third call, the Autocomplete cells replace the other session cells until the new call begins to ring.

## Numeric Dialing

Phone numbers and URL addresses are limited to number characters.

### Dialing to a URL

When you select URL dialing from the Entry Mode soft key, the prefix **SIP** is displayed at the start of the number. Enter the IP address after this prefix. The address could be a number somewhere on the Internet, or it could belong to one of your contacts, or it could be a recently received call. If the address belongs to a contact, or the phone has recently received a call from the address, Autocomplete will filter the cells so you can select it.

### Dialing Contact Names and IM Names

The Entry Mode soft key allows you to enter letters, special characters, and supported language characters that may be required for entering a name, an IM name, or an IM address. The name you enter must match a name in the Contact Directory in order to begin dialing.

## Opening the Dialer from the Home Screen

You have several ways to open the Dialer while working in the Home screen. You can press a number key or the Start key, select a line key, or select an audio path. Use one of the following procedures.

### Press a Digit Key (Predial)

Press a digit key (0-9) to start dialing, and the Dialer opens to display the number in the dial cell. This is predialing. The call will be placed when you finish entering the numbers or select the Autocomplete cell and press Start or OK. You can enable or disable Predial in the Settings menu. See *On-Hook Dialing* and **Appendix C: User Settings Menu**.

### Press the Start Key

Press the **Start** key to open the Dialer and listen for a dial tone. You can enter the number manually or select the number from the Autocomplete list as you begin to dial.

## Select a Line

Press the **Features** soft key, select the **Lines** option, and then select the line you wish to use. The Dialer opens and you hear a dial tone. You can enter the number manually or select the number from the Autocomplete list as you begin to dial.

## Select an Audio Path

Press the **Speaker** soft key and select an audio path from the available options. The Dialer opens and you hear a dial tone. You may enter the number manually or select it as you dial from the Autocomplete list.

## Opening the Dialer from the Session Screen

When you are in an active call and wish to place another call, you can open the Dialer in several ways as explained next. While you are dialing, the Autocomplete cells replace the other session cells until the new call begins to ring.

### Press a Digit Key (Predial)

Press a digit key (0-9) to start dialing, and the Dialer opens to display the number in the dial cell. This is predialing. Continue to enter the number manually or select a cell from the Autocomplete list.

### Press the Start Key

Press **Start** to open the Dialer and get a dial tone. The active call is automatically placed on hold while you complete the new call.

When opening from the Start key, the Dialer displays a blank cell for manually entering a number and three more cells that display the three contacts most recently called from the contact list. You may enter the number manually, select it from the list of contacts, or select it as you dial from the Autocomplete list.

## How to Answer Calls

Several options are available for you to manage the call – you can answer it, ignore it, silence the ring, send it to voicemail, forward it, divert it, and transfer it. This section explains each of these options.

## Notification

Many different ring settings are available to alert you to an incoming call. The handset speaker notifies you of incoming calls unless it has been silenced (see *Changing the Ring Settings for Telephone Calls*). If you are wearing a headset, you will hear an in-ear notification instead of a ring.

While the phone is ringing, you can increase or decrease the ring volume using the volume buttons. The new volume setting will be maintained and used whenever the handset rings until you log off or power cycle the handset (turn the handset off and then on again). Ring volume will revert to the volume set for the Profile when you turn on the handset.

### Multi Key Answer Feature

If the handset is in Multi Key Answer mode, you can answer an incoming call by pressing any keypad key (0-9, \*, #), or the Start key. The Multi Key Answer feature works only when the Incoming Call window displays. You can enable/disable Multi Key Answer in the Settings menu. See the Settings table in *Appendix C: User Settings Menu* or see *Multi Key Answer* for help navigating to this feature.

## Incoming Call Management

When you are alerted to an incoming call the handset gives you several ways of managing the new call and any existing calls.



### Silence the ring:

- Press the **Ignore** soft key to silence the ring. The call will display in the Session Manager until it stops ringing. If unanswered, it will be routed to voicemail, if available.

### Answer an incoming call by putting a current call on hold:

- 1 Press **Ignore** to open the Session Manager. Your current call will be highlighted.
- 2 Press the **Hold** soft key to place the current call on hold and highlight the incoming call cell.
- 3 Press **Start** to answer the incoming call.

### Answer an incoming call by ending the current call:

- 1 Press **Ignore** to open the Session Manager. Your current call will be highlighted.

## Polycom SpectraLink 8400 Series Wireless Handset

- 2 Press **End** to end the current call and hear the incoming call ring.
- 3 Press the **Start** key to answer the incoming call.

### Reject the incoming call:

- Press **End**. If voicemail is available, the call will be routed to voicemail.

### Forward the incoming call to another number:

- Press the **Forward** soft key. See *Forwarding Calls* for complete information.

### Ending calls:

- After you have finished your conversation, press **End** to end or hang up an active call.



To abort an outgoing call while it is ringing, press the End key.

## Handling Active Calls

When you are in an active telephony call, the Session Manager displays each call in a separate cell, as shown in the next example:

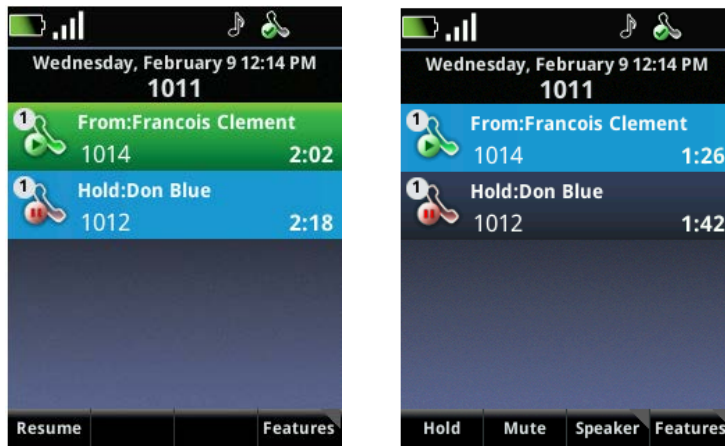











An active call has a light blue field when it is highlighted. An active call has a green field when another session cell is highlighted. Soft key presses affect highlighted cells. In the above example, you can see how the soft keys change when you highlight an active call.

## Session List Icons

Icons display on the left side of the call cell to indicate the status of that call. The number indicates which line the call is using.

**Table 2: Session List Icons.**

Icon	Description
	Incoming call ringing
	Call active
	Call on hold
	Conference call
	Conference leg
	PTT/Page receive
	PTT/Page transmit
	PTT/Page idle
	PTT/Page hold
	IM Presence indicator

### Holding and resuming calls:

- During an active call, the active call icon and the Hold soft key display. Press the **Hold** soft key to place the call on hold.
- When you place a call on hold, the call-on-hold icon and the Resume soft key both display. Press the **Resume** soft key or the **OK** key to resume the call.
- If you have more than one call on hold, use the **▲** and **▼** keys to highlight one of them, then press the **Resume** soft key or **OK** to make it an active call.

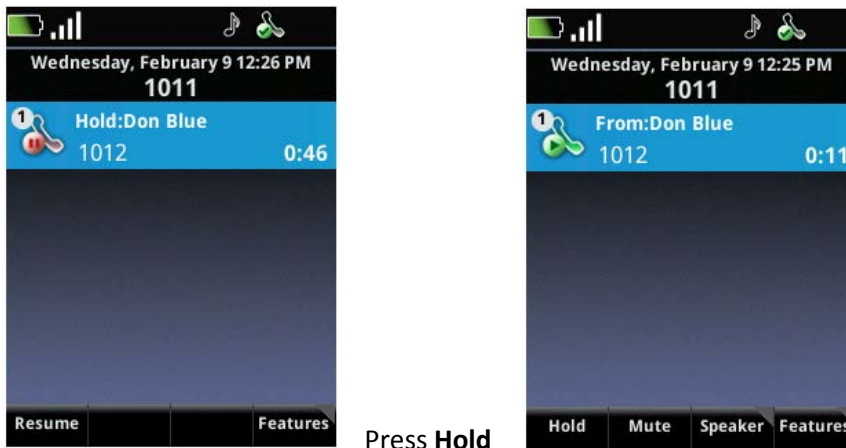

### Muting a call:

- To mute yourself in the call, press the **Mute** soft key. A mute icon displays in the status bar. Now you can still hear the other party, but that person can't hear you. Press **Resume** to resume audio flow.

### Activating the speakerphone:

- To activate the speakerphone, press the **Speaker** soft key and select the **Speakerphone** option.

## How to Transfer a Call and Set up Conference Calls

A transfer connects two parties as you exit the conversation, leaving the two other parties connected. Your handset can perform three types of transfers:

- **Blind** A blind transfer exits the call before the two other parties are connected, while the second party is ringing.
- **Consultative** A consultative transfer enables you speak to the party the call is being transferred to before completing the transfer.
- **Attended** An attended transfer connects all three parties, as in a conference call, before you hang up.

### Performing a Blind Transfer

While in an active call, or with the call on hold:

- 1 Open the **Features** shortcut menu and select **Blind Transfer**.  
You will hear a dial tone and the Dialer will open.
- 2 Place the call to the target party. (See *How to Use the Dialer*.)



Once you dial a call, the transfer is complete and you are returned to the Home screen whether or not the other party answers the call. If there are other active sessions, you will be returned to the Session Manager.

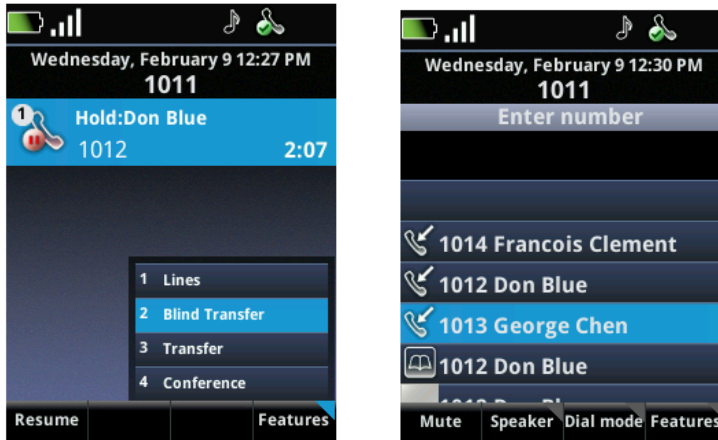

### Performing a Consultative or Attended Transfer

A consultative transfer does not establish a connection between the current call and the target call but you can talk to either party until you select the Transfer option. An attended transfer establishes a conference call first so all parties can talk to each other before you hang up.

#### Beginning a transfer:

- 1 While in an active call or with the call on hold and highlighted, press the **Features** soft key and select **Transfer**.
- 2 Place a call to the target party. (See *How to Use the Dialer*.)
- 3 When the target party answers, explain that you are going to transfer the call.

#### Completing a consultative transfer:

- Select **Transfer** from the **Features** shortcut menu.

You are returned to the Home screen or, if other calls are active, to the Session Manager.

#### Completing an attended transfer:

- 1 To complete an attended transfer, select **Conference** from the **Features** shortcut menu.  
All parties are now in conference. You may optionally have a conversation.
- 2 To exit the call, ensure the conference cell is highlighted (light blue) and press **End**.

After exiting, you are returned to the Home screen or, if other calls are active, to the Session Manager.



Note that if you press End while a participant's cell is selected, you will cut that person's connection and hang up on that call.

## Setting Up a Conference Call

You can establish a conference call so that several parties can converse at once. Although three parties is the default - you and two other parties - the system administrator can increase the maximum number of participants. Contact your system administrator for more information about the maximum number of participants you can connect by conference in your facility.

### Setting up a conference call:

- 1 While in an active call or with the call on hold and highlighted, press the **Features** soft key and select **Conference**.
- 2 Place a call to the target party. (See *How to Use the Dialer*.)
- 3 When the target party answers, explain that you are going to set up a conference call.
- 4 Select **Conference** from the **Features** shortcut menu. All parties are now in conference.
- 5 If you cannot connect more than three attendees, you may add additional attendees as described next.



## Managing Conference Calls

Once you have set up a conference call, you can manage the conference call in several ways.



The system administrator determines the maximum number of participants that can share a conference call. Three is the default.

### Adding participants to a conference call:

- 1 Press the **Features** soft key.
- 2 Choose the **Conference** option. The Dialer opens.
- 3 Dial the number of the party you wish to add.
- 4 Press the **Conference** soft key when the party answers.

### Muting, holding, and resuming conference calls:

- Highlight the Conference cell before pressing any soft key. The Mute, Hold, and Resume soft keys operate in conference calls as they do for other telephony calls.
- Press the **Hold** soft key to place all parties on hold. Press the **Resume** soft key to continue the conference. When you press the Mute soft key, only your microphone is muted.

### Managing a conference call participant:

- To remove a participant from the conference, highlight the party's cell and press the **Remove** soft key.
- To mute a participant, highlight the party's cell and press the **FarMute** soft key.
- To place a participant on hold, highlight the party's cell and press the **Hold** soft key.

## Polycom SpectraLink 8400 Series Wireless Handset



### Exiting a conference call:

- To exit a conference call, highlight the conference call cell and press **End**. The other parties remain connected as in an attended transfer.

### Splitting conference calls into two calls on hold

- During a conference call, highlight the conference call cell and press the **Features** soft key. Select the **Split** option.

The conference ends, and all calls are split into individual calls and put on hold.

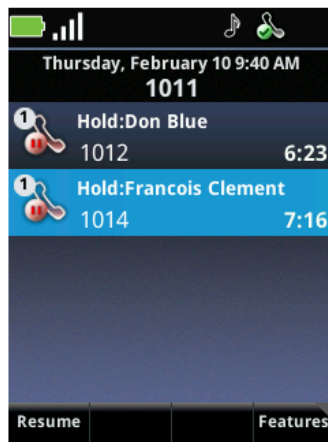
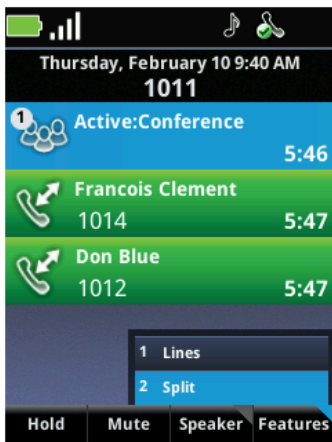

## Forwarding Calls

You can forward calls manually or automatically. A manually forwarded call is a call that you send to another number as it is ringing. You can automatically forward calls using the Settings menu to set up your forwarding criteria. Both methods are shown next.



Automatic call forwarding works only as long as you turn on and register your handset. If you turn off your handset or move out of range for an extended period of time,, calls to your handset are neither received nor forwarded. Depending on the PBX at your site, the caller might hear unending ringback tones or a recorded message such as “The party you have called is not available.”

### Forwarding calls while they are ringing:

You can manually forward a call to another number while your handset is ringing.

- 1 While the handset is ringing, select the Forward soft key. The Forward-to-Dial screen displays the last number you forwarded calls to (either statically or dynamically). If you would like to forward the call to a different number, enter the target number as you would through the Dialer. Be quick about this sequence as you only have the ring period to accomplish the forward.



- 2 When the desired number displays, press **OK**. The incoming call is forwarded to the other party and you are disconnected.

### Setting up Automatic Call Forwarding:

You can set up your handset to automatically forward all incoming calls to another number.

- 1 From the Home screen, navigate to **Settings > Feature Settings > Forward**. If your handset is set up with a single line, go to *Enabling and Disabling DND for Single Lines*. If you have call forwarding set up for multiple lines, go to step 2.



- 2 If you have multiple lines, select **Line**. The Line Select screen displays.
- 3 Highlight the line you wish to set up with call forwarding, and press **OK**.

If you've selected a line, or if your handset is set up with a single line, the Forwarding Type Select screen displays, allowing you to select the forwarding type you want.

- 4 Set the forwarding option by highlighting one of these forwarding options:
  - o **Always** To forward all incoming calls
  - o **No Answer** To forward all unanswered incoming calls
  - o **Busy** To forward calls that arrive when you're already on a call

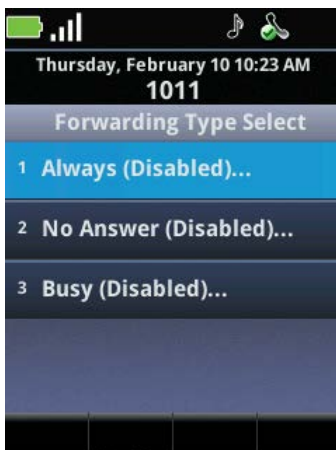

Press the **OK** key.

- 5 Depending on your selection, do one of the following:
  - o If you selected Always, enter the forwarding number.
  - o If you selected No Answer, then enter a forwarding number and then select **Forward After Rings**, and enter how many rings should be played before forwarding the call (one ring is about 6 seconds). A value of 2 is recommended.
  - o If you selected Busy, enter a forwarding number for calls that come in when you're in another call.



You can also enter a forwarding URL or IP address. For more information on using a URL or IP address, see *How to Make Calls*.

- 6 Press the **Enable** soft key to confirm call forwarding.
- 7 Press **Home** to return to the Home screen.

#### To Disable Call-Forwarding:

- 1 From the Home screen, navigate to Settings > Feature Settings > Forward. If your handset is set up with a single line, go to step X. If you have call forwarding set up for multiple lines, go to step 2.
- 2 If you have multiple lines, select **Line**. The Line Select screen displays.
- 3 Highlight the line you wish to set up with call forwarding, and press **OK**, as shown below.
- 4 If you've selected a line, or if your handset is set up with a single line, the Forwarding Type Select screen displays, allowing you to select the forwarding type you want. Highlight the forwarding type that's enabled and press the **Disable** soft key.
- 5 Press **Home** to return to the Home screen.

## Enabling and Disabling Do Not Disturb (DND)

Do Not Disturb (DND) is an optional feature that your system administrator sets up. Your system may not support it. For more information, contact your system administrator.

By default, the DND feature, when set up, applies to all lines on your handset (you can't apply DND to just one line). The system administrator can enable your handset to apply DND on a line-by-line basis. This section explains how to enable and disable the DND feature for all lines and for single lines. For more information, contact your system administrator.

While DND is enabled, calls you receive are logged in your Missed Calls list. If you have also chosen to forward your calls to another number, calls will be sent to that number.

## Enabling and Disabling DND on All Lines

The DND feature, when set up, applies by default to all lines on your handset.

### Enabling DND on all lines

- From the Home screen, navigate to **Settings > Features > Do Not Disturb** and press **OK**. DND is now enabled and the DND icon displays on the status bar.

### Disabling DND on all lines

- From the Home screen, navigate to **Settings > Features > Do Not Disturb** and press **OK**. DND is now disabled and the DND icon does not display on the status bar.

## Enabling and Disabling DND for Single Lines

If your handset is set up with multiple lines and the system administrator has enabled your handset to apply DND to single lines, follow these steps to enable or disable DND on one or more lines.

### Enabling DND on a single line when DND for a single line is enabled:

- 1** From the Home screen, navigate to **Settings > Features > Do Not Disturb**.  
When you select the DND feature, the Line Select screen displays.
- 2** Highlight the line on which you wish to activate DND and press **OK**.
- 3** Press the **Enable** soft key.

The DND icon now displays on the Line bar in the Line Select screen.

The screen returns to the Home display.

### Enabling and Disabling DND on all lines when single line DND is enabled:

- Once you enable one line with DND, the Set All and Clear All soft keys display. Press one of these to enable or disable DND for all lines.



# How to Use Speed Dial Lists

You can associate contacts with Speed Dial Keys for one-touch dialing of frequently used numbers.

## Displaying the Speed Dial List

The speed dial list can be seen in two different views. The Favorites soft key displays the lowest index numbers only. The Speed Dial option on the Features soft key displays the entire list.

### Display the entire speed dial list:

Press the **Features** soft key to display the Speed Dial option. Speed Dial keys display consecutively according to the speed dial index number (the lowest number displays first).



### Display the speed dial Favorites:

- Press the Favorites soft key.



**Calling a high index speed dial number:**

- 1 Press the **Features** soft key and select the **Speed Dial** option. The speed dial list displays.
- 2 Scroll to and select the contact you want to call and press **Start** or press the speed dial index number key associated with the contact.

**Calling a low index speed dial number:**

- 1 Press the **Favorites** soft key. The speed dial lists the lowest index numbers.
- 2 Press the number key associated with the contact.

In the previous screen example, you could call George Chen by pressing the Features soft key and then pressing 3 twice, or you could press the Favorites soft key and press the 3 key.

**Assigning Speed Dial Index Numbers**

A new entry to the Contact Directory is automatically assigned to the next speed dial index number.

**Adding Speed Dial Entries**

Each time you add a contact to your Contact Directory, a speed dial index number is assigned to the contact.

**Editing Speed Dial Index Numbers**

You may want to reorganize your speed dial index numbers. Speed dial numbers are automatically assigned when you add a contact and may be changed by editing the contact. See *To edit directory contacts* for instructions on editing a contact.

## Accessing Voicemail

Voicemail is saved in a centralized location. If your extension has a voicemail message, your handset will display the voicemail icon in the status bar and the LED will flash. The icon displays the number of unviewed messages you have.



Voicemail is an optional feature set up by your system administrator.

**Listening to voicemail:**

- 1 Navigate to **Messages > Message Center**.
- 2 If you have multiple lines:
  - a Choose **Line**. The Line Select screen displays.
  - b Highlight a line and press **OK**.

The Messages screen displays and Voicemail is highlighted.
- 3 Press **OK** to select Voicemail.
- 4 Press the **Connect** soft key to access your mail, and follow the visual prompts on the screen.
- 5 Press **Home** to return to the Home screen.

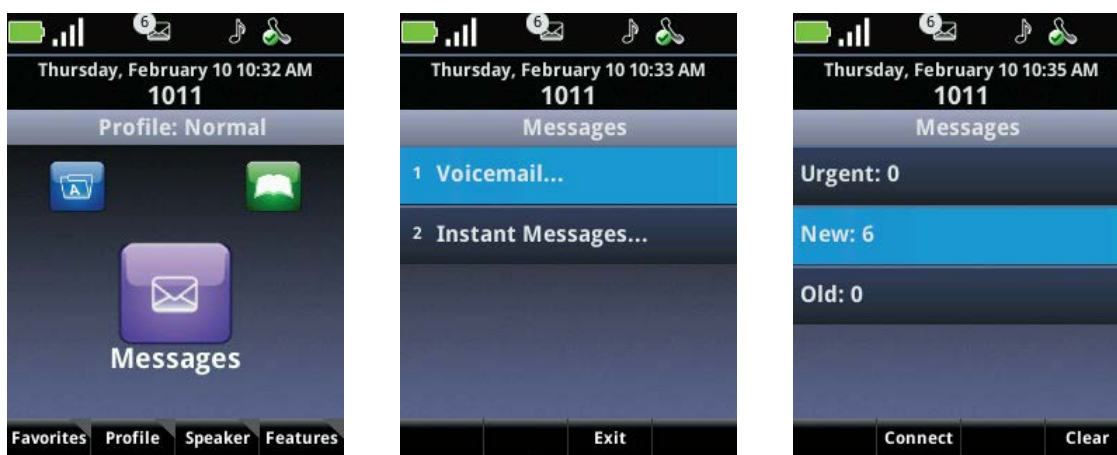
**To remove voicemail messages:**

- 1 Follow the steps in the preceding procedure to open the Message Center for the desired line.
- 2 Press the **Clear** soft key. All messages are cleared.
- 3 Press **Home** to return to the Home screen.

# Chapter 5: Push-to-Talk (PTT) and Paging

The Push-to-Talk and Paging features enable you to call as many people as have subscribed to a channel or placed in a group. Your system administrator programs both features and determines the best way to deploy these features in your facility. Contact your system administrator if you need help with these features.

You manage both features in the Settings menu. Navigate to **Settings > User Settings > Preferences > Paging/PTT Configuration** for the configuration options.

## Push-to-Talk

SpectraLink 8430 / 8440 Wireless Telephones can operate in a group broadcast mode called Push-to-Talk (PTT). Users must subscribe to channels to receive PTT broadcasts. In PTT mode, the handsets behave like walkie-talkies: a single handset can transmit to multiple listeners.

If the system administrator has disabled PTT, the PTT options will not display in the Settings menu.

## Receiving and Transmitting PTT Broadcasts

Press and release the **Talk** button to display the default channel, the last channel you used, any additional subscribed channels, and the Priority Channel.

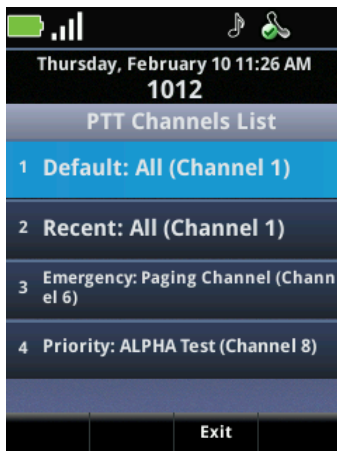

Press and hold the **Talk** button to open the default PTT channel for transmission. Release the **Talk** button to end the transmission and await reply. The handset will wait for ten seconds before reverting to standby mode. The wait period keeps the channel open and gives any handset receiving that channel time to join the conversation. To open a different channel or to send a new broadcast within the wait period, you must end the wait period on the current channel by pressing the **End** key.

**To make a PTT broadcast:**

- To broadcast on the default channel from standby mode, press and hold the **Talk** button. Wait for the display to show Transmitting and then hold the handset microphone approximately two inches from your mouth and speak. A Call cell opens in the Session Manager with a blue call icon.

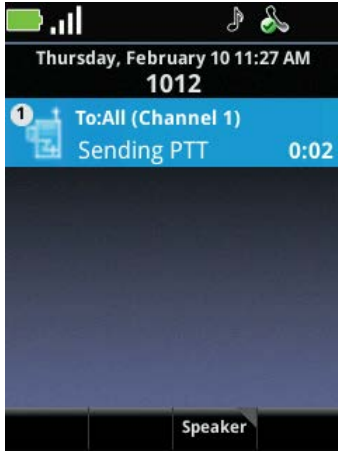

When you release the button, the handset enters a ten-second wait period during which the channel is open to receive or send additional broadcasts. If no activity occurs within the wait period, the cell is closed. A waiting cell displays an orange call icon.



**To answer a PTT broadcast:**

- Press and hold the **Talk** button during the ten-second wait period. An incoming PTT broadcast displays a green call icon.

## Polycom SpectraLink 8400 Series Wireless Handset



### To end a wait period:

- Press **End**.

### To select a different PTT channel:

- Press and release the **Talk** button. Use the ▲ and ▼ keys to highlight the desired channel. Press the **Talk** button to transmit.

### To end one PTT broadcast and start another one:

- 1 Press the **End** key to exit the PTT broadcast.
- 2 Press and release the **Talk** button and select a different channel from the list.
- 3 Press and hold the **Talk** button to begin transmitting on the different channel.

### To hear a PTT broadcast while on a telephone call:

- If Accept While Busy is disabled (see *Accept While Busy*), you will not be able to hear a PTT broadcast while you are in an active call. Press the **Hold** soft key to place the telephone call on hold. Now you can hear the PTT broadcast.

### To answer a telephone call during a PTT broadcast:

- Press the **Start** key to override a PTT transmission and answer the telephone call.

### To start a telephone call during a PTT broadcast:

- Press the **Start** key and dial the number to place the PTT transmission on hold and make a telephone call.

### To turn off PTT:

- Change to a different profile (Silent and Vibrate disable PTT by default). You may also unsubscribe to all channels.

**To transmit on the priority channel:**

- 1 Press and release the **Talk** button.
- 2 Select the priority channel from the list.
- 3 Press and hold **Talk**, then speak.

**To end a PTT broadcast:**

- Press the **End** key to exit the PTT broadcast.

**To change the PTT volume:**

- Press the up/down volume buttons on the side of the handset while receiving a PTT broadcast.

## **PTT Configuration**

You can configure PTT to a different default channel, you can allow PTT broadcasts to override an active call, and you can subscribe or unsubscribe to channels that the system administrator has enabled.

### **Accept While Busy**

The Accept While Busy option allows PTT calls to come in as active calls (if enabled) or as calls on hold (if disabled).

If enabled, a PTT broadcast will interrupt telephone calls and you will be able to hear the audio of both the telephone call and the PTT broadcast on the same audio selection. The party on the other end of the telephone call cannot hear the PTT broadcast unless that party has also enabled Accept While Busy.

If disabled, PTT broadcasts are placed on hold during an active call and in order to hear the broadcast, you must select the PTT call and press the Resume soft key.

**To refuse or accept all PTT broadcasts while on a telephone call:**

- 1 Navigate to **Settings > Basic Settings > Preferences > Paging/PTT Configuration**.
- 2 Select **Accept While Busy**.
- 3 Enable or disable as desired.

## Polycom SpectraLink 8400 Series Wireless Handset

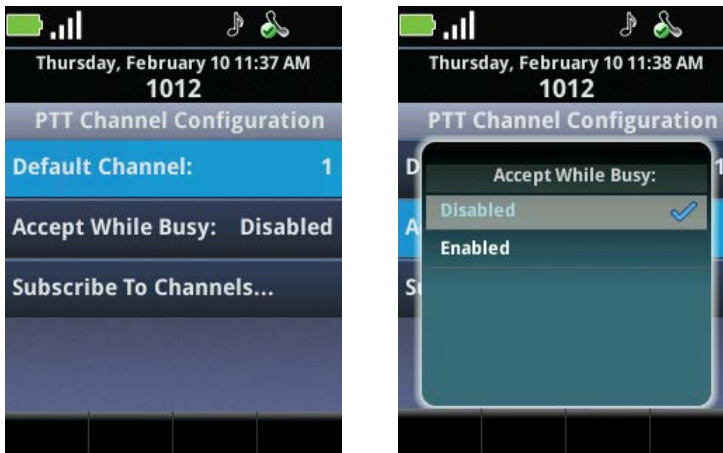

### Subscribe to Channels

You can subscribe to any channel that has been enabled by the system administrator and displays on your list of channels.

#### To subscribe to additional PTT channels:

- 1 Navigate to **Settings > User Settings > Preferences > Paging/PTT Configuration**.
- 2 Select **Subscribed Channels**.
- 3 Select the channels you want to add and enable them.
- 4 Press the **Home** key to exit.
- 5 Confirm the selections by selecting the **Save Config** option.

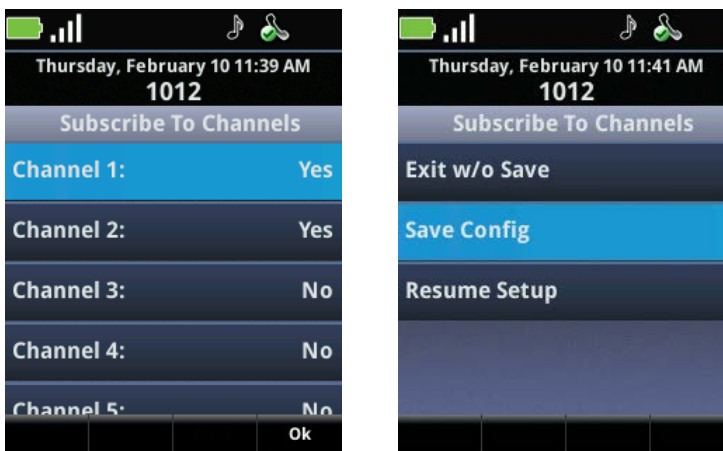



## Setting PTT Alerts

PTT alerting is set within each profile. Navigate to **Settings > User Settings > Notification Profiles > [profile] > Alerting** and scroll to the PTT alerting options. To customize PTT alerts, see *Customizing a Profile*.

You may set different or identical PTT options for starting and ending transmissions with the PTT Start Transmission and PTT End Transmission options. You may customize tone, alert, and vibration for each mode.

### To set alert tone volume:

- Select **Tone Volume** and use the soft keys to adjust the slider.

### To set alert tone pattern:

- Select **Tone Pattern** and select the alert tone from the list of options.

### To enable vibration:

To enhance the alerting of a PTT broadcast, you may enable PTT vibrate. When you enable PTT vibrate, the handset will vibrate three times whenever a PTT broadcast is received, whether the handset is in standby or in a call. If in a call, the phone will issue the chirp alert. The vibration does not replace any PTT tone pattern already set.

Select **Vibrate** and select the vibrate option from the list.



To set the handset for PTT vibrate only, enable the vibrate option and set the alert tone pattern to Silent Ring.

## Paging Contacts

The Paging feature allows the handset to make a telephone call to a specified group of contacts as defined by the system administrator who can make several different groups available for paging. By default, subscriptions to groups 1, 24, and 25 are enabled. Contact your system administrator for information.

## Paging Groups

The following paging group types are available:

**Emergency pages** Every phone will receive this page and play it at the highest audio level. If a phone is active on a call using the speakerphone, the Emergency page will be heard on the speaker. If Do Not Disturb is enabled, the Emergency page will be heard on the speaker. The audio level will return to normal for the subsequent non-Emergency pages.

**Priority pages** Pages from this group are received by all phones unless Do Not Disturb is enabled or an Emergency page is already playing. Priority pages are played at the current audio level.

**Normal pages** For pages from these groups, the first page received is accepted; all others are ignored (not played and not stored). The administrator can provide a label for groups 1 to 23. The label identifies the type and can comprise up to 15 characters. The label for Group 1, ALL, is defined by default.

Note that groups 24 and 25 are reserved for Priority and Emergency pages respectively.

## Sending and Receiving a Page

At the start of a page, a repetitive set of alert messages is sent to ensure that receiving phones are ready to receive the page. When the page cell first displays, it will briefly show the word Preamble. The transmission can start after the preamble period.

### Sending a Page

You initiate pages by pressing the **Features** soft key and then selecting the **Paging** option, the paging group, and then pressing the **Page** soft key. A page displays as a call appearance, indicating the page sender and paging group. The audio signal continues until the sender or the user terminates the page. The page terminates for everyone in the group when the sender presses the End key. An individual can end the page on a single handset by pressing the End key.

#### To send a page:

- 1 To send a page, press the **Features > Paging** soft key.

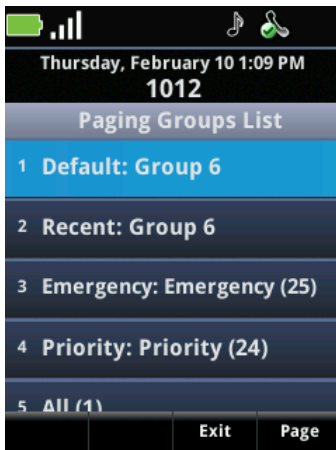

- 2 Select the group you wish to page.
- 3 Press the **Page** soft key to start the page.
- 4 Within seconds, the preamble period ends and the page starts. At this point, start speaking your message.



If you press the Start key while you are sending a page, the page ends and the Dialer opens.

#### Change the audio option while sending a page:

- Change the audio option while you are sending a page by pressing the **Speaker** soft key and selecting a different option.

#### Ending a page:

- Press the **End** key. If you are the sender, this ends the page for everyone. If you are the recipient, pressing the **End** key ends the page only for you.

#### Receiving Pages

How you receive a page can depend on: the priority of the page being sent, whether you are on an active call, whether you have enabled your phone to receive pages during an active call.

You will receive pages on the paging groups you are subscribed to as well as group 24 (Priority pages) and group 25 (Emergency pages). If you enable Do Not Disturb, you will receive only Emergency pages.

### **Receiving pages when you are not in an active call:**

If you receive a page and you are not in an active call, the page displays on your screen no matter what the paging group is. You can do the following:

- Hold the page and resume a held page.
- End the page. Press the **End** key to stop receiving the page. This ends the page at your phone only.
- Place a new call by opening the dialer.

### **Receiving a page during an active call:**

How you handle a page when you are in an active call depends on the page priority and if you have enabled your phone to receive pages when in an active call. If it is a Priority or Emergency page, the page will display in a second call appearance as an active call. You will hear both the original call and the page audio. Press the **End** key to end the page.

### **If the page is not a Priority or Emergency page:**

- If you have enabled your phone to receive pages while in an active call, the page will display in a second call displayance as an active page. You will hear both the original call and the page through the selected speaker option. Press the **End** key to end the page.
- If you have disabled your phone from receiving pages while you are in an active call, the page will display in a second call displayance as a held page. You can select the page by scrolling to it and pressing the **Resume** soft key. Press the **End** key to end the page

## **Paging Configuration**

You can change the default paging group, configure whether to accept or reject pages while in an active call, and subscribe/unsubscribe to paging groups.

### **Default Paging Group**

The default paging group is set by the system administrator. By default, pages are sent and received on Group 1. You can change the default group.

### **To change the default paging group:**

- 1** Navigate to **Settings > User Settings > Preferences > Paging/PTT Configuration**.
- 2** Select **Paging**. The Paging Groups List opens and the default group is highlighted.
- 3** Press the **Ok** key.
- 4** Type the number of the new default group.
- 5** Press the **Ok** soft key.

## Paging Group Subscriptions

In order to receive a page from a particular group, you must subscribe to that group. By default, you are subscribed to groups 1, 24, and 25. Contact your system administrator for information about who is in each group.

### Change the group subscriptions:

By default, you are subscribed to paging groups 1, 24, and 25. You can change which groups you are subscribed to, as can your system administrator. You cannot disable your subscriptions to groups 24 and 25.

- 1 Navigate to **Settings > User Settings > Preferences > Paging/PTT Configuration > Paging**.
- 2 Scroll down to **Subscribe to Groups**, and then press **OK**.
- 3 Scroll to the group you want to subscribe to.
- 4 Press **OK**.
- 5 Select **Yes**.
- 6 Press the **Back** key and confirm the changes.

### Allow/disallow pages to play during active calls:

By default, if you are in active call when a page is received, the page will be held until you end the active call (an Emergency page is heard immediately). You can change the configuration to accept pages while you are in an active call and have the page audible during the call.

- 1 Navigate to **Settings > User Settings > Preferences > Paging/PTT Configuration > Paging**.
- 2 Scroll down to **Accept while Busy**, and then press **OK**.
- 3 Highlight the option you want (**Yes** or **No**) and press **OK**.
- 4 Press the **Save** soft key to save the change.

### Adjust the volume of non-Emergency group pages:

- Use the side buttons to adjust the volume during a non-Emergency group page.



You cannot adjust the volume of Emergency group pages using the handset volume control buttons. Setting the Emergency page volume is an administrator function. By default, Emergency pages are played at a very high volume level.

### **Change Where Pages are Played**

An incoming page is always played on the handset's speakerphone unless you are in an active call or wearing a headset, in which case the page is played through the handset or headset respectively.

# Chapter 6: How to Use the Contact Directory

---

The Contact Directory allows you to store a large number of contacts; contacts can be dialed, searched, added, edited, and deleted.

When you open the Contact Directory, contact are listed alphabetically by last name, and the View, IM, Search, and Edit soft keys display.

You may add contacts manually, from the missed, received, and placed call lists, or from the IM History list. You may also add contacts from the Corporate Directory. See *Searching and Saving with the Corporate Directory*.

## Contact Directory Fields

The following table describes the fields you can configure for each contact in your contact directory.

**Table 3: Contact Directory Fields**

Field Name	Description
<b>First Name</b> <b>Last Name</b>	Names are sorted alphabetically by first name and can be searched for by either first or last name. They display in the contact list by label, first name, last name. Each field supports a maximum of 32 characters.
<b>Contact</b>	Enter the phone number. This could be an extension number within your facility, or an IP address or phone number outside your facility. The phone number must be unique, and must not already exist in the directory. If you try to save an entry with a number already in use, the entry will not be saved. This field supports a maximum of 128 characters.
<b>Speed Dial Index</b>	<p>The Speed Dial Index number is automatically assigned to the next available index number. You may edit it after the contact has been added.</p> <p>When editing the Speed dial index number, you may assign it an unused value between 1 and 9999. If you assign it a value that is already in use, the message <b>Speed dial index already exists</b> displays. If you enter an invalid speed dial index number (for example, 0 or 00), the message <b>Speed dial index is invalid</b> displays.</p>

---

Field Name	Description
<b>Label</b>	A label further identifies the contact and is displayed before the name. This field supports a maximum of 32 characters.
<b>Ring type</b>	Choose a ring identifier from the drop-down list to specify a unique ring tone for this contact.
<b>Divert Contact</b>	If you want calls from this contact to be sent to another party, enter that party's number here. This field supports a maximum of 32 characters.
<b>Auto Reject</b>	If you enable Auto Reject, the calls from this contact will not ring on your handset. Your system administrator determines how rejected calls are handled (for example, rejected calls may go to your voicemail system). Calls that are rejected from a contact display in the Missed Calls list.
<b>Auto Divert</b>	If you set the Auto Divert field to enabled, each time the contact calls, the call will be directed to a third party specified in the Divert Contact field.
<b>IM Name</b>	Enter an IM identifier for this contact. See the <i>Understanding IM Contact Names</i> section for additional information about the entry requirements for this field.

---

## Managing Your Contacts

This section explains how to add, search, edit, and delete contacts, and how to reject and divert calls.

### To add contacts manually:

- 1 Navigate to the **Contacts/Call Lists > Contact Directory** and press **OK**.

Any contacts in the directory will display in alphabetical order by last name. A list of contacts that you have already entered displays. If you have created instant messaging (IM) contacts, each contact shows a presence icon indicating their IM status. See **Chapter 7: Instant Messaging** for more information about Instant Messages.



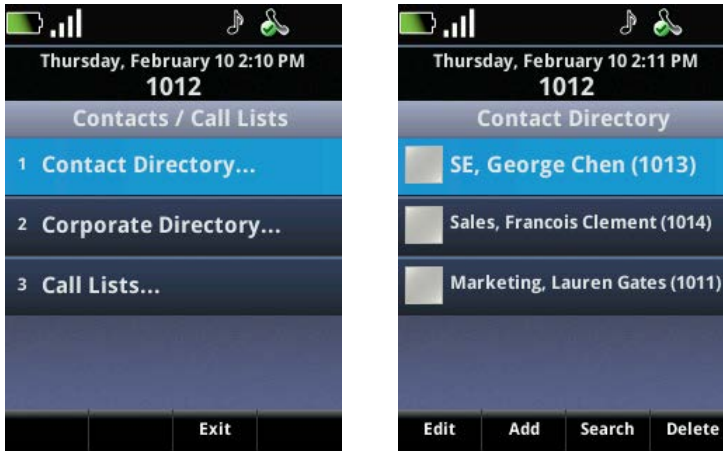

- 2 Press the **Add** soft key. A blank Add to Contact Directory screen displays:

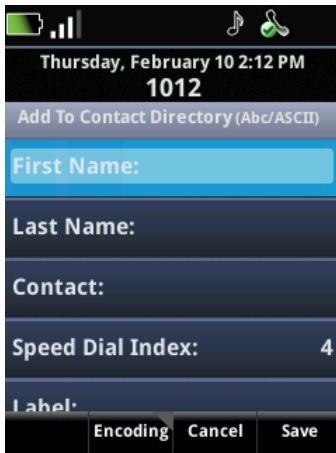

- 3 Add contact information about the new contact. Use the soft keys for entry assistance.
- 4 When finished, press the **Save** soft key.
- 5 Press the **Home** key to return to the Home screen.

**To add a contact from the Missed, Received or Placed Call Directory:**

- 1 Navigate to the **Contacts/Call Lists > Call Lists** and press **OK**. See *Using Call Lists* for more information.
- 2 Highlight the contact and press the **Info** soft key. Information about the call displays on the screen.
- 3 Press the **Save** soft key. The contact information is entered in the Contact Directory.  
You will need to edit the entry with any information not picked up by the save process to complete the contact directory entry.

- 4 Press the **Home** key to return to the Home screen.

**To search for a directory contact:**

- 1 Open the **Contact Directory**.
- 2 Press the **Search** soft key, enter the first few characters of the contact's first or last name, and press the **Search** soft key again.
- 3 Continue to use the **Search** soft key and enter characters until you find the contact.

**To edit directory contacts:**

- 1 Open the **Contact Directory** and search for the entry you wish to edit.
- 2 Press the **Edit** soft key to open the Edit Contact screen.
- 3 Use the navigation keys to position the insertion point. Use the << soft key to erase left. Enter the new information and press **Save**.

**To delete a directory contact:**

- 1 Open the **Contact Directory** as above and search for the entry you wish to edit.
- 2 Highlight the name you wish to delete and press the **Delete** soft key.

**To reject calls from a contact:**

- Follow the directions for editing a contact and enable the Auto Reject option.

**To divert calls from a Contact to another party:**

- 1 Follow the directions for editing a contact.
- 2 Enter the number you want to divert calls to in the **Divert number** field.
- 3 Scroll down and enable the **Auto Divert** option.

## Using Call Lists

The handset captures information about calls you have missed, received, and placed. Missed Calls, Received Calls, and Placed Call lists enable you to view call details, save the contact information to the Contact Directory, delete calls, and call an entry on the list.

**To open a call list:**

- 1 Navigate to **Contacts/Call Lists > Call Lists** and press **OK**. The call list opens.
- 2 Press the Type soft key to specify which type of call you wish to view.



- 3 Scroll to the type of call and select it by pressing **OK**.
- 4 Press the **Back** key to return to the Call list which now displays the selected type of call.

**To view call details:**

- Select the call you wish to view and press the **Info** soft key to view contact, time, name, and duration.



**To save contact information to the Contact Directory:**

- Select the call, press the **Info** soft key and proceed as you would for editing a contact.

**To delete calls from the Call List:**

- Open the list, select the call you would like to delete, and press the **Info** soft key. When the Details screen displays, press the **Delete** soft key.
- To delete the entire list, open the list and press the **Clear** soft key.

**To call an entry on the Call List:**

- Open the list and select the contact you would like to call and press the **Info** soft key. When the Details screen displays, press the **Dial** soft key.

## Searching and Saving with the Corporate Directory

Your system administrator may have enabled access to the Corporate Directory that resides on the call server used by the entire facility. You can search for contacts in the corporate directory, view their contact information, call them, and add them to your contact directory.

### Searching the Corporate Directory

Corporate directory contacts are usually sorted by last name. When you select the Corporate Directory option, the list displays and a search box opens.

**To search for a contact in the Corporate Directory:**

You can perform a quick search or an advanced search. A quick search allows you to search using the contact's last name (if the directory is alphabetized by last name) or first name (if the directory is alphabetized by first name). An advanced search will search using any combination of the contact's first and last name, phone number, address, and title.

- 1** Navigate to the **Contacts/Call Lists > Corporate Directory** and press **OK**.
- 2** Do one of the following:
  - a** To perform a quick search, enter the first few characters of the contact's last name, and then press the **Submit** soft key. The screen displays a list of contacts, starting with any successful matches.
  - b** To perform an advanced search, press the **AdvFind** soft key. From the Advanced Find screen, enter your search criteria, and then press the **Submit** soft key. The screen displays any successful matches.
- 3** To erase your search criteria and enter new criteria, press the **Clear** soft key.

### Saving Corporate Directory Search Results

You can enable your handset to save Corporate Directory search results, and to remember the last person you viewed in the directory. Whenever you re-display the Corporate Directory, the results of your last search, or the last person you selected, will display. If you don't enable your handset to save search results, each time you access Corporate Directory, a blank search screen will display.

**To enable your phone to save Corporate Directory search results:**

- 1** Navigate to **Settings > User Settings > Preferences > Corporate Directory > View Persistency**.
- 2** Scroll to **Enabled**, and then press **OK**.
- 3** Press the **Home** key.

# Chapter 7: Instant Messaging

---

Your system administrator sets up Instant Messaging (IM) using Microsoft Office Communications. If available, the IM status option will display on the Profiles soft key menu and you will be able to set up your own IM status, and enter an IM name for each of your contacts. See *Understanding IM Contact Names* for detailed information about setting this up.

You can initiate IM chats from the Dialer, from the Contact Directory, or from the IM history list. Only one IM session can be active at a time. An incoming IM chat opens a pop-up window. Active chats display in the Session Manager. You may hold or resume an IM session for five minutes after which the session is closed.

IM history is stored under **Messages > Instant Messages** by contact. Any received or sent chats are stored under that contact's name in the history list where you can view, delete, or initiate a new chat.

## Understanding IM Contact Names

The IM contact name is actually a shortened form of the IM address that the server recognizes in the form of [sip:ImUserName@CompanyServerDomain](#). When an ImUserName is, for instance, Joe54, and Joe is also in your company, you can enter Joe54 in the IM name field and the rest of the information is appended to the IM name when the chat is initiated. When a contact is added from the Corporate Directory or from the IM history list, you will see the full IM address saved in the IM Name field. You do not have to enter the domain name when you and your IM contact have the same domain name. Otherwise, if your IM contact doesn't share your domain name, include his or her domain name in the user name in the form of [sip:ImUserName@OtherDomain](#). The sip: prefix is not required, as it will be added by the handset if it is missing. In the Contact Directory, the fields for Last Name, Contact, and IM Name are required for IM communication.

The easiest way to get IM names is by adding contacts from the Corporate Directory or from the IM history list. Contacts that are added from the Corporate Directory may also have an IM name as part of their information. The required fields are automatically populated when a contact is saved from the IM history list, which presumes that the contact placed an IM chat with you first and therefore already has an IM name. See **Chapter 6: How to Use the Contact Directory** for more information about entering and editing data in the contact fields.



The easiest way to get IM names is from the Corporate Directory. See *Searching and Saving with the Corporate Directory* for more information.



Instant Messaging conferences are not supported. If another party sends you an invitation to an Instant Messaging Conference, the invitation will be rejected without notice to you as the party being invited.

## Understanding IM Status Icons

When a contact has an IM name, the IM icon will display to the left of the name in the Directory to indicate availability.

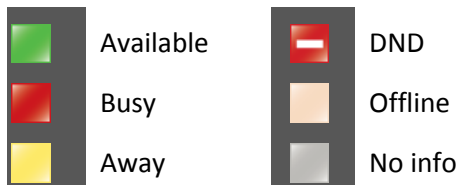

### Unread IM icon

If there is an unread IM from a contact, the unread message icon will display next to the contact name in the history list:



### To set your IM status:

When you are using IM, you need to set your status so that your IM contacts know your availability. Navigate to **Home > Profiles > My Status** and select the status you wish to display.

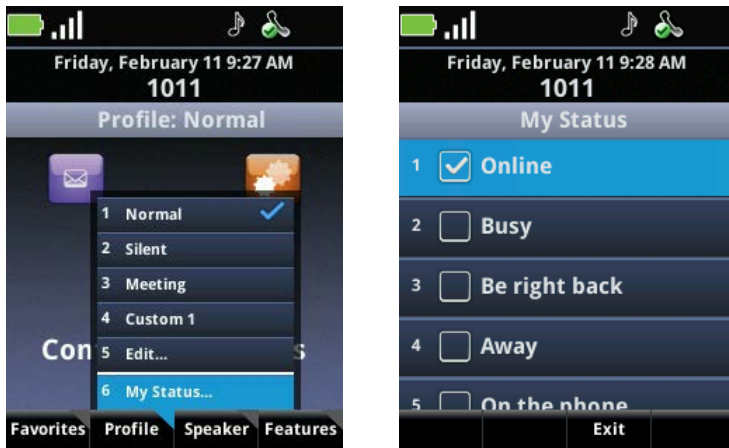

## Initiating an Instant Messaging Session

This section shows you how to initiate an instant messaging session, understand the chat window, manage instant message sessions, and read and manage stored messages.

You can initiate an instant message in several ways:

### Dialer:

- Open the Dialer as described in *How to Use the Dialer*. As you enter numbers or letters, the list filters contacts accordingly and displays both a telephony cell and an IM cell when a contact has an IM name. Select the IM cell and press **Start** to open a chat window.
- Press the **Dial Mode** soft key, select the **IM** option, and start entering the IM name. The Dialer filters contacts with IM names. Select the contact from this list to open a chat window.
- To start an IM chat with a name that is not in any of the lists, select the **IM Name** mode and enter the IM Name (username, or username@domain, or [sip:username@domain](#)) into the Dialer. Press **Start** to open the chat window.

### Message Center:

- Navigate to **Messages > Instant Messages** to open a list of contacts with recent chats. Select the contact you wish to open a chat with and press **OK** or **Start** to open a chat window for that contact.

### An incoming IM call:

- Accept the call by pressing **OK** or **Start**.

### Contact Directory:

- Open the Contact Directory and select a contact. Press the **Instant Msg** soft key to open a new chat window.



## Understanding the Chat Window

The IM chat window is divided into two sections. The top section contains the history of chats with the contact and the bottom section is the text entry field for your new message. Navigate within the history field by pressing the ▲ and ▼ keys. Navigate within the text entry field by pressing the ◀ and ▶ keys. Press the << soft key to erase backwards when you want to edit text you have entered.

When a new IM chat window opens, the cursor is in the text entry field, ready for your new message. The default entry mode is alphabetic. Use the **Entry Mode** soft key for entering numbers and other characters. Use the **Quick Notes** soft key to enter preprogrammed messages. A message can be up to 128 characters in length. Once you have entered the message, press **OK** to send.



## Managing Instant Message Sessions

An IM pop-up window displays an incoming IM chat.



**To ignore an IM call:**

- Press the **Ignore** soft key to close the IM pop-up. The IM session is added to the session list in the hold state and this IM chat session is added to the IM History list as an unread entry.

**To end an IM call without responding:**

- Press the **End** key to close the IM pop-up and add the IM session to the IM history list for that user as an unread entry. The IM session is not placed on hold and will not display in the Session Manager.

**To allow an IM pop-up to expire:**

- If you take no action during an IM pop-up announcement, the pop-up announcement will terminate after 20 seconds and the alerting IM session will display in the Session Manager as a held session.

**To end an IM session:**

Press the **End** key.

- When you terminate the IM chat by pressing the **End** key while the IM chat window is active, the IM chat window closes, and the session is stored in the IM history List.
- When you terminate the IM chat by pressing the **End** key while the IM chat cell is highlighted and on hold or alerting, the cell is closed and the chat is stored in the IM history List.

**To exit an IM session without ending it:**

Do one of the following:

- Press the **Home** key to place the chat on hold in the Session Manager and display the Home screen.
- Press the **Back** key to place the chat on hold and display the Session Manager. If you entered the IM chat from the IM history list, the IM history list will display, not the Session Manager.
- Press the **Start** key to place the chat on hold in the Session Manager and display the Dialer.

**To open an IM chat window during an existing non-IM call:**

- Open the Dialer to locate the IM contact. Press the **OK** key to put any existing non-IM call on hold and open an IM Chat window.



Only one IM Chat can be active at any given time. If you have a chat on hold in the Session Manager and use the Dialer to start a new IM chat session, the old session will be terminated. Any unfinished user entry will be discarded and the session will be appended to the IM History. A new chat window will open for the new chat.



An incoming IM message that arrives while another chat is active is announced by a tone. It will be appended to the IM History List as an unread message and the unread count status icon is incremented.

## Reading and Managing Stored Messages

IM history is stored under Messages > Instant Messages by contact. The History list displays a list of contacts you have had IM sessions with since the last time the handset was turned on, starting with the most recent.



When you turn your handset off, the IM history list is cleared. Only IM chats that you have made during the current handset power cycle are displayed in the IM history list.

### To view IM chat history:

- Highlight the cell of the contact you wish to view and press **OK**. An IM chat window opens with the top window displaying all chats with that contact since the handset was turned on.

### To resume an IM session:

- Highlight the cell of the contact you wish to chat with and press **OK**. An IM chat window opens.

### To delete IM contact history:

- To delete an IM contact history from the IM history list, highlight the contact's cell and press the **Delete** soft key.

### To add an IM contact to the Contact Directory:

You may receive IM chats from people who are not in your Contact Directory. You can add these people to the Contact Directory from the IM history list.

- 1 Highlight the contact and press the **Add Contact** soft key to open the Contact Directory entry screen. Certain fields are populated.
- 2 Enter additional contact information in the blank fields. See **Chapter 6: How to Use the Contact Directory**.

# Chapter 8: Using the Calendar

---

At the time of this writing, this feature remains under development. Some of the information presented here may not be accurate in the current beta release. Refer to the updated online documentation following the initial beta release date.

The Calendar is an optional feature set up by the system administrator as part of an implementation of the Exchange Server Integration (ESI). Administrators may not implement the Exchange server in your facility in which case the Calendar will not be listed under the Applications icon.

The Calendar implementation displays the day view by default. The month view identifies days with appointments by a yellow dot on the day. You can select and view appointment details from the day view and call appointment contacts.

The clock time and date are configurable in the Settings menu.



You must be logged in to use the Calendar application.

Open the Calendar from the Home menu by selecting the **Application** icon and scrolling to the **Calendar** option.

## Day View



Scroll to view times that are not visible on the screen.

Use the Previous and Next soft keys to scroll to other days. Use the Month soft key to display the Month view.

## Month View

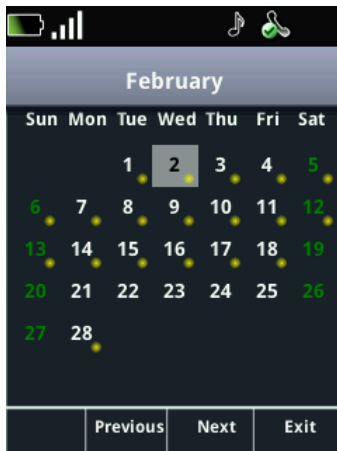

Yellow bullets indicate appointments on the bulleted day.

Use the navigation keys to navigate to the day and press the OK key to open the Day view for that day.

Use the Previous and Next soft keys to scroll to other months. Use the Exit soft key to return to the Home screen.

## Details View

When you are in the Day view, you can open a Details view for each appointment displayed.

The Details View lists meeting information:

- Meeting name/Subject
- Meeting Date
- Meeting Start Time
- Meeting End Time
- Meeting Location
- Meeting Organizer Name
- Required Attendees
- Meeting body description (agenda)

Scroll to view the entire meeting details.

## Polycom SpectraLink 8400 Series Wireless Handset

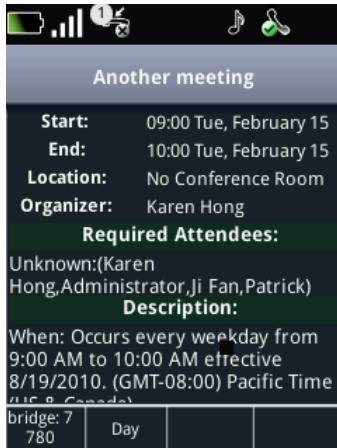

Use the Day soft key to return to the Day view. Press the leftmost soft key to connect to the conference bridge and join or begin the conference.

### Meeting Attendees

When you join a meeting, attendees display in a meeting window.

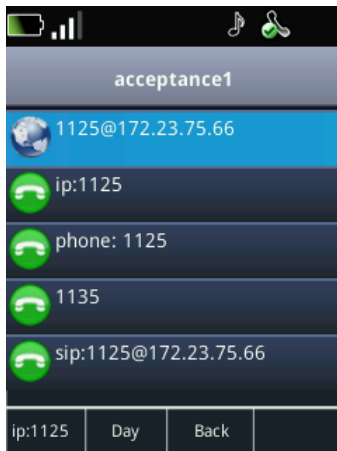

The Back soft key will return you to the meeting details screen. The Day soft key will return you to the Day view.

### Notification Pop-up

If meeting notification is enabled, a pop-up, shown next, will display 15 minutes before the scheduled meeting start time:

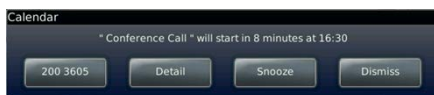

You can take one of these actions when the pop-up displays:

- **Action** Primary action related to the event, could be a phone number, or HTTP URL
- **Details** Open the event detail
- **Snooze** Remind the user later
- **Dismiss** Cancel the reminder

### **Session Sensitive Calendar**

The calendar application is session sensitive. If you have a meeting scheduled with an active call contact, and that meeting was set up by invitation, you can display the meeting details by launching the calendar during the call.

# Chapter 9: Using the Barcode Reader (8450 only)

---

At the time of this writing, this feature remains under development. Some of the information presented here may not be accurate in the current beta release. Refer to the updated online documentation following the initial beta release date.

The SpectraLink 8450 Wireless Telephone is equipped with a barcode scanner located at the top rear of the handset. This feature reads GS1-standard, UPC barcodes printed on the covers of most products worldwide to associate a product with its detailed description, including price.

You activate the barcode scanner by pressing the scanner button on the right side of the handset. The phone supports two types of applications—one-to-one and many-to-many.

## General Operating Instructions

The barcode scanner, shown next, is at the top rear of the handset. Scanning range is 4-12 inches.

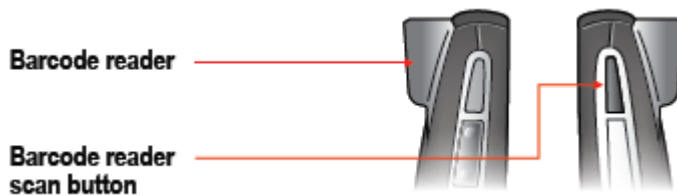

### Scanning with the barcode reader:

- 1 Hold the handset so that the rear of the handset is facing the item you want to scan.
- 2 Press the scan button. The red light comes on. Orient the red light so that it shines across the barcode. The red light stays on for as long as you press the button and accomplish a complete scan.

A beep sounds to indicate a successful scan and the red light turns off. See the **Appendix C: User Settings Menu** for help in navigating to sound settings for this option.

- 3 Release the scan button.



## Using the One-to-one Application

You can use the one-to-one application when one handset is programmed to enter information into fields in an application on a single computer or on a Web-based application. When you are connected to a PC via a Wi-Fi network connection, the one-to-one application emulates keyboard input by using the handset as a barcode reader. When using a computer, you must use the barcode reader in close enough proximity to the computer so you can see that the cursor is in the field you want to enter information to.

The system administrator programs this application and can provide you with additional information about how the application works.

### To associate the handset with the computer:

This step does not apply to applications that reside on the handset. If you are using an application that resides on the handset, proceed directly to opening the application.

- 1 Point to the hot spot corner of the monitor (as configured locally) to display the barcode association window.



- 2 Scan the barcode. This associates the handset with this computer. A warble sounds, a connected balloon pops up, and the association status is displayed in the computer's system tray. The green arrow signifies a current connection between the handset and the computer. A corresponding status icon will display on the handset.



The barcode association status will disconnect if you do not scan a barcode within a time period defined locally by the system administrator. Open the application immediately after associating the handset to avoid disconnection.

**To open the application:**

- The application may reside on the handset or on a PC.
- 1** If the application resides on the handset, navigate to **Applications > [application name]**. If the application resides on a PC, open the application as directed by your system administrator.

Ensure that the cursor is in the correct entry field. Use the computer keyboard to move it as needed.

- 2** Point to the barcode you want to scan and press the scan button as described above. View the data entered to verify it is correct.

The cursor may automatically tab to the next field if the system administrator has configured this option. In some cases, you may have to manually tab to the next field or move the cursor to the desired field. Consult with your system administrator for information about how to move the cursor to the next field if this is not immediately obvious.

## Using the Many-to-Many Application

The many-to-many application enables you to use any handset in a group to enter information into many computers. The system administrator programs this application and can provide you with additional information about how it works in your facility.

As with any barcode reader, the handset provides keyboard entry function; the barcode scan button scans into fields on your computer that are controlled by the application.

Follow the steps outlined in the previous section to associate the handset with the computer and open the application. You can connect only one computer at a time. If you try to connect to another computer while connected to the first one, you will disconnect the first computer. If a new handset tries to connect to a computer while you are still connected, it will disconnect you and connect the new handset.

Open the application on the computer and follow the procedure as directed by the system administrator.

# Chapter 10: Applications

---

The Applications icon, which is available from the Home screen, may be populated with Web applications or other types of applications that are customized for your facility. See your system administrator if you expect to have a custom application, or if you see this message: “No configured applications please see your system administrator.”

## How to Use the Handset While in a Web Application

Certain applications enable you to access and navigate the Web, and to enter information into fields using the keypad. If installed, Web applications will be available through the Applications icon on the Home screen. Use the information below to navigate in a Web application. See your system administrator if you have any questions.

### Navigating the Web

Use the ▲ and ▼ navigation keys to scroll up and down.

Use the ◀ and ▶ navigation keys to tab through navigable fields.

### Entering Text

Use the ◀ and ▶ navigation keys to tab in and out of a text box. Once you start entering text, the ◀ and ▶ keys navigate within the text you are entering.

Use the Edit/Cancel soft key to return to the tab functions.

Use the OK key to confirm the text you have entered.

Use the soft keys to perform Web actions.

## Custom Applications

If programmed, certain custom applications use Open Application Interface (OAI) navigation icons.

A custom application call is identified in the display title with a row of icons just below.



	OAI arrows 'on'
	OAI arrows 'off'

Polycom SpectraLink 8400 Series Wireless Handset

	OAI line numbers 'on'
	OAI line numbers 'off'
	OAI Message Waiting 'on' and 'off'

Example screen:

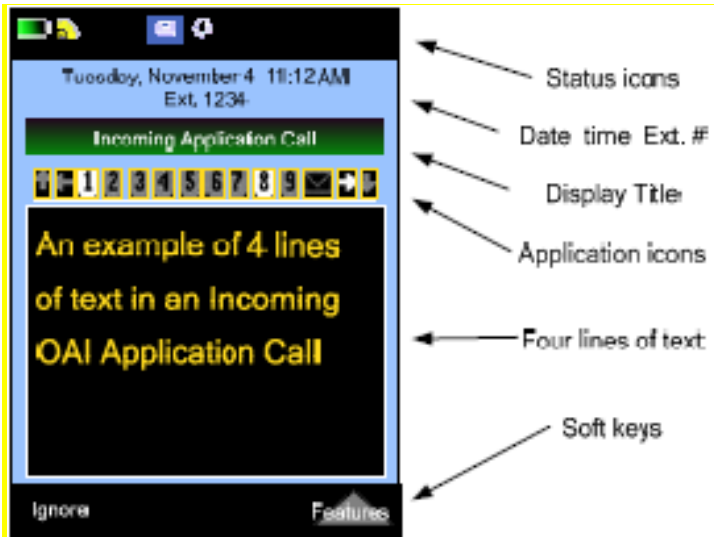

# Chapter 11: Customizing your Handset

Profiles generally dictate the type and volume of the handset rings, warnings, and other functions. Profiles are labeled Normal, Silent, Meeting, and Custom. Profiles have default settings that you can customize. You may also edit Profile labels.

## To set the current profile:

- Press the **Profile** soft key from the Home screen and select the desired Profile.

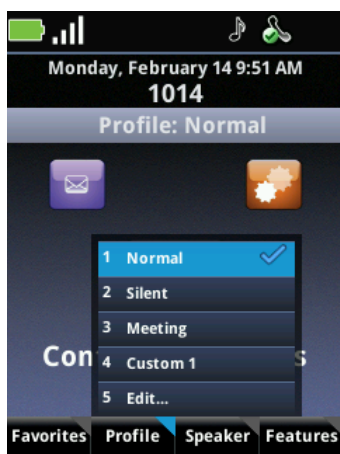

## To open profile settings:

- Navigate to **Settings > Basic Settings > Notification Profiles** or select the Edit option on the **Profiles** soft key menu.

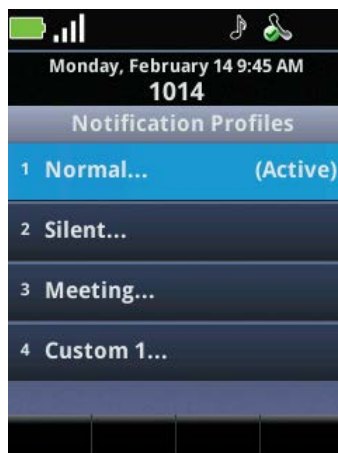
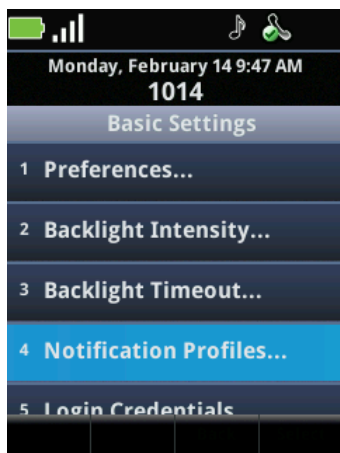

## Customizing a Profile

This section contains general information about customizing a Profile. For a complete list of Profile setting options, see **Appendix C: User Settings Menu**.

### Changing the Ring Settings for Telephone Calls

Select the profile you wish to edit and select the Ringing option. Note that the Tone Volume setting is on the same menu as the Ringing option. The Ringing option sets the ring and vibrate patterns, not the volume. Set the volume by selecting the Tone Volume option.

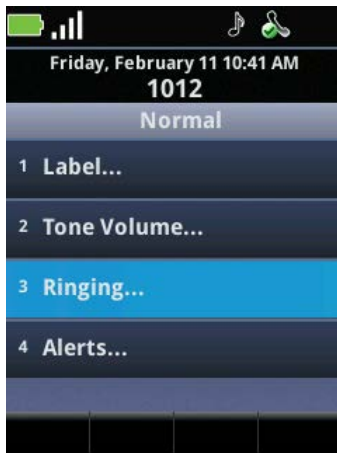

You may adjust the ring settings for different types of calls. You can set telephone calls to notify you with one type of ring, and you can set different message alerts for non-telephony applications through the OAI 1 and OAI 2 options.

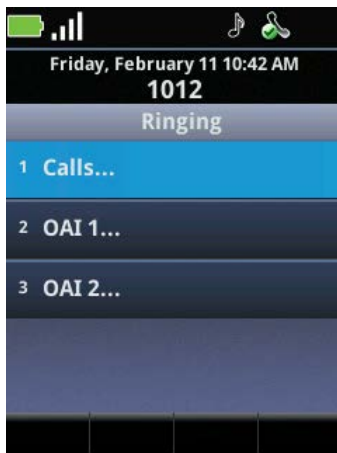

For telephony calls, you can adjust the ring pattern and the vibration pattern. Experiment with the options until you find a combination that suits you.



## Setting Unique Ring Tones for Contacts

When setting up or editing contacts in the Contact Directory, you can specify a ring type for each contact. See *Contact Directory Fields* and **Appendix C: User Settings Menu**.

## Change the Alerting Characteristics

Use the Alerting option to customize the alerting characteristics for each type of alert. Volume, tone pattern, and vibration options are available. See **Appendix C: User Settings Menu** for a complete list of alerts that you can customize.

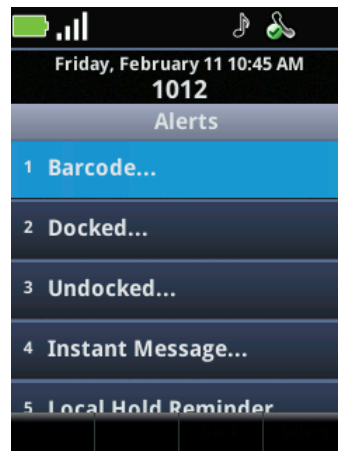
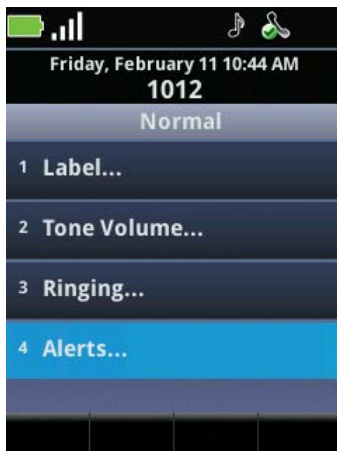

## Changing the Ring Settings for OAI Applications

Select the OAI application from the ringing menu and change the settings as for Calls. See **Appendix C: User Settings Menu** for additional information.



## Changing the Alerting Characteristics for PTT

You can change the alerting characteristics of PTT broadcast notifications. See *Change the Alerting Characteristics* and **Appendix C: User Settings Menu**.

## Customizing the Handset Display and Other Preferences

You can adjust the text that displays on the screen through the Preferences menu. Each of the options listed next are available from the Preferences menu.

### To open the Preferences menu:

- From the Home screen, navigate to **Settings > User Settings > Preferences**. Scroll to view all the options.

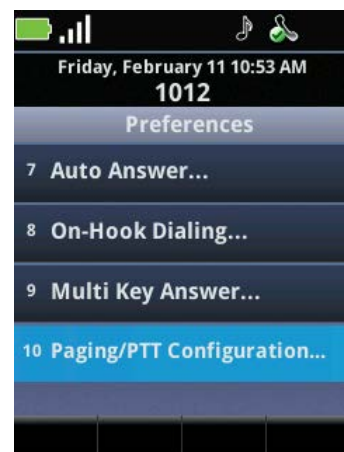
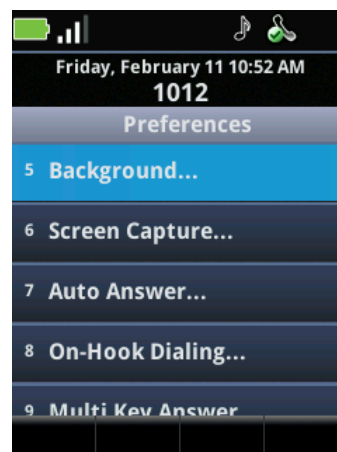
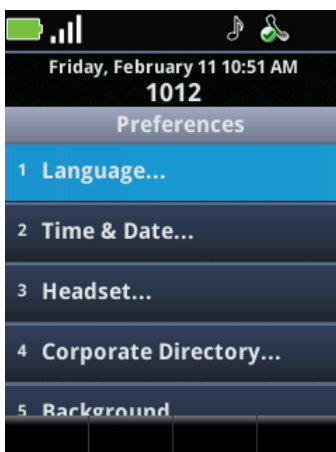



## Language

The Language option allows you to change the language of menu options and other text that displays on the handset.

## Time & Date

Select the Time and Date option on the Preference menu to get to the Time and Date screen. You can choose the Clock Date, Clock Time, Clock Order, or you can disable/enable the time and date display.

## Headset Memory

The Headset Memory option enables the handset to remember that it has a headset plugged into it. You may enable or disable this option. If you enable it, you do not need to select the Headset option from the Speaker soft key menu every time you plug in a headset. Enable this option if you use a headset most of the time.

## Corporate Directory

You use the Corporate Directory option when you want to display entries in the corporate directory chronologically instead of alphabetically. See *Searching and Saving with the Corporate Directory*.

## Background

The Background option enables you to change the background characteristics of the display. Options are customized by facility.

## Screen Capture

Not available. This is a development and documentation utility.

## Auto Answer

When the handset is in the Auto Answer Mode, an incoming call will be answered automatically after the first ring. When you select this option, you are given the option to auto answer SIP calls and mute the microphone for auto answered calls.

## On-Hook Dialing

With the On-Hook dialing option, you can enable or disable the ability to dial a call before getting a dial tone, also called pre-dialing. If disabled, you must press **Start** before dialing a number.

## Multi Key Answer

The Multi Key Answer option enables you to answer incoming calls by pressing any keypad key. It is disabled by default. See *Multi Key Answer Feature* for more information.

## Paging/PTT Configuration

You can configure PTT to a different default channel, you can allow PTT broadcasts to override an active call, and you can subscribe or unsubscribe to channels that the system administrator has enabled. For more information on configuring PTT, see **Chapter 5: Push-to-Talk (PTT) and Paging**.

## Adjusting the Backlight

You can make backlight adjustments on the Basic Settings menu. From the Home screen, navigate to **Settings > User Settings**. Scroll to view the options.

### Backlight timeout

The backlight LCD turns on when you press any key or when incoming activity occurs, and will turn off after a selected period of either 5, 10, 15, or 30 seconds of inactivity. You can also disable the backlight completely with this option.

#### To change the backlight timeout:

- From **Settings > User Settings**, select **Backlight Timeout** to change the amount of time that elapses after a period of inactivity before the backlight turns off or to disable it completely.

### Backlight Intensity

You can adjust the backlight for different lighting conditions.

#### To change the backlight intensity:

- From **Settings > User Settings**, select **Backlight Intensity** on the Preferences menu to get to the Backlight Intensity screen. Here you can adjust the Backlight On intensity, the Backlight Idle intensity, and the Maximum Intensity.



When you modify the Maximum Intensity, you are modifying the entire Backlight intensity scale. For example, if you decrease the Maximum Intensity, the low, medium, and high values for both Backlight On intensity and the Backlight Idle intensity decrease.

# Chapter 12: Charging Your Handset

---

The Battery Pack in your handset is removable. You may charge the Battery Pack either while removed from or while attached to your handset. Some facilities provide chargers to all users while others maintain a bin of charged Battery Packs. Ask your system administrator about how your facility provides chargers if you were not issued one with your handset.

## Charging the Battery Pack

You must fully charge your handset's Battery Pack before you use it for the first time. Depending on the type of charger you use, this might take several hours.



Only use SpectraLink 8400 Series Battery Packs with SpectraLink 8400 Wireless Telephones. Check the label on the Battery Pack and ensure the model number is RS657 for the Standard Capacity Battery Pack or RS658 for the Extended Capacity Battery Pack.



**Risk of electric shock. Do not expose charger or battery to liquid, vapor, or rain.**

The Battery Pack icon at the right side of the status bar of your handset is completely green when it is fully charged. When the handset is in a charging device and charging, the Battery Pack icon has a lightning bolt symbol through it. When the background of this icon turns green, the Battery Pack is fully charged.

 Fully Charged Battery Pack, handset not in charger

 Battery Pack charging, handset in charger

 Battery Pack fully charged, handset in charger

## Charger Options

This section shows you three ways to charge your handset's Battery Pack: Quad charger, USB Charger, and Dual Charger.



Only use SpectraLink 8400 Series Chargers with SpectraLink 8400 Wireless Telephones. Check the label on the Charger and ensure the model number shown on the label is the same number this document gives for the Charger models.

## Quad Charger

The Quad Charger (DCA40), shown next, is designed to charge four Battery Packs simultaneously. You can mount it on a horizontal or vertical surface.



The Battery Pack snaps into the charging slot. The LED on the occupied bay indicates the charging status of the Battery Pack in the bay.

**Table 4: Quad Charger LED Indications**

LED Indication	Quad Charger LED
Blinking	Charging
Solid green	Fully charged
Off	Not properly seated or empty

## USB Charger

The USB charger (SA106B-05), shown next, plugs into the USB port on the side of the handset; the transformer plugs into a 110v outlet. Charging status is indicated on the handset's status bar.



## Dual Charger

The Dual Charger (DCA39), shown next, is designed to charge the Battery Pack in the handset while it remains operational and to charge an additional Battery Pack in the rear charging bay. The handset has charging priority when both slots are occupied. The handset's charging status is indicated by the battery status icon. When the handset is fully charged or removed, the Battery Pack will begin charging.

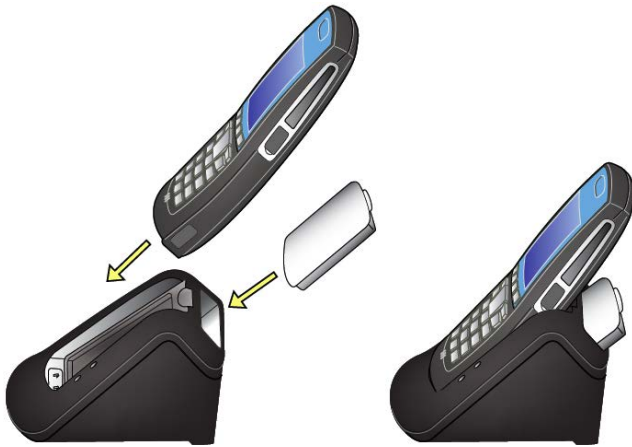

- Place the handset in the front slot, facing forward. The Battery Pack snaps into the charging bay as in the illustration shown next.

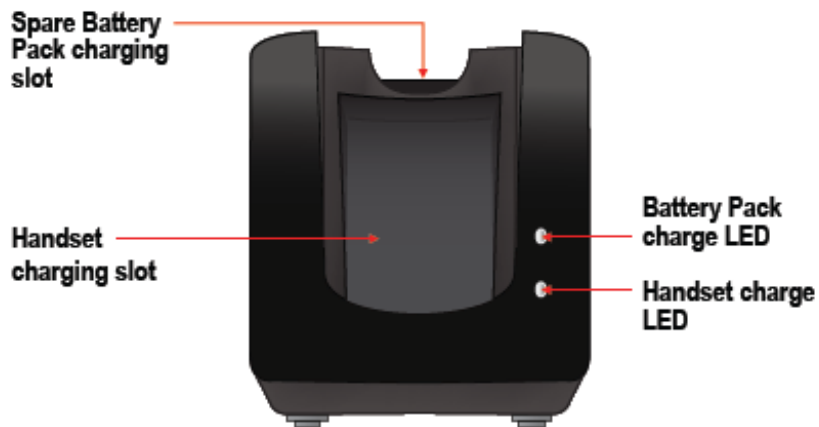

The top LED indicates the status of the Battery Pack in the rear bay. The bottom LED indicates whether or not the handset is properly seated. The Battery Pack icon on the handset indicates its charging status. LED status indicators are listed in Table 4: LED Charge Indicators, shown next.

**Table 5: Dual Charger LED Indicators.**

LED Indication	Battery Pack LED	Handset LED
Blinking	Charging	n/a
Solid green	Fully charged	Properly seated
Off	Not properly seated or empty	Not properly seated or empty



For fastest charge, do not use the handset slot of the Dual Charger for handset storage when you are trying to charge a Battery Pack in the rear slot as it will interrupt the charging cycle and take longer for the Battery Pack to charge.

## About Battery Packs

Two Battery Pack models are available: Standard and Extended. The Standard lithium ion rechargeable handset Battery Pack gives you approximately eight hours of talk time or 80 hours of standby time. Standby time occurs when you turn on the handset, but not in an active call. Charging times vary according to the type of charger you are using.

Type	Talk Time	Standby Time	Charging Time*
Standard (RS657)	8 hours	80 hours	3.5 hours typical*
Extended (RS658)	12 hours	120 hours	5 hours typical*

\* Using the Quad Charger



The type of Battery Pack is printed on the label. Remove the Battery Pack and view the label to determine the type of Battery Pack you have been issued.



The length of time to charge is dependent on the method used—Quad Charger is the fastest. If you are using the handset while it is in the charger, charging time will be prolonged.



**WARNING: THERE IS A RISK OF EXPLOSION IF YOU REPLACE THE BATTERY PACK WITH AN INCORRECT TYPE. ONLY USE POLYCOM MODEL RS657 OR RS658 BATTERY PACKS WITH SPECTRALINK 8400 SERIES WIRELESS TELEPHONES. DISPOSE OF USED BATTERIES ACCORDING TO THE INSTRUCTIONS.**

### Indications of Low Battery

Periodically, you will have to recharge the Battery Pack. The Battery Pack icon on the handset display's status row indicates the amount of charge remaining.

The handset will sound warning tones and display the Battery Low message when there are fewer than two minutes of talk time remaining. When the handset is in Standby mode, the message Battery Low and a series of chirps indicate a critically low Battery Pack charge. The handset will not work until the Battery Pack is charged.



All batteries can cause property damage and/or bodily injury, such as burns, if a conductive material such as jewelry, keys, or beaded chains touches exposed terminals. The conductive material may complete an electrical circuit (short circuit) and become quite hot. Exercise care in handling any charged battery, particularly when placing it inside a pocket, purse, or other container with metal objects.



**WARNING— The battery used in this device may present a risk of fire or chemical burn if mistreated. Do not disassemble, heat above 45°C, or incinerate. Replace battery with Polycom model RS657 or RS658 only. Use of another battery may present a risk of fire or explosion.**

## Battery Pack Removal and Replacement

To remove, press up on the Battery Pack removal latch on the back of the handset. The Battery Pack releases outward.

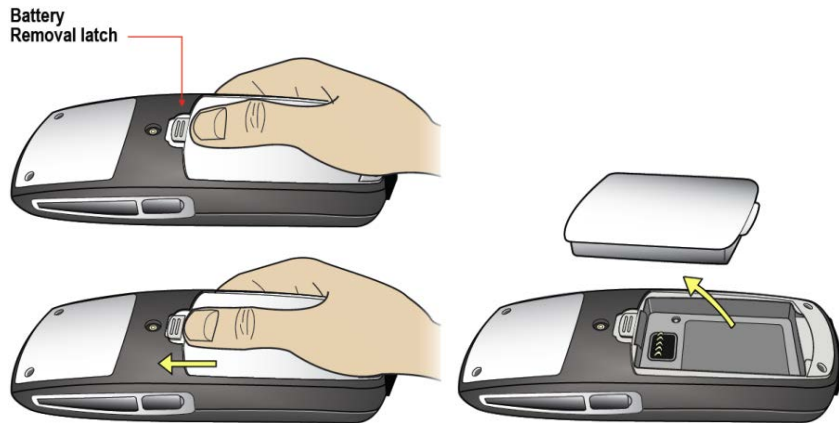

To replace, slide the tab of the Battery Pack into the bottom slot as shown below. Gently push the top of the Battery Pack until it snaps into place. You should not have to force it against the handset.

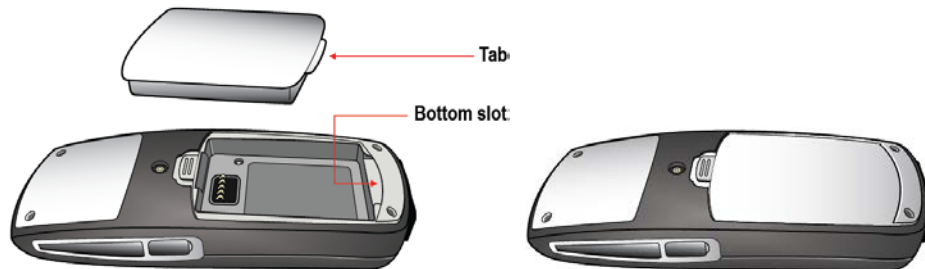

## Notes on Battery Packs

- Battery Pack life will vary depending on your handset's model and its features and system infrastructure.
- Ensure that you fully charge the Battery Pack the first few times, as the Battery Pack becomes most efficient after the first few charge cycles.
- If multiple Battery Packs are supplied with your handset, Polycom recommends that each be fully charged upon receipt to prolong battery life. Battery Packs will slowly lose charge if unused. To maintain battery potential, charge unused Battery Packs occasionally or alternate Battery Pack use.
- After a length of time, Battery Packs will lose the ability to maintain a charge and to perform at maximum capacity and will need to be replaced. This is normal for all batteries.
- If your Battery Pack requires replacement, contact your system administrator.
- Overnight charging is best done while the handset is turned off.



## Charging Your Handset

- If the handset does not charge, clean the Battery Pack, the charger, and the handset contacts with an alcohol swab.
- When the handset is properly seated, the backlight comes on briefly and the handset beeps to indicate that charging has begun.
- Any battery that exhibits swelling, cracking, or other abnormality should be disposed of promptly and properly.
- Dispose of any used battery promptly. Keep away from children. Do not disassemble and do not dispose of in fire.
- The handset is not designed for and will not function properly with third party batteries.

# Appendix A: Troubleshooting

---

Information for this Appendix is to be determined.

# Appendix B: Cleaning and Drying the Handset

---



The SpectraLink 8000 Series Wireless Telephones have been tested for resistance to cleaning chemicals per IEC 60068-2-74 (1999). Exposure of the 8440/8450 handsets to Lysol® or diluted bleach poses little risk of functional or cosmetic damage.

- Avoid dropping the handset or knocking it against hard surfaces. Carry the handset in a holster or carrying case to protect it.
- There are no serviceable parts in the handset or chargers. You should not open the handset case nor disassemble the chargers. Doing so will void your warranty.
- Turn off the handset and unplug the chargers before you clean them. Never immerse the handset or charger in liquid. Clean the exterior surfaces, including the charging contacts, with a cloth that has been slightly moistened with water. Take care not to exert undue pressure on charger electrical contacts while wiping.
- Polycom recommends the use of a silicone cover to prolong the life of your handset, especially when it is dropped regularly or cleaned frequently with the disinfectants prescribed below.
- Wiping the handset surface with a water-dampened cloth or paper towel will remove most films or residues. If the soiling is too stubborn for plain water, a mild detergent solution, Lysol, isopropyl alcohol, or diluted bleach may be used.
- Pre-treated cloths and toiettes, like those used for eyeglasses or cameras, may be used to clean the handset; however, avoid using those containing lanolin or aloe as these will leave a slippery residue.
- When cleaning with disinfectants, do not rub the keypad characters vigorously. Doing so will degrade the handset's keys and make them illegible.
- Do not directly spray or immerse the phone in a disinfectant or cleaning agent. Spray the disinfectant on a soft cloth or paper towel, then wipe the phone's surface to dry it.
- The following products should NOT be used on the SpectraLink wireless telephones:

- Do not use cleaning products containing quaternary ammonium compounds,<sup>1</sup> such as CaviWipes™, CaviWipes™ XL, Cavicide® or Sani-Wipes®, Sani-Cloth, Super Sani-Cloth® and Sani-Cloth® Plus. Quaternary ammonium compounds have been laboratory tested and proven to damage the handset plastics.
- Do not use furniture polishes, waxes, or plasticizer-based cleaners (ArmorAll®, etc.)
- Do not use lanolin, aloe, glycerin, or other skin care products
- Do not apply any solvent such as acetone, mineral spirits, etc.
- Should the headset connector become dirty, you may experience a scratchy or intermittent signal. To clean the connector, dip the non-padded end of either a wooden or paper handled cotton swab in isopropyl alcohol. Gently insert in the connector and twist, repeating several times. If available, blow compressed air into the connector to clear debris.
- Keep the headset jack covered when not in use.
- Using a carrying case may help protect the surfaces and help prevent liquids (rain, etc.) from entering into the interior of the handset. This product is not waterproof, and exposing the unit to liquids may result in permanent damage to the unit.
- If your wireless telephone interior gets wet, do not try to accelerate drying with the use of an oven or a dryer as this will damage the wireless telephone and void the warranty. Instead, do the following:
  - 1 Immediately power off the wireless telephone.
  - 2 Remove Battery Pack from wireless telephone.
  - 3 Shake excess liquid from the wireless telephone.
  - 4 Place the wireless telephone and Battery Pack in an area that is at room temperature and has good airflow.
  - 5 Let the wireless telephone and Battery Pack dry for 72 hours before reconnecting the Battery Pack and/or powering on the wireless telephone.

If the wireless telephone does not work after following the steps listed above, contact your dealer for servicing information.

---

<sup>1</sup> Quaternary ammonium compounds are also known as C12-18-alkyl [(ethylphenyl) methyl] dimethyl, chlorides and Benzyl-C12-18-alkyldimethyl ammonium chlorides. Review the Materials Safety Data Sheet for your specific product to verify the chemical composition.

# Appendix C: User Settings Menu

The User Settings menu contains all the options you need to customize your handset settings for optimum use. Navigate to this menu from the Home screen Settings icon. Use the tables shown next as a quick reference to find the option you need.

## Settings > Basic Settings

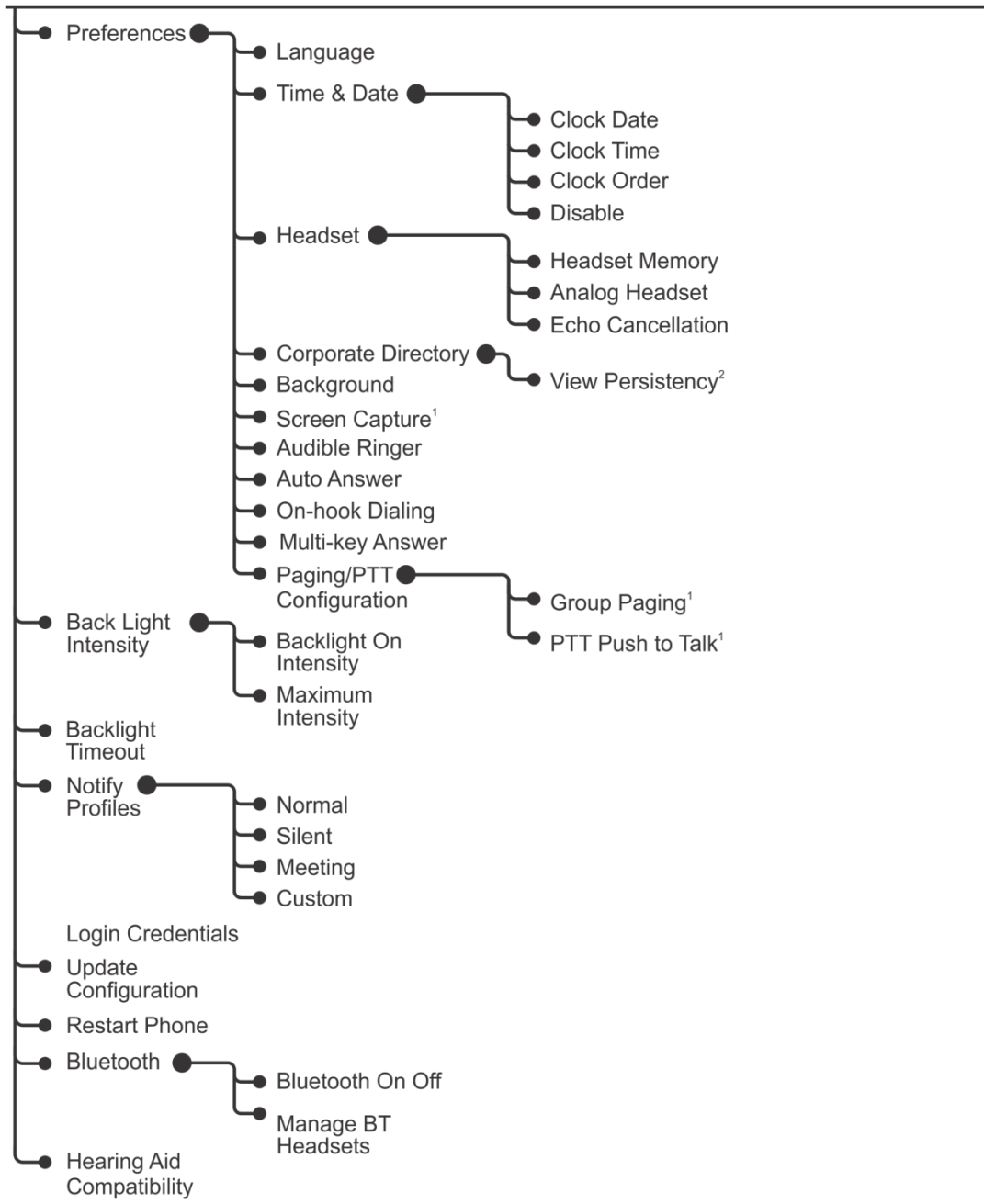

<sup>1</sup> If enabled.

<sup>2</sup> If enabled and license available.

## Settings > Advanced Settings<sup>3</sup>

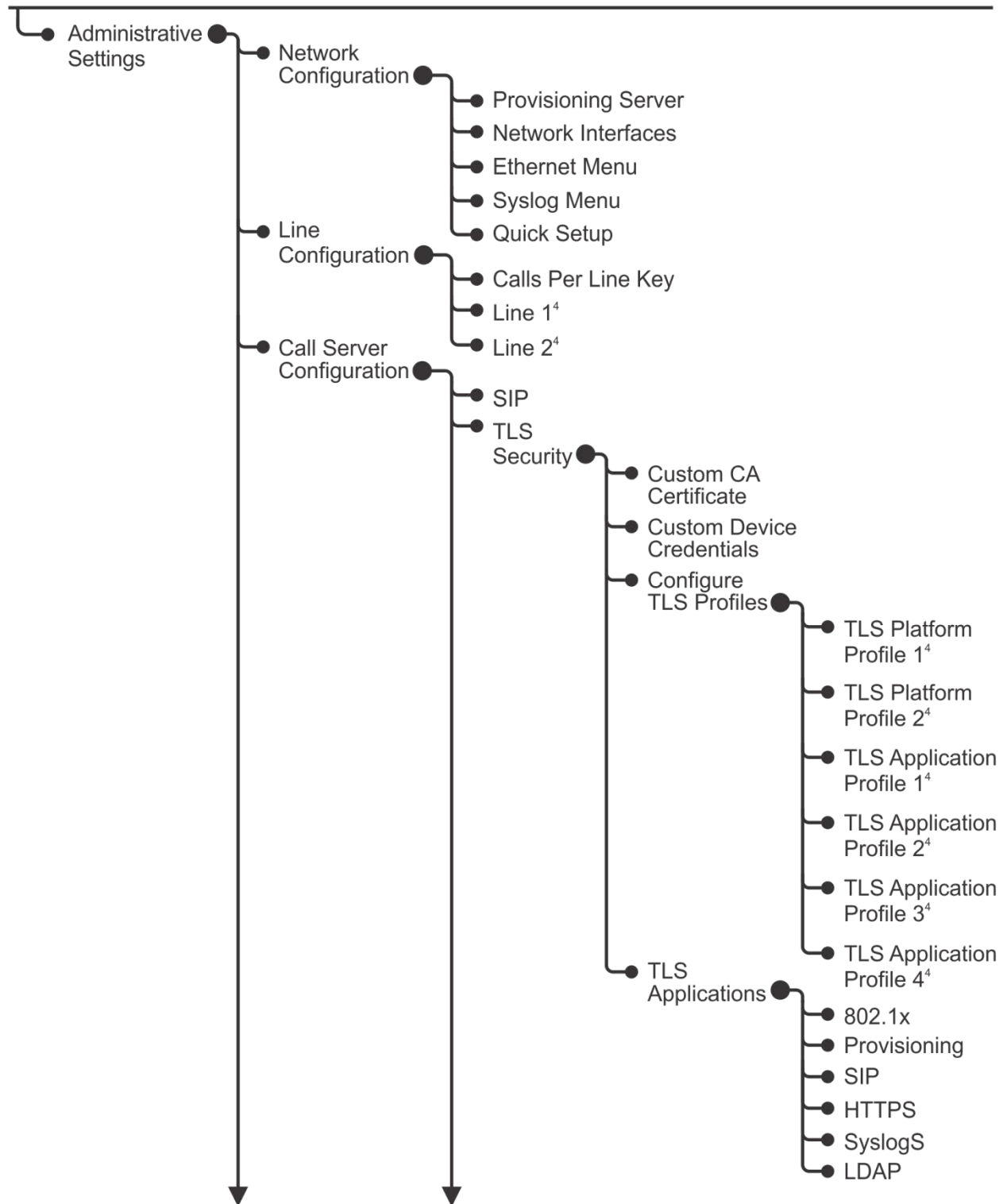

<sup>3</sup> Requires administrator password.

<sup>4</sup> If applicable.

## Settings > Advanced Settings<sup>1</sup> (Continued)

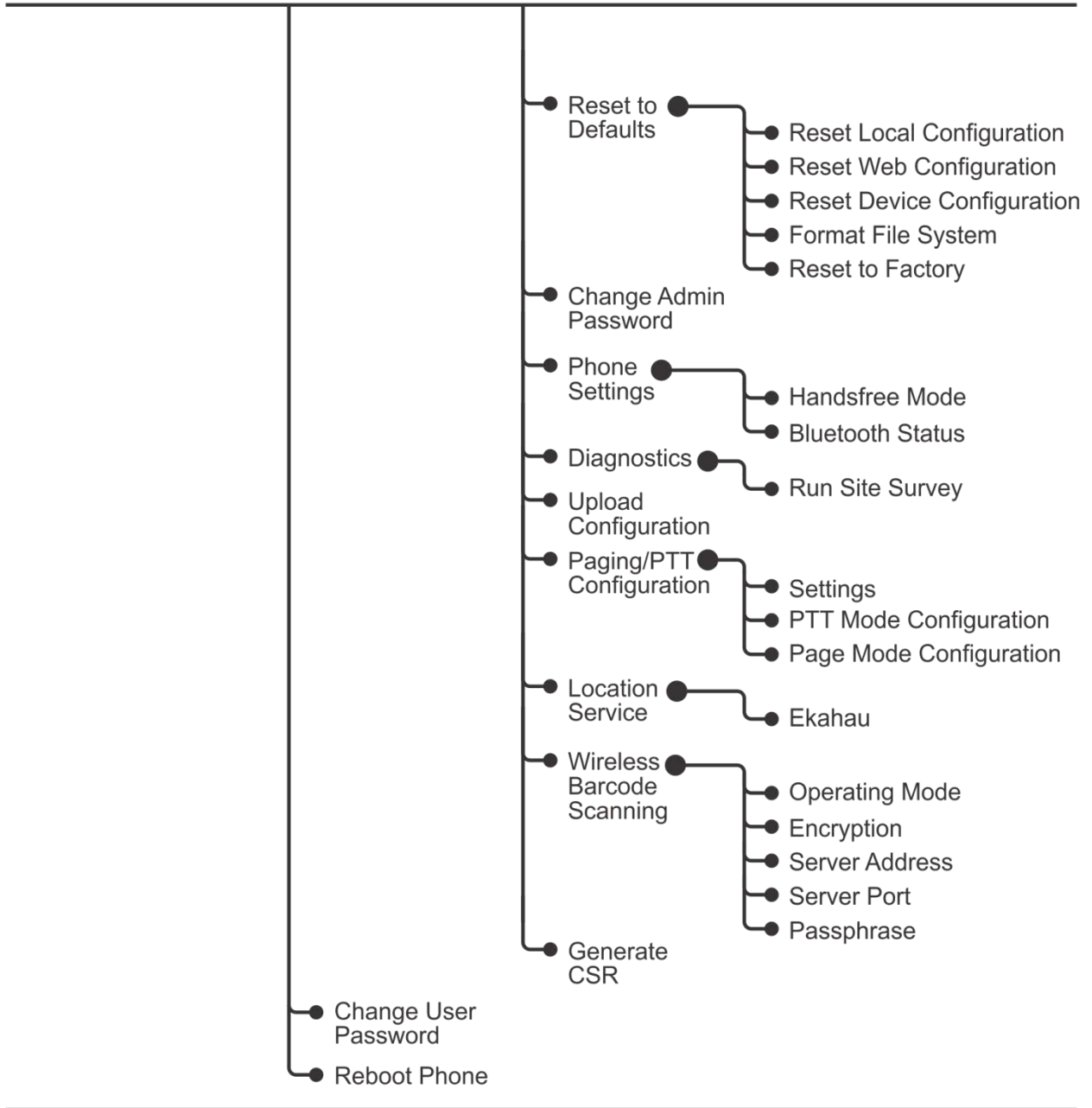

## Settings > Feature Settings

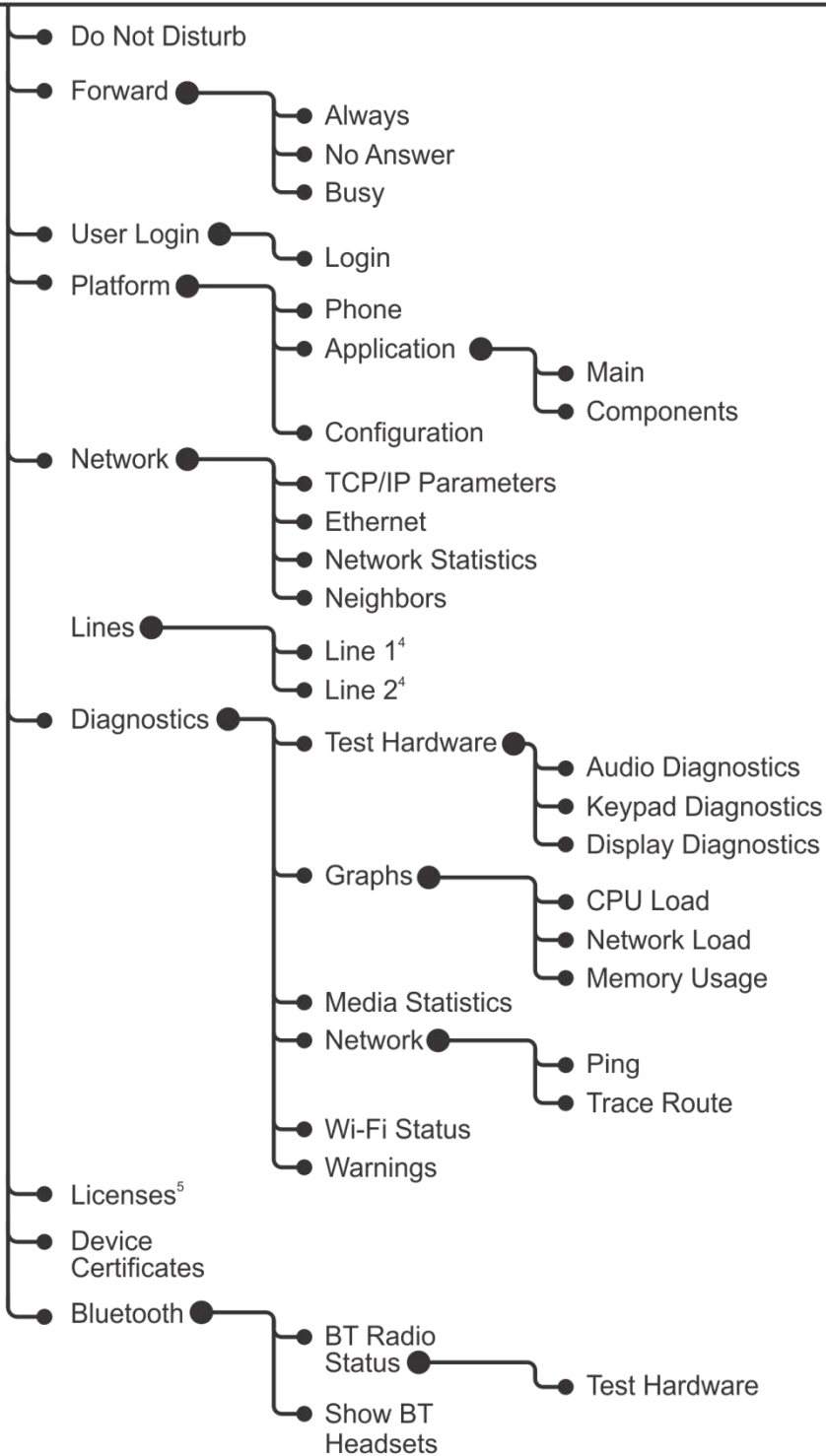

<sup>4</sup> If applicable.

<sup>5</sup> If licenses available.



## Directories<sup>6</sup>

---

- Contact Directory
- Corporate<sup>7</sup> Directory
- Missed Calls
- Received Calls
- Placed Calls
- Clear ●
  - Language
  - Time & Date

## Messages<sup>6</sup>

---

## Applications<sup>6</sup>

---

<sup>6</sup> Organization dependent.

<sup>7</sup> If enabled and license available.

# Appendix D: Icon Table

---

A table of icons and their associated meaning is under development.

# Appendix E: Safety Information



Each SpectraLink family of products only works with other members of the same family. If you have any questions about product compatibility, contact your system administrator.

## **SpectraLink 8400 Series**

Use only 8400 Series products with other 8400 Series products as identified by the model number located on the label of the product.

SpectraLink 8450 Wireless Telephone	8450
SpectraLink 8440 Wireless Telephone	8440
Speakerphone Dock	8410
USB Charger	SA106B-05
Dual Charger	DCA39
Quad Charger	DCA40
Standard Capacity Battery Pack	RS657
Extended Capacity Battery Pack	RS658

## **SpectraLink 8000 Series**

Use only 8000 Series products with other 8000 Series products as identified by the model number located on the label of the product.

SpectraLink 8020 Wireless Telephone	802X
SpectraLink 8030 Wireless Telephone	803X
Desktop Charger	PCS1850
Dual Charger	PCD1850
Quad Charger	PCQ1850
Standard Battery Pack	PBP0850
Extended Battery Pack	PBP1300
UltraExtended Battery Pack	PBP1850

## Industry Canada Notice

Under Industry Canada regulations, this radio transmitter may only operate an antenna approved by Industry Canada. To reduce potential radio interference between signaling coverage areas, you should choose an antenna that does not emit more power than the equivalent isotropically radiated power (EIRP).

This device complies with Industry Canada license-exempt RSS standard(s). Operation is subject to the following two conditions: (1) this device may not cause interference, and (2) this device must accept any interference, including interference that may cause undesired operation of the device.

## Chargers and Battery Packs

- Chargers operate in a 50° to 85° F (10° to 30° C) environment. Do not expose them to freezing temperatures or direct sunlight.
- Do not place anything in the charger other than the handset or single Battery Pack as appropriate to avoid bending the contacts. Bent contacts can keep the Battery Pack from charging.
- Only use SpectraLink 8400 Series Battery Packs with SpectraLink 8400 Series Chargers.
- Never use a non-SpectraLink charging unit as it could damage the Battery Pack.
- Use only the original plug-in power adapter for the chargers.
- Contact your service representative for assistance if you have a faulty Battery Pack or a problem with your charger.
- Any battery that exhibits swelling, cracking or other abnormality should be disposed of promptly and properly.



Do not immerse the Battery Pack in water or throw it into a fire.



Do not throw away the Battery Pack with your domestic waste. Take used Battery Packs to an appropriate collection point for recycling or send them back to your supplier or servicing agent.



All batteries can cause property damage and/or bodily injury, such as burns, if a conductive material such as jewelry, keys, or beaded chains touches exposed terminals. The conductive material may complete an electrical circuit (short circuit) and become quite hot. Exercise care in handling any charged battery, particularly when placing it inside a pocket, purse, or other container with metal objects.

## Wireless Telephones

Please read the following text carefully for important safety information.



The earpiece may retain magnetic objects.



Changes or modifications to this equipment that are not approved by Polycom may cause this equipment to fail to comply with part 15 of the FCC rules, voiding the user's authority to operate this equipment.



Polycom products contain no user-serviceable parts inside. Refer servicing to qualified service personnel.



Polycom recommends that standard acceptance procedures be followed prior to operating this equipment in proximity of life-support systems.

## Operational Warnings

Certain operational environments are potentially hazardous. Please read the following text carefully to ensure that you understand the phone's operating conditions.

### Potentially Explosive Atmospheres

Do not take your handset into any area with a potentially explosive atmosphere. Do not remove, install, or charge batteries in such areas. Sparks in a potentially explosive atmosphere can cause an explosion or fire resulting in bodily injury or even death.



Avoid areas with potentially explosive atmospheres include fueling areas such as lower decks on boats, fuel, or chemical transfer or storage facilities, areas where the air contains chemicals or particles such as grain, dust, or metal powders, and any other area where you would normally be advised to turn off your vehicle engine. Areas with potentially explosive atmospheres are often marked with signs, but not always.

## Electromagnetic Interference and Compatibility

Nearly every electronic device is susceptible to electromagnetic interference (EMI) if inadequately shielded, designed, or otherwise configured for electromagnetic compatibility.

### Facilities

To avoid electromagnetic interference and/or compatibility conflicts, turn off your handset in any facility where posted notices instruct you to do so. Hospitals or health care facilities may be using equipment that is sensitive to external radio frequency (RF) energy.

### Pacemakers

The Health Industry Manufacturers Association recommends that you maintain a minimum separation of 6 inches (15 cm) between a handheld, wireless-radio product and a pacemaker. These recommendations are consistent with the independent research by, and recommendations of, Wireless Technology Research. Persons with pacemakers should:

- ALWAYS keep the handset more than 6 inches (15 cm) from their pacemaker when the handset is turned on
- Not carry the handset in a breast pocket
- Use the ear opposite the pacemaker to minimize the potential for interference
- Turn the handset off immediately if you have any reason to suspect that interference is taking place

### Other Medical Devices

If you use any other personal medical device, consult the manufacturer of your device to determine if it is adequately shielded from external RF energy. Your physician may be able to assist you in obtaining this information.

## Use While Driving

Campus installations and warehouse facilities that use vehicles such as forklifts or golf carts should abide by these guidelines when using wireless telephones:

- Give full attention to driving and to the road, aisle, or path
- Use hands-free operation, if available
- Pull off the road, aisle, or path and park before making or answering a call

### **For Vehicles Equipped with an Airbag**

Do not place a portable device in the area over the airbag or in the airbag deployment area. An airbag inflates with great force. If you place the handset in the airbag deployment area, and the airbag inflates, the airbag may propel the handset at high speed and cause serious injury to occupants of the vehicle.

### **FCC Statement**

This device complies with part 15 of the FCC Rules. Operation is subject to the following two conditions: (1) This device may not cause harmful interference, and (2) this device must accept any interference received, including interference that may cause undesired operation.

## **Specific Absorption Rate (SAR) Information for SpectraLink 8400 Series Wireless Telephones**

Your wireless telephone is a low power radio transmitter and receiver. When it is on, it receives and sends out radio frequency (RF) signals. In August 1996, the Federal Communications Commission (FCC) adopted radio frequency (RF) exposure guidelines with safety levels for hand-held wireless handsets. Those guidelines are consistent with the safety standards previously set by both U.S. and international standards bodies:

- ANSI C95.1 (1992) American National Standards Institute
- NCRP - Report 86 (1986) National Council on Radiation Protection and Measurements
- ICNIRP (1996) International Commission on Non-Ionizing Radiation Protection
- DHWC - Safety Code 6 Department of Health and Welfare Canada

These standards were developed by independent scientific organizations through periodic and thorough evaluation of scientific studies. The standards include a substantial safety margin designed to assure the safety of all persons, regardless of age and health. The exposure standard for wireless mobile handsets employs a unit of measurement known as the Specific Absorption Rate, or SAR. The SAR limit set by the FCC is 1.6W/kg.



In the United States and Canada, the SAR limit for mobile handsets used by the public is 1.6 watts/kg (W/kg) averaged over one gram of tissue. The standard incorporates a substantial margin of safety to give additional protection for the public and to account for any variations in measurements.

The FCC conducts tests for SAR using standard operating positions specified by the FCC with the handset transmitting at its highest certified power level in all tested frequency bands. Although the SAR is determined at the highest certified power level, the actual SAR level of the handset while operating can be well below the maximum value. This is because the handset is designed to operate at multiple power levels so that it uses only the power required to reach the network. Before a handset model is available for sale to the public, the FCC must test and certify it to ensure that phones do not exceed the limit established by the government-adopted requirement for safe exposure. The tests are performed in positions and locations (at the ear and worn on the body) as required by the FCC for each model. While there may be differences between the SAR levels of various handsets and at various positions, they all meet the government requirement for safe exposure.

The FCC has granted an Equipment Authorization for this model handset with all reported SAR levels evaluated in compliance with the FCC RF emission guidelines.

SAR information on this model handset is on file with the FCC. You can find it under the Display Grant section at <http://www.fcc.gov/oet/ea> after searching on the FCC ID number found on the handset label inside the battery compartment. Additional information on Specific Absorption Rates (SAR) can be found on the Cellular Telecommunications Industry Association (CTIA) Website at <http://www.ctia.org>.

**CE:**

0.060 W/kg Body Tissue

0.066 W/kg Head Tissue

**FCC:**

0.161 W/kg Body Tissue

0.203 W/kg Head Tissue

**Handset operation normal position**

To position the antenna properly, hold the handset as you would any other telephone, with the earpiece to your ear and speak into the microphone.



# Appendix F: End User License Agreement for Polycom Software

---

This End-User License Agreement (“Agreement”) is a legal agreement between you (either an individual or a single entity) and Polycom, B.V for the Polycom Software Product licensed by Polycom B.V in Europe, the Middle East, Africa, and Asia Pacific or Polycom, Inc., for the Polycom Software Product licensed by Polycom, Inc. in the rest of the world (collectively, “Polycom”). The Software Product includes the computer software included herewith and may include associated media, printed materials and online or electronic documentation (“Software Product”). By clicking ‘I agree’ or by installing, copying, or otherwise using the Software Product, you agree to be bound by the terms of this Agreement. If you do not agree to the terms of this Agreement, do not install or use the Software Product, and return it to your place of purchase for a full refund.

The Software Product is protected by copyright laws and international copyright treaties, as well as other intellectual property laws and treaties. The Software Product is licensed (not sold) to you, and its use is subject to the terms of this Agreement.

## 1. GRANT OF LICENSE.

Subject to the terms of this Agreement, Polycom grants to you a nonexclusive license to install and use the Software Product included with the Polycom product that incorporates or uses the Software Product (the “Product”). You may use the Software Product only in connection with the use of the Product. You are not permitted to lease, rent, distribute or sublicense the Software Product or to use the Software Product in a time-sharing arrangement or in any other unauthorized manner. Further, no license is granted to you in the human readable code of the Software Product (source code). Except as provided below, this License Agreement does not grant you any rights to patents, copyrights, trade secrets, trademarks, or any other rights in respect to the Software Product.

## 2. DESCRIPTION OF OTHER RIGHTS AND LIMITATIONS.

**2.1 Limitations on Reverse Engineering, Decompilation, and Disassembly.** You may not reverse engineer, decompile, or disassemble the Software Product, except and only to the extent that such activity is expressly permitted by applicable law notwithstanding this limitation. The Software Product is licensed as a single product. Its component parts may not be separated for use on more than one Product.

**2.2 Backup.** Except as expressly provided for under this Agreement, you may not copy the Software Product, except, however, you may keep one copy of the Software Product and, if applicable, one copy of any previous version for back-up purposes, only to be used in the event of failure of the original. All copies of the Software Product must be marked with the proprietary notices provided on the original Software Product. You may not reproduce the supporting documentation accompanying the Software Product.

**2.3 Modifications.** You may not modify, translate, or create derivative works of the Software Product.

**2.4 Proprietary Notices.** You may not remove or obscure any proprietary notices on or in the Software Product or the supporting documentation.

**2.5 Software Transfer.** You may permanently transfer all of your rights under this Agreement provided you retain no copies, you transfer all of the Software Product (including all component parts, the media, any printed materials, any upgrades, this Agreement, and, if applicable, the Certificate of Authenticity), and any recipient agrees to the terms of this Agreement. If the Software Product is an upgrade, any transfer must include all prior versions of the Software Product. However, if the Software Product is marked “Not for Resale” or “NFR,” you may not resell it or otherwise transfer it for value.

**2.6 Copyright.** All title and copyrights in and to the Software Product (including, but not limited to, any images, photographs, animations, video, audio, music, text, and “applets” incorporated into the Software Product), the accompanying printed materials, and any copies of the Software Product are owned by Polycom or its suppliers. The Software Product is protected by copyright laws and international treaty provisions. Title, ownership rights, and intellectual property rights in the Software Product shall remain in Polycom or its suppliers. Title and related rights in the content accessed through the Software Product is the property of such content owner and may be protected by applicable law. This Agreement gives you no rights in such content.

**2.7 Confidentiality.** The Software Product contains valuable proprietary information and trade secrets of Polycom and its suppliers and you shall protect the confidentiality of, and avoid disclosure and unauthorized use of, the Software Product.

**2.8 Dual-Media Software.** You may receive the Software Product in more than one medium. Regardless of the type or size of medium you receive, you may use only one medium that is appropriate for your single Product. You may not use or install the other medium on another Product.

**2.9 Reservation.** Polycom reserves all rights in the Software Product not expressly granted to you in this Agreement.

### **3. SUPPORT SERVICES.**

Polycom may provide you with support services related to the Software Product (“Support Services”). Use of Support Services is governed by the Polycom policies and programs described in the Polycom-provided materials. Any supplemental software code provided to you as part of the Support Services is considered part of the Software Product and is subject to the terms and conditions of this Agreement. With respect to technical information you provide to Polycom as part of the Support Services, Polycom may use such information for its business purposes, including for product support and development. Polycom will not utilize such technical information in a form that personally identifies you.

### **4. TERMINATION.**

Without prejudice to any other rights, Polycom may terminate this Agreement if you fail to comply with any of the terms and conditions of this Agreement. In such event, you must destroy all copies of the Software Product and all of its component parts. You may terminate this Agreement at any time by destroying the Software Product and all of its component parts.

### **5. UPGRADES.**

If the Software Product is labeled as an upgrade, you must be properly licensed to use the software identified by Polycom as being eligible for the upgrade in order to use the Software Product. A Software Product labeled as an upgrade replaces and/or supplements the software that formed the basis for your eligibility for the upgrade. You may use the resulting upgraded Software Product only in accordance with the terms of this Agreement. If the Software Product is an upgrade of a component of package of software programs that you licensed as a single product, the Software Product may be used and transferred only as part of that single Software Product package and may not be separated for use on more than one Product.

### **6. WARRANTY AND WARRANTY EXCLUSIONS.**

**6.1 Limited Warranty.** Polycom warrants that (a) the Software Product will perform substantially in accordance with the accompanying documentation for a period of ninety (90) from the date of receipt by you, and (b) any Support Services provided by Polycom shall be substantially as described in applicable written materials provided to you by Polycom, and Polycom support engineers will make commercially reasonable efforts to solve any problem issues. Polycom does not warrant that your use of the Software Product will be uninterrupted or error free, or that all defects in the Software Product will be corrected. Polycom’s sole obligation under this express warranty shall be, at Polycom’s option and expense, to refund the purchase price paid by you for any defective software product which is returned to Polycom with a copy of your receipt, or to replace any defective media with software which substantially conforms to applicable Polycom published specifications. Any replacement Software Product will be warranted for the remainder of the original warranty period or thirty (30) days, whichever is longer.

LIMITATION OF WARRANTY: Products purchased hereunder may include an Application Programming Interface, including, without limitation, the XHTML based API and the OAI API or any other API that may included in future software releases, which is resident on the Product and which enables external, third party control of the application-specific elements of the Product and provides third-party applications developers with tools for integration with the Product (the “API Software”). Polycom does not and cannot warrant that: (i) certain performance or results may be obtained using the API Software; (ii) the API Software is appropriate for Purchaser’s purposes or particular application; or (iii) the API Software is error or bug free of that it will provide uninterrupted usage. ACCORDINGLY, THE API SOFTWARE AND ITS DOCUMENTATION IS LICENSED "AS IS" WITHOUT ANY WARRANTY AS TO THEIR QUALITY, PERFORMANCE, MERCHANTABILITY OR FITNESS FOR ANY PARTICULAR PURPOSE. THE ENTIRE RISK AS TO THE RESULTS AND PERFORMANCE OF THE API SOFTWARE IS ASSUMED BY PURCHASER.

**6.2 Warranties Exclusive.** If this Software Product does not operate as warranted above, your sole remedy for breach of that warranty shall be repair, replacement, or refund of the purchase price paid, at Polycom's option. TO THE FULL EXTENT ALLOWED BY LAW, THE FOREGOING WARRANTIES AND REMEDIES ARE EXCLUSIVE AND ARE IN LIEU OF ALL OTHER WARRANTIES, TERMS OR CONDITIONS, EXPRESS OR IMPLIED, EITHER IN FACT OR BY OPERATION OF LAW, STATUTORY OR OTHERWISE, INCLUDING WARRANTIES, TERMS OR CONDITIONS OF MERCHANTABILITY, FITNESS FOR A PARTICULAR PURPOSE, SATISFACTORY QUALITY, CORRESPONDENCE WITH DESCRIPTION, AND NON-INFRINGEMENT, ALL OF WHICH ARE EXPRESSLY DISCLAIMED. POLYCOM NEITHER ASSUMES NOR AUTHORIZES ANY OTHER PERSON TO ASSUME FOR IT ANY OTHER LIABILITY IN CONNECTION WITH THE SALE, INSTALLATION, MAINTENANCE, OR USE OF THIS SOFTWARE PRODUCT.

POLYCOM SHALL NOT BE LIABLE UNDER THIS WARRANTY IF ITS TESTING AND EXAMINATION DISCLOSE THAT THE ALLEGED DEFECT OR MALFUNCTION IN THE SOFTWARE PRODUCT DOES NOT EXIST OR WAS CAUSED BY YOUR OR ANY THIRD PERSON'S MISUSE, NEGLIGENCE, IMPROPER INSTALLATION OR TESTING, UNAUTHORIZED ATTEMPTS TO MODIFY THE PRODUCT, OR ANY OTHER CAUSE BEYOND THE RANGE OF THE INTENDED USE, OR BY ACCIDENT, FIRE, LIGHTNING, POWER CUTS OR OUTAGES, OTHER HAZARDS, OR ACTS OF GOD.

## **7. LIMITATION OF LIABILITY.**

TO THE MAXIMUM EXTENT PERMITTED BY APPLICABLE LAW, IN NO EVENT SHALL POLYCOM OR ITS SUPPLIERS BE LIABLE FOR ANY SPECIAL, INCIDENTAL, INDIRECT, OR CONSEQUENTIAL DAMAGES WHATSOEVER (INCLUDING, WITHOUT LIMITATION, DAMAGES FOR LOSS OF BUSINESS PROFITS, BUSINESS INTERRUPTION, LOSS OF BUSINESS INFORMATION, OR ANY OTHER PECUNIARY LOSS) ARISING OUT OF THE USE OR INABILITY TO USE THE SOFTWARE PRODUCT OR THE PROVISION OF OR FAILURE TO PROVIDE SUPPORT SERVICES, EVEN IF POLYCOM HAS BEEN ADVISED OF THE POSSIBILITY OF SUCH DAMAGES. IN ANY CASE, POLYCOM'S ENTIRE LIABILITY SHALL BE LIMITED TO THE GREATER OF THE AMOUNT ACTUALLY PAID BY YOU FOR THE SOFTWARE PRODUCT OR U.S. \$5.00; PROVIDED, HOWEVER, IF YOU HAVE ENTERED INTO A POLYCOM SUPPORT SERVICES AGREEMENT, POLYCOM'S ENTIRE LIABILITY REGARDING SUPPORT SERVICES SHALL BE GOVERNED BY THE TERMS OF THAT AGREEMENT.

## **8. DISCLAIMER.**

Some countries, states, or provinces do not allow the exclusion or limitation of implied warranties or the limitation of incidental or consequential damages for certain products supplied to consumers, or the limitation of liability for personal injury, so the above limitations and exclusions may be limited in their application to you. When the implied warranties are not allowed to be excluded in their entirety, they will be limited to the duration of the applicable written warranty. This warranty gives you specific legal rights which may vary depending on local law.

## **9. EXPORT CONTROLS.**

The Software Product may not be downloaded or otherwise exported or re-exported (i) into (or to a national or resident of) Cuba, North Korea, Iran, Syria, Sudan, or any other country to which the U.S. has embargoed goods; or (ii) to anyone on the U.S. Treasury Department's List of Specially Designated Nationals or the U.S. Commerce Department's Table of Denial Orders. By downloading or using this Software Product, you are agreeing to the foregoing and you are representing and warranting that you are not located in, under the control of, or a national or resident of any such country or on any such list. If you obtained this Software Product outside of the United States, you are also agreeing that you will not export or re-export it in violation of the laws of the country in which it was obtained.

## **10. MISCELLANEOUS.**

**10.1 Governing Law.** This Agreement shall be governed by the laws of the State of California, as such laws are applied to agreements entered into and to be performed entirely within California between California residents, and by the laws of the United States. The United Nations Convention on Contracts for the International Sale of Goods (1980) is hereby excluded in its entirety from application to this Agreement.

**10.2 General.** This Agreement represents the complete agreement concerning this license and may be amended only by a writing executed by both parties. If any provision of this Agreement is held to be unenforceable, such provision shall be reformed only to the extent necessary to make it enforceable.

**10.3 Contact.** If you have any questions concerning this Agreement, or if you desire to contact Polycom for any reason, please contact the Polycom office serving your country.

## Polycom SpectraLink 8400 Series Wireless Handset

**10.4 U.S. Government Restricted Rights.** The software and documentation provided by Polycom pursuant to this Agreement are “Commercial Items,” as the term is defined at 48 C.F.R. §2.101, consisting of “Commercial Computer Software” and “Commercial Computer Software Documentation,” as such terms are used in 48 C.F.R. §12.212 or 48 C.F.R. §227.7202, as applicable. Consistent with 48 C.F.R. §12.212 or 48 C.F.R. §§227.7202-1 through 227.7202-4, as applicable, the Commercial Computer Software and Commercial Computer Software Documentation are licensed to United States Government end users (1) only as Commercial Items and (2) with only those rights as are granted to all other users pursuant to the terms of this Agreement. Contact: Polycom Corporate Headquarters at 4750 Willow Road, Pleasanton, CA 94588, USA. Phone: 925.924.6000. Online: [www.polycom.com](http://www.polycom.com)