





Each SpectraLink family of products only works with other members of the same family. If you have any questions about product compatibility, contact your system administrator.

SpectraLink 8400 Series

Use only 8400 Series products with other 8400 Series products as identified by the model number located on the label of the product.

SpectraLink 8452 Wireless Telephone	8452
SpectraLink 8450 Wireless Telephone	8450
SpectraLink 8440 Wireless Telephone	8440
Speakerphone Dock	8410
USB Charger	SA106B-05
Dual Charger	DCA39
Quad Charger	DCA40
Standard Capacity Battery Pack	RS657
Extended Capacity Battery Pack	RS658

The *Polycom SpectraLink 8400 Series Wireless Handset User Guide* is your complete reference for utilizing all of the features of this handset. It may be found online at:

http://support.polycom.com/PolycomService/support/us/support/voice/wi-fi/spectralink_8400_wireless.html

Table of Contents

Package Contents	3
The Home Screen	6
The Session Manager	8
Status and Call Icons	9
Basic Handset Features	10
Using the Barcode Reader	17
Accessories	18
Offer for Source for GPL and LGPL Software.....	23
Warranty and Copyright	24

Package Contents



This booklet is a basic guide to getting started with your SpectraLink® 8400 Series Wireless Telephone.

Front View – All Models

LED indicator

Model number

Full-color LCD display

Soft keys

Access context-sensitive features

Home key

Returns you to the *Home* screen

Navigation keys

▲ and ▼
Scroll through menus and fields
◀ and ▶
Move cursor

Start key

- Opens the Dialer from the *Home* screen
- Initiates a call from the Dialer
- Answers an incoming call

Back key

Returns to the previous menu level or to the *Home* screen

OK key

- Selects menu items
- Enables or disables menu items

Keypad

While in *Multi Key Answer Mode* you can use any of these keys to answer an incoming call instead of pressing the **Start** key or **Answer** soft key

End key

- Ends the call or returns to the *Home* screen
- Rejects an incoming call
- Terminates a conference call
- Powers the handset on or off when held down for about two seconds

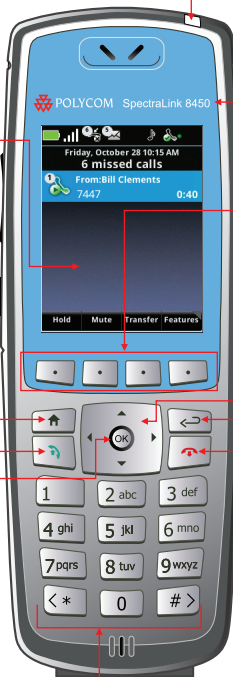

Side View – 8450/8452

Barcode reader

Volume up

Volume down

Talk button
(PTT)

Barcode reader
scan button

Headset jack
(Lift the cover for
access)

USB interface
(Lift the cover for
access)

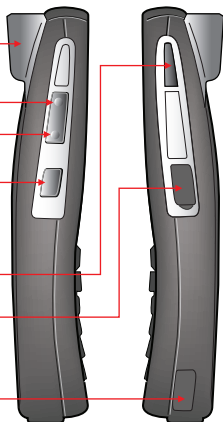

Side View – 8440

Volume up

Volume down

Talk button
(PTT)

Headset jack
(Lift the cover for
access)

USB interface
(Lift the cover for
access)

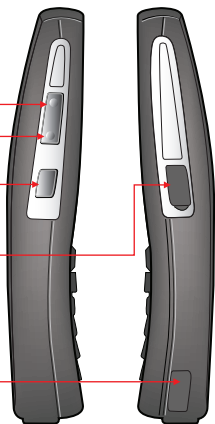

Rear View

Noise-cancelling
Microphone

Barcode reader
(8450/8452 only)

Speakerphone

Battery Pack
removal latch

Battery Pack

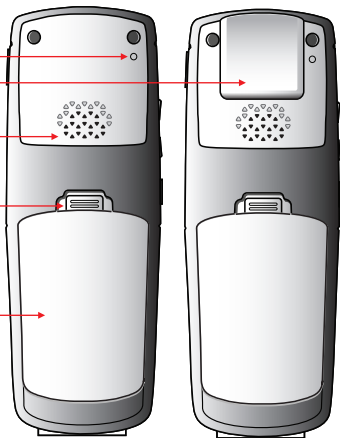

The Home Screen

The Home screen provides you with information about the status of the handset and the Home icons.

Status bar

Date and time

Extension

Current profile

Home icons:

Messages

Settings

Contacts/Call Lists

Applications
(not shown)

Soft key labels

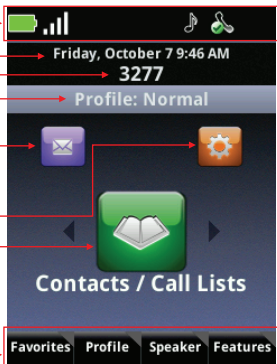

Home Icons

The Home icons allow you to access your handset's features from the Home screen. Use the ◀ and ▶ keys to rotate the Home icons. Press the **OK** key to select the center icon.

Contacts/Call Lists

The Contacts/Call Lists icon gives you access to your Contact Directory and your Corporate Directory, if available. For more information, see **Contact Directory** on page 14.

Messages

The Messages icon gives you access to Voicemail and Instant Messages. For more information, see **Voicemail** on page 14, and **Instant Messaging** on page 15.

Settings

The Settings icon opens a menu for configuring many handset features. See your User Guide for a complete list of these options.

Applications

Depending on the configuration of your handset, a menu of custom applications may be accessible by selecting the Applications icon from the Home screen. See your system administrator for information about any applications listed on this menu.

Shortcut Menus

The soft keys at the bottom of the display allow you to select functions. The gray triangles in the upper right corner of the soft keys indicate that there is a shortcut menu with additional options. Use the shortcut menus to quickly find the options you want. Use the ▲ and ▼ navigation keys to highlight an option, and choose the option by pressing OK. Alternatively, you can press the number of the option on the keypad to instantly activate it. Grayed options are not available.

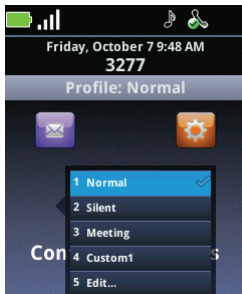





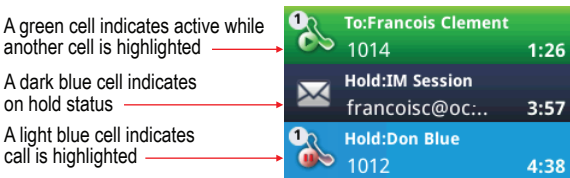
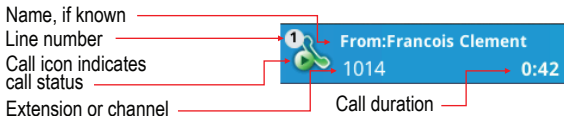









The Session Manager

Use your handset to manage up to eight communication sessions - calls, broadcasts, chats, and alerts - at any one time and in any combination. Each communication session is shown as a color-coded cell in the Session Manager screen. Cells display with a call icon indicating call status, a line number indicator, the name and extension/channel of the party, and the call duration, as shown next:



















When a cell is highlighted, soft keys display that you can press to affect that call while other cells remain unaffected. Use the ▲ and ▼ navigation keys to scroll to and highlight a cell.

Status and Call Icons

Status Icon	Indication
	Battery full
	Signal strength with location services
	Mute
	Do not disturb
	Missed call with number indicator
	Voicemail with number indicator
	Bluetooth available
	Bluetooth connected
	Profile: Normal
	Profile: Silent
	Profile: Custom
	Profile: Meeting
	All Phone lines are available
	Phone and/or IM line are unavailable

With green dot means active call

With red dot means call on hold

Call Icon	Indication
	Incoming call ringing
	Outgoing call
	Call active
	Call on hold
	IM Call on hold
	Conference call
	Conference leg/with HD audio
	PTT/Page receive
	PTT/Page transmit
	PTT/Page idle
	IM Presence indicator
	Dialer-Outgoing call
	Dialer-Incoming call
	Dialer-Missed Call
	Call list-Outgoing
	Call list-Incoming
	Call list-Missed
	IM call history Missed IM call

Basic Handset Features

Basic handset features offer you the ability to place, answer, end, hold, resume, and otherwise manage your incoming and outgoing calls. Other basic features include muting, transferring, forwarding, and conference calls.

Placing a Call

You can begin a call using one of the following methods:

Enter a Number

Entering numbers using the handset keypad is the default dialing mode. Pressing any number on the keypad opens the Dialer, which will automatically display similar numbers from your Contact Directory for you to select. As you enter additional numbers, the list is filtered. You can choose a contact from the list or continue to enter the number. Press the **Start** key to make the call.

Enter a number
in the number field

The Contact Directory
list will be filtered
according to the
number entered

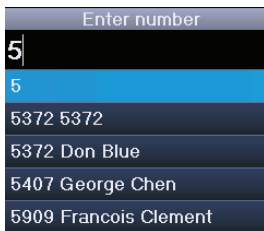

Enter a Name

To place a call to an existing directory contact by entering the name, press the **Start** key to open the Dialer. Select the **Entry Mode** soft key and select the **Name** option. As you enter the letters of the first or last name, the list of contacts shown is filtered. Highlight the name and press the **Start** key.

Call a Contact

Navigate to **Contacts/Call Lists > Contact Directory**. Contacts are sorted alphabetically. Scroll to highlight or use the **Search** soft key. Press the **Start** key to dial the number.

Use Speed Dial

Press the **Favorites** soft key from the Home screen to display the shortcut menu of *Favorites*—those contacts with speed dial numbers 1-10. Dial any contact by pressing the corresponding speed dial index number(s) on the keypad. Index numbers are assigned when a contact is entered. See **Contact Directory** on page 12.

Answering a Call

Press the **Start** key. If Multi Key Answer is enabled, press any keypad key (except soft keys and side buttons).

Make an Emergency Call

If programmed in your facility, you can make an emergency call by pressing the **Features** soft key and then pressing the **Speed Dial** option and selecting the emergency number from the list.

Incoming Call Management

When you are in an active call, the call window replaces the Session Manager when you receive another call. You can:

- Reject the call by pressing **End**. If voicemail is available, the call will be routed to voicemail.
- Silence the ring by pressing the **Ignore** soft key. The call will appear in the Session Manager until it stops ringing. If unanswered, it will be routed to voicemail, if available.
- Answer the call by pressing **Start** which places the active call on hold.
- To end the current call and answer the incoming call, press **Ignore** to open the Session Manager and press **End** to end the current call. Then press **Start** to answer the incoming call.
- Forward the call to another number by pressing the **Forward** soft key and entering the extension number. See **Forward an Incoming Call** on page 13.

Microphone Mute

The **Mute** soft key appears during active calls. Press this key to mute the microphone.

You can still hear all other parties while Mute is enabled, but other parties cannot hear you.

The **UnMute** soft key appears while Mute is enabled. To disable Mute, press the **UnMute** the soft key.

Call Hold and Resume

The **Hold/Resume** soft key appears during active calls. Press this key to place the highlighted call on hold. Press it again to resume the call.

Keypad Lock

Your keypad can be locked so you do not make inadvertent calls. From the Home screen, press the **Feature** soft key and select **Keypad Lock**. To unlock the keypad, repeat this sequence.

Volume Adjustment

Press the **volume** buttons on the left side of the handset to adjust the call volume of the active call. Press these buttons during ringing to adjust the ringer volume.

Hands-free Options

You can plug a headset into the headset jack on the right side of the handset. The headset icon will display. Bluetooth headsets can be used. Navigate to **Settings > Bluetooth** for pairing options. See the *User Guide* for additional directions.

Transfer and Conference Calls

During an active call, either the Transfer or Blind Transfer soft key will display. The key not displayed and the Conference options are listed on the Features flyout menu.

Blind transfer

1. Connect to the first party.
2. Select the **Blind Transfer** soft key or **Features** option to open the Dialer (the active call is placed on hold).
3. Place a call to the target party.
4. The transfer is complete when the target party answers.

Attended Transfer

1. Connect to the first party.
2. Select the **Transfer** soft key or **Feature** option to open the Dialer.
3. Place a call to the target party.
4. When the party answers, you can explain that you are going to transfer the call to [the party on hold].
5. Hang up your end of the call. The other two parties remain in call. If you want to remain on the call, do not hang up. Select the **Conference** option on the **Features** flyout and all three parties are now connected.

Conference call

1. Connect to the first party.
2. Select **Conference** from the **Features** menu.
3. Dial the next party.
4. Select the **Conference** soft key to join all parties in the conference call.

You can also conference two separate calls by using the **Join** option on the **Features** menu.

Conference Behavior

- When the Active Conference cell is highlighted, you can use the **Mute** key to mute your microphone. The **Hold** and **End** soft keys affect every participant in the conference call.
- When a participant cell is highlighted, you can use **FarMute** to mute the participant, the **End** key will disconnect the participant, **Hold** will place that participant on hold.
- Pressing the **Feature** soft key, **Split** option will split the conference into two separate held calls.

Do Not Disturb (DND)

DND sends all calls to Voicemail, if available. Navigate to **Settings** > **Features** > **Do Not Disturb**. Enable or disable as needed.

Forward an Incoming Call

While the handset rings, select the **Forward** soft key. The Forward-to-Dial screen appears. The screen displays the last number you forwarded calls to (either statically or dynamically). To

forward the call to a different number, enter the target number as you would through the Dialer.

Forward All Calls

1. Navigate to **Settings > Features > Forward**.
2. Select Forwarding Type: **Always, No Answer, or Busy**.
3. Enter the number of the desired call destination. For No Answer, enter the number of rings before forwarding.
4. Press the **Enable** soft key.

To disable call forwarding:

Perform steps 1 and 2 above, but press the **Disable** soft key.

Voicemail

When Voicemail is configured, the Voicemail icon in the Status Bar indicates one or more new Voicemail messages.

To listen to voice messages:

1. Select the Messages icon from the Home screen. **Urgent, New** and **Old** options are available. Select one of these options.
2. Press the **Connect** soft key, and then follow the voice prompts. Use the **Clear** soft key to clear Voicemail messages.

Call Lists

Navigate to **Contacts/Call Lists** and press **OK**. Press the **Type** soft key to specify which type of call you wish to view: **Missed, Received or Placed Calls**. Press the **Back** key to return to the Call list which now displays the selected type. Press the **Info** soft key to view the call details. You may then dial, edit, save or delete the call.

Contact Directory

Contacts can be dialed, added, edited, searched and deleted. Note that contacts can be added from the Corporate Directory if available in your facility.

Navigate to **Contacts/Call Lists > Contact Directory**. A Corporate Directory option may be available.

- Use the **Edit, Add, Search, and Delete** soft keys to customize your contacts. Note that you can only **Add** and **Search** the Corporate Directory.
- Press the **Encoding** soft key to access special characters, other languages and capitalization options.

Use the following as a guide when adding or editing a contact in the Contact Directory:







<u>Field/Option</u>	<u>Description/Function</u>
First Name/ Last Name	Both names are searchable; the list is sorted alphabetically by last name.
Contact	The phone number entered for the contact.
Speed Dial Index	Automatically assigned but can be changed/overridden. Index numbers 1-10 will appear on the shortcut menu.
Label	Identify the contact with a short description, such as Sales.
Ring Type	Choose a ring identifier from the dropdown list to specify a unique ring tone for this contact.
Divert Contact	Enter a number to divert calls from this contact to if Auto Divert is enabled.
Auto Reject	Enable this option to block all calls from this contact.
Auto Divert	Enable this option to divert all calls from this contact to the Divert Contact number (see Divert Contact)
IM Name	The Instant Messaging identifier for this contact.

Instant Messaging (if available)

Once you have set up a contact with an instant message (IM) name, the IM icon will display to the left of the name in the Contact Directory to indicate chat availability.

When you receive a chat, a chat window opens. You can press the **Start** key to reply or press the **End** soft key to send the chat to the Message Center.

IM Status Icons

	Available		DND
	Busy		Offline
	Away		No info

Push to Talk (if configured)

To set Push to Talk (PTT) options, navigate to **Settings > Preferences > Paging/PTT Config**.

<u>Field/Option</u>	<u>Description/Function</u>
Make a PTT broadcast	Press and hold the Talk button. Wait for the display to show <i>Transmitting...</i> and then speak into the microphone.
Answer a PTT broadcast	Press and hold the Talk button during the 10-second wait period.
End a wait period	Press the End key.
Select a different PTT channel	Press and release the Talk button. Use the ▲ and ▼ keys to highlight the desired channel. Press OK to select.
Hear a PTT broadcast while on a phone call	Place the telephone call on hold. Now you can hear the PTT broadcast.
End a PTT broadcast	Press the End key to exit the PTT broadcast and close the session cell.
Change the PTT volume	Press the up/down volume buttons on the side of the handset while transmitting or receiving a PTT broadcast.
Start a telephone call during a PTT broadcast	Press the Start key and dial the number. PTT transmissions will be overridden during the telephone call.
Answer a telephone call during a PTT broadcast	Press the Start key. PTT transmissions will be overridden by the telephone call.
Turn off PTT	Disable PTT in the Settings menu accessed through the Settings icon on the Home screen.

Additional PTT information is available in the *User Guide for the SpectraLink 8400 Wireless Handsets*.

Set Profile

Your SpectraLink 8400 handset has four configurable Profiles which can be customized for event notifications such as incoming calls or PTT sessions:

Normal	Audible alerts
Silent	All handset sounds are silenced
Meeting	Vibrates to notify of incoming calls
Custom	Can be tailored to specific needs

The chosen active profile can be changed from the Home screen by pressing the **Profile** soft key and selecting one of the options from the Profile shortcut menu.

Set Other Preferences

To access other Preferences, choose **Settings> Preferences** and select one of the following options:

1. Language
2. Time and Date
3. Headset Memory
4. Background
5. Screen Capture
6. Auto Answer
7. On-Hook dialing
8. Easy Answer
9. Paging/PTT Config

Using the Barcode Reader (8450/8452 only)

The barcode scanner is located at the top rear of the 8450/8452 handset. It is used in conjunction with an on-board application or a PC-based application. See your system administrator or consult your User Guide for complete information.

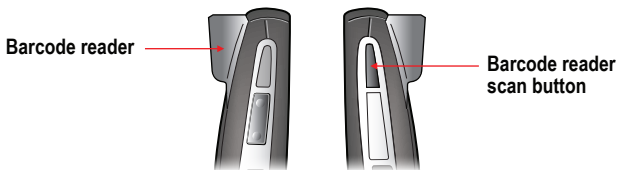

Accessories

These accessories are designed to enhance your SpectraLink 8400 Series Wireless Telephone. For more information, contact your reseller, or visit

http://www.polycom.com/forms/contact_polycom.html

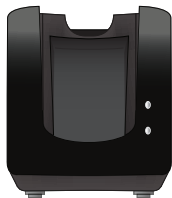

Dual Charger



Speakerphone Dock



Quad Charger



Battery Pack



Extended Battery Pack



USB Charger

Battery Packs

Your handset is powered by a removable Battery Pack that you will need to recharge periodically. You must fully charge your handset's Battery Pack before you use it for the first time. Depending on the type of charger you use, this might take several hours.

<u>Type</u>	<u>Talk Time</u>	<u>Standby Time</u>	<u>Charging Time*</u>
Standard (RS657)	8 hours	80 hours	3.5 hours typical*
Extended (RS658)	12 hours	120 hours	5 hours typical*

*Using the Quad Charger

Charging Icon

The charging icon on the handset indicates the charging status of the Battery Pack in the handset:



Battery Pack charging, handset in charger



Battery Pack fully charged, handset in charger



Battery Packs should be fully charged before first use.



Do not remove the Battery Pack to power off the handset. Log off or power off the handset and then remove the Battery Pack if you need to replace it.

Battery Pack Removal and Replacement

To remove the Battery Pack, press up on the latch on the back of the handset. The Battery Pack releases outward.

To replace, slide the tab of the Battery Pack into the bottom slot

**Battery Pack
Removal latch**

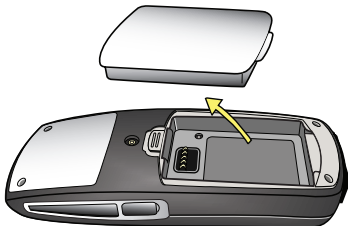
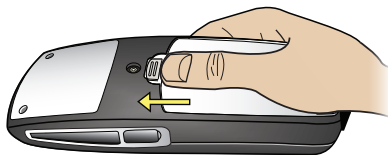
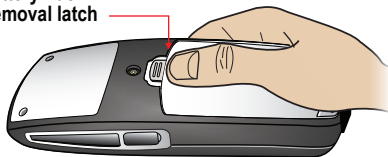

of the handset cavity. Gently press the top of the Battery Pack until it snaps into place. The Battery Pack should snap into position with minimal pressure, as shown next.

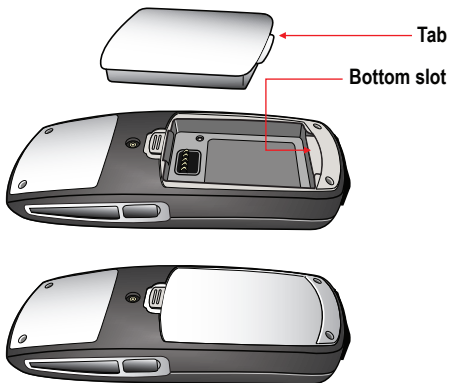

Using the Dual Charger

The Dual Charger (DCA39), shown next, is designed to charge the Battery Pack while keeping the handset operational. You can charge one Battery Pack by placing the handset in the front charging bay, and charge a second Battery Pack in the rear charging slot.



Spare Battery
Pack charging
slot

Handset
charging slot

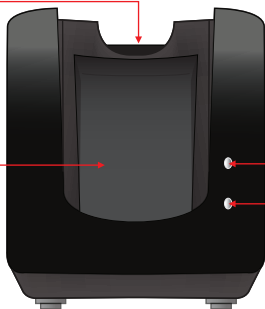

Battery Pack
charge LED

Handset charge
LED

<u>LED</u>	<u>Battery Pack charge</u>	<u>Handset charge</u>
Blinking	Charging	n/a
Solid green	Fully Charged	Properly seated
Off	Not seated or empty	Not seated or empty

NOTICE FOR SPECTRALINK 8440/8450/8452 PHONE USERS

OFFER for Source for GPL and LGPL Software

You may have received a Polycom SpectraLink 8400 Series Wireless Handset from Polycom that contains—in part—some free software (software licensed in a way that allows you the freedom to run, copy, distribute, change, and improve the software).

A complete list of all open source software included in the Polycom SpectraLink 8400 Series Wireless Handset, as well as related license and copyright information, is available at <http://downloads.polycom.com/voice/voip/offerForSourceVoiceProducts.html>. You may also obtain the same information by contacting Polycom by regular mail or email at the addresses listed at the bottom of this notice.

For at least three (3) years from the date of distribution of the applicable product or software, we will give to anyone who contacts us at the contact information provided below, for a charge of no more than our cost of physically distributing, the items listed in “Polycom Voice OFFER of Source for GPL and LGPL Software”, which is available at <http://downloads.polycom.com/voice/voip/offerForSourceVoiceProducts.html>.

Contact Information for Requesting Source Code:

Polycom Voice Open Source Manager
200-3605 Gilmore Way,
Burnaby, BC Canada
V5G 4X5
Tel: 604-453-9400
Fax: 604-453-9449
E-mail: OpenSourceVoice@polycom.com

Warranty and Copyright

The software included in this Product (including, without limitation, firmware and all updated thereto, including any software that may be downloaded electronically via the internet or otherwise (the "Software") is licensed, not sold. Customer shall not reverse compile, disassemble, or otherwise reverse engineer, embed with any other software product, or modify in any manner with respect thereto, the software in whole or in part.

LIMITED WARRANTY. Polycom warrants to the end user ("Customer") that this product will be free from defects in workmanship and materials, under normal use and service, for one year from the date of purchase from Polycom or its authorized reseller.

Polycom's sole obligation under this express warranty shall be, at Polycom's option and expense, to repair the defective product or part, deliver to Customer an equivalent product or part to replace the defective item, or if neither of the two foregoing options are reasonably available, Polycom may, in its sole discretion, refund to Customer the purchase price paid for the defective product. All products that are replaced will become the property of Polycom. Replacement products or parts may be new or reconditioned. Polycom warrants any replaced or repaired product or part for ninety (90) days from shipment, or the remainder of the initial warranty period, whichever is longer.

Products returned to Polycom must be sent prepaid and packaged appropriately for safe shipment, and it is recommended that they be insured or sent by a method that provides for tracking of the package. Responsibility for loss or damage does not transfer to Polycom until the returned item is received by Polycom. The repaired or replaced item will be shipped to Customer, at Polycom's expense, not later than thirty (30) days after Polycom receives the defective product, and Polycom will retain risk of loss or damage until the item is delivered to Customer.

EXCLUSIONS. Polycom will not be liable under this limited warranty if its testing and examination disclose that the alleged defect or malfunction in the product does not exist or results from:

- Failure to follow Polycom's installation, operation, or maintenance instructions.
- Unauthorized product repair, modification or alteration.
- Unauthorized use of common carrier communication services accessed through the product.
- Abuse, misuse, negligent acts or omissions of Customer and persons under Customer's control; or
- Acts of third parties, acts of God, accident, fire, lightning, power surges or outages, or other hazards.

WARRANTY EXCLUSIVE. IF A POLYCOM PRODUCT DOES NOT OPERATE AS WARRANTED ABOVE, CUSTOMER'S SOLE REMEDY FOR BREACH OF THAT WARRANTY SHALL BE REPAIR, REPLACEMENT, OR REFUND OF THE PURCHASE PRICE PAID, AT POLYCOM'S OPTION. TO THE FULL EXTENT ALLOWED BY LAW, THE FOREGOING WARRANTIES AND REMEDIES ARE EXCLUSIVE AND ARE IN LIEU OF ALL OTHER WARRANTIES, TERMS, OR CONDITIONS, EXPRESS OR IMPLIED, EITHER IN FACT OR BY OPERATION OF LAW, STATUTORY OR OTHERWISE, INCLUDING WARRANTIES, TERMS, OR CONDITIONS OF MERCHANTABILITY, FITNESS FOR A PARTICULAR PURPOSE, SATISFACTORY QUALITY, CORRESPONDENCE WITH DESCRIPTION, AND NON-INFRINGEMENT, ALL OF WHICH ARE EXPRESSLY DISCLAIMED. POLYCOM NEITHER ASSUMES NOR AUTHORIZES ANY OTHER PERSON TO ASSUME FOR IT ANY OTHER LIABILITY IN CONNECTION WITH THE SALE, INSTALLATION, MAINTENANCE OR USE OF ITS PRODUCTS.

SERVICE AGREEMENTS. Please contact your Polycom Authorized Reseller for information about service agreements applicable to your product.

SOFTWARE SUPPORT. Polycom will provide support for software running on the Product if all of the following conditions are satisfied:

- The product is under warranty or is covered by a Polycom service contract;
- The product is operating on a Polycom-approved partner platform; and
- The product software is the current major version or the next preceding major version (software revisions are labeled as "x.y.z," with the first two digits designating major versions).

Requests for software support should be made through the Polycom Reseller from whom the product was purchased.

LIMITATION OF LIABILITY. TO THE FULL EXTENT ALLOWED BY LAW, POLYCOM EXCLUDES FOR ITSELF AND ITS SUPPLIERS ANY LIABILITY, WHETHER BASED IN CONTRACT OR TORT (INCLUDING NEGLIGENCE), FOR INCIDENTAL, CONSEQUENTIAL, INDIRECT, SPECIAL, OR PUNITIVE DAMAGES OF ANY KIND, OR FOR LOSS OF REVENUE OR PROFITS, LOSS OF BUSINESS, LOSS OF INFORMATION OR DATA, OR OTHER FINANCIAL LOSS ARISING OUT OF OR IN CONNECTION WITH THE SALE, INSTALLATION, MAINTENANCE, USE, PERFORMANCE, FAILURE, OR INTERRUPTION OF ITS PRODUCTS, EVEN IF POLYCOM OR ITS AUTHORIZED RESELLER HAS BEEN ADVISED OF THE POSSIBILITY OF SUCH DAMAGES, AND LIMITS ITS LIABILITY TO REPAIR, REPLACEMENT, OR REFUND OF THE PURCHASE PRICE PAID, AT POLYCOM'S OPTION. THIS DISCLAIMER OF LIABILITY FOR DAMAGES WILL NOT BE AFFECTED IF ANY REMEDY PROVIDED HEREIN SHALL FAIL OF ITS ESSENTIAL PURPOSE.

DISCLAIMER. Some countries, states, or provinces do not allow the exclusion or limitation of implied warranties or the limitation of incidental or consequential damages for certain products supplied to consumers, or the limitation of liability for personal injury, so the above limitations and exclusions may be limited in their application to the customer. When the implied warranties are not allowed to be excluded in their entirety, they will be limited to the duration of the applicable written warranty. This warranty gives the customer specific legal rights which may vary depending on local law.

GOVERNING LAW. This Limited Warranty and Limitation of Liability shall be governed by the laws of the State of California, U.S.A., and by the laws of the United States, excluding their conflicts of laws principles. The United Nations Convention on Contracts for the International Sale of Goods is hereby excluded in its entirety from application to this Limited Warranty and Limitation of Liability. **COPYRIGHT.** All rights reserved under International and pan-American Copyright Conventions. No part of the contents of this manual may be copied, reproduced, or transmitted in any form or by any means, or translated into another language or format, in whole or part, without written consent of Polycom, Inc.

Polycom® and the logo design are registered trademarks of Polycom, Inc. in the United States, and various countries.

Do not remove (or allow any third party to remove) any product identification, copyright or other notices.

The software contained within this product is protected by United States copyright laws and international treaty provisions. Polycom, Inc., retains title and ownership of all property rights with respect to the software within this product.

LIMITATION OF WARRANTY: Products purchased hereunder may include an Application Programming Interface, including, without limitation, the XHTML based API and the OAI API or any other API that may be included in future software releases, which is resident on the Product and which enables external, third party control of the application-specific elements of the Product and provides third-party applications developers with tools for integration with the Product (the "API Software"). Polycom does not and cannot warrant that: (i) certain performance or results may be obtained using the API Software; (ii) the API Software is appropriate for Purchaser's purposes or particular application; or (iii) the API Software is error or bug free of that it will provide uninterrupted usage. ACCORDINGLY, THE API SOFTWARE AND ITS DOCUMENTATION IS LICENSED "AS IS" WITHOUT ANY WARRANTY AS TO THEIR QUALITY, PERFORMANCE, MERCHANTABILITY OR FITNESS FOR ANY PARTICULAR PURPOSE. THE ENTIRE RISK AS TO THE RESULTS AND PERFORMANCE OF THE API SOFTWARE IS ASSUMED BY PURCHASER.

SAFETY AND REGULATORY INFORMATION. For complete safety information, consult the *Safety Guide for SpectraLink 8000 Series Wireless Telephones*. For country certification and regulatory information, see the *SpectraLink 8000 Series Regulatory Information* leaflet.

Please contact your Polycom Authorized Reseller for assistance.

<http://www.polycom.com>



Contact Information:

Polycom, Inc. 4750 Willow Road, Pleasanton, CA 94588-2708 USA

1725-36721-001 Rev. C