

## IMPORTANT SAFETY INSTRUCTIONS

When using your telephone equipment, basic safety precautions should always be followed to reduce the risk of fire, electric shock and injury to persons, including the following:

1. Read and understand all instructions.
2. Follow all warnings and instructions marked on the product.
3. Unplug this product from the wall outlet before cleaning. Do not use liquid cleaners or aerosol cleaners. Use a damp cloth for cleaning.
4. Do not place this product on an unstable cart, stand or table. The product may fall, causing serious damage to the product.
5. Slots and openings in the cabinet and the back or bottom are provided for ventilation, to protect it from overheating, these openings must not be blocked or covered. The openings should never be blocked by placing the product on a bed, sofa, rug or other similar surface. This product should never be placed near or over a radiator or heater. This product should not be placed in a built-in installation.
6. Never push objects of any kind into this product through cabinet slots as they may touch dangerous voltage points or short out parts that could result in a risk of fire or electric shock. Never spill liquid of any kind on the product.
7. To reduce the risk of electric shock, do not disassemble this product, but take it to a qualified serviceman when service or repair work is required. Opening or removing covers may expose you to dangerous voltages or other risks. Incorrect re-assembly can cause electric shock when the appliance is subsequently used.
8. Unplug this product from the wall outlet and refer servicing to qualified service personnel in the following cases:
  - A. When the power supply cord or plug is damaged or frayed.
  - B. If liquid has been spilled into the product.
  - C. If the product has been exposed to rain or water.
  - D. If the product does not operate normally by following the operating instructions. Adjust only those controls that are covered by the operating instructions as an improper adjustment of other controls may result in damage and will often require extensive work by a qualified technician to restore the product to normal operation.
  - E. If the product has been dropped or the cabinet has been damaged.
  - F. If the product exhibits a distinct change in performance.
9. Do not allow anything to rest on the power cord. Do not locate this product where the cord will be damaged by persons walking on it.
10. Do not use this product near water, for example, near a bathtub, washbowl, kitchen sink, or laundry tub, in a wet basement, or near a swimming pool.
11. Avoid using a telephone (other than a cordless type) during an electrical storm. There may be a remote risk of electric shock from lightning.
12. Do not use the telephone to report a gas leak in the vicinity of the leak.
13. Use only the power cord and batteries indicated in this manual. Do not dispose of batteries in a fire. They may explode. Check with local codes for possible special disposal instructions.
14. **CAUTION:** Risk of explosion if battery is replaced by an incorrect type. Use only SANIK, type no. 3SN-AAA60H-S-J1
15.  Use only with class 2 power source 9V DC 200mA.
16. Plug the adaptor to the socket-outlet which near the equipment and shall be easily accessible.

## SAVE THESE INSTRUCTIONS

### INSTALLATION INSTRUCTIONS

1. Never install telephone wiring during a lightning storm.
2. Never install telephone jacks in wet locations unless the jack is specifically designed for wet locations.
3. Never touch uninstalled telephone wires or terminals unless the telephone line has been disconnected at the network interface.
4. Use caution when installing or modifying telephone lines.

## CONSUMER INFORMATION

This equipment complies with Part 68 of the FCC rules and the requirements adopted by the ACTA. On the bottom of this equipment is a label that contains, among other information, a product identifier in the format US:AAAEQ##TXXXX. If requested, this number must be provided to the telephone company.

An applicable certification jacks Universal Service Order Codes (USOC) for the equipment is provided (i.e., RJ11C) in the packaging with each piece of approved terminal equipment.

A plug and jack used to connect this equipment to the premises wiring and telephone network must comply with the applicable FCC Part 68 rules and requirements adopted by the ACTA. A compliant telephone cord and modular plug is provided with this product. See installation instructions for details.

The REN is used to determine the number of devices that may be connected to a telephone line. Excessive RENs on a telephone line may result in the devices not ringing in response to an incoming call. In most but not all areas, the sum of RENs should not exceed five (5.0). To be certain of the number of devices that may be connected to a line, as determined by the total RENs, contact the local telephone company.

If this equipment causes harm to the telephone network, the telephone company will notify you in advance that temporary discontinuance of service may be required. But if advance notice isn't practical, the telephone company will notify the customer as soon as possible. Also, you will be advised of your right to file a complaint with the FCC if you believe it is necessary.

The telephone company may make changes in its facilities, equipment, operations or procedures that could affect the operation of the equipment. If this happens the telephone company will provide advance notice in order for you to make necessary modifications to maintain uninterrupted service.

Please follow instructions for repairing if any (e.g. battery replacement section); otherwise do not replace or repair any parts of the device unless specified.

Connection to a party line service is subject to state tariffs. Contact the state public utility commission, public service commission or corporation commission for information.

This equipment is hearing aid compatible.

### NOTICE:

If your home has specially wired alarm equipment connected to the telephone line, ensure the installation of this [equipment ID] does not disable your alarm equipment. If you have questions about what will disable alarm equipment, consult your telephone company or a qualified installer.

### NOTICE:

According to telephone company reports, AC electrical surges, typically resulting from lightning strikes, are very destructive to telephone equipment connected to AC power sources. To minimize damage from these types of surges, a surge arrestor is recommended.

Should you experience trouble with this equipment, please Contact **Polyconcept USA, Inc., by calling Toll Free: 1 (800) 358-8122** for repair or warranty information. If the equipment is causing harm to the telephone network, the telephone company may request that you disconnect the equipment until the problem is resolved.

### WARNING:

Changes or modifications to this unit not expressly approved by the party responsible for compliance could void the user's authority to operate the equipment.

### NOTE:

This equipment has been tested and found to comply with the limits for a Class B digital device, pursuant to Part 15 of the FCC Rules. These limits are designed to provide reasonable protection against harmful interference in a residential installation. This equipment generates, uses and can radiate radio frequency energy and, if not installed and used in accordance with the instructions, may cause harmful interference to radio communications.

However, there is no guarantee that interference will not occur in a particular installation. If this equipment does cause harmful interference to radio or television reception, which can be determined by turning the equipment off and on, the user is encouraged to try to correct the interference by one or more of the following measures:

- Reorient or relocate the receiving antenna.
- Increase the separation between the equipment and receiver.
- Connect the equipment into an outlet on a circuit different from that to which the receiver is needed.
- Consult the dealer or an experienced radio/TV technician for help.

## **EQUIPMENT LIMITATIONS NOTICE**

### **NOTICE:**

This equipment meets the applicable Industry Canada Terminal Equipment Technical Specifications.

Before installing this equipment, users should ensure that it is permissible to be connected to the facilities of the local telecommunications company. The equipment must also be installed using an acceptable method of connection. The customer should be aware that compliance with the above conditions may not prevent degradation of service in some situations.

Repairs to certified equipment should be coordinated by a representative designated by the supplier. Any repairs or alterations made by the user to this equipment, or equipment malfunctions, may give the telecommunications company cause to request the user to disconnect the equipment.

Users should ensure for their own protection that the electrical ground connections of the power utility, telephone lines and internal metallic water pipe system, if present, are connected together. This precaution may be particularly important in rural areas.

### **CAUTION:**

Users should not attempt to make such connections themselves, but should contact the appropriate electric inspection authority, or electrician, as appropriate.

### **NOTICE:**

The Ringer Equivalence Number (REN) for this terminal equipment is 0.0. The REN assigned to each terminal equipment provides an indication of the maximum number of terminals allowed to be connected to a telephone interface. The termination on an interface may consist of any combination of devices subject only to the requirement that the sum of the Ringer Equivalence Numbers of all the devices does not exceed five.

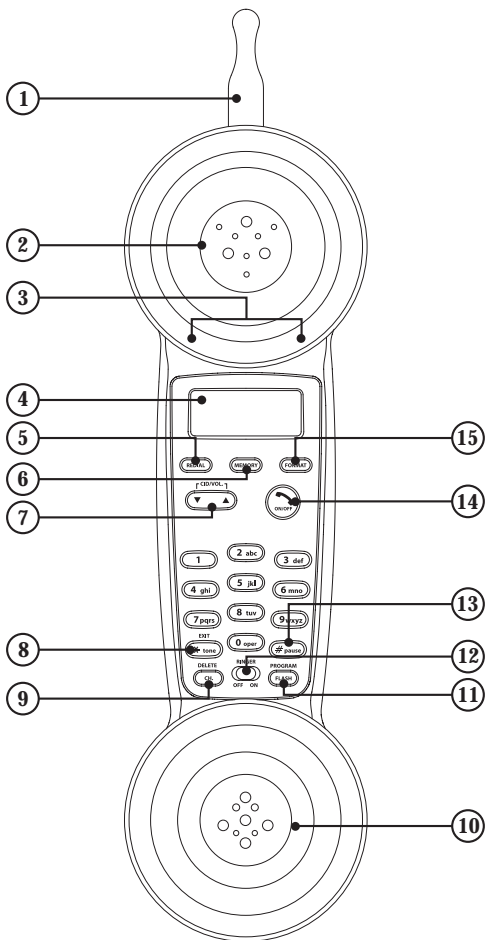

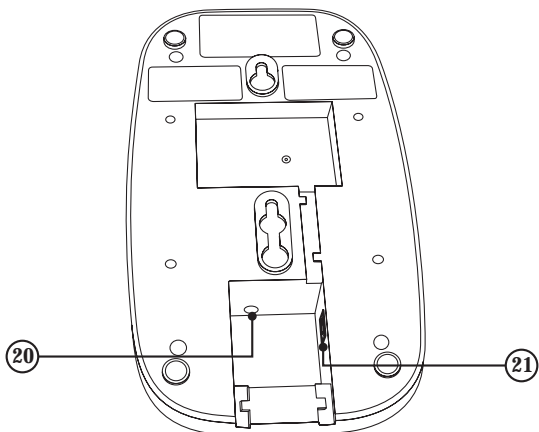
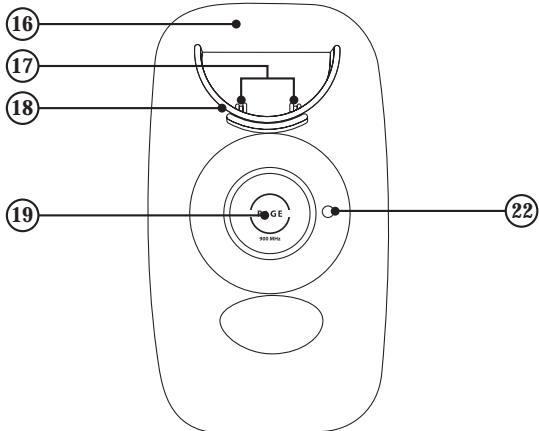

## CONTROLS

1. Handset Antenna
2. Ear Piece Cover
3. Battery Contact Plate
4. LCD Display
5. Redial Button
6. Memory Button
7. Caller ID/Volume (▲ and ▼) Button
8. Tone/Exit Button
9. Channel/Delete Button
10. Mouth Piece Cover
11. Flash/Program Button
12. Ringer Switch
13. Pause Button
14. Talk Button
15. Format Button
16. Base
17. Charge Contact plate
18. Cradle
19. Page Button
20. DC Jack
21. Telephone Line in Jack
22. Voice Mail/Charge/In-use Indicator

## IMPORTANT

**Charge the handset battery for 12 continuous hours prior to first use. The initial battery charge is important for best performance.**

## INTRODUCTION

- Your 900-MHz Retro Cordless Telephone is a fine-quality home communications product. It is carefully designed and produced by a world leader of consumer and industrial electronics equipment. With proper maintenance and care, it will provide you with years of enjoyment and convenience.

## MAIN FEATURES

### 900-MHz Technology

#### Extended Range

- The use of 900-MHz frequency band for signal transmission between base and handset means greater communication range compared to conventional 43-49 MHz cordless telephones.

#### Ultra-Low Noise

- The high frequency communication also features significantly reduced noise levels.

#### 40-Channel Auto/Manual Scan

- Your new telephone uses one of 40 channels in the 900-MHz frequency band. It automatically selects a clear channel every time you receive or place a call on the handset.

## COMPANDER PLUS Noise Reduction

The noise reduction technology now filters out more background noise.

- Caller ID\* and Caller ID with Call Waiting\*  
(\*Each feature works with your telephone company. A subscription is required.)
- 40-number Caller ID list
- 10-name/number directory
- Receiver volume control
- 3-line trilingual display
- Ringer On/Off switch
- Low battery warning

**Important:** To use all of the features of this phone, you must subscribe to either the standard Name/Number Caller ID Service or Caller ID with Call Waiting Service. To know who is calling while you are on the phone, you must subscribe to Caller ID with Call Waiting Service.

## GETTING STARTED

### Checking the package contents

- Make sure your package includes the items shown here.



Base



Handset



AC/DC Adaptor



Telephone Line Cord

## INSTALLATION

### Modular Jack

- To properly connect your phone to your telephone lines, you will need an RJ11 type modular phone jack. If you do not have a modular jack, call your local phone company to find out how to get one installed.

**Installation Note:** Avoid places near electrical equipment such as refrigerators, computers, TVs or fluorescent lamps. These may cause interference or reduce the operation range of the cordless telephone.

### Connections

- Battery pack must be connected to the handset before charging the phone. See drawings below for details.

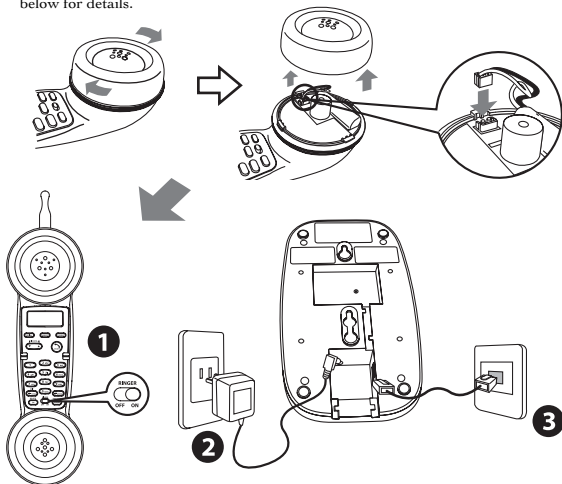

- Set the **Ringer Switch** (12) on the front of the handset to the "ON" position and place the handset on the base.

2. Plug the AC/DC adaptor into the **DC Jack** (20) on the bottom of the base and the other end into an electrical outlet. The **Voice Mail/Charge/In-use Indicator** (22) lights, verifying the battery is charging.  
**Important:**
    - Do not connect the telephone line to the modular jack until the phone has been charged for 12 continuous hours.
    - Charge the handset battery for 12 continuous hours prior to first use. The initial battery charge is important for best performance.
  3. Plug the telephone line cord into the **Telephone Line in Jack** (21) on the bottom of the base and into a modular jack.  
**Caution:** Use the original AC/DC adaptor, that came with this phone. Using other adaptors may damage the phone.
- NOTE:** The phone automatically defaults to touch tone dialing. To change to pulse (rotary) dialing, see **Tone/Pulse dialing**. If you do not know which type of service you have, check with your telephone company.

## Digital Security System

- Your cordless phone uses a digital security system to provide protection against false ringing, unauthorized access and charges to your phone line.
- When you place the handset in the base, the unit verifies its security code. After a power outage or battery replacement, place the handset in the base for about 20 seconds to reset the code.

## Mounting on Walls

- The unit has two mounting holes on the back side for this purpose. (Mounting hardware not included)

# INITIAL PROGRAMMING

- Before using this telephone the following 5 initial program set-ups must be completed:

## Language setting

1. Make sure the phone is off (not in TALK mode).
2. Press the **Flash/Program Button** (11), 1ENG 2FRA 3ESP shows on screen. English is factory set.
3. Use the handset number keys (or ▲/▼ keys) to enter the desired setting. For example, to choose French, press the number **2** key or press ▲/▼ key until displaying the French language.
4. Press the **Flash/Program Button** (11) to store selection. You will hear a confirmation tone.

## Area code setting

This is required to use Caller ID service from your telephone company.

5. After step 4 above, AREA CODE – shows on screen.
6. Use the handset keypad to enter your 3-digit area code.
7. Press the **Flash/Program Button** (11) to store selection. You will hear a confirmation tone.

## Ringer tone setting

8. After step 7 above, RINGER TONE 1 shows on the screen, Ringer tone 1 is factory set.
9. Use the number keys to enter the desired setting. For example, to choose Ringer Tone 2, press the number **2** key.
10. Press the **Flash/Program Button** (11) to store selection. You will hear a confirmation tone.

## Tone/pulse setting

11. After step 10 above, 1 TONE 2 PULSE shows on screen. Tone is factory set.
12. Use the number keys to enter the desired setting. For example, to choose Tone dialing, press the number **1** key.
13. Press the **Flash/Program Button** (11) to store selection. You will hear a confirmation tone.



## Default setting

- After step 13 above, DEFAULT INO shows on screen. No is factory set.
- Use the number keys to enter the desired setting. For example, to choose Yes, press the number 2 key. "2 YES" will restore or reset the phone to original factory settings.
- Press the **Flash/Program Button** (11) to store selection. You will hear a confirmation tone.

## BASIC

### Receiving a call

- When the phone rings the screen shows caller information\*.
- Press the **Talk Button** (14).  
\*(If you do not subscribe to a caller ID service, there will be no information on display.) There will be "NO DATA" on display.

### Ringer switch

- The **Ringer Switch** (12) must be "ON" for the handset to ring during incoming calls.

### Volume

- While talking, press the **Caller ID/Volume (▲ and ▼) Button** (7) to control the receiver volume. There are four volume levels. Press ▲ to increase the volume level, and press ▼ to decrease. VOL 1 is the lowest level and VOL 4 is the loudest.

### Making a call

- Press the **Talk Button** (14) before you dial and press it again to hang up.

### Redialing a call

- Press the **Talk Button** (14) and then the **Redial Button** (5) to redial the last number you dialed (up to 32 digits). If you get a busy signal, and want to keep dialing the number, just press the **Redial Button** (5) again (you do not have to turn the phone off and back on).

### Pre-dialing

- Make sure the phone is OFF (not in TALK mode).
- Enter the telephone number. The telephone number shows on screen.
- Press the **Talk Button** (14). The number is dialed automatically.

**Note:** You may enter up to 32 pre-dial digits.

### Flash button

- Use the **Flash/Program Button** (11) for special calling services such as Call Waiting or Call Transfer. You must subscribe to these services available through your local phone company.

**Tip:** Do not use **Talk Button** (14) to activate custom calling services or you'll hang up the phone.

### Voice mail/Charge/In-use indicator

- Flashes when you have a new voice mail.
- Lights when the handset is being charged in the base.
- Lights when the handset is in use.

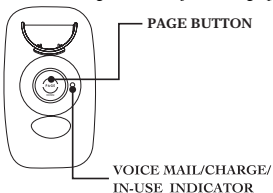

### Voice mail

- When you subscribe to a voice mail service offered by your phone company, the phone alerts you when voice mail has been received MESSAGE WAITING appears on screen for 60 seconds when a voice mail is received. The **Voice Mail/Charge/In-use Indicator** (22) on the base flashes to indicate there is voice mail waiting. After the voice mail has been reviewed MSG WAITING OFF appears on screen and the **Voice Mail/Charge/In-use Indicator** (22) stops flashing.

**This indicator does not work with your answering machine.**

**Note:** The phone will only work with an FSK type of VMWI system. It will not work with the Stutter Dial Tone type of VMWI system.

### Channel button

- Press and release the **Channel/Delete Button** (9) to advance to the next channel to get rid of static while talking.

### Temporary tone

This feature enables pulse (rotary) service phone users to access touch-tone services offered by banks, credit card companies, etc.

1. Call the bank's information line.
2. Press the **Tone/Exit Button** (8) after your call is connected.
3. Follow the voice instructions to complete your transaction.
4. Hang up when finished. The phone returns to pulse (rotary) service.

### Exit button

- Press the **Tone/Exit Button** (8) to cancel any command you initiated.

### Handset locator

- This feature helps to locate a misplaced handset. Press the **Page Button** (19) on the base. The handset beeps continuously for about two minutes or until you press any key on the handset. Press the **Page Button** (19) to cancel.

**Note:** The **Ringer Switch** (12) does not have to be "ON" for this feature to work.

## CALLER ID FEATURES

This phone receives and displays caller's information when you subscribe to a Caller ID service from your telephone company. This information can include the phone number, date, and time: or the name, phone number, date, and time. The phone can store up to 40 callers for later review.

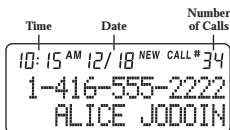

### Caller ID with Call Waiting

- When you subscribe to Caller ID with Call Waiting service from your phone company, you are able to see who is calling when you hear the call waiting beep. The caller information appears on screen after you hear the tone.
  - Press the **Flash/Program Button** (11) to put the first caller on hold and answer the incoming call.
  - Press the **Flash/Program Button** (11) again to return to the first caller.

**Important:** In order to use the Caller ID functions with this phone, you must subscribe to either the standard Name/Number Caller ID Service or Caller ID with Call Waiting Service. Services may vary by region. Contact your phone company.

### Caller ID list

- When you receive a call, the information is transmitted by the phone company to your Caller ID telephone between the first and second ring and then stored in the Caller ID memory.
- When the memory is full, any new call will automatically replace the oldest call in memory. NEW appears on screen for calls received that have not been reviewed. REPT indicates that a new call from the same number was received more than once.

### Reviewing Caller ID list

As calls are received and stored, the Caller ID list is updated to let you know how many calls have been received.

- Press the **Caller ID/Volume (▲ and ▼) Button** (7) to scroll through the list from the most recent to the oldest or from the oldest to the most recent.

## Dialing a Caller ID number

1. Make sure the phone is off (not in TALK mode).
2. Use the **Caller ID/Volume (▲ and ▼) Button (7)** to display the desired Caller ID entry.
3. Press the **Talk Button (14)**. The number is dialed automatically.

## Transferring Caller ID entries to the directory

You can transfer up to 10 Caller ID entries to your phone's directory.

1. Use the **Caller ID/Volume (▲ and ▼) Button (7)** to scroll to the call entry you want to transfer to the directory.

**Note:** Before transferring a caller ID number, make sure the number appears in proper digits for your dialing area. If not, change it using the **Format Button (15)**. For example, if the caller ID number appears 1-416-222-5555 but it is not a long distance number, press the **Format Button (15)** until it shows 416-222-5555 (without 1).

### Caller ID number display

- Use the **CID/VOL** keys to scroll to the phone number you want to store or call.
- Press the **Format Button (15)** to change to the required number of digits.
- The **Format Button (15)** lets you select how many digits of the number to be displayed.

**7** — 7-digit telephone number.

**10** — 3-digit area code + 7-digit telephone number.

**11** — Long distance code 1 + 3-digit area code + 7-digit telephone number.

2. Press the **Memory Button (6)**.
3. Press the desired memory location number. Example: press number **1** key to store the caller in location 1.
4. You will hear a confirmation tone.

## To replace a name/number stored in the directory with a new call entry:

1. Repeat steps 1 through 3 above.
2. Press the **Memory Button (6)** and a memory location button such as 1, REPLACE MEMO? Shows on screen.
3. Press the **Tone/Exit Button (8)** to exit, or press the **Memory Button (6)** again and the new call entry number replaces the current name/number in that memory location. You will hear a confirmation tone.

## Deleting the displayed entry

1. Make sure the phone is off (not in TALK mode).
2. Use the **Caller ID/Volume (▲ and ▼) Button (7)** to display the desired Caller ID entry.
3. Press the **Channel/Delete Button (9)**. The screen shows DELETE?
4. Press the **Channel/Delete Button (9)** again to erase the displayed data. You will hear confirmation tone. The screen shows DELETED. Then the next Caller ID entry shows on screen.

## Deleting entire Caller ID list

1. Make sure the phone is off (not in TALK mode).
2. Use the **Caller ID/Volume (▲ and ▼) Button (7)** to display any Caller ID entry.
3. Press and hold the **Channel/Delete Button (9)** until the phone beeps and DELETE ALL? Shows on the screen.
4. Press the **Channel/Delete Button (9)** again to erase the entire list. You will hear confirmation tone and NO CALLS appears.

## DIRECTORY

- Store up to 10 names/numbers in the directory for quick dialing. The number can be up to 24 digits. The name can be up to 15 characters. This directory feature is in addition to the 40 Caller ID list.

## Storing a name/number in the directory

1. Make sure the phone is off (not in TALK mode).
2. Press the **Memory Button** (6).
3. Press the desired memory location (0 through 9).
4. Press the **Memory Button** (6) again. The screen shows ENTER NAME.

**Note:** If you do not want to enter the name, skip step 5.

5. For example, to enter the name Alice Roy:
  - Press the **2** key once for the letter A.
  - Press the **5** key three times for the letter L.
  - Press the **4** key three times for the letter I.
  - Press the **2** key three times for the letter C.
  - Press the **3** key twice for the letter E.
  - Press the **1** key to insert a space between the letter E and R.Continue to enter the letters of the last name.

**Note:** If you enter a wrong letter, press the **Channel/Delete Button** (9) to backspace.

6. Press the **Memory Button** (6) to save the name. The screen shows ENTER TEL NUMBR.
7. Use the number keypad to enter the telephone number you want to store (up to 24 digits).
8. Press the **Memory Button** (6) again to store the number. You will hear a confirmation tone.

## Changing a stored name/number

1. Repeat steps 1 through 7 in *Storing a name/number in the directory*.
2. Press the **Memory Button** (6) and REPLACE MEMO? Shows on screen.
3. Press the **Tone/Exit Button** (8) to exit, or press the **Memory Button** (6) again to replace with the new data just entered. You will hear a confirmation tone.

## Storing last-dialed number

1. Repeat steps 1 through 6 in *Storing a name/number in the directory*.
2. Press the **Redial Button** (5).
3. Press the **Memory Button** (6) to store the number. You will hear a confirmation tone.

## Making calls from the directory

1. Make sure the phone is off (not in TALK mode).
2. Press the **Memory Button** (6).
3. Use the **Caller ID/Volume (▲ and ▼) Button** (7) to scroll through directory until the desired name is shown.
4. Press the **Talk Button** (14). The number is dialed automatically.

- or -

1. Press the **Talk Button** (14).
2. Press the **Memory Button** (6).
3. Press number (0-9) for the desired memory location. The number is dialed automatically.

## Inserting a pause in the dialing sequence

- Press the **Pause Button** (13) twice within one second to insert a delay in the dialing sequence of a telephone number (in directory memory setting mode) when a pause is needed to wait for a dial tone. For example after you dial 9 for an outside line, or to wait for a computer access tone. P shows on screen. Each pause counts as 1 digit in the dialing sequence.

## Reviewing and deleting directory contents

1. Press the **Memory Button** (6), then use the **Caller ID/Volume (▲ and ▼) Button** (7) to view the directory.
2. While the desired entry is displayed, press the **Channel/Delete Button** (9). The screen shows DELETE?
3. Press the **Channel/Delete Button** (9) again to delete the entry. DELETED shows on screen.

## Chain dialing from the directory

- Use this feature to make calls that require a sequence of numbers such as using a calling card for a frequently called long distance number. You can dial each part of the sequence from a different entry of the directory. The following example shows how you can chain dial to make a call through a long distance service:

The Number for	Memory Location
Long distance access number	7
Authorization code	8
Frequently called long distance number	9

- Make sure the phone is on.
- Press the **Memory Button** (6) and then press 7.
- When you hear the access tone, press the **Memory Button** (6) again and then press 8.
- At the next access tone, press the **Memory Button** (6) and then 9.

**Tip:** Wait for the access tones between pressing the **Memory Button** (6), or your call might not go through.

## CHARGING THE HANDSET BATTERY

- When the battery is low, you will hear a short beep every 7 seconds in phone mode. Please put the handset on the **Cradle** (18) to charge the battery.

## CHANGING THE BATTERY

### Battery replacement and handling

- When the operating time becomes short even after a battery is recharged, please replace the battery.
- With normal usage, your battery should last about one year.

**Note:** Repeated short chargings may cause memory effect in the battery, which reduces use time of the battery. It is recommended not to put the handset on the cradle after each call.

- Caution:**
- Use only the specified battery type (3.6V, 600mAh).
  - Do not remove the battery from the handset to charge it.
  - Never throw the battery into a fire, disassemble it, or heat it.
  - Do not remove or damage the battery casing.
  - Remove battery if storing the phone over 30 days.

**Make sure the telephone is off before you replace the battery.**

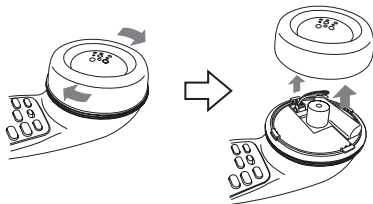

- Rotate the battery compartment cover clockwise to unlock then pull to remove as shown in drawings above.
- Disconnect the battery plug from the jack in the compartment and remove the battery.
- Insert the new battery and connect the cord into the jack.
- Put the battery compartment cover back on.
- Place handset on the base to charge.

**Note:** If the handset battery is removed for more than 5 minutes, the directory memory and the Caller ID memory will be erased.

---

**Charge the handset battery for 12 continuous hours prior to first use. The initial, uninterrupted battery charge is important for best performance.**

---

**Caution:** To reduce the risk of fire or personal injury, use a 3.6V, 600mAh battery.

### Power failure

- During the period that the power is off, you will not be able to make or receive calls with the telephone.
- After a power outage, place the handset in the base for about 20 seconds to reset the digital security code.

## LCD SCREEN MESSAGES

The following messages show the status of a call or the phone.

### INCOMPLETE DATA

- Caller information had been interrupted during transmission or the phone line is excessively noisy.

### ENTER NAME

- Prompt telling you to enter the name for one of 10 directory locations.

### ENTER TEL NUMBR

- Prompt telling you to enter the telephone number for one of 10 directory locations.

### DELETE?

- Prompt asking if you want to erase an entry in the Caller ID list or directory.

### DELETE ALL?

- Prompt asking if you want to erase entire Caller ID list.

### DELETED

- Prompt confirming the Caller ID/Directory entry is erased.

### END OF LIST

- Indicates that there is no additional information in Caller ID list.

### NEW

- Indicates new caller(s) in the Caller ID list.

### UNKNOW NAME/CALLER/NUMBER

- The incoming call is from an area not serviced by Caller ID or the information was not sent.

### PAGING

- The **Page Button** (19) is pressed on the base.

### BLOCKED CALL

- The caller has blocked name/number from transmission.

### BLOCKED NAME

- The caller's name is blocked from transmission.

**REPT**

- Repeat caller. Indicates that a new call from the same number was received more than once.

**NO DATA**

- No Caller ID information was received.

**EMPTY**

- Indicates a memory location is vacant.

**NO CALLS**

- No new calls received.

**MESSAGE WAITING**

- This appears for 60 seconds when you have just received a new voice mail. This message only appears if you subscribe to an answering service with your telephone company.

**MSG WAITING OFF**

- Appears when Voice Mail has been reviewed.

**SOUND SIGNALS**

Signal	Meaning
A long warbling tone	Signals an incoming call (with ringer on)
Two long beeps	Confirmation tone
One short and one long beep	Page signal
One short beep every 15 seconds	Low battery warning
Error tone	Three short beeps
Key feedback tone	Enabled
Key tone	Enabled

**TROUBLESHOOTING****CALLER ID****No display on screen**

- Is battery fully charged? Try replacing the battery. Make sure the battery is properly installed and connected.
- Make sure that the phone is connected to a non-switched electrical outlet. Disconnect the phone from the outlet and plug it in again.
- Did you subscribe to Caller ID service from your local telephone company?

**Caller ID error message**

- The phone displays this message if it detects anything other than valid Caller ID information during the silent period after the first ring. This message indicates the presence of noise on the line.

**Voice Mail/In-use/Charge indicator flashes**

- When you subscribe to a voice mail service from your phone company, the **Voice Mail/Charge/In-use Indicator** (22) on the base flashes when the phone is not in use to indicate there is a voice mail waiting. It stops flashing after the voice mail has been reviewed.

**TELEPHONE****No dial tone**

- Check all connections:
  - Is the AC/DC adaptor connected to a working outlet?
  - Is the telephone line cord connected to the base and the wall jack?

- Disconnect the base from the wall jack and connect another phone to the same jack. If there is no dial tone in the second phone, the problem might be your wiring or local service.
  - Is the handset out of range of the base?
  - Make sure the battery is properly charged (12 continuous hours).
  - Is the battery installed correctly?
  - Does the handset beep when you press the **Talk Button** (14)? The battery may need to be charged.

### **Dial tone is OK, but cannot dial out**

- Make sure the tone/pulse setting is programmed correctly.

### **Handset does not ring**

- Make sure the **Ringer Switch** (12) on the handset is turned to “ON” position.
- You may have too many extension phones on your line. Try unplugging some phones.
- See solutions for **No dial tone**.

### **You experience static, noise or fading in and out**

- Change channels.
- Is handset out of range? Move closer to the base.
- Does the base need to be relocated?
- Charge battery.
- Make sure base is not plugged into an outlet with another household appliance.

### **Handset beeps**

- Place handset in base for 20 seconds to reset the security code. If that doesn't work, charge battery for 12 continuous hours.
- Clean charging contacts on handset and base with a soft cloth, or an eraser.
- See solutions for **No dial tone**.
- Replace battery.

### **Dialing from directory**

- Did you program the memory locations of directory?
- Did you follow proper dialing sequence?
- Make sure the tone/pulse setting is programmed correctly.
- Did you reprogram directory after power outage or battery replacement?

## **RECYCLING NICKEL-METAL HYDRIDE BATTERIES**

NICKEL-METAL HYDRIDE BATTERIES MUST BE DISPOSED OF PROPERLY

- Please take the used battery to a store that recycles Ni-MH batteries.

## **MAINTENANCE**

To keep your telephone working, follow these guidelines:

- Avoid putting the phone near heating appliances and devices which generate electrical noise (for example, motors or fluorescent lamps).
- Do not expose to direct sunlight or moisture.
- Avoid dropping and other rough treatment of the phone.
- Clean with a soft cloth.
- Never use a strong cleaning agent or abrasive powder because this will damage the finish.
- Retain the original packaging in case you need to ship the phone at a later date.

### **Causes of poor reception**

- Aluminum siding.
- Foil backing on insulation.
- Heating ducts and other metal construction.
- The phone is too close to appliances such as microwaves, stoves, computers, etc.
- Atmospheric conditions, such as severe storms.
- Base is installed in the basement or lower floor of the house.



- Base is plugged into an AC outlet with other electronic devices.
- Other device is using the same frequency.
- Handset battery is low.
- Handset is out of range.

## **TO SERVICE YOUR UNIT, CONTACT:**

Polyconcept USA, Inc.  
69 Jefferson Street,  
Stamford, CT 06902,  
USA  
Phone: 1-800-358-8122

## Template for Wall mount

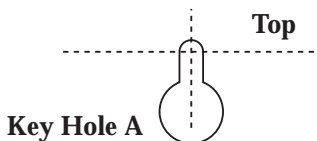

**Use this template to determine position of telephone on wall, and where to locate screw holes.**

**Remove template from wall before inserting plastic anchors or screws.**

**Use only for wall installation of telephone set.**

