

# M-TECH

## *SX 35 DSC*

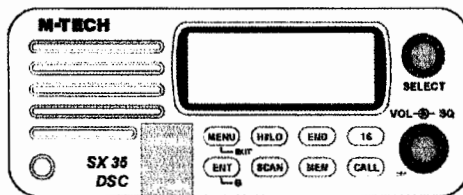

## OWNER'S HANDBOOK

## WELCOME

Welcome to the M-Tech SX35DSC. This instruction manual provides the information necessary for proper operation of your SX35DSC VHF radiotelephone. To avoid problems and obtain the best results, please read this instruction manual carefully before operating the unit.

You should become familiar with the FCC rules and regulations regarding the proper operating procedures, channels assigned for your type of operation, and restrictions that apply to the use of United States channels.

## IMPORTANT NOTICE

This space is provided to record a description of your SX35DSC VHF radiotelephone equipment. Enter the information for a permanent record.

Manufacturer :

Description : DSC VHF radiotelephone

Model Number : SX35DSC

Serial Number :

Date of Purchase :

Station License Number :

Call Sign :

## NOTICE

This device is only an aid to navigation. Its performance can be affected by many factors including equipment failure or defects, environmental conditions, and improper handling or use. It is the user's responsibility to exercise common prudence and navigational judgement, and this device should not be relied upon as a substitute for such prudence and judgement. Your SX35 DSC VHF radio generates and radiates radio frequency (RF) electromagnetic energy (EME). This equipment must be installed and operated in accordance with the instructions contained in this handbook. Failure to do so can result in personal injury and/or product malfunction.

### **Antenna Mounting and EME Exposure**

For optimal radio performance and minimal human exposure to radio frequency electromagnetic energy, make sure the antenna is:

- Connected to the radio before transmitting
- Properly mounted
- Located where it will be away from people
- Located at least three feet (91 cm) from the Base Station transceiver and handsets.

# TABLE OF CONTENTS

WELCOME .....	1
GENERAL INFORMATION .....	5
Introduction .....	5
FCC LICENSE AND REGULATION INFORMATION .....	6
Digital Selective Calling (DSC) Capability .....	6
Required License Information .....	6
Equipment Required .....	6
Equipment Supplied .....	7
Optional Equipment .....	7
BASIC RADIO COMMUNICATION PROCEDURES .....	8
Using Channel 16 .....	8
Calling Another Vessel .....	9
Telephone Calls .....	9
Prohibited Communication .....	10
INSTALLATION .....	11
Transceiver .....	11
Antenna .....	11
Power Connection .....	11
NMEA Cable .....	12
External Speaker Connection .....	12
Rear Panel Connectors .....	12
Antenna Connector .....	12
OPERATION .....	13
General .....	13
Display and Controls .....	13
Basic Operation .....	14
Power On/Off .....	14
Volume and Squelch .....	14
Channel Selection .....	15
To receive WX channel .....	15
Return to USA channel from WX channel .....	16
Set up the Canada Channel .....	17
Set up the International channel .....	18
Channel change to USA from Canada or International channel .....	20
Switching of Priority channel .....	21
Channel bank .....	22
Keypad, Transceiver .....	22
Keypad, Microphone .....	23
OPERATING PROCEDURES .....	24
Primary calling channel .....	24
Transmitting .....	24

Working Channel Recall .....	24
Transmitter Power Setting .....	25
Channel Scanning .....	25
Priority Scan .....	26
All Scan .....	26
Memory scan .....	26
Memory Function .....	28
Main Menu Topics .....	29
DIRECTORY .....	29
Lamp .....	32
Contrast .....	33
Data Set .....	33
MMSID Set .....	36
Time Set .....	37
NMEA Set .....	38
DSC OPERATION .....	39
MMSID .....	39
Sending a Distress Call .....	40
Receiving Distress Calls .....	42
Distress sent by another vessel .....	42
Distress ACK sent to another vessel .....	43
Distress Relay from another vessel .....	43
Normal DSC Call .....	44
Individual DSC calls .....	44
Directory Call .....	46
Manual Call .....	47
All Ships Call .....	49
Group Call .....	51
Receiving DSC Calls .....	52
Individual Call Received .....	52
Last Call Received .....	53
All Ships Call Received .....	54
Group Call Received .....	55
REFERENCE .....	56
Maintenance .....	56
Special Functions .....	47
Simulator Mode .....	47
Clear Memory Channels .....	47
New Microphone .....	47
Printer Operation .....	47
Troubleshooting .....	57
Specifications .....	49
Channel Assignments .....	53

## **GENERAL INFORMATION**

Congratulations on your purchase of the *SX 35 DSC*. It is an advanced marine VHF communication transceiver offering Digital Selective Calling, an easy to use four line LCD display, and a separate Channel 70 receiver.

### **NOTICE**

Unauthorized changes or modifications to this equipment may void compliance with Regulatory Agency Type Acceptance. Any changes or modification must be approved in writing by the manufacturer.

### **NOTICE**

This radio transceiver has been tested and complies with FCC regulation. This specification provides reasonable protection against harmful interference in a normal installation. This radio generates, uses and radiates radio frequency energy and, if not installed and used in accordance with the instructions, may cause harmful interference to other marine electronic equipment. However, there is no guarantee that interference will not occur in a particular installation. If this radio does cause harmful interference to marine electronic equipment, which can be determined by turning this radio Off and On, the user is encouraged to try to correct the interference by one or more of the following measures:

- Reorient or relocate the antenna.
- Increase separation between this radio and other marine electronic equipment.
- Connect this radio to a power source different from that of other marine electronic equipment.
- Consult your dealer or an experienced technician for help.

### **Introduction**

Your *SX 35 DSC* VHF Transceiver is designed for operation in the marine VHF FM frequency band.

The transceiver has Digital Selective Calling (DSC). Distress, All Ships, Individual and Group DSC call formats are supported. There are thirty two memories for storing incoming DSC calls and thirty two for your personal DSC call directory.

Other features include all channel scanning, priority channel scanning, memory channel scanning, one button instant access to channel 16 and an alphanumeric keypad on the microphone.

## FCC LICENSE AND REGULATION INFORMATION

The FCC requires some operators to have a ship station license for any vessel on which a radiotelephone is installed. The following procedures should be followed to obtain the ship station license.

1. It is necessary for you to fill out FCC Form 506, an application for ship station license, sign it and mail to FEDERAL COMMUNICATIONS COMMISSION, GETTYSBURG, PENNSYLVANIA 17325.
2. You may operate your VH/FM marine radio under a temporary license Form 506A. You should read FCC Form 506A carefully to determine whether you meet all the requirements for holding a temporary permit. After reading Form 506A, you should sign the form and indicate the date of mailing of Form 506. **DO NOT MAIL THE TEMPORARY PERMIT.**  
Keep it in your possession until notification is received from the FCC that the regular license application has been approved. This temporary form is valid for 60 days.
3. Determine a temporary call sign to be used with the temporary permit, and enter this call sign in the appropriate place on Form 506A.

### Digital Selective Calling (DSC) Capability

You must obtain a nine-digit maritime mobile service identity (MMSI) and program it into the unit before you transmit. To obtain an MMSI, you will be asked to provide certain information about your ship. It is important that you obtain an MMSI because National Coast Guards and other search and rescue (SAR) agencies use this information to help speed search and rescue operations.

### Required License Information

The following information pertaining to your transceiver is necessary if completing a station license application

Output Power ..... 1 Watt (low) and 25 Watts (high)  
Emission ..... 16K0F3E, 16K0G3E  
Frequency Range ..... 156.025 to 162.000 MHz

### Equipment Required

The minimum equipment required for two way voice and DSC VHF radio communication with vessels and shore stations includes:

- VHF radio communication transmitter and receiver designed and approved for marine VHF communication use.

- VHF antenna and connecting cable. Use a good quality unity gain antenna for best range performance.
- Power source suitable for the VHF transmitter and receiver.
- For Digital Selective Calling (DSC) VHF communication radios, connection to a GPS receiver that provides latitude and longitude coordinates and UTC time for distress messages.

### **Equipment Supplied**

- *SX 35 DSC* Marine VHF Transceiver.
- Microphone with alphanumeric keypad.
- Mounting Bracket with knobs.
- Power Cable with in-line fuse (6.3 Amp).
- NMEA Data Cable.

### **Optional Equipment**

- Flush Mounting Kit.



## **BASIC RADIO COMMUNICATION PROCEDURES**

Distress or emergency calls may be made either manually or automatically. Sending distress calls automatically uses the Digital Selective Calling (DSC) functions of your transceiver and requires an operating and properly connected navigation receiver. The following procedures are for sending voice distress messages manually. Sending an automatic distress call is described in the DSC section of this manual.

### **Using Channel 16**

Channel 16 is the Calling and Distress channel. An emergency may be defined as a situation that threatens human life or property. In such situations, make sure your transceiver is turned On and set the channel selector to Channel 16. Then use the following procedure to make a distress call. The total transmission should not exceed 1 minute.

1. Press the microphone Push To Talk button. Speak slowly and clearly into the microphone: "Mayday, Mayday, Mayday, this is your vessel's name, your vessel's name, your vessel's name".
2. Then repeat once: "Mayday, your vessel's name".
3. Continue by reporting your position in latitude and longitude or by reporting your bearing (true or magnetic, specify which) and distance from a prominent or well known landmark, geographic feature or aid to navigation.
4. Explain the nature of your emergency (fire, sinking, collision, grounding, health condition, injury, etc.).
5. Report the kind of assistance you require (fire, medical aid, pumps, etc.).
6. State the number of people aboard and the condition of any injured.
7. Estimate the seaworthiness and condition of your vessel.
8. Describe your vessel: length, type, color and any distinguishing feature.
9. End the message by saying "Over". Release the Push To Talk button and listen for a reply.
10. If there is no reply, repeat the above message procedure. If there is still no response, try another channel.

## **Calling Another Vessel**

Channel 16 may be used to establish initial contact with another vessel. However, its most important use is for voice emergency messages. Channel 16 must be monitored at all times except when engaged in actual communication on another channel. Channel 16 is monitored by international search and rescue (SAR) authorities, National Coast Guards and by other vessels. Use of Channel 16 for calling or hailing must be limited to initial contact only. Calling should not exceed 30 seconds and may be repeated 3 times at 2 minute intervals.

Prior to making contact with another vessel, determine which channel will be used for continued communication after the initial contact. Channels 68 and 72 (see Channel Assignment tables) are two channels available for noncommercial (recreational) communication. Monitor the desired channel for traffic and, when clear, switch to Channel 16 to make initial contact.

Listen for traffic on the Calling Channel (16). If clear, press the Push To Talk (PTT) button on the microphone. Speak the name of the vessel you are calling followed by "this is" and the name of your vessel and your call sign. Release the PTT and listen for a reply. When the other vessel returns your call, acknowledge the call with "go to", the number of the new channel and "over". Switch to the new channel and listen for traffic. If necessary, wait for traffic to clear, and then call the other vessel. As communication proceeds, end each transmission with "over". When communication with the other vessel is completed, end the last transmission with your call sign and the word "out". It is not necessary to end each transmission with your call sign, just give your call sign at the beginning and end of each contact.

Remember to switch to Channel 16 when not actively communicating on another channel.

## **Telephone Calls**

You may use your *SX 35 DSC* transceiver to make telephone calls to persons on shore. To do so requires the services of marine operators who operate on designated Public Correspondence channels. There are several channels designated for this type of traffic and to determine the channel being used in your area, ask someone with local knowledge, contact a Harbor Master or other marine authority.

Call the marine operator and identify yourself with your vessel's name. Normally you contact a marine operator on their working channel rather than making initial contact on Channel 16. The marine operator will ask for your intentions and establish a payment method for the call (collect, credit card, etc.). When arrangements are complete, your radio communication will be patched into the telephone line. In conversing with a person on the phone it is important to use normal radio communication procedures. You should say "over" and release the **PTT** button at the end of each transmission. Both parties cannot speak simultaneously as on normal telephone calls.

Usually there is a fee for marine operator services which is charged in addition to any other charges associated with the call.

### **Prohibited Communication**

The following communications are prohibited by regulations and violators are subject to penalties.

- False distress or emergency messages (including false DSC distress).
- Messages to "any vessel" except in emergencies and radio tests.
- Messages to or from a vessel on land.
- Transmission while on land.
- Obscene, indecent, or profane language.

# INSTALLATION

## Transceiver

Your SX 35 DSC Transceiver is designed to withstand the rigors of the marine environment. However, selecting a mounting location affording some protection from the elements will prolong the life of connectors, controls and the liquid crystal display (LCD).

Select a location within easy reach and view of the operator and away from your vessel's compass. Locate the microphone to avoid entanglement with steering or engine controls, both when in use and when stowed. Also, consider routing of antenna, power and NMEA interface cables. Mount the transceiver securely to a solid surface.

## Antenna

Proper installation of a quality VHF antenna is very important to reliable radio communication. A good quality unity gain antenna is recommended for maximum range performance. In general, antennas should be located as high as practical and separated as much as possible from other antennas and structures. The minimum distance to other objects is 1 meter. Route the antenna cable away from other electronic equipment and do not bundle the antenna or power cable with other wiring, especially transducer cables for depth sounders and fish finders. For cables longer than 10 meters, RG-8/U coaxial cable must be used. Mount the antenna and install the connector(s) in accordance with manufacturers instructions. Connect the antenna cable to the RF output connector on the rear panel of the transceiver.

## Power Connection

---

### CAUTION

**Reverse polarity connections can damage your transceiver**

---

The power cable for you transceiver must be connected to the ships main power buss. Use the 6.3 Amp in-line fuse provided. Connect the Red wire to the positive (+) terminal and the Black wire to the negative (-) terminal. Connect the barrel terminals on the power cable to the matching color wires and terminals extending from the rear panel of the transceiver.

## NMEA Cable

In order for the position reporting features of your SX 35 DSC transceiver to function, an operating GPS navigation receiver must be connected to your transceiver. The supplied data cable plugs into the 8 pin connector on the transceiver's rear panel and the other end connects to the NMEA data output from your GPS navigation receiver. Your GPS must output the \$GPRMC NMEA data sentence. Refer to your navigation receiver manual for information about its NMEA output settings and connections.

## External Speaker Connection

Provision for connecting an external speaker is provided on the rear panel. Use an 8 Ohm speaker rated for at least 3 Watts and suitable for the environment at the chosen location.

## Rear Panel Connectors

### Data Connector (Rear Panel)

1	NMEA Rx (+)	Brown
2	NMEA Rx (-)	Red
3	NMEA Tx (+)	Orange
4	Ground/Tx (-)	Shield
5	Clock	Green
6	Reset	Blue
7	PDI	Gray
8	PDO	Purple



### External Speaker Connector (Rear Panel)

3.5 mm Phone plug

Tip Audio Out (+)  
Body Audio Out (-)

Pins 3 & 4 reserved for DSC/PC printer interface

Pins 5-8 reserved for Flash programmer

## Antenna Connector

The transceiver is fitted with a type SO 239 female connector which mates with a PL 259 male connector supplied with VHF marine antennas.

# OPERATION

## General

Your SX 35 DSC is an advanced marine VHF communication transceiver offering the safety and convenience of Digital Selective Calling in addition to all the useful features found in the best conventional VHF radios.

## Display and Controls

The transceiver is operated using the front panel controls, the keypad, the Push To Talk (PTT) button and a keypad on the microphone. The 4-line LCD displays the current operating status, menus for selecting functions, and settings for optional features. The microphone has a keypad for changing channels and selecting functions.

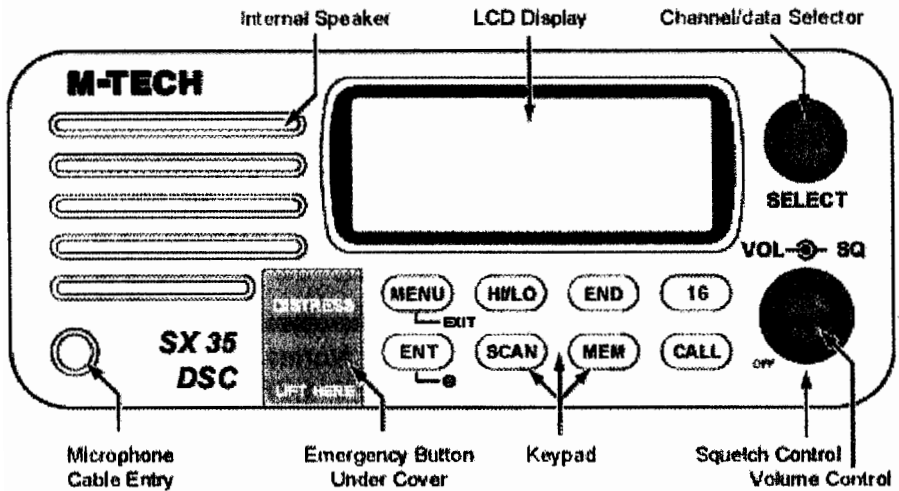

SX 35 DSC

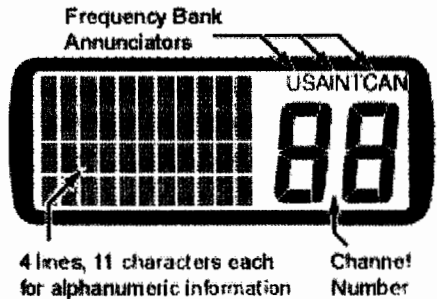
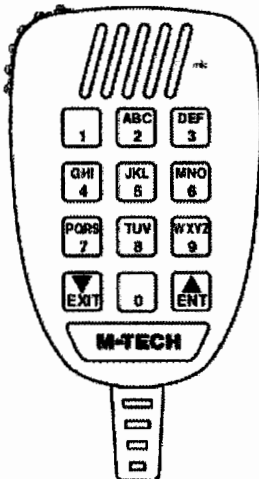

Liquid Crystal Display

## Basic Operation

### Power On/Off

Power to the transceiver is controlled with the **VOL** knob. When the **VOL** knob is in the full CCW position the unit is turned Off.

To turn the transceiver On:

- Rotate the **VOL** knob CW until it clicks over the detent. The LCD back-light illuminates and the Power-On screen appears.

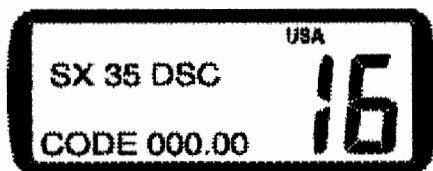

**Power-On Screen**

After approximately two seconds, the Normal Communication screen appears in the display.



**Normal Com Screen  
with GPS Connected**



**Normal Com Screen  
w/o GPS Connected**

To turn the transceiver Off:

- Rotate the **VOL** knob CCW until it clicks over the detent to the OFF position.

### Volume and Squelch

The **VOL** and **SQ** controls have concentric knobs. The outer ring knob controls squelch and the inner knob controls volume. They are independent controls but work together to control audio output from the speaker. The volume control sets the loudness of sound from the speaker and the squelch control is used to mute background noise when no received signals are present.

To properly set the **VOL** and **SQ** controls:





- Rotate the **SQ** control fully CCW.
- Rotate the **VOL** control CW until background noise is plainly heard.
- Slowly rotate the **SQ** control CW until the noise is muted (squelched). Then adjust the control slightly more CW (approximately 1/8 turn). Use care not to set the **SQ** control more CW than necessary or weak signals may not be heard.

Some channels exhibit more background noise than others, so it may be necessary to readjust the squelch setting when changing channels or when scanning.

### Channel Selection

When the transceiver is turned On, USA channel bank and the Primary Calling Channel (channel 16) are selected.

There are three ways to change channels:

- Rotate the **SELECT** knob, press and hold the  or  keys, or directly enter the channel number using the numeric keys on the microphone. The  and  keys will always change channels except when being used to enter or edit a directory page.

### To Receive WX Channel

- Press the  key to display the Main Menu Topics and move the cursor to WX position.



Main Menu Topics

- Press the  key.

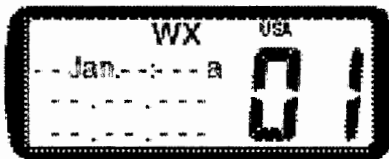

WX Channel Screen



## Return to USA channel from WX channel

There are two ways to return to USA channel.

(e.g. Previously used channel was 72)

- 1) Press the **END** key or **16** key to return to the last used USA channel.

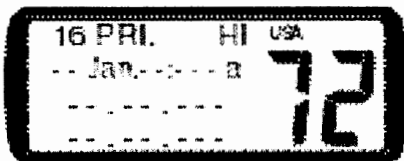

**Normal Com Screen**

Press the **16** key again to return to CH16.

- 2) Press **MENU** key to display the Main Menu Topics and position the cursor to USA using SELECT knob.

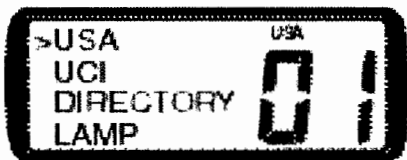

**Main Menu Topics**

Press the **ENT** key.

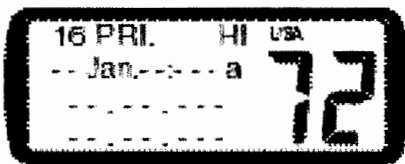

**Normal Com Screen**

## Set up the Canada channels

- Press the **MENU** key to display the Main Menu Topics.



**Main Menu Topics**

- Move the cursor to UIC rotating the SELECT knob clockwise.



**Main Menu Topics**

- Press the **ENT** key.

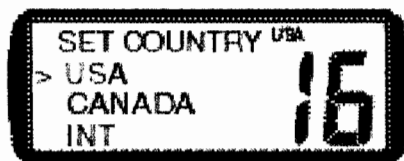

**Country Select Screen**

- Move the cursor to CANADA rotating the SELECT knob clockwise.

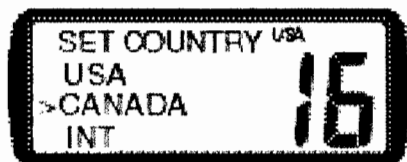

**Country Select Screen**

- Press the **ENT** key.

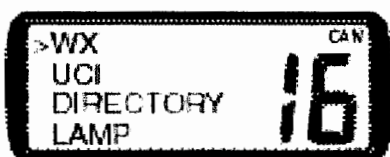

### Main Menu Topics

- Press the **MENU** or **16** key.



### Canada Channel Screen

## Set up the International channel

- Press the **MENU** key to display the Main Menu Topics.

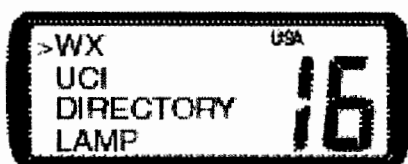

### Main Menu Topics

- Move the cursor to UIC rotating SELECT knob.

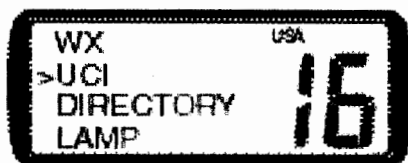

### Main Menu Topics

- Press the **ENT** key.

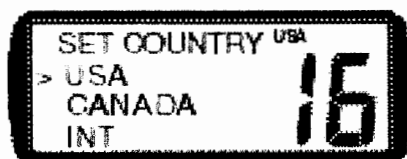

**Country Select Screen**

- Move the cursor to INT rotating SELECT knob.

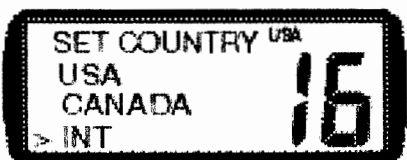

**Country Select Screen**

- Press the **ENT** key.

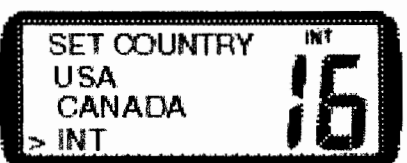

**Main Menu Topics**

- Press the **MENU** or **16** key.



**International Channel Screen**

## Channel change to USA from Canada or International channel

- Press the **MENU** key to display the Main Menu Topics.

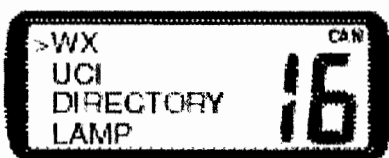

### Main Menu Topics

- 1) Move the cursor to UCI rotating SELECT knob.

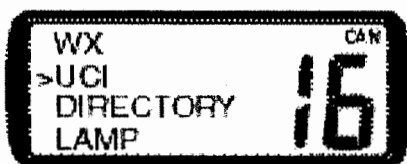

### Main Menu Topics

- 2) Press the **ENT** key.

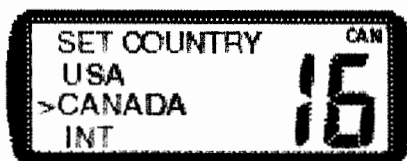

### Country Select Screen

- 3) Move the cursor to USA using SELECT knob.

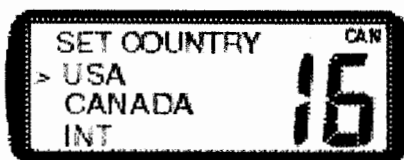

### Country Select Screen

4) Press the **ENT** key.

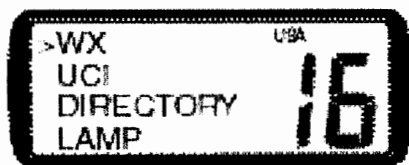

#### Main Menu Topics

5) Press the **MENU** or **16** key.



#### Normal Com Screen

### Switching of Priority channel

1) Press and hold the **16** key when the present priority channel is 16.

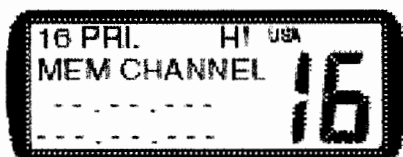

#### Normal Com Screen

Priority channel will be changed to 09.

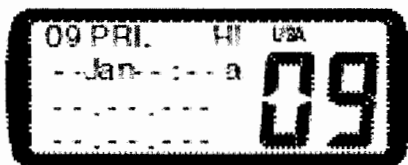

#### Normal Com Screen

2) Press and hold the **16** key when the priority channel is 09.

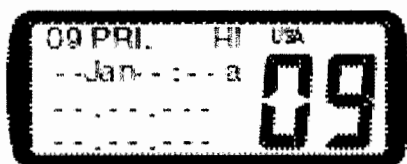

Normal Com Screen

Priority channel will be changed to 16.



Normal Com Screen

### Channel Banks

Your SX 35 DSC is designed for use with USA, Canada, and the International VHF marine channel frequencies plus authorized local channel frequencies. Only authorized dealers can program other approved country channels, where specifically allowed by government regulations, by using the 8 pin com connector.

### Keypad, Transceiver

A tone is emitted each time a key is pressed. A three beep error tone is emitted when a key is not allowed. Some functions require a key to be pressed and held. After the hold period times out, a second tone is emitted as the function is entered. The basic purpose for each key follows. Detailed usage of keys is described in operating procedures for the transceivers various functions.

**MENU** Opens menus to select optional settings to personalize your transceiver's operation.

**H/LO** Use to toggle transmitter power between 25 watts and 1 watt output. Certain channels are restricted to 1 watt maximum power and will cause the error beep if the **H/LO** key is pressed.

- END** Cancels DSC calls and Emergency/Distress calls.
- 16** Selects the Primary Calling Channel 16 or the last channel used. Also, cancels DSC and Emergency/Distress calls.
- ENT** Used to complete editing or selection of options from menus. Use to delete channels in All Scan function.
- SCAN** Can be used alone or with the **MEM** key to select Priority Scan, Memory Scan or All Scan.
- MEM** Stores channels in the scan memory bank, and when used with the **SCAN** key, starts Memory Scan.
- CALL** Initiates DSC operation screens.

### Keypad, Microphone

The microphone keypad is used to change channels by directly entering the actual channel number with the **0** through **9** keys. The **ENT** or **EXIT** keys step or scroll to a new channel. The microphone keys are used to enter alphanumeric characters and symbols shown in the following chart.

<b>Microphone Keys</b>									
<b>0</b>	<b>1</b>	<b>ABC</b>	<b>DEF</b>	<b>GHI</b>	<b>JKL</b>	<b>MNO</b>	<b>PQRS</b>	<b>TUV</b>	<b>WXYZ</b>
<b>Alphanumeric Character Sequence</b>									
<b>0</b>	<b>1</b>	<b>A</b>	<b>D</b>	<b>G</b>	<b>J</b>	<b>M</b>	<b>P</b>	<b>T</b>	<b>W</b>
<b>Space</b>	<b>-</b>	<b>B</b>	<b>E</b>	<b>H</b>	<b>K</b>	<b>N</b>	<b>Q</b>	<b>U</b>	<b>X</b>
<b>(</b>	<b>,</b>	<b>C</b>	<b>F</b>	<b>I</b>	<b>L</b>	<b>O</b>	<b>R</b>	<b>V</b>	<b>Y</b>
<b>)</b>	<b>.</b>	<b>?</b>	<b>'</b>	<b>:</b>	<b>#</b>	<b>'</b>	<b>S</b>	<b>&amp;</b>	<b>Z</b>
<b>%</b>	<b>/</b>	<b>2</b>	<b>3</b>	<b>4</b>	<b>5</b>	<b>6</b>	<b>7</b>	<b>8</b>	<b>9</b>



# OPERATING PROCEDURES

## Primary Calling Channel

VHF Channel 16 (156.8 MHz) is the Distress Safety and Primary Calling Channel. All vessels, not actively engaged in communication, are required to maintain a listening watch on Channel 16.

## Transmitting

The transmitter is activated, for normal voice communications, by pressing the Push To Talk (**PTT**) button on the microphone. Always listen for moment on a channel before transmitting. If the channel is busy, do not transmit until the channel is clear. For DSC calling and Distress calls, the transmitter is activated automatically during the appropriate operating procedure. After DSC contact is established, proceed as in normal voice communication. Continuous transmitter operation is limited to five minutes and the transmitter will automatically stop.

To establish normal voice communication:

- Press the **16** key to select the Primary Calling Channel. The Primary Calling Channel is 16. The Primary Calling Channel number appears in the upper left corner of the display.
- Listen on the Primary Calling Channel to make sure the channel is clear.
- Press the **PTT** button. Speak directly into the microphone in a normal tone of voice—clearly—distinctly. Say “(name of vessel being called) THIS IS (your vessel’s name and call sign).”
- Release the **PTT** button and listen for a reply.
- Once contact is made on the Primary Calling Channel, each vessel must switch to a working channel to continue conversation. Refer to the channel chart for proper usage.
- After communication is completed, each vessel must give its call sign or vessel name and switch to the Primary Calling Channel and resume listening watch.
- The transmitter will automatically be turned off after five minutes (except Public channels) and the receiver is put in action. At the same time, a beeping sound is heard from the speaker.

## Working Channel Recall

Rather than using the **SELECT** knob or microphone keys to change channels,

this feature allows quick switching between the last working channel and the current primary channel.

To quickly switch between the last working channel and the Primary Calling Channel:

- Use the **SELECT** knob or microphone keys to select a working channel, such as channel 68.
- Press the **16** key momentarily. The current primary channel number appears in the channel number display.
- Press the **16** key again momentarily. The working channel number appears in the display. Each time the key is pressed, channel selection toggles between the primary channel and the working channel.

### Transmitter Power Setting

The transmitter has two power settings, 25 watts or 1 watt, which are indicated by **HI** or **LO** appearing in the upper line of the display. The normal power setting is **HI** for all channels where 25 watts is allowed. Use the 1 watt setting for communication with nearby vessels (bridge-to-bridge) or facilities (drawbridges).

- Press the **HI/LO** key to toggle transmitter power between 25 watts and 1 watt output.

---

### SPECIAL NOTE

USA channels 13, 17, 67 Int'l channels 15, 17, 75, 76 and Canadian channels 15, 17 are automatically set to 1W low power when they are selected. 25W high power for channels 13, 67 USA channels is available by pressing the HI/LO key during transmitting. The transmitter will not operate on channels 15 USA channel and on weather channels.

---

### Channel Scanning

There are three channel scanning modes; Priority Scan, All Scan and Memory Scan. In the Priority Scan mode, Channel 16 is checked for activity every 2 seconds, even if, the scan is halted by traffic on a working channel. When scanning is halted by traffic, the scan pauses while the channel is active. Scanning resumes, after a brief delay when the channel is clear. If the **PTT** is pressed, in reply to a received signal, scanning is cancelled.

## Priority Scan

The Priority Scan function scans the Primary Calling Channel and the last selected working channel.

To select Priority Scan:

- Press the **(SCAN)** key. **PSCAN** appears in the upper line of the display and the two scanned channel numbers appear alternately in the display.



### Priority Scan Sequence

To exit Priority Scan:

- Press the **(SCAN)** key or press the **(16)** key.

## All Scan

The All Scan function scans all channels except channel 70. Channel 70 is the Digital Selective Calling (DSC) channel. Voice traffic is not permitted on this channel. If noisy or busy channels interfere with scanning, the interfering channels may be temporarily removed from the scan sequence.

To select All Scan:

- Press and hold the **(SCAN)** key for 2 seconds. **ALLSCAN** appears in the upper line of the display. The scanned channel numbers appear in sequence in the channel number display.

To Exit All Scan:

- Press the **(SCAN)** key or press the **(16)** key.

To delete channels from the scan sequence:

- Press and hold the **(ENT)** key while the scan is halted on the offending channel. Turning the transceiver Off and On, restores all channels to the scan sequence.

## Memory Scan

Memory Scan allows the user to create and scan a bank of preferred channels.

Channels may be added to or removed from the memory channel bank as desired. Memory channels are stored individually and may be deleted individually, or the entire bank may be deleted. If the **PTT** button is pressed, the transceiver exits scanning and normal communication is resumed.

To create or add channels to the memory channel bank:

- Press the **MEM** key. The Memory Scan channel bank appears in lower two lines of the display. If no channels have been previously added to the bank, the Primary Calling Channel (16) is displayed. Otherwise, up to six channel numbers appear. A plus sign (+) at the end of the lower line indicates more than six channels are stored in the bank. Press the **MEM** key again to advance to the next page of channels. The memory channel bank can hold all usable voice communication channels.



**Memory Scan Bank  
Default Page**

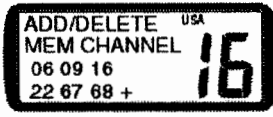

**Memory Scan Bank  
Page Full**



**Memory Scan Bank  
Next Page**

- Rotate the **SELECT** knob or microphone keys to select a desired channel to add to the memory channel bank.
- Press and hold the **MEM** key for about two seconds. The selected channel is stored and the channel number appears in the memory channel bank. Repeat the select and store process to add more preferred channels. As each channel is added, the existing channels in the bank shift as necessary to display the new channel number in the bank.

When in the normal communication mode, as channels are selected, **MEM CHANNEL** appears in the second line of the display if the selected channel is stored as a memory channel.



**Memory channel Display**

To remove channels from the memory channel bank:

- Press the **MEM** key. The Memory Scan channels appear in the display.
- Rotate the **SELECT** knob or use microphone keys to select a displayed channel.
- Press and hold the **MEM** key for about two seconds. The selected channel is deleted and the channel number is removed from the memory channel bank.

To remove all channels from the memory channel bank:

- Turn the transceiver Off.
- Press and hold the **MEM** key while turning the transceiver On. The memory channel bank is erased except for Channel 16 which remains.

To start Memory Scan:

- Press the **MEM** key. The Memory Scan channel bank appears in the display.
- Press the **SCAN** key. **MSCAN** appears in the upper line of the display. The scanned channel numbers appear in sequence in the channel number display.

## Menu Functions

Menus are used to customize optional settings to individual preference. The multilevel menu system is a list of topics that, when selected individually, offer options or additional related topics from which to choose. Changes to menu settings are stored and remain in force until changed again.

To navigate through menus:

- Press the **MENU** key. The Main Menu appears in the display. **DIRECTORY** is always the first topic displayed on the Main Menu list.

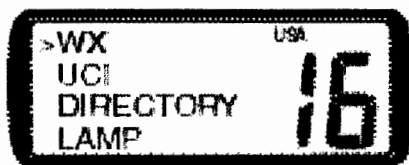

Main Menu Topics

To select a topic in the menu list:

- Rotate the **SELECT** knob to move the cursor > to the desired topic. There are more topics than can be displayed at one time, so the list scrolls as the cursor is advanced beyond the top or bottom of the list.



### More Main Menu Topics

- With the cursor on the desired menu topic, press the **ENT** key. Options or edit settings for the topic appear in the display.
- Use the **SELECT** knob to move the cursor to the desired setting.
- Press the **ENT** key to store the new setting.

If you change your mind:

- Before pressing the **ENT** key while in an editing mode, press the **MENU** key to backup to the next higher menu level.

To exit the menus and return to communication functions:

- Press the **16** key. If the **ENT** key was not pressed to store a new value, no changes are made.

## Main Menu Topics

### DIRECTORY

The DSC Calling Directory is a list of names and corresponding MMSID's that you enter and store for making DSC calls (32 ID's maximum). Entries to the list can be added or edited as necessary to keep your directory current.

To add a name and MMSID to the directory:

- Press the **MENU** key. The **DIRECTORY** topic appears in the display.
- Press the **ENT** key. If the directory is empty, the screen appears blank except for the channel number. If previous entries appear, move the cursor to an empty line. If no empty line is found, the directory is full and a previous entry must be overwritten.

- Press the **ENT** key. The **DIRECTORY NAME/ID** screen appears with a blinking cursor next to the name line.

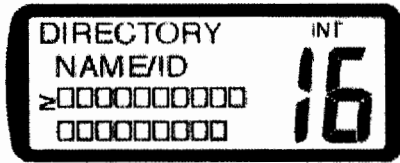

### Name and ID Screen

- Press the **ENT** or **ENT** key to move the cursor to the first character of the name line.

### SPECIAL NOTE

Characters are entered in the name and ID fields using either the **SELECT** knob or the microphone keys.

All letters in the alphabet, a space, and the numbers 0~9, plus punctuation marks and some symbols may be used. The space character follows Z in the alphabet when using the **SELECT** knob. Only numbers are allowed in the ID field.

The following table shows the characters that may be entered in the name field using the microphone keys.

Microphone Keys									
0	1	ABC	DEF	GHI	JKL	MNO	PQRS	TUV	WXYZ
0	1	2	3	4	5	6	7	8	9
Alphanumeric Character Sequence									
0	1	A	D	G	J	M	P	T	W
Space	-	B	E	H	K	N	Q	U	X
(	,	C	F	I	L	O	R	V	Y
)	.	?	!	:	#	'	&	&	Z
%	/	2	3	4	5	6	7	8	9

Several additional special characters are available when entering the name using the **SELECT** knob.

- Use the **SELECT** knob or microphone keys to select the desired letter, number or symbol for the first character.
- If using the **SELECT** knob, press the **ENT** or **ENT** key after each charac-

ter is selected to enter the character and advance the cursor to the next character position.

- If using the microphone keys, press the appropriate key repeatedly until the desired character is displayed at the cursor position. Then press the appropriate key for the next character. The cursor automatically moves to the new position. When entering the same character in two or more successive character positions, use the **ENT** or **ENT** keys to advance the cursor.
- Use the **EXIT** key if necessary to backspace the cursor.
- Up to ten characters are allowed in the name, but only one is required. Enter enough characters to positively identify the entry.
- After the last character in the name is selected and entered, press the **ENT** or **ENT** key again. The cursor moves to the MMSID line.
- Press the **ENT** or **ENT** key to move the cursor to the first digit position in the MMSID line.
- Enter the first number in the MMSID. Only numbers 0~9 are allowed in the MMSID.
- Press the next microphone number key or press the **ENT** key to store the selected digit and move the cursor to the next digit position.
- Continue to select and store digits until the complete MMSID is entered. After the last MMSID digit is entered, the cursor returns to the name line of the display.
- If the name and ID are correct for this directory entry, press the **MENU** key to save the data and exit. The directory list appears in the display showing the new entry by name only. The MMSID does not appear in the directory list.

To edit an existing name or MMSID in the directory:

- Press the **MENU** key. The **DIRECTORY** topic appears in the display.
- Press the **ENT** key. DSC Calling Directory entries appear in the display. The directory stores a maximum of 32 entries which are displayed four at a time.
- Use the **SELECT** knob to move the cursor to the entry name for editing.
- Press the **ENT** key. The **DIRECTORY NAME/ID** screen appears present-



ing the name and MMSID for the selected directory entry. The blinking cursor is positioned at the start of the entry's name.

- Press the **ENT** or **ENT** key. The cursor becomes an underline instead of a blinking square and moves to the first character position.
- Use the **SELECT** knob to move the underline cursor to the character position needing change.
- Press the **ENT** or **ENT** key. The blinking cursor appears.
- Use the **SELECT** knob or microphone keys to change the contents of the character to the new value.
- When new value is correct, press the **ENT** key or the **ENT** key. If more characters in the same line need changing, use the **ENT** or **ENT** or **EXIT** key to move the blinking cursor to the next desired character. If no more changes are desired on the same line, use the **MENU** key to move the cursor back to the start of the line.
- When both the name and MMSID are correct, press the **MENU** key to save the data and exit to the directory listing.

## LAMP

Allows adjustment of illumination for the LCD display, keypad and microphone keypad.

- Press the **MENU** key. Menu topics appear in the display.
- Use the **SELECT** knob to position the cursor on the **LAMP** topic.
- Press the **ENT** key. The **BRIGHTNESS** adjust screen appears in the display.

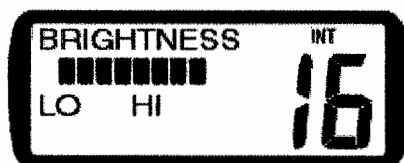

**Brightness Control**

- Use the **SELECT** knob or microphone keys 0~3 to change the setting.
- Press the **ENT** or **MENU** key to store the setting and exit.

### CONTRAST

Allows adjustment of LCD display contrast for best readability in varying lighting conditions.

- Press the **MENU** key. Menu topics appear in the display.
- Use the **SELECT** knob to position the cursor on the **CONTRAST** topic.
- Press the **ENT** key. The **CONTRAST** adjust screen appears in the display.

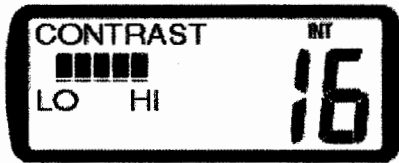

#### Contrast Control

- Use the **SELECT** knob or microphone keys 0~7 to change the setting.
- Press the **ENT** or **MENU** key to store the setting and exit.

### DATA SET

Provides On/Off control for display of Lat/Lon, Date/Time, Speed/Course, and Manual Lat/Lon. Also, provides for entry of Manual Lat/Lon coordinates.

- Press the **MENU** key. Menu topics appear in the display.
- Use the **SELECT** knob to position the cursor on the **DATA SET** topic.
- Press the **ENT** key. The Data Set menu selections appear in the display.

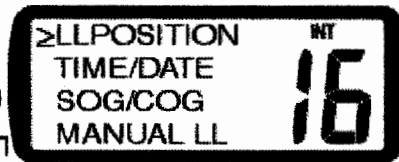

- Press the **ENT** key.
- Use the **SELECT** knob to select either On or Off.

#### Data Set Selections

- Use the **SELECT** knob or **ENT** or **EXIT** to select either LLPOSITION,

**TIME/DATE** or **SOG/COG**. **MANUAL LL** is described separately.

- Press the **ENT** key to store the selection and exit to the previous menu.
- Use the **SELECT** knob or any microphone key to select either On or Off.

The **MANUAL LL** data item has 3 options, On/Off/Set. The Set option is used to manually enter your approximate Lat/Lon position and time of day for distress messages if your GPS is not connected or not functioning. If Manual Lat/Lon is turned On, it overrides your GPS Lat/Lon position. Be sure Manual Lat/Lon and time of day are correctly entered before turning the function On. Time of day is entered as your local time in either 12 hour or 24 hour format. Its is important that your local time offset from Universal Coordinated Time (UTC) is set correctly. See the **TIME SET** topic on the Main Menu.

To set Manual Lat/Lon:

- Press the **MENU** key. Menu topics appear in the display.
- Use the **SELECT** knob to position the cursor on the **DATA SET** topic.
- Press the **ENT** key. The Data Set menu selections appear in the display.

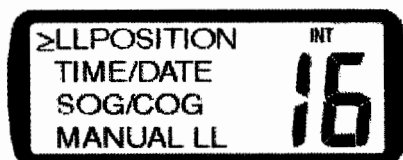

#### Data Set Selections

- Use the **SELECT** knob or **ENT** or **EXIT** to select **MANUAL LL**.
- Press the **ENT** key. The **MANUAL LL** menu appears in the display.

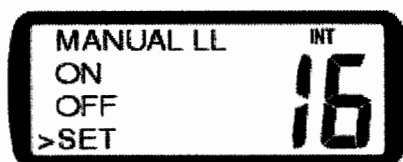

#### Manual LL Menu

- Use the **SELECT** knob to select **SET** on the menu.

- Press the **ENT** key. The **SET LL/TIME** screen appears.

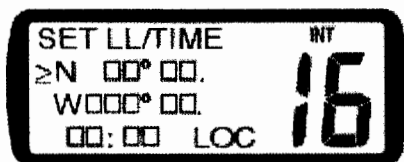

### Manual LL Entry

- Press the **ENT** or **ENT** key to place the blinking cursor on the first character (**N** or **S**) in the Latitude entry line.
- Use the **EXIT** key to toggle **N** or **S** to select a hemisphere (North or South) designator.
- Press **ENT** or **ENT** to move the blinking cursor to the next character in the Latitude entry.
- Use the **SELECT** knob or the microphone keys 0~9 to enter the correct Latitude value in degrees and minutes. When Latitude is complete, the cursor moves to the Longitude line.
- Press the **ENT** or **ENT** key to place the blinking cursor on the first character (**E** or **W**) in the Longitude entry line.
- Use the **EXIT** key to toggle **E** or **W** to select a hemisphere (East or West) designator.
- Press **ENT** or **ENT** to move the blinking cursor to the next character in the Longitude entry.
- Use the **SELECT** knob or the microphone keys 0~9 to enter the correct Longitude value in degrees and minutes. When Longitude is complete, the cursor moves to the Time entry line.
- Press **ENT** or **ENT** to move the blinking cursor to the first character in the Time entry.
- Use the **SELECT** knob or the microphone keys 0~9 to enter the correct time of day. **LOC** appears at the end of the Time line indicating entry must be local time.

- Enter your local time in hours and minutes. Use 12 hour AM/PM format if **a** or **p** appear after the minutes characters. The **SELECT** knob or the microphone keys 0~9 toggle the **a/p** setting. If neither **a** or **p** appear in the Time line, enter your local time, hours and minutes, in 24 hour format.
- When Lat/Lon and Time values are correct, press the **(MENU)** key to return to the **MANUAL LL** menu page.

To turn Manual Lat/Lon On or Off:

- Use the **SELECT** knob to select either On or Off on the **MANUAL LL** page.
- Press the **(ENT)** key to store the selection.
- Press the **(16)** key. The Main display appears. If Manual Lat/Lon is turned On, and manually entered values are stored, the Lat/Lon values appear in the lower two lines of the display. The **M** appearing at the end of the Longitude line indicates that Manual Lat/Lon is turned On. When Manual Lat/Lon is turned On, the manually entered position overrides any Lat/Lon position from a navigation receiver.

## MMSID SET

Provides for entry of the 9 digit MMSI for your vessel which must be entered in order to make DSC calls. MMSI must be obtained from government communication authorities or authorized agents.

---

### CAUTION NOTE

Only one entry attempt is permitted. A warning is displayed after the first attempt and MMSID entry is blocked. CALL YOUR DEALER FOR ASSISTANCE.

---

To enter your MMSI number:

- Press the **(MENU)** key. Menu topics appear in the display.
- Use the **SELECT** knob to position the cursor on the **MMSID SET** topic.
- Press the **(ENT)** key. The **MMSID TYPE** menu appears in the display.

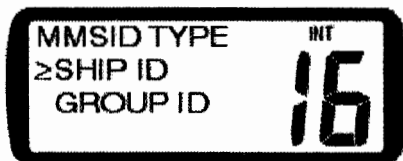

**MMSID Type Select**

- Use the **SELECT** knob to select **SHIP ID** on the menu.
- Press the **ENT** key. The **MMSID SET** screen appears in the display.

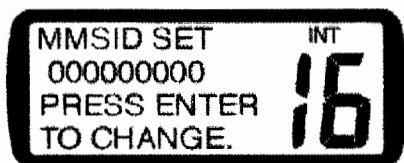

### MMSID Set Screen

- Press the **ENT** key. The blinking cursor appears at the first digit position.
- Use the **SELECT** knob or the microphone keys 0~9 to enter your official MMSI number.
- When the last digit is selected, press the **ENT** or **ENT** key.
- Press the **ENT** or **ENT** key again. **STORED OK** appears briefly in the lower line of the display completing the entry.
- Press the **16** key to return to the Main display.

Follow the above procedure to enter your Group ID number. Group ID entry attempts are not limited in number.

### TIME SET

Allows selection of either 12 or 24 hour time format and provides entry of local time offset from Universal Coordinated Time (UTC), sometimes called Greenwich Mean Time (GMT). UTC is the time at the Prime Meridian, or zero degrees (0°) Longitude which passes through Greenwich, England.

- Press the **MENU** key. Menu topics appear in the display.
- Use the **SELECT** knob to position the cursor on the **TIME SET** topic.
- Press the **ENT** key. The **TIME FORMAT** menu appears in the display.

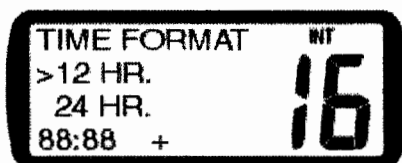

### Format Selection

- Use the **SELECT** knob to select the desired format, either **12 HR** or **24 HR**.
- Press the **(ENT)** key. The **TIME OFFSET** menu appears in the display.

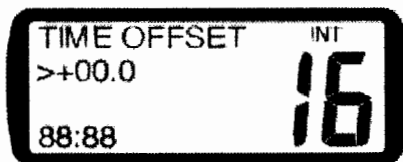

### Time Offset Selection

- Use the **SELECT** knob to set the time difference from the Prime Meridian to your location. If you are West of the Prime Meridian, select a negative (–) value. If you are East of the Prime Meridian, select a positive (+) value. Time offset values from 0 to 12 hours plus or minus may be entered in 1/2 hour increments. Obtain the time offset value from your GPS navigator.
- When your selection is complete, press the **(ENT)** key to store the setting and exit the menu.

### NMEA SET

Allows NMEA sentences from navigation equipment manufactured to earlier versions of the NMEA standard to provide Lat/Lon position coordinates and UTC time.

- Press the **(MENU)** key. Menu topics appear in the display.
- Use the **SELECT** knob to position the cursor on the **NMEA SET** topic.
- Press the **(ENT)** key. The **NMEA CHECKSUM** menu appears in the display.

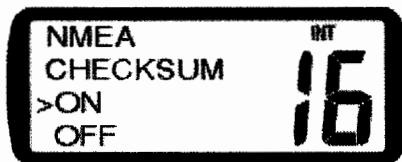

### NMEA Checksum Selection

- Use the **SELECT** knob to select either **ON** or **OFF**.
- When your selection is complete, press the **(ENT)** key to store the setting and exit the menu.

## DSC OPERATION

The Digital Selective Calling (DSC) functions of your *SX 35 DSC* transceiver add convenience and safety to your VHF communication capability. DSC allows you to contact other DSC equipped vessels and shore stations by selecting their names from your personal call directory, choosing a call type, and pressing a key. In an emergency, pressing one button will send your vessel ID and current position to search and rescue (SAR) authorities and other DSC equipped vessels. Distress calls are covered first. Then, normal calling procedures are described.

Position reporting requires connection to an operating GPS navigation receiver or manually entered Lat/Lon coordinates. If data from your GPS is lost, 3 quick error beeps are sounded and the following warning screen appears in the display after 23.5 hours.

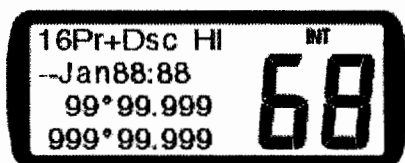

### Set Manual Lat/Lon

This warning screen reminds you to manually enter Lat/Lon coordinates. The old GPS coordinates are used for 23.5 hours if manual coordinates are not entered. See the **MANUAL LL** item of the **DATA SET** topic of the Main Menu.

## MMSID

---

### SPECIAL NOTE

**In order to use DSC functions, you must obtain a nine-digit maritime mobile service identity (MMSI) and program it into your transceiver before you transmit.**

---

Prior to obtaining an MMSI, you will be asked to provide certain information about your vessel and communication equipment. Contact the government radio communication authorities of your country for licensing and MMSI information. It is important that you obtain an MMSI, because National Coast Guard authorities use this information to help speed search and rescue operations.

The procedure for entering your MMSI is described in the MMSID Set topic of the Operating Procedures section.



## Sending a Distress Call

To make a distress call:

- Lift the red protective cover, then press and release the red button. The distress alert screen appears.

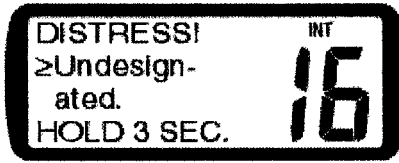

**Distress Alert Screen**

- If time permits, use the **SELECT** knob to select the nature of distress. Otherwise, hold the red button (as soon as the button is pressed again, an intermittent acoustic alarm is sounded and the distress alert screen flashes until the **DISTRESS** is sent automatically, in about 3 seconds). Before the distress is sent, you may release the red button to reset the countdown timer. When the distress is sent, the sending distress call screen appears. The acoustic alarm goes steady-on and remains on until an acknowledgment is received or the acoustic alarm is cancelled.

Nature of Distress		
Undesignated.	Fire or Explosion.	Flooding.
Collision.	Grounding.	Listing or Capsizing.
Sinking.	Disabled & Adrift.	Abandoning Ship.
Piracy Attack.	Man Overboard.	EPRIB Emission.

- After selecting a nature of distress message, press and hold the red button. The actions above are repeated.
- An alarm sounds and the following screen appears as your distress message is being transmitted.



### Sending Distress Call

- The following screen appears indicating your distress message has been transmitted.

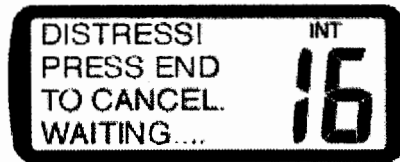

### Distress Call Sent

The DSC distress message is automatically sent on channel 70 and your transceiver is automatically set to Channel 16 in order to listen for, and respond to, voice replies from SAR authorities or other vessels which may have received your distress call. The alarm will sound every 2 minutes to remind you that a distress message is active. Unless canceled, the distress message is automatically retransmitted every 3 1/2 to 4 1/2 minutes.

Re-transmissions of DSC distress calls are canceled automatically when a DSC acknowledgment is received from an authorized SAR coast station, or canceled manually by you.

To manually cancel DSC distress retransmissions from your vessel:

- Press the **END** key. The **DISTRESS CANCELED** message appears in the display.

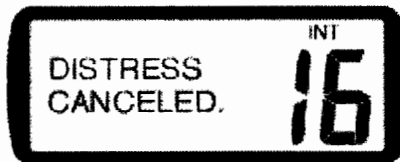

### Manual Distress Cancel

- If your DSC distress call is acknowledged (ACK) by a coast station, the **DISTRESS! CANCELED. ACK RECEIVE** screen appears in the display.

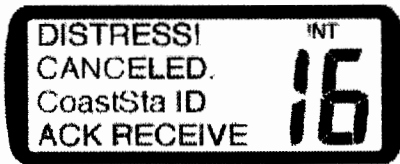

### Distress Acknowledged

- Establish voice contact with the coast station on Channel 16.

### Receiving Distress Calls

Your SX 35 DSC transceiver may intercept distress messages sent by another vessel and/or acknowledgments (ACK) sent by a coast station to another vessel in distress. In such cases you should maintain a listening watch on channel 16 and standby to lend assistance. Your SX 35 DSC does not automatically reply to, or relay, distress or ACK or relay DSC calls.

#### Distress sent by another vessel

If your SX 35 DSC transceiver intercepts a distress call from another vessel, an alarm sounds and the following screen appears in the display.



### Distress Alert, page 1

The screen presents, time of distress, MMSID of the distressed vessel, and Lat/Lon coordinates. The plus sign (+) indicates there is another page of information available. If invalid GPS or Time data is received, the Lat/Lon position shows '9' in all digits and the time shows all '8's.

- Press the **ENT** key to toggle between page 1 and page 2.

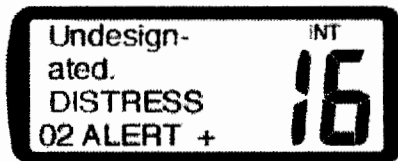

### Distress Alert, page 2

The nature of distress and ALERT call type appear on the second page.

## Distress ACK sent to another vessel

If your SX 35 DSC transceiver intercepts a distress ACK from a coast station, an alarm sounds and the following screen appears in the display.

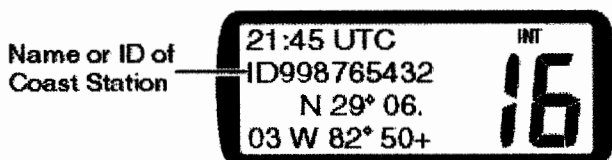

### Coast Station ACK to other vessel, page 1

The screen presents time of ACK and Lat/Lon coordinates. The plus sign (+) indicates there is another page of information available.

- Press the **(ENT)** key to toggle between page 1 and page 2.



### Coast Station ACK to other vessel, page 2

The distressed vessel's MMSID and **ACK** appear on the second page. Maintain a listening watch on channel 16 and standby to lend assistance.

## Distress Relay from another vessel

If your SX 35 DSC transceiver intercepts a distress relay from another vessel, an alarm sounds and the following screen appears in the display.

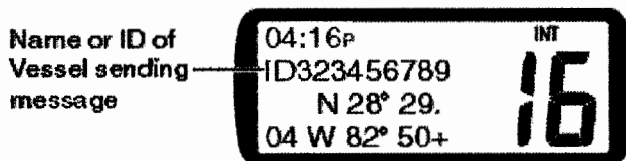

### Distress Relay, page 1

The screen displays, local time of distress, the MMSID of the vessel sending the relay message and Lat/Lon coordinates of the vessel in distress. The plus sign (+) indicates there is another page of information available.

- Press the **(ENT)** key to toggle between page 1 and page 2.



### Distress Relay, page 2

The distressed vessel's MMSID and **RELAY** call type appear on the second page.

Your vessel does not re-send a distress relay message.

### Normal DSC Calls

Your SX 35 DSC can transmit four types of DSC calls; Distress, All Ship's, Individual, and Group. Except for Distress, each call type is subdivided into one or more priorities.

All Ship's type transmits two priorities: Urgency and Safety.

Individual type transmits one priority: Routine.

Group type transmits one priority: Routine.

A normal DSC call may be originated from your vessel to another DSC equipped vessel or to a coast station, or you may reply to a DSC call sent by another vessel or a coast station. Outgoing calls are made either by selecting a vessel or station name from your directory or by manually entering the vessel or station MMSID number.

Replies to any incoming call type can be made directly from the call log. The call log (LAST CALL) holds thirty two entries and the last call received is on top of the list. If the call log is full, the oldest entry is lost.

### Individual DSC Call

Individual calls can be made to another vessel. When calling another vessel, the communication channel is specified in the call by the calling vessel. Your SX 35 DSC transceiver transmits Routine individual calls, but receives both Routine and Safety individual calls.

- Press the **CALL** key to display the DSC calling Menu.

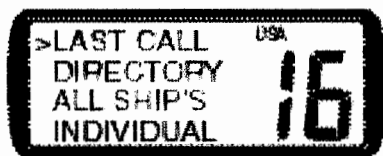

DSC Calling Menu Screen

- Move the cursor to INDIVIDUAL position rotating the SELECT knob.



**DSC Calling Screen**

- Press the **CALL** key and set the channel.



**Individual Screen**

- Set the MMSID of an Individual all. Use the SELECT knob or numeral keys of the microphone to enter the MMSD number to the bottom line.

**CAUTION NOTE:** Only one entry attempt is permitted.



**Individual Screen**

- Press the **CALL** key

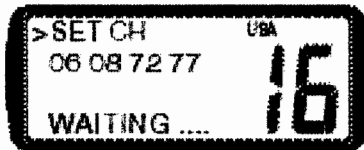

**All Ship's Call Screen**

## Directory Call

Directory calls are made by selecting a vessel or station name from the calling directory. The calling directory holds thirty two of your previously entered names that you routinely contact during normal boating activities.

To make a directory call:

- Press the **CALL** key. The DSC calling menu appears in the display.
- Use the **SELECT** knob to select the **DIRECTORY** topic.



### DSC Directory

- Press the **CALL** key. The directory list appears in the display.
- Use the **SELECT** knob to select the desired vessel name. Note: The MMSID's for each entry do not appear in the list.
- Use the microphone keys to select a working channel.
- Press the **CALL** key. The **INDIVIDUAL** call screen appears in the display.

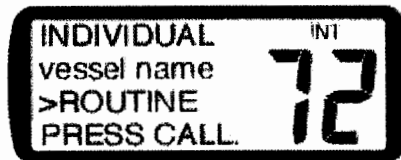

### Individual Call Screen

- Press the **CALL** key to send the call. DSC calls are made on channel 70. If you observe the display closely, you will see the channel number change to channel 70 momentarily and then revert to the selected working channel.
- While waiting for acknowledgment from the called vessel, **WAITING . . . .** appears in the lower line of the display.

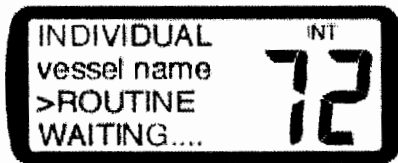

### Waiting For Acknowledge

- When the called vessel acknowledges your call, an alert sounds and **ACK RECEIVE** appears in the lower line of the display.



### Acknowledge Received

- Press the **PTT** button on the microphone to silence the alert and begin voice communication with the called vessel.
- The **(END)** key may be used to exit the DSC calling procedure at any time prior to sending the call.

## Manual Call

The manual call procedure is used to make a DSC call to a vessel or station that is not listed in your calling directory. However, you must know the MMSID for the vessel or station.

To make a manual DSC call:

- Press the **(CALL)** key. The DSC calling menu appears in the display.
- Use the **SELECT** knob to select the **INDIVIDUAL** topic on the menu.

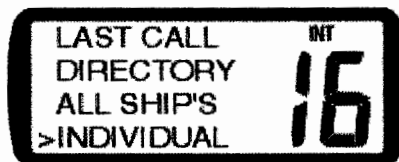

### DSC Manual Call



- Press the **CALL** key. **SELECT CALL** menu appears in the display.



**Select Call**

- Use the **SELECT** knob to select either **VESEL** or **STATION**.
- Press the **CALL** key. The **SET CH**annel/**SET MMSID** screen for vessel and **SET MMSID** screen for station appear in the display respectively.

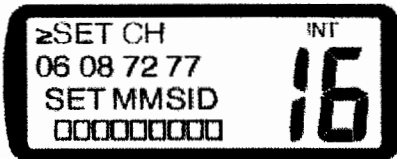

**Set Channel/Set MMSID (VESSEL)**



**Set MMSID (STATION)**

- Use the **SELECT** knob or microphone keys to select a working channel. Four channel numbers appear in the display as suggested channels authorized for the call to vessel. Other channels may be used if authorized in your area. No channel number appears for the call to station.
- Press the **ENT** key. The blinking cursor moves to the first digit in the MMSID entry field. The last used manual MMSID is displayed.
- Use the **SELECT** knob or microphone keys to change the MMSID for the vessel or station to call.
- When the MMSID is correct, press the **CALL** key to send the call. DSC calls are made on channel 70. If you observe the display closely, you will see the channel number change to channel 70 momentarily and then revert to the selected working channel.
- While waiting for acknowledgment from the called vessel or station, **WAITING . . . .** appears in the lower line of the display.

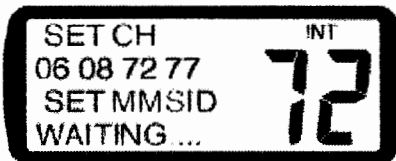

**Waiting For Acknowledge (VESSEL)**

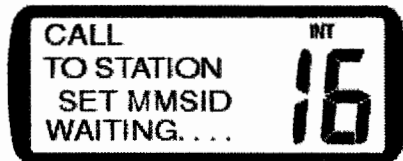

**Waiting For Acknowledge (STATION)**

- When the called vessel or station acknowledge your call, an alert sounds and **ACK RECEIVE** appears in the lower line of the display.



Acknowledge Received (VESSEL)



Acknowledge Received (STATION)

- Press the **PTT** button on the microphone to silence the alert and begin voice communication with the called vessel or station.
- The **END** key may be used to exit the DSC calling procedure at any time prior to sending the call.

### All Ships Call

The All Ship's call allows you to send an Urgent or Safety DSC call to nearby vessels without having to know their MMSID numbers. The All Ship's call may be used in situations that are serious but do not warrant a distress call, and voice communication attempts have failed.

To send an All Ship's call:

- Press the **CALL** key to display the DSC Calling Screen



DSC Calling Screen

- Move the cursor to ALL SHIP'S rotating the SELECT knob.



DSC Calling Screen

- Press the **CALL** key

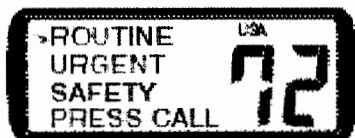

All Ship's Call Screen

- Select the **ROUTINE**, **URGENT** or **SAFETY** using SELECT knob.  
(Selecting **SAFETY** for example)

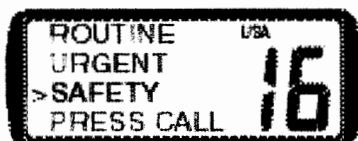

All Ship's Call Screen

- Press the **CALL** key to send the call. The **ALL SHIP'S WAITING . . . .** screen appears in the display. Either **URGENT** or **SAFETY** appear to indicate priority of the call.

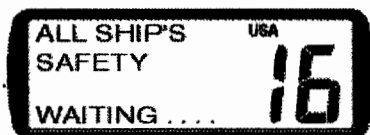

Waiting For Voice Reply

- Your transceiver is automatically set to Channel 16. Listen for voice replies from vessels which have received your call. There is no DSC ACK reply to confirm that your call was received.
- Use the **PTT** button to continue voice communication. The Normal Communication screen appears in the display.
- If there is no response to your call, press the **END** key. The Normal Communication screen appears in the display.

## Group Call

You can arrange with other vessels to use a group MMSID so that any vessel in a group can contact all other vessels in the same group with a single DSC call.

Your group MMSID is stored in the same manner as your ship MMSID. Only one group MMSID is stored at a time, but group MMSID's can be changed as often as desired, allowing participation in more than one group.

To send a DSC group call:

- Press the **CALL** key. The call menu appears in the display.
- Use the **SELECT** knob to select the **GROUP CALL** topic.



### DSC Group Call

- Press the **CALL** key. The **SET CHannel** menu appears in the display. The current group MMSID appears in the lower line of the display.

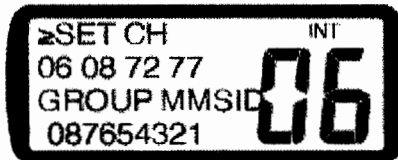

### Set Channel

- Use the **SELECT** knob or the microphone keys to select a working channel. Four channel numbers appear in the display as suggested channels authorized for this type of call. Other channels may be used if authorized in your area.
- Press the **CALL** key. The call is sent and **WAITING . . . .** appears in the lower line of the display.
- Your transceiver is automatically set to the previously set working channel. Listen for voice replies from vessels which have received your call. There is no DSC ACK reply to confirm that your call was received.
- Use the **PTT** button to continue voice communication. The Normal Communication screen appears in the display.

- If there is no response to your call, press the **END** key. The Normal Communication screen appears in the display.

## Receiving DSC Calls

Your *SX 35 DSC* can receive four types of DSC calls; Distress, All Ship's, Individual, and Group. Except for Distress, each call type is subdivided into one or more priorities.

All Ship's type receives the following priorities: Distress ACK, Distress Relay, Urgency, and Safety.

Individual type receives the following priorities: Safety and Routine.

Group type receives one priority: Routine.

When your *SX 35 DSC* receives a DSC call from another vessel or a coast station, an alert sounds and a Call Received screen appears in the display. The Call Received screen identifies the time of a call, the caller, the type and the priority of a call. Also, a number appears in the screen indicating the number of calls in the log. The call log holds thirty two entries.

## Individual Call Received

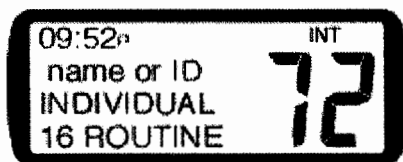

### Individual Routine

If the calling vessel or station is listed in your DSC calling directory, the vessel or station name, as it is listed, appears in the display. If the caller is not listed in your directory, the caller's MMSID appears in the display. Also, your transceiver is set to a working channel selected by the caller.

For Individual Routine calls the following screen alternates with the Call Received screen.

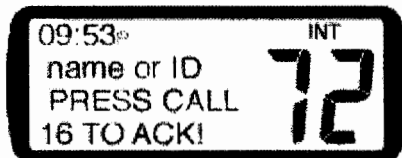

### Routine ACK Screen

- Press the **CALL** key to acknowledge the call. The sender should respond to your ACK with voice communication. If not, you may initiate voice communication.
- To silence the alert without sending ACK, press the **END** key. The call is interrupted and the Normal Communication screen appears in the display.
- To silence the alert and send ACK later, press the **ENT** key. The ACK screen continues to alternate with the Call Received screen in the display.

For Individual Safety calls, the following screen appears in the display.



**Individual Safety**

- Press the **END** key to silence the alert sound and listen for a voice announcement. There is no DSC ACK for Safety calls.
- Press the **PTT** button to answer the call with voice communication on the working channel selected by the caller.

### Last Call Received

Replies to incoming calls are made using the call log. The call log holds thirty two entries and the last call received is on top of the list. When the thirty third call is received, the oldest entry is lost. Making DSC calls from the call log is the like making calls from the DSC calling directory.

To instantly reply to the last call received or any log entry:

- Press the **CALL** key. The call menu appears in the display with the cursor indicating **LAST CALL**.



**DSC Call Menu**

- Press the **CALL** key again. The most recent call in the call log appears in the screen.

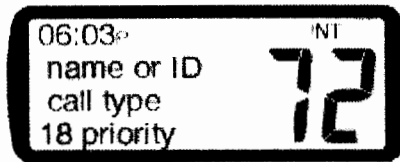

**Last Call**

- Observe the type and priority of the last call logged.
- Use the **SELECT** knob to select the entry to call.
- Press the **CALL** key. An Individual Routine call is transmitted regardless of the type and priority of the last call logged.
- Proceed in the same manner as with normal DSC calls.

**All Ships Call Received**

An All Ship's call is received from other vessels or coast stations within VHF range of the transmitter. All Ship's calls present Urgent or Safety information important to all vessels in the area.

When an All Ship's call is received, an alert sounds and one of the following screens appear in the display.

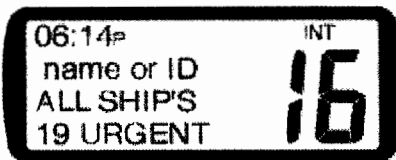

**All Ship's Urgent**



**All Ship's Safety**

If the calling vessel or station is listed in your DSC calling directory, the vessel or station name, as it is listed, appears in the display. If the caller is not listed in your directory, the caller's MMSID appears in the display. Also, your transceiver is set to Channel 16 by the caller.

- Press the **END** key to silence the alert sound and listen for a voice announcement. There is no DSC ACK for All Ship's calls.
- Press the **PTT** button if it is necessary to answer the call with voice communication. Use the channel selected by the caller.

## Group Call Received

A group call is received when anyone in your prearranged group makes a group call.

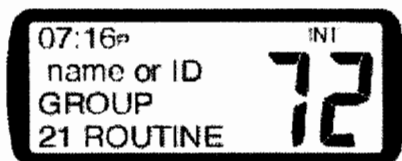

### Group Call Received

- Press the **END** key to silence the alert sound and listen for a voice announcement. There is no DSC ACK for Group calls.
- Press the **PTT** button to answer the call with voice communication on the working channel selected by the caller.



## REFERENCE

### Maintenance

The *SX 35 DSC* VHF transceiver is produced with proven processes and current solid state technology. With reasonable care, your *SX 35 DSC* will have a long useful life.

The following precautions will prevent damage to the transceiver.

- Never press the PTT button unless an antenna or proper dummy load is connected to the antenna jack.
- Do not operate the transceiver if the power source is not within the specified range of 11 to 16 Vdc.
- Replace the antenna and/or coaxial cable if damaged in any way or severely weathered.
- Avoid continuous direct sunlight on the LCD.
- Avoid overextending the microphone cable.
- Do not use solvents or harsh chemicals to clean the microphone, case-work or LCD display.

### Special Functions

#### Simulator Mode

Provides simulated GPS data for demonstration of realistic displays. Transmitter and DSC functions are totally disabled.

- Press and hold the **MENU** key while turning power On.

#### Clear Memory Channels

Clears the channel bank for the Memory Scan function.

- Press and hold the **MEM** key while turning power On.

#### New Microphone

Initializes the keypad when a new microphone is installed.

- Press and hold the  key on the microphone while turning power On.

#### Printer Operation

Initializes the Tx port for 4800 baud PC/printer interface.

- Press and hold the **16** key while turning power On.

## Troubleshooting

Troubleshooting Chart		
Symptom	Probable Cause	Corrective Action
Transceiver won't turn On.	No dc voltage, blown fuse, faulty wiring.	Rotate <b>VOL</b> knob CW, check buss voltage, replace fuse (6.3 Amp), check power cable and connections.
Buzzing sound from speaker with engine running.	Ignition or charging system noise.	Reroute dc power cable, install noise filter on alternator and dc power cable, use resistive spark plug wires.
No sound from speaker.	Squelch control set too high, volume control set too low.	Set <b>SQ</b> control full CCW, set <b>VOL</b> CW.
	Channel blocked by stuck mic button.	Select a different channel. Look for <b>TX</b> annunciator in display.
	Faulty external speaker or cable.	Unplug external speaker cable.
Reports of weak transmit signals even when using HI power settings.	Antenna.	Have a technician test transmitter output power and antenna VSWR.
	Coaxial cable faulty.	Inspect antenna cable carefully for nicks. Wet coax absorbs transmitter power.
Latitude and longitude coordinates are not displayed.	Lat/Long position display not turned On.	Use Menu/Dat/Gr/Y L-position, to turn On.
	GPS cable faulty or disconnected.	Check cable and connections.
	GPS not operating or position is invalid.	Make sure GPS is functioning and output format is NMEA 0183 with RMC sentence selected.

## Specifications

### SX DSC 35 Technical Specifications

#### GENERAL

Compliance:	Meets EU specification EN301-025 V1.1.2 (August 2000), Radio Regulations Appendix 18, and DSC Class D/SC-101.
Number of Channels:	All available INT'L (per Appendix 18). Externally FLASH programmable for various Country Requirements.
V <sub>dc</sub> Input:	13.6 Vdc with isolated chassis.
Size (W x H x D):	153mm x 61mm x 158mm (6.02" x 2.4" x 6.22"). Heat sink is included. Not bracket.
Weight:	1.088Kg (2.4 lbs) with MIC.
Waterproofness:	CFR-46
Antenna:	50 OHM impedance with SO239 Connector. Transmitter operates 5 minutes into OPEN or SHORT.
Temperature Range:	-20 Degrees C to +50 Degrees C
Construction:	UV Stable Case with Tactile-Feel colored silicon rubber key switches Backlighted rubber keypad. Die Cast Rear Heat sink.
LCD Display:	4 Lines with 11 characters each and BOLD channel number display with 3 discrete annunciators. Silver background with dark Black letters and Bright Orange display backlighting. LCD has dimmable ORANGE display/keypad backlighting. Contrast control provides best viewing angle. Viewing area is 63.3mm x 23mm (2.49" x .90").
Speaker:	Sealed Water Resistant Polypropylene.
Microphone:	Special styled MIC with 12 Alpha Numeric keys. MIC editing works simultaneously with Code Wheel and allows discrete channel entry.
Channel/Selection Changing:	2 bit Code Wheel.
Squelch/Volume Control:	Integrated, includes Power On/Off control.

- External Connections:** Jack for External Speaker & 8 pin COM connector.
- Watch Receiver:** Separate CH70 watch receiver included. Decoding performance is less than  $10^{-2}$  Bit error rate with 0dB $\mu$ V input signal level.
- CPU:** High-speed 8 bit RISC microprocessor with features/channels externally FLASH programmable.
- DSC Call Types:** See chart below:

Format Specifier	Category	First Telecommand Symbol number	Receive	Transmit
Distress - (112)		F3E/G3E Simplex - (100)	X	X
All Ship's - (116)	Distress - (112)	Distress ACK - (110)	X	
All Ship's - (116)	Distress - (112)	Distress RELAY - (112)	X	
All Ship's - (116)	Urgency - (110)	F3E/G3E Simplex - (100)	X	X
All Ship's - (116)	Safety - (108)	F3E/G3E Simplex - (100)	X	X
Individual - (120)	Urgency - (110)	F3E/G3E Simplex - (100)	X	
Individual - (120)	Safety - (108)	F3E/G3E Simplex - (100)	X	
Individual - (120)	Routine - (100)	F3E/G3E Simplex - (100)	X	X
Group - (114)	Routine - (100)	F3E/G3E Simplex - (100)	X	X
2 <sup>nd</sup> Telecommand Transmit & Receive (126) - No Information.				

- DSC Distress Key:** Red & Covered. Plastic Cover is hinged to prevent loss. Key is backlighted full time. Hold down 3 seconds - countdown timer is displayed.
- DSC Call Log:** 32 Entries. Instant call back any Log Entry with Individual Routine call.  
Caller's Name is displayed if MMSID matches to Directory Entry.
- DSC Directory:** 32 Entry list with scrolling and Auto Sorting. Entries can be edited to Line/Character position.
- MMSID:** Own Ship's & Group are stored in nonvolatile memory.
- Memory Scan Channels:** Unlimited with instant editing and can be cleared on Power-up. The Memory Channel list is presented in a Page Mode format with instant ADD/DELETE function.

Alarm Tones:	3 different tone sequences are provided.
Frequency Control Method:	Phased Locked Loop (PLL).
Frequency Stability:	+/-5 PPM for both the Transmitter/Receiver.
GPS/NMEA:	\$GPRMC sentence is decoded. NMEA Checksum can be turned Off/On.
GPS Display:	Data is selected from following: <ul style="list-style-type: none"> <li>• Date &amp; local time &amp; LL Position (3 digit for seconds).</li> <li>• SOG/COG&amp; LL Position (3 digit for seconds).</li> <li>• Time &amp; Manual LL Position (no seconds).</li> <li>• No Data.</li> </ul>
Data Output:	DSC call formats can be sent to PC & printer using 4800 baud and standard Terminal program.
Special Functions:	Three scanning Modes: <ul style="list-style-type: none"> <li>• All Scan</li> <li>• Memory Scan (nonvolatile)</li> <li>• Priority Scan</li> </ul> <p>Noisy channels can be temporarily deleted in All Scan Mode.</p> <p>Built-in GPS Simulator.</p> <p>Automatic Auto Calendar for clock.</p> <p>Manual Entry of LL &amp; Time for DSC Emergency Calling.</p> <p>Local Time Offset values can be entered in 30 minute intervals.</p> <p>Instant Access to "Last DSC Call".</p>

## **TRANSMITTER**

Power Output:	25 Watts or 1 Watt switchable.
Tx Current:	6 Amps @ 25W Tx. 1 Amp @ 1W Tx.
Modulation:	G3E for Voice, G3B for DSC Data.
Transmit Frequencies:	156.025Mhz - 157.425Mhz @ 25Khz spacing.
Spurious/Harmonic Emissions:	Less than 0.25 $\mu$ W.
Modulation Distortion:	Less than 4% @ 1Khz for +/-3Khz deviation.
Modulation Limiter:	+/-5Khz deviation with 100% modulation.
Frequency Response:	Matches +6dB/Octave slope within +1/-3dB from 300 to 2500Hz. 18dB/Octave beyond 3000Hz. Audio Low Pass Filter is included.
Hum & Noise:	Less than -40dB.

## **RECEIVER**

Receive Frequencies:	156.300Mhz - 162.000Mhz @ 25Khz spacing.
Sensitivity:	0.5 $\mu$ V or less for 20dB SINAD
Squelch Range:	0.25 $\mu$ V to 0.80 $\mu$ V @ full squelch
Audio Output Power:	3.0W minimum @ 4 Ohms with less than 10% distortion.
External speaker:	Internal speaker is Off when external speaker is On.
Receiver Current:	200mA in Standby ( 2 receivers)
Modulation Acceptance:	+/-7 kHz minimum.
Adjacent Channel Selectivity:	Greater than -70dB for +/-25Khz.
Image Rejection:	Greater than -70dB.
Intermodulation Spurious Response:	Greater than -70dB.
Noise Level:	Greater than -40dB unswitched.
Audio Frequency Response:	Matches -6dB/Octave slope within +1/-3dB from 300 to 2500Hz, 18dB/Octave over 3000Hz.

## **Channel Assignments**

The Channel Assignment tables on the following pages list the channel number, frequency and usage for Marine VHF communication.

Depending upon your selection, certain channels may be either simplex (single frequency) or duplex (two frequency) as indicated in the tables. On simplex channels, your transceiver transmits and receives on the same frequency. On duplex channels, your transceiver transmits on one frequency and receives on another frequency. You may communicate with shore stations on both simplex and duplex channels, but because of the frequency offset, you cannot communicate with other vessels on a duplex channel.

**Channel 16 is the International Distress, Safety and Calling channel. All vessels equipped with VHF transceivers are required to monitor channel 16.**

## VHF MARINE CHANNEL CHART

CH	U	C	I	S/D	TX	RX	CHANNEL USE
01A	●			S	156.050		Port operation, commercial (intership/ship-to-coast)
01		●		D	156.050	160.850	Public correspondence
01			●	D			Public correspondence, port operation, ship movement
02		●		D	156.100	160.700	Public correspondence
02			●	D			Public correspondence, port operation, ship movement
03	●			S	156.150		Public correspondence
03		●		D	156.150	160.750	Public correspondence
03			●	D			Public correspondence, port operation, ship movement
04A		●		S	156.200		Public coast : Coast Guard ; East Coast ; commercial fishing
04			●	D	156.200	160.800	Pacific correspondence, port operation, ship movement
05A	●			S	156.250		Port operation (intership/ship-to-coast)
05A		●		S			ship movement
05			●	D	156.250	160.850	Public correspondence, port operation, ship movement
06	●	●	●	S	156.300		Safety (Intership)
07A	●	●		S	156.350		Commercial (intership/ship-to-coast)
07			●	D	158.350	160.950	Public correspondence, port operation, ship movement
08	●	●	●	S	156.400		Commercial, intership
09	●	●		S	156.450		Commercial/non-commercial (USA : Alternate calling channel)
09			●	S			Port operation, intership, ship movement
10	●			S	156.500		Commercial (intership/ship-to-coast)
10		●		S			Commercial/non-commercial (intership/ship-to-coast), safety
10			●	S			Port operation, intership, ship movement
11	●			S	156.550		Port operation (intership/ship-to-coast) VST
11		●		S			Commercial/non-commercial (intership/ship-to-coast), ship movement
11			●	S			Port operation, ship movement
12	●			S	156.600		Port operation (intership/ship-to-coast) VTS
12		●		S			Commercial/non-commercial (intership/ship-to-coast), ship movement
12			●	S			Port operation, ship movement
13	●	●		S	156.650		Bridge-to-bridge, navigation (1W)
13			●	S			Port operation, intership, ship movement
14	●			S	156.700		Port operation (intership/ship-to-coast), VTS
14		●	●	S			Port operation (intership/ship-to-coast), ship movement
15	●			S	-	156.750	Receive only - environmental
15		●		S	156.750		Commercial/non-commercial (intership/ship-to-coast), ship movement (1W)
15			●	S			Port operation, intership, ship movement (1W)
16	●	●	●	S	156.800		Distress, Safety, and calling
17	●			S	156.850		Sate-controlled (1W)
17		●		S			Commercial/non-commercial (intership/ship-to-coast), ship movement (1W)
17			●	S			Intership, port operation, ship mvoement (1W)
18A	●	●		S	156.900		Commercial (intership/ship-to-coast)
18			●	D	156.900	161.500	Port operation, ship movement
19A	●			S	156.950		Commercial (intership/ship-to-coast)
19A		●		S			Coast Guard
19			●	D	156.950	161.550	Port operation, ship moevement



## VHF MARINE CHANNEL CHART

CH	U	C	I	S/D	TX RX		CHANNEL USE
20A	●			S	157.000		Intership,
20		●		D	157.000	161.800	Port operation (ship-to-coast) 1W
20			●	D			Port operation, ship movement
21A	●			S	157.050		U.S. Government
21A		●		S			Coast Guard
21			●	D	157.050	161.650	Port operation, ship movement
22A	●	●		S	157.100		Coast Guard
22			●	D	157.100	161.700	Port operation, ship movement
23A	●			S	157.150		U.S. Government
23		●	●	D	157.150	161.750	Public correspondence
24	●	●	●	D	157.200	161.800	Public correspondence (ship-to-coast)
25	●	●	●	D	157.250	161.850	Public correspondence (ship-to-coast)
26	●	●	●	D	157.300	161.900	Public correspondence (ship-to-coast)
27	●	●	●	D	157.350	161.950	Public correspondence (ship-to-coast)
28	●	●	●	D	157.400	162.000	Public correspondence (ship-to-coast)
60		●		D	156.025	160.625	Public correspondence (ship-to-coast)
60			●	D			Public correspondence, port operation, ship movement
61A	●	●		S	156.075		Pacific Coast: Coast Guard; East Coast: commercial fishing
61			●	D	156.075	160.675	Public correspondence, port operation, ship movement
62A		●		S	156.125		Pacific Coast: Coast Guard; East Coast: commercial fishing
62			●	D	156.125	160.725	Public correspondence, port operation, ship movement
63A	●	●		S	156.175		Port operation, commercial (Intership/ship-to-coast)
63			●	D	156.175	160.775	Public correspondence, port operation, ship movement
64	●			S	156.225		Public correspondence, port operation
64		●		D	156.225	160.825	Pacific Coast; public correspondence (ship-to-coast)
64			●	D			Public correspondence, port operation, ship movement
65A	●	●		S	156.275		Port operation, (Intership/ship-to-coast)
65			●	D	156.275	160.875	Public correspondence, port operation, ship movement
66A	●	●		S	156.325		Port operation, (Intership/ship-to-coast)
66			●	D	156.325	160.925	Public correspondence, port operation, ship movement
67	●			S	156.375		Commercial (Intership), VTS (1W)
67		●		S			Safety (Intership/ship-to-coast) East Coast: commercial fishing
67			●	S			Intership, port operation, ship movement
68	●	●		S	156.425		Non-commercial (Intership/ship-to-coast)
68			●	S			Port operation, ship movement
69	●			S	156.475		Non-commercial (Intership/ship-to-coast)
69		●		S			Non-/commercial (Intership/ship-to-coast), East Coast : commercial fishing
69			●	S			Intership, port operation, ship movement
70	●	●	●	S	156.525		Digital selective calling (DSC)
71	●			S	156.575		Non-commercial (Intership/ship-to-coast)
71		●		S			Pacific Coast : Non-comm (Intership/ship-to-coast), safety, ship movement
71			●	S			Port operation, ship movement
72	●			S	156.625		Non-commercial (Intership)
72		●	●	S			Commercial/non-commercial (Intership)

## VHF MARINE CHANNEL CHART

CH	U	C	I	S/D	TX	RX	CHANNEL USE
73	●			S			Port operation (intership/ship-to-coast)
73		●		S	156.675		Non-comm (intership/ship-to-coast), safety, East Coast : comm fishing.
73			●	S			Intership, port operation, ship movement
74	●			S			Port operation (intership/ship-to-coast)
74		●		S	156.725		Non-comm (intership/ship-to-coast), ship movement
74			●	S			Port operation, ship movement
75			●	S	156.775		Port operation, ship movement (1W)
76			●	S	156.825		Port operation, ship movement (1W)
77	●			S			Port operation (Intership)
77		●		S	156.875		Safety (Intership/ship-to-coast), ship movement
77			●	S			Intership
78A	●			S			Non-commercial (intership/ship-to-coast)
78A		●		S	156.925		Commercial (Intership/ship-to-coast)
78			●	D	156.925	161.525	Port operation, public correspondence, ship movement
79A	●	●		S	156.975		Commercial (Intership/ship-to-coast)
79			●	D	156.975	161.575	Port operation, ship movement
80A	●	●		S	157.025		Commercial (Intership/ship-to-coast)
80			●	D	157.025	161.625	Port operation, ship movement
81A	●			S			U.S. Government
81A		●		S	157.075		Coast Guard
81			●	D	157.075	161.675	Port operation, public correspondence, ship movement
82A	●			S			U.S. Government
82A		●		S	157.125		Coast Guard
82			●	D	157.125	161.725	Port operation, Public correspondence, ship movement
83A	●			S			U.S. Government
83A		●		S	157.175		Coast Guard
83			●	D	157.175	161.775	Public correspondence
84	●	●	●	D	157.225	161.825	Public correspondence (ship-to-coast)
85	●	●	●	D	157.275	161.875	Public correspondence (ship-to-coast)
86	●	●	●	D	157.325	161.925	Public correspondence (ship-to-coast)
87	●	●		D	157.375	161.975	Public correspondence (ship-to-coast)
87			●	S	157.375		Public correspondence (ship-to-coast)
88A	●			S			Commercial (Intership)
88		●		S	157.425		Public correspondence (ship-to-coast)
88			●	S			Public correspondence (ship-to-coast)
WX01	●	●	●		---	162.550	Weather (receive only)
WX02	●	●	●		---	162.400	Weather (receive only)
WX03	●	●	●		---	162.475	Weather (receive only)
WX04	●	●	●		---	163.275	Weather (receive only)
WX05	●	●	●		---	161.650	Weather (receive only)
WX06	●	●	●		---	161.775	Weather (receive only)
WX07	●	●	●		---	162.425	Weather (receive only)
WX08	●	●	●		---	162.450	Weather (receive only)
WX09	●	●	●		---	162.500	Weather (receive only)
WX10	●	●	●		---	162.525	Weather (receive only)

USA channels 13, 17, 87 Canadian channels 15, 17 and Int'l channels 15, 17, 75, 78 are automatically set to 1W low power when they are selected. 25W high power for channels 13, 87 USA channels is available by pressing the HI/LO key during TX mode.

**(C) 2004 Pony Electric Corp.**



# M-TECH

PONY ELECTRIC CORPORATION

No.202, 6-28, Akasaka 9-chome

Minato-ku, Tokyo 107-0052, Japan

Phone +81 (0)3 3405 5733

Fax +81 (0)3 3405 8677

\*M-TECH is the representative brand of Pony Electric Corporation

CE 0678 Ⓢ

(C) 2004 Pony Electric Corp.

EN02