

Classic  
**PORSCHE**  
No.51 25 JAN-14 MAR 2018 (UK)

# Classic **PORSCHE**

## **CARRERA CARUMBA!**

BEHIND THE WHEEL OF A RARE RHD 356 CARRERA 2



www.classicporschemag.com



US\$12.75 Can\$14.25 Aus\$11.95

chp £4.95

STIRLING MOSS AND PORSCHE: THE FULL STORY  
ELFORD'S MONTE MEMORIES ● ORIGINAL '69 911E





*Made in Germany | [www.fvd.net](http://www.fvd.net)  
Porsche® Tuning | Parts | Service*

since 1984

# Tuning | Parts | Service



Like us on Facebook  
[facebook.com/fvdbrombacher](https://facebook.com/fvdbrombacher)



Watch our YouTube™ Channel  
[youtube.com/fvdbrombacher](https://youtube.com/fvdbrombacher)



No matter if you need parts for your aircooled or watercooled, we have everything you need.  
Simply visit us at [www.fvd.net](http://www.fvd.net) and discover why more enthusiasts choose to put our passion into their Porsche®

**fvd** Germany      phone: +49-7665-98990      fax: +49-7665-989920      [www.fvd.net](http://www.fvd.net)  
**fvd** North America      phone: +1-954-571-2050      fax: +1-954-571-2060      [www.fvd.net](http://www.fvd.net)

# Classic PORSCHE

**Editor:** Keith Seume Tel: 01208 872924  
classicporsche@chpltd.com

**Contributors:** Robert Barrie, Antony Fraser,  
Kieron Fennelly, Sarah Hall,  
Delwyn Mallett, Robb Pritchard,  
Stephan Szantai, Johnny Tipler

**Studio Manager** Peter Simpson

**Group Advertisement Manager**  
James Stainer Tel: 01883 731152  
james.stainer@chpltd.com

**Production**  
Liz Smith Tel: 01883 731150  
ads@chpltd.com

**Accounts:** Bev Brown  
**Administration:** Sandra Househam  
**Subscriptions:** Debi Stuart  
debi.stuart@chpltd.com  
Tel: 01883 731150 Fax: 01883 740361

**Managing Director:** Clive Househam

**Printed in England**  
GD Web Offset Ltd; Tel: 01709 768000

**Worldwide stockists**  
To find your nearest stockist:

UK: seymour.co.uk/storefinder  
N. America: magfinder.magnetdata.net  
ROW: export.ops@seymour.co.uk  
For single copies and subscriptions:  
classicporschemag.com  
For digital copies and subscriptions:  
pocketmags.com

Classic Porsche is distributed worldwide by  
Seymour Distribution Ltd, Tel: 020 7429 4000,  
info@seymour.co.uk

chp pocketmags

Find us on  
Facebook

iTunes

twitter

#ClassicPorsche1

Classic Porsche® is published by  
CHPublications Ltd,  
1 The Alma Building,  
Brewerstreet Dairy Business Park,  
Brewer Street, Bletchingley  
Surrey RH1 4QP  
Tel: 01883 731150 E-mail: chp@chpltd.com

ISSN: 2042-107

While every effort is made to ensure the accuracy of this  
publication CHPublications Ltd. cannot accept  
liability for any statement or error contained herein.  
All rights reserved. Reproduction in whole or part,  
without written permission, is prohibited

© CHPublications Ltd, 2018



I never was one for learning Shakespeare at school, but certain lines have stuck in the memory during these past 50 years, or so. One is the quote from *The Merchant of Venice* which points out that ‘all that glisters is not gold’ (note ‘glisters’, not ‘glitters’ or ‘glistens’...), which is very apt in this world of ‘fast buck’ restorations, designed to dazzle unsuspecting customers with fancy paintjobs. *Caveat Emptor*, as they say – although I don’t somehow think Shakespeare is responsible for that one!

No, for me, the most pertinent Shakespearian quotation right

## “FAREWELL *EL CHUCHO*... SEE YOU DOWN THE ROAD...”

now is from *Romeo and Juliet*: ‘Good night, good night. Parting is such sweet sorrow that I’ll say good night until tonight becomes tomorrow...’. You see, I’ve just waved goodbye to *El Chucho*, my project of the last five years, and generator of much ink in this very magazine.

Having arrived at my ‘destination’ after a long and occasionally bumpy journey, I decided it was time to move on and let somebody else enjoy the ride. I’m not yet sure if the parting is sweet, but I definitely know it’s tinged with sorrow, but as one door closes, another will surely open. Farewell *El Chucho*, it’s been a fun time turning you from a rather neglected 912 into a modern hot-rod. See you down the road...

**Keith Seume**  
Editor, *Classic Porsche*  
classicporsche@chpltd.com

[www.classicporschemag.com](http://www.classicporschemag.com)



# CONTENTS

## FEATURES

- FROM RS TO R GRUPPE** 08  
How one man turned an RS replica with a poorly engine into a thing of beauty
- FRIENDS REUNITED** 30  
We reunite a rare RHD 356 Carrera 2 with two of its original owners
- FRUIT SALAD DAYS** 38  
Behind the wheel of a perfect example of an early Porsche 911E
- MOSS MAGIC** 46  
Arguably the most famous British racing driver of all, Stirling Moss
- DANCING ON ICE** 56  
Vic Elford and co-driver David Stone reminisce about the 1968 Monte Carlo
- R GRUPPE EXPERIENCE** 64  
We catch up with the famous club at LA's new Porsche Experience Center
- MANFRED'S THE MAN** 70  
Manfred Hering has a collection of over 400 Porsches, plus a restoration shop
- PORSCHE AT CARAMULO** 80  
The Caramulo hillclimb is often referred to as the Goodwood of Portugal
- BRAKING POINT** 86  
Looking back over half a century of Porsche brake technology



## SUBSCRIBE TO *Classic* PORSCHE

*Don't miss a single issue of the only magazine that covers every aspect of the Porsche scene.  
Why not subscribe today?  
You'll save money, too!*

Just turn to page... **98**







# REGULARS

**NEWS & PRODUCTS** 16

News & reviews from the Porsche world

**DELWYN MALLET** 22

Mallett's mental meanderings

**ROBERT BARRIE** 24

On values – and more

**LETTERS** 26

We hear from you

**CLASSIFIEDS** 95

Find the classic Porsche of your dreams







GEARED TO WINNING



- High quality Klingelberg crown wheel and pinions
- We can produce special ratios
- Crown wheel and pinions for Porsche 356 (7:31), 901 (7:31) and 915 (8:35) available from stock
- More than 65 years experience in the production of high quality gearing for automotive, aerospace, military and industrial applications

**Tandler Precision Limited**  
 29 Ross Road Business Centre  
 Northampton NN5 5AX  
 Tel: 01604 588 056 Fax: 01604 588 064  
 Email: sales@tandler.co.uk  
[www.tandler.co.uk](http://www.tandler.co.uk)

## THE CLASSIC SPECIALIST

With nearly 30 years experience, PARR has the knowledge to repair and your Porsche to the finest standard using our highly trained technicians.

For all your cherished Porsche requirements – from minor body rep to a full concours restoration – talk to Parr.

CLASSICS // RESTORATION // SALES // TUNING // SERVICING // REPAIR // KNOWLEDGE // FACILITIES  
 PARR Specialists In Porsche 5 The Faraday Centre, Faraday Road, Crawley, West Sussex RH10 9PX  
 +44 (0) 1293 537 911 // PARR-UK.COM





## The grip of winter. Porsche winter wheels and tyres.

Below 7°C the rubber compound in summer tyres hardens causing a drop in performance and increased braking distances\*. Porsche Approved N-rated winter tyres are specifically designed to provide greater safety in cold, wet and snowy conditions. Your summer wheels and tyres can also be securely stored for you by your local Porsche Centre\*\*. For more details visit your local Porsche Centre.

\*Summer tyres versus winter tyres. Braking with ABS on wet road surface, 50 to 0 mph at +3°C. \*\*Participating Centres only.



PORSCHE

# FROM RS TO R GRUPPE

Some Porsche enthusiasts will likely relate to Fabien Bécasse's journey through our scene. Think air-cooled VWs, 356s and 912s, followed by a handful of 911s... His latest project is a Gulf Orange '73 'T' which – through an unexpected chain of events – turned from an RS clone into an R Gruppe-approved street/track contender, running a potent 3121cc engine!

Words & photos: Stephan Szantai

Additional photos: Christelle & Fabien Bécasse





**W**hile some Porsche buffs see it as a dark secret, others like Fabien Bécasse make no apology about their deep interest in VWs. Many young drivers obviously cannot afford a 911 today and the same was true 30 years ago, when the French-born citizen (and resident at the time) went on a hunt for his first car, without having his driver's licence yet. So, like some of us, he did the next best thing: buy a Volkswagen Beetle.

Fabien loved it and soon became heavily involved with the Vee Dub scene, eventually partnering during the early '90s in a shop called T.Fabs Design in his home-country –

it produced numerous innovative and colourful VW project cars. But his interest in Porsche remained strong, hence the idea of building a 'hybrid', in the shape of a Volkswagen Crew Cab hiding a 3.0-litre SC flat-six and 915 gearbox. Incidentally, the vehicle still exists in France and Fabien plans to revive it one day.

Akin to many 'car dudes', he had an unequivocal attraction to California and its vibrant automobile scene, longing to move there if the occasion arose. It finally happened in 2007, leading to the launch of an import/export company, Vintage Autohaus USA. His former partner at T.Fabs handled the business on the other side of the world, through a second entity, Vintage Autohaus

*Below: Originally built as a Carrera RS clone, this 911T adopted a new personality following some subtle changes made by its owner*





France. And the duo soon got busy buying and shipping vehicles – over 750 in 10 years.

This gave Fabien the opportunity to see a bunch of cool cars, potentially snagging some great finds for himself along the way, as you might expect. After all, how can you pass a nice Ivory '67 Porsche 912 for \$6000 dollars, for instance? The latter became his daily driver, although he remained highly interested in air-cooled VWs, building a 180-horse 1967 'Cal Look' Bug, among others.

Yet, Fabien blames a famous meet for his deeper involvement with Porsches: 'In October 2011, I went to my first large Porsche event, Rennsport Reunion IV at Laguna Seca. Returning home, I sold my '55 Pre-A 356 project car to finance the purchase of my first 911 – an Italian-delivery Tangerine 1973 911T bought in Florida from Brumos. Then in 2014, I became a member of the R Gruppe with this car,

slightly lowered and running 7Jx15 American Racing Torq Thrust wheels. My wife Christelle and I drove it to our first R Gruppe Treffen that same year – I still have that car.'

Enter the subject of this article, a second orange 911, though dressed in a slightly different hue... In May 2013, Fabien found this other '73 911T via the Pelican Parts forum: it was a freshly-built Gulf Orange RS clone equipped with a 2.7-litre 'S-spec' engine. He had no plans to buy it at the time, but he was commissioned by his very good British friend Rick Pearson to do a pre-purchase inspection... (Fabien and Vintage Autohaus had been helping Rick with logistics, when he flew to the USA to race his Streamliner at Bonneville Salt Lake.)

Rick told him in essence: 'I'm interested in buying the 911, but I need someone to drive it occasionally when I'm not in California.' It took Fabien the first half of one second to accept

*Above: Fabien chose to retain the RS-style rear fender flares, but replaced the RS front bumper with one from a 911T*

*Below: Original paint 912s and 911S help keep the R Gruppe hot-rod company in Fabien's capacious unit*





*Below: Blacked-out trim, the R Gruppe side stripes, matt-anodised wheels with no centre caps and open lug nuts: all help to give the car a purposeful look...*

the offer. 'I found it to be a well-built Porsche, when driving it to several Cars & Coffee meets in Irvine,' he adds.

This is when our story took an interesting turn. Fabien's friend Ron Fleming of FAT Performance had a 3.0-litre long-block motor on his shelves. He wanted to install it in either his own 911 or his VW Crew Cab project... Fabien continues: 'I convinced him to sell it to me, so that he could build a hot rod engine for a '72 911T base-car I bought, which I planned to use for an ST project. Ron assembled a strong engine at FAT with a bunch of great components, increasing the displacement to 3121cc, while Shaun at Rancho Transaxles rebuilt a '73 915 gearbox, featuring close-ratio gears and a GT limited-slip differential. But I had not even started working on the '72 project yet – I knew the 3.1-litre engine and transmission were going to sit for a while before being used!'

Fast forward to 2015, when Fabien and Christelle went

to both the Rennsport Reunion and R Gruppe Treffen at Laguna Seca with a few friends, including Rick. On the way back to Southern California, the motor of his Gulf Orange 911 lost all its compression; thankfully, they were able to limp the vehicle home. It became clear that the flat-six

needed to be rebuilt...

After that the coupé sat somewhat forlorn at Vintage Autohaus USA for over a year before Rick decided to sell it with its broken engine to Fabien.

The latter was keen to accept the offer, knowing that he already had a FAT-built 3.1-litre, plus 915 gearbox...originally destined for his '72 project car. Ron helped with the swap and tune-up; yet, Fabien wasn't pleased with the overall look of the

vehicle. Even his wife told him 'this car isn't you!' He knew what he needed to do: remove the most obvious RS features, leading to a hunt for an ST rear bumper, followed

**“HE KNEW WHAT HE HAD TO DO: REMOVE THE MOST OBVIOUS RS FEATURES...”**







by an original front 'T' bumper and decklid, which he located at the 2017 All Porsche Swap Meet (see report in CP #44). However, the rear RS metal flares stayed.

When we recently talked to Fabien, he divulged that he had performed a bunch of other alterations since, a fact confirmed when we received the few pictures he emailed to us. So, the time had come to visit our friend near San Diego and see if his ride lived up to *Classic Porsche's* expectations. Spoiler alert: it did.

Parked inside Vintage Autohaus USA's freshly-built 'barn', the car looked fantastic, though other vehicles surrounding it made for excellent eye candy as well. We were

obviously drawn to his early Porsches, especially the Italian-delivery Tangerine 911T mentioned earlier in our piece, in addition to a pair of beautiful 912s: a '66 in Light Ivory and a sunroof '67 (shod with American Racings) in Bahama Yellow which, incidentally, is still wearing its original paint.

Walking around the 'GULF911', one can appreciate the still perfect paintjob, recently adorned with R Gruppe side logos – note lack of 911T rocker mouldings underneath. Fabien wasn't overly excited about the low-profile tyres fitted on the

7Jx15 and 8Jx15 Fuchs, hence he replaced them with sticky 185/70R15 and 215/60R15 Avon CR6ZZ rubber. Most of the

*Above: RS Lightweight seats and carpet follow the sport-purpose theme of the vehicle*

## “WASN'T OVERLY EXCITED ABOUT THE LOW-PROFILE TYRES”

*Below left: Fabien Bécasse wears a permanent smile – unsurprising given where he lives and the cars he owns*

*Below right: Fed by a pair of 46mm PMO carbs, the FAT-built engine delivers no less than 321bhp*

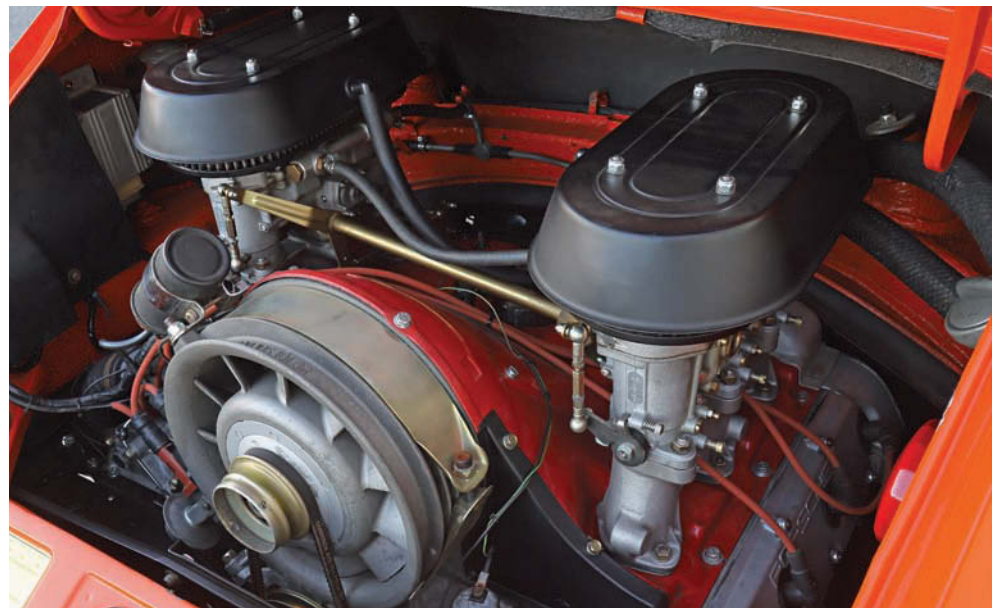



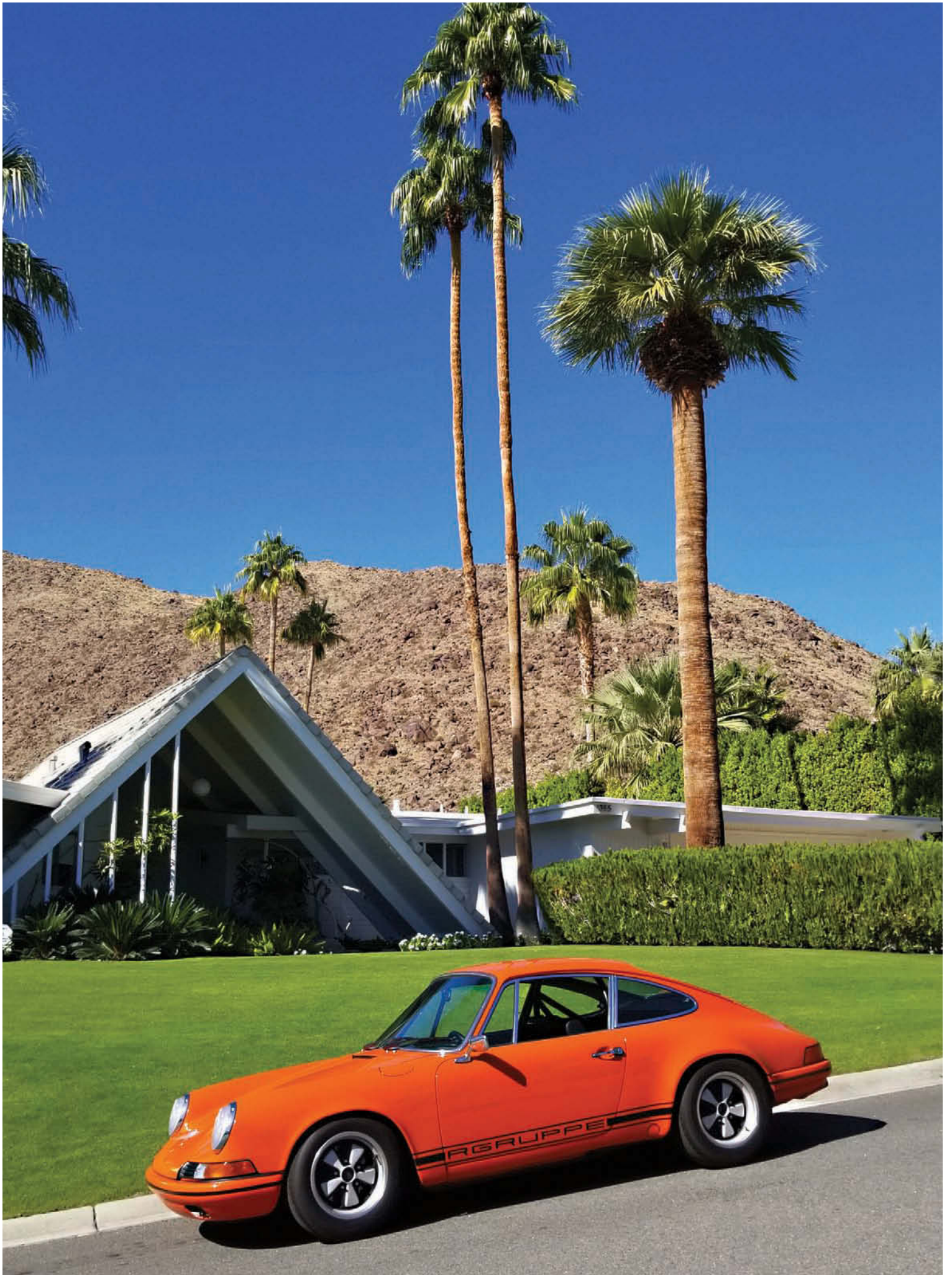





chassis components installed during the RS conversion remain in place, including the four Bilstein Sport shocks, SC brakes at all corners, together with front and rear sway bars. Incidentally, the aluminium front/rear suspension arms came from a 1985 Carrera.

In the spirit of the R Gruppe, Fabien also redid the interior with RS Lightweight seats and carpet, whilst the rear seat was removed, thus visually enhancing the roll bar – a copy of a factory period-correct unit. The shifter and dash remain stock, save for the 10,000rpm tach, located behind a Momo Prototipo steering wheel.

Following the sudden demise of the 2.7-litre lump, the 911 was given a new lease of life courtesy of that 3.1-litre with a compression ratio of 8.5-to-1, assembled by Ron Fleming. His recipe includes an SC case, S-spec cams and a pair of 46PMO carbs, along with a few Carrera goodies (tensioners and

front-mounted oil cooler). Fabien wanted an exhaust with a great sound; so, he contacted Martin Scart in France (see [www.scart.com](http://www.scart.com)) who custom-made a good-looking ST-style system with short headers. 'Angry' yet sufficiently quiet, the exhaust was the perfect last piece of the puzzle.

Starting with what started out as 'just another' RS clone, Fabien managed to make the GULF911 his, proudly representing the R Gruppe in the process. He finished the project one day before the memorable Luftgekühlt 4 event (see CP #45) and hit the road a week later for a 1200-mile trip to the 2017 R Gruppe Treffen in Napa.

The outing included a track session at Thunderhill in Willows, California, where the 911T surprised many competitors... Indeed, with 321 dyno-tuned horsepower, the car proves as much fun on racetracks as on the winding roads of San Diego County! **CP**

*Above: Scart built the special exhaust system to Fabien's specification, the end result being a system which delivers on both performance and sound levels*

## “THE EXHAUST WAS THE PERFECT LAST PIECE OF THE JIGSAW PUZZLE”

*Below left: Long wheel studs and no centre caps: two little details that help give the Tangerine 911 the right 'look'...*

*Below: Tucked away with Fabien's 1967 DKP Cal Look VW and his other orange 911. Storage also houses cars Fabien has on consignment*





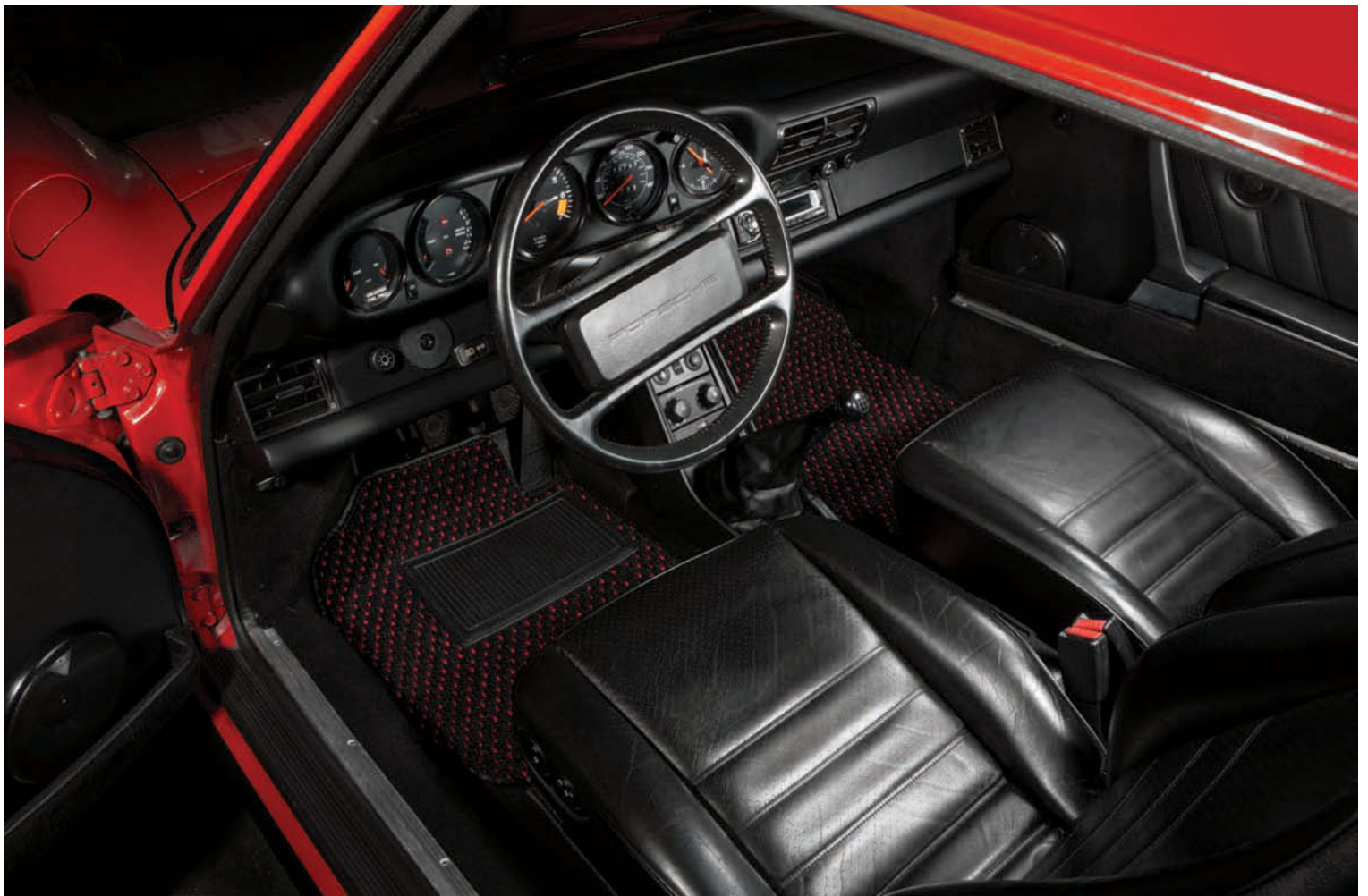

First introduced for the newly developed 356, Coco Mats were the original factory accessory floor mat. New and improved, Coco Mats are the only period correct auto mat that will complement any classic Porsche®. Available for 356's to 991's.

**COCO MATS**

**The Original Auto Mat.**

[www.cocomats.com](http://www.cocomats.com) 001.803.548.4809

# NEWS & PRODUCTS

What's happening in the classic Porsche world...

Got something new? Send details to [classicporsche@chpltd.com](mailto:classicporsche@chpltd.com)

## WEB REPLACEMENT

Beltwerks has quietly been supplying and restoring classic road and race seatbelts using 100 per cent correct reproduction seat belt webbing as used on the LWB cars of the 1969–73 era. They are pleased to announce the retail sale of correct Euro- and Rest of the World-specification seat belt material, which

has been obsolete since the early 1970s.

Each of the webbing materials pictured are fully certified and exceed the industry safety standards worldwide – technical data is available upon request. The material is sold in seven-metre coils, which will refurbish one set of front seatbelt reels. Both webbings are correct for post-'71 cars, and is also an excellent choice to upgrade

from the earlier '69–'71 fixed belts. Both materials are priced at £125.00 per coil, including shipping.

Beltwerks tells us, 'We are also able to supply fully restored seat belt sets to factory or custom specifications subject to hardware stock. Please enquire.'

Beltwerks also have a great reputation for their Repa and Britax three-point race harnesses which are built to exacting standards, and are proud to have supplied harnesses for some of the finest factory Porsche race cars including the recently-restored Toad Hall ST and 911R 016, amongst others.

Please contact David for webbing sales, or enquiries regarding standard or custom seat belt applications by dropping an e-mail to [beltwerks@yahoo.com](mailto:beltwerks@yahoo.com)  
*STOP PRESS: Beltwerks will have belts, harnesses and these new webbing samples to view on their stand at the LA lit show on Saturday 3rd March.*

## MORE FROM KK

How about a pair of excellent quality headrests correct for all Porsche 356, 911 and 912 up to 1967? They're a KK exclusive and made in house, and come ready to upholster to match your car's interior. The kit includes two headrests, four brackets and eight screws. They retail at £299.99 per pair, plus free p+p to all UK mainland customers.



Also on offer are these rear bumper deco strips, which will fit all 911 and 912s 1965–68 (two required per vehicle). They're also available for the '69–'73 models. Both come complete with base gasket. They're sold individually and priced at £102.00 each for the '65–'68 model and £58.36 for the '69–'73 model. [www.karmannkonnektion.com](http://www.karmannkonnektion.com)



## 2.4S AT HISTORICS...



It's a New Year, so maybe it's time to treat yourself to a new toy? If so, how about this little gem? It's coming up for auction at Historics in March.

At the time of purchase by the vendor in 2003, this right-hand drive Porsche 2.4 litre 911S, originally supplied on 8th November 1971 (chassis #9112300040 and engine #6320079), appeared to be in reasonable condition, having already had professional work carried out. Nevertheless, the fastidious vendor intended to keep the car for a number of years and set about a complete restoration.

The engine had previously been rebuilt and, after close inspection, it was decided the rebuild had been accomplished to a good standard and was left untouched.

The vendor commissioned Sportwagen of Essex to restore the bodywork although he had to wait a significant amount of time due to a full order book. Fabrication work was carried out to exemplary standards, with a number of panels replaced and a superb paint finish applied. An extensive collection of photographs confirms the quality and comprehensive nature of the work completed by Sportwagen.

Mechanicals were taken care of by Porsche specialist JAZ of St. Albans, with considerable care and attention paid to using factory parts wherever possible, the end result being a fully rebuilt 911 2.4 S of the highest quality.

A significant history folder confirms the full extent of the restoration with invoices totalling £35,000 in labour costs alone, plus a huge list of parts.

This car is surely one of the best examples available today. With a restoration project taking some three years to complete and costing circa £150,000, the sale of this museum-quality Porsche is an opportunity to beat the queue and enjoy the benefits of this wonderful model immediately. Estimate is £165,000–£190,000. This 1971 Porsche 911S will be auctioned by Historics at its major Spring sale at Ascot Racecourse on Saturday 3rd March, preceded by two viewing days on the Thursday and Friday prior. Full details of this and other classic Porsches, and all 140 varied consignments, plus bidding information, is available at [www.historics.co.uk](http://www.historics.co.uk)





# HIDDEN TREASURES



One of the UK's foremost independent Porsche specialists, BS Motorsport of Westcott in Buckinghamshire, has acquired a substantial quantity of rare and highly desirable used spares from a former collector and enthusiast based in the south of France. And the vast majority are now up for sale to help give life to other projects and restorations.

The hoard – so extensive that it took more than two dozen large wooden crates and an articulated lorry to bring them the nearly 1000 miles to southern England – spans the air-cooled 911 period from around the late 1960s through to the mid-1990s.

Many of the crates have yet to be fully unpacked, says proprietor Neil Bainbridge, but among the visible treasures are body panels, interior trim and seats, suspension and steering systems, brake calipers and cylinders, engine barrels and pistons, oil-coolers, crankcases, MFI pumps, oil and fuel tanks, instruments, exhausts, steering wheels, door cards, and not least a number of crack-free dashboard tops – although unsurprisingly all of those appear to be for left-hand-drive vehicles.

There are numerous sets of Fuchs and cookie-

cutter wheels, plus some later 964 and 993 rims and a number of French-made racing curiosities, and around 25–30 more or less complete engines. Those include several 911S units – identifiable by their red-coloured cooling shrouds – and at least one for a 2.7 RS. Some dozen or so gearboxes were among the collection, too. There is also a 32-valve engine for a 928, together with its own almost equally massive automatic transmission.

'We have already made a start on identifying and cataloguing the engines and gearboxes,' says Bainbridge, 'and the relevant information, including variant and serial numbers, is up on our website. I'll be using a few for in-house projects, but the remainder are available either as they stand or, for extra cost, rebuilt to the customer's requirements.' The same goes for the



transmissions, adds Neil, and unsurprisingly also the MFI pumps in which he now has a particularly keen interest – and ability, let it be said.

Condition of the items, as you would expect of

a collection amassed over many years, and from countless different vehicles, is best described as 'variable', but there can be no doubt that all have a considerable value. A dirty or even damaged speedometer, suitable for professional refurbishment, has to be a vastly better proposition than no speedometer at all. And an

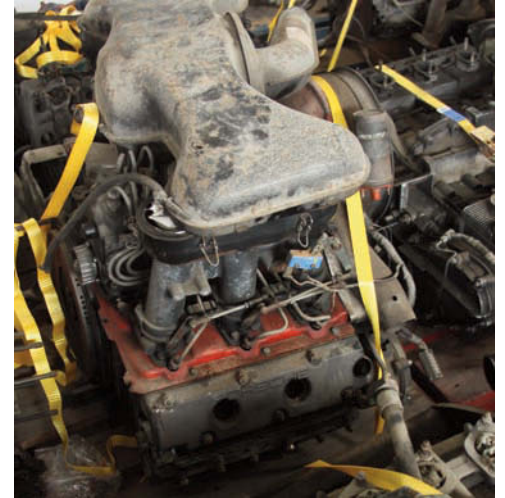

original seat, however down-at-heel it may be today, is in the right hands one of the finishing touches of any top-quality restoration.

Worldwide shipping is available for those not within reach of Westcott. For more details, and high-resolution photos of much of the collection, go to the BS Motorsport website at [www.bsmotorsport.co.uk](http://www.bsmotorsport.co.uk). There you will also find details of the company's other activities, including remanufactured engine and transmission parts, dyno testing, car storage, pre-purchase inspections, and even a forensic-level VIN-checking service.

# TURBO HISTORY

Parabolica has announced its second specialist Porsche book. *Turbo 3.0* dives deep into the development, production and mystique behind the three years of Porsche's 3.0-litre Turbo production, from 1975 to 1977. The book is painstakingly researched using the Porsche factory archives, private collections, period documentation and intensive study. Parabolica reckons *Turbo 3.0* will be the definitive book about the immortal 3.0-litre Turbo and essential reading for owners, restorers, historians, enthusiasts or anyone who has ever owned, driven or simply lusted after Porsche's first turbocharged supercar. At \$340, or around £250, plus shipping and taxes, it is a must for every enthusiast. It is 536 pages of stupendous production quality and limited to 2500 copies. [www.parabolicapress.com](http://www.parabolicapress.com).



# WIN A COPY OF 911 LOVERS

In the last issue of *Classic Porsche*, we brought you a preview chapter from the great new book covering the story behind the R and RS models of the 911 family. Called *911 LoveRS*, it is one of our books of the season and a must for every enthusiast's bookshelf. If Santa Claus didn't leave one in your Christmas stocking, don't despair, for we have a fresh off the presses copy for one lucky reader to win, courtesy of Delius-Klasing, the German publishers behind this wonderful tome.

To enter the competition, all you need to do is answer the following questions:

1. In what year did the 1973 Porsche Carrera RS first appear?
2. How many 911Rs were produced, including the four prototypes?
3. What does MFI stand for?

Send your answers, along with your name and address, to [classicporsche@chpltd.com](mailto:classicporsche@chpltd.com) by 15th March 2018. The winner will be drawn at random and notified by e-mail. Good luck!

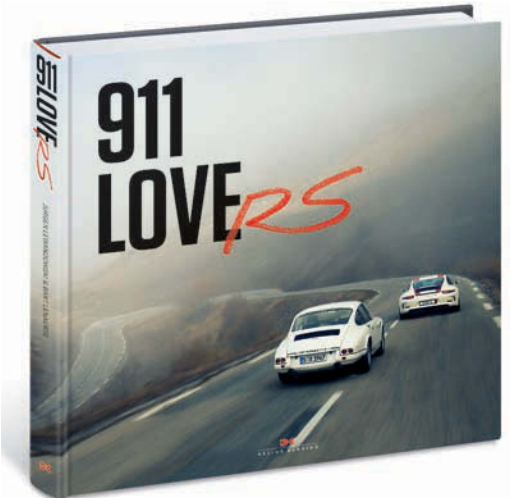



# NEWS & PRODUCTS

## EXHAUSTED!



If winter does nothing to dampen your enthusiasm to drive an air-cooled 911, then you'll be familiar with the heater controls, and how to keep comfortable behind the wheel.

At the business end of things, heat is directed from the exhaust, and piped towards the cabin, courtesy of heat exchangers.

However, due to the heating and cooling of the air contained within them, condensation forms and rust eats them from the inside out.

Heritage Parts Centre are on hand, though, with a range of corrosion resisting stainless-steel items that will keep the warmth flowing and make the need to replace your heat exchangers again a thing of the past. Available for all Porsche 911s from '65-'89, prices start at £389.95 each.

But if heat is overrated in your world, how about boosting the power and improving the sound output?

You could do a lot worse than sending all your car's spent gases packing through this gorgeous Vintage Speed merged exhaust system.

Engineered in #304 stainless-steel with 38mm-diameter headers, this system is optimised for maximum torque and horsepower, and is perfect for cars producing up to 200bhp. Not only does it look beautiful, it sounds sensational, too. We ran one on our project car and loved the sound and fit.

Available with a choice of tailpipe configurations, the silencer has two threaded bungs for lambda sensors to assist when tuning carburettors or EFI.

You can find these in stock now at Heritage Parts Centre; they're priced just shy of £2488 and come delivered free in the UK. Part numbers are PC1110084 and PC1110085

If the above items appeal to you (and we're sure they will), jump on the phone and dial 01273 444044, or find them online at:

[www.heritagepartscentre.com](http://www.heritagepartscentre.com)



### MISSED A COPY?

Every issue of *Classic Porsche* is available digitally ([pocketmags.com](http://pocketmags.com)), but if you prefer your reading the old-fashioned way then we only have the following back copies available: 4, 10, 13, 14 and 16-50. The price per copy, including p&p, is £5.80 (UK), £7.00 (Europe) and £8.50 (Rest of World). Call us on +44 (0)1883 731150, or e-mail: [chp@chpltd.com](mailto:chp@chpltd.com)

## COMING IN THE NEXT ISSUE...

*Classic*  
**PORSCHE** **TOUGH LOVE – MUSCLEBOUND 914/6 GT**

Contents subject to change

**ISSUE #52 – ON SALE MARCH 15TH 2018**

Overseas (approximately): Europe March 22nd; N. America April 19th; Australia/NZ May 17th. For your nearest stockist worldwide see page 3

### BECOME A CLASSIC PORSCHE AGENT?

Do you run a business that caters for the classic Porsche market? If so, would you like to become a stockist of *Classic Porsche* magazine? We are always on the lookout throughout the world for people to become specialist stockists – if you think this could be you, please call Bev Brown at CHPublications on +44 (0)1883 731150, or drop her an e-mail at [bev.brown@chpltd.com](mailto:bev.brown@chpltd.com) now!



THE ASCOT CLASSIC AUCTION, ASCOT RACECOURSE

SATURDAY

03

MARCH

# THE COLOUR OF ENVY



## FOR SALE BY AUCTION IMPECCABLE 1971 PORSCHE 911 2.4S

**Presented in the finest condition following £120,000 restoration. Estimate: £165,000-£190,000**

We are proud to provide this rare opportunity to purchase one of the finest, righthand drive examples of a 1971 Porsche 911 2.4S at our major spring auction on Saturday, 3rd March at Ascot Racecourse. Impeccably-presented and maintained regardless of cost, this exceptional classic Porsche has been the benefactor of a 100% authentic and

professional restoration totalling over £120,000, including £35,000 of labour costs. For full details of this and other fine Porsches amongst the 140 consignments and fascinating automobilia, plus information on bidder registration, please visit [www.historics.co.uk](http://www.historics.co.uk), where consignments are continuously updated.

#### VIEWING DAYS

Thursday March 1st, 10am - 8pm

Friday March 2nd, 10am - 5pm

#### SALE TIME

Saturday March 3rd, 10.30am

FINE CLASSIC CAR & MOTORCYCLE AUCTIONEERS  
Tel: 00 44 (0) 1753 639170 | E-mail: [auctions@historics.co.uk](mailto:auctions@historics.co.uk) | [www.historics.co.uk](http://www.historics.co.uk)



**HISTORICS**  
AT BROOKLANDS





Vintage Sports Seats

# PORSCHE SEATS SPECIALIST



Our model Sport S-RSL-RR-ST-R-A-300-LOLLIPOP, are identical to the original. We can customize any color and material ensuring the highest quality. We also produce tilting brackets, fixing brackets and set sliders for a quick and easy installation. We ship worldwide.

[www.deser.it](http://www.deser.it)

Tel/Fax +39.011.2733147 | Strada San Mauro, 206 - 10156 Torino Italy



Restoration -  
Paint - Modifications



Hand crafted restorations to the highest standards  
Multi award winning body and paint

Based in the West Midlands

01384 636459 - 07852 744911

[www.dcclassics.co.uk](http://www.dcclassics.co.uk)



## ROGER BRAY RESTORATION

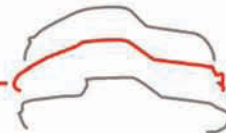

CLASSIC PORSCHE  
PARTS AND SERVICE

**911 / 912 / 356 emblems  
and decals available as well  
as many more parts for your  
356 911 912 914.**

We stock the largest selection of new parts for 356, 911, 912, 914, including Body and Interior, Mechanical, Electrical and Engine. We also have a large selection of used parts.

In fact we stock everything you need to keep your classic Porsche on the road!!



## CLASSIC PORSCHE RESTORATION, SERVICING AND PARTS

Roger Bray Restoration, Milestone Business Park, London Road, Whimble, Exeter. Devon. EX5 2QB

Tel: +44 (0)1404 822005 - Email: [enquiries@rogerbrayrestoration.com](mailto:enquiries@rogerbrayrestoration.com)

[www.rogerbrayrestoration.com](http://www.rogerbrayrestoration.com)



# EVERY PART FOR every PORSCHE

Call our Sales Team on  
**+44 (0) 20 8500 8811**

Visit our Online Catalogue at  
[www.design911.com](http://www.design911.com)

E-mail us on  
[sales@design911.com](mailto:sales@design911.com)

## DESIGN 911

Centre for Porsche

- LIGHTING & RUBBER SEALS
- SERVICE PARTS
- AIR COOLED ENGINE PARTS
- WHEEL & TYRES
- REPAIR & RESTORATION PARTS
- GEARBOX & DRIVE TRAIN PARTS
- SUSPENSION & EXHAUST
- PARTS DEPARTMENT
- WORLDWIDE SHIPPING



### WAYS TO BUY



IN PERSON



PHONE



MOBILE SHOP



WWW



E-MAIL



**5% OFF**

use online code  
**CLASSICP9**  
at checkout

**DESIGN911**  
CLASSIC CAR CENTRE

Telephone:  
**+44 (0) 20 8500 8811**



Porsche 911T 1969 2.0L Coupe  
Manual Gearbox, LHD, Polo Red  
code 6802 with Black interior.



Porsche 911SC 1983 Cabrio 3.0  
Manual Gearbox, LHD, Grand Prix  
White with Black interior.



Porsche 911T 1973 Coupe 2.4  
Manual Gearbox, LHD, Sepia Brown  
with a Dark Brown interior.



Porsche 964 M491 WTL 1994  
Carrera 4 3.6L, Manual Gearbox,  
LHD, Midnight Blue.



Porsche 912 Coupe 1967  
Manual Gearbox, LHD, Bahama  
Yellow with Black interior.

SEE OUR WEBSITE FOR A FULL LIST: [WWW.DESIGN911.COM/CARS](http://WWW.DESIGN911.COM/CARS)



# DELWYN MALLETT

THERE'S NOTHING WORSE THAN A MELANCHOLY MALLETT, BUT THIS TIME HE REACHES NEW LOWS AS HE CONTEMPLATES A FUTURE WITHOUT DRIVERS – OR NOISY EXHAUSTS...

Many would describe Delwyn Mallett as a serial car collector – one with eclectic tastes at that. His Porsche treasures include a pair of 356 Speedsters, a Le Mans-inspired Pre-A coupé and a 1973 Carrera RS. Some of them even work...

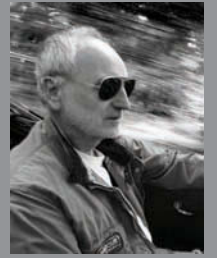

**B**eware! The Pods are coming. No, not a Hollywood sc-fi blockbuster but the future of motoring, coming to a road near you sooner than you think. A car chum and his younger relative dropped by recently for a natter and a poke around the garage. During our ramble over the subject of older cars, of which his knowledge was fairly limited, the younger of the two, probably in his mid-twenties, asked if a '73 Carrera RS really is as good as people say?

His dad has a 911, he wasn't sure what model, so he had some Porsche points of reference, but the fact that the RS is approaching twice the age of the enquirer and belonged to quite a different automotive era made it a bit tricky to form an adequate answer. Both 'yes' and 'no' would be appropriate but I mumbled something about 'alive and rewarding' and also threw 'visceral' into the adjectival mix.

Visceral is particularly appropriate as the RS, perhaps just that bit more than its siblings, appealed directly to the gut emotions and instincts in a way that all great driving machines do.

Reflecting on my inability to communicate what exactly it is that makes a 45-year-old RS feel so good to drive I began to muse on what questions a young man might ask his grandad in 45-years' time, and a wave of panic swept over me. I won't be here in 2063 but it's becoming increasingly apparent that neither will fossil-fueled vehicles. And far sooner than we might imagine if the bods at Silicone Valley have their way.

Only this morning my newspaper announced that India has joined the growing list of countries pledging to be electric only. By 2030. Only 12-years away.

It seems that all too soon for us petrol engine addicts the gratifying, sometimes spine tingling aural assault of an internal combustion engine soaring to maximum revs will be a thing of the past.

Doom and gloom at the predictions of oil wells running dry and opprobrium from the Greens has nagged at us petrolheads for many years now and we have perhaps become inured to it, but the pressure is becoming more intense to go electric and embrace a world ruled by Elon Musk.

Even more worrying is the possibility that we might be approaching the evolutionary tipping point when we witness the end of the steering wheel, and 'hands-on' motoring becomes a quaint piece of history. Will our grandchildren marvel at driving as 'Really weird! Why would you want to do that?' or, 'Was it scary to actually steer a car, grandad?' (Or, as we will all be gender neutral soon, 'grandthing'.)

As our motorways become ever more crowded, the pressure is mounting to completely remove us humans from the driving experience. Grudgingly I'm

beginning to think that in some circumstances they might be right. There is no fun or satisfaction whatsoever in sitting in a rush-hour bumper to bumper convoy with the odd undertaking kamikaze looney bobbing and weaving across lanes in a life-threatening attempt to gain a couple of car lengths.

The inevitable logic of the autonomous car is the absence of hands-on controls. The transportation vehicle ceases to be a 'car' and becomes a mobile sitting room, even a bedroom – perish the thought of that.

Volkswagen has already shown their concept pod – with a name that for vehicular inappropriateness outshines Sharan – Sedric. Nothing could be less 'visceral' than a machine called Sedric.

'Rubber duck. We have a convoy' sang C W McCall in 1978, relating the

tale of a trucker CB-ing other truckers as they motored west trying to avoid the attention of the 'bears'. Those truckers will soon be redundant, the convoys of the near future formed by autonomous trucks electronically 'hooking' on to each other. The technology is there already – Elon has shown a prototype. (Other makes will soon be available.)

A 'robotruck' is already hauling Frigidaire refrigerators the 650 miles between El Paso, Texas, and Palm Springs, California. Currently a 'driver' goes along for the ride but the objective is to eventually dispense with the human altogether.

Will our motorways become the Tarmac equivalent of a railway track? An endless train of autonomous pods programmed to travel at a set speed at a regulated distance from each other until we 'uncouple' at our destination's nearest sliproad?

If in the future we are going to let our cars do the driving what worth will current brand reputations be? Porsche has built its brand primarily on performance but the autonomous

car will be programmed to play safe, it won't be putting its electronically controlled foot down for a brief adrenalin pumping pulse quickening thrust in the back – ever.

If we are going to be moving around in mobile living rooms, in-car comfort and entertainment will be the most important factor in choosing your pod. Porsche hasn't much of a reputation in the furniture market, or the electronics market, or the games console market. Maybe a Sony pod will make more sense than a Porsche pod. Google have a steering wheel-less prototype running. Would an Apple iPod-pod have more appeal than a Porsche-pod? For a whole load of iPhone addicted kids growing up now it just might. The mighty Kodak, once synonymous with photography, was destroyed when it missed the digital boat. How will Porsche fare in pod world?

Oh dear. I've worked myself into a fit of depression. I think I'd better pop out to the garage and rev up a few motors while we still can. **CP**



Perish the thought that this should be the future of our hobby, says Mallet. We agree...

## “REV UP A FEW MOTORS WHILE WE STILL CAN...”



# RESTORATION

*Design* EUROPE



**QUALITY PORSCHE  
AUTOMOBILE PANELS**

**[www.restoration-design.eu](http://www.restoration-design.eu)**

A. Plesmanlaan 22, 9615TH Kolham, Netherlands  
Tel: 0031 (0)50-5490085 | Fax: 0031 (0)50-5490087 | Mob: 0031 (0)6-53945104  
Email: [info@rescue-911.nl](mailto:info@rescue-911.nl)



# ROBERT BARRIE

THERE'S BEEN PLENTY OF DOOM AND GLOOM IN CERTAIN CORNERS OF THE CLASSIC AND HOT ROD SCENE ABOUT POSSIBLE CHANGES IN LEGISLATION DUE TO TAKE HOLD IN 2018...

Robert Barrie is a classic Porsche enthusiast through and through. As well as competing in historic events with a variety of early Porsches and organising track days, he's also a purveyor of fine classic automobiles



In the UK, most cars over forty years old will be exempt from the annual MOT test later this year. Hurrah, you might say. Three cheers for the good people behind the change. Not a bit of it. The reaction has been anything but positive. There has been concern, confusion and no little criticism. One commentator, whose opinion I would normally value, was moved to say 'I would like to meet the people who write this stuff. Do they wear sleeveless jumpers knitted by their mum, or starched shirts with college ties?'

The upset is because some cars will not be covered, including some covered by the current pre-1960 provision. Owners will need to confirm their cars have not been subject to substantial change and are vehicles of historic interest.

Now, apart from a few nerdy collectors, most of us like to mess around with our cars and may even modify them. They are a bit old and slow, after all. But how substantial does change have to be for it to amount to substantial change?

That is the question and what follows is a personal opinion rather than a definitive answer. I am not qualified to provide the latter. First, common sense suggests that if change is sufficiently substantial then the vehicle is no longer historic. It may be of interest, but it's not of historic interest.

You don't make a historic car by building a new and very different one around an old chassis plate. There is an established registration process involving an eight-point test that replica-builders and the like go through and it's not changing. It's possible it might be enforced more actively, but that's a separate issue.

At one point, there was a suggestion that a similar test could be used to determine substantial change in the MOT context, but that has been withdrawn. The two processes – registration and testing – will remain separate. There was also a suggestion that a power-to-weight ratio test might be applied in the MOT context. That too has been withdrawn. The most recent guidance is reassuring, if less than completely clear.

It suggests that a car has been subject to substantial change if what it describes as the technical characteristics of the main components – the chassis and bodyshell, the axles and running gear, and the engine – have changed in the last thirty years. Consistency might have pointed to the last forty years, but never mind.

The notes do not actually say so, but the idea is presumably that substantial change under any one of the headings is sufficient to constitute substantial change overall. Some further detail is provided. On the chassis and bodyshell, replacements of the same pattern are allowed. That is probably of limited direct relevance to our cars. On axles and running gear, a change in the type and/or method of suspension or steering is likely to constitute substantial change.

On engines, alternative sizes of the same basic engine are allowed as are optional equipment engines. That is more relevant and, unless I am missing something, relatively permissive. The notes also say changes made because original parts are no longer available may be allowed, as may changes made during a car's production or within ten years of it ending, when it was still in general use. On axles and running gear, changes to improve safety or efficiency may be allowed. Again, all relatively permissive.

The advice is that anyone unsure if a change is substantial or not should consult an expert. There's an old joke that says if you put six experts round a table you should expect to hear at least seven views. As a certified and paid-up non-expert, I would expect most cases to be clear-cut and most of our cars to comply.

The small number of judgment calls required will be just that – judgment calls. To be more specific, I reckon it's probably consistent with the guidance to take an earlier 356 up to Super 90 or SC spec, but possibly not beyond. Similarly, I reckon it's probably consistent to take a pre-'73 911 up to 2.7 RS or even 2.8 RSR spec,

but possibly not beyond. Those are the sorts of changes that were made in production by the factory or in period by enthusiasts. It's what most of us have continued to do ever since. To me, the cars remain historic. The dividing lines are arbitrary, of course, but they have to be drawn somewhere. In the last example, I have done so before the 3.0 RS and RSR. Others can and will disagree. The cases of four-cylinder 912s and 914s fitted with six-cylinder engines are also interesting. I reckon they are probably okay, too.

In any case, what's the worst that can happen? It may be that your enjoyable and well-built hot rod still needs an MOT, just as it does at present. It's really not a big deal. In time, you will get over it. If my mother had knitted me a sleeveless jumper I would be wearing it now. I'll have to make do with my starched shirt and college tie instead. **CP**



Changes in MOT legislation – and that surrounding registering vehicles of historic interest – has thrown the cat among the pigeons in some classic circles, but we should be safe, says Robert

## 'IN TIME, YOU WILL GET OVER IT...'



## Teardrop Lights As Original for 356B and 356C

Proper Markings  
Concours Correct  
Complete Assemblies

**Red / Red**  
644-631-403-00  
644-631-404-00

**Red / Amber**  
644-631-403-10  
644-631-404-10

**Your Choice | \$87.50**



# Stoddard.

## Your Trusted Parts Source — Since 1957.



### Early 356 Bumper Guards

Our Production  
Plated or Polished  
644-505-031-02  
644-505-032-02  
From \$222.30



### Indoor Soft Car Covers

Custom Fitted  
For 356 through 991  
SIC-730-05 shown  
\$189.99



### Nose Panels

Our USA production,  
includes fog light bracket,  
NLA-503-011-04 Right  
NLA-503-011-03 Left  
356B T5 shown  
\$598.50



### Pre-A Pedal Cluster Mount

With Cross-Shaft  
and Bushings  
356-49-065-1  
\$1091.54



### Floor Pans

For 356 911 914  
NLA-501-052-00  
NLA-501-053-03  
Early 356 shown  
From \$147



### Door Handles

For 356 through 911  
SIC-531-061-10-SET  
Early 911 912 shown  
\$279.00 per pair



### Stoddard/Hawk Brake Pads

Front and Rear Fitments  
for 356, 914, 911 and 912  
S-Caliper Part Number  
SIC-351-951-OE  
\$54.29



### Longitudinals

Exclusive Stamping  
356A through 356C  
NLA-501-017-00  
NLA-501-018-00  
\$65.10



### Upper and Lower Seat Rail Sets

356 through Early 911  
NLA-521-033-00 shown  
\$328.95



### Complete Dash Knob Sets

Black, Ivory, Grey  
and Beige Available  
NLA-552-KNO-GRY shown  
\$528.32



### Striker Plates

Concours Correct  
Pre-A through Late 911  
SIC-531-701-01  
SIC-531-702-01  
911 1965-1968 shown  
\$49.96



### Pedal Boards

356 911 912 914  
SIC-551-063-41  
1968-73 Targa shown  
\$89.05

**Stoddard.com**

**NLAParts.com**

Highland Heights, Ohio 44143 USA 800 342 1414

Reno, Nevada 89431 USA 800 438 8119

Stoddard Proudly Distributes These Great Products





# LETTERS

GOT SOMETHING TO SAY? NEED TO EXPRESS AN OPINION ON THE CLASSIC PORSCHE WORLD? WELL, HERE'S YOUR CHANCE...

WRITE TO THE EDITOR,  
CLASSIC PORSCHE,  
1 THE ALMA BUILDING,  
BREWER STREET DAIRY BUSINESS PARK,  
BREWER STREET,  
BLETCHINGLEY,  
SURREY RH1 4QP.  
E-MAIL CLASSICPORSCHE@CHPLTD.COM  
PLEASE INCLUDE YOUR NAME AND  
FULL POSTAL ADDRESS

## EUROPE BOUND

First of all, I'd like to say how much I enjoy your magazine. Over here in the USA there is nothing like it, our Porsche magazines preferring to 'mix and match' old and new, which I find irritating as I'm not very interested in reading about the latest Porsche SUVs or hybrid supercars. For me, a Porsche has to have an air-cooled engine in back!

But I digress, for the reason I am writing to you is to ask if you know of any good events in the UK and Europe which would be worth adding to our itinerary. My wife and I have decided, now that I am retired, to have a vacation of a lifetime, taking in as many of the significant events as we can, in between the usual sightseeing, of course! After all, how can an American visit London without stopping off at Buckingham Palace?

Our tastes are many and varied, so don't mind a mixture of museums, shows, races – anything which will appeal to a Porsche lover. We aim to be in Europe for a few months, arriving sometime in March or April.

Many thanks for any suggestions and, who knows, maybe our paths will cross?

**John Coltrane, via E-mail**

*Keith Seume replies: There's quite a lot going on this year, so you won't have any problems finding things to do. Plus, of course, you will need to head down to Stuttgart to check out the Porsche Museum. And while you're there, visit the Mercedes Benz Museum and, if at all possible, the Sinsheim Museum. It is breathtaking.*

*As far as events are concerned, you could do worse than add some of these to your 'to do' list:*

*Goodwood Members' Meeting:*

*17th–18th March*

*Techno Classica Essen:*

*21st–25th March*

*Retro Classics Stuttgart:*

*22nd–25th March*

*356 International:*

*3rd–6th May*

*Simply Porsche (Beaulieu):*

*3rd June*

*Le Mans Classic:*

*6th–8th July*

*Goodwood Festival of Speed:*

*13th–15th July*

*Silverstone Classic:*

*20th–22nd July*

*Brands Hatch Festival of Porsche:*

*31st August–2nd September*

*For us, Le Mans Classic is a 'must do' – so make sure you go to that one if you can. See you there if you make it!*

## TYRE ADVICE

I am nearing the end of the rebuild (I hesitate to call it a restoration, as it is more an exercise in keeping it on the road) of my 1967 Porsche 912. In the past, the car was fitted with some rather non-descript 165x15 radial tyres, which are clearly past their best. It is time, I think, to treat it to some new tyres, but what size? The steel wheel rims are marked 5.5Jx15 (I'm guessing they're not the originals) so am pretty sure I could go up in size.

I notice that your own project car has 185/70x15 tyres fitted – do you recommend them over something more modern, such as a 195/65x15 tyre? I am after a combination of good looks and good handling.

**Graham Jones, via E-mail**

*Keith Seume replies: Hi Graham. You're right, our car does have 185/70x15s installed (Blockleys at present) but in the past we've also run 195/65x15 Vredesteins. In terms of grip and wear, both have proved to be pretty much equal, but for us the classic profile looks far better suited to an early car. Modern tyres tend to have a more square profile which we think looks a little at odds with the character of an early 911/912. Yes, you can save quite a bit of money 'going modern' but in our opinion you'll be better off going classic...on your classic.*



*If you're visiting Europe this year, you can't miss out on a trip to Le Mans Classic. You'll discover sleep is very underrated...*

## “WE HAVE DECIDED TO HAVE THE VACATION OF A LIFETIME...”

## MARATHON MAGIC

I greatly enjoyed reading the book extract you published in your latest issue on the subject of the record-breaking attempt at Monza. Reading this rekindled some old memories from when I lived in Italy with my parents.

My father was a track worker at Monza and came home very excitedly one evening to tell me that Porsche had showed up ready to have a crack at a world record. None of the locals reckoned they had a chance of surviving on Monza's rather tired circuit, my dad included. How wrong they were!

I wasn't supposed to get into the track, as it was closed to the public during the attempt, but being a schoolboy at the time, I wasn't going to let a little detail like that stop the fun. With a friend, I cycled to one of the more remote parts of the track and snuck through the fence to take up position near the banking – your opening photograph must have been taken very close to where we were hiding.

I will never forget the sight and sound of the tiny 911R as it tore round the circuit to this very day. Thanks for the memories.

**Antonio Carlucci, via E-mail**

*Keith Seume replies: What a great story! Did you happen to have a camera?*





**HERITAGE**  
PARTS CENTRE

CALL: +44 (0) 1273 444044  
ONLINE: [WWW.HERITAGEPARTSCENTRE.COM](http://WWW.HERITAGEPARTSCENTRE.COM)

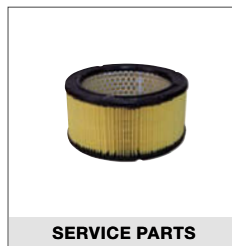
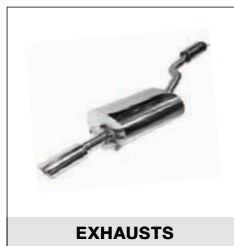
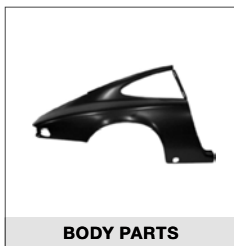

EXPERT ADVICE • 3000 PORSCHE PARTS ONLINE • FREE DELIVERY OVER £35\*





# A CLASSIC PORSCHE PARTS STORY

your partner for: Porsche 356, 911/912, 964, 993



**JOMAPARTS.COM**  
porsche classic parts

Gefusilleerdenlaan 29 - 9600 Ronse, Belgium  
T +32 55 21 30 13 - F +32 55 20 70 69  
info@jomaparts.be - www.jomaparts.be

Nederlands   Français   English   Deutsch   Italiano   Português

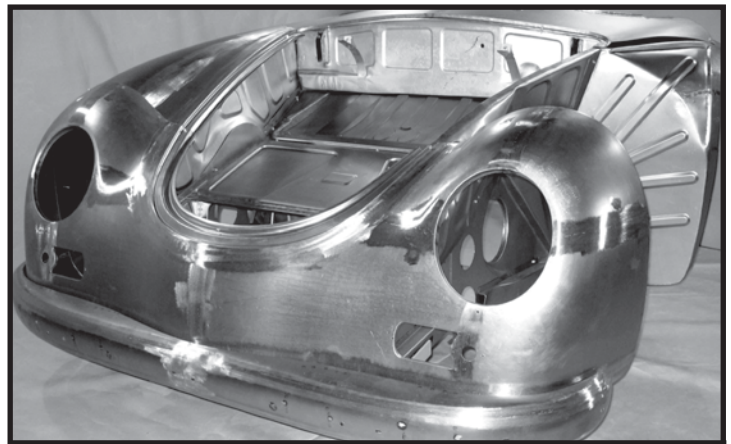

www.356panels.com

**Trevor's Hammerworks, Inc.**

440-953-0501 440-602-9885 Fax

# PORSCHESHOP.CO.UK

NEW MOBILE-FRIENDLY WEBSITE

SHOP BY MODEL

901

911

912

914

964

993

RSR

944

924

CARRERA/GT

WORLD LEADERS IN PARTS DIRECT PROVIDING O.E.M. SUPPLIED PARTS WHERE APPLICABLE AND BRANDED AFTERMARKET PRODUCTS

## SHOP CLASSIC PARTS

Alloy & Carbon Interior Trim

Badges & Decals

Body Repair Panels

Body Seals

Brake Parts & Components

Clutch, Gearbox & Flywheel

Coloured Dial Kits

Engine Components

Exhausts

Lights & Lamps

Locks & Handles

Service Items

Suspension

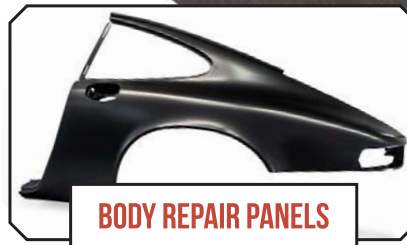

**BODY REPAIR PANELS**



**LIGHTS & LAMPS**



**MECHANICAL PARTS**





Info@SMCparts.com • www.SMCparts.com • Pasadena, California • +1.626.844.4616

We ship hundreds of orders overseas weekly using USPS, UPS, and FedEx. Delivery time as quick as 4-5 business days.



**Dash Knee Pad & Door Panel Top Set**  
911/912/964/993 (69-98)  
911.554.SET \$727.27



**Trunk Lock Repair Kit,**  
914 (70-76)  
914.512.913.K \$73.29



**356 Pre-A & 356A  
Bumper Guards**  
\$238.50 - \$298.00



**Bursch Muffler**  
912 (Quiet Street)  
BX 1203 \$316.25



**Steering Wheel**  
356B/356C  
644.347.084.05 \$1,175.00



**Luggage Rack  
Leather Strap Set, Tan**  
SMC.200.006 \$169.87



**Seal & Rubber Restoration Kit,**  
911/912 Coupe (69-73)  
SMC.000.892 \$1,006.36  
*Other models available!*



**MAXILITE Fuchs Style Wheel, 11" x 15"**  
911/930 (77-89)  
OE Finish MX111015M \$410.00

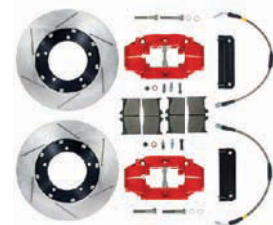

**StopTech Big Brake Kit,**  
Rear, 911 (69-89)  
SMC.82.785 \$1,795.00



**Early 911S Registry**  
2018 Calendar  
SMC.012.04 \$30.00



**Spark Plug Wire Set,**  
911/930 (74-89)  
911.609.010.01 \$82.85



**PMO Carburetor Set,**  
911 (65-73)  
SMC.911.500 \$4,714.29



**Complete Rebuilt Engine**  
2.7 Liter, 911S  
901.101.101.7R \$13,500.00



**Front Caliper Set,**  
Early 911S (67-68)  
SMC.351.975.SET \$381.54



**Tool Kit, 356C**  
SMC.721.020.04 \$572.51

### KEY BY CODE PROGRAM

Call or visit us online for pricing and details



Try our new key service dealing exclusively with Porsche automobiles. Our excellent customer service, large selection of genuine, NOS and aftermarket keys will simplify the process for requesting key services.

## Free shipping on orders under 3 pounds, \$75 minimum

Mention Classic Porsche in the order notes and we'll refund the shipping on qualifying orders. *Restrictions apply.*

GENUINE • REPRODUCTION • NOS • AFTERMARKET • OEM • ORIGINAL



1055 East Walnut Street • Pasadena, California 91106 • United States





# FRIENDS REUNITED

What better way to advertise a historic sports car than to reunite it with some of its previous owners, and in what better setting than at Goodwood? That was the inspired idea of Mick Pacey whose Export 56 company has maintained and restored many Porsche 356s over the last 25 years. During this time Mick has been involved with a number of the four-cam models including this very rare UK-delivered RHD Carrera 2

Word: Kieron Fennelly  
Photos: Antony Fraser







**T**hese days, in Porsche parlance, 'Carrera' simply denotes the base 911, but in 1955, when the company presented its first road going special, the Porsche Carrera, named after the company's successes racing in Mexico, it was one of the fastest production sports cars on the market. The engine which was at the heart of the Carrera is often referred to as the 'Fuhrmann' four-cam after its genitor, an exceptional Porsche engineer.

A complex, intricately constructed flat-four, it was immensely powerful, capable of revving on its roller bearings to 7500rpm and producing 110bhp. Fitted in production 356s it remained in virtually race tune and, with standard final-drive ratios, offered a top speed of 120mph, which put it in the territory of the Jaguar XK140 or Mercedes Benz 300SL, cars with twice the cubic capacity, but none of the Porsche's agility. By 1959, when production ended, continuous development had pushed output to 115bhp and added a good 5mph to the maximum speed. After a hiatus, Porsche launched a Mark 2 Carrera, based on the 356B which, with its new two-litre flat-four, was faster and offered considerably more torque.

The Carreras were expensive cars, though: most went to America, with little more than a dozen of the first generation arriving in Britain; there were even fewer of the Carrera 2 which, by 1963, when the first RHD cars became available, had to contend with the rakish E-type Jaguar, which cost little more than half the duty-paid price of the Porsche.

One Carrera 2 that did appear in UK distributor AFN's showroom on the London Road in Isleworth was 292 NOJ, and in May 1963 it became the property of a Mr MJ Hawley. No details are known of this first owner except that, in 1966, he traded it in and the next proprietor was a certain Sydney

**“LIKE AN  
AIRCRAFT, IT WAS  
COMMITTED TO  
THE JOB IN  
HAND...”**

Jordan. An artist and illustrator, Jordan's main claim to fame is that in the 1950s and '60s, he drew and wrote the Jeff Hawke cartoon strip in the *Daily Express*. Today a spritely 90 years old, Jordan explains that if comic strips have largely gone the way of all flesh (though not in France or Italy), this is because 'people don't have time to read them.'

He never regarded Jeff Hawke as mere entertainment, though: 'I was trained as an aero engineer in the RAF. I was very interested in technology and like a lot of people then was fascinated by the space race: I tried to reflect this modern technical future in Jeff Hawke. The strip was accepted by the *Express* because the proprietor, Max Aitkin, had been a Battle of Britain pilot and the war references appealed to him.'

A keen motorist, Jordan claims he was never a talented driver, though he liked to take part in sprints and time trials. He bought himself an E-type Jaguar, 'but it fell apart.' He was attracted to the 356: 'It looked like a tarted up VW, but it made sense to me. It was spartan, but functional, as if it had been designed from the inside out, like a plane, and like an aircraft it was committed to the job in hand. NOJ was my third Porsche. It cost me £2000, and like the others I drove it in and out of London every day. Porsches were very dependable. I went all over Europe and even down to Gibraltar with the Carrera. That was an adventure – we were following the coast beyond Malaga and had to drive on the beach at some points because the road had simply disappeared. Then coming back we were rushing for the ferry when not far from Calais something went bang. An elderly





*Above: Sitting squat and purposeful in the Goodwood paddock, the Carrera 2 is one of but a handful of RHD examples sold in the UK*

Frenchman in a 2CV towed us to the port at what seemed like hideous speeds; people must have been thinking, “why doesn’t that Porsche overtake the Citroën instead of following so close behind it?”

Sydney admits he drove Porsches in something of a state of ignorance, acknowledging they were fast cars, but requiring cautious handling especially when it was wet: ‘The tail wagged the dog,’ as he puts it. The full extent of this ignorance became apparent when he saw how club racer Nick Faure threw his 356 about: ‘It reminded me of how you had to fly the Sopwith Camel. The weight was all concentrated at the front and the torque from the engine meant it always turned to the left and you had to anticipate and counteract this. That’s what Nick did in the 356: he’d turn away from a bend then turn into it and balance the car. I’d seen him do this racing a Mini Cooper at Castle Combe without knowing who he was.’

The pair met outside a fish and chip shop: ‘I emerged,’ recalls Sydney, ‘to see another 356 parked behind mine. I was amazed: you almost never saw other Porsches.’ The owner was a young fellow called Nick Faure and his recollection is that Sydney seemed slightly at a loss, saying

that he was trying to buy a bottle of milk to which Faure replied that he lived locally and his mother would have one if Jordan would care to follow him.

‘Well I had the devil’s own job of keeping up with him,’ exclaims Sydney, ‘but when I did get to his house we got talking and I realised that he was also something of an artist. I was at a stage where I needed some help with Jeff Hawke and that’s how Nick got his start in Fleet Street. (Faure would go on later to illustrate the long-running ‘Driving with Paddy Hopkirk’ feature in the *Daily Mirror*.) He also garaged his ex-Elford 911 GVB 911D at my house.’

‘Nick made me much more aware of the Porsche’s potential and it informed my driving: I also brought the idea of the tail that wagged the dog and the Carrera into the comic strip over ten years and I think in a way I immortalised it. It’s wonderful to see 292 NOJ today – in better condition than when I owned it – a natural survivor.’

Sydney Jordan sold the Carrera 2 in 1969 to help pay for a house purchase. The new owner was Robin Prior who still possesses his original bill of sale for £1325. He is clearly delighted to be reunited with his old mount: ‘I saw that Export 56 was selling it and I was fascinated to see it again – I

*Below: 356B ‘nipple’ hubcaps hide the Porsche-developed annular disc brakes that preceded the more conventional design used on the later 356C models*





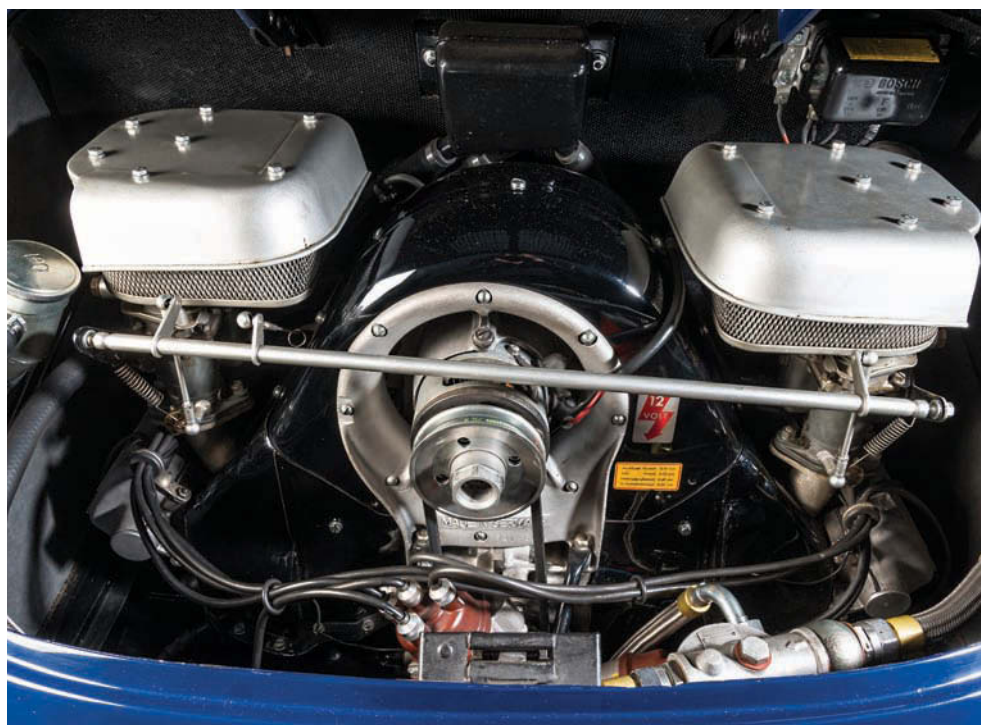

*Above, left and right: 'Carrera 2' badging is the only clue to what lies beneath the deck lid. The 1966cc four-cam engine produced a very useful 130bhp at 6200rpm, with peak torque at 6000rpm*

owned NOJ over 40 years ago and I bought into something that is now a legend, but to me the Carrera was just a piece of fun. My friend John Piper, later chairman of the PCGB urged me to buy it.

'I had to get used to its foibles – starting for example: depress the accelerator twice when hot and six times when cold. Get the sequence wrong and it would keep you waiting fifteen minutes before it fired. For me the Carrera recalls a wonderful time when driving was so much fun.

'I remember driving from London to Stratford in just over 90 minutes. From Woodstock to Stratford I had an Alfa Romeo GTV right behind me, and when I stopped at a petrol station he leapt out and I was expecting the worst but, incredulous, all he could utter was "what the hell have you got in the back of it? I couldn't catch you!"

'The Carrera was never a straightforward car: in 1971, I felt it twitch as I drove on to Waterloo Bridge, stopped and discovered that the oil cooler had fractured and sprayed the tyre. If I hadn't felt it at that moment, I would surely have lost the rest of the oil and destroyed the engine. I remember too

how the fan belt came off and the pulley shattered and broke one of the distributors: it was late Thursday before Good Friday and I was in deepest Dorset.

'I managed to phone AFN and Alan Smith who was AFN's stock controller drove down the very next day and repaired the car so that I could continue – marvellous service. It was a fragile car, but immense fun: there was always a special kind of excitement when you got into it. I think the fact that I have kept the handbook and the receipt shows I was more attached to it than I realised.

'Would I want the Porsche back? No – it was a very happy time in my life and I would be afraid of disillusioning myself, of discovering it was not as I remembered. Then my children were born and I was hardly using the Porsche so in 1978 I sold it to John Piper.'

Piper drove NOJ until it went to Australia and to a collector. A subsequent antipodean owner undertook a full body and interior restoration over several years, retaining the original Bali blue paint scheme and black upholstery. Specialist Peter Hardt rebuilt the engine fitting pistons from

## So what is a Carrera 2?

Announced at the Frankfurt show in 1961 with production beginning the following April, the Carrera 2 proved, as Karl Ludvigsen puts it, that Porsche was not ignoring hairier versions of the 356B. By this time it was also an open secret that a new Porsche was on the way, nevertheless the 356 still had life in it and Porsche had a new two litre engine up its sleeve.

The Carrera appellation indicated that this was a four cam unit, not the overhead valve unit of the stock 356, and the 2 denoted the capacity. This engine was a logical development of the original Fuhrmann engine which had begun at 1498cc and was subsequently bored out to 1588cc. By now Ernst Fuhrmann had moved on and Carrera 2 development took place under technical director Claus von Rücker. Widening the bore further to 92mm and lengthening the stroke to 74mm raised capacity to 1966cc, while keeping the Carrera inside the two-litre class. There were no changes to the basic architecture of the engine but the two-litre was significantly wider and a higher efficiency oil pump was fitted to cool the largest production engine Porsche had so far built.

Zuffenhausen developed the two-litre for good competition reasons: its smaller engines were increasingly hampered by lack of torque. Prototype Carrera 2s were subjected to extensive road testing during the winter of 1960/61 and the engine really proved its worth on the Targa Florio in April 1961: Moss, in the lead with a Camoradi-entered RS 61 shared with Graham Hill was running away from Gendebien's Ferrari until the Porsche lost its differential oil about five miles from the finish; two more RS 61s finished second and third.

The next step was to install this engine in a production car: in standard form the Carrera 2 with a 9.5:1 compression ratio developed 130bhp at 6200rpm, but 162Nm at 6000rpm compared with the 120Nm at 5000rpm of the 1588cc four cam unit. For competition, the Carrera 2000GS and the lightened 2000GT versions had a 9.8:1 compression ratio and developed 140bhp at 6200rpm and 155bhp at 600rpm, respectively. The final incarnation of the Carrera 2 engine was in the 904, originally designed with the new flat six in mind, but which initially used the four cam engine largely because of availability of spares. In road trim the flat four 2.0-litre 904 GTS developed 155bhp, but an impressive 180bhp in full race tune.

The Carrera 2 was also the first Porsche to feature disc brakes: Zuffenhausen had resisted these for many years, claiming its relatively light cars were adequately served by alloy drums, but in fitting its own design of disc brake to the Carrera, Porsche was effectively yielding to progress. Significantly, the 911, a heavier car than the 356, had disc brakes front and rear from the outset.

Between April 1962 and spring 1964, Porsche built 426 Carrera 2s, 310 based on the 356B and 126 based on the 356C. There were a dozen RHD cars, ten of which are recorded as coming to the UK: 292 NOJ was the fourth Carrera 2, registered in April 1963; 5 HOT, the fifth Carrera imported, was the lightened Carrera GT for RAF pilot and amateur racer Dickie Stoop.





the 904 which reportedly raise power to 160bhp.

In 2008 NOJ went to Stewart Webster, a renowned Australian 356 dealer who added the Carrera to his collection. In 2013 he decided to retire and sell off his cars at which point NOJ returned to the UK and its current owner.

Given that NOJ has spent its last thirty five years in collections, the odometer reading today of 73,500 could well be accurate, especially as its 55 years are comprehensively covered in its copiously documented service history.

#### On the road

Would NOJ fail to live up to memories of nearly half a century ago, as Robin Prior fears? Today's traffic means you certainly

could not race up the A34 as he did much, less subject such a thoroughbred to a daily London commute as Sydney Jordan used to. Here at Goodwood however we have an opportunity to see whether the passage of time has diminished the magic of this Carrera 2.

Compared with the early 911, the 356 cabin feels intimate, almost cramped: the steering wheel is close and the dashboard is the functional panel that Sydney remembers, but still with a beautifully engineered finish.

The leather seat is remarkably comfortable and the long gearstick falls exactly to hand. Indeed, though one's knees might be slightly more bent than usual, the driving position suddenly feels right and one is reminded that legendary oneness of driver and machine goes back to the very beginning

*Above: There was nothing pretentious about the Carrera 2, its restrained Germanic styling contrasting with the more outrageous look of its contemporary rival, the E-type Jaguar*

*Below: Compared to the later 911, the interior of the Carrera 2 feels cramped, but its leather seating and woodrim wheel give a period charm that is without equal*

## “NOJ HAS SPENT ITS LAST 35 YEARS IN COLLECTIONS...”







*Above left: Sydney Jordan (foreground) bought the Carrera 2 in 1966 from AFN. He was the second owner. Alongside him is Robin Prior, owner number two, who acquired 292 NOJ in 1969*

*Above right: Nick Faure, second from left, had a major influence on Sydney Jordan's thinking with regard to how Porsches need to be driven. Aside from his skills as a driver, Faure was a successful Fleet Street artist, as was Jordan*

### **Ernst Fuhrmann – the man behind the four-cam**

Viennese Ernst Fuhrmann was one of Ferry Porsche's first postwar employees, joining the *Konstruktionsbüro*, then based in Gmünd, in 1947. The pair worked together on several major projects, including the Cisitalia 360 racing car, the complex 1500cc supercharged flat-12 with four-wheel-drive. In 1952, concerned to get more power from the VW-based flat-four, Ferry asked Fuhrmann to look at alternatives. The quad-cam engine, much of its thinking derived from the Cisitalia, was the result. Fuhrmann's ambitions, however, went beyond what Porsche could offer and in 1956 he moved to engine components maker Goetze, shortly to become technical director. In 1971 he was recruited back to Porsche to become the newly restructured company's first managing director. Though he established the 911 as a serious racer with first the Carrera RS and then the Turbo, his increasing emphasis on developing the transaxle 924 and 928 at the expense of the 911 would ultimately lead to his ignominious departure from Porsche in 1980.

with Porsche. The absence of seatbelts is of course historically accurate though it feels odd not to be strapped in, but once underway, this is quickly forgotten.

The Carrera has been warmed up so two prods on the accelerator should suffice, but on this cold day it seems reluctant to catch. Then just as you begin to think about cursing these temperamental thoroughbreds it splutters

ortly into life and settles with a businesslike idle. The handbrake is not immediately visible beneath the fascia, but the clutch feels relatively light, the gear lever slips into first and we are away. Throttle response is immediate and clearly this is a highly tuned engine, but initial impressions are how refined and smooth the Carrera is. Clutch and gearchange work beautifully together: the four ratios are by







today's six-speed standards spaced well apart, something around 30mph available from first and 60mph and 90mph from second and third respectively, which means quite a drop in engine speed between changes. The four-cam makes up for this with impressive bottom end torque, pulling away without protest from well below 2000rpm, surprising performance from an engine which has the same output as the lightened Carrera 2 GT.

Porsche used to advise drivers against letting the revs fall below 2000rpm to prevent plug fouling and other maladies of over-rich combustion. At about 4000rpm the engine takes on an urgent note and, almost as if a second choke has opened, the rev counter needle swings dramatically before your eyes: maximum torque is reached at 4700rpm, maximum power at 6200 and these engines will rev on to 7000.

We limit ourselves to 5500rpm, which corresponds with about 95mph on the Lavant straight. At these speeds, the Carrera feels tremendously secure, responding firmly to braking for Woodcote and steers round this long bend with all

the precision one expects from a Porsche.

To add to the sense of occasion Mick Pacey has also brought along his 356A-based racer, a lightened car with roll bar and bucket seats, its 1.6 pushrod tuned, he says, to about 110hp. A veritable bomb, it tracks the Carrera 2 through the bends at Goodwood, but despite weighing perhaps 800kg to the Carrera's 1010kg, the heavier car surges away rapidly under acceleration.

This is very apparent leaving the chicane, the only point at Goodwood where second gear is used and the greater torque resources of the two-litre mean it is suddenly 50 yards ahead.

Almost the final development of the 356, the ultra rare Carrera 2 was a superbly resolved

car. 292 NOJ is a particularly fine example, yet despite being tuned to competition levels its mechanical sweetness, handling and ergonomics make it extremely rewarding to drive. It is little wonder that today these wonderful Porsches are so sought after. **CP**

*Above: Sydney Jordan recalled the Porsche's tail wanting to wag the dog. By watching Nick Faure at work, he discovered the secret of how to drive the Carrera fast*

**Contact:**

*We are grateful to Export 56 Ltd for co-ordinating this reunion of 292 NOJ with its previous owners. 292 NOJ is now for sale at Export 56. [www.export56.com](http://www.export56.com)*

*Below left: Large-capacity long-range fuel tank was part of the Carrera specification*

*Below: Robin Prior still owns the original handbook and his bill of sale for the car*

**“AT ABOUT 4000RPM, THE ENGINE TAKES ON AN URGENT NOTE...”**

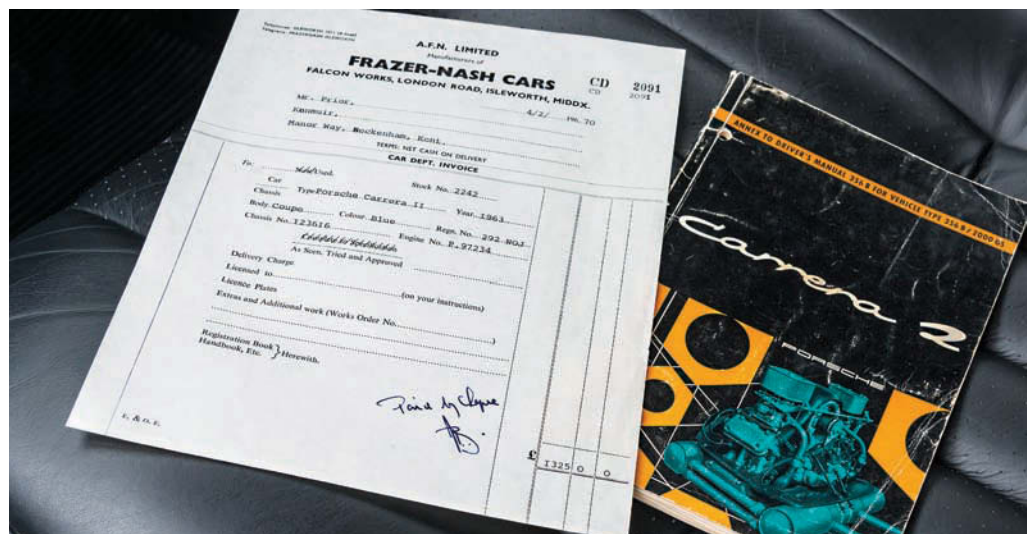





# - Friends Reunited -

## PORSCHE 356 CARRERA 2 GS COUPÉ

We have created a special film on this month's cover star.  
This rare, one of twelve, RHD Porsche 356 Carrera 2 GC Coupé is the subject of  
a short 10-minute film which can be viewed on our YouTube Channel.



SALES | RESTORATION | RACING | SERVICING | STORAGE & TRANSPORTATION

[WWW.EXPORT56.COM](http://WWW.EXPORT56.COM)



Words: Johnny Tipler Photos: Sarah Hall

# FRUIT SALAD DAYS

Born in the flowering of late '60s hippiedom, the 911E represents Porsche's first compromise between work-a-day T and sporting S. We head for the hills in a haze of orange at the wheel of a 1969 example







**T**oo right: Oranges are not the only fruit, as the coming-of-age saga has it, and aptly, this Blood Orange 911E is all about the metamorphosis from hard-core S and kitchen-model T into a more genteel bolide aimed at the enthusiast with a penchant for motoring of a more refined, not to say laid-back, nature. And, what's more, it's pretty fruity in its own right.

So first of all, let's nail down the data. The 911E was in production between 1969 and 1973, and replaced the short-lived 911L – or Lux. The E was intended to be a more comfortable version of the 911 than the austere T and more upscale S model. At the same time, the line-up's bargain basement offerings were the 912 and 914.

The 'E' stands for *Einspritzung* – meaning fuel injection – and the MFI (mechanical fuel injection) system shared with the 911S was developed jointly by Bosch and Porsche themselves, based on the injection system employed by the 906 (Carrera 6) sports-prototype racing car of 1966.

The benefits of fuel injection over carburetors were that it enabled more precise control of the fuel-and-air mixture, as well as equalising the mixture's distribution between the cylinders. Its implementation also coincided with the incoming emission legislation in the USA, which was Porsche's most important market, and which the company was obviously keen to comply with in any case.

The E was fitted with self-adjusting hydro-pneumatic front suspension struts; developed by Boge, the struts combined the functions of springs, dampers and anti-roll bars, whilst automatically adjusting the height of the front of the car to compensate for the weight of luggage carried in the front boot.

These struts were standard equipment on 911E models from 1969 through 1971. However, this innovative design solution may have been a little too smart for its own good, since it appears that, over the years, 911E owners have collectively swapped these hydro-pneumatic items for traditional struts and torsion bars. Both the E and the S also featured a new high-voltage capacitor ignition system, aimed at sorting the spark-plug fouling that affected some earlier 911s.

The 911E was available in coupé and Targa styling, with coupé shells also made by Karmann in '69 and '70 until Zuffenhausen's Porsche Werks were running at full capacity. In terms of numbers built, production in 1969 totalled 954 coupés and 1014 Karmann-built coupés, plus 858 Targas (which at this stage were only available in left-hand drive), and then 1304 coupés and 667 Karmann coupés plus 933 Targas in 1970. These were followed by 1088 coupés and 935 Targas in '71, with 1124 coupes and 861 Targas in '72, and finally 1366 coupés and 1055 Targas in '73. Not many at all, then, in the grand scheme of things, and especially compared with current volumes.

The model years were identified as B-programme in '69 – with production starting in September 1968; C-programme in '70, D-programme in '71, E-programme in '72, and F-programme in '73. The major innovation to occur during the E's lifetime was the introduction in autumn 1969 of the 2.2-litre flat-six engine, achieved by increasing the bore size from 80mm to 84mm.

The E also benefited from the lengthened wheelbase, stretched in 1968 – for the B-programme '69 model year – from 87in to 89.3in, simply by moving the rear axles backwards in the shell, without shifting the engine and gearbox, but lengthening the trailing arms and adjusting the wheel arches accordingly, resulting in a significant increase in drivability and improved handling.

A year later, writing in *Motor Sport* of February 1970, Denis Jenkinson (DSJ – or Jenks) declares of Porsches that, 'It is their manner of doing things that makes them great; the steering is light from a standstill up to its maximum speed, with just the right amount of feedback from the front tyres; at all times the Porsche feels that it has its feet well and truly planted on the ground, and what is more it has its feet spread well apart. You can drive a Porsche as hard as you like and you will not run out of roadholding or stability.' That was 48 years ago, and it's





true enough today, of the classic E at any rate.

By 1973, the writing was on the wall for the classic long-bonnet 911s. It was all change for the '74 model year, with a host of revisions mechanically and aesthetically, as well as re-designations across the model line-up. The impact-bumper look that came in with the 1974 line-up was greeted with a certain amount of derision on aesthetic grounds.

But the new styling and what lay beneath it was imperative for the 911 to enable it to comply with the stringent new US safety legislation, which meant that all cars had to be able to withstand a 5mph impact without sustaining serious damage. But something far more fundamental was afoot, too. Porsches addressed the corrosion issue with zinc-dipped galvanised steel for all body panels, becoming the first manufacturer to offer a six-year corrosion warranty on a car's central bodyshell.

Launched against a Middle Eastern oil embargo, fuel shortages and power cuts, prospects did not look great for the new generation of 911s. Forget the Summer of Love, this was Cruel World reality, and the E was a thing of the past. The G-Programme 2.7 ushered in the 1974 model year, with three versions on offer: the basic 911 (replacing the long-bonnet 911T), the 911S (taking over from the 911E) and the Carrera 2.7

(superseding the 2.4-litre 911S) and using the 210bhp unit from the outgoing 2.7 Carrera RS.

But, turning the clock back, it's always interesting to contemplate how the cars were received in the press at the time; in April 1968, that paragon of racing and road-going excellence, *Motor Sport* magazine advised that, 'once a manufacturer has a series and basic conception that is respected it is a big step to make a radical change. Nowadays the 911 series of Porsche cars are respected throughout the world, just as the old 356 series were, although a few die-hards still have a longing for the old Beetle-like Porsche.'

Interesting that, five years post-introduction, the writer – DSJ – felt it necessary to affirm the model's veracity. But then DSJ had been a fervent 356 owner and enthusiast, and ran an E-type as it was half the price of a 911 (and, as he also remarked, a 911 was half the price of a Lamborghini Miura).

However, being the magazine's top-line racing correspondent, he was completely au fait with Porsche racing history: 'Today, when you drive a 911 you can feel that it is honest and solid in its design and construction, because if it was not it would not stand up to the rallies, races and hill-climbs to which it is subjected by Elford, Rindt, Neerpasch, Mitter and the

*Above: The 911E may not have been quite as powerful as its S sibling, but its performance was enough to impress the likes of respected Motor Sport journalist Denis Jenkinson*

*Below: Interior is said to be 100 per cent original, and there is no reason to believe otherwise. Although it carries a negligible degree of patina with pride, it's as good as you'll find in a near-50-year-old Porsche*





rest. You do not finish the Targa Florio, the 84-Hours Marathon at Nürburgring, the 24-Hours at Le Mans and the 24-Hours at Daytona on luck alone.'

This is something that perhaps we rather take for granted nowadays. Even so, bearing in mind the car's competition pedigree, DSJ remarks that, 'all Porsches are very lavishly and completely equipped, no matter what the mechanical specification.' Again, it's interesting that he regards the 912 and 911T as lavishly equipped, though perhaps compared with the prevailing austerity of mass-produced cars in the late '60s the 911s were all relatively plush. As a matter of interest, the price of a 911E at launch was £3450. Sportomatic transmission was available as an option for all models, priced at £155.

Now we discover how all that stacks up today in the rarefied world of historic air-cooled 911s. Where better to find out than by visiting our old friend John Hawkins at Specialist Cars of Malton, where, tucked snugly in the heart of the mirrored-glass showroom, there's this gorgeous 911E, preening itself with self-satisfaction in amongst the other Zuffenhausen belles, lined up like candidates in a beaten-metal beauty contest.

This one's a 1969 car, powered by the 2.0-litre 140bhp flat-six. It's finished in Blood Orange, and apart from a repaint is amazingly original. For example, even the spare is unused – a proper matching Fuchs wheel with an original Michelin tyre on it (an uninflated tyre-on-rim was also an option at this point in time, with inflator pump). The E is on its correct 15in Fuchs alloy wheels, wearing

Yokohama 185/70 R15s all round.

Its chassis number is 119200532, and the date of first registration is 3rd March 1969. As I've already hinted, whilst it has had a repaint it looks immaculate – and there's certainly no orange peel. People talk in reverential tones of the age-authentic sanctity of patina, but actually it's so clean and tidy there is no sort of patina as such; it's just a lovely example of a '69 911. In spite of its pristine appearance, though, it's had something of a peripatetic career.

The original log book is one of those little green concertina-folding documents, revealing that the original registration was 16 LPF, and it seems to have been first registered in London and then went to Barnstaple, Devon. It then shows up in Keswick in

the Lake District, and then it goes to Brighton in 1991. Amongst the documentation is a certificate of authentication from the factory, and recent history pegs it 20 years ago when it was auctioned by Sotheby's in 1997, where it was bought by specialist Porsche dealer Russell Edmund-Harris in Oxfordshire.

He sold it to its previous owner, Steve Edwards, in '97, and for 10 years it was in a private museum. In 2008, it was acquired by its present owner, ex-Formula 1 engineer and

former Rolls Royce engineer Philip Harnett, who took it from GB to Munich where he worked in BMW's design studio. Just looking through the old bills, it had quite a lot of work done while it was in Munich.

A bit more nitty-gritty. The 911E was delivered in most markets with the 'comfort' package which included velour

**“ALL PORSCHE  
ARE VERY LAVISHLY  
AND COMPLETELY  
EQUIPPED...”**

*Below: Blood Orange, Fuchs wheels and a modest amount of 'chrome' trim – what more can you ask for?*







carpeting throughout and a leather-rimmed steering wheel which, back then in the days of the standard-issue Bakelite rim, was still considered something pretty special, and a mainstay of the accessory shops. The upholstery in our subject car is called Black Pepita, better known as Hound's Tooth, and though quite well worn and a little spongy, the seats are still smart.

Another example of the car's originality are the Irvin seat belts, with long, non-retracting webbing and a curious buckle arrangement that proves to be something of an intelligence test to fasten up. No sane person would contemplate fitting them today and, clearly, they come from a time when seat belts were revolutionary – and not mandatory either.

The steering wheel does feel large diameter with its small rim, compared with modern stuff, but that just adds to the delicacy of the feel of it, especially with the four-spoke horn-ring. The door bins are still operational, and all the brightwork is absolutely immaculate, from the Durant mirror to the radio aerial, the screen surrounds and window frames, the horn grilles and headlamp bezels, and it's also got stainless-steel sill plates. And there's a rear wiper and a sliding sun roof.

Mechanically, the E's Comfort spec also included ventilated brake discs with aluminium calipers, chrome rocker-panel trim,

and gold-coloured script on the rear deck, and it has the over-riders on the front and rear bumpers, as well as the original driver's door mirror. The stickers in the engine bay are all in place, and the fan shroud is in green glassfibre.

The odometer proclaims the mileage is 97,785, so you have to ask the question, what engine work has it had done? There's a full service record since 2008, with its last major service at Cars International, Berkshire, in 2014. A check underneath reveals that it's got newish heat exchangers; but Specialist Cars will warranty it for 12 months, so no worries on that score.

But let's see how it goes. I'm working with snapper Sarah Hall who normally specialises in Autocross photography, but mercifully we confine ourselves to the marvellous B-roads and lanes north of Malton and adjacent to Castle Howard.

Firing up requires a pause for thought. As DSJ observed in *Motor Sport* back in February 1970, 'Fuel-injection calls for different operating techniques, though not different driving techniques. When starting from cold first thing in the morning you pull up a little lever mounted between the seats and on no account touch the accelerator pedal. You turn the starter key and crank the engine over briefly...and the engine is running instantly, but very slowly.'

*Above: The 911E was the most luxurious of the three-model 911 line-up, with the more compliant (but often troublesome) hydro-pneumatic suspension*

*Below, left and right: 2.0-litre 911E engine produced 140bhp at 6500rpm and relied on the new Bosch mechanical fuel-injection, first developed for the race programme. The capacity was 1991cc, achieved using a 66mm forged crank and 80mm pistons*

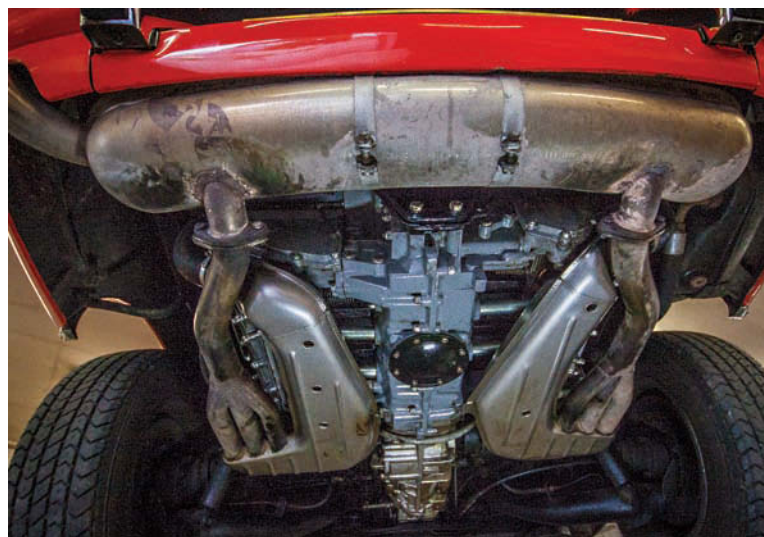
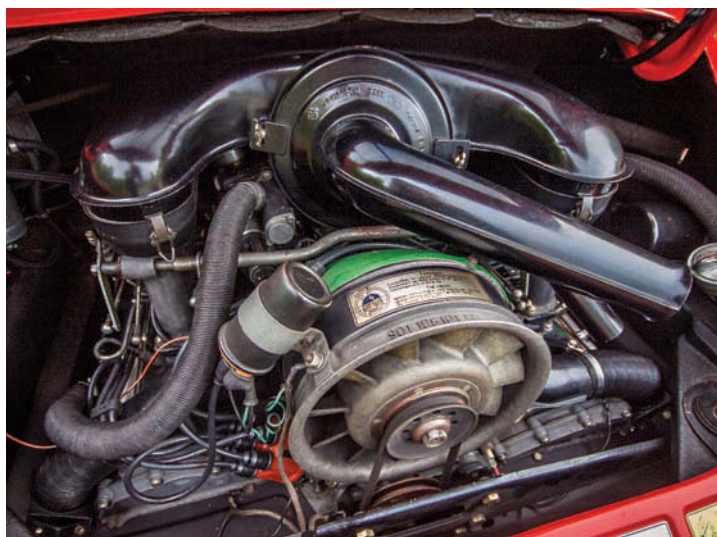





*Above, left and right: Original unused spare wheel can be found under the boot carpet, while original owner's manual and document wallet are cool to see*

**Contact:**

John Hawkins or  
Ryan Swain  
Specialist Cars of Malton  
York Road Business Park  
Malton  
North Yorkshire YO17 6YB

Tel: +44 (0)1653 697722  
specialistcarsltd.co.uk  
john@specialistcarsltd.co.uk  
ryan@specialistcarsltd.co.uk

*Below: Just the ticket for exploring the Yorkshire byways on one of those balmy summer's evenings we currently dream about...*

He expands on this for several sentences, and I make this point because it's a measure of how the implementation of innovations like fuel-injection, increased engine capacity of a scant though not insignificant 200cc, as well as the lengthened wheelbase, were considered almost quantum leaps at the time, and certainly meriting serious comment.

Anyway, we're up and running, and I'm already revelling in the urgent bark of the 2.0-litre flat-six. Apart from dog-leg 1st, the next thing to acclimatise to is the rest of the shift pattern. The thing about this particular gate is that 3rd and 5th are very close together so it's very easy to go from 2nd into 5th, but that is something you just pay attention to till it becomes second nature.

The E is a lovely drive: it's extremely lively, with plenty of power available, and it must have been quite a thing in 1969.

It loves to rev, and the torque and traction are phenomenal. I'm immediately struck by its delicacy of touch, lightness of feel, and I can sense the delicacy of the steering through the narrowish tyres and the delightful poise around the curves,

notching the lever up and down between 2nd, 3rd and 4th depending on the severity of bends and undulations; it's nimble, with awesome acceleration if revved, accompanied by that glorious metallic flat-six soundtrack.

As for braking, all 911s of this era require firm pressure on the pedal, but they do stop reliably since dual-circuit brakes were adopted for the 1968 model year. And yet, if I'm not trying hard, it's not demanding, a relatively relaxing car to drive, loping along at 3500rpm in top. The corners swing by as the 911 dances elegantly through the tree-lined Yorkshire lanes. It's wonderful fun.

Yes, there's no doubt that it's a juicy little number. As Malton's John Hawkins says, 'This is the most original E we have ever seen, with the interior being 100 per cent original and unrestored.' Just shy of half a century since it was built, that is pretty amazing. It seems to me that despite its condition, rather than be mothballed out of sight, it could still serve as a highdays and holidays car. Better make that fruit salad days... **CP**

**“REVELLING IN THE URGENT BARK OF THE 2.0-LITRE FLAT-SIX...”**







# Porsche Restorations RS911

Body work and restoration, servicing, pre MOT's. Re-creations.



agents for PMO carburetors

t:01686440323 m:07921210593

e:mark@rs911.com w:www.rs911.com



## Electrical Innovation for your Air Cooled 911



### CDI+ Ignition



- Fits 911 '69 - '83 (+ Turbo to '89)
- Dyno proven power increase
- Custom ignition mapping
- 3 rev limiters
- Tacho calibration
- Shift light
- MFI fuel cut off

### Fuse Panels



- Fits 911 '74 - '89
- ATO Blade fuse reliability
- Integrated headlamp relays
- LED fuse blown indicators
- No cutting of wiring loom
- No holes to drill
- Rear panel also available

[www.classicretrofit.com](http://www.classicretrofit.com)

+44(0)1825 830323



**356® & 912®** 80 - 91 mm  
1955-1969



**911®** 80 - 106 mm  
1965-1998



**914® & 912E®** 94-105 mm  
1969-1976

**NICKIES™**  
PERFORMANCE AIR-COOLED CYLINDERS



- Twice the thermal conductivity and more surface area than factory cast aluminum cylinders.
- At least 50% greater tensile and ultimate yield strength than factory aluminum cylinders.
- Stronger and more ductile than any cast cylinder.
- Increased strength and ductility allow for larger bore sizes and larger slip-fit cylinders than previously possible - up to 106 mm.
- Most cylinders come half-mooned for improved crankcase windage, which is typically good for 8-10 HP over non-mooned cylinders.
- Limited lifetime warranty on cylinder plating. Single replacement cylinders available.



STOCK & BIG BORE KITS AVAILABLE  
FOR IMMEDIATE DELIVERY



SCAN THE CODE OR VISIT  
[WWW.GONICKIES.COM](http://WWW.GONICKIES.COM)  
FOR FULL LINE OF  
NICKIES™ CYLINDERS  
AND KITS.



EXCLUSIVE DISTRIBUTOR IN EU:

**CUSTOM CONCEPTS**  
SPECIAL PARTS FOR SPECIAL CARS

CUSTOM CONCEPTS  
Oude Baan 6, NL-4825 BL BREDA, The Netherlands  
Phone / WhatsApp: +31622756519  
[www.custom-concepts.nl](http://www.custom-concepts.nl)

All logos and trademarks were used for product identification purposes only. Porsche® 356®, 911®, 912® and 914® are registered trademarks of Dr. Ing. H.c. F. Porsche



 <p><b>Porsche 911/934 Tribute</b></p> <ul style="list-style-type: none"> <li>• 934 Jagermeister Tribute</li> <li>• Jagermeister Orange Livery</li> <li>• Low Mileage</li> </ul> <p>Call us on 01653 697722 <b>£99,995</b></p>	 <p><b>Porsche 911 2.4T</b></p> <ul style="list-style-type: none"> <li>• In Stock Now</li> <li>• Slate Grey</li> <li>• Full Nut &amp; Bolt Restoration</li> </ul> <p>Call us on 01653 697722 <b>£114,995</b></p>	 <p><b>Porsche 964 Turbo</b></p> <ul style="list-style-type: none"> <li>• In Stock Now</li> <li>• Marine Blue</li> <li>• High Spec</li> </ul> <p>Call us on 01653 697722 <b>£104,995</b></p>
 <p><b>Porsche 911 2.7 RS RHD</b></p> <ul style="list-style-type: none"> <li>• Lightweight</li> <li>• Very Famous Car</li> <li>• Incredible History</li> </ul> <p>Call us on 01653 697722 <b>EPOA</b></p>	 <p><b>Porsche 911E 2.0 RHD</b></p> <ul style="list-style-type: none"> <li>• In Stock Now</li> <li>• Right Hand Drive</li> <li>• Tangerine</li> </ul> <p>Call us on 01653 697722 <b>£149,995</b></p>	 <p><b>Porsche 997 Turbo</b></p> <ul style="list-style-type: none"> <li>• Tiptronic</li> <li>• Midnight Blue</li> <li>• Low Mileage</li> </ul> <p>Call us on 01653 697722 <b>£64,995</b></p>
 <p><b>Porsche 993 Cabriolet</b></p> <ul style="list-style-type: none"> <li>• In Stock Now</li> <li>• Arctic Silver</li> <li>• Low Mileage</li> </ul> <p>Call us on 01653 697722 <b>£54,995</b></p>	 <p><b>Porsche 993 C4S</b></p> <ul style="list-style-type: none"> <li>• In Stock Now</li> <li>• Very Rare Car</li> <li>• Arctic Silver</li> </ul> <p>Call us on 01653 697722 <b>£69,995</b></p>	 <p><b>Porsche 993 C4 Cabriolet</b></p> <ul style="list-style-type: none"> <li>• In Stock Now</li> <li>• Guards Red</li> <li>• Cabriolet</li> </ul> <p>Call us on 01653 697722 <b>£49,995</b></p>
 <p><b>Porsche 964 C4 Cabriolet</b></p> <ul style="list-style-type: none"> <li>• In Stock Now</li> <li>• Basalt Black</li> <li>• Very Low Mileage</li> </ul> <p>Call us on 01653 697722 <b>£59,995</b></p>	 <p><b>Porsche 997 C2S</b></p> <ul style="list-style-type: none"> <li>• In Stock Now</li> <li>• Arctic Silver</li> <li>• Very Low Mileage</li> </ul> <p>Call us on 01653 697722 <b>£34,995</b></p>	 <p><b>Porsche 993 RSR</b></p> <ul style="list-style-type: none"> <li>• In Stock Now</li> <li>• Cup Homage</li> <li>• Signal Orange</li> </ul> <p>Call us on 01653 697722 <b>£89,995</b></p>
 <p><b>Porsche 964 Turbo</b></p> <ul style="list-style-type: none"> <li>• Total Concours Car</li> <li>• GP White</li> <li>• Full Nut &amp; Bolt Restoration</li> </ul> <p>Call us on 01653 697722 <b>£199,995</b></p>	 <p><b>Porsche 928 GTS</b></p> <ul style="list-style-type: none"> <li>• In Stock Now</li> <li>• Amazon Green</li> <li>• Tiptronic</li> </ul> <p>Call us on 01653 697722 <b>£79,995</b></p>	 <p><b>Porsche 911 2.7S</b></p> <ul style="list-style-type: none"> <li>• In Stock Now</li> <li>• Summer Yellow</li> <li>• Very Low Mileage</li> </ul> <p>Call us on 01653 697722 <b>£54,995</b></p>

[WWW.SPECIALISTCARSLTD.CO.UK](http://WWW.SPECIALISTCARSLTD.CO.UK)

## Porsche 911 2.7 RS RHD



Specialist Cars of Malton are proud to present one of the most famous RHD Porsche 911 2.7 RS Lightweights in the world. For more information please call 01653 697722 or email us at [john@specialistcarsltd.co.uk](mailto:john@specialistcarsltd.co.uk)



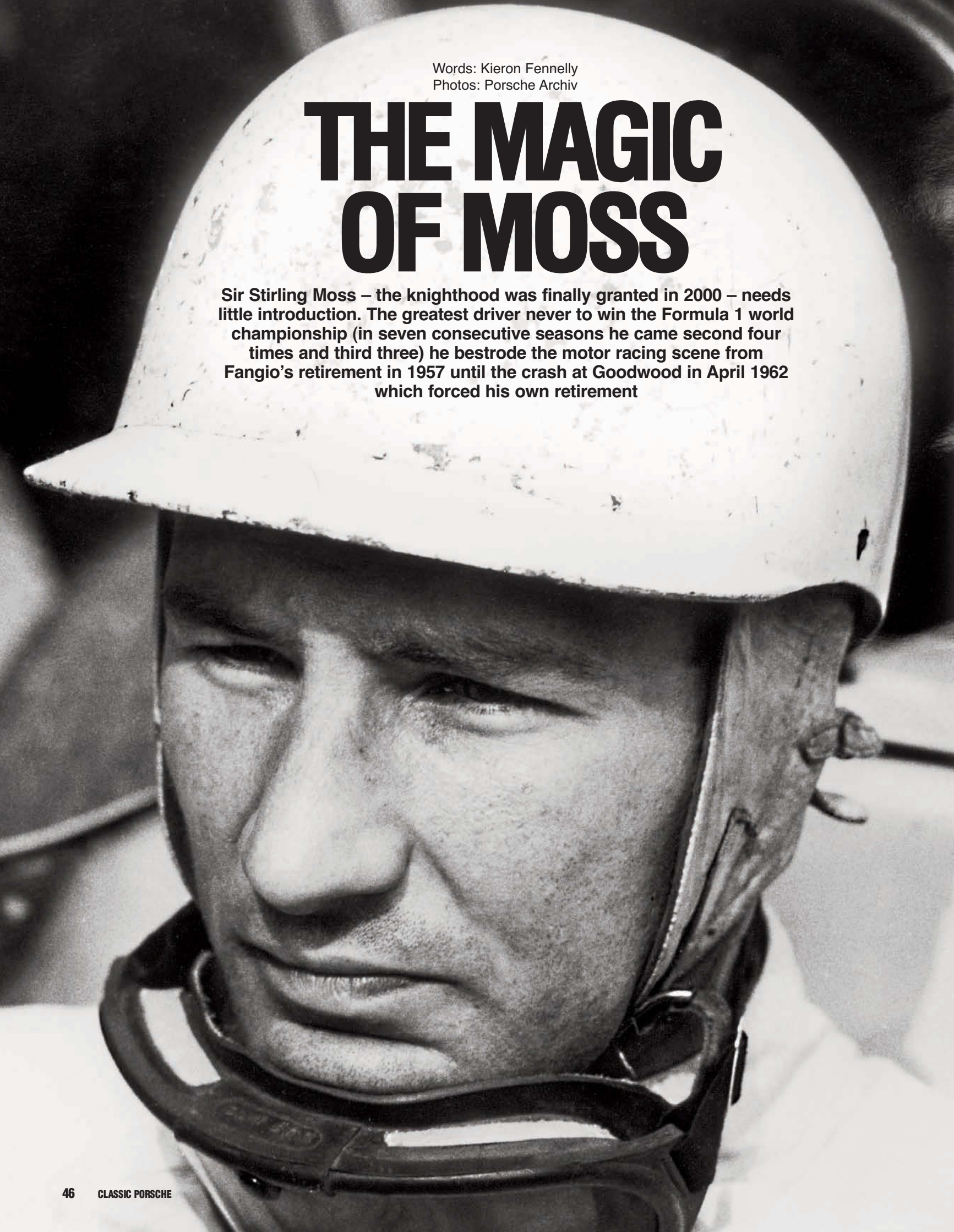

Words: Kieron Fennelly  
Photos: Porsche Archiv

# THE MAGIC OF MOSS

Sir Stirling Moss – the knighthood was finally granted in 2000 – needs little introduction. The greatest driver never to win the Formula 1 world championship (in seven consecutive seasons he came second four times and third three) he bestrode the motor racing scene from Fangio's retirement in 1957 until the crash at Goodwood in April 1962 which forced his own retirement





Above: Moss, his eyes a picture of concentration, awaits the start of the 1960 Syracuse Grand Prix in his Rob Walker-entered Porsche 718/2 Formula 2 car

However, what is much less appreciated is that Moss, usually and correctly associated with makes such as Jaguar, Mercedes, Maserati or Lotus, was also a handy exponent in Porsches. The connection between the former racing driver accoladed on his 80th birthday as 'the greatest living Englishman,' became apparent to later generations only in 2010 when Moss purchased an RS61 for a reported \$1.7million. He explained at the time it was with this car's predecessor that he had come within three minutes of winning the 1961 Targa Florio where, paired with Graham Hill, his works RS60 had run away from Gendebien and von Trips' Ferrari.

Moss acquired this RS 61 with the intention of racing it in historic events, but a crash at Laguna Seca in 2010 badly damaged the car and evidently affected the then 81-year-old Sir Stirling, too. At Le Mans in June 2011, intending to compete in the historic race which these days precedes the 24 hour event, he announced after practicing that he was quitting competition driving altogether.

Stirling Moss has always been one of the most accessible and reported on of racing drivers, but little has been written of the role Porsche played in his career. Indeed the official Moss biography, an enthralling and comprehensively illustrated

account by Robert Edwards has but one picture of Moss in a Porsche, a 550 Spyder, and nothing in the text: all the more reason, then, to hear Moss's version of events.

We have come to London to visit Moss in his London home in the Mayfair street that he has lived in since the early sixties. It's a tall, narrow mews house and his office on the ground floor complete with picture window facing a tiny yard is, incredibly, still exactly as Ken Purdy describes it in his fine biography of Moss, *'All but my Life'*, which was published in 1963. Moss smiles at the recollection:

'Yes, it was quite a book. He (Purdy) just sat where you are now and turned on his tape recorder. In fact he was freelancing and he'd only come to do an interview for *Playboy*, 3000 words or something, but we talked so much, we began to realise we had enough material for a book.'

The outcome of which the *Times* said, with typical period understatement, 'revealed more of the man than any study so far produced,' is generally thought to be one of the talented Purdy's best pieces of writing. Moss speaks with a candour that was quite groundbreaking at the time – the beginning of the swinging sixties, and the two men's conversation is informative, edifying, never banal. It was a style that the more sophisticated late night TV shows would soon adopt.

But Purdy, too, overlooked Moss's Porsche achievements.





Admittedly these are a short chapter in the Briton's 15-year career, but in 12 races for Zuffenhausen he won six outright, took a class win and third overall in the Buenos Aires 1000km, and lost two more potential wins through mechanical mishaps. His success helped to propel Porsche to Formula 1. How did Moss come to race Porsches in the first place? His reply is typically blunt:

'When I was racing, you could always depend on "Kraut" cars. Only Ferrari could compare in terms of reliability. From 1950 I was going on to the Continent with John Heath to race his HWMs and I became aware of Porsches. It was obvious they were reliable because they always seemed to be chalking up class wins. The only drawback was with 1500cc they lacked the top speed of the six-cylinder cars. Porsche was a very young company, too. It couldn't pay anything like the money that, say, Mercedes was offering, which amounted I think to something like a thousand pounds for signing at the start of the season and 90 per cent of winnings. I raced

Porsches when my contract allowed me to.'

He consults a diary from the cabinet behind him: 'I see my first Porsche race was in a works 550 in the 1955 Governor's Cup race at Lisbon. I got pole position, fastest lap and first place!' It was an auspicious debut. The drive had come about through Porsche's racing manager and talent spotter, Huschke von Hanstein, who had done well to sign Moss,

already a household name in Britain and first non American winner at Sebring in the 1954 12 hours.

In his next outing for Stuttgart, the nine hour race at Goodwood in August 1955, Moss again drove a works 550 which this time he shared with von

Hanstein. The diary reads simply 'leading, retired: collision.'

'I honestly can't remember whether it was Huschke or I who crashed (In fact Moss who leading his class slid on oil, colliding with Tony Crook's Cooper Bristol and taking them both out of the race) Huschke still used to race in those days. He was a fair driver, but he was already more involved as the Porsche team manager.'

## "I GOT POLE POSITION, FASTEST LAP AND FIRST PLACE!"

*Above: Moss, standing at the very right of the photograph, on the grid of the 1960 F2 race at Aintree. After a determined showing, Moss finished first overall*





*Above left: Zeltweg, September 1960, Moss leads Marsh in the Lotus 18, followed by Edgar Barth in Porsche 718/2 #2, with Jack Brabham bringing up the rear*

*Above right: Stirling Moss looks pleased about his unexpected class victory with the 356 Carrera GT at the 1961 Nürburgring 1000km. Herbert Linge is on the right next to the winning car*

*Below: In nine F2 outings in the Rob Walker team Porsche, Moss won five races in 1960, stamping his mark on the Formula in an emphatic way*



The motor racing historian Doug Nye has referred to von Hanstein's penetrating, almost intimidating eyes. How did Moss find the baron? 'Oh I can certainly imagine he could be intimidating. He was in the SS wasn't he? I'd have hated to be on the wrong side of him in the war!'

Did von Hanstein have much in common with Alfred Neubauer (Mercedes team manager)? 'No, they were very different. Neubauer had a lot of pressure, the weight of the company on his shoulders. Mercedes had made a huge financial commitment to motor racing. Everything, the whole operation, was planned to the last detail.'

'If you saw Neubauer timing one of his drivers, he wasn't recording the lap, he wanted to know just how quickly the fellow was changing from second to third. Von Hanstein wasn't involved like that at all. He was more an opportunist. He would leave the set up of the car entirely to me. I'd approach him for a drive and he'd say, 'let's give it a go then' and we'd agree a rate.'

'In those days it was traditional to give 10 per cent of winnings to the mechanics and split the rest 50:50 between the driver and the team manager. With Porsche I might get £200 start money, but I used to give Huschke 40 per cent not half because I always reckoned he could make up the rest

doing deals on the side. If there was any other money going, he'd have it – he was like that!'

By 1956, Mercedes had withdrawn from competition and Jaguar would follow at the end of that year. Moss then drove for Maserati and in '57 for the new British team Vanwall in F1, and stayed with Maserati in sports car events. However, at the end of 1957 Maserati, in financial trouble, scaled down its activities before it, too, withdrew from competition altogether. This freed Moss outside European events and von Hanstein paired him with Jean Behra to race in the off season Buenos Aires 1000km.

They won their class and came third overall with the 1588cc RSK. Moss had co-driven with the Frenchman at Maserati and has a high opinion of him: 'Jean was tough – a fine driver. He never gave up.' Behra would go on to build his own Porsche, the Behra Porsche, with help from Alessandro de Tomaso. Alas a promising venture never took off as Behra, probably trying too hard, died on the infamous banking at Avus in the F2 support race prior to the 1959 German GP.

Porsche was by now a significant force and with 3rd, 4th and 5th at the 1958 Le Mans 24 hours, was really beginning to show its mettle, but without Stirling Moss, contracted that year, though unsuccessfully as it turned







out, to Aston Martin for the French race.

Driving largely for Cooper and Aston Martin again in 1959, Moss did no competitions in Porsches, but an important development occurred that year which would bring him and Zuffenhausen together again the following season. The organisers of the F1 world championship announced that with effect from 1961 F1 would move from 2.5- to 1.5-litres. Characteristically, von Hanstein had already seen the possibility of another outlet for Porsche's racing aspirations when the 1500cc F2 category was introduced in 1957.

He had a couple of 550 RSs and 718s rebuilt to central seat configuration whilst retaining their enclosed sports car

bodywork. Wins in the F2 section of the German GP and the F2 support race at the 1958 French GP were enough to persuade Ferry Porsche to give the green light for low key development of an F2 single-seater for 1959 with a view to entering F1 in 1961 when it too changed to 1500cc.

Rising German star Wolfgang von Trips, also von Hanstein's protégé, crashed the new car in the scramble at

the start of the Monaco Grand Prix, but scored a fourth a few weeks later at Brands Hatch. At Porsche's request Moss test drove the F2 Porsche at Goodwood and lapped faster than his best time there with his Cooper that season.

After the withdrawal of Vanwall following the 1958 season, Moss had abandoned factory teams and driven Coopers for his friend Rob Walker. As usually happens with private teams, Walker and Moss had to make do with the previous season's

technology. So when von Hanstein offered the British équipe a works supported F2 Porsche for the 1960 season, they jumped at the chance.

'There was no interference: Porsche provided the car and the mechanics and left us to get on with it,' recalls Moss.

1960 was the transitional year from the 2.5 to the 1.5 formula and teams took

every opportunity to try out their new 1500cc cars. Moss would not let Stuttgart down: in nine F2 outings in the Rob Walker team Porsche, Moss won five races, retired while leading and setting fastest lap at Syracuse, scored a second place at Goodwood and in his two minor placings, 4th and 11th, he was slowed by mechanical maladies. It was little short of sensational.

*Above: Cape Town, South Africa, 1960, Stirling Moss with his traditional #7 race number, crosses the line ahead of Porsche team mate Jo Bonnier*

## “PORSCHE PROVIDED THE CAR AND LEFT US TO GET ON WITH IT”





*Above left: The age of the voluminous raincoat... Moss shares a few moments with Jo Bonnier ahead of the 1960 Belgian Grand Prix*

*Above right: Buenos Aires 1000km in 1958 marked the last time the factory raced the 550A Spyder*

*Below: Stirling Moss and Graham Hill shared the driving in this 718 RS 60 at the 1961 Nürburgring 1000km. Engine problems led to an early retirement*



At the new Österreichring at Zeltweg, for example, the works Porsches finished one, two and three, Moss sportingly not increasing his lead over Hans Herrmann in the second Zuffenhausen entry to more than a second or so when he could have romped away; Edgar Barth's Porsche brought up the rear some distance behind.

The Austrian crowd burst on to the track in the last couple of laps, such was its excitement at this first demonstration of a total Porsche domination which was to become the norm ten years later. No doubt having the world's leading driver had spurred Porsche to put more into their F2 effort than they otherwise might have.

But Moss, ever the patriot, returned to a British mount for 1961, this time a Lotus, still under Rob Walker's colours. His one Porsche excursion that year was the Mille Miglia in a works RS 60.

'The Porsche (by then 1966cc) was an unusual car for me to be driving in a sports car event because you always had this problem of lack of high top speed, otherwise it was brilliant – brakes, handling and like all German cars, properly put together,' recalls Moss.

He and Graham Hill all but pulled off another Porsche giant-killing act: in his typically thorough way, Moss had spent time in a road car beforehand lapping the twisting 73km Sicilian circuit until he felt he knew every bend. In an eventful race, the duo had the lead, then lost it during Hill's stint, now Moss driving the final stretch had built up a commanding advantage over four time Le Mans winner Olivier Gendebien's Ferrari, several minutes behind him in second place. 'Then the differential gave out! The cornering forces had stretched the axle bolts and the oil drained out just before the end!'

It was to be the Briton's last appearance in a Porsche and his last full motor racing season. Was there ever a possibility that for 1962, Porsche might have offered Rob Walker an 804, Porsche's flat-eight F1 entry? Dan Gurney would drive it to wins at Solitude and Rouen, backed by Jo Bonnier, but with Moss as well, what might Stuttgart have achieved? We could speculate for ever, but as it turned out, Moss was off to Modena, or so he planned...

'There was no thought of going with Porsche: we had already done a deal with Ferrari for '62. Ferrari would build an F1 which I would drive under Rob Walker's dark blue colours.'







The deal with *il Commendatore* was nothing if not a surprise: Moss had fallen out with the irascible Enzo Ferrari in 1952, humiliated and frustrated by the Italian's casual high handedness. As a result, Ferrari was the one major player for whom he had never driven.

But Ferrari had lost its number one driver von Trips in the terrible accident at Monza the previous season. Moss was clearly the best driver available and lacked only a top flight car. Hence the rapprochement, the outcome of which was the agreement to prepare a car for the Rob Walker team to campaign. 'Of course, I never did drive the Ferrari because the accident intervened before the GP season got underway.'

Moss was out of commission effectively for almost a year after the Goodwood crash, discovering that brain injuries took much longer to heal than broken bones. In May 1963 he

decided after a private test session at Goodwood with a Lotus 19 that his reaction times were no longer fast enough for top level motor racing and he announced his retirement.

However, racing was his life and as much as anything to keep a foot in the sport, in the spring of that year he established his SMART team (Stirling Moss Automobile Racing Team). It entered cars such as Lotus Elans and Brabham BT8s in sports car events and led in February 1964 to the first, and until 2010, the only Porsche Stirling Moss had ever possessed. He bought a 904, chassis number 904 025, and the first 904 of the six that were imported to the UK.

'In my entire career I'd never owned a Porsche. Initially I drove my father's BMW 328. When I was with Mercedes Benz, they gave me and Fangio 220S company cars; later I owned a Facel Vega and, of course, I had Mini Coopers.' At

*Above: Moss drove a wide variety of Porsches during his relatively short career with the German marque, including the 718/2 F2 car, Carrera Abarth and RS 60*

*Below left: 1958, Syracuse and the last outing in the 550A Spyder*

*Below right: Deep in thought at the start of the 1960 Syracuse Grand Prix*







## The best tyres for vintage, historic and classic cars

Produced by a Porsche owner (with a degree in Engineering) who was not impressed with the tyres available, the Blockley 165VR15 is the only V-rated tyre available in this size. Featuring twin-steel-belted construction, it also has the perfect period-correct look, as is our 185/70VR15 size.

The Blockley 165VR15 has been used to win the gruelling Pirelli Challenge, an event largely contested by vehicles using competition tyres, which are far from ideal for road use.



### So, this is the Blockley Challenge...

We are offering readers of Classic Porsche a discount. The 165VR15 has been reduced in price from £119 to £99, plus a further discount making a set of 4 tyres £356, an easy number to remember! So you can try them for yourself on your own Porsche. And if for any reason you are not seriously impressed with them, even after a thousand miles or so, we will offer you a full refund.

Blockley tyres are produced to the highest quality on new equipment, using steel moulds in the traditional manner, a process which calls for the use of a mould release agent. This requires the tyres to be scrubbed-in prior to spirited use.



### The Blockley Tyre Company Ltd

[www.blockleytyre.com](http://www.blockleytyre.com)

Tel: 01386 701 717 Email: [info@blockleytyre.com](mailto:info@blockleytyre.com)

\*The Blockley 185/70VR15 tyre is also similarly available at 10% discount.  
(Offer limited to 100 sets)





*Above: Moss led the 1960 Syracuse GP for 26 laps before his engine let go, allowing von Trips in his Ferrari to take one of the last ever victories by a front-engined GP car*

the time of their meetings in 1963, Ken Purdy talked of being whisked around at high speed by Moss in his Lotus Elite.

'I chose a Porsche for competition because I knew it would be reliable. I never intended to drive it myself: Hugh Dibley (BOAC 707 pilot, amateur racer and first man to lap Goodwood at over 160kph) and Innes Ireland raced it, and David Hobbs and Lloyd Casner came ninth in the 1000km at the Nürburgring.'

The 904 was also entered for the Le Mans 24 hours, but difficulties with the French organisers meant the Porsche did not start in the race itself. 'After that, we didn't race it again and Valerie (Pirie) used it in a couple of rallies; later we sold it.' The 904, which returned to Germany in the early 1970s, re-emerged in 2011 after being returned sympathetically to its original condition.

So why, almost fifty years later, did Moss buy another Porsche? After all, he was already competing in historic events with his 1600cc Osca.

'I heard the RS 61 had come up for sale and I thought it would be the best car I could possibly buy. It's already proved a good investment – people have been offering me more than I paid for it – and it's also a fantastic car: light, agile, just great to drive.'

But in the end he frightened himself and decided not to compete in it after all: 'I've always said that I'd give up when racing was no longer fun. At Le Mans I could see that I would not be quick enough without concentrating harder than I wanted to. Then the fun has gone. It's time to stop.'

At almost 82, it seemed a rational decision. Moss continued to drive his RS 61 at exhibition events for a year or two and the Porsche carried on its racing career, but in other, younger, hands. Until its sale in 2014, it was displayed at the Porsche Experience at Silverstone, which says Moss saved him the problem of where to keep it.

That RS 61 is a fitting reminder that amongst his legion of achievements, Britain's greatest racing driver also played no small part in putting Porsche on the motor racing map. **CP**

## “AT LE MANS I COULD SEE I WOULD NOT BE QUICK ENOUGH...”

At almost 82, it seemed a rational decision. Moss continued to drive his RS 61 at exhibition events for a year or two and the Porsche carried on its racing career, but in other, younger, hands. Until its sale in 2014, it was displayed at the Porsche Experience at Silverstone, which says Moss saved him the problem of where to keep it.

*Below left: How times have changed – lack of Armco barriers and crowd protection paints a picture of different times. Moss at the Nürburgring, 1960*

*Below right: Moss at the wet Belgian Grand Prix, Brussels, in 1960*





# Complete Suspension Packages

Build yours at [ElephantRacing.com](http://ElephantRacing.com) 3 clicks... Done!



[Home](#) | [About](#) | [Contact](#) | [Careers](#) | [News](#) | [Tech Topics](#) | [Shopping Cart](#)

Advanced Suspension Systems For Porsche Cars  
Design & Development



Sales & Support  
+1.408.297.2789

911 ▾ 964 ▾ 993 ▾ 996/997 ▾ 991 ▾ Boxster/Cayman ▾ 914 ▾ 944 ▾ 356 ▾ Merchandise ▾ Search ▾

## Suspension Builder

ONLINE TOOLS

[Suspension Navigator](#)  
[Suspension Builder](#)

### 1 Select Year & Model

Year

Model

996/997/986/987

991

993

914

964

944

### 2 Select Your Package

Street Performance 2

### 3 Review & Approve

Add, update, or remove parts  
using the tables below

**Add To Cart**

#### Front



#### Rear



PACKAGE CHARACTERISTICS +

RIDE COMFORT

41

PERFORMANCE

63

+1 408.297.2789  
[ElephantRacing.com](http://ElephantRacing.com)  
Santa Clara, California, USA  
Fast Worldwide Shipping

**ELEPHANT**  
RACING





Words: Johnny Tipler Photos: Porsche Archiv

# DANCING ON ICE

It's 50 years since Vic Elford and David Stone (bottom right) won the hallowed Monte Carlo Rally, and by way of celebration, they take us on a trip down memory lane...

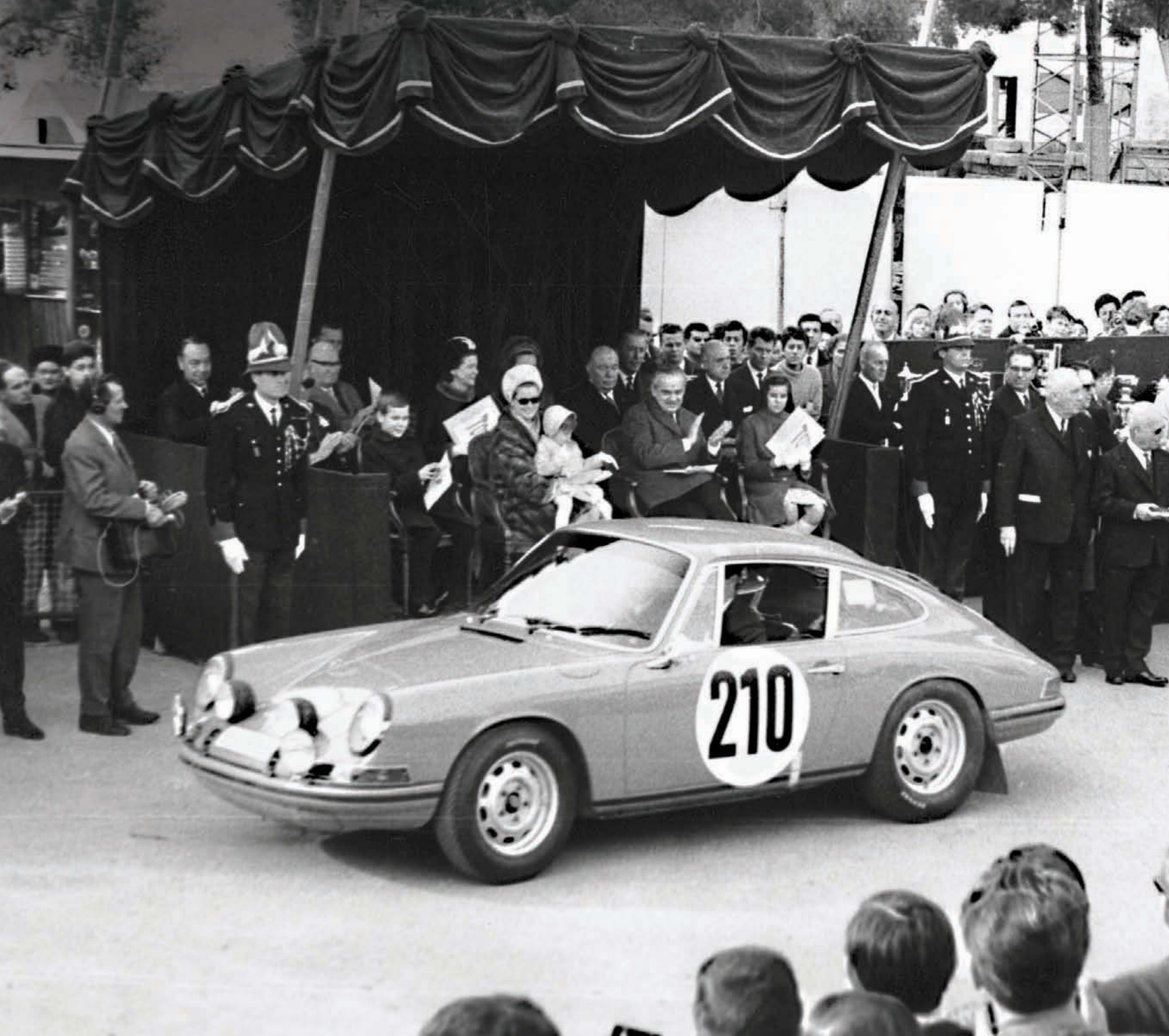





‘It took me five minutes to light a cigarette, I was shaking so much,’ laughs Vic Elford, reminded of the aftermath of his and David Stone’s victory in the 1968 Monte Carlo Rally aboard their tangerine orange 911. It had been a grueling event – no change there – but Quick Vic, keen to amend for his impetuous last-stage crash-out during the ‘67 event when victory was in sight, a year on had needed David’s calming influence ahead of the final night’s showdown. Travelling at 120mph on snow and ice tends to concentrate the mind, as well as the physical skills set.

Vic and David joined forces as budding rally stars in 1963 for the Dutch Tulip Rally in a Triumph TR4, placing third behind two factory Austin-Healeys. They were paired again for that year’s Alpine Rally in southern France in a TR4, exiting dramatically down a ravine, happily without injury. The navigator co-driver is the unsung hero to an extent: the driver tends to win the glory, though actually much of Vic’s glowing reputation is bound up with late 1960s Porsche prototypes, such as the 907, 908 and 917.

Notwithstanding, David Stone (seen below) always took his role extremely seriously, having previously navigated for Pat Moss-Carlsson (Stirling’s sister) and 1959 WRC champion Eric Carlsson himself. He uses a horse racing analogy: ‘The driver is the horse; the navigator is the jockey. The horse is the driving force, and the jockey provides direction, control, pacing and caution.’

In 1964, Vic and David were snapped up by the works Ford team and handed a Cortina. ‘I was a competent driver myself,’ says David, ‘and Vic knew that. But I had decided I would rather be the best navigator than just another driver. At the beginning of the 1964 Monte Carlo Rally in the Cortina, though, I drove all Saturday night, then all day and night Sunday.’

Then, as now, the Monte Carlo Rally – or at least the Historique reprise – began from various departure points across Europe, including Glasgow, Barcelona, Turin, Oslo and Warsaw. The route consisted of thousands of kilometres of tight, twisting two-lane road, lasting a day-and-a-half, and known as time-and-distance sections covered at a precisely controlled average speed. That meant they didn’t require the full-on, opposite-lock challenge needed in the full-speed special stages on the agenda later on.

Nonetheless, driving the never-ending winding secondary roads towards Monte Carlo at an average of 60kph (38mph) for 36 hours straight, negotiating regular traffic, and still be







fresh for the special stages towards the finish was a big ask. David Stone saw it as his role to drive as many of these time-and-distance sections as possible himself, enabling his driver to relax, and then when they arrived at a special stage, Vic would be in good shape.

As well as the 'tulips' – the succession of hieroglyphic diagrams in the route book – communication between them when helmeted was via intercom: 'We had intercoms, very good ones,' says Vic, and our system of pace-notes was a shorthand system which we'd developed over the years, and they were absolutely foolproof.' Were David's navigational skills infallible? 'You mean, did we ever lose out because he made a mistake?' asks Vic. 'Absolutely not! Never ever did he make a single mistake. The only other infallible navigator I know of is Christian Geistdörfer, who was Walter Röhrf's co-driver.'

Relations with Ford began to pall, and in November 1966 Vic contacted Porsche.

Rallying was nothing new to Zuffenhausen: a works 911 (and a 904) ran in the Monte in 1965 (Linge/Falk), and in '66 (Klass/Wütherich and Schlessler/Buchet), and competitions director Ferdinand Piëch got the green light for '67 to take the marque into racing and rallying, aiming for the big time. The rallying aspect was pretty much down to Vic and David, though.

'I talked Huschke (racing manager von Hanstein) into lending me a car to go to Corsica at the end of '66, but he said, "You've got a car, that's it, no help, no money", so it all came out of my pocket in Corsica, and we finished third, up against the Alpines and R8 Gordinis, and that changed the whole atmosphere in Stuttgart.'

Vic and David deployed their own system of cryptic hieroglyphics that described every kind of turn, surface and threat along the route, which David relayed to Vic for the

duration of the racing-speed special stages, all the while logging their elapsed time on the Heuer chronograph wristwatch. The factory immediately allocated a 911S for them to use in January's 1967 Monte Carlo Rally. 'They'd said we could tackle the season on a rally-by-rally basis, and I was so convinced about the car I said, "Yes, of course," and we did a big reconnaissance.

'Back in those days, the organisers used to come up with strange regulations year-after-year to try and ensure a French car won. There was one year where the only car that could possibly win was a Dyna-Panhard, and all the privateer owners in France were buying them, and I think there were 58 Dyna-Panhard's in the rally that year!'

Sure enough, in 1967 they came up with a new regulation where the Touring cars were allowed just two sets of tyres, one set on the car and the other set to be carried in the car. 'The first 36-hour session took us back down to Monte Carlo, where we were allowed two more sets, but again, one set for the car and the other set inside the car. The mechanics figured out how to put two wheels and tyres in the car behind our seats and the other two – believe it or not – under the front hood! How they

got them in there I don't know, but they did!'

They led the 1967 Monte almost to the end, placing third when unexpected snow caught them out on inappropriate tyres. Vic recounts the consequence of the tyre restrictions: 'Once we got to Monte Carlo we were leading pretty comfortably, and then for the last night's 600km up in the mountains above Monte Carlo we were allowed another two sets of wheels and tyres. We simply increased our lead, and it got better and better.

'But then, as we left the start line to go over the Turini for the very last time, it started to snow, and I had no snow tyres.

*Above left: Together, Elford and Stone made an impressive team. Stone regarded himself as the 'jockey', while Elford, as driver, was the racehorse which needed his control. Driving near flat-out at night on snow and ice focused the attention, the 'thrill of the chase' showing on Elford's grinning face*

*Above: These days, Elford looks back with affection to the days when Porsches were a major force in world rallying, although he often felt that the Monte's organisers bent the rules to favour French cars...*

*Right: To the victor, the spoils. Smartly turned out for the prize presentation with Princess Grace and Prince Rainier of Monaco*

## “NEVER, EVER DID HE MAKE A SINGLE MISTAKE!”









If I'd had them, they would have been on the car, but as it was, Munari in the Lancia and Aaltonen in a Mini overtook us, because with front-wheel drive they could pretty well go anywhere whatever tyres they'd got on, whereas the Porsche had to have the right tyres, otherwise it became almost un-driveable. So that dropped us back to third.'

Later in the year they won the Geneva Rally, and claimed the 1967 European Rally Championship in their first full season. But just as winning Le Mans far outweighs other related WEC events, a rally team has not truly succeeded until it wins the Monte Carlo. So, for 1968, with Vic and David now entered in the Touring class in a 911T, Porsche prospects seemed promising.

As soon as Porsche gave Vic a 911 to play with he started honing it to his needs, beginning with the gearbox.

'We had a lot in our favour, because pretty well everybody else only had four-speed transmissions whereas we already had five-speeds in the 911. There was already a load of different homologated ratios available for that 'box, so I could literally build the gearbox I wanted for each rally.'

After the '67 Monte Carlo I started working with a man named Herman Bream, who until that moment had been in charge of the customer service department, and then suddenly found himself building rally cars. He was a great engineer, and we got on very well together, and I told him what was coming up and what I thought I would need, and we designed my own gearbox.' The relationship worked, enabling Vic to win where 165mph top speeds were necessary on circuit stages, as well as mountain stages where 100mph was sufficient.

And so to Monte Carlo 1968. The 911 danced to Vic's tune. 'I always worked with a short-wheelbase car, which was just marvellous: it would turn on a dime, it was a fabulous car in the mountains, and so when for 1968 the Monte Carlo organisers came up with their new regulations – and for the first time in the history of the event it became a scratch event: quite simply, the fastest guy in the fastest car is going

to win, and I said, "Well, that's going to be us," because by then I'd developed the 911 into easily the fastest car around the mountains.'

Having started from Warsaw and made it down to Monaco, they didn't have any scouts to report on road conditions and the weather. 'We did our own recce, and we'd been out on the Wednesday night so we knew where all the ice and snow was to re-draft our pace-notes, but we still had to come up with our tyre selection 12 hours before the action.'

'All the weather forecasts throughout the Alpes Maritimes said it was getting warmer, and there was no way it could get any worse, so I went with two sets of lightly studded M&S all-weather tyres, and not heavy snow tyres. The only problem was when we set off on the last night I was all tense and

really uptight because of the year before when we should have won.

'So, David calmed me down, and he said, "Look Vic, we know there might be less snow than last night, but there certainly isn't going to be more, and you know you're the quickest in the mountains, so forget about the snow." We knew there were a few patches, but I chose to go on racing tyres anyway, and on

the way up to Turini it was very tight and twisty, and on the way down the other side we were up to about 120mph – on racing tyres going over snow and ice again! We managed to keep it altogether, and when we got to the bottom we'd taken almost a minute off Gérard Larrousse on a 17-minute, 26km stage, and that was what won the event for us.'

David recalls the crucial 24km stage between Beuil and St Sauveur-sur-Tinée. 'I helped Vic collect himself and calm down before the start. We had no guarantee that the ice on the route hadn't changed dramatically, and we took the start, Vic fiercely determined to regain the lead from Larrousse.'

'With ice and snow everywhere, the Porsche was on the ragged edge and, even so, with the close-ratio 'box, in many places it was hitting the rev-limiter in top gear, getting wheel-spin at 120mph over black ice – in the mountains at 4.00am!

**“WE WERE UP TO ABOUT 120MPH ON RACING TYRES OVER SNOW...”**

*Above: 'Dancing on ice' perfectly sums up the way that Elford controlled the 911 on the Monte Carlo's frozen roads. Regulations changed in 1968, turning the event into something of a mad dash for the finish: 'The fastest guy in the fastest car is going to win', recalls Elford. It was quite a feat...*

*Right: Calm before the storm as Elford applies the rally decals to the 911T. Note the rubber deck lid tie-downs and the twin-pipe sports exhaust system. Elford had the car's gearboxes built to his specification*







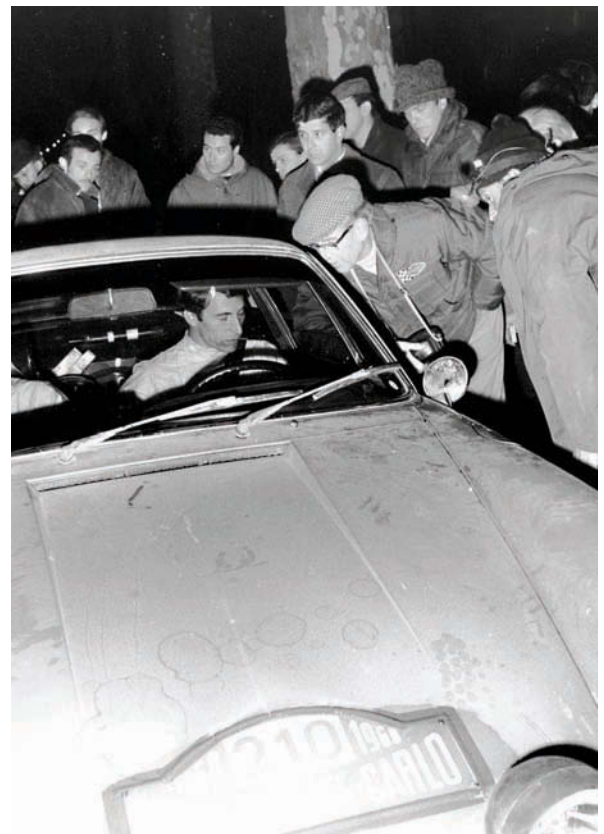

At the stage finish in St. Sauveur, no-one believed the 911 could've gone as fast as the timers said we did; "There must've been a mistake," people said. "Elford has streaked from 15 seconds behind Larrousse to 45 seconds ahead."

'Impossible as it seemed, the 911 had made up an entire minute! It was very dodgy. Afterwards, Vic was shaking: it was five minutes before he could light a cigarette. For my part, I thought, "We're not paid enough to do this!"' Indeed, as a measure of the rally's punishing nature, in '68 there were 79 classified finishers and 123 retirements.

Meanwhile, in a desperate effort to regain the lead for Alpine-Renault, Larrousse had crashed out. Porsche went on to achieve the pinnacle – overall victory in the 1968 Monte Carlo Rally. Another 911T of Finns Pauli Toivonen and Martti Tiukannen came 2nd, with three BMC Mini Coopers 3rd, 4th and 5th. Vic Elford, David Stone and Porsche had proved a point: the 911 was a great rally car, and could win the most arduous event on the calendar.

Then as now, the post-rally celebration dinner was in the Sporting Club, and it was always a black-tie event. 'It was always a great evening,' remembers Vic, 'and one or other member of the Monegasque Royal family was always there to present the trophies. In '68, actually, we had the main prize-giving in the daytime up in front of the castle, with Princess Grace and Prince Rainier giving us the trophies, and little Stephanie peering from behind mum's coat because she was a bit shy at things like that.

'And then in the evening there was the dinner party in the Sporting Club, and I was obliged to make a speech, and at the time I didn't speak French a lot, like I do now, but everybody had said, "You've got to make a performance out of it," so I simply got up onto the stage and took the microphone and said, "I'm very sorry to tell you, I don't know how to sing..." and that brought the house down!

'There was nothing more than that, and then literally the next morning I was on a plane to Daytona for the 24-Hours! That's the race where the trio of 907s came 1st, 2nd and 3rd, crossing the line in a staged dead-heat finish, marking Porsche's first victory in a 24-hour race – and

Vic was driving the lead car.

The last two rallies of 1968 didn't go to plan, however. The 911S's oil filter came adrift on the Corsican Rally, which David believes was an act of deliberate subterfuge in *parc fermé*, because it wasn't the kind of mistake a Porsche mechanic would ever make. Then, a fortnight later on La Rallye Ronde Cévenole, Vic and David were leading when their 911's differential broke.

The duo's last rally for Porsche was the 1969 Monte Carlo, aiming for a repeat victory and, indeed, they had the lead late in the event, with Björn Waldegård and Lars Helmér running second in another 911S (they'd come 10th in '68). A couple of hours from the finish, Waldegård lost his brakes and dropped back three minutes, but instead of backing off accordingly, Vic pressed on, only to prang the 911 into a tree. Emerging

unscathed was scant consolation for a lost victory – which instead went to the Swedish pair, who also won it in '70.

After that, Vic devoted himself to long-distance endurance circuit racing, and was a key player in Porsche's annexing of the WSC for the next three years. David's last rally was the 1971 Monte Carlo, which he and driver Ove

Andersson won in an Alpine-Renault A110, his tenth win in 34 international events.

Vic and David's Monte victory in '68 demonstrated that the 911 could win the big-time rally as well as perform on track – Karl von Wendt had just won the '67 European Touring car title (Division 3). Ten years ago, we followed them on the 2010 Monte Carlo Rallye Historique, as they reprised their '68 win in another orange 911T.

Chauffeur their respective partners Anita and Bebe in a Cayenne from stage to stage, we invariably showed up at some remote location like the Col de l'Escharasson ahead of schedule to snap them in action, just in time to see an orange 911 flash past. The Historique event is regularity-based, but Vic and David spurned the rules and went flat out, just like '68. Now I remind Vic of this: 'We've no time for regularities!' He's joking, right? I don't think so. These guys are a special breed. **CP**

*Above left: Elford was a master at exploiting the SWB 911's handling to the full, throwing it around the Alpine hairpins with aplomb. The Porsche proved itself to be a formidable rally weapon, a fact that is often overshadowed today when so many 911s are used for historic circuit racing*

*Above: Spattered with dirt, the 911T checks in at a time control. Elford and Stone finished first overall in 1968, with Pauli Toivonen and Marti Tiukannen second in another 911. A last minute accident wrecked the pair's chance of a repeat victory the following year*

**“I THOUGHT,  
WE’RE NOT PAID  
ENOUGH TO DO  
THIS!”**



New parts for your Porsche.  
Only for your Porsche.

# ROSEPASSION.com

**Even  
more parts...**

for your 356 911 912  
914 924 928 930 944  
964 965 968 986 987  
993 996 997 boxster  
cayman or cayenne

Order our catalog on the website :  
PIÈCES 911 et PIÈCES SPORT

**NEW  
WEBSITE**

The screenshot shows the ROSE PASSION website interface. At the top, there's a search bar with options for 'Search by keyword' and 'Entry by reference'. Below that, it says 'All the parts for all the vehicles!' and lists various Porsche models. There are three images showing car parts: a wheel, a rearview mirror, and a headlight. Below the images is a 'SELECT YOUR VEHICLE' section with a carousel of car models (996, 996 GT3, 996 Turbo, 997 / 05-08, 997 / 05-11) and a filter for '2005', '997 C2S', 'COUPE', and 'MANUAL GEARBOX, 6'. At the bottom, there are 'OUR GUARANTEES' including 'Delivery anywhere in Europe and the French overseas departments and territories', '100% secure', 'Tracking parcels via Chronopost International', and 'Payment by Bank card / Cheque / Bank transfer'.

**ROSE** PASSION offers new parts for any Porsche models  
from 1950 via mailorder. For a simple and fast order, select it  
directly on our website: [www.rosepassion.com](http://www.rosepassion.com)



Phone : **00.333.82.468.911** - Fax 00.333.82.468.930

Mail : [contact@rosepassion.fr](mailto:contact@rosepassion.fr)

ROSE PASSION - BP 70095 - 54803 JARNY CEDEX - FRANCE





# RGRUPPE EXPERIENCE

A few weeks before Christmas, rumours surfaced about a European TV crew visiting LA, to film a segment about the R Gruppe at the Porsche Experience Center (PEC). *Classic Porsche* witnessed the action – the perfect opportunity to peek at the state of the new art 50,000 square-foot building!

Words & photos Stephan Szantai



Left and below left: No 911 is alike in the R Gruppe – members express themselves through their vehicles

Top right: Jon Dilger's race-ready black 911S coupé will be the subject of a forthcoming feature in *Classic Porsche*

Middle right: To duck or not to duck, that is the question. Hard to win that argument either way you look at it!



Bottom right: You don't see so many modified Targas in Europe, but in the USA it's a different matter. Wide-arched styling looks cool on this long-hood example



Far left: And... Action! Ray Crawford (black shirt) gave pertinent details about the R Gruppe to the TV host

Left: *Classic Porsche* featured Stephane Medam's potent Slate Grey 3.2-litre 911 back in March 2014





**B**ack in November 2016, Porsche generated some positive buzz thanks to its new Experience Center located in Los Angeles, an inspiring destination for the brand's enthusiasts/drivers. It came to be 18 months after the successful opening of a first US-located facility revolving around the same concept, on the opposite side of the country in Atlanta, Georgia. For one reason or another, we never managed to bring our camera gear to LA's venue, until the latter part of 2017.

In a way, we killed two birds with one stone when an outing from the famous R Gruppe involved the said Porsche Experience Center. Word got out that a TV crew was in town to shoot the sport purpose-oriented team, with most of the filming taking place at the PEC. R Gruppe at the PEC on the same day... It seemed intriguing – we had to be there.

The recording was part of 'Turbo', a long-running French weekly TV show with a car theme, which first aired in 1987. Yeah, most of you will miss it; but by the time you read this, you should be able to find it online. (See [turbo.fr](http://turbo.fr), then click on 'Emission').

Many *Classic Porsche* readers will be familiar with the R Gruppe, a highly-influential crew in the Porsche sphere, which gathers like-minded motorheads with a penchant for pre-1974 hot-rodded 911s. We won't dwell on the subject, as we hope to bring to you this year a piece focusing on the

**“WORD GOT OUT THAT A TV CREW WAS IN TOWN TO SHOOT THE SPORT PURPOSE-ORIENTED TEAM”**

group's history that started in 1999, thanks to the efforts of Cris Huergas and Freeman Thomas.

Last fall, the staff of 'Turbo' contacted Ray Crawford, who administers the R Gruppe's So-Cal chapter, to see if he could round up some of his troupe. Filming was to take place on a Tuesday morning, not the best time to invite folks; but over 15 members committed to the happening, a commendable tally considering the short lead time. 'We might have gathered 50 cars, if the event had been organised on a weekend', added Ray.

Vehicles were lined up in an arch in front of the PEC, which gave us the opportunity to look at a very unique mix of 911s. Keep in mind that 'factory-correctness' isn't the name of the game within the group, as members each like to express themselves through their cars – these guys don't play by anybody else's rules. After Turbo's crew was done with the interviews and filming, participants hopped in their 911s and hit the 405 Freeway for a 45-minute commute, to visit Don Murray's private collection. Regular readers will remember we featured his Porsche-oriented shrine a few years ago – see the Winter 2011 issue.





Far left: Another view of that tough Targa. Looks cool...

Left: Rare American Racing mags look excellent on Jerry Murray's SWB 911 coupé



Top right: Welcome to the Porsche Experience Center... If you're in L.A., don't miss it!

Below right: Model gives a good idea of the PEC's impressive layout, next to LA's 405 Freeway

Below far right: Hey, that's Sally Carrera from the movie 'Cars'! Note the altered bumper and roof in particular

Right: American Le Mans' Porsche 911 GT1 Evo looks as good today as when designed in the 1990s



Left: Kelly Mahler-Tribolet (that's her '69-based RS clone) was part of the contingent of lady drivers in attendance

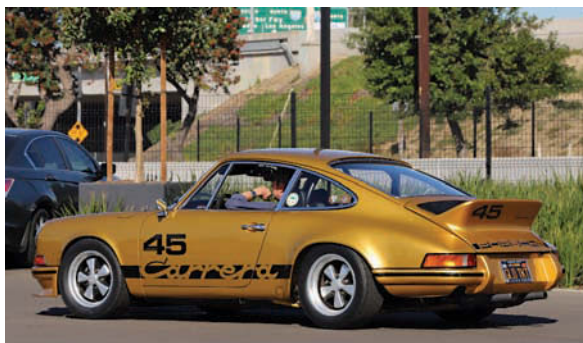

Far left: Representing the S-Registry: Here is club President John Dilger and his '71 911S once again

Right: Yes, the Porsche Experience Center displays newer rides, too – here's the the 911 Hybrid that finished second at the 2015 Le Mans 24 Hours





In the meantime, we stayed at the PEC to find out more about it. What a fantastic experience! The venue covers 53 acres/21 hectares and encompasses four miles of tracks, separated into a half-dozen zones with specific themes: Acceleration Straight, Off-Road Course, Handling Circuit (set as a challenging country road), Kick Plate (a computer-controlled hydraulic plate induces the loss of rear wheel traction), Ice Hill (7 per cent grade with water jets), etc. Perfect ways to enjoy the thrill of driving Porsche sports cars, eh?

Depending on their budget and needs, visitors can get a taste of the facility thanks to various sessions, typically lasting 90 minutes under the scrutiny of a Porsche Drive Coach. Patrons can choose from over 20 models fresh out of the showroom floor, while other options include tests with a particular focus, such as 'G-Force' or 'Mid vs Rear Engine'.

To be clear, the PEC remains open to the public from Tuesday until Saturday (7:00am to 5:00pm); in fact, we highly recommend a visit if you happen to be in Los Angeles. The showroom always features interesting vehicles, most following the 'Classic Porsche' theme. During our tour, the selection included a 1977 935 driven by Jacky Ickx, a 917/30 made famous by Mark Donohue, a 1988 Porsche-March 88P



## “THE 50,000sq FT BUILDING HOUSES THE NEW HOME OF PORSCHE MOTORSPORT NORTH AMERICA”



entered in CART competition, along with newer automobiles such as a mental GT2 RS.

The same 50,000 square-foot building houses the new home of Porsche Motorsport North America. While off-limits to the public, visitors can still admire the workshop through floor-to-ceiling windows. The selection of cars being pampered will leave many weak at the knees... How about a 959 from the 1985 Paris–Dakar rally or a 1972 911 ST raced by the Kremer-Porsche team?

A retail store allows guests to purchase their favourite goodies – we were especially impressed with the insanely detailed \$14,690 919 Hybrid scale model! Upstairs, the 917 Restaurant offers a beautiful view of the track, although the Speedster Café has some excellent treats/drinks as well. Let's not forget the Simulator Lab, where you can test a range of (digital) Porsches!

Located about 20 minutes south of LAX, Los Angeles' international airport, the PEC has been a hit with Porsche fanatics of all ages since it opened over a year ago. Want to visit? Feel free to pencil in the address: 19800 South Main Street, Carson, CA 90745. And don't forget to visit [www.porschedriving.com](http://www.porschedriving.com).





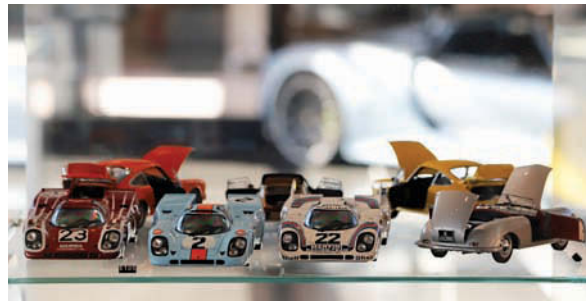

Far left: Sitting idle – the 1972 Kremer-Porsche ST, a stellar entry in the '72 European Grand Touring Championship

Left: The store offers reasonably priced though highly-detailed models, as well as some seriously high-end examples



Left middle: Jointly developed by Porsche and March, the 1988 88P single-seater was campaigned in the CART series, marking the start of Porsche's attack on the US-based race series



Left: Mark Donohue successfully raced the Can-Am 917/30, running a 1200+bhp 5.4-litre flat-12





**356 Coupè and Cabrio  
T2 / T5 / T6 / C  
front vent window left/right**

**each 669,00 EURO**



**356 Coupè and Cabrio  
T2 / T5 / T6 / C  
upper frame for front vent window  
left/right**

**each 226,00 EURO**



**356 BT6 / C / SC Coupè and Cabrio  
Chrome Pivot bearing for front  
vent window**

**95,00 EURO**



**356  
operation mechanism rear quarter  
window left/right**

**each 293,00 EURO**





# MANFRED'S THE MAN

**In just 11 years, Manfred Hering has accumulated no fewer than 400 Porsches – and counting. To find out more about the man and his cars, *Classic Porsche* paid a visit to his Early911S compound at Wuppertal. Prepare to be amazed**

Words: Johnny Tipler Photos: Antony Fraser

**T**here's a sea of 911s – all 400 of them – in every room we pass through in Manfred Hering's expansive ex-factory premises. Many of us have just the one Porsche; four would be some kind of wonderful. But 400? How does someone manage that? We all know the odd collector with 20 or 30 cars, perhaps, but this is taking things to a stratospheric new level.

This is our third attempt at catching Manfred, and it's third time lucky. Tall, fit and personable, with a dynamic streak, he's based at the promisingly upbeat city of Wuppertal in north east Germany, and my snapping colleague and I spend an agreeable night in the cobbled heart of the place, among stately slate-hung 19th century buildings.

Absorbing my new surroundings and comprehending what Manfred's got here, it takes a while for the enormity of it all to sink in. This is Porsche Grand Central: every way you turn there's a sea of distinctive coupé roofs, and we're confronted by an amazing range of colours, from Rubystone to Magenta, Guards Red to Ivory White, with Racing Yellows, Oak and Mint, dotted with miscellaneous race liveries.

This collection and its associated restorative activities are currently housed in an 8000-square metre building, composed of seven adjoining units, set in a semi-rural compound on the fringe of Wuppertal. Space is not an issue: there's even a two-acre carpark in front of the building.

The collection is comprised of very rare and special

*Below: Manfred Hering is on a mission to save the world's depleting resources of 911s...or so it seems, with over 400 cars at his Wuppertal premises!*







*Above: Manfred prides himself in producing only the finest work, as anyone who has looked at his company's projects at events like Techno Classica will attest*

Porsches, and mainly 911s. Manfred employs 75 people on site, and confidently predicts that next year there'll be over 100. All the cars belong to him: they're not merely in storage for clients. 'My concept is to buy every car that I think is right, provided I have the budget for it, and then we keep them, and if a potential client wants to take a look and finds one he wants to buy, we can then restore it so it's 100 per cent original.'

The methodology is fairly traditional: 'For example, the car comes in, we dismantle it and assess what is original and what is not, and then we begin the restoration.' So, the bodyshell goes off for blasting, and all the running gear is evaluated and re-fettled, while the engine and gearbox go to the powertrain workshop to be rebuilt.

In spite of the fact that Manfred clearly has catholic tastes when it comes to Porsches, and 911s in particular, he does have strict criteria when he's buying cars; and as for vintage, the clue's in the name of his company, Early911S – for the time being, anyway.

'It has to be a rare model,' says our host, 'or a special car with a special history. For example, we have several factory press cars – the first 993 Turbo with the official Porsche press logo, and we have special colours; we have 2.0-litre 911s but

only '64 and '65 cars. Then we have all the 'S's, so, the 2.0S, 2.2S, 2.4S, and 2.7RS, plus all the Carreras, 2.7 and 3.0 from '74 to '76, and all related 930 Turbos.'

Although there are several modern Porsches in evidence, the vast majority are, indeed, older models. 'At first my plan was only to concentrate on early 911s, which means from '64 to '73, but my ideas are changing all the while. Right now, the next plan is to do just the water-cooled cars, but they have to be very special, like the 996 GT2 RS and 997 GT2 RS, so it's just creeping into a different era.'

The condition is not so important, as his operation is geared towards perfect and immaculate restorations. 'These are concepts; this is a 2.7RS we got last week from New York, so right now the client wants to have it like this quality you see here, original but not over-restored. And right now, the cars are coming from all over the world, and clients get a two- or five-year warranty once their car is finished.'

Forward planning is crucial. 'We're not restoring just one suspension set at a time, we order up or manufacture maybe 50 components; we're not only doing it for one car, we do it for a minimum of 20 projects.' This enables him to make economies of scale on aspects like plating. 'During the last two years we've

*Below: Restoration shop is prepared to undertake work on any model in the 911 range, classic or modern, including the Carrera RS*







been restoring a couple of special cars, and we are fitting special parts, too – original, not reproduction. In the big garage, we have around 2000 square metres filled with just parts.’ Some components are obtained from fellow specialists, though if there’s a hold up or a question over quality he will have the items specially made, with extras produced for stock and resale.

Our perambulation through jaw-dropping Nirvana continues. Obviously, Manfred dabbles in special colours, too. ‘This 964 RS Clubsport is the only one in light green,’ he tells us, ‘and we have a 3.3 Turbo in Rubystone red with matching leather upholstery, and the only left-hand drive Maritime Blue 3.6 Turbo. Everything is very special, and we’re always looking out for unique cars. We have the original ’74 BB (Rainer Buchmann) Rainbow 911 Targa, a couple of prototypes, and right now we have seven Speedsters here.’

One gem after another: a 901, a ’67 soft-window Targa S, a ’69 ST, a 356A police car – one of 30 different police cars in the collection. Given my camera-toting colleague’s affinity with the GT3 he can’t resist asking about the GT2 RS we encounter: ‘Yes,’ says Manfred, ‘it is a street car, and we’re just starting on it, though it’s only done 3000km. It was stored in a garage after only two months’ driving, so we’re mainly just cleaning it and giving it a light restoration.’

Moving on, here is the first 993 Turbo press car, which featured on the cover of *Auto Motor und Sport*, and several brochures and posters. And here is the last 993 Turbo S, and the second-to-last 993 Turbo with VLS power upgrade; a 968 Turbo S press car, the ’74 Carrera Turbo 3.0 press car – which is the Ferry Porsche car and (allegedly) the oldest 3.0 Turbo in

the world, as well as the only Porsche with a date calendar.

Here’s a ’74 Carrera 3 East African Safari rally car, and a ’74 Carrera 3 Acropolis Rally car; and a unique 2.0 design study from 1966 carried out by Aachen University. ‘I bought it last year in Switzerland; the 86-year-old lady was still driving it until last year. In fact, they produced three,’ says Manfred; ‘there is a sport coupé, a third one in Switzerland, and that’s the nicest one. This is quite ugly, but the objective then was to create a more refined aerodynamic shape. In the end, they didn’t produce it, and actually that’s not a bad thing! I would like to keep it like this, and maybe we do the mechanics so

then it can be driven, but right now we don’t have time to do anything on it.’

Other synergies come into play: ‘I work with Neil Bainbridge (BS Motorsport, Banbury UK) a little bit, and he’s the best engine man, and I also work now and again with

## “WE’RE ALWAYS LOOKING OUT FOR UNIQUE CARS...”

Lee Maxted-Page – they have a tremendous reputation for quality, they are on the same level and that’s the most important thing. They take care about what is original and what is not original, and change it accordingly.’

Manfred ushers us into another adjacent warehouse: ‘We have suspension system and body parts here, and we have around 600 engines, too, and around 150 project cars for total restoration. And we have two more warehouse spaces with much the same content...’ So, not only have we got innumerable shelves and racks full of components, we’ve also got project cars four layers deep.

He is clearly in this for the long haul, and the sceptic in me

*Above: This photo gives you some idea of what a treasure trove this place is, with bodyshells stacked four-high on racking, and the floor lined with cars under covers*

*Right: Not every car is a project in waiting – Manfred also owns an enviable selection of quality Porsches, ranging from 356s and early 911s, to 914s and modern GT2s. We also spotted a 928 ‘interloper’ amidst earlier air-cooled siblings...*









wonders if they will ever see the light of day, or at least the open road. The quantities are almost overwhelming. 'For example, if you're looking for a 2.7 RS or RSR fuel tank, we have around 100 original plastic tanks; everything is original. Outside in the yard we also have so many special things, like this 2.7 RS Lightweight prototype, and this '89 964 Targa press car, finished in Gulf orange outside, Gulf orange inside.'

It hasn't been a lifelong obsession, far from it. Manfred started off in 2004 with two 911s, and travelled around Europe searching for parts, visiting other long-term specialists, such as Ruf. 'I'm more into communicating with people, so I love to meet people, but I can't change a brake or something mechanical; I can't work on the car, but on the other hand, if I go to visit people in Rio de Janeiro, say, and take a look at a car, after one hour I can tell how much it will cost to restore it.'

Time is another factor. Clients need to appreciate that a restoration project could easily take two years, or more. 'Right now, we have around 50 projects that we are working on, and even after all the parts have been made or refurbished it will

take around two months to reassemble, and then we test it for up to 2000 kilometres. The main problem is usually the bodywork, and we have eight people on that right now. We're looking for more talented people with a background and depth of experience, ideally young people, because we want to develop the business over the next 30 to 40 years.'

Manfred plans to build on two more sites in Wuppertal with similar capacity, and anticipates significant expansion at the present site. 'Then we can do engine

testing, we can do painting, we can have 260 cars in storage, and across the border in France we need to have a little showroom and a duty-free zone, because if we buy nice coloured cars from Japan we can put them in there and we don't have to pay tax in Germany. If I sell such cars in Germany I have to pay, but if I export it back to America or anywhere else then I don't lose the 10 per cent.'

Manfred's interest in Porsches goes back to when he was

*Above: Manfred has a soft spot for the unusual, and his collection includes the unique HLS Porsche, which we featured in issue #30. Behind it is a more recent acquisition, one of just three design studies built by Aachen university*

## “IT HASN'T BEEN A LIFELONG OBSESSION, FAR FROM IT...”

*Below left: Dedicated engine shop carries out rebuilds in-house for the many restoration projects*

*Below right: Fuchs wheels, Fuchs wheels and more Fuchs wheels...*





MADE IN GERMANY  
**EARLY  
911S**

[www.early911s.de](http://www.early911s.de)

EARLY 911S E.K. | WESTRING 416-418 | 42329 WUPPERTAL, GERMANY

# FIRST EXIT WUPPERTAL

The Destination for Classic Porsches







aged eight, and his grandfather, who was a gardener, had an old 356. But it took another 27 years before he actually owned one himself: 'I studied economics and engineering, so although I like the design, the first Porsche I bought was when I was aged 35; and now I'm 48 so it wasn't so long ago.'

As a young man, Manfred was a professional tennis player, travelling the world on a bicycle. The former cycle racer also has some Porsche bicycles in his collection: 'we have every Porsche bicycle, and we have a guy who restores them.'

However, it was a classic English model that kick-started his current career. 'My first old timer was an Aston Martin DB5, which I bought in Germany and took to a German restorer, but it wasn't good, so then I got a '66 911 in Slate Grey, and two more for parts.'

'I love all Porsches that are 100 per cent original and the best quality, and I love the stranger colours and the rare cars, with special things like press cars and racing cars. I have around 25 Cup Cars including the Altfred Heger 1993 Super Cup-winning 964, and we restored the Steve McQueen Le Mans car for a customer, which he'd bought in California. To my mind, this is the only car which combines the personalities of the car and a famous person like Steve.'

There are indeed a number of racing 911s on site, but Manfred only likes to own the cars; he doesn't entertain the idea of actually haring around the circuits with them. 'I like Porsche, I love the design, but I don't particularly like to drive them, so that's the difference between me and most people who like to go on the race track.'

'We don't do a racing service either, because you need a special team for this, and if they are involved on the racetrack they also have to work before and after the events, and this is a very expensive consideration and not many people want to spend the money for this; and we have a lot of space, but not enough space for a racing workshop.'

'We don't do prototype race cars either,' he continues, 'so you won't see a 906, 910, 917, 935 or 962, for example.' We glance at a 993 C4 that's bound for Bahrain, 'Take a look at the mileage,' says Manfred. I blink and look again: 656,000km. 'It's still on its first engine, too! If I had the time I would drive it for a year and take it up to 1,000,000km; that would be a nice story. It's proof, if proof were needed, that if you look after your 911, your 911 will look after you.'

When you've got that many Porsches in one location, security is paramount. 'Everything is very safe here, because our oil system and our petrol system is outside the building. So, if we are dismantling a car, first we drain all the oil and the petrol outside, so if something disastrous happened we wouldn't have such an intense fire.'

Manfred draws our attention to the Trim Shop, looking at – smelling, too – all the different hides and carpets, plus maybe 1000 steering wheels. Then there are Fuchs wheels, wiring for the looms, radios and trim pieces. Our guided tour proceeds to the engine shop, workstation for eight technicians.

Manfred is scathing of restorers who use parts that fit but are not from the correct build-series programme. 'Because we have 400 cars here we have plenty of reference material to see what they changed on the production line, so we know precisely

*Above: While Early911S may not have a dedicated race shop, or work on prototype racers, such as the 906 or 908, it isn't averse to handling 911-based cars*

**“I LOVE ALL PORSCHE  
THAT ARE 100 PER  
CENT ORIGINAL...”**

**Contact:**

Manfred Hering  
Early911S  
Westring 416–418  
42329 Wuppertal  
Germany  
Tel: +49 (0)202 769220  
[www.early911s.de/en/](http://www.early911s.de/en/)

Thanks to Stena Line for the luxurious North Sea crossing, Harwich to Hook of Holland [www.stenaline.co.uk](http://www.stenaline.co.uk)



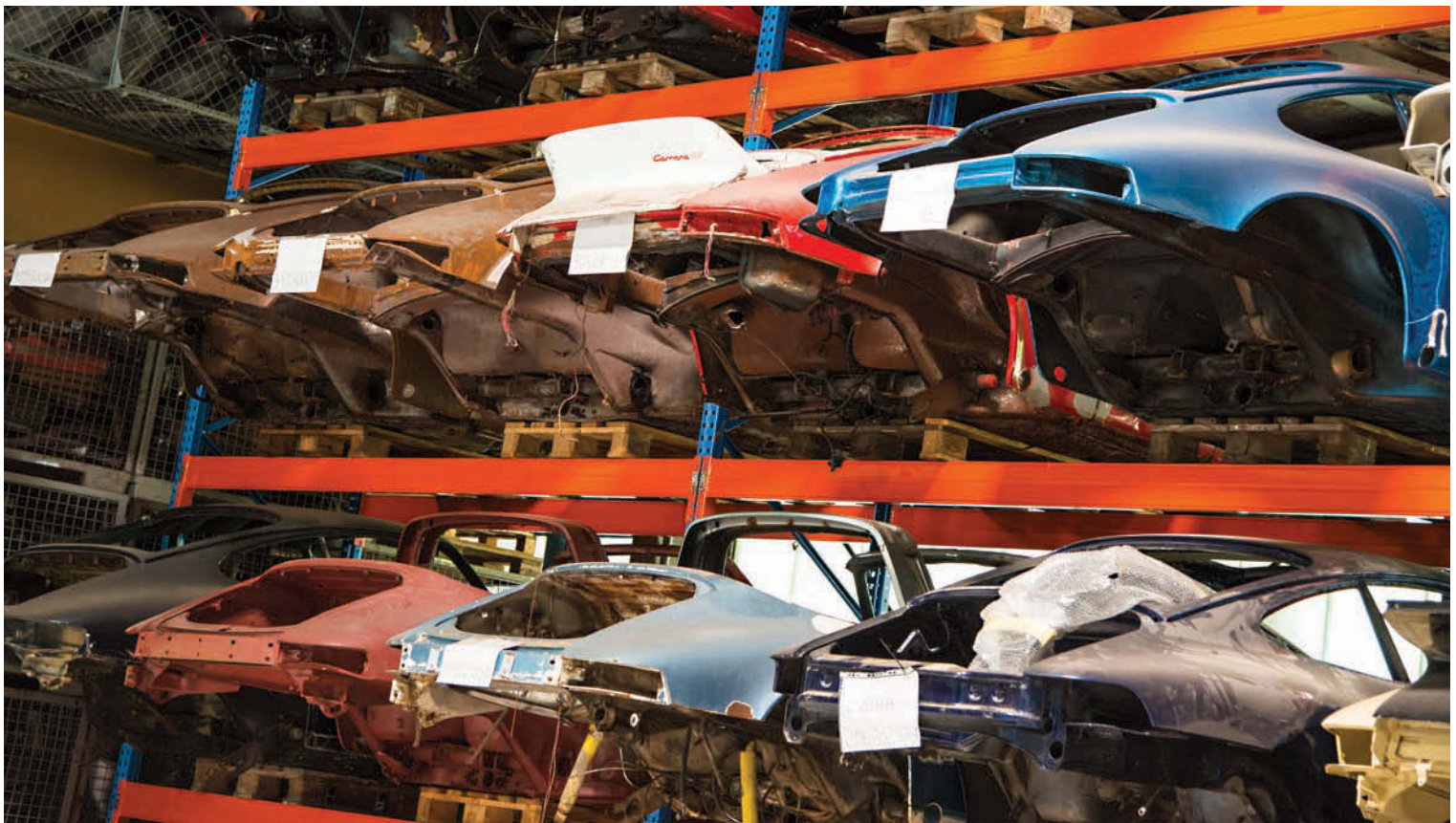

*Above: Close-up of the racking carrying a huge range of bodyshells carried 'in stock' by the Wuppertal-based company. Need a starting point for a restoration? Look no further*

*Below left: Whatever age and design of steering wheel, you can pretty much guarantee there'll be one to match any project*

*Below right: Who said old Porsches came in red, black or silver?*

what parts belong with every model year.

'Every wreck has a project list, so it's easy to know what we have to buy, or what we have to reproduce to restore that car.' Again, we hear the originality mantra. 'When we are dismantling engines, we check that all the parts are original; for example, take a look at this '65 car: they restored the engine a couple of years ago with '67 and '68 parts, but we restored it how it should have been with matching '65 parts. If it's a matching-numbers engine, then all the engine parts are matching, too.'

All componentry passes through some sort of restoration process before being reinstalled; 'every part, every screw has to be new. All the pumps are renewed, and we are using only new pistons.' Manfred operates a bit like a detective agency, finding exactly the right parts for a specific car. He won't necessarily go to Zuffenhausen to find them, and instead he communicates with a global network of specialists.

'You may have to renew 200 parts in the process of a rebuild, so if it's an 'F' model 2.4S, it doesn't make sense if they install 'G' model parts, because they're simply converting it to the 'G' model. Sourcing new pistons, I buy them from Mahle,

and I pay €3000 for a set, which is half the price from Zuffenhausen. We do a lot of re-manufacturing; for example, we make a complete new wiring loom for every car.' That's serious commitment!

Manfred doesn't have a favourite Porsche, though he will admit he likes the original 930 Turbo. 'I love the 3.0 Turbos most because they are 45 years old, and if you restore it you can drive 270kph in an old car. You appreciate that it was the ultimate Porsche in the '70s and they could engineer cars like this back then. And then if you drive a modern GT2 RS it has the same values of build quality and performance. I drive around 80,000km every year so I love my modern Porsche Macan in that respect.'

And the icing on the cake? Manfred plans to open a museum that will showcase 100 special cars. 'We'll do something like a show, but not a big museum that's open to the public, but aimed more at the collector so they know the quality, and I think it will be good for Porsche, too.' Jealous? Me? Not of someone who's accumulated over 400 Porsches... He is way out of my league; on a planet of his own – we'll call it the planet Wuppertal. **CP**

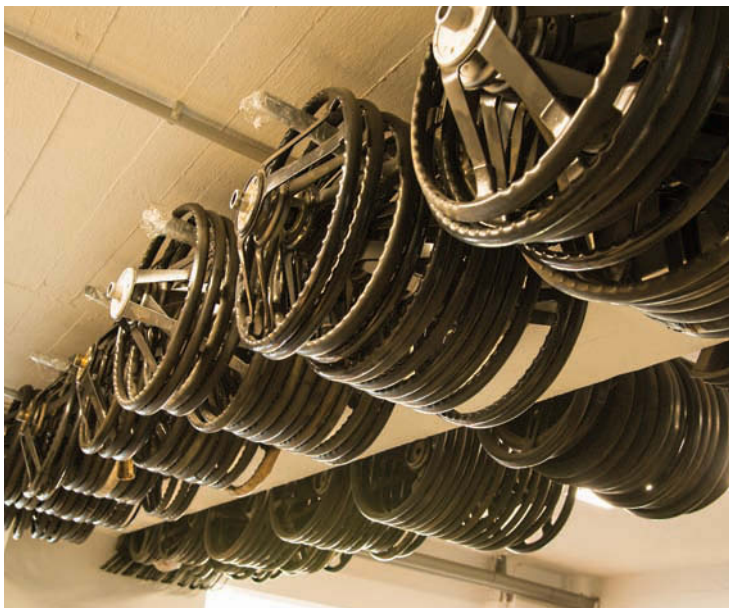





New from KK exclusives!  
Our own early 911 / 912  
Puck style horn push.  
Perfect fit. £250+ vat.

65-73 911 Tool kits & Jacks.  
Tool Kits from £450+ Vat.  
Jacks from £200+ Vat.  
All 356 models available.



We stock 'Simonsen 356 repair panels. They are regarded as the best you can buy, anywhere!  
We are the sole UK distributor.  
Please call or mail for prices!



Exclusive to KK.  
Stainless steel  
Sebring Exhaust.  
Fits 356 & 912.  
Standard £650+ Vat



Super discounted offer!  
356 B / C Les Leston  
KK exclusive reproduction  
Previous price from £650+  
Now Polished £395+ vat  
Machine turned £445+ vat

A pair of excellent quality headrests correct for all Porsche 356, 911 & 912 up to 67. The headrests are a KK exclusive and made in house. They come ready to upholster. £250+ Vat.



Leather Hood Straps as fitted to the 'GT's, supplied as a pair and complete with all fittings in Black, Antique burgundy & tan. £130 + Vat.



Pair of brand new Euro spec Bosch headlights, available for LHD or RHD cars 64-68. The Headlights look superb and come flat Bosch lens (non H1) and correct chrome ring (not VW). Available exclusively from us at KK. £584+ Vat.



Speedster spare tyre straps, fabric as per original. £105+



Find us on ebay for used parts and rare accessories.  
Follow us on Facebook for the latest news and offers!

**See Website for more products, special offers & Cars for sale!**  
**www.karmannkonnektion.com info@karmannkonnektion.com**  
**TEL - 01702 340613** The Golden Lion, 289 Victoria Ave, Southend, Essex, SS2 6NE

©2016 Lufteknik LLC Lufteknik has no affiliation with Porsche AG. Porsche is a registered trademark of Dr. Ing. h. c. F. Porsche AG

# Glorious to drive again!

1969 912  
Lufteknik restored 2014



Restoration - Parts - Service for Porsche  
www.lufteknik.com





# Your Porsche.

Whatever model Porsche you own, modern or classic, we have the expertise, knowledge and experience to make sure you spend more time enjoying what your car was built for. Driving.

- Four wheel alignment and corner weight gauges
- Bodywork repairs
- Engine rebuilds and race engines built to spec
- Alloy wheel overhauls and colour matching
- Menu servicing with free MOT offer
- State of art diagnostic machine for all models
- Interior refurbishment, connolesing and trim work
- Mapping and tuning for all late models
- Stainless steel exhaust systems and upgrades
- Air conditioning repairs and regassing
- MOT tests
- Vehicle inspections and valuations



Independent servicing and repair specialists for classic and modern Porsche.

**Call 020 8903 1118 or 01727 866 075 or visit [www.jazweb.co.uk](http://www.jazweb.co.uk)**

Unit 18, North Orbital Commercial Park, Napsbury Lane, St. Albans, Hertfordshire AL1 1XB



## PORSCHE

ENGINE BUILDING  
CLASSIC MOTORSPORT  
OEM & SPECIAL PARTS  
SERVICES

FACEBOOK.COM/MITTELMOTOR  
INSTAGRAM.COM/MITTELMOTOR.DE

BOCHUM / GERMANY  
T +49 234 935 14-14  
INFO@MITTELMOTOR.COM

# 20 YEARS OF RACING EXPERIENCE

**MITTEL  
MOTOR  
.COM**

EVERYDAY RACING

**MITTELMOTOR™**



# PORSCHE AT CARAMULO

The Portuguese are renowned for being mad about cars and motorsport but it's not only the modern WRC, MotoGP or the WEC they flock to see, classic events are also wildly popular. Called by some the Goodwood of Portugal, the 2017 Caramulo Motorfestival attracted thousands of spectators

Words: Robb Pritchard

Photos: Robb Pritchard and Pawico Frackowiak



**T**he small town of Caramulo started life as a tuberculosis treatment centre perched on the side of a mountain, then became a popular health spa, but is now famous for being the home of the oldest car museum in Portugal. Joao Lacerda, who began the collection in the 1950s, also had the great idea of turning the mountain road right in front of the museum doors into a hillclimb course.

The 2.8km route is now known as one of the fastest such courses in Europe. Even though the festival is only in its second year, it still attracted nearly a hundred cars with some coming from as far away as Italy and the UK.

For *Classic Porsche* magazine, Robb Pritchard was invited to see, and drive, the museum's newest acquisition, an absolutely immaculate 1973 2.4 911E. But there were some other beautiful Porsches there as well that warranted closer attention...

Only 144 914/4s were ever imported into Portugal and Paulo Almeida's beautiful example is one of about only twenty still in roadworthy condition, and currently the only one used in any form of competition. A friend owned it for many years and so when he put it up for sale Paulo knew it had been well treated and so made him an offer.

With the heads off to solve a small but persistent oil leak,

*Above: With straw bales instead of crash barriers, Caramulo captures the spirit of the glory days of hillclimbing back when the sport was a major part of the European motorsport scene*





he discovered that the engine wasn't quite as sound as it first appeared so had new piston rings fitted. A few times the car had jumped out of gear but replacing the gearbox turned out to be much harder, though, and he spent five months searching for a suitable replacement until he came across an almost new one at the back of a garage.

Apparently many years ago someone locally used to convert VW Beetles into beach buggies and liked to use the 914's flat-four engine, but for some reason not the 901 gearbox. Paulo couldn't believe his luck when he found one which had been put aside and forgotten about for nearly 40 years. To keep the car all matching numbers, Paulo took the

internals from the garage find gearbox and installed them in the original casing.

Paulo prefers the 914 body because it's different from the ubiquitous 911s and so the car gets more attention...and being mid-engined, it handles much better as well, although he admits most of his 911 owning friends disagree with him!

The car is too well cared for to do outright speed events but he loves regularity rallies whereby the co-driver has to work out the correct average speed over a set distance, something which is much harder than it sounds. At the 2016 festival he won the class that included all cars from the 1970s and '80s, but for 2017 the regulations were changed

*Above: Following the demise of its Ferrari F40, the museum purchased this immaculate 1973 911E to showcase the collection. It's only covered 23,000km and drives like new*





to include all cars, so he was driving more for fun than for outright position. It didn't matter much though as in his opinion Caramulo is a cathedral for classic cars, so even if he wasn't winning he was still enjoying every minute of being there.

Since the late '70s when Pedro Diogo thumbed through his father's car magazine collection and came across the spaceship-looking 928, he's been in love with the striking lines. His father owned a succession of 912s and 911s but when Pedro came of age and could afford his own Porsche it was a 928 he chose...

His untouched and all original 1977 example is now his fifth, and is one of his favourites. He got out an old piece of paper to show me why. 'It's number 087,' he said with a smile.

'They started with #011, the first 30 were press cars and two were for the 1977 Geneva motor show, so it's one of the very earliest ones and was made in the first week of production.'

For 928s the earlier the better as Pedro feels, along with designer Wolfgang Mobius, that the later additions of wings and spoilers detracted from the original design.

So the ones added to this car to make it look like a later model will be coming off soon.

Pedro has been to every Caramulo hillclimb, always in one Porsche or another, but this is the only time this particular 928 will ever go up. Bought a few months ago it is about to undergo a full restoration to bring it back to its full glory, so the oil smoke

*Above: The 914 is a museum favourite because it handles so well, but also makes a refreshing change from all the 911s!*

## “CARAMULO IS A CATHEDRAL FOR CLASSIC CARS...”

*Below, left and right: The atmosphere at Caramulo has been compared with that of the Goodwood Festival of Speed, where members of the public can experience the cars up close*







Above: Modern smart phone is the weapon of choice for plotting the schedule!

Above right: Early 928 is a recent addition and dates back to 1977. Silver car is due for a full restoration

Below: Original paperwork shows that the 928 is number #087, the first car off the line being #011

Below right: 911E heads off up the course...



mixing with the tyre smoke off the start line was nothing to worry about. When the work is finished it will be well looked after and only taken out for gentle cruises in good weather.

Also thoroughly enjoying the weekend was Cecilia, the wife of Joao, the museum founder's grandson. The glorious signal yellow 1973 2.4 911 E, which is the newest addition to the museum, was being shown off to the enthusiastic crowd...and came into the collection as a result of a Ferrari crash some 20 years ago!

Joao had been driving the museum's, and his grandfather's, F40 up the hillclimb course since he was 15 years old, so was pretty used to its handling and power. But one day a dog ran out into the road in front and the instinctive attempt at avoidance ended up with the F40 wrapped around a tree and Joao lucky to be alive.

The remains were retained, as somewhere in the smashed glassfibre and twisted metal was the soul of his grandfather's Ferrari, but with prices being what they are these days he decided to sell the engine and salvagable

parts and put the money towards another special car for the museum. With not a single exhibit bought for the collection in the last 10 years, it needed to be a special car, one people would want to come and see, so an air-cooled Porsche was an obvious choice.

Apart from being drivable Joao wanted the new car to be as original as possible. To an untrained eye, as long as the numbers stamped on the engine and gearbox are the same as on the paperwork it's a matching numbers car...but Joao doesn't think it's as easy as that, which is why he enlisted Portugal's pre-eminent 911 historian to help.

The first few cars he saw weren't quite what they were advertised as and so were passed over, but through a friend of a friend he heard about one that was about to be put up for sale. The spectrum analysis tests showed that this car hadn't been tampered with so, after viewing the car, Joao became the proud owner of an unrestored 1973 911E with just 23,000km on the clock.

The start of his ownership was a little inauspicious,







though, as when he picked it up and started it a red light in the instrument panel flashed red over the letters OEL... which he assumed meant 'oil' in German. Disheartened, he called his mechanic, who arrived and explained that it was the handbrake 'on' warning sign!

To fully demonstrate the car Joao suggested to me that instead of standing in the crowd the best place to experience the car was in it. And not just as a passenger, either. First impression was that the car had just had a very serious rebuild as it felt so new. The engine started straight up, the red OEL light went out when I released the handbrake, and the clutch, which has never been changed, felt perfect.

The spectators had been watching the competition and a tyre burning drift car had just gone up the course to reverberating applause and a racing truck was on the line in front of us...but if anyone was waiting for a spectacular tyre-squealing run they were disappointed. In 1973 this was a new sports car but its pedal to the metal days are over now –

today the museum piece takes its time up the hillclimb.

The E line of 911s was conceived to fill the gap between the sport-oriented S (super) and slightly down-tuned T (Touring), and with this being a '73 model it is one of the last made. It was also mooted as the most luxury version of the range, although the definition of luxury has changed somewhat over the intervening 45 years.

For its day, though, ventilated front discs, leather steering wheel, velour carpets, chrome rocker cover trim and gold lettering on the back was the height of sophistication. One slight discrepancy is that the engine cover is from a 2.7, but Joao will be getting that changed soon.

Driving any Porsche is a pleasure but the Caramulo Museum's newest car is such a low miler it offers more than just the experience of driving a classic car – it's like really going back in time. It is honestly the nicest 45-year-old car I have ever driven. But I am not too sure that I could feel the soul of the F40 in it, though... **CP**

*Above: Caramulo is an excellent way to see the cars close up, and for the owners to enjoy them in a non-combative environment*

*Below, left and right: You could be forgiven for thinking that a 911E would be no substitute for an F40, but you'd be wrong as the 911 coupé has proved every bit as popular with visitors*





**ZIMM**  
AUTOTECHNIK  
PORSCHE SPECIALISTS

ORDER ONLINE  
[www.allzim.com](http://www.allzim.com)

PARTS FOR ALL PORSCHEs • LOW PRICES • FAST SHIPPING

Kupplung  
Clutch  
Embrayage

RECHARGER.  
MOTIVE PRODUCTS  
POWER BLEEDER  
PORSCHE  
BOSCH  
PERMA LITE  
OC 54  
Oil-Filter  
BOSCH  
BOSCH

FedEx UNITED STATES POSTAL SERVICE

1804 RELIANCE PKWY. BEDFORD, TX 76021 USA

VISA MasterCard DISCOVER AMERICAN EXPRESS

Fax: 001-817-545-2002  
Phone: 001-817-267-4451

**SPECIALISTS IN CAR SHIPPING AND TRANSPORTATION**  
Worldwide export and import services

• Customs clearance • UK & European collection & delivery  
• SAFE • SECURE • COMPETITIVE

t: 01394 695566 f: 01394 673031  
kevin.lewis@rjffreight.co.uk chinita@rjffreight.co.uk [www.rjffreight.co.uk](http://www.rjffreight.co.uk)

**Lakewell.com**  
CLASSIC PORSCHE INTERIORS

356 | 911 | 912 | 914 | 928 | 964 | 993  
TRIM & INTERIOR PARTS TO OEM SPECIFICATION

LAKEWELL PORSCHE INTERIORS WEB: [WWW.LAKEWELL.COM](http://WWW.LAKEWELL.COM)  
KLEIN HEIDESTRAAT 71 EMAIL: [INFO@LAKEWELL.COM](mailto:INFO@LAKEWELL.COM)  
B - 3370 BOUTERSEM PHONE: +32 (0) 475 53 56 22

**Greatworth CLASSICS**

**Sales \* Restoration \* Servicing**  
*Your Lifestyle, Our Profession*

**01295 812002**  
[www.greatworthclassics.com](http://www.greatworthclassics.com)

**[www.clubautosport.co.uk](http://www.clubautosport.co.uk)**  
*Porsche Specialists since 1971*

**WORKSHOP FACILITIES** - servicing, repairs, diagnostics, inspection engine & gearbox rebuilds, MOT work

**FULL BODYSHOP & REPAIR FACILITIES** - paintwork, bodystyling & conversions, restoration, welding, accident damage repairs, bespoke modification i.e backdates/updates

**NEW AND USED PARTS** - any part for any Porsche, from engines and gearboxes, body panels to small trim parts

**LIGHTWEIGHT COMPOSITE PANELS** - manufactured in house panels and styling conversions. All models from early SWB 911's to 997 RSR Supplied in fibreglass, Kevlar or carbon doors, roofs, bonnets. The list is endless

**SINGER INSPIRED CONVERSIONS AVAILABLE NOW**

Next day delivery or collection  
**Tel: 01384 410879**  
email: [richard@porscha.co.uk](mailto:richard@porscha.co.uk) or [mick@porscha.co.uk](mailto:mick@porscha.co.uk)  
Park Lane, Halesowen, West Midlands, B63 2RA



# BRAKING WITH TRADITION

**Classic Porsche follows the path of automotive brake design and development, and how Porsche applied it to its cars, from the earliest drum-braked 356s to the first of the Turbos**

Words: Keith Seume

Photos: Porsche Archiv and author



*Above: For many the ultimate braking system for the 911 was the 917-derived disc and caliper assembly used on the later 930 Turbo*





Above: Jaguar's Le Mans-winning C-type of 1952 is generally credited as being the first performance car to rely on disc braking

**M**an has always been preoccupied with going fast – faster, that is, than he could walk or run. Who knows precisely when he first jumped on a horse's back and galloped towards the horizon, leaving his companions staring in disbelief. And who was the first person to bolt a set of those new-fangled 'wheels' onto a sled, before rolling out of control down a hillside?

The sensation of speed must have been pretty intoxicating, the exhilaration tempered only by the terrible realisation that, unless something was done pretty damned quick, there was going to be pain involved as human body met stationary object. While pulling back on the reins might work with a horse, trying the same approach with a piece of rope attached to an axle on a crude cart isn't going to achieve much.

The first braking systems were simple, consisting of nothing more than a wooden block being pressed against the circumference of a wheel. Interestingly, many railway wagons still use much the same set-up today – it's cheap and heat can be dissipated in part through the wheel and into the rails of the track. This only works as a design if the wheels are solid, without tyres, or are equipped with hard rubber solid tyres. It's not a great design as far as cars are concerned, for rather obvious reasons...

The advent of pneumatic tyres and the increasing speed of vehicles meant that such simple brakes were impractical, so automobile makers applied themselves to the development of alternative systems. Among these was a system designed by Oldsmobile, consisting of crude metal bands acting round a solid drum attached to an axle – as the band was tightened, so the vehicle would be slowed. But the bands wore out, stretched or broke. The whole band-based system also took up a lot of space.

A better alternative was the drum brake. The concept dates back to the late 1800s when it was used on carriages, but its first use in an automotive application is said to date back to 1902 and the designs of Louis Renault (there is also some evidence that Maybach may have beaten Renault to it by a year, but it remains unsubstantiated). The drum brake was the accepted norm in the automotive industry for the next 60 years, with the majority of mass-produced cars relying on four-wheel drum brakes until the mid-1960s.

The drum brake is a clever solution to the problem of how to bring a car to a halt. In simple terms, it consists of a cast-iron drum inside which two brake shoes are forced outwards, either by cable operation or hydraulics, to rub against a friction surface. The brake shoes were traditionally lined with an asbestos-based material, but this gave way to an organic-based material once

Below left: Lanchester applied for a patent in 1902 for a disc brake design – it was the true forefather of modern braking systems

Below right: Odd-looking Crosley was built in 1949 and was the first production vehicle to feature disc brakes

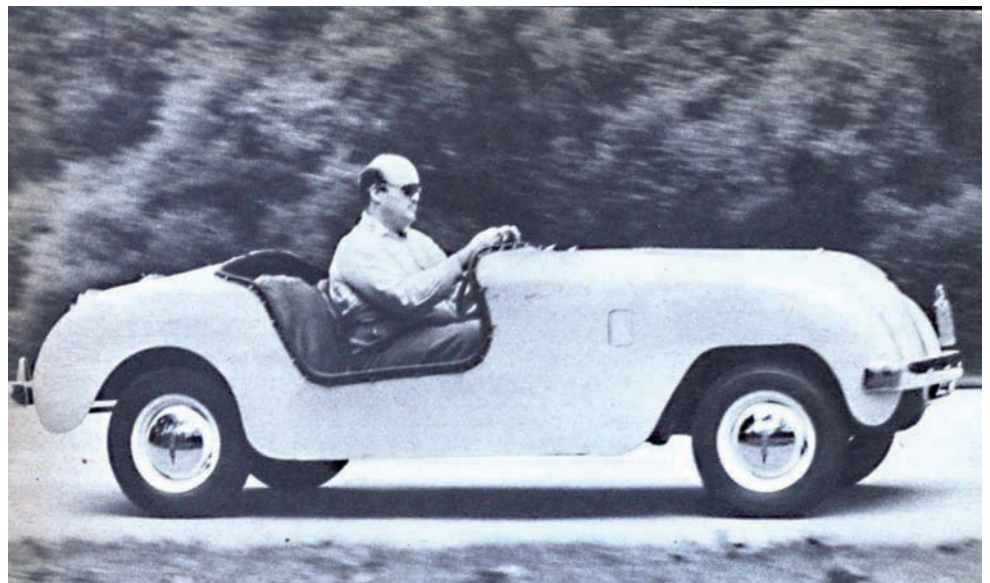
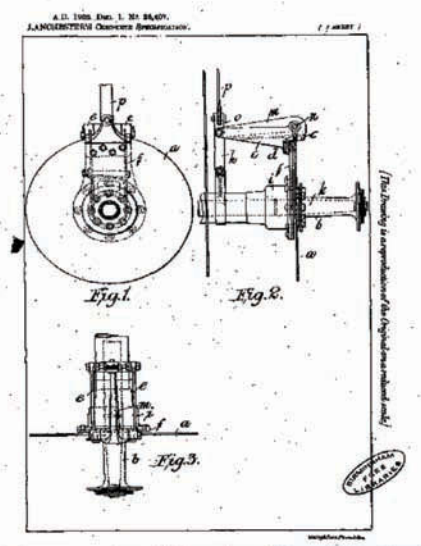



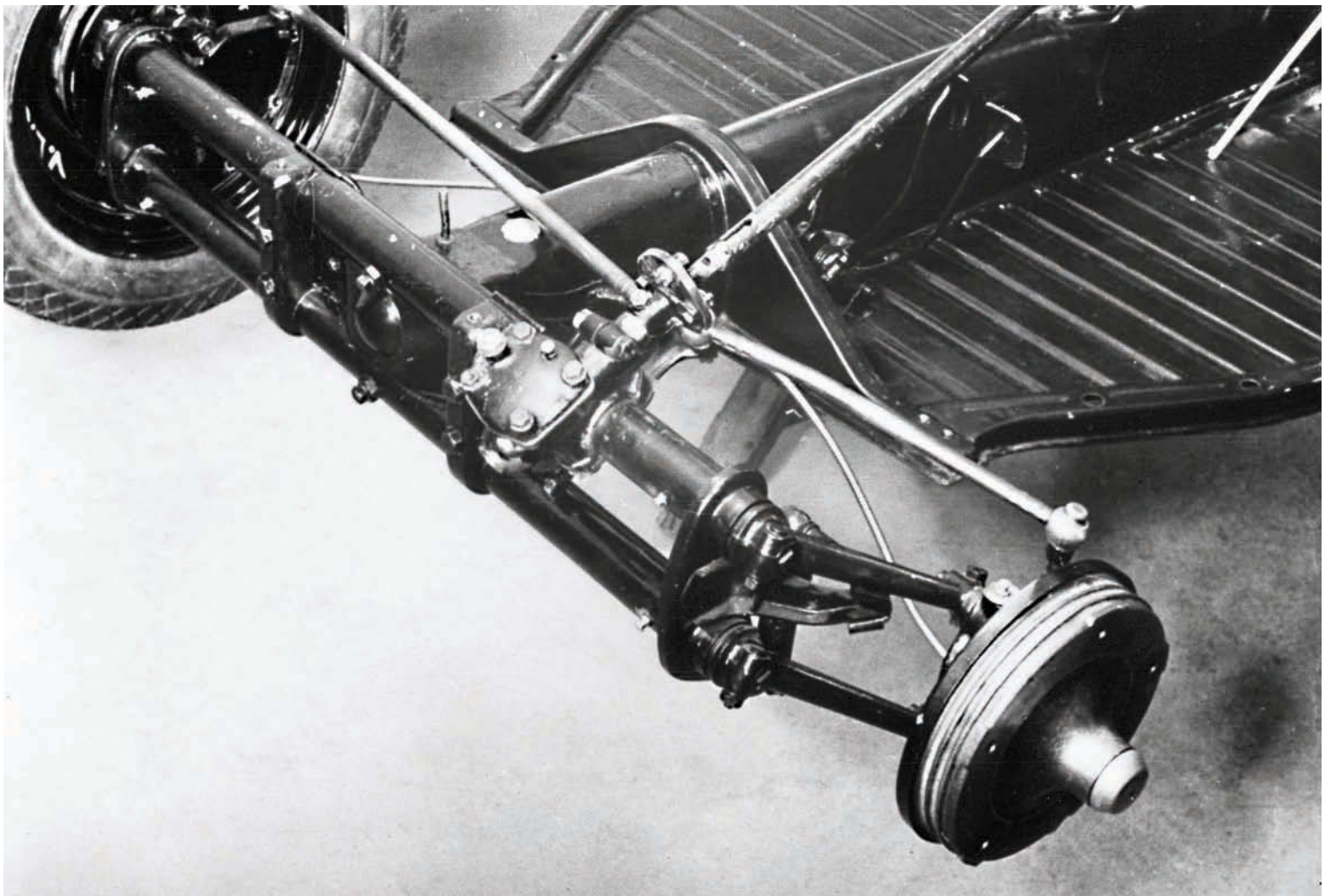

asbestos's rather nasty properties came to be fully understood.

The advantages of drum brakes are that they are – or can be – relatively compact, and are also relatively inexpensive to manufacture. However, a downside is that drum brakes are prone to fade, as they are not great at dissipating heat and, to improve their efficiency, you either need to increase the diameter of the drum, or its width. This was never a problem when cars ran large-diameter wheels, and even absurdly powerful, ridiculously fast pre-War Grand Prix cars such as Ferdinand Porsche's legendary Auto-Unions relied on huge drum brakes to haul them down from near-200mph speeds. In fact, take a look at almost every pre-War sports car – Bentleys, Mercedes, you name them – and you'll see they're equipped with massive drum brakes at all corners.

This was partly a case of braking systems taking advantage of relatively crude tyre technology – increasing the tyre diameter meant that the contact patch was correspondingly increased, giving better grip. Tyre development wasn't yet at a stage where reducing diameter and increasing the width was an option, so even racing cars were fitted with tall, skinny tyres and big drum brakes. It wasn't a perfect situation by any means, but it worked and everyone seemed happy, despite the inevitable tyre failures as horsepower increased beyond the tyre's capabilities.

Looking back, it seems a little odd that a majority of pre-War cars featured mechanically-operated drum brakes because in 1918, a certain Malcolm Loughead invented the four-wheel hydraulically-operated braking system. Loughead was a member of the Lockheed family, which was primarily involved with the aviation industry. His system relied on a master cylinder being used to push fluid through a network of small-bore pipework to smaller hydraulic cylinders mounted within each

brake drum, which forced the shoes outwards to make contact with the friction surface.

The first car to be equipped with four-wheel hydraulic brakes was the 1918 Duesenberg but it would take another decade before they became commonplace on other prestige marques, and another decade and a half before they became the norm across all markets. In fact, it was still possible to buy a VW Beetle 'Standard' equipped with cable-operated brakes right up until April 1962...

The first Porsche prototype, chassis number 356.001 of 1948, relied on mechanically-actuated drum brakes 'borrowed' from a contemporary VW Beetle. This was purely a case of Porsche being forced to use what was readily available, but by

the time the first coupé – chassis number 356.002 – appeared, Porsche was using four-wheel hydraulic drum brakes supplied by Lockheed. These were more efficient twin-leading shoe drums (ie, they featured two slave cylinders per drum,

each operating its own brake shoe) and were clearly far superior to the VW-based cable-operated brakes.

Unfortunately, by the time Porsche moved from Gmünd in Austria back to Stuttgart in Germany, the deal with Lockheed had fallen through because of a licencing agreement between Lockheed and Alfred Teves (better known as 'ATE'). For reasons which are unclear, ATE refused to supply Porsche, so the Stuttgart-based manufacturer was forced to look elsewhere. Fortunately, in 1950 Volkswagen had introduced its own hydraulic brake system, available on 'Export' Beetles, which Porsche opted to fit to the first Stuttgart-built 356s.

The cast-iron brake drums worked fine on Beetles but were a

*Above: Pre-war prototypes of the Volkswagen Beetle featured drum brakes all round, which remained little changed when the vehicle went into production post-war. The tiny cast-iron drums were adopted by Porsche for its earliest designs*

## “EVEN THE LEGENDARY AUTO-UNIONS RELIED ON DRUM BRAKES”



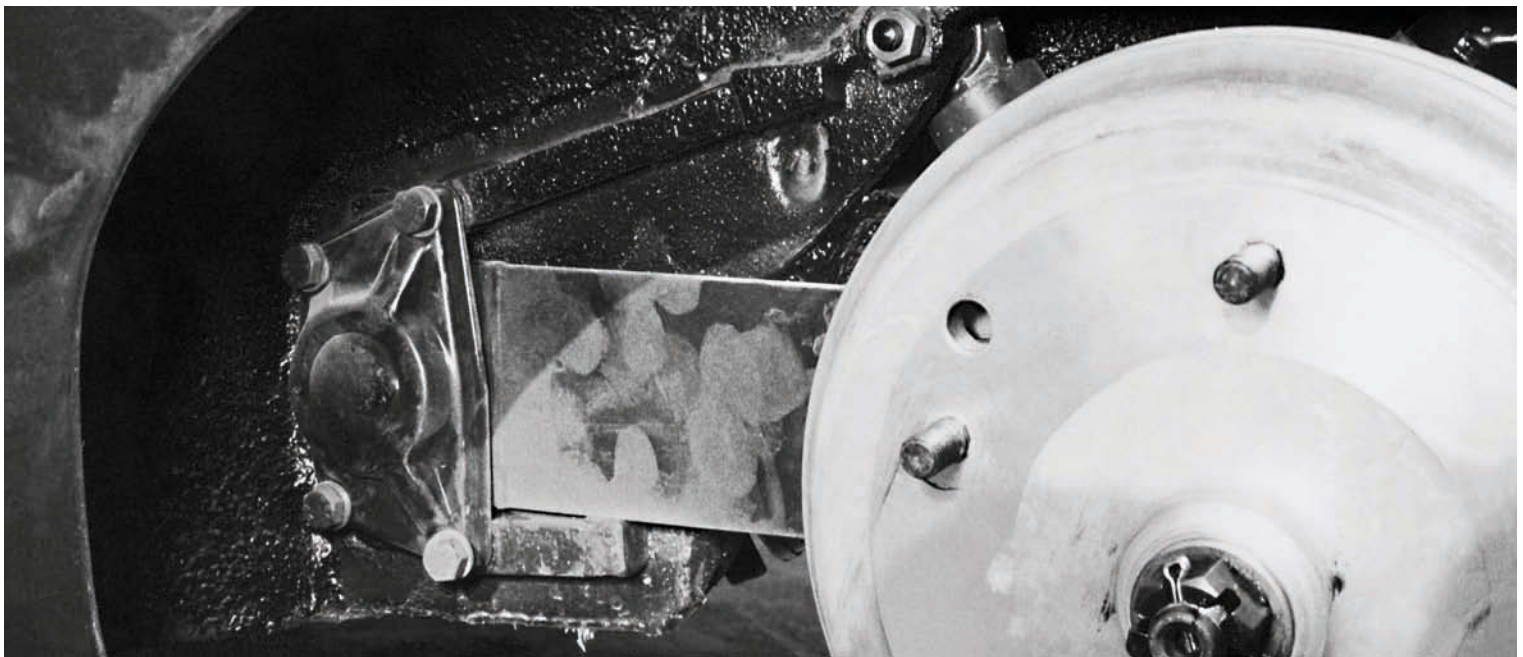

*Above: Porsche's 356 benefited from the adoption of large cast-aluminium drums with shrunk-in cast-iron liners in October 1952. Radial fins aided cooling and added strength*

little overstressed when used on the faster Porsches. The problem was fade, due to heat build-up when repeatedly braking from speed, such as on a race track. Porsche attempted to get round this problem by pressing ribbed cast-aluminium rings onto the stock VW drums. It offered a simple short-term solution but didn't prove to be particularly effective.

At around this time – and pinning down precisely when certain changes were made at this point in Porsche's history is not easy – Porsche began installing twin-leading shoe Lockheed/ATE drum brakes, which were 230mm in diameter. Then, in October 1952, they introduced all-new 280mm cast-aluminium drums which featured shrunk-in steel liners. These were a major improvement over what had gone before, with radial cooling fins which served not only to help dissipate heat but also to prevent the drums from distorting. The new brakes offered a 40 per cent increase in friction area yet still weighed around 1Kg less than the smaller cast-iron drums.

Porsche continued to use these radially-finned aluminium drum brakes until the introduction of the 356B model in 1959 when a new design of drum was introduced, featuring 72 lateral fins to further improve cooling. The ultimate drum brake used by Porsche was the heavily-finned 60mm-wide aluminium unit used on the 356 Carrera GT and originally developed for the 550 Spyder. Drum brakes remained in use on all 356s (with the exception of the Carrera 2, of which more anon) until the introduction of the 356C in 1963, with its four-wheel disc brakes.

Ah yes, disc brakes... Many people are of the impression that it was Jaguar which, with the Le Mans-winning C-type of 1952, championed the disc brake. Well, it's true, the C-type did carry four-wheel disc brakes, but the roots of the design go back far further than that – right back to the 1902 patent registered by Frederick Lanchester from Birmingham, in fact. Lanchester's design consisted of a steel disc riveted to the wheel hub. A simple caliper, resembling a pair of pliers with one jaw fixed to

*Below: With the advent of the 356B in 1959 came new brake drums, this time with axial finning to further improve brake cooling*

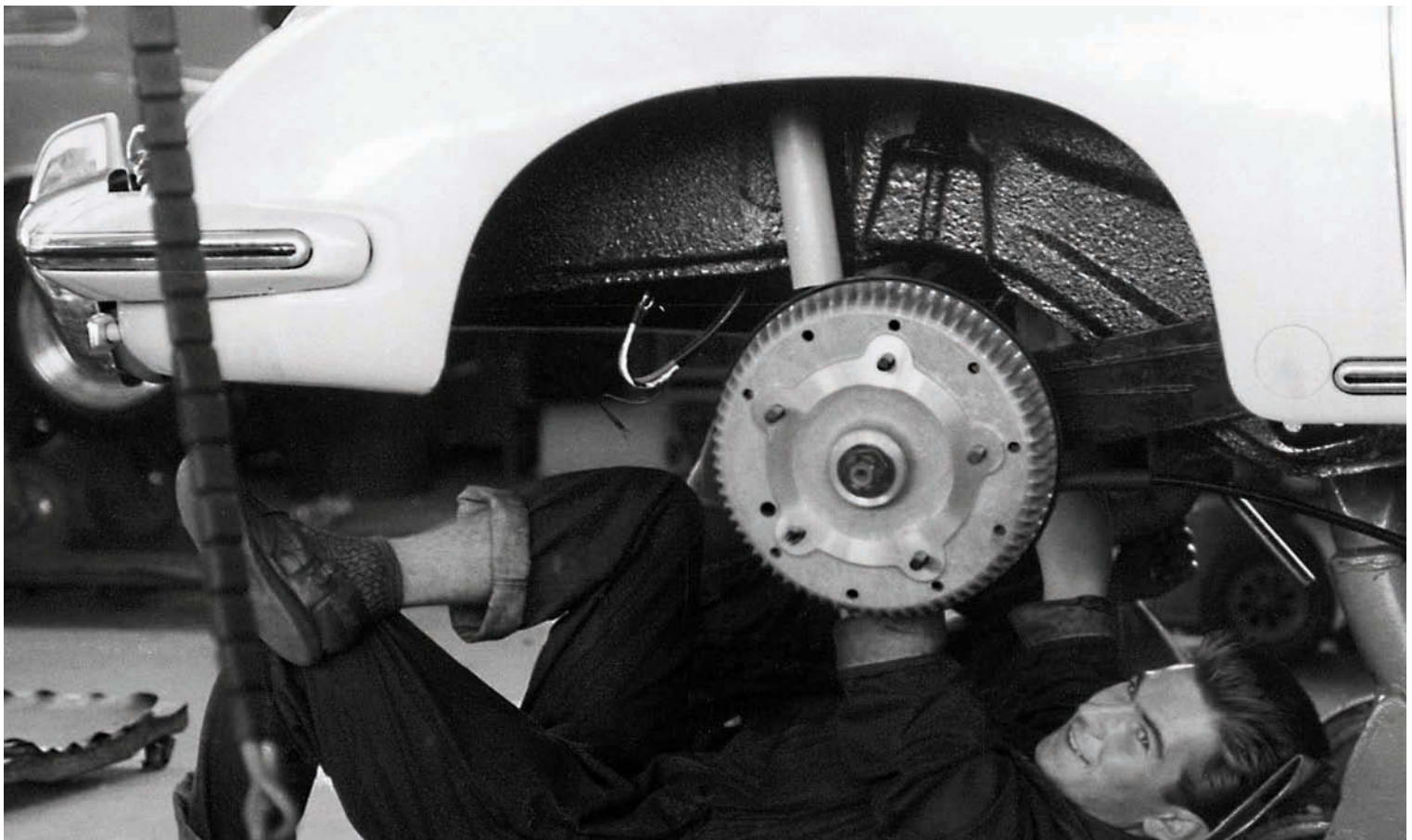



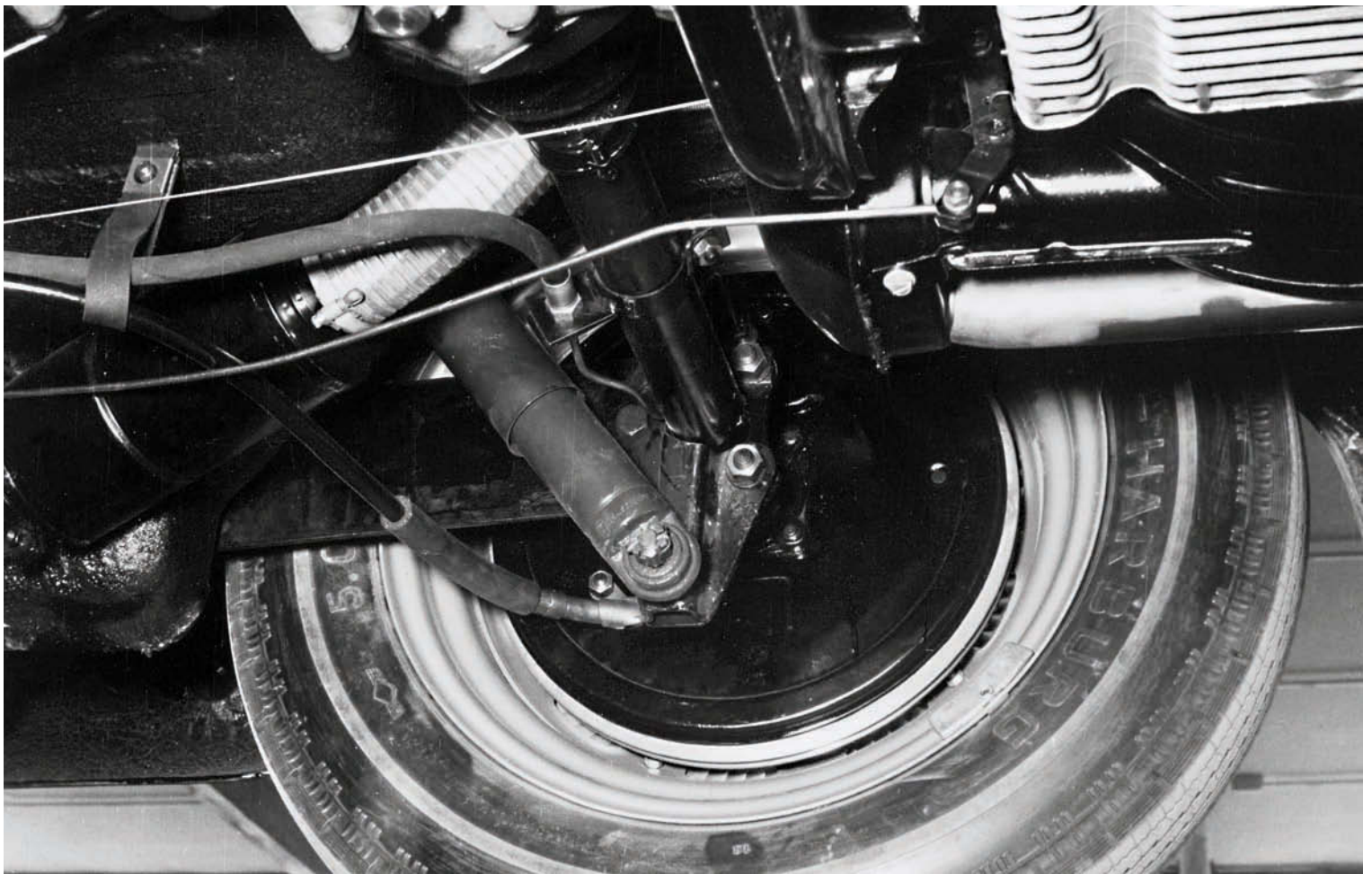

the axle, the other connected to a bell-crank, gripped the disc using a copper-faced pad as the friction material.

Lanchester's disc brake was a promising start but the idea was more or less ignored for four decades. It seems that the American manufacturer Crosley was the first to adapt a disc brake to a production car, although Chrysler also makes that claim. The difference is that Crosley's was a true disc brake as we know it today, whereas the Chrysler design consisted of a pair of metal discs being pushed against the inside of a drum.

Citroën is credited with the honour in Europe, as it built a small number of road cars – more correctly DS prototypes – in 1955 with disc brakes, but Austin-Healey sold 50 of its race-ready 100S with discs that year, too. Then Triumph fielded a team of disc-brake-equipped TR2s in the ill-fated 1955 Le Mans 24-hours ahead of the launch of the similarly-braked TR3 production model in October that year.

So, the 'disc brake race' was won by Lanchester in 1902, followed by Crosley in 1949, Jaguar in 1952, and then Citroën, Triumph and Austin-Healey in 1955. But Porsche was nowhere to be seen...

Porsche could be a stubborn company, and tended to rely on tried and tested ideas in certain areas. Porsche was innovative in many ways but when it came to brakes, there was a reluctance to make changes for change's sake. The large aluminium drum brakes used on all Porsches, both road and track, since late in 1952 were deemed perfectly adequate. True, Porsche race cars were lighter than most rival machines, placing less of a strain on the brakes, but surely there had to be a benefit to using this new-fangled disc brake technology?

In 1958, Porsche finally embarked on a new project, Type 695 (not to be confused with the later pre-911 prototype of the same title), the aim of which was to develop a disc brake for use on both road and competition models. Much of the research was

carried out by Porsche's own engineers, but they also welcomed input from Britain's Dunlop, one of the leading suppliers of disc brake systems.

Birmingham-based Dunlop provided Porsche with a complete package of wheels, brakes and tyres, much as they had for Jaguar on the Le Mans-winning C- and D-types. Porsche, meanwhile, had been developing its own set-up, which was significantly different to the Dunlop design. Dunlop's was relatively conventional in layout, with a cast-iron disc gripped by

a hydraulically-operated caliper located at the outer edge of the disc. Porsche's was something very different, which we will come to in a moment.

To put the new Dunlop-style brakes to the test,

it was decided to install them on a 356 Carrera coupé entered in the 1959 Nürburgring 1000km race, to be driven by Herbert Linge and Baron Pucci. The car ran in practice with Porsche's own disc brakes, but these were swapped for the race to a set of Dunlop discs. Porsche's Klaus von Rucker is said to have found the Dunlop brakes to be perfectly acceptable in testing, but once subjected to race conditions, everything changed.

'Unfortunately,' recalled von Rucker, 'the result was very bad. After 27 laps, the car had to be called into the pits to have the brake pads replaced, the originals being worn down to the metal backing.' This was an unacceptably high rate of wear and the decision was made to continue using the tried and tested drum brakes, 'at least for the time being. They (disc brakes) will not be used on production cars unless our own version of the disc brake produces better results,' said von Rucker.

Porsche's own design of brake was certainly interesting. Rather than mounting the caliper outside the disc, which itself was normally bolted to the centre of the wheel hub, the Porsche

*Above: From below it is possible to get a clear view of how big the 356 drum brakes were – they were the largest drums that could still be squeezed inside the 15in steel wheel*

## “DUNLOP PROVIDED PORSCHE WITH A COMPLETE PACKAGE”



# CSP DISC BRAKE SYSTEM



AUTOBAHN  APPROVED

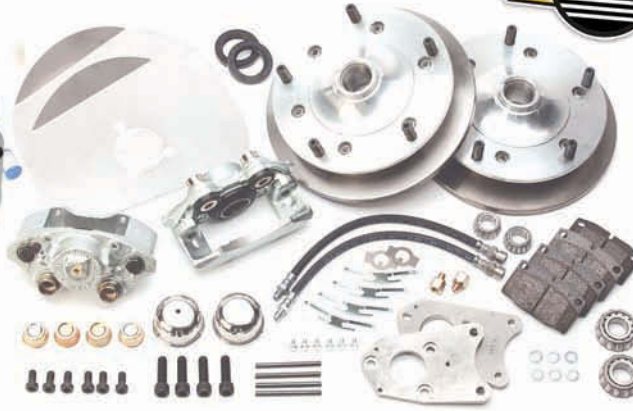

## IN-HOUSE DEVELOPED AND MANUFACTURED

Since 1997 the CSP disc brake system is available and has proven its tremendous reliability a thousand times. It is TÜV approved, build to a quality standard of its own and comes with all hardware necessary for a correct installation on your Porsche 356. There is no need to modify or alter the spindles, which makes it easy to swap back to the original drum brakes if requested.

QUALITY PARTS FOR QUALITY CARS  
[WWW.CSP-SHOP.COM](http://WWW.CSP-SHOP.COM)

## PATRICK MOTORSPORTS

PORSCHE® & MID-ENGINE PERFORMANCE SPECIALISTS SINCE 1989

### FLYWHEEL & CLUTCH PACKAGES

- OEM / RS / RSR Lightweight / Conversions
- Precision Computer Balancing Standard with all packages!



### YOUR CONVERSION EXPERTS!

	<b>OIL SYSTEMS</b> 	
<b>TRANSAXLE SPECIALISTS</b> 		<b>ENGINE CONVERSIONS</b> 
	<b>TWIN PLUG IGNITION</b> 	

602-244-0911 patrickmotorsports.com  
 Phoenix, AZ USA - Daily Worldwide Shipping

©2017 : All Rights Reserved : JE Patrick Motorsports, LTD. - SSN.0910 | PORSCHE® is a registered trademark of Dr. Ing. h.c. F. Porsche AG. These products are not officially approved by PORSCHE®.



**We don't restore Fuchs® rims...  
 We save them!**

30 years of expertise : Straightening, soldering, polishing, anodizing, dip painting... we do it all, so your rims will look like they did when they came out of the factory... 50 years ago

ART WHEELS - Strasbourg - France - info@art-wheels.eu  
[www.art-wheels.eu](http://www.art-wheels.eu) - Tel +33 981 961 992

**ART wheels** 



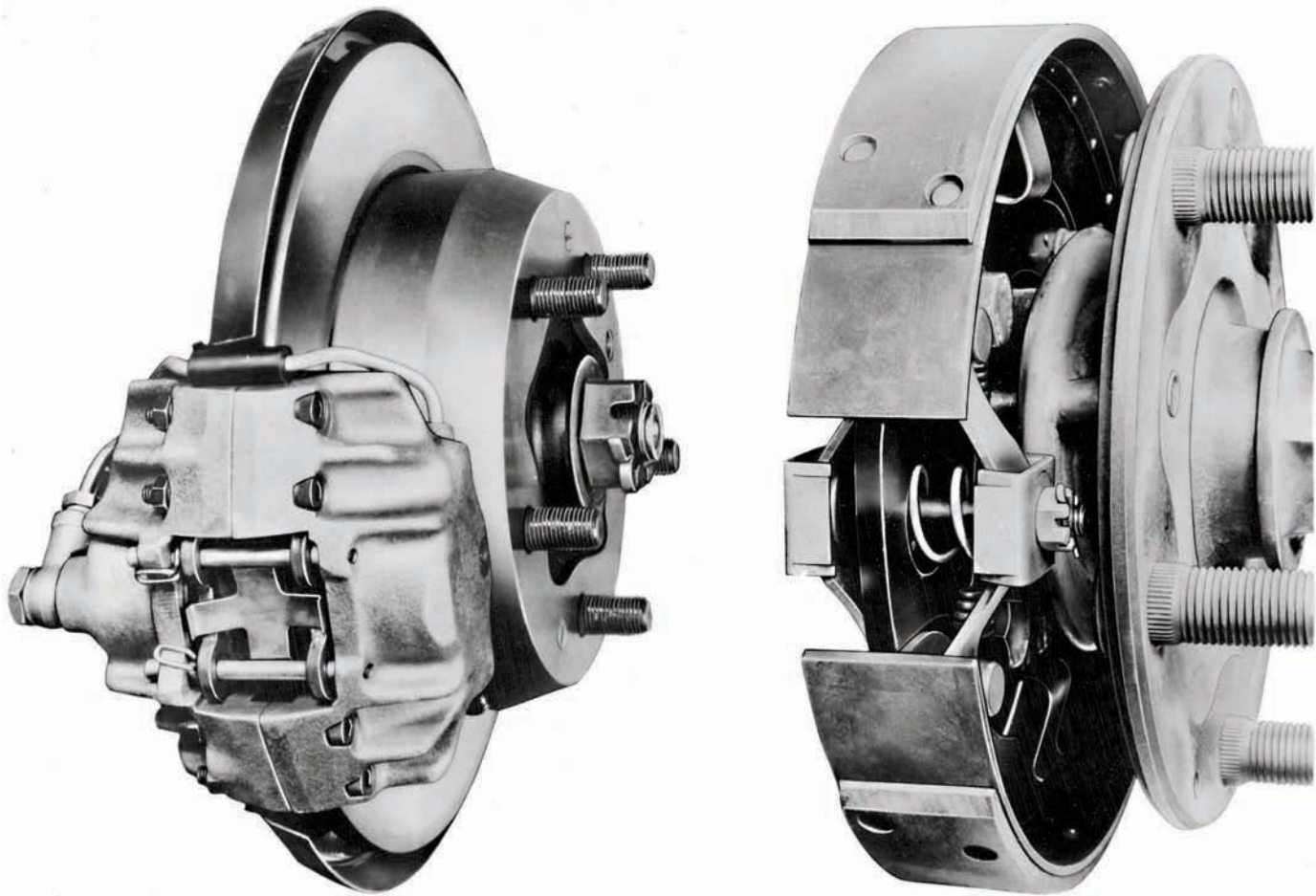

set-up mounted the caliper inside the disc, which was bolted along its outer edge to the wheel hub – this design capitalised on the ‘wide-five’ VW-derived bolt-pattern which Porsche had used since its earliest days. This layout reflected current aircraft braking technology and had a number of advantages, not the least being that the hubs could be made far lighter, thus reducing unsprung weight.

This layout (referred to as ‘annular’ disc brakes) meant that the disc could be of a far larger diameter than the Dunlop design, the Porsche disc measuring 11.8ins (265mm) in diameter. This had the benefit of increasing the friction area, at the same time increasing the amount of leverage the caliper could exert. The brake caliper itself was cast from aluminium, helping to further reduce unsprung weight – Dunlop’s calipers were of much heavier cast-iron.

In terms of servicing the brakes, the Porsche design was streets ahead, too, as the pads could be removed quickly through the spokes of the hub. And the parking brake – always the bugbear on four-wheel disc brake systems – consisted of a two expanding shoes which acted on the inside of each rear disc.

For a company so obsessed with light weight and fine handling, the Porsche-designed discs really made their mark: they were almost 7kg lighter than the equivalent Dunlop units, not only reducing unsprung weight for better handling, but also cutting down on the flywheel effect of the revolving wheel/brake assembly which a braking system has to overcome. It was a natural choice for the current race car programme, and was adopted for the new 356 Carrera 2 launched in 1962.

## “THE ANNULAR DISC BRAKES WERE TOO SPECIALIST...”

However, the annular brakes did come in for comment – if not exactly outright criticism – from some members of the press, who pointed out that they needed to be warmed up before becoming fully effective, unlike drums which tended to be most efficient when cold. However, this trait was a distinct benefit as far as racing applications were concerned, as the disc-braked cars tended to last the distance better than earlier drum-braked models. Indeed, a Carrera equipped with annular brakes competed in the 1960 Nürburgring 1000km and completed the event without requiring a change of disc pads, unlike the previous year. Score one to Porsche over Dunlop...

However, there was about to be a major sea change at

Porsche, for the days of drum-braking were all but over. It was to be an historic moment, for the drum brakes, and the annular disc brakes, all relied on the use of the VW-derived 205mm PCD wheel bolt pattern. However, the annular brakes were too specialist for mass production, and because of the unusual bolt pattern, they could not be readily used on other, non-

Porsche products. On the other hand, Dunlop’s system, as manufactured by ATE, could be used in multiple applications, across many manufacturers. Porsche had marched itself into a dead-end as far as further development was concerned.

By 1962, Porsche’s principle advocate of the annular brake system, Klaus von Rucker, had left the company. Porsche had also decided to withdraw from Grand Prix racing, where the discs had proved to be particularly effective, all efforts now being concentrated on sports car competition which was deemed to be of far better value with regard to sales promotion. Porsche turned to ATE once again who designed a Dunlop-style disc brake (small-diameter disc with the caliper

*Above: With the arrival of the 356C in August 1963 came the adoption by Porsche of the ATE-designed disc brake assembly. This design remained in production virtually unchanged with the arrival of the new 901/911*





*Above left and right: Porsche's own annular disc brake (the caliper is mounted inside the disc) was effective but ultimately doomed to failure as it could only be used with wheels using the 'wide-five' bolt pattern*

*Below left: 1967 911S front brake is virtually identical to that of the 356C with the exception of the vented discs to aid cooling*

*Below right: 550 Spyder brakes featured wide drums with aggressive finning*

mounted at the outer edge) that would meet the demands of the German sports car manufacturer.

The result was a solid cast-iron disc on which acted a cast-iron caliper containing two pistons – the costly to produce annular brakes featured four-piston calipers – designed to automatically align the pads and return them to the correct position after use. The other unique feature on the Porsche-developed brakes was the inclusion of the drum-type handbrake at the rear.

This became commonplace on many cars over the years, but was unique to Porsche at the time. To incorporate the drum brake, the rear discs were made slightly larger in diameter than those at the front, 285mm compared to 274mm. This change in brake design required the use of a new wheel with a smaller PCD – 130mm compared to the original 205mm, but still with five studs.

The new brakes were used first on the incoming 356C models, launched in 1963, and were so good that they continued in production, virtually unchanged, when the new 901 (which became the 911) was released. In fact, the only

difference between the 356C and 901/911 disc brakes was a slight increase in diameter of the front discs (to 282mm) on the new model.

The cast-iron caliper/solid disc combination remained the norm until the launch of the high-performance 911S in 1966, this becoming the first 911 to feature ventilated discs and aluminium calipers. Since then, with the exception of the exotic PCCB (Porsche Ceramic Composite Brakes), Porsche braking systems have largely followed the same path, with increasingly-larger ventilated cast-iron discs 'grabbed' by increasingly-larger aluminium calipers.

The ultimate incarnation of this was the 917-developed vented and drilled discs with large multi-piston calipers that found their way onto Porsche's mighty 930 road cars. However, as impressive as these brakes are, they are essentially little more than a refinement of early-1900s thinking backed up by 1950s technology, the major improvements having been made in three areas: materials, servo-assistance and anti-lock braking systems. And tyre technology – mustn't forget the role played by tyres in braking. But that's another topic for another day... **CP**

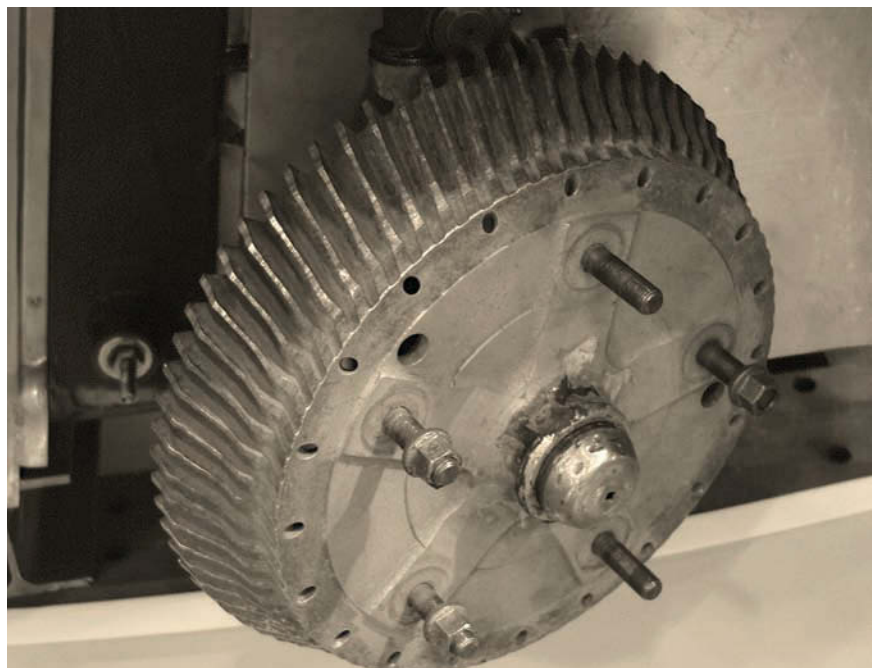
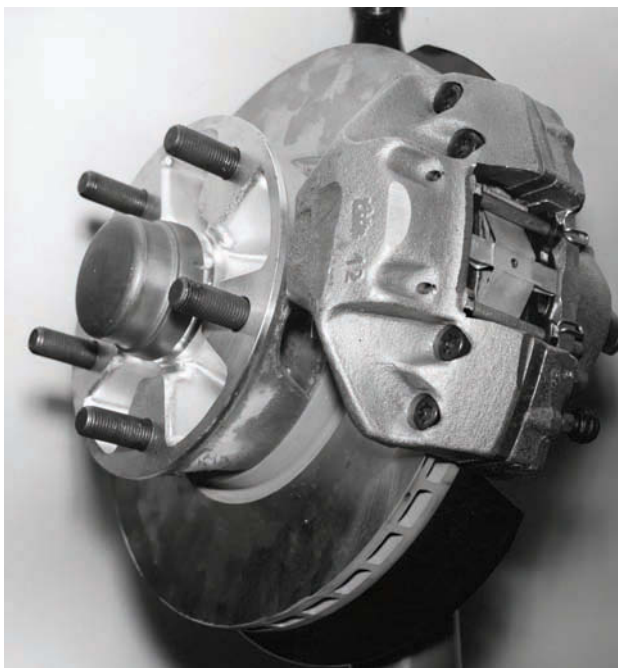



# GET A COOL OUTLAW TSHIRT!



**WWW.CAR-BONE.PL/SHOP**  
**OR CALL US: +48429422115**

REAL AIR FILTER SOLEX 40 PII AIR CLEANER



356,912  
SEBRING STYLE  
EXHAUST SYSTEMS



MERGE COMP 904  
EXHAUST SYSTEM  
FOR EARLY 911



NO TIP HOLE REAR LEFT BUMPER  
911, 911L AND 911S (1965-68)



NO TIP HOLE REAR LEFT BUMPER  
911T, 911E AND 911S (1969-73)



**VINTAGE SPEED**  
ACE OF AIRCOOLED

shop.vintagespeed.com.tw  
Email Order: shop@vintagespeed.com.tw

16, 25 th Rd. Taichung IND. Park Taichung City,  
40850 TAIWAN

# REAP

REAP AUTOMOTIVE DESIGN



Colour coded gauges for Porsche 911 to 997 and Boxster, Cayman and Cayenne. All colours available including Custom matching. Our product is the best available and was OEM on UK spec 993's. Full fitting service on site now available by appointment only. Restoration and repair are also available. Flaking 964 gauges are restored to OEM specification.



Prices: Porsche 911 > 90	£275.00
Porsche 964 - 993	£250.00
Porsche 996 - 997	£250.00
Porsche Boxster / Cayman	£225.00
Porsche Cayenne	£250.00
Fitting service	£50.00
Import & export conversions from	£100.00
Repair, Recalibration, Restoration	P.O.A.
Prices exclude VAT	

[www.reapautomotivedesign.com](http://www.reapautomotivedesign.com)

TEL: 020 8863 2305

NEW  
WEB SITE



## Early 911S Registry

The Early 911S Registry is dedicated to the appreciation of Porsche 911S cars and all Early 911s built during the model years 1967 through 1973.



Join the  
**Early 911S Registry**  
and you will receive  
**ESSES**  
our quarterly  
publication.

For online membership:

[www.early911sregistry.org](http://www.early911sregistry.org)





# WWW.PRS356.CO.UK

## PARTS · RESTORATION · SERVICE

LARGEST SELECTION OF 356 PARTS IN THE UK!

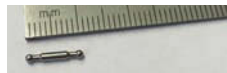

### 356BC and 911 - Indicator "Headlight Flash" Repair Pin

Newly manufactured parts to repair those original indicator stalks that have broken and gone floppy after years of wear and tear  
Price £19-80 inc VAT



### Pre "A" Demister Seal

Newly manufactured rubber seal that goes between the dash and the windscreen de-mister tube on a Pre 'A'  
Price £40-20 inc VAT



### Twin Brake Reservoir bracket

Ideal for twin master cylinder conversion on 356 or early 912 and 911. Designed to hold standard 356C reservoir  
Price £250 + VAT



### Red and Amber Teardrop Tail Light Lenses

Newly manufactured reversed red/amber lenses for greater clearance when converting stop/tail light setups. Standard issue in Italy, Australia and New Zealand  
Price £24-00 inc VAT



### 356A Horn Mount

Horn mounts with hollow hexagonal base to fit 356A  
Price £54-00 inc VAT



CALL 0044 1277 630099

Dunlop Garage, London Road, Billericay, Essex, CM12 9HP

## 911



**911 1974 Coupe**, left-hand drive, 2.7 CIS, first of the impact bumper, Certificate of Authenticity, black with black trim, history, handbook and documentation, £32,000. Tel: 01704 880728. Email: hmcleod2011@hotmail.co.uk. C51/018

**911 Carrera 3.2**, 62,000 miles, black with black leather interior, 12 months' MOT, lots of history and documentation, same owner for last 18 years, a very original car with overall good bodywork but does need some minor work to the body (photos available), £42,000, the car is an original right hand drive/UK registered car and located in the UK. Tel: 0041 7874 54223. Email: croftsp@gmail.com. C51/019

## 1975 911S Targa resto project

requiring new floors, Targa roof panel and engine are missing, 915 gearbox and four original 6J x 15" Fuchs wheels are included, US spec LHD original Copper Brown metallic, perfect stainless steel Targa roll hoop, all original glass, not chipped or cracked, full interior including all five dashboard gauges, speedo. In need of welding and full restoration, £12,500 ono. Tel: 07939 248355. Email: alextowne1@gmail.com (Warks). C51/027

## 912

# PORSCHE 912

Sales  
Service  
Spares

revival-cars.com  
07768 791802  
WEST LONDON

## 914



**914/6**, year 1970, GT conversion with flares, 7" and 8" original Fuchs wheels, front oil cooler, original body and rear susp, arms reinforcements (original GT spec), original GT style bucket seats, detachable rollbar as with factory GT cars, VIN number: 9140432101. Currently fitted with a 993 3.6L engine on carbs, can be sold with the documented engine, 120,000 Euros. Tel: João Matos, +351 938 139787. Email: jpmatos59@gmail.com. C51/017

## Parts



**Porsche 911 3.2 rear exhaust** to fit 1984-1989 model, good condition, £90. Tel: 07932 605497. Email: alfdixon@gmail.com (Cheshire). C51/028



**CURRENTLY OFFERED AT**  
**PATRICK**  
**MOTORSPORTS**  
**917 LMK Gulf**



**1969 911 S**



**916 Tribute**



**1966 912 3 Gauge**  
 2015 PCA WERKS REUNION WINNER



**914-6 GT Vintage Racer**  
 2016 PCA WERKS REUNION WINNER



**See these and other cars for sale at:**  
[Facebook.com/patrickmotorsports](https://www.facebook.com/patrickmotorsports)  
**602.244.0911**  
[sales@patrickmotorsports.com](mailto:sales@patrickmotorsports.com)

**Porsche 911 Turbo alloys**, 17" alloy wheels to fit 1984-1989 model, £300. Tel: 07932 605497. Email: alfdixon@gmail.com (Cheshire). C51/020  
**1977 Porsche 911 parts for sale**, 911 parts, bonnet, boot lid, bumpers, various instruments/sundries. Tel: 07879 466740. Email: keith@seatown.co.uk. C51/012



**Porsche 911 3.2 flag mirrors**, Guards Red, 1984-1989 model, £50. Tel: 07932 605497. Email: alfdixon@gmail.com (Northwich). C51/008



**Restored Porsche Fuchs 1973 flat six**, rare set of genuine 1973 Porsche Fuchs flat 6, fully restored, offers in excess of £3000, more pics and serial numbers on request. Tel: 07768 860433. Email: lee@mkflooring.com (Bucks). C51/007



**Porsche 911 parts for sale**, rear spoiler off '75 2.7, £400; complete black carpet set, £50; rear lower quarter panels off SC, £40 each; rear lower quarter panel off 2.7, £30, needs work; front smile, £35; front roll bar, £50; s/s exhaust system, £350; 1 s/s heat exchanger, £250; front steering cross member, early steel, £60; pair wishbones, rusty but ok, £50pr; ono on all items plus other items available, call or email for details. Tel: 07903 783586. Email: d.m.stllr@ntlworld.com. C51/026



**911 2.7/SC spares**, s/steel exhaust system (Langford), £250; s/s heat exchanger, £200; rear lower quarter panels off SC, good condition, £40 each; 1 no O/S rear lower quarter panel, needs work, £30; frt smile, good condition, £35; frt roll bar, £50; new spring plate cover, £35; URO door seal, £25; frt fog lights, £250; ally instrument bezels, £90; alloy window switch covers, £50; few other bits available, open to offers on all items. Tel: 07903 783586. Email: d.m.stllr@ntlworld.com. C51/009

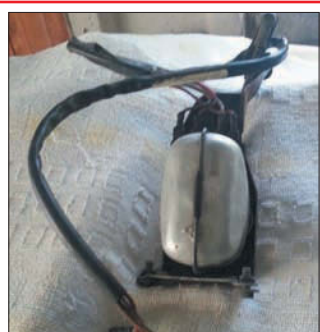

**Porsche 911 rear window wiper motor**, to fit model 1984-1989, £60. Tel: 07932 605497. Email: alfdixon@gmail.com (Cheshire). C51/010

## Miscellaneous

**Registration for sale**, 'JJI 9115' number on retention, £2000. Tel: 07810 058297. Email: s-blakeley@sky.com. C51/004

**911 & Porsche World** back issues no 1 to 200 consecutive, (1 to 36 are bound), 214 to 261, all in excellent condition, reluctant sale of my collection, offers for all preferred. Can be collected from Shrewsbury SY4 or mid Wales SY25 areas, any questions please ask. Tel: 07494 209144. Email: davidwalters2009@hormail.co.uk (Shropshire). C51/013

**Clearout by former Porsche 356A racer**, see Keith Seume Oct 2002 'The Money Pit' article in 911 & Porsche World, clears barn of Porsche auto jumble and memorabilia. Email wayne.hardman@btconnect.com for extensive list of items available. C51/011

**Registration plate 'LSV 944'**, registration plate 'LSV 944', £2250, open to offers. Tel: 07944 539205. Email: richard.cooper@homecall.co.uk. C51/021

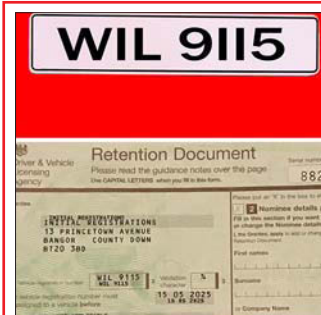

**'WIL 9115' on a retention certificate**, valid until 2025, I can arrange the transfer or you can have the certificate for transfer in the future, £1995 with all fees paid, nothing extra to pay. Tel: 07882 256913. Email: merv55@hotmail.com. C51/001



**'POR 911L' registration number**, would suit any 911 (August 1972 or later), held on certificate of entitlement (V750), no further fees to pay, easy transfer, you are buying the registration number and not the car in the advert, £6500. Tel: 07926 035523. Email: philipjelinek1960@gmail.com. C51/005



**Boxster plate 'BOX 80Y' (BOX BOY)**, great plate for Boxster, £4000. Tel: 07767818983. Email: steve@hayes-net.com. C51/002

**Krebsfer engine cradle and stand**, genuine Krebsfer engine cradle mounted on custom made steel stand, cradle can be unbolted for bench mounting. Previously used for rebuilding Porsche and VW air cooled engines, £69, I can email photos. Tel: 01590 670813. Email: robroberts7@hotmail.com (Lymington). C51/014

**Number plate 'VGS 911S' for sale**, nice Porsche number plate 'VGS 911S', £3000, sensible offers invited. Tel: 07768 938967. Email: thedjrobinson@icloud.com. C51/003

**Porsche repro garage wall signs**, 2ft repro garage wall sign for display on your garage or showroom wall, £50, I also have the same in 3ft x 28-inch. Tel: 07704 466754. Email: smithbarrington@gmail.com (Leics). C51/016

**Classic FX**  
 Classic Porsche Trimming  
 356 - 911 - 912 - 914 - 928 - 964  
 Trim and leather to OEM specification. Full or part car retrim, based in Surrey UK. Manufacture and supply of carpets, seat covers and door cards. A personal and detailed yet competitive service.  
 Call Garry on  
 0755 100 3000  
[www.classicfx.net](http://www.classicfx.net) [garry@classicfx.net](mailto:garry@classicfx.net) [www.facebook.com/classicfx](https://www.facebook.com/classicfx)



**PORSCHE RELATED CHERISHED REGISTRATION NUMBERS**

911 ADS	RED 911H
REG 911E	911 HDL
S911 LER	911 WVS
TON 997X	911 SCR
POR 997T	911 FEG
POR 911K	911 MSD
1974 RS	CAR232A
993 POR	930 FF
993 RUF	XXX 911C
X993 POR	991 PD
VNZ 911	911 RWS
964 MC	B911 RSR
964 GC	A993 XXX
RSR 911K	D911 POR
RSR 911T	E944 POR
RUF 911T	1 YRS
WBZ 911	

All on retention certificates for immediate transfer

PCGB MEMBER TEL: 07730 007694  
EMAIL: erha300@aol.com

**Porsche 959 cherished number**, cherished number for your Porsche 959, '11L 959', £3750. Tel: 07988 657326. Email: leigh.weaver@btinternet.com. C51/006

**Porsche Speedster manual**, the evolution of Porsche's lightweight sports car, 1947 to 1994, covering 356, 964 and 911 Speedsters, written by Dr Michel Thiriar, hard back containing 218 pages with full details and illustrations. Email: petestans@yahoo.co.uk. C51/022

**We buy Porsche parts and Historic Porsche**

**We** buy all **Porsche competition parts** dating from 1950 to 1998. Body, engine, mechanical parts, etc. We buy **Porsche needing restoration or incomplete cars** : Models : 356 Gmund - 356 Carrera - 550 - 911 (1964) - 911 R - ST - 2.7RS - 2.8RSR - 3.0RS - 3.0RSR - 904 - 906 - 907 - 908 - 909 - 910 - 917.

**Please contact us by email :**  
[contact@raceparts9.com](mailto:contact@raceparts9.com) or [contact@racecars9.com](mailto:contact@racecars9.com)

**Wanted**

**Wanted early 911 literature**, early 911 literature wanted (especially 2.4), eg driver's hand book, document wallet, sales brochure, anything of the period, service records etc. Tel: 07545 234505. Email: richard@uplandsorchard.co.uk (Herefordshire). C51/023

**Wanted Classic Porsche magazines**, numbers 1, 8, 9, 11, 12 and 15, will pay fair price and postage. Tel: Brian, 07770 962354. C51/024

**ADVERTISING INDEX**

356 Panels	28	Mittelmotor	79
Art Restoration	91	Parr	6, 99
Car Bone	94	Patrick Motorsports	91
Classic FX	96	Porsche Cars GB (Winter Tyres)	7
Classic Retrofit	44	Reap Automotive Design	94
Club Autosport	85	Restoration Design Europe	23
Coco Mats	15	RJJ Freight	85
Custom & Speed Parts	91	Roger Bray Restoration	20
Dansk	100	Rose Passion	63
DC Classics	20	RS911	44
D'Eser	20	Sierra Madre Collection	29
Design 911	21	Specialist Cars of Malton	45
Early 911S	75	Sportwagen Eckert	69
Early 911S Registry	94	Stoddard Parts	25
Elephant Racing	55	Tandler Precision	6
Export 56	37	The Blockley Tyre Company	53
FVD	2	The Porscheshop	28
Greatworth Classics	85	Vintage Speed	94
Heritage Parts Centre	27	Zims Autotechnik	85
Historics at Brooklands	19		
Jaz Porsche	79	<b>Classifieds</b>	<b>95-97</b>
Joma Parts	28	Eisenbrandt	
Karmann Konnection	78	Eric Hall	
Lakewell Porsche Interiors	85	Patrick Motorsports	
LN Engineering	44	PR Services	
Lüfteknik	78	Revival Cars	

**QUALITY WITH WARRANTY**

**NUMBER 1 WORLDWIDE FOR**

**MFI MECHANICAL FUEL INJECTION**

High-end measurement and repair stations  
Complete repairs correspond to the quality and function of the original new factory state

**PERFECTION FOR YOUR CLASSIC CAR**

**EISENBRANDT RACING AND SPORTS CARS**

special safety-box

QUALITY MADE IN GERMANY

+49 (0) 681 - 959 0 911  
[WWW.EISENBRANDT.EU](http://WWW.EISENBRANDT.EU)

**YOU CAN UPLOAD YOUR PRIVATE ADVERT AT: [www.classicporschemag.co.uk](http://www.classicporschemag.co.uk) OR YOU CAN EMAIL: [classifieds@chpltd.com](mailto:classifieds@chpltd.com)**

**PRIVATE ADVERTS ARE FREE! YOU MAY INCLUDE A PHOTOGRAPH AND UP TO 400 CHARACTERS OF TEXT.**

Copy can be submitted online or by email, fax (+44 (0)1883 740361) or post, to:  
**Classic Porsche Private Classifieds, CHP, 1 The Alma Building, Brewerstreet Dairy Business Park, Brewer Street, Bletchingley, Surrey RH1 4QP, UK.**  
Deadline for inclusion in issue 52 is 22 February (on sale 15 March).



# SUBSCRIBE & SAVE!

**PAY JUST £3.83\* PER ISSUE INSTEAD OF THE £4.95 NEWSSTAND PRICE**

GUARANTEE YOUR COPY OF *CLASSIC PORSCHE*, DELIVERED DIRECT FROM THE PRINTER TO YOUR DOOR - BEFORE THE OFFICIAL ON-SALE DATE!

## CALL +44 (0)1883 731150

OR SUBSCRIBE ONLINE AT  
**CLASSICPORSCHEMAG.COM**

\*BASED ON UK 18 ISSUE SUBSCRIPTION



	1 YEAR (NINE ISSUES)	2 YEARS (18 ISSUES)
UK	£39.50	£69.00
EUROPE	£54.75	£79.50
REST OF WORLD	£69.50	£118.50





## VALVE-CONTROLLED EXHAUST SYSTEMS FOR YOUR CLASSIC PORSCHE

Introducing the new **CARGRAPHIC** sport exhaust systems with innovative integrated exhaust flaps for the **air cooled Porsche**.

Developed for maximum flow and made from T-304L "lightweight" stainless steel for weight reduction, the system also adds reduced back pressure and temperature for added performance, alongside the uniquely designed pressureless valve system for an enhanced soundtrack.

- // Reduced Back Pressure
- // Reduced Temperature
- // Maximised Performance
- // Enhanced Sound
- // Weight Reduction

**AVAILABLE NOW** AS TWO HIGH PERFORMANCE MODULAR SYSTEMS FOR YOUR AIR COOLED CLASSIC PORSCHE 911



## THE PERFECT PARTNERSHIP FOR YOUR PORSCHE

With over 30 years experience, PARR is the UK's leading Porsche specialists and as the official importer of CARGRAPHIC tuning products, we offer a wide range of parts for your Porsche and other marques. From simple tuning and upgrades to bespoke modifications, performance engineering to custom styling options, we have the solution to suit you.

**PARR**  
Specialists In Porsche  
5 The Faraday Centre,  
Faraday Road, Crawley,  
West Sussex RH10 9PX  
United Kingdom

**CARGRAPHIC THOMAS SCHNARR**  
Tuning Programs For Prestige  
And Sportscars  
Wieslauterstrasse 20,  
D-76829 Landau, Germany





**Next time your Porsche® is being serviced**



## **Ask them to use Dansk parts**

**Danish quality**

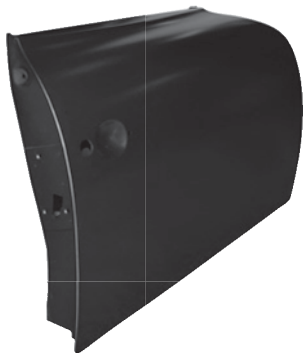

**Dansk no. 571041 (JP no. 1680900770)**  
**Door, complete, left\***  
**Fits: 356 A/B/C Coupé (1.6) 55-65**  
**\*Right side also available**



**Dansk no. 571100-8 (JP no. 1615600400)**  
**Fuel tank, OE version, 52 L**  
**Fits: 365 B T6/C (1.6) 61-65**



**Dansk no. 571000-8 (JP no. 1615600300)**  
**Fuel tank, OE version, 50 L**  
**Fits: 356 /A/B T5 (1.1-1.6) 50-61**

**Dansk no. 571210**  
**(JP no. 1680101100)**  
**Bonnet**  
**Fits: 356 C (1.6) 64-65**

**Dansk no. 571110**  
**(JP no. 1680100900)**  
**Bonnet**  
**Fits: 356 B T6 (1.6) 61-63**



*Also available in lightweight aluminum (571210ALU + 571110ALU)*

**Why compromise when you can have the best...**

**♦ Dansk®**

JP Group a/s - Hjulmagervej 2 - DK-8800 Viborg - Tel. +45 8661 5100 - Fax +45 8661 2230  
[www.jpgroupclassic.com](http://www.jpgroupclassic.com) - [classic@jpgroup.dk](mailto:classic@jpgroup.dk)

*Contact us and we will refer you to the nearest distributor*