

Leading-Edge Motorsport Technology Since 1990

# Racecar engineering™

November 2018 • Vol 28 No 11 • [www.racecar-engineering.com](http://www.racecar-engineering.com) • UK £5.95 • US \$14.50

## Splash and dash

**WRC teams  
reveal their  
tech secrets**



**Formula E 2018/19**  
The radical racecar that's  
set to shake up the FE field



**Lamborghini GT3**  
Up close and personal with  
the new Huracan GT racer



**Williams FW41**  
Why the once great team's  
2018 car has failed to deliver



# XRP ProPLUS® Reusable Hose Ends

The evolution in **FLUID HORSEPOWER™**



 Like us on  
[Facebook.com/XRPinc](https://www.facebook.com/XRPinc)

 Follow us on  
Instagram  
[@XRPricing](https://www.instagram.com/XRPricing)

Log on to  
[www.xrp.com](http://www.xrp.com)  
anytime for catalog downloads,  
new product updates  
and tech tips.

# **XRP**

**THE XTREME IN RACECAR PLUMBING**

**US** XRP, Inc. [sales@xrp.com](mailto:sales@xrp.com) tel 562 861 4765 fax 562 861 5503  
**EU** PROTEC FUEL SYSTEMS LTD. [info@protecfuelpumps.com](mailto:info@protecfuelpumps.com) tel 44 (0) 121 572 6533

## COVER STORY

- 8 World Rally Championship**  
The WRC's four manufacturer teams talk us through their 2018 tech developments

## COLUMNS

- 5 Ricardo Divila**  
Predicting motorsport's future is an impossible task
- 7 Mike Blanchet**  
Why the F1 driver market is both ruthless and confused

## FEATURES

- 16 Williams FW41**  
What's wrong with the Grove team's 2018 F1 car?
- 24 Formula E Season 5 tech preview**  
New racecar + new race format = new tech challenges
- 29 Cruden simulators**  
Formula E's virtual development tools examined
- 30 Lamborghini Huracan GTE Evo**  
Full details on the comprehensive Lambo GT3 update
- 38 Working in motorsport**  
The jobs that are out there and how you can get them

Street smart: The new version of the Lamborghini Huracan GT3 (p30) is more than just a headturner



## TECHNICAL

- 47 The Consultant**  
Selecting springs and anti roll bars
- 51 Slip angle**  
OptimumG's ground-breaking new tyre load test explained
- 57 Aerobytes**  
Front wing tweaks on a 1983 Tyrrell 012 F1 car
- 60 Formula 1 aerodynamics**  
How F1 has responded to the 2018 CFD restrictions
- 73 Tech explained**  
Designing and building a World Rallycross track
- 80 Danny Nowlan**  
Making a difference with the differential
- 84 Tech update**  
Why McLaren's strategists have their heads in the cloud

## BUSINESS & PEOPLE

- 88 Jean Todt**  
The FIA president on the 2021 F1 regulations
- 94 Business people**  
Electric GT boss quizzed; Don Panoz obituary
- 98 Bump Stop**

Subscribe to *Racecar Engineering* – find the best offers online  
[www.racecar-engineering.com](http://www.racecar-engineering.com)

Contact us with your comments and views on [Facebook.com/RacecarEngineering](https://www.facebook.com/RacecarEngineering)

# 24H MIDDLE EAST SERIES ENDURANCE SERIES

FOR GT-CARS AND PROTOTYPES

3 endurance races within 16 days, for GT and prototype cars,  
perfect opportunity to prepare for 2019 season,  
nearly unlimited testing opportunities on Dubai Autodrome,  
no freight or custom concerns.



DUBAI AUTODROME  
**25-26 JANUARY 2019**  
6 HOURS DUBAI

YAS MARINA  
**1-2 FEBRUARY 2019**  
4 HOURS ABU DHABI

DUBAI AUTODROME  
**7-8 FEBRUARY 2019**  
10 HOURS DUBAI

## SPORTING FORMAT

### EACH WEEKEND

- Free Practice of 30 minutes
- Qualifying of 30 minutes
- Races
  - » 1x Endurance Race with rolling start
- Grid
  - » As per Qualifying results
- Drivers
  - » Two to four drivers
- Cars
  - » GT-cars (GT3, GT-Special, GT4, 991 cup)
  - » GT Retro cars (young timers, pre 2016 GT3, GT2 and GT1)
  - » Prototypes (P2, P3, P4, CN)

**ALL IN PRICE**  
€12.500

### INCLUDING

- » Entry all races
- » Fuel for all events
- » Including freight to Dubai and back from all over the world (sea freight, 2 cars per 40ft container)
- » TV coverage
- » Live timing
- » Race magazine per race
- » Free entry on the grid for guests
- » Working space at Dubai Autodrome in between the races

## CHAMPIONSHIP FOR TEAMS AND DRIVERS

### Middle East Series Endurance Championship

- Points per Race, based on race length

### Middle East Endurance Series Junior Cup

- Special trophy for drivers born 1995 or later

Perfect opportunity to prepare for the 2019 season  
Easy connections - Compact race format - a lot of track time  
No freight or custom concerns, we take care of it  
Creventic can help you with flights, accommodation and other services



DUBAI AUTODROME  
**25-26 JANUARY 2019**

TCR Middle East Sprint Round 1 & 2  
TCR Middle East Endurance Trophy 6H

YAS MARINA  
**1-2 FEBRUARY 2019**

TCR Middle East Sprint Round 3 & 4  
TCR Middle East Endurance Trophy 4H

DUBAI AUTODROME  
**7-8 FEBRUARY 2019**

TCR Middle East Sprint Round 5 & 6  
TCR Middle East Endurance Trophy 10H

## SPORTING FORMAT

### EACH WEEKEND

- Free Practice of 30 minutes
- Qualifying of 30 minutes
- Races
  - » 2x 30 minutes with standing start
  - » 1x Endurance Race with rolling start
- Grid
  - » Race 1: as per qualifying results
  - » Race 2: qualifying top 10 in reverse order
  - » Endurance race: as per qualifying results
- Drivers
  - » One driver for sprint races
  - » Two or three drivers for endurance race
- Cars
  - » All TCR cars homologated by WSC ltd

**ALL IN PRICE**  
€12.500

### Including

- Entry all races (Sprint and endurance)
- » Fuel for all events
- » Including freight to Dubai and back from all over the world (sea freight, 2 cars per 40ft container)
- » TV coverage
- » Live timing
- » Race magazine per race
- » Free entry on the grid for guests
- » Working space at Dubai Autodrome in between the races

## CHAMPIONSHIP FOR TEAMS AND DRIVERS

### TCR Middle East Series Championship

- Qualifying points
- Points per sprint race
- Bonus points for endurance races (10 points for participation)

### TCR Middle East Endurance Trophy

- Points per endurance race, based on race length



# Racing ahead

Why predictions about motorsport's future are doomed to be wide of the mark

Five years ago one of the *Racecar* columns I wrote was a collection of statistics and some conclusions drawn from it. It talked about the direction of the auto industry and motor racing, and basically stated the growth period was over, we had passed peak car and it was all on the way down.

It did get a lot of retorts, mainly from people I knew in the industry, and reproaches about being so pessimistic. My rejoinder was that it is not being pessimistic, just logical, and because racing is something I love, it did concern me that the direction of the sport was being obliged to take did not make me feel comfortable.

The escalating cost of going racing just reflects the general zeitgeist of the world, which is changing at an exponential rate, and anyone who yearns for a return to the golden years ignores two facts; that the golden years were merely gilding, so the rosy outlook is just your memories, a notoriously biased process, and that resistance to change is inherent in the human condition. It applies to the whole of life, not just cars and the racing of them.

There are two solutions. Either adapt to the change and go with the flow, or get into historic racing; better still, go to Goodwood in period dress and pretend you are in the epoch of your choice for a weekend.

## Crystal balls

Long range forecasting does tend to be rather hit and miss. To put it another way, let's assume current practice, technology and social environment can be extrapolated to see what will be coming along. This will constitute around 80 per cent of your data. Throw in another 15 per cent of things you are not sufficiently informed about and that is already out there. The crux of the matter will be the five per cent of game changing new technology, and don't forget the joker of rules and regulations, be it in racing or even in society, which will be brought into the equation by, say, the FIA or by governments, in their respective domains.

What will confuse matters even further is a number of facts not thrown in to the decidedly glum view (from an automobile lover's viewpoint at any rate) of that previous column.

Seven per cent of the total numbers of persons that have been alive since the start of humanity live today. The number of engineers working today is around 15 million. To put this in perspective that is

equivalent to the population of England in 1851, at the start of the industrial revolution. Add in to this at least six million scientists working in the world today and things get really interesting.

Ninety per cent of all the scientists and engineers that have ever lived are alive and working today. If science is growing exponentially, then the major technological advancements and upheavals of the past 200 years are only the tip of the iceberg.

## Weird science

Science and technology have drastically transformed our lives, and is visible in the speeding up of societal change. This revolution has taken place almost entirely in the past 200 years, around one tenth of one per cent of our 200,000 year



**Change is inevitable in all fields of life, particularly technology driven endeavours like motor racing. At Goodwood we can pretend otherwise**

history. Never before have we had so many people whose sole purpose of work is to better understand how the world works. This has far-reaching implications, both good and bad, for the future of humanity. It's difficult to wrap our minds around the blistering pace of innovation that is about to come.

Returning to the future of motor racing, this time we'll look at a relatively short term one. When the previously mentioned column was written, endurance racing looked like being in a renaissance mode, with several manufacturers joining in with apparently long range programmes, while changes in Formula 1 promised a rebirth for the category.

Some nasty numbers kept cropping up, though. For example, the often cited 600 million spectators from the 2008 report decreasing to 425 million in 2014 and then 370 million in 2017. There does seem to be a trend there. Liberty trumpets the increase in social media effects, citing a growth of 55 per cent

in the 2017 period for F1, against the mundane median of around 20 per cent for the other major sports, (seeming to suggest that F1's social media footprint had been neglected for years.)

So how was that column's forecasting? We have in Formula 1 a new owner with plans to change the format, marketing and even the racecars to address the lack of interest shown by the public, evidenced by the dropping viewing figures.

Endurance racing is now trapped in a corner of its own making by tilting the rules to attract manufacturers, most of which have now left the fold, leaving a reduced field, and the correction of the regulations for 2021 repeats the same bias towards attracting manufacturers.

Both major categories are in a major rule

reformulation, which seems to drag on a bit and leaves little time to design and build the new cars for the coming seasons. And spectators numbers are still diminishing.

A quick roundup of the state of racing would be still a depressing one, but hope springs eternal in the human breast. For example, one is aware of climate change, but much of the rest of the world cheerfully files it under 'other subject', as there is a race coming up next weekend and they have no time for moping around.

The best solution would be to get rid of the influence of banks and anybody who is only in racing for financial gain above a reasonable value, thus leaving it to the

practitioners of the sport. That would mean not many spectators, but just possibly a reduction of the cost, but I'm not holding my breath.

One good idea; regulations must come out nice and early, and cater for all the participants in the interest of keeping the sport healthy.

## Money shot

Meanwhile, media conglomerates, banks and the usual vultures must all be purged. A good way to increase audience, in my unbiased opinion, is that they should be hunted for sport. Nothing lethal, you understand, just very, very painful. Any complaints that that is a form of sadism can easily be tempered by the *Lex Talionis*, the law of retaliation, whereby a punishment resembles the offence committed in kind and degree, also known as an 'eye for an eye'. This is further amplified by the number of people that have been impacted by them. 

**Endurance racing is trapped in a corner of its own making by its tilting of the rules to attract manufacturers, most of them having now left**

# EPARTRADE

.com

The Global Platform for the Performance and Racing Industry

JOIN FOR FREE! SIGN UP NOW!

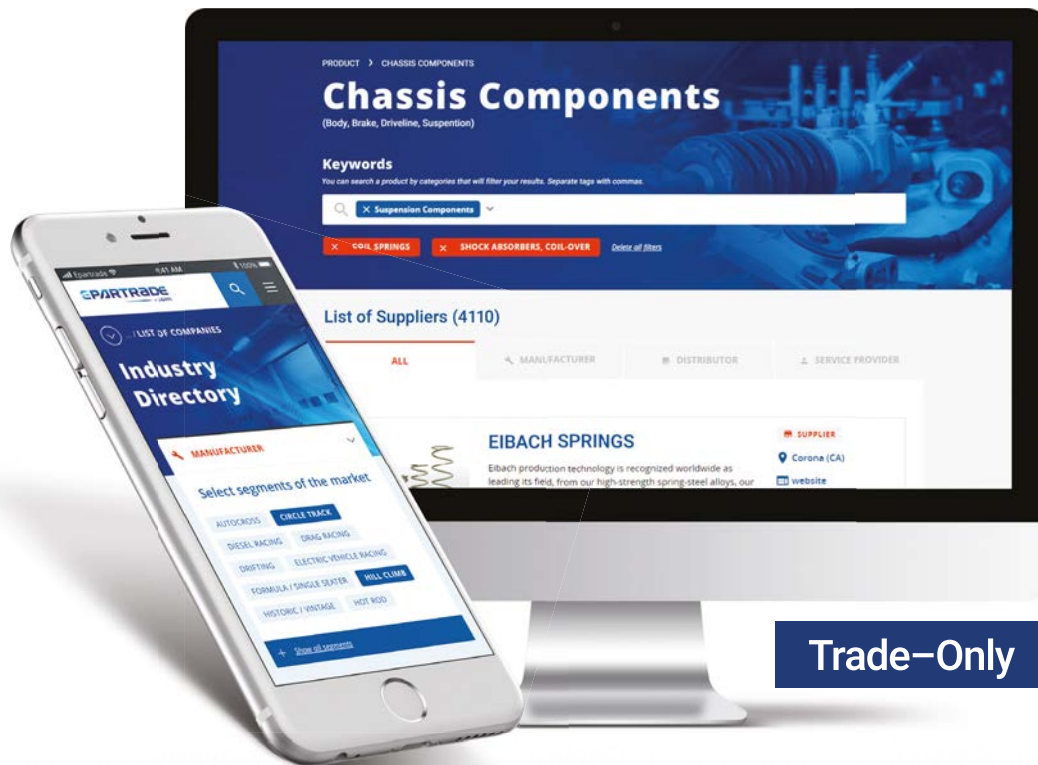

**Connecting Manufacturers  
and Buyers Worldwide, 24/7.**

ONE CLICK AWAY



**WWW.EPARTRADE.COM**

Use EPARTRADE Smart Sourcing Technology to Access Thousands of Racing Suppliers from around the world day or night, like: AEM Performance Electronics, ATL Racing Fuel Cells, Aurora Bearing, Bullet Racing Cams, Calico Coatings, CL Brakes, CP-Carrillo, Dan Olson Racing Products, Daytona Sensors, Dyers Top Rods, Dynojet Research, Eibach Springs, Essex Parts/AP Racing, Ferrea Racing Components, Gandrud Parts Center, GET'M Garage, Hughes Performance, K1 Racegear, NorthStar Battery, OptimumG, Pankl Turbosystems, Pedders Suspension, Performance Plus Global Logistics, PFC Brakes, SCE Gaskets, Setrab, Stand 21, Sunnen Products Company, Supertech, Texsys Sensors, Turbosmart, Turn 14 Distribution, WPC Treatment and many more...



# Getaway drivers

F1 is a ruthless yet sometimes baffling business when it comes to sacking drivers

There is always a degree of amusement, albeit sometimes bitter-sweet, to be had this time of year in Formula 1 as driver announcements for the next year are made.

First prize has to go to McLaren's team principal, Zak Brown, on Stoffel Vandoorne's mooted forced move to Toro Rosso for 2019. 'I'd take him in a heartbeat,' he said – having just sacked the guy! Apart from the obvious question 'so why are you getting rid of him?', there is an inference that what's not good enough for McLaren is nevertheless more than good enough for the Italian team. While appreciating that Brown is talking-up Vandoorne to assist him in staying in F1, could he not see the irony in his statement?

Honesty is in short supply in the shark pool that is Formula 1.

## Stoff's off

The fact is that Vandoorne has under-performed so far, deep into his second year in grand prix racing, and McLaren cannot afford the risk of retaining him for another year. His lack of pace is surprising, given the multiple championship-winning excellence of his results in all the formulae he contested on his way up the racing ladder. He just missed out on winning the notoriously challenging Japanese Super Formula Championship by a whisker at the first attempt, and finished in the points on his first drive for McLaren when subbing for an injured Fernando Alonso.

But the Woking team has to accept quite a lot of responsibility for this, as often the young Belgian has had seriously disrupted practice and qualifying sessions, this lack of reliability extending also to races. A frustrating lack of track time, preventing him building on experience race after race, together with the general lack of a solid and competitive environment in which to develop as a Formula 1 driver, has not helped at all.

Neither has the constant comparison with Alonso. No doubt these factors have messed with Vandoorne's head. However, the harsh reality is that the very best drivers with world championship potential are generally capable of dealing with these situations, putting in occasional outstanding performances when it rains, for example, and, critically, asserting themselves much more strongly

within the team and against their team-mates. Sadly, only when it was too late did we see evidence of Vandoorne kicking back at McLaren, its own under-performance having been largely a source of his under-performance.

## Hart' attack

I also think that at Toro Rosso Brendon Hartley is bound to go; he has not displayed the ability required. What I fail to comprehend is why he was drafted in anyway, straight from prototype racing, where of course he was extremely successful. But the two disciplines are chalk and cheese. If



Despite the fact that George Russell is impressing in F2 he's unlikely to find a seat in F1 next year, while a driver he's beating is off to McLaren

Helmut Marko wanted to allow Hartley a second opportunity after previously being ditched, a season as test and simulator driver for the New Zealander might have given him a fairer chance to adapt rather than throwing him into the deep end. I guess sink or swim is one philosophy, but this approach can be fatal to a driver's F1 career.

## The fast and the furious

On the other side of the coin, other drivers may well be out of a Formula 1 job next year despite great results and displays of real talent, Esteban Ocon being the obvious example. His Mercedes contract has shut the door on available drives, except maybe with Williams it seems, at this point.

Such contracts can be double-edged swords, Red Bull and Ferrari having similar issues with their driver support initiatives. But without them, under current conditions, only pay drivers with very substantial backing would be able to develop

a career leading to the very top of the tree. One cannot blame the teams, they are not willing to take on, short-term, a driver who is beholden to a conflicting manufacturer. Neither, in this case, can one castigate Mercedes' management; having expended a great deal of time and money on advancing Ocon's career, they are not willing to give him up when their investment has begun to bear fruit. The Frenchman may regrettably have to take a one-year sabbatical as a reserve/test driver, but as long as Mercedes retains its enthusiasm for him there is every chance that he can be back – and just maybe in the Silver Arrows works team. Valtteri

Bottas has far from convinced as the likely future successor to Lewis Hamilton and he has no guarantee (if there is ever such a thing in big-bucks sport) of a contract extension beyond 2019.

## The graduate

Anomalies do of course occur frequently. Lando Norris has replaced Vandoorne at McLaren and is being touted as the next Hamilton. Apart from the vacuousness in making any pronouncement of this kind, while Norris' junior racing CV has been outstanding and his Formula 1 tests highly impressive, he has won, so far, just one race in F2. In contrast, his main rival and compatriot, George Russell, has won five and is leading the championship

from Norris, who lies second largely due to his consistency. Lack of one-lap qualifying pace has been given as the reason for Norris not taking more victories, but in Formula 1, even more so, qualifying ability is vital. Russell, by contrast, has not received as much hype and does not yet have an obvious seat for 2019 in any grand prix team. Like Ocon, he is currently a victim of Mercedes having an excess of young talent on its books. A few more racecars on the grid are needed in which to place these talented youngsters.

There is heart to be taken, however, on the teams' side. On top of the rescue of Force India, both McLaren and Williams have made statements acknowledging that their culture, structure, operating methods, resources and just about everything else all need a complete shake-up. The first step in solving a problem close to home lies in accepting that one has one. This is encouraging news at last, not least for their workforces. 

**The reality is that the very best drivers, with world championship potential, are capable of asserting themselves much more strongly within a team**



Clockwise from this picture:  
Ford Fiesta; Toyota Yaris;  
Hyundai i20 Coupe; Citroen C3

# Fantastic four

With a title battle that's set to go down to the wire this year's WRC has not been lacking in drama – and the same could be said of the technical development race too. We spoke to all four manufacturers to get the full story

By MARTIN SHARP

The quartet of manufacturer WRC teams have it all to play for as the World Rally Championship heads to the forests of Wales Rally GB in October. With three rallies to go at time of writing, both the drivers' and manufacturers' championships could well go down to the wire on November's final round in Rally Australia.

And it's not all about the drivers; it is also a battle of constantly evolving technology, as our annual appraisal of the top four cars will show.

## Ford Fiesta WRC

Sebastien Ogier's M-Sport Ford Fiesta WRC arrived at Rally Finland in July with a substantially revised rear end. Aimed at improving the car's aerodynamic performance, it had been developed in Ford Racing's Dearborn wind tunnel by M-Sport chief rally engineer Chris Williams, together with US engineers. 'We thought the new diffuser and





## With homologated suspension parts the scope to make changes to adapt to revised aerodynamics is limited

and technicians are past masters in the art of honing this. But with homologated suspension parts the scope to make changes to adapt to the revised aerodynamics is limited, and the team just refined the rear set-up to make the adaptation to the new equipment.

The FIA rules allow some initial scope. 'For example, we brought in the new aero stuff for Finland; we applied it to one chassis with one driver, so that chassis is now locked to that aero; you can't go back,' Williams says. 'But by next year we have to update all of them. As soon as you put it onto the chassis it gets written into the gold book and then you can't go back.'

The gold book is actually gold in colour, and is effectively an FIA-issued log book for each WRC (and now R5) chassis. On each car's roll cage there is a sticker which relates to its individual gold book. The log book records which events the car has done and also records what jokers are applied to that chassis.

'By technical and homologation regulations we have to update the cars from the beginning of next year, so all cars have the jokers from this year,' Williams says. The teams are allowed a set amount of jokers a year (see below).

### Diff development

The differentials are also part of optimising car balance. While M-Sport made a minor modification to the active centre diff towards the end of 2017, this year there's been much more work in this area. 'We've been quite happily testing new [passive front and rear diff] ramp profiles left, right and centre all the time. It's like our favourite thing to do,' Williams says.

'I'm not sure there's ever an answer to that one unfortunately; we keep on finding new things,' he adds. 'If you look at how Thierry [Neuville] was in Germany; he didn't like the diffs he had in the [Hyundai] and [from that] you can see what kind of effect it has on the drivers. But actually, performance-wise, I think what he had in the car was good on performance but just hard to drive. He didn't like it, which is always a nightmare with drivers; they like cars that are easy to drive whereas the fastest cars are probably not that easy to drive.'

'Every week my diff expert has a new idea. I hate to think of how many diff ramps we've got. You've got front and rear; two to go at, and anywhere from 90-degree down to 30-degree, in five-degree increments, and they're in pairs.'

In this regard M-Sport has received some assistance from Ford Racing. 'We've been running their driveline dyno rig in the States,' Williams says. 'It's very nice and we're trying to

get that thing to work for us. It hints that there's more stuff to do. It can cater for four-wheel drive and all sorts; they can run road car stuff on it and all the motorsport projects can run on it; either just transmission on its own or effectively a full car. It's impressive and it must be £15m or £20m worth of dyno.'

### Jokers in the pack

In 2018 [and 2019] WRC manufacturer teams are allowed three chassis joker and three engine joker modifications, or changes. Ogier's Fiesta WRC's 2018 Finland/Germany spec rear bumper and diffuser used up two chassis jokers. Williams conceded that the new aero arrangement in its Finland format created more drag than the earlier rear treatment. Hence in the week after Rally Turkey in September Williams headed back to the States for more wind tunnel work, which he explained will result in a change which uses up the team's third chassis joker for 2018.

M-Sport also applied for three 2018 engine jokers; revised camshafts, fuel injector and software. Engine development is always on-going and changes have been made during the year, but none requiring homologation.

Interestingly, after Hyundai changed its camshaft drive from a chain to a gear train in April this year, the Ford is now the only WRC with chain-driven cams. 'We have the reasons for going the way we are,' Williams says. 'I wouldn't be an expert in the field, but, potentially, going to gears could be a little bit better, but we have reasons not to do so. There's probably two technical reasons and one financial!'

At Ogier's request his shock absorbers were changed from M-Sport's long-standing Reiger dampers to ZF (formerly known as Sachs) units for Finland. Ogier previously drove on ZFs when he was at Volkswagen before its withdrawal.

'It was an interesting exercise,' Williams says. 'We are continuing our exploration into a different manufacturer. Simply put, we are allowed to use seven sets of dampers, between three cars per rally. Seven sets of dampers, three cars; five sets will be Reiger; two will be ZF. The ZFs are not necessarily exclusively for Sebastian. We've spent a bit of time with ZF. It's a different way of working, let's say, and we're just exploring, and let's see how we go.'

In gravel specification the ZF units are lighter than Reigers and so potentially would be used by Ogier on Rally GB and Rally Australia. 'But, we've always got a set of Reigers. If we're not happy we go with what we know,' Williams says.

In the latter part of this year the team homologated the next level of ZF dampers,

rear bumper would work the best for Finland, so it was a big rush to get it ready,' Williams says. 'More than anything it's the timing; you see the advantage and you want that on the car as soon as you can. We were right on the deadline with that one, but found that there's not a huge amount that needs to be changed on the rest of the car to suit [the aero change]: it's just getting used to it. We've worked so hard on the earlier stuff that we knew where we were with set-ups, and yes it [the change] has an effect.'

Williams adds that the effect on the driveability of the car 'depends where you are, and what you are doing. There are certain circumstances where, yes, it's good and helps you, and other circumstances where you need to be aware of it and the effect it's having. For example, its effect is not as great on Rally Turkey, and there are some downsides.'

The revised aero does not adversely affect car balance, largely because team engineers



**The M-Sport built Fiesta has benefited from input from Ford Racing in the US. The team has been kept busy with ongoing active diff development and rear aero changes**

together with a more easily controlled revised alternator type; and a slightly different louvre in the rear bumper, as Williams explains.

‘Because the louvre is a Variant Option [VO] you can have as many different varieties as you want, which is probably the worst thing on Earth, as we’ve been told by the aero guys, because they can play to their hearts content. And we can have a different one on every rally for every surface. Because they’re VO, you can change it; homologate 20 types and have one for Germany, one for Finland, one for somewhere else. It gives you flexibility.’

Williams is convinced that progress has been made with the development of the car. ‘We know where we’re at,’ he says. ‘We’re working quite a lot with the Ford Racing guys. But we got a lot assistance from them starting the end of last year, and it takes time to do the work and then time to validate the work, test it and get it on the car. So, all the effort that’s come in from them you won’t really see until very late in this year, or the beginning of the next.’

### **Citroen C3 WRC**

This once-dominant WRC team went through some serious doldrums when the C3 WRC arrived on the scene. Citroen had returned after tasting success in World Touring Car racing. Two

chief engineers came and left in the space of not many months and the drivers complained of spasmodic handling characteristics. Then the team boss, Yves Matton, left to accept a job with the FIA as rally director. A PSA stalwart, Pierre Budar, was brought in to replace him.

And then the driver bringing in the better results, Kris Meeke, was sacked after Rally Portugal in May after multiple crashes. Whether this was a Budar initiative or a diktat from the board is irrelevant, but it was hardly the dream scenario for a works team.

But there are now some pretty strong signs that things are improving. Without an official chief engineer, Budar – who understands rally technology – seems to have managed a remarkable turnaround for Citroen.

It’s likely that number one driver Meeke had decided on his preferred car set-up, which suited his attacking driving technique. It also seems Budar was aware of how this affected the other team drivers. So he arranged for that to be changed. ‘In our case, especially for gravel, we had a clear picture of where we could give all the drivers more confidence in the car, which is very important in rally, and especially when the grip is changing,’ says Budar. ‘At the starting point it’s not easy to know, to define, but then we started to have a clear picture and we had

some tests with different drivers, and all the drivers’ feedback was in the same direction, and all the drivers were also positive.’

In the ever-changing conditions of rallying most drivers demand a chassis with consistent characteristics and minimum dynamic change. ‘This is one of the problems we have during testing,’ Budar says. ‘Because when you are on a portion of road they know it in their head after a little while, so they are looking for a racing car, more and more a racing car to improve times, and then when they come to the rally, “Oh, maybe it’s too racy”. So we have to bear this in mind, and for us, when we do testing, one of the most important timings is the first run.’

### **Gravel rash**

Changes made to the car are largely to do with suspension geometry at both ends for its gravel specification. Budar and his team are happy with the existing tarmac arrangements, but what specifically has been changed for the gravel? Here, perhaps understandably, Budar refuses to be drawn into detailed specifics but does concede: ‘We have worked on the roll centre height to be able to play in a different way with the anti-roll bar, springs and also dampers.’

In racing a low roll centre height is often an important goal. But this is rallying, and to give

**After Hyundai changed its camshaft drive to a gear train the Ford is now the only WRC car that is using chain-driven cams**



the drivers better feel the team has actually raised the C3 WRC's roll centre. 'It gives us a larger picture to work with,' Budar says. 'It also gives us a different approach on dive.'

Some rally drivers prefer a modicum of dive to help them set the car up. 'So we had to find a compromise to improve things, and I think most of the drivers are very close [in driving style]; there are not so [many] differences from one to the other,' Budar says. 'The improvement is good enough to be used by the driver, and so in terms of driving it's quite sensible and they are quite happy with the improvement. It's not just a detail of improvement. It's quite an improvement; a significant amount. It required some new parts. We had to invent [design] these, for sure. And we had to use one joker for the rear, for the subframe, for more travel at the rear in the gravel set-up.'

By Rally Turkey there was also new front lower arms, and the team planned to use up all its 2018 joker allocation by the end of the year. The extra chassis joker will not be suspension, but because it will be applied just before the end of the homologation term Budar refuses to be drawn on whether it will be to do with transmission or aerodynamics.

The same philosophy is applied to engine jokers. 'The engine, we have to work on, but we have a good base. And it will be the same scenario; we finalise the development before the end of the homologation term and yes we will use our [2018] engine jokers by the end of this year for our new engine for 2019. So we will start 2019 with some new engines.'

Which, of course, means the team will have a full quota of 2019 jokers for next year.

Citroen has already homologated the maximum of two centre differential front/rear torque split ratios. The ratio used on all of its cars is 48/52 per cent while the ratio on the previous generation of WRC Citroen was 36/64 per cent. 'On tarmac the ratio we use is okay, but we could change, using a joker,' Budar says, hinting at a revised gravel torque split. 'We haven't decided so far to do it and we need some more tests before we make our decision.'

## To give the drivers better feel Citroen has actually raised the C3 WRC's roll centre height

### Toyota Yaris WRC

The Toyotas arrived at Monte Carlo, the first rally of 2018, with revised front bumpers and front fender aero parts. To aid cooling the size of the opening in the front of the bumper is significantly different. The rest of the front bumper changes are more aero-related, with additional dive vanes to change the aero balance percentage more towards the front – in 2017, because the rear end was so efficient, the balance target had not been achieved.

While the front fender shape is almost the same as the old one, the team relocated

the openings to more efficient positions. The openings on the upper surfaces are designed to exhale more heat from the cooling system and the rear openings are essentially about brake cooling and evacuating air from the wheelarch.

Chief engineer Tom Fowler explains that these cooling modifications came about through a combination of CFD and wind tunnel data. 'The wind tunnel data can give big directions, like the shape of the opening in the bumper, for example,' he says. 'Once all those shapes are defined, when doing internal flows it comes more towards CFD, also then evaluation on the full-size car. It's relatively easy to compare cooling as long as you make a big enough difference; you can see by using temperature sensors and additional sensors in the test car. So, it was kind of a three-way process. Not all of the cooling items were fitted for Monte Carlo, as Mexico was where we had the problem last year and the reason why we've done all this work.'

'Mexico 2017 was a total disaster; Mexico 2018 was a partial disaster,' Fowler adds. 'We had made updates already to the cooling system between '17 and '18, but in fact the step we made wasn't enough: the temperatures we had in Mexico in 2018 were actually something like 10degC hotter than they were in 2017. So we needed to make a 10degC difference in order to stay the same. We improved, but not enough.'

### Cold Turkey

Which meant revisiting the problem. 'We started some development work on some new parts, and after Mexico we sped that up; because obviously we had the information then that Turkey was going to be our next cooling-



**Citroen has a new boss and a new approach to chassis dynamics, concentrating on developing its C3 WRC so that it's less edgy for the drivers while also making it a more potent force on gravel rallies**





Toyota's major headache last season was with the cooling of the Yaris WRC. It has worked on this in both the wind tunnel and in CFD, while TMG has further developed the engine

dominated rally,' Fowler says. 'So we worked on those parts and we've been testing those during this summer and they were fitted for Turkey.'

It is a completely new cooling package with a much bigger step; in the region of 20 per cent more cooling capacity than the team had in Mexico this year. Testing in Portugal two weeks before Turkey was in 35degC ambient temperatures and over slow technical roads similar to some used in Turkey, making Toyota confident that its revised cooling works.

That confidence was rewarded in a gruelling new event where recces were not allowed. This was because FIA rules only allow testing in Europe, and the Marmaris area of Turkey was the 'wrong' side of the Bosphorus. This meant all crews starting from a level pace note playing field, with no reference to previous experience of stages, while the engineers had little real knowledge of the stage conditions.

Toyota Gazoo Racing WRC scored a one-two on that landmark new WRC event, and the cars' revised cooling worked properly without it having to resort to jokers. 'The only cooling part that's included in the homologation is the intercooler, so we kept the intercooler the same and worked around it with new radiators and new ducting, all of which was rearranged around the intercooler,' Fowler says. 'Radiators and ducting are free, so there was no homologation needed. Inlet and everything is the same, it's just that the physical radiators are different. The fans are different and then the ducting work that joins it all together is

different. All that is free, except for the fans, but these are in Variant Option, so we were allowed to add what we wanted there.'

Before Turkey the team had one chassis and one engine joker remaining from its 2018 allocation. However, there were no update plans for the rest of the year; the remaining 2018 joker to be homologated is transmission parts for gravel and will therefore be most likely to appear on the 2019 Rally Mexico. Once the joker homologation paperwork is in place teams have six months to install the equipment.

## Usable power

An important change came for Rally Finland this year when a revised engine specification was introduced. The team's engines are designed and built by Toyota Motorsport GmbH [TMG] and TMG's Norio Aoki explains that performance and driveability were the priorities. 'I think from an engineering point of view when people talk about the power, I imagine a power curve. When people talk about torque, we imagine the torque curve. When driveability is mentioned we imagine how easy it is to drive,' he says.

'When the driver says torque, does he picture-in the torque curve?' Aoki adds. 'Maybe not, because in the end power is torque, so I think it's important to align what the driver feels

from the driver comments. The interpretation of this in the engineering world needs to be realigned to what they want, and I think from that point of view, in general, we achieve this. We get power in a good way.'

The result is an engine with a similar amount of maximum power as before but not at the same rpm. The philosophy was to shift the whole torque band further up the rpm range for the new engine. 'Because the engine is boost-limited in lower speed and the high-speed area is ruled by the restrictor, the characteristics are such that I think we want it to always get more power and more torque,' Aoki says. 'But also I don't want to say "we have very big power" and then make a peaky engine, which is useless. So I think with this spec our chief [aim] was to really shift the torque curve up in a magnitude that we even surprised ourselves with.'

Aoki would not be drawn on the specific tactics employed to achieve these improvements, preferring to refer to modifications to the valve train timing, and in the way the valves open, and also software changes, of course. But when Ott Tanak blitzed Rally Finland to win with the new TMG engine the other teams were forced to sit up and take notice of the sheer speed of the Yaris WRC on what's nicknamed the 'Finnish Grand Prix'.



**Toyota's philosophy was to shift the whole torque band further up the rpm range on its new engine**

# pankl

RACING



High Tech | High Speed | High Quality

Pankl Systems Austria GmbH  
Engine Systems

A-8600 Bruck/Mur, Kaltschmidstraße 2-6  
Phone: +43(0)3862 51 250 0  
Fax: +43(0)3862 51 250 290  
e-mail: engine@pankl.com

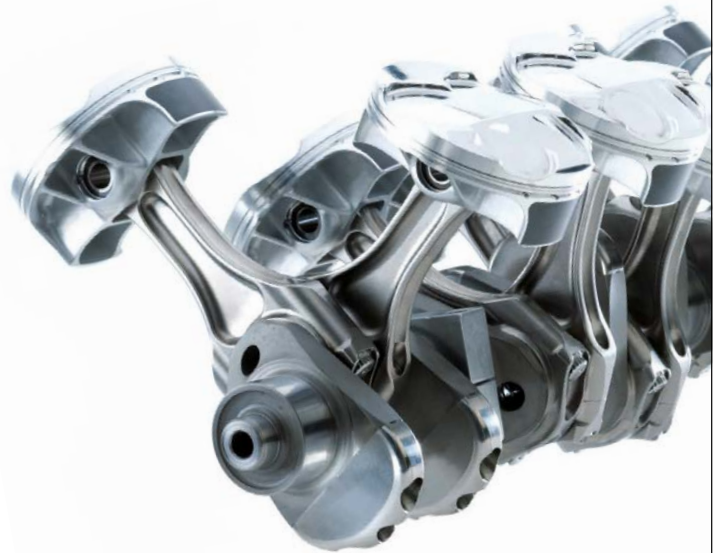

[www.pankl.com](http://www.pankl.com)

# REIGER<sup>®</sup>

## SUSPENSION

DRIVEN BY  
THE AMBITION  
TO BE THE  
BEST

YouTube f

THE BEST SHOCK ABSORBERS FOR:

RALLY - RALLYCROSS - RALLYRAID - AUTOCROSS - MOTORCROSS - ENDURO - TRIAL - QUADS - SIDECAR



Reiger Suspension BV  
Molenk 5a  
NL - 7255 AX Hengelo Gld

+31 (0)575-462077  
[www.reigersuspension.com](http://www.reigersuspension.com)  
[info@reigersuspension.com](mailto:info@reigersuspension.com)

## At 2570mm the Hyundai i20's wheelbase is the longest of all the WRC cars, improving its stability on fast rallies

### Hyundai i20 Coupe WRC

At 2570mm the Hyundai i20's wheelbase is the longest of all the top WRC cars, improving its stability on fast rallies, but reactivity in twisty sections can be a problem compared to rivals. The team runs the car with the minimum wheelbase dimension allowed by the FIA tolerance rules, plus, as team principal Michel Nandan says, 'you can change, of course; to have a car more reactive you can work on the diffs; you can work on geometry, different things. So, it's true that we are working on that in order to improve this problem.'

'For example, our car is not good on tarmac,' Nandan adds. 'This is a surface where we need to improve. We have improved this year, but the step was quite small compared to some other cars. The other WRC cars did take a big step; Toyota, for example, took a big step on tarmac.'

But the majority of WRC rallies are gravel events; a surface over which the Hyundai shows good form. 'We are not bad I have to say; depending on which type of gravel you have,'

Nandan says. 'It's true that on the type of road like Argentina, Portugal, or even Sardinia, our car is quite good. I think the car has some plus and some minus points, so we are trying to eliminate the minus; but it is always small steps.'

'In terms of durability, yes we have improved compared to last year, because it was our target number one,' Nandan adds. 'You can still have a problem, but overall, if you look at the first part of the season, durability-wise the car was not too bad, I have to say.'

'In terms of performance it's a bit up and down. It's not bad, but if you look at it event by event you have some cars which are maybe faster, depending on the rally.'

### Snow joke

In addressing these issues the team presented two engine and two chassis jokers to the FIA for October 1 homologation. These complete Hyundai Motorsport's 2018 joker allocation, although requests for 2019 jokers will be made soon, to take the Hyundai team into the Monte Carlo Rally opening round in January.

In April Hyundai took the option to homologate gear train-driven camshafts in place of the previous chain drive. The two October 1 engine jokers relate to a cylinder head with revised ports, plus a lighter weight cam cover to improve overall weight distribution.

Since Rally Finland the Hyundai has been running a Moog valve to control the centre differential's hydraulic system and for October the team has requested the use of a revised, different capacity hydraulic pump. The second,

and final 2018 chassis joker is for more durable front suspension wishbones.

Thierry Neuville struggled to become comfortable with the car's chassis on the tarmac of Rally Germany earlier this year and therefore some changes were planned for Rally Spain. 'We will probably use different front and rear diffs, because the ones we had in Germany were the same as the ones we had in Corsica, and we have also the possibility to use a different centre diff torque split,' Nandan says.

The original homologated centre differential front/rear torque split is 43 per cent/57 per cent, but an alternative was homologated in April. This is biased more to the rear with a 37 per cent/63 per cent ratio. Work continues on geometry-related suspension changes for gravel, and Nandan considers it is possible this will involve using a 2019 joker.

The i20 Coupe WRC's aerodynamic treatment has worked well through 2018 and Nandan believes that modifications to this will probably not be necessary next year.

### Finely poised

After Rally Turkey in September the Hyundai team was just five points behind Toyota at the head of the manufacturers' standings, and its driver Neuville was 13 points ahead of Toyota's Tanak in the drivers' ranking. Ford M-Sport was 35 manufacturer points down on Hyundai, while its five-time champion, Ogier, lay just 10 points behind Tanak in third place. But there's a lot more rallying to be done before this WRC season is done and dusted.



Hyundai's working on improving its i20 WRC's pace on the tarmac rallies and to this end it has homologated a new centre differential with a torque split that's biased more to the rear

**KAISEER®**  
RACE TECHNOLOGY

SOLUTIONS MADE OF PASSION

## HIGH TECHNOLOGY FOR WINNERS

Formula 1 is the greatest challenge a manufacturer of mechanical components may ever be confronted with. We have embraced this challenge and have attained the status of top supplier with our high tech products.

At Kaiser we manufacture the Chassis-, Engine-, and Gearbox Components our customers require.

... JUST GOOD IS NOT GOOD ENOUGH FOR US!



[www.kaiser-wzb.de](http://www.kaiser-wzb.de)





# All time Lowe

The once mighty Williams team looks set to register its worst ever F1 championship result with this season's troublesome FW41. *Racecar* spoke to its technical director, Paddy Lowe, to find out why things have gone so desperately wrong with its 2018 car

By SAM COLLINS

**T**here is a quote, incorrectly attributed to Winston Churchill, that appeared on the internal staircase of the Williams F1 motor home recently. It reads:

'Success is not final, failure is not fatal: it is the courage to continue that counts.' It's a sentiment that sums up the 2018 season for Williams.

With nine world championships and 114 race wins under its belt this team certainly understands success, but considering that it has only won a single race in the last 14 seasons, and that 2018 looks likely to be its worst ever world

championship campaign, this is also a team that now also understands failure.

Yet at the start of 2018 it was clear that Williams believed it was about to turn around its slump. The team had achieved a major coup at the start of the 2017 season by securing the services of Paddy Lowe as its technical director. Lowe, who had overseen the development of the dominant Mercedes cars of 2014, '15 and '16, aimed to bring some of the Mercedes formula for success with him. As he joined the team too late to have a significant influence on

the concept of last year's FW40, the 2018 FW41 was the first car which would really show the influence of Lowe's arrival, and at the team's season launch he was optimistic.

'We are reluctant to say we want to come third, or fourth or fifth, because we cannot predict what others have done,' Lowe said back then. 'One of the things we can measure ourselves on is absolute performance; we would like to see a lap time gain against the guys who were taking pole last year. In that sense with this car we are trying to achieve an element of step





change and not just a progression, we were two seconds or so a lap slower than the frontrunners in 2017 and that is something we would like to close up considerably. Broadly we have met the performance targets we set internally, but there are a couple of caveats to that. Firstly, were the targets ambitious enough? Second, will that performance translate to the real car?

That mention of the 'real car' was particularly telling, for at the event in London the physical car was not present. Instead a computer generated rendering of it was projected on to

a screen. While many details of the racecar's design were essentially redacted in the images provided, the overall layout of the FW41 was clear to see, with quite a number of the cues carrying over from the 2017 FW40.

### Special case

Like the FW40 the new design featured pushrod actuated front suspension and a pullrod actuated rear end. Once again the transmission would be an in-house design with a cast aluminium casing, mated to the latest

specification Mercedes power unit. This choice of transmission design means that the FW41 is unique on the 2018 Formula 1 grid as the only car not to use a carbon fibre main case.

'It is a different gearbox to last year, but it is based on a similar philosophy to that of the FW40,' Lowe says. 'It is certainly more traditional than perhaps other designs, but using this material means it is not just cheaper but also quicker to manufacture. Compared to a carbon fibre gearbox you can get similar performance so it is really a very cost effective

## TECH SPEC: Williams FW41

### Chassis

In-house carbon fibre monocoque.

### Power unit

Mercedes-AMG F1 M09 EQ Power+. Internal combustion engine: 1.6-litres, 6-cylinders; bank angle 90-degree; 24 valves; max rpm ICE 15,000rpm; max fuel flow rate 100 kg/hour (above 10,500rpm); high-pressure direct injection (max 500bar, one injector per cylinder); pressure charging single-stage compressor and exhaust turbine on a common shaft; max rpm exhaust turbine, 125,000rpm.

### Transmission

In-house aluminium casing with eight forward speeds (plus reverse) electro-hydraulic sequential shifting, carbon multi-plate clutch.

### Suspension

Double wishbone all round with pushrod actuated springs (front) and pullrod actuated springs rear. In-house dampers.

### Cockpit

6-point driver safety harness with 75mm shoulder straps and HANS system, removable anatomically formed carbon fibre seat.

### Cooling system

Aluminium radiators for water, oil and ERS fluids. Centreline cooling.

### Steering

In-house power assisted rack.

### Brakes

Carbon/carbon with AP Racing calipers (6-piston front, 4-piston rear).

### Wheels

Forged magnesium by Dicastal.

### Dimensions

Overall height, 950mm; overall width, 2000mm.

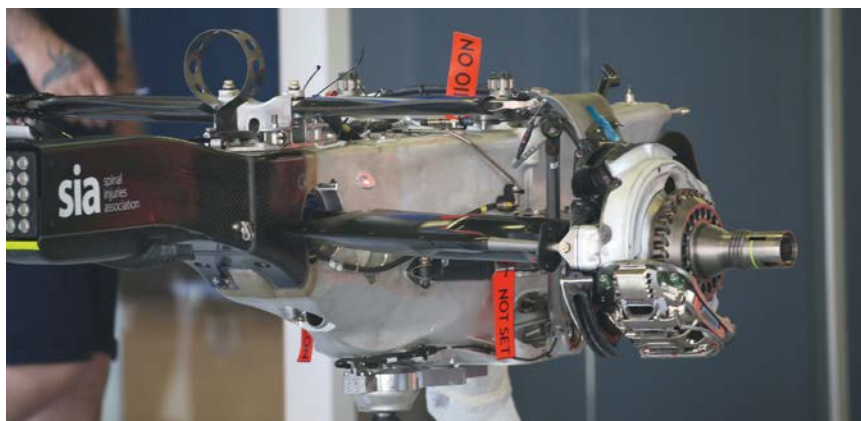

Williams is the only team on the F1 grid that does not use a carbon fibre transmission casing, but it says its bespoke cast aluminium design not only works very well but is also cost effective and quick to manufacture

## It was soon evident that the aerodynamics of the car simply did not work as expected

solution. Some of the carbon fibre designs out there are incredibly complicated and incredibly expensive and it has not really been proven that that is good value for money!

### Error messages

The final car rolled out of the garages at Barcelona on schedule and after a quick photography session took to the track, at which point hearts sank at Williams. Something was wrong with this racecar. Very wrong.

'From the minute the car first ran it was clear that there were some issues we had to deal with,' Lowe admits. 'The pace of the car was really quite bad. This was because there was something disrupting the drivers' ability to get anywhere near the limit with the car. There are many things which are good about this car but they were not apparent, as the whole car was let down by this particular aspect.'

It soon became clear that the aero simply did not work as expected. Team members have since revealed that there have been issues with the floor stalling in unpredictable ways, as well as other undesirable aerodynamic traits.

'There is not a single underlying cause for the issues, only in the sense that if you look at

the spread across the whole grid, the bulk of that performance gap is around aerodynamics,' Lowe says. 'There is a gap of about two to three seconds across the grid. There are some differences in engines across the grid but I think that gap between cars is mostly explained by aerodynamics. Aerodynamics is the most significant differentiator in this sport despite what some may say. Engines are not such a big deal now they have converged, the best six cars in the field have three different engines, so it is rather self evident that that is the case and that it is aerodynamic performance holding us back.'

'Many of the problems of this year's car are simply exaggerations of those we had last year,' Lowe adds. 'The degree of instability of our car has been very extreme this year. Last year's car was not great in terms of stability, but that feature has become even worse on this year's car. You have to go right into the heart of what you are doing, and do some core science on how you are generating performance.'

### To boldly go

Perhaps one of the reasons that the FW41 suffered such significant aerodynamic issues from the outset is the overall philosophy of the car, and its aim of delivering a step change in performance relative to its competition. In this respect it appears that while the team did take a step, it tried to go too far too fast.

'If we talk about aerodynamics, which is the main aspect of the programme from last year and this, there were some decisions taken about architecture which were quite bold and were an aggressive departure from what we had done before,' Lowe says. 'It is fair to say at this point that a lot of that did not work as intended. It has impacted not just on the performance of the car but also on the programme of the car development, everything you do takes capacity and you don't use that capacity on other parts. When you add all that up it makes

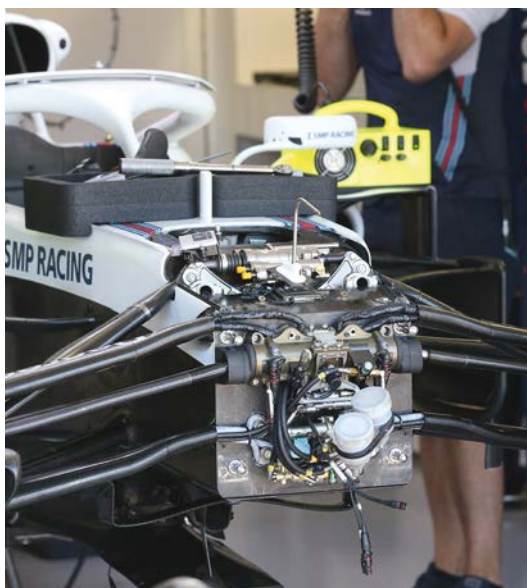

The front bulkhead showing the in-house designed steering rack and the suspension rockers, usually mounted under a vanity panel



Mercedes power unit installation in the FW41. Paddy Lowe says there is more to be gained with aero than PUs this season

# INTELLIGENCE CONNECTED

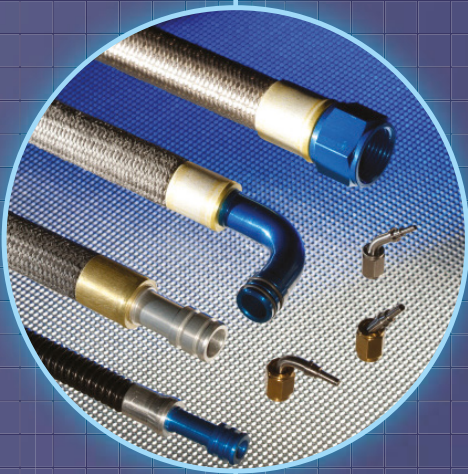

Flexible Hose and Fittings

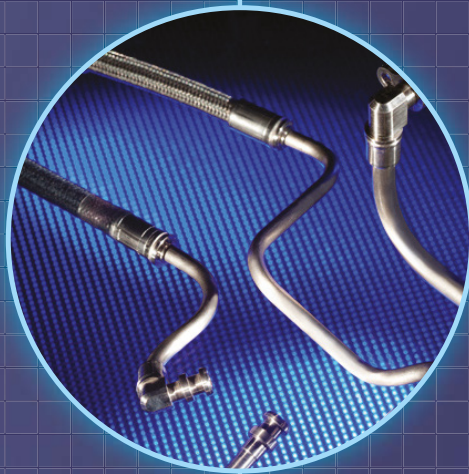

Rigid Lines and Swageloc



Filtration

It's not by accident that, over the years, we have developed many successful partnerships with customers throughout motorsport – particularly in F1, endurance racing and WRC.

By applying intelligent analysis of their problems in the area of fluid transfer in high performance, high energy situations, we have established ourselves capable of providing innovative and cost-effective solutions.

## SERVICES:

- 3D cad design service
- hose assembly
- hard-line manufacture
- cnc machining
- filtration design
- laser marking

## PRODUCTS:

- **Titeflex smoothbore and convoluted hose products and fittings**
- **Swageloc fittings and hard-line system solutions**
- **Pall Filtration systems**
- **CIRCOR Industria solenoid valves**

# FHS

MOTOR RACING

INTELLIGENT CONNECTIONS

Maintain system integrity, save weight, cut costs.  
**Make the connection now.**

To find out how the quality of your own fluid transfer requirements can be improved, call our Technical Sales Team on

**+44 (0) 1753 513080**



FW41 has often been seen covered with bright splashes of flow visualisation paint as the team tries to understand its aero issue. This mainly involves the floor stalling in an unpredictable way



The undercut sidepods shown with the bodywork removed; note the low position of the side impact structure. The FW41 has the largest undercuts in Formula 1

## ‘Nothing gets solved by getting sad and emotional, it’s a technical problem and you have to get out there and make the car quicker’

a big difference. Ultimately, what we have done is produce a car where steps have taken us backwards. On top of that, it’s uncovered a range of areas in which we have slipped behind in terms of our capability and process to develop the car. That’s been disappointing.’

One of the most visible areas where Lowe’s ‘bold and aggressive’ approach is evident is with the sidepods. The FW41 features an extreme version of the short sidepod concept which requires the side impact structure to be moved from its conventional location to a point lower on the side of the chassis, which in turn requires substantial structural beefing up. While in theory this layout can offer some aero gains it’s worth noting that Lowe’s old team, Mercedes, opted against doing this as it was felt to be too difficult to achieve without a performance loss.

‘It does not take much studying to see that we have very much the largest undercuts in the pit lane and it is clearly not a winning formula,

certainly not in the way we have delivered it,’ Lowe says. ‘To change that would be a big change, it would mean a chassis change, we would have to re-visit the whole cooling package and all the bodywork. Perhaps a much larger team could contemplate doing that but at the moment we don’t have the capacity to do that during the season without sacrificing an awful lot of other work.’

Developing such complex areas clearly took the emphasis off other areas of the racecar, and this remains a clear irritation for Lowe. ‘We put our focus on some areas which did not deliver, and by definition that means we have not put our focus on areas that would have delivered,’ he says. ‘There is now a lot of work back at base to revisit and we also need to look at how we design cars generally, and there is certainly a lot of room for improvement there. That is probably true in all teams but it becomes especially focussed if you are not performing as you wish.’

### Axles of evil

As the quote on the wall of the motorhome mentioned at the beginning of this piece (which likely has its origin in a 1930s advert for Budweiser beer, incidentally) states ‘failure is not fatal, it is the courage to continue that counts’. And this is the attitude Williams took after the first few races of the season. Once it had identified and understood the issues with a FW41 Lowe instigated a plan to try to get the racecar working as it should.

‘I think we lost our way in a number of critical areas,’ Lowe says. ‘We put in place a recovery programme to bring back performance to the level the car was intended to operate, and this was timed to be completed mid season. We felt we had a very good understanding of what was letting us down, and we also felt we knew how to correct it, but we knew it would take time.’

That recovery programme did not go entirely to plan, and as new parts were introduced to the FW41 ahead of the British Grand Prix again something went badly wrong with the aerodynamic performance of the car. Both drivers found it impossible to drive and they each ended up in spectacular spins.

‘We suffered from a phenomenon which we had not seen all year, or indeed ever before, whereby the DRS activation intermittently caused a complete loss of aerodynamic floor loading which did not recover at the entry to the subsequent corner,’ Lowe says. ‘The cars would enter the corner with no load in the floor which had obvious consequences. We saw the phenomenon once in free practice one, but it was incorrectly diagnosed to be related to a particular configuration which we chose not to carry forward for qualifying and the race.’

Once the problem was identified correctly the team was left with no option than to fit older spec rear wings at the last minute, which saw them both start from the pit lane – a sorry sight for most of the factory staff who had come to the track to see the cars in their home race.

### Fighting back

Despite setbacks, however, the programme to improve the FW41 did progress and deliver results and at the Italian Grand Prix at Monza, for instance, the car even looked competitive, getting into the top 10 in qualifying.

‘It should not be said that the car has not improved; this is a better car than the FW40,’ Lowe says. ‘It is just that the sport moves week by week, and we have not moved as fast as others, we have under-developed and been out-developed. Some of that is because we made choices that were too aggressive, but at the time we made them they made sense, we were ambitious, we had to be. We’ve done a lot



The rear wing was changed for the British GP but this caused big problems for the drivers and Williams went back to the original



## **Start thinking about a new future in a challenging and rewarding career. Act now and apply to be a member of the PWR Group.**

PWR are world leaders in using advanced cooling technologies to provide bespoke thermal solutions to all forms of motorsport, automotive and hybrid electric markets with locations in Australia, USA and Europe.

Our customers require the best in design, manufacturing and service. PWR continues to deliver with increased investment in skilled staff and latest technology equipment.

Due to PWR's business growth, we are expanding our workforce with a diverse range of engineering and manufacturing career opportunities in our state of the art facilities in Queensland Australia and Indianapolis USA. Successful applicants emigrating to either manufacturing facility will be assisted with Visas as required.

If you are a passionate and driven person wanting to further your career, then join PWR as part of a highly motivated global team.

We are looking for the following candidates;

- CNC Machinists (MasterCAM and 5 Axis experience viewed favourably)
- Design Engineers (Solid Works experience an advantage)
- CNC Programmers (MasterCAM an advantage)
- Aluminium TIG welders
- CFD Engineer

Male and Female applicants are encouraged to apply in all positions.

If this sounds inspiring to you please email your resume to [careers@pwr.com.au](mailto:careers@pwr.com.au) or visit our careers page at



[/pwrperformanceproducts/](https://www.facebook.com/pwrperformanceproducts/)

[careers.pwr.com.au](https://careers.pwr.com.au)

[/pwrperformanceproducts/](https://www.instagram.com/pwrperformanceproducts/)





Williams bucks convention by being the only team to mount its dashboard on to the chassis rather than on the steering wheel



The FW41 uses the centreline cooling philosophy which is a feature of all the Mercedes powered Formula 1 cars this year

of very good work, but when you go and look at the numbers, we've probably stood still relative to our competitors. We're not going to give up, but if we're realistic, the idea of getting back towards the front of the midfield at this stage in this season is maybe not going to happen.'

## Moving on

A major change in aerodynamic regulations for the 2019 season was announced shortly before the mid-season break, and that has to an extent forced the team to decide that the FW41 is something of a lost cause, though work on it has not stopped entirely. 'I think with all the teams, late in the season you switch resources to the next year, especially with a significant set of new regulations coming in,' Lowe says. 'We continue to work on aspects of the FW41, but the character of those projects is very much around things which either directly or at least in terms of information and knowledge can be carried over to 2019. We are no longer working on things specific to this car.'

At the time of writing Williams sits last in the constructors' championship, but this situation has not disheartened the team. 'This has been the most difficult season in my career, managing a team which has not got where it wants to go,' Lowe says. 'This car, for all its disappointment performance wise, took an extraordinary effort to deliver on time, probably the biggest effort in the history of the team. That is what

makes me so proud of this team. Even with the disappointment we have stuck at it and worked at taking the knowledge and lessons learned from this car into next year's car. It is always disappointing when you produce a car which does not realise your hopes. You have to regroup, have another go, so I'm proud of the endurance, dedication and loyalty of the team. Nothing gets solved by getting sad and emotional about it, it is a technical problem and you have to get out there and work at it to make the car quicker, or make another car that is quicker. It is no use feeling sorry for yourself.'

## Aero opportunity

As the attention of the team has turned now to 2019 and the forthcoming Williams FW42, once again there is a plan to make a major step forwards, this time having understood the lessons of 2018. 'Our aims and ambitions remain the same as they were, to make a big step and get to the head of the grid,' Lowe says. 'I hope that the dedication the team has shown this year along with better processes and a better technical approach applied to the new car design will let us achieve that. I have a lot of hope and indeed confidence that we can do that. The last time we really had such a significant change to the regulations was back in 2009, and then you saw considerable disruption within the pack.'

'The new aerodynamic regulations provide a good opportunity, the field will kind of be reset in some areas of the car, and that will let us exploit some things,' Lowe adds. 'And it's going to be very interesting indeed in February or March to see where things land.'

## 'The cars would enter the corner with no load in the floor, which had obvious consequences'

### F1 tech update: Floor flaws

It is not only Williams that has struggled with the floor of its car in 2018. At the Italian Grand Prix one of the Haas VF-18s was disqualified for running with an illegal floor.

Ahead of the summer break it had become clear that a number of teams had interpreted a regulation relating to the shape of the leading edge of the front splitter differently to the FIA. The rules state that the outer corners must have a 50mm radius, but some teams, including Haas, exploited what they felt was a loophole allowing them to claim that outer parts of the splitter were in fact parts of the barge board and did not have to comply with the 50mm rule. A technical directive was issued outlawing this practice which gave the teams concerned until Monza to comply. Haas did not comply.

Following the race at Monza the Renault team (which is locked in a tight constructors' championship battle with the US owned Haas operation) protested the VF-18. Haas argued that it had asked for extra time to produce new parts, and it had emailed Nicholas Tombazis, the FIA's head of single seater technical matters in

response to the technical directive. In the email it provided drawings of a new design of front splitter and it stated: 'Given the forthcoming summer break, we will endeavour to introduce this upgrade for the Singapore Grand Prix but we are somewhat at the mercy of our suppliers and request some flexibility in this matter.'

Tombazis responded to the team in regards to the legality of the new design but

**Below: Earlier this season Haas had been running its VF-18 with a fully legal front splitter and floor, complete with the 50mm radius the FIA requires**



At Monza the leading edge of the front splitter did not have the required 50mm radius

not in regards to the proposed timing. Haas seemingly took this response as acceptance of its request for flexibility but both Renault and the Italian Grand Prix stewards saw things a little differently and the car was disqualified.

At the time of writing Haas had notified the FIA of its intention to appeal.

# Performance focused engine components



For over 40 years we've been manufacturing performance focused engine components. Our British made quality means you'll find us at the heart of the world's most powerful engines.

**Call us +44 1455 234 200**

Exhibiting at:

**Professional  
MotorSport**  
WORLD EXPO 2018

**PRI**  
DECEMBER 6-8, 2018  
INDIANAPOLIS, IN • USA

**AUTOSPORT**  
INTERNATIONAL  
ENGINEERING  
SHOW

OVER 40 YEARS OF  
BRITISH ENGINEERING



© Arrow Precision Engineering Ltd Est.1974

Discover innovation at  
[arrowprecision.com](http://arrowprecision.com)

# The generation



Images: DS Performance/Katy Fairman

**Formula E's Season 5 will not only feature a radical new car and no mid-race swaps, but also a whole host of fresh technical challenges – as *Racecar* discovered when we attended a private test session for the DS squad's Gen2 racer**

**By SAM SMITH**

**P**ivate testing days, of which just 15 are afforded to the nine confirmed manufacturers in the FIA Formula E Championship, are intense affairs. This is especially so when a brand new car is involved and every kilometre of running counts. Which is why it was a big deal when *Racecar* was invited to the Calafat circuit in Spain where the DS Automobiles Formula E squad was working on a variety of programmes in preparation for Season 5 of Formula E, which is set to spark into life in Riyadh, Saudi Arabia, in December.

This was also the first ever test in which DS had collaborated with new team partner Techeetah, while new driver Andre Lotterer was at the wheel when *Racecar* was in attendance.

The team has now completed all of its allowed development testing with the DS E-Tense FE 19. It's rumoured that DS, along with Audi, are the two teams who have made the most progress with their overall Gen2 packages so far, but everyone will have to wait

for the single official Formula E test in Valencia in the middle of October to know for sure.

Managing the Calafat test was DS Performance Formula E project manager, Thomas Chevaucher, who has been an integral part of the DS FE story since 2015. Chevaucher is set to hold a joint technical development lead role with Techeetah's Leo Thomas for the new season as the new alliance aims to try and topple the Audi Sport Abt Schaeffler squad, which took last season's teams' title.

'It has been an intense period, but this is racing sometimes,' Chevaucher says. 'What we have worked on is improving the efficiency in many areas, but in Season 5 there are two main improvements overall we are focusing on. One is the energy recovery, which goes from 150kW to 250kW, which makes a massive difference on braking. The other is that we now have a brake-by-wire system and not a normal hydraulic distribution, and this improves massively the efficiency of energy recovery.'



# game



DS is utilising its own brake-by-wire system as part of its goal to use the programme to showcase road car technological developments.

The Gen2 car also features a battery supplied by McLaren Applied Technologies, which provides almost double the energy capacity as the outgoing model, so that the cars are able to complete a full race distance with no mid-race car swap, which had been a feature of Formula E during its first four seasons.

## Worth the weight

The new car weighs 900kg with the driver (100kg up on the old car), including 18kg from the new Halo device. The battery, which is no longer a stressed part, weighs approximately 389kg, which is 47kg heavier than its Williams-provided predecessor. This also gives the car a higher centre of gravity than the previous racer. Meanwhile, DS claims it has achieved a 30 per cent weight reduction on its powertrain between last season's car and the new model.

But it could be the change in race format that will be the biggest challenge and Chevaucher believes the new approach of 45 minutes plus one lap for a race will be a crucial tactical challenge. FE ran races to a lap count in its first four seasons, sometimes deriving criticism for too much lift and coasting, which even caused one race winning driver to exclaim that 'it's like being in a bloody boat sometimes, putting up the sail and waving people through'.

'For the fans the 45-minute regulation is a good idea, but for the engineers it will be a nightmare,' Chevaucher says. 'It is quite easy to simulate in testing and we have done some of that. The point is that the end of the race will be dictated by the leader, their pace, and when they cross the line after 45 minutes. If you are not the leader it is hard to anticipate and if they have a three second gap they could slow to save. Strategy wise this will create new situations and it will be very interesting to see who adapts and who doesn't.'



New battery has almost double the energy capacity of the old unit



The Gen2 car weighs in at 900kg, which is an increase of 100kg over its predecessor, while it also has a higher centre of gravity

**'For the fans of the series the 45-minute plus one lap regulation is a good idea, but for the engineers in the teams it will be a nightmare'**

In what Formula E is billing as a 'world first for motorsport', drivers will be able to access a higher power mode – this is in addition to the proven Fanboost system, where fans vote for a driver during the race and the one with the most votes gets a power boost. This new boost system will be triggered by passing through 'an activation zone marked out and visible on the circuit for fans at the track and those watching on TV. When the racecar passes through the activation zone, the driver will be able to deploy 225kW of power, as opposed to the standard 200kW available during the race.

A new innovation that is set to be unveiled at Riyadh will be the signalling of the power hike via a new illuminated FIA Halo head protection device, which will show different colours for each of the two power modes. The precise number of individual uses and relative duration of the higher power mode will vary at each event and will be determined by the FIA prior to race day. It will then be up to the teams and



DS pilot Andre Lotterer believes the new cars will offer spectacular action and will present a 'nice challenge' for the drivers



Michelin has worked on widening the operating window of its tyres. The suspension is similar to that of the outgoing FE car

drivers to decide when to activate the higher power mode throughout the race, within the limits that will be set by the FIA.

Another new aspect for Season 5 is the new range of Michelin tyres. The new front tyre weighs 2kg less than its predecessor, while the rear is 2.5kg lighter. That's a saving of approximately 9kg – almost 20 per cent – per set. Crucially, the drivers will not have the luxury of fresh tyres at 'half-time' anymore, thanks to it now being one-car/one-driver for the entire duration of the races.

'I'm not part of the group which says that the Season 4 tyres were not good, because I think it is a real challenge for Michelin to make a product that is able to do the qualifying, the race, and wet and dry running,' says Chevaucher. 'So, it is normal that outside the window of

the tyres it got challenging to find the right operating parameters. I think the window is even wider now for the tyres, and the performance is even better, so Michelin have done some very good work here. But again, we will for sure find some conditions when we are outside of the window and it will catch some people out, I have no doubt about this.'

## Kerb enthusiasm

While there is change throughout most of the Season 5 technical package, the suspension is said to be one of the less critical areas. 'The challenge is pretty much the same as it was for us in previous seasons from the suspension point of view,' Chevaucher says. 'With big kerbs and bumps on most of the circuits we race on in Formula E, I expect there to be a good

evolution of packaging at the rear of the car. [But] it is conventional suspension because the regulations limit the design, because this is not the area where we need to spend a lot of time, we want to focus on the powertrain efficiency.'

## Set-up work

DS driver Lotterer believes the Gen2 car will be good to watch. The three-time Le Mans winner racked up considerable mileage in the DS car from June to the end of September. 'The challenge is closer to what I am used to because I can call upon all the development I did in LMP1,' he says. 'Being in this kind of set-up is much more familiar as I can positively help in tuning the car and work on the set-up. There is much more to work on with this car. The power is a noticeable step, especially at 250kW. Qualifying will definitely be a nice challenge and it should be a great spectacle.'

Lotterer, who has helped develop electric brake-by-wire systems with the Audi and Porsche LMP1 hybrids, believes his previous experience will now pay dividends in the all-electric series. 'The brake-by-wire is quite similar to what I have used in LMP,' he says. 'We have been altering it with re-gen and different

## 'Energy recovery goes up to 250kW, which makes a massive difference to the braking'

powers in testing and you have to be fairly precise. There are generally more tools for us to use to assist now, for sure, but it will still be a big challenge on set-up and getting everything right on small and bumpy street tracks.'

Yet although Lotterer is positive about the new car, he has voiced concerns that the new single-piece front bodywork can break off easily due to contact. 'In the old car there was some wheel banging you could get away with, but maybe you won't be able to with this car,' he says. 'I think you will see a lot of damage to the front section especially as it is all in one piece.'

After the season opener in Riyadh in December FE will go to Marrakesh (Morocco) in mid-January; and as yet to be announced venue at the end of that month; Mexico City in mid-February; Hong Kong in mid-March; Sanya in China at the end of March; Rome in mid-April; Paris at the end of April; then Monaco in mid-May; Berlin at the end of that month; another venue yet to be announced at the start of June; then it will finish off with two rounds in New York in mid-July. If earlier indications are anything to go by, it promises to be an interesting season for Formula E.

# Hear from the Experts!

Pro Stock drag race engines are the pinnacle of engineering for normally aspirated engines. The best air flow through the ports and manifold is critical. A perfect seal between the rings and the cylinder wall is critical. Hear what the experts say about their Rottler machines:

*"The Rottler P69 with its advanced software allows me to reverse engineer, modify, and produce absolutely accurate cylinder heads and manifolds faster than any of the systems I've previously used."*

– Warren Johnson  
The Professor of Pro Stock

## Rottler CNC Cylinder Head Machining

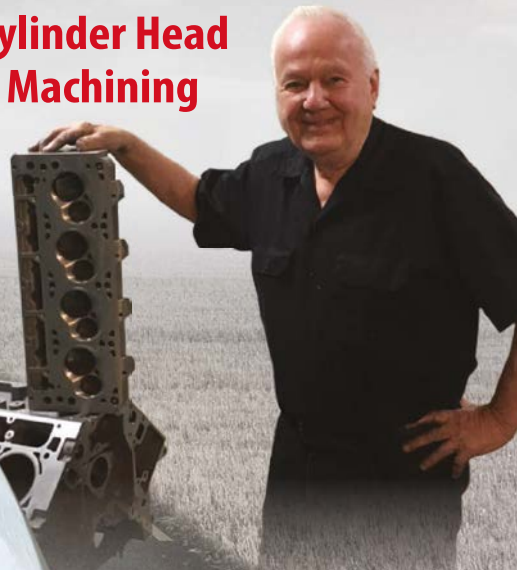

## Rottler CNC Engine Block Honing

*"We have spent countless hours using the Rottler CNC Vertical Honing Machine in the hunt for the proper surface finishes required to achieve perfect ring seal.*

*Until recently we have been limited to using vitrified or diamond abrasives.*

*The vitrified stones gave us nice clean cuts and make it easy to hit the target surface finish numbers but consumable costs are much higher compared to diamond stones.*

*Diamonds can create better bore geometry and give extremely long life but the surface finish is nowhere near as clean a cut and we see lots of debris and burnishing of cylinder surface.*

*After testing CBN abrasives from Ed Kiebler of Rottler, I was amazed at the surface texture, we now have the best of both worlds.*

*We have an abrasive with extremely long life and a surface finish that is as good as or better than the vitrified delivered. Little to no debris, no burnishing and almost thread like consistency in the valleys.*

*We've examined these different abrasives and the surface textures they leave under high power microscope and the results are consistently the same.*

*CBN honing stones are a real game changer."*

– Keith Jones, Total Seal Piston Rings



[www.rottermfg.com](http://www.rottermfg.com)

[www.youtube.com/rottermfg](http://www.youtube.com/rottermfg)

[www.facebook.com/rottermfg](http://www.facebook.com/rottermfg)

[contact@rottermfg.com](mailto:contact@rottermfg.com)

**ROTTLER**  
**THE CUTTING EDGE**

8029 South 200th Street

Kent, WA 98032 USA

+1 253 872 7050

**1-800-452-0534**

NOW AVAILABLE

# BOSCH MOTORSPORT M5 RACE ABS KIT

ORDER FROM MOTORSPORT SYSTEMS LTD.

PRICES  
FROM  
£5,091



## THIS KIT BOASTS A HOST OF IMPROVEMENTS INCLUDING:

- ✓ Enhanced brake performance with further developed ABS control algorithm (for example, corner braking)
- ✓ Calculation and display of optimal brake balance
- ✓ New ABS hardware for improved wheel slip control
- ✓ Extended variety of wheel speed sensors
- ✓ Improved system robustness due to cancellation of susceptible brake light input
- ✓ Diagnostics via CAN as driver information (for example, warning messages on driver display)
- ✓ Optimized performance and shortened braking distance through individual adjustment of slip with respect to downforce
- ✓ Only one software version for three hardware variants
- ✓ Hardwired wheel speed sensor signal output
- ✓ Enhanced MM5.1, 5 axis acceleration sensor, with yaw and roll rate included
- ✓ System can be configured to utilize incoming CAN message to change maps
- ✓ Front and rear brake pressures

## PRICED FROM:

**ABS M5 Kit Clubsport**  
F 02U V05 2919-01  
**£5,091.00**

**ABS M5 Kit**  
F 02U V05 289-01  
**£5,980.00**

**ABS M5 Kit  
Autosport Connectors**  
F 02U V05 290-01  
**£7,181.00**

All prices are subject to VAT.  
Prices valid until 31st December 2017.

## VIEW THE FULL TECHNICAL SPECIFICATIONS:

[www.motorsport-systems.co.uk/abs-m5-race-kit](http://www.motorsport-systems.co.uk/abs-m5-race-kit)



**MOTORSPORT**  
SYSTEMS

01684 291122  
[www.motorsport-systems.co.uk](http://www.motorsport-systems.co.uk)

# Reality EV

**With the imminent arrival of the second-generation racecar and new street circuits to master, simulators are rapidly becoming the must-have development tool in Formula E**

**T**he rise and rise of Formula E and its relevance in the development of electric vehicle technology is having a profound effect on the use of new engineering tools and practices in motorsport – in particular when it comes to driving simulators. Season 5 of the all-electric FIA series represents the biggest leap forward for FE with completely new second-generation cars, the addition of brand new tracks and the arrival of official manufacturer teams including BMW, Audi, Nissan, Porsche and Mercedes.

## New era

This is not without its unique challenges, though, as Dennis Marcus, commercial manager automotive and motorsport at simulator manufacturer Cruden, explains. 'With FE races taking place on street circuits there is virtually no time for teams to test the exact track and circuit outside of a race week. With the confirmation of several new circuits on the calendar for Season 5, teams are relying on simulators even more than before to test and validate their energy management strategy for a race. It is not just the tracks that are new, though, because the new car will now be capable of running a full race on a single charge.

'The races will now be time limited, which requires an entirely different strategy for energy management as the pace of the race is determined by the car leading the race, Marcus adds. 'A key factor is that the team cannot influence its car during the race. Even telemetry is delayed. Drivers are on their own and therefore pre-race development and preparation is essential. Engineers have to work with drivers to provide them with the best tools to manage the energy during the race.'

Teams such as Mahindra Racing employ a bespoke Formula E simulator for set-up development, race strategy and energy

**'Accurate modelling of battery energy flow and thermal behaviour are especially important for Formula E'**



Simulators have been helping the Formula E teams to come to terms with the new strategy challenges Season 5 will bring

management optimisation, development of control systems and driver training. The team's Cruden system comes with the proprietary Panthera simulator software, which allows Mahindra's new Gen2 vehicle model, which is also used for lap time simulation, to be integrated and used as a real-time driver-in-the-loop (DIL) simulation model. Furthermore, it has access to a full library of Formula E street circuits as Cruden produces accurate reproductions of all the tracks on the Season 5 calendar.

Marcus says: 'Cruden's involvement in Formula E is helping to accelerate the development of the simulators themselves. Through our partnerships, we have developed systems that offer the high quality visualisation and low latency that drivers need to control the car in the simulator as they do the real car. On motion-based platforms, the steering inputs and movements correlate directly with what's been shown on the screen. Engineers can programme

and fine-tune race parameters with extreme accuracy. Cruden also develops and supplies all elements of the simulator system, providing integration support of third party products like the vehicle model steering wheel and ECU.'

## Driver immersion

Dr David Batterbee, senior simulation and performance engineer, Mahindra Racing, says: 'One of the most important features of a high-performance racing simulator is driver immersion. For maximum benefit, the driver must perceive minimal difference between the simulator and the actual car. Important factors include having high quality graphics and visuals, providing accurate cues for understeer/oversteer/locking, having driver controls that provide the correct feedback (steering, brakes, throttle response, steering wheel controls), using a well-correlated vehicle and tyre model and having a high resolution track scan.

'Accurate modelling of battery energy flow and thermal behaviour are also especially important for Formula E,' Batterbee adds. 'Getting all these factors right maximises the performance that can be extracted from the simulator and ensures problems solved are equivalent to those experienced on track.'



# Easy rider

Lamborghini has launched a comprehensively upgraded Huracan GT3, the development of which has been deliberately focussed on making it user-friendly for gentleman drivers. Is this the perfect approach for a customer sport project?

By **ANDREW COTTON**

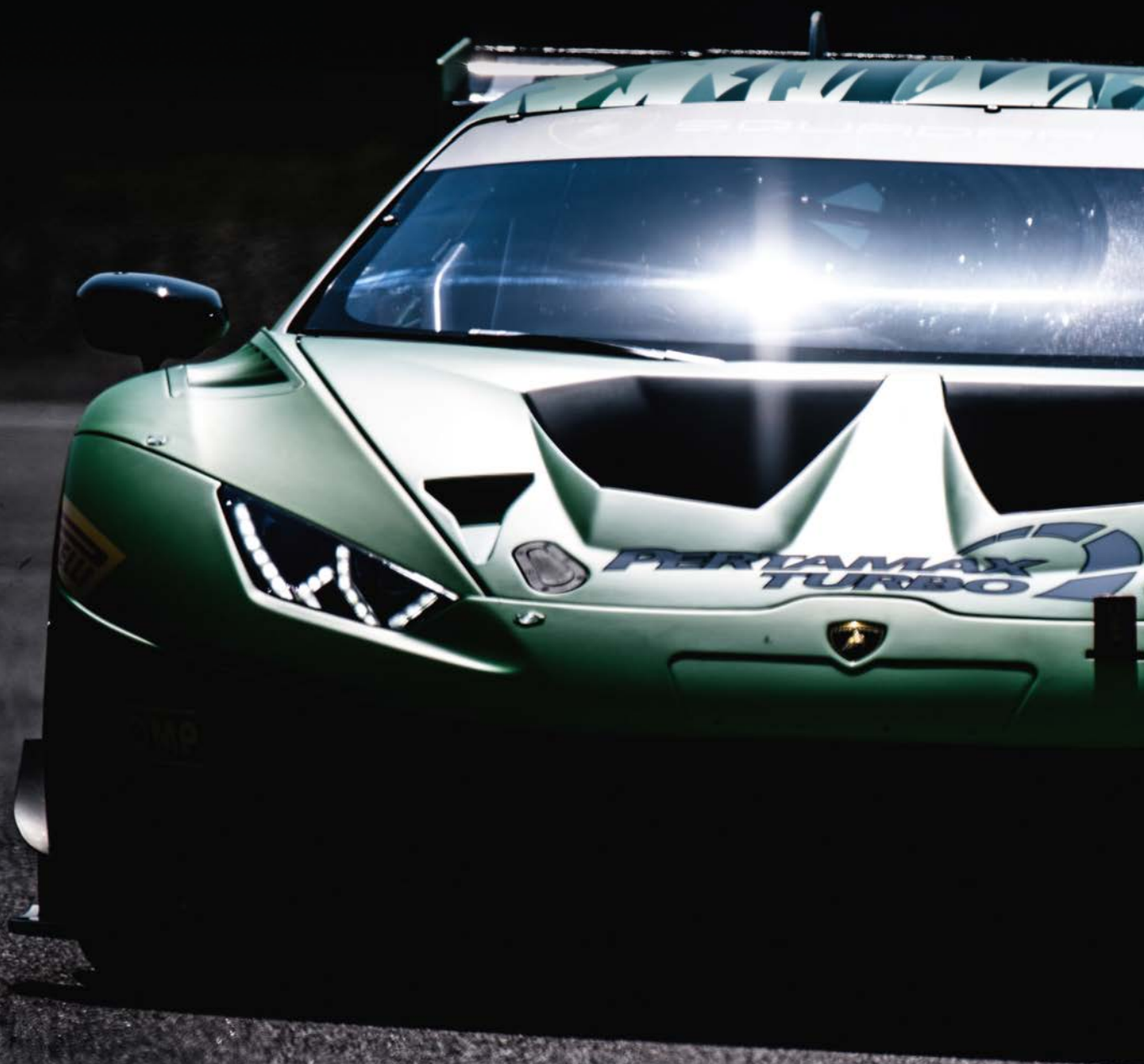

**GT3 cars today have to be versatile and meet more criteria than ever before**



**V**isually, the Lamborghini Huracan GT3 Evo features a small upgrade to the existing model, which was first introduced to GT3 racing in 2015. The current Huracan has already scored multiple race wins and won the Blancpain Series teams' title in 2017. Yet under the skin, the Evo is almost a new racecar. The Evo kit features a new roll cage, a new engine, a new rear suspension, as well as a revised driveshaft quick-change mechanism, a new power steering system and a new aero package that is designed to increase downforce, with only a slight drag penalty.

GT3 cars today have to be versatile and meet more criteria than ever before. With a global market, they have to be adjustable for different types of circuit (in the US, Europe and Asia), run with different tyres (Pirelli throughout most of the world, but there is also an open tyre choice in series such as the VLN), work over sprint races, such as the Blancpain Sprint Series with one-hour duration, and endurance, the longest being the Spa 24 hours.

### League of gentlemen

The cars also have to be driven by amateur drivers as well as professionals, and it is here that each of the manufacturers producing new cars, or evolution kits, has focused attention; an easier car to drive is better for all concerned, particularly in the long-distance races where changing track conditions, weather and simple fatigue can all contribute to a race-ending event. From a pure performance point of view, the pro-am series relies on the amateur driver to be able to lap as close as possible to the ultimate pace of the car, and it is here that Lamborghini has concentrated its efforts.

For example, the new power steering system is electro-hydraulic, and takes over from the purely hydraulic system that is in the current car, allowing drivers to choose the weight of the steering system according to preference.

'With the electric device we had the opportunity to change by multiple switch the servo assistance to the driver, so the next driver can have the option to have the steering light, medium or a bit harder,' says Leonardo Galante, technical responsible for motorsport at Lamborghini. 'It depends on his feeling. The current version has the pump attached to the engine, but this one is electro-hydraulic so EHPS,' continues Galante. 'Normally, as a manufacturer we do a lot of recommendations' →

for the teams, where the teams should work to optimise the performance, but for the more professional teams, if you give them something more sophisticated they can do something better. I am only worried that the non-professional team can make more of a mess if they don't use the manual that we provide.'

## Roll play

The change to the roll cage serves two functions; the horizontal bar on the driver side of the car has been lowered to allow drivers easier access to the cockpit; a vital performance tool when pit stops are 16 seconds long in the Sprint races, leaving the drivers just 15 seconds to change. It is a point that has cost the Grasser Racing team two wins this season as the drivers were not able to get their belts done up properly in this quick stop, and so were slow exiting the pits. Taller drivers also get more headroom, with a revised bubble in the roof. The previous car had a 'v' shape bubble, this Evo has an 'x' shape to allow more movement.

Safety is a top priority and the mandatory energy absorbing door foam has been introduced onto the Evo model, although the side intrusion panels are only mandatory on new cars, and not on this already existing car.

One of the key words in the new generation GT3 cars is 'driveability', and here Lamborghini has worked with Dallara in its 40 per cent wind tunnel to develop a car that is more predictable

in handling. 'We moved the aero balance plus 10 per cent to the front, so we worked on stability and pitch sensitivity, which means that when you have such aero, you have to create in the driver the feeling that even with car movement the aero position doesn't change too much,' says Galante. 'If you are braking, then the aero balance goes to the front, and if it goes too much, it goes light on the rear and that creates a distance from the axle. If you create the downforce and less pitch sensitivity, then you create a more predictable car. This was the principle. For stability, we optimised the car where you need downforce, so in cornering. In the wind tunnel you can put the car in rolling, steering and yawing, and we improved the downforce in this condition. When you pass from the straight to corner, the aero changes in a manner that the car is still predictable. This is involving the underfloor.'

The underfloor aero is now better fed by the flow through the front wheel arches. The nose of the car has been redesigned to channel air out through the side of the cockpit, helping to produce downforce. The front features significant modifications to the splitter, with a pronounced leading edge. The bonnet has also been modified, with carbon replacing fibreglass as the base material, and thanks to the large central rib borrowed from the Trofeo that was launched earlier this year, it has improved the cooling capacity of the radiators.

'With the front wheel arch design, we worked a lot on the strength of the material,' says Galante. 'We integrated a steel mesh, co-laminated with Kevlar and carbon to keep it strong. Often during races you pick up rubber, stones, and so on, and you can destroy [the bodywork] if you delaminate the tyre. ... This was a sort of weakness in the current car, and I think that we made a big step. The wheel arch is a component that represents the connection to the underfloor, so it is critical to air flow. The outer shape looks the same, but underneath it is

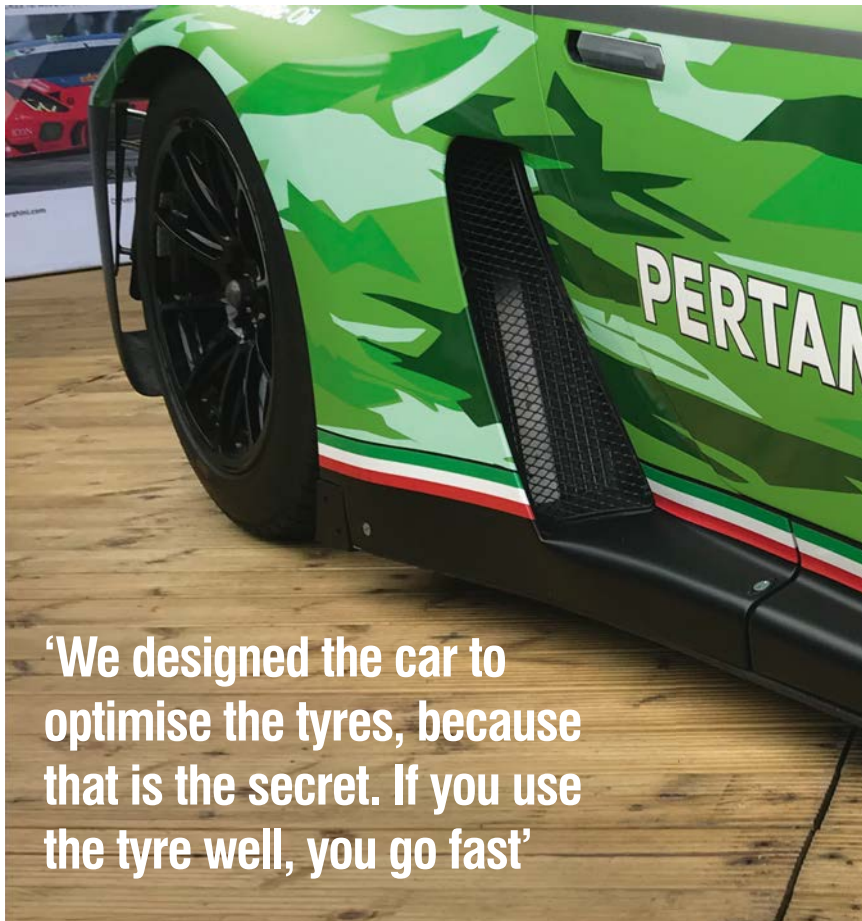

**'We designed the car to optimise the tyres, because that is the secret. If you use the tyre well, you go fast'**

Energy absorbing door foam has now been added to the Huracan but not side intrusion panels, as these are only mandatory on new cars. The car is already well-known for its ability to protect a driver in a big impact



The bonnet has been modified and is now of carbon fibre rather than fibreglass, while its shape has helped to improve the cooling



At the front braking is provided by Brembo 380x34mm discs, while the ABS is adjustable through 12 positions on the steering wheel



# CUTTING **EDGE** TECHNOLOGY

## PRECISION PERFORMANCE

Come see us in 2018 at  
**SEMA booth 23561**  
**PRI booth 4815**  
and in 2019 at  
**Autosport Engineering**  
**stand E530**



The PRO 5000 R offers you Radi-CAL™ brake caliper technology in an entry level range.

Forged designs, developed using our vast experience in motorsport, incorporate the latest innovations from our pioneering asymmetric design concept.

The Pro 5000 R range consists of ten 4-piston and three 6-piston options.

Fit AP Racing brakes and clutch systems for race success.

The science of friction

T: +44 (0) 24 7663 9595 E: [racetech@apracings.co.uk](mailto:racetech@apracings.co.uk) W: [www.apracings.com](http://www.apracings.com)

**AP**  
**RACING**

different. We pay for the increase in downforce with more drag, but it is a matter of balance in the car for BoP. The car was normally penalised on the high-speed tracks with a smaller restrictor but the drag was so low [that it worked].'

## Beefed up wing

One of the key changes was to the rear wing, which suffered in both stiffness and design on the existing model. Using engineering borrowed from the aerospace industry, a new and stronger wing design has been created. The wing has an internal structure similar to that of an aircraft wing, and features a twist in its leading edge to accommodate the different airflow around the side of the car and over the top.

'The previous wing had different technology and we had a little quality problem with this construction, so we improved the construction itself, which avoids aero elasticity, to [have] the downforce and stability where you want', says Galante. 'The shape of the wing is different. There is a small leading edge, and the airflow from the outside of the car comes at zero degrees, and the flow over the roof is angled, so if you want to keep the relative angle of the wing constant, [there is a twist in the wing]. It is a small thing, but a wing like this compared to the previous wing is more efficient.'

The wing mountings feature the now-standard swan neck design. 'If you put the mounting under the wing, it is more sensible

because there is suction here, but if you have flow detachment you lose a lot,' says Galante. 'Here [on top of the wing] you have a compression area, but you always have compression, so it is more predictable and you can use the lower part of the wing that is responsible for 60-70 per cent of total downforce.'

The suspension system has also been a key area of development. The Lamborghini, like the Audi R8, had to run with a high static camber in order to generate the performance required, and in 2017 that led to more loading on the inner shoulder of the tyre, and delaminations. Pirelli produced the D2 tyre to cater for this characteristic, but Lamborghini has now addressed its issue. It has introduced four-way adjustable Ohlins dampers to help with the stability of the car, particularly after kerb strikes, and the front wishbones are now made from billet aluminium rather than steel.

'The wishbones are beautiful, and also cheaper because we found the right technology to produce them cheaply which is good for the running cost of the car,' Galante says. 'We focused attention on the front kinematics of the car, to create more connection from front to rear' ➔



## TECH SPEC: Lamborghini Huracan GT3

### Chassis

Aluminium and carbon fibre hybrid.

### Body

Carbon composite external panels.

### Aerodynamics

Manually adjustable rear wing.



### Engine

10-cylinder; 90deg V angle; naturally aspirated; gasoline direct injection IDS; dry sump lubrication. Displacement: 5.2-litre. Bore and stroke 84.5mm x 92.9mm. Compression ratio 17.7:1. ECU and TCU management: Bosch Motorsport MS6.4.

### Transmission

Rear-wheel drive with mechanical differential lock; traction control by Bosch Motorsport, adjustable in 10 positions through the steering wheel. Gearbox: Hor 6-speed sequential, pneumatically controlled.

### Suspension

Front and rear: double wishbones with uniball. Dampers: 4-way Ohlin TTX 36. Anti-roll bar: front and rear, 3-way adjustable.

### Safety equipment

FIA spec roll cage; carbon fibre racing seat  
FIA 8862 spec; roof hatch system.

### Wheels

Front: 12x18in ET45.65. Rear: 13x18in ET37.85.

### Tyres

Pirelli P Zero. Front: 325/680-18. Rear: 325/705-18

### Brakes

Front: Brembo steel brakes; TM Racing 380x34mm discs; 6-piston monobloc caliper. Rear: Brembo steel brakes; TM Racing 355x32mm discs; 4-piston monobloc caliper. ABS: Bosch Motorsport M5, adjustable in 12 positions through the steering wheel.

### Fuel tank

120 litres, FT3 spec.

### Dimensions

Length: 4551mm. Width: 2221mm (mirrors included). Wheelbase: 2648mm. Front track: 1700mm. Rear track 1660mm.

### Weight

Dry weight: 1230kg.

The 5.2-litre V10 has new camshafts and titanium valves. Its torque curve has been modified to suit gentleman racers

# Lamborghini has worked with Dallara in its 40 per cent wind tunnel to help develop a racecar that is more predictable in its handling

# Performance focused engine components



For over 40 years we've been manufacturing performance focused engine components. Our British made quality means you'll find us at the heart of the world's most powerful engines.

**Call us +44 1455 234 200**

Exhibiting at:

**Professional  
MotorSport**  
WORLD EXPO 2018

**PRI**  
DECEMBER 6-8, 2018  
INDIANAPOLIS, IN • USA

**AUTOSPORT**  
INTERNATIONAL  
ENGINEERING  
SHOW

OVER 40 YEARS OF  
BRITISH ENGINEERING



© Arrow Precision Engineering Ltd Est.1974

Discover innovation at  
[arrowprecision.com](http://arrowprecision.com)



Lamborghini has improved the aerodynamics, albeit with a slight drag penalty. While there is little evidence of this work on the upper bodywork of the car, the underfloor has received plenty of attention. Note the Hor gearbox between the exhausts

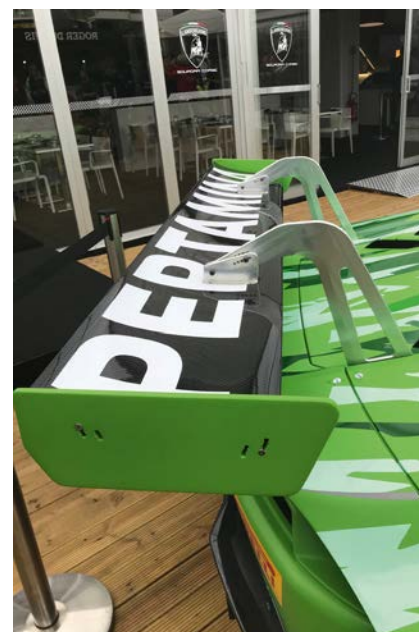

The new swan neck-mounted rear wing features a twist in its leading edge to deal with the different types of airflow from the car's sides and its roof

axle. At the rear, we made a lot of effort to create a new hub, and the driveshaft goes inside with tripods and a more kinetic CV joint and so it is more efficient and easier to maintain.'

The driveshaft can also be dismantled so that teams can better understand it and what is happening to it. 'The previous one was one piece, and you just put a new one in, but now there is the possibility for the teams to see inside the components which is much nicer,' says Galante. 'For the endurance races, we changed the mounting points of the hub with the bearing, so if you have some problem with the driveshaft you can extract everything. Five bolts and the whole driveshaft comes off without touching the suspension. The mounting points at the rear we have changed on the wheel side, so we wanted to increase the camber gain, and change the kinematics at the rear. We designed the car to optimise the tyres, because that is the secret. If you use the tyre well, you go fast. The problem with a high static camber is, on

the straight you load the inner shoulder of the tyre and start to delaminate. If you start with less static camber, you gain a lot when you are cornering and you gain on the straight.'

## Heart of the matter

The engine is the 5.2-litre V10 derived from the latest generation of road going Huracan, which adopts new camshafts and titanium valves to optimise driveability and provide greater reliability in endurance races. 'This engine has new heads, and titanium valves which are much lighter, and the valve train can go more efficiently and faster, and the new camshaft profile results in 1mm higher lift in the valve,' says Galante. 'So, we redesigned the calibration of the engine and we have a completely new output and torque curve, in a way that the car is now more on the lower RPM, so that the gentleman driver, when they push the pedal, they feel the power. Compression ratio is the same. We don't touch the engine from the road

car, but in this new engine the main difference is the heads, not the crankcase.'

Testing has been on-going since March, and the team's already put more than 20,000km on the car, ahead of its race debut at the Daytona 24 hours in January.

'The main objective during development was to improve driveability, making the car easier and more predictable for gentlemen drivers, with low management costs for the teams,' says Giorgio Sanna, head of Lamborghini Motorsport. 'For teams that have invested in Lamborghini in the GT competitions of the past, we offer the opportunity to update the current Huracan GT3s with an evo kit homologated for the next three years of competition.'

The update kit is in the region of €90,000, while the full car will cost €389,000 plus tax. Since 2015, Lamborghini has sold 75 GT3s cars, which is considered a successful programme for a manufacturer with relatively little experience in customer motor sport.



The team has already put more than 20,000km on the car ahead of its race debut at the Daytona 24 hours in January

# we share your passion



**On-Track Accident Damage Cover**  
**Motorsport Commercial & Liability**  
**Road Insurance for Competition, Sports,**  
**High Performance & Modified Cars**  
**Insurance for Event Organisers**  
**Personal Accident & Travel**

**0115 965 1020**

On-Track Accident Damage  
Motorsport Vehicles,  
Competition and Sports Cars

**0115 965 1050**

Commercial Policies,  
Liability Cover and  
Personal Accident



[www.reis.co.uk](http://www.reis.co.uk)  
[talk2us@reis.co.uk](mailto:talk2us@reis.co.uk)

Reis Motorsport Insurance is a trading name of Insurance Factory Limited.  
Insurance Factory Limited is authorised and regulated by the Financial Conduct Authority (No. 306164).  
Registered Office: 45 Westerham Road, Sevenoaks, Kent TN13 2QB.



# Pole positions

If you want to know what it's really like to work in professional racing and, more importantly, how to clinch your own dream job in motorsport, then you need to talk to those on the front-line. *Racecar* did just that

By **GEMMA HATTON**

In professional motorsport every racecar requires a team of full-time engineers who dedicate their lives to maximising its performance. But how many engineers make up a team? What does each of them do? How does this improve the performance? Not many know the answer to all these questions and, unfortunately, this lack of insight into the inner workings of race teams, particularly in the trackside environment, is the reason why motorsport is facing a huge shortage of quality engineering talent.

It's by no means a new problem, either. 'I had no exposure to motorsport growing up,' says Bernadette Collins, who is senior strategist at Racing Point Force India. 'The TV coverage at the time was very focused on the drivers and the cars and not so much on the engineers working on the pit wall, or the mechanics working in the garage, so I was unaware that those jobs



Getting this many people to achieve a 2.5s pit stop requires teamwork of the highest order. The ability to work in a team is a fundamental attribute if you are after a job in motorsport

## 'When you are instructing your race drivers or mechanics there has to be absolutely no doubt in your voice'

Trackside, the engineering ladder usually starts with a data or performance engineer who ensures that all sensors are recording reliable data, which is then analysed to advise the race engineers on potential areas of improvement.

### Race engineers

Race engineers sit on the next rung of the ladder and are the link between the team in the garage and the driver out on track. Not only are they responsible for managing and working with the drivers to get the best out of them, but they also work with the mechanics, tyre and strategy engineers as well as the suppliers, absorbing as much information, data and feedback as possible to converge on the optimum set-up changes for their racecar.

'There is a general misconception of what a race engineer's position is,' says Leena Gade, three-time Le Mans-winning race engineer.

'Really, you're just another engineer on the team who just happens to have a lot more responsibility because you are in charge of the whole car as opposed to one component.'

And that responsibility means making decisions. 'In endurance racing, what you decide to do at the pit stops dictates how much time you've lost in the pits and you therefore have to try and balance that off later in the race,' Gade says. 'When you make that decision, sometimes you are basing that on only having 80 per cent of the information, but when you are instructing your drivers or mechanics there has to be absolutely no doubt in your voice. Even if you think your decision is wrong, a decision that is wrong is better than no decision at all. Everyone is a good quarterback on the Monday after the race, but in the heat of the moment if you are not confident about your decision, watch what happens at the pit stop – it will be utter chaos. ➔'

even existed. I just never considered that it takes a team of engineers to run a racecar and no one explained to me that those engineers had probably done a mechanical engineering degree. I didn't study mechanical engineering to get a job in Formula 1, I studied it because I really enjoyed maths, physics and technology, as well as the more practical aspects.'

### Quick work

There are approximately 80,000 components in a modern Formula 1 car and each one of these components requires engineers to design, simulate, test, manufacture and optimise it to achieve the highest performance. Then you have the trackside engineers who are responsible for exploiting this performance at the circuit through analysing data and tuning the characteristics of these parts to the desired set-up for that particular track, car and driver.



Race engineers are responsible for optimising the performance of both the car and the driver and the only way to become one is to gain experience in the lower formulae. Leena Gade (left) started her successful career helping out in Formula Vee

# ‘Motorsport is a culture, a lifestyle, it is an environment in its own right and you have to be in it to really know if you like it or not’

You have to be quite tough skinned and there is always going to be times where you get it wrong. But afterwards, if you can be pragmatic about it and analyse the areas of improvement, then you can fix it ready for the next race.’

## The bosses

Then there are the chief race engineers, the technical directors and/or the team principals who oversee the engineering of both cars as well as the entire trackside operation and are the only ones who can overrule the race engineer’s decisions. Depending on the size of the team there will also be engineers responsible for strategy, tyres, control systems, aero, reliability and electronics, who not only feedback to the race engineers at the track, but also their corresponding departments back at the factory.

‘Before the event we have two days at the factory where we do as much prep work as we can, so we try and determine which tyre compounds we are going to use and in which session,’ says Collins. ‘We try to pre-empt what the degradation, pace and therefore race strategy is going to be like based on historical data to give our drivers an idea so that they can then drive accordingly. Throughout the weekend we then try to manage the sessions and take as much information as we can from our car but also from across the field.’

‘Going into the race we try to plan a strategy for every eventuality, whether that be weather conditions, crashes or safety cars,’ Collins adds. ‘While during the race it’s about being in a position where we’ve done all the background work so we are ready to react to the ever-

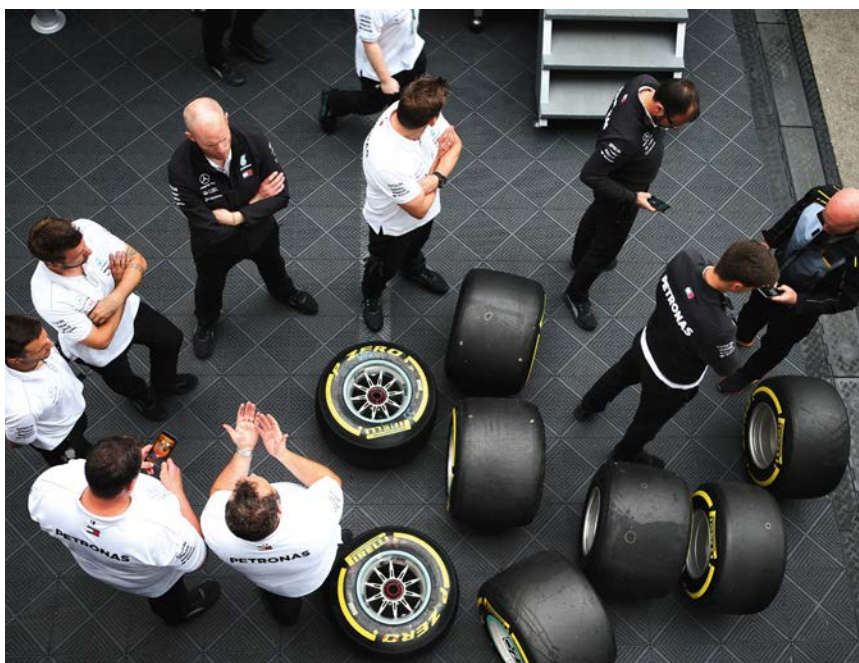

Trackside jobs do not stop with the race teams and another route into high-end motorsport is working for the suppliers – tyres, brakes, oils, lubricants and many others – that are an essential part of the racing scene

changing situations and hopefully stop on the right lap and change to the right tyres. I then spend the entire week after the race analysing our performance and comparing that to other teams to determine if and how we could have done better and what we need to learn so that hopefully feeds forward to the next race. Then the whole process begins again.

A group of trackside engineers who are less well known are those of the suppliers and partners. Whether they manufacture brakes,

tyres, transmissions, electronics, oils, engines or radios, each supplier will send representatives trackside to help teams utilise their products.

‘Being on the engine side you get to work with both the mechanics and engineers of both cars and I enjoy that diversity,’ says Margarita Torres Diez, F1 power unit engineer for Mercedes-AMG HPP, who is currently responsible for the running of Valtteri Bottas’ power unit. ‘Friday is the first time the engines are run properly during the race weekend, apart from a few fire ups on Thursday. My job is to ensure that we can extract the maximum performance out of the engine and sort out any issues. We spend many hours analysing the data and sending reports back to the factory and then set up the calibrations for the weekend.’

‘During the sessions I am mainly checking all the temperatures, the energy deployment, ensuring we are within our pre-determined limits as well as making sure that the driver is in the right engine setting,’ Torres Diez continues. ‘The current V6 engines are a lot more complicated than the previous V8s, but that means they are also a lot more interesting too, so it is always a new challenge.’

## Home work

Of course, it’s not just the trackside environment that can offer you a thrilling and fulfilling engineering career. The factories of race teams, suppliers and manufacturers are all hives of activity, filled with engineers who spend their days delving into the finite detail of designing,



Working in motorsport will give you a lifestyle that’s unlike most other occupations. To survive the long hours at the track and being many miles from home you have to be passionate about it. You also need to understand that you are a part of a team



# First sensors infra red arrays **RED** range



Clutch temperature sensor, 8 pixel array, 16 pixel array, 1350 C Brake sensor, 32 pixel array, 80 pixel array

## Featuring

- Updated low power electronics
- Reverse protection
- Programmable CAN ID
- Programmable distance calibration
- Programmable emissivity
- Super wide angle version for closed wheel cars and bikes
- Thermal software protection

For more information please go to  
[www.firstsensors.com](http://www.firstsensors.com)  
or call 01379 642 444

First sensors IR range are designed to measure the temperature across a tyre and single spot temperatures for brakes and clutches.

The tyre range has been designed to meet the needs of open and closed wheel racing cars with new super wide angle sensor (8 and 16 pixel arrays).

The sensors are programmable and can be used with our IR sensor android application for easy programming. Brake sensor and clutch sensor are now fitted with thermal protection which allows the sensor to handle higher ambient temperatures without damage to the sensor. Thermal management software shuts down the sensor so the electronics can not get damage by excessive over temperature.





Arguably the most pressurised of all trackside jobs are those on the pit wall, because decisions need to be made live during the race – but the adrenaline rush can become addictive

making and optimising complex parts. 'My main responsibility is the aerodynamic development of the LMP1 car from the very first concept right through to the finished racecar,' says Silvia Santarelli, senior CFD engineer at Toyota Motorsport. 'Of course, my main goal is to maximise the performance of the car through improving the aero efficiency. I mainly use CFD to design the shape of the parts, run simulations and then analyse the results and then work closely with the wind tunnel engineers to try and obtain the best performance. I have the opportunity to work on many different areas of the car, whether that be the low or high downforce bodykit.'

'We have a lot of freedom to be creative because you always need to do something new to try and improve to beat the competition,' Santarelli adds. 'I get a huge sense of satisfaction and pride when I see a part on the real car which I have designed, it is extremely rewarding.'

## The lifestyle

But what is it *really* like working in motorsport? 'Motorsport is a culture, a lifestyle, it's an environment in its own right and you have to be in it to really know if you like it or not,' says Gade. 'It's great thinking it's glamorous, or that race

engineers are gods with a sixth sense for setting up racecars, but that doesn't exist. It's about hard work in an environment that is alien to a lot of other industries, educations and people. I think people assume it's really easy but it isn't. You have to learn that in racing it's all about everything working together. Yes, you may need one or two people to pull it all together but you need everyone to be on the same wavelength and thinking in the same way.'

'It's easy to agree things as a group, but it's a whole other thing to take a command or give a responsibility to someone without questioning them,' Gade adds. 'Success or failure is never down to one person and I get hugely frustrated when people say "you won Le Mans". No I didn't, my team won Le Mans and I happened to be part of that group. Your team always comes first, otherwise you will be unemployed, then it's your car crew and then your ego if it even gets a look in. There were weekends where we were better than most, but I can guarantee that there was always something we needed to fix, but that's what I like about motorsport; there is always that challenge to win, or win again.'

'Then there will be other weekends that are just horrendous from start to finish and it becomes a downward spiral which you have

to try and stay on top of otherwise it becomes uncontrollable. Those weekends are actually where you learn the most, not just about the car or yourself, but also about people's personalities and how that affects your team.'

Arguably the most pressurised motorsport jobs are those on the pit wall, where decisions are made live, during the race, and need to be right. 'Equally those are the jobs with the most instantaneous reward and that does become almost addictive,' says Collins. 'The adrenaline, the extreme peaks of pressure and focus really gets your heart going, which is something you don't often get back at the factory. Everything is sort of amplified at the track. Of course that makes it tougher, you lose more weekends and work longer hours, but that rewarding feeling of achieving a good result is worth it.'

## Getting started

Of course, the chills and thrills of working on the pit wall of a race team can often seem in another galaxy compared to you sitting on the sofa watching the race on TV. But in truth, it is much closer than you think. You just have to be proactive, ready for a challenge, and first of all become a weekend warrior. 'I started out making cups of tea for a Formula Vee team,' says

**'Your team always comes first, otherwise you will be unemployed'**



# Innovation Experience

HIGH PRECISION CNC MACHINING &  
WINDFORM ADDITIVE MANUFACTURING

Automotive application, combination of Windform Additive Manufacturing and high-performing CNC Machining.  
Courtesy of Ilmor Engineering



**CELEBRATING OVER 45 YEARS OF PRODUCING EXCELLENCE**

Our Italian craftsmanship and professional skills make us the choice partner in gaining technical advantages in **High Precision CNC Machining** and **Advanced 3D Printing Service** that few others can guarantee.

Producing quality, reliability, innovative solutions and speedy delivery service are our distinguished features.



[www.crp-group.com](http://www.crp-group.com)

LONG-STANDING EXPERIENCE

[info@crp-group.com](mailto:info@crp-group.com)

Gade. 'We would clean and fix the cars, replace gearboxes and lift the engines out and I didn't care because I was getting my hands dirty, I was involved in motorsport and I was learning. That set me up for a Formula BMW team who needed someone to download the data from the car, and of course then I ended up analysing this data and becoming their data engineer. I wasn't being paid for anything, it was voluntary on my weekends, but those were the weekends I learnt the most. I had zero intention of becoming a race engineer when I went to Audi, I went in as an engineering assistant and then one thing led to another and, all of a sudden, I was race engineering Audi's only surviving car, 10 hours into Le Mans in 2011!'

**Helping out**

Getting yourself to race tracks, introducing yourself to race teams and offering to work for free – even if it means cleaning wheels to start with – is the only way to make it in motorsport. Not only does this improve your knowledge, but it gets you moving in the circles of racing; making those all important contacts.

Engineering degrees from highly regarded universities have become an expected and expensive formality to get you through the doors of HR. But no longer is achieving a first-class degree good enough to make you stand out from the crowd. Not even taking part in

**'The adrenaline, the extreme peaks of pressure and focus, really gets your heart going'**

Formula Student warrants a cheer anymore, because it is already the norm. You need to have *real* motorsport experience.

'I completed my degree and got a place on McLaren's graduate scheme. But alongside that I gave up my weekends to do data and then race engineering for one of the GTE teams,' says Collins. 'I also got involved with race support in mission control during the F1 races, just helping with reports to try and integrate myself within the team. I then got the opportunity to stand in for one of the performance engineers in 2013 and became a full-time performance engineer in 2014 before I moved to Force India to take up my current role as a strategy engineer.'

**The right stuff**

Getting involved at your local circuit doesn't necessarily have to be as part of a race team. There are many other roles that can gain you invaluable experience to help you get your foot in the door. 'When I was 18 I got my license to be a marshal for my local race track and so marshalled the pit exit position for one year,' says Torres Diez. 'I then did my license to be

a scrutineer, and then I became technical scrutineer for four years, and then I was a technical delegate of the Spanish Rally Gravel Championship for the Spanish Federation.'

Degrees, experience, contacts are not the only ingredients you need to succeed. You also need to believe. Motorsport is an industry that thrives on competition, and there will be times where you fail that interview, or lose that lap of data, and you will probably get rejected by almost every team you apply to. But it only takes one 'yes' to begin your motorsport career.

'My 10-year old self would never have imagined that I could have this position in Formula 1 and I maybe should have had a little more confidence in my ability,' says Collins. 'I just felt that my background was so far away from motorsport that I didn't realise it was really an option for me and I should have had more self belief to just go for it.'

The message is: no matter what your background is, how old you are, or whether you are male or female, never give up – because if you want to work in motorsport enough, then you will find a way to get there. 



**ENTERTAINMENT AND ENERGY-EFFICIENT MOTORSPORT CONFERENCE 2019**  
*Exploring the future of race-bred innovation*

AT



SHOWCASE YOUR TECHNOLOGY

ATTEND AS A DELEGATE

**THE WORLD'S LEADING CONFERENCE FOR HIGH PERFORMANCE ENERGY EFFICIENCY AND MOTORSPORT**

WEDNESDAY 9TH JANUARY 2019  
AUTOSPORT INTERNATIONAL • NEC, BIRMINGHAM



**PANEL DISCUSSION**  
Unique insight from international thought-leaders spanning motorsport, automotive and beyond



**NETWORK**  
200+ high-level industry, government and media representatives from across the globe



**SHOWCASE**  
Stunning display of over 20 cutting-edge high performance vehicles and technologies

**PRICING**

**Showcase Display**  
(incl. 2 delegates, lunch & refreshments) from £600 + VAT

**Single Delegate**  
(incl. lunch & refreshments) from £175 + VAT

**Explore The future of energy efficiency in motorsport**

To secure your place contact Sharon Ford on:  
**t: +44 (0)2476 692 600 or e: sharon.ford@the-mia.com**

**www.the-mia.com**

MEDIA PARTNERS







Rinehart Motion Systems, LLC



## Unleash Your Current Potential



**Bespoke:** From 3KW to 1MW. Racing & Commercial solutions with leading technology in GaN / SiC / IGBT / FET technology

**PM-Series:** Light-weight and high-performance from 100KW to 250KW, available with short-lead time for Motorsport, Supercars, Small Series Production

**RM-Series:** Now with production capacity in place for our 2018 Automotive and Heavy-duty volume product line, ranging from 100KW to 300KW



PROPELLING INNOVATION in ELECTRIC PROPULSION

[www.rinehartmotion.com](http://www.rinehartmotion.com)

Rinehart Motion Systems LLC  
7929 SW Burns Way, Suite F,  
Wilsonville, OR 97070 USA

**DISCOVER NEW**

# TECHNOLOGY. IDEAS. BUSINESS.

**DECEMBER 6-8, 2018  
INDIANAPOLIS, INDIANA USA**

The PRI Trade Show provides direct access to the latest in motorsports products, technology and business opportunities from around the world. If you're in the business of racing you can't afford to miss this event.

- **ALL FORMS OF AUTO RACING**
- **OVER 1100 EXHIBITING COMPANIES**
- **THIS IS A TRADE-ONLY EVENT**



LEARN MORE AT [PRI2018.COM](http://PRI2018.COM)

**PRI**

THE BUSINESS OF RACING STARTS HERE!

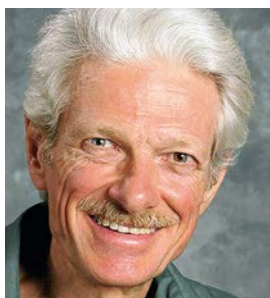

# How to nail spring and anti-roll bar selection

Why you must never set up a racecar without examining all the factors



The questioner evolved his own method of setting up a car's suspension by watching Lotus Cortinas cornering hard in the 1960s. This example is pictured more recently at Goodwood

**Q** I have surfaced a problem while I was working out the roll moment to determine the springs needed, and to relate the roll centre position with my understanding of what is happening. Having seen Jim Clark three-wheeling the Lotus Cortina and knowing the suspension geometry, I put the two together: a head-on photo with the suspension geometry constructed onto it to determine the dynamic rc position. I then made a tracing of the car and, using a pin, determined the point about which the car was rolling. Lo and behold, the constructed rc and the actual rc did not coincide.

I do realise that the text book rc is in fact a force centre but all the books use it as a pivot for the roll moment. Allied to the fact that the centre of gravity is only an estimate,

the actual roll moment arm cannot be determined. For years the standard practice has been to test the car and keep changing springs until a compromise is found. I carried on the photo idea with more cars of known geometry (and not three-wheeling) and the result was always the same: the actual and theoretical rc did not coincide.

To avoid this expensive changing springs (guessing), I synthesised the idea, from a few books, of balancing the front and rear suspension frequencies. It works. I've now done quite a few cars – two complete designs and some mods – and it works every time, straight off the drawing board.

I have a discussion with the client and determine exactly what he wants the car to do – race, track day, go to the pub, etc. I fit this into a graph to extract the frequency needed (limo 40cpm [cycles per minute]

aero race 180cpm) and work backwards to obtain the spring rates needed to give the desired handling and cornering.

The question is this: am I right or have I missed something here?

## THE CONSULTANT

**A** You have missed quite a bit, but you have at least two pieces of the puzzle right. First, roll centres are not true centres of rotation, as you say. That doesn't mean they are irrelevant, if properly understood. How to understand and assign them is a subject for an entire article. Briefly, I tell people to think of a roll centre as a roller in a vertical slot, not a pin in a hole.

Second, we can do better than a wild guess when selecting springs, and it is definitely sound to match undamped natural frequencies to the use of the car. However,



**It is definitely correct to match undamped frequencies to the use of the car**

# It really should be obvious that it's impossible to optimise a car's set-up or design for handling by simply working with one single aspect of it

that does not mean they should be the same front and rear, if that's what balancing them means, and it does not mean that there is any way of selecting them that can be relied upon to produce good handling across a wide variety of vehicles. Good ride, yes; good handling, no.

Indeed, it really should be obvious that there is no way to optimise a car's set-up or design for handling by working with just one aspect of it. All aspects of the set-up affect the handling: springing (including interconnective springs such as anti-roll bars, which do not affect natural frequency in ride); geometric roll resistance, which roll centres, properly assigned, are a measure of; geometric pitch resistance; unsprung load transfer, which can be as much as 25 per cent or more of total load transfer in live axle rear suspensions; aero forces; frictional effects, including damper properties; tyre sizes and other tyre properties; camber control; bump and roll steer; and many other factors, including bump stops, differential properties, binds, compliances, and also the driver's inputs and preferences.

## Package delivery

It's a long list, and since all of these have effects, it is the combination of all of them – the total package – that produces the car's handling properties. There is no reliable way to optimise the car by optimising just one aspect of the set-up without regard to the rest, or even by optimising all aspects but one. Yet there is no shortage of self-proclaimed gurus who

claim to have found a magic elixir that will do just that, and they all claim success with actual cars, despite the fact that their panaceas or short cuts are all different.

Chassis engineering is by no means unique in this regard. Medicine, theology, and politics are subject to similar vicissitudes. Among really ignorant people, even bizarre theories about the shape of the earth are shockingly common. But things could be worse. Life could provide us with nothing to puzzle over.

As Einstein said, everything should be made as simple as possible – but not any simpler. We cannot reliably produce good cornering balance or a desirable understeer gradient simply by selecting springs, or sprung mass undamped natural frequencies in ride or two-wheel heave. However, we can reliably get a level of general firmness that is appropriate for the intended use by choosing natural frequencies in the right range, and we can get a relatively flat ride by having a suitable relationship between the front and rear frequencies. We can use a nomograph, as the questioner does, or we can divide 188 by the square root of the static deflection in inches, or 947 by the square root of the static deflection in millimetres, to get the undamped natural frequency in cycles per minute (cpm). To express this in hertz (cycles per second), we just divide by 60. We can algebraically solve for any of the related quantities if we know the others.

The questioner is correct that 40cpm (0.67Hz; about 22 inches or 550mm static

deflection) would be appropriate for a limo, and 180cpm (3.0Hz; about one inch or 25mm static deflection) or even greater will suit a racecar with serious downforce. Comfortable family cars will fall in the 60 to 85cpm range (1.0 to 1.4Hz; about 10 to 5in or 250 to 125mm static deflection). More sporting road cars will be in the 90 to 120cpm range (1.5 to 2.0Hz; about four to 2.5 inches or 100 to 60mm static deflection). Racing cars without lots of downforce can be in this range too, or stiffer if the track surface is smooth.

It is possible to run frequencies as high as 180cpm on the street if styling considerations or other constraints demand very limited wheel travel, but there will be a penalty in ride and road-holding. Dirt track, gravel, and off-road applications require much lower frequencies.

## Frequency balance

The best relationship of front and rear sprung mass undamped natural frequencies is to have the front frequency about 90 per cent of the rear in a typical loading condition. It is also desirable to keep the front from being more than 95 per cent of the rear in any loading condition. This minimises pitch on the second bounce after the front and rear axles are sequentially displaced, as when going over a raised railroad crossing. On the initial bounce, the front is displaced before the rear. On the second bounce, we want the rear to take less time to bounce again, and roughly catch up with the front. That makes the front and rear go up and down synchronously rather than oppositionally, minimising pitch. Further bounces are hopefully largely damped out. With stiff damping, even the second bounce may be of relatively small amplitude, but even in racecars there is generally some road holding and comfort benefit to having the front frequency lower than the rear.

Second best relationship is to have the front frequency considerably higher than the rear – say, at least 30 per cent higher. This is a reasonable option for markedly tail-heavy cars or ones where front suspension motion needs to be severely limited for aerodynamic reasons.

We want to avoid having the front and rear frequencies the same, or the rear just a bit lower. That leads to a pitchy ride, although this will be less noticeable with stiff damping.

Suppose we have an existing car where the suspension and tyres already exist, or have already been designed or chosen, and we want to make an initial choice of springs and anti-roll bars. What method would I recommend?

To reduce it to the bare bones: 1. Decide on a range of natural frequencies, based on intended use of the car and any other



While 180cpm or even greater will suit racecars with proper downforce, off-road applications require much lower frequencies



necessary design constraints. 2. Choose frequencies within that range for flat ride, per above. Select available springs that will get you close to those frequencies with the motion ratios the car has. 3. From there, get the cornering balance or understeer gradient desired, and reduce roll gradient at the same time, using anti-roll bars, not springs.

## Roll bar selection

It's also possible to select anti-roll bars by calculation and get pretty close to right on the first try. That does take a bit more engineering than selecting springs, but you don't need an expensive computer programme or five semesters of college maths. You do need approximate values for sprung mass cg location, roll centre heights, unsprung mass weights, and anticipated lateral acceleration. The lateral acceleration value can be based on what similar vehicles do on similar tyres, or you can just use  $1g$ , which will give you your roll gradient in degrees per  $g$  and your load transfer values in pounds or Newtons or per cent per  $g$ .

First, estimate how much total load transfer is going to occur. This is simply total car mass times lateral acceleration, times overall cg height, divided by track. Decide how you want to apportion this, front to rear. If the car has 50 per cent rear weight and equal tyre sizes all around, and roughly comparable camber control front and rear, try to get close to equal load transfer at both ends. If the car is nose-heavy or tail-heavy but also has unequal tyre sizes such that the rubber is apportioned the same way the weight is, try for equal percentile load transfer at each end. When the car is nose-heavy or tail-heavy, and the front and rear tyres are equal size, as with most front-drive cars and older rear-engine cars, it is necessary to have a disproportionately large share of the lateral load transfer at the light end. How severe this should be is usually a guess, but we try to make it an intelligent guess.

Next, figure out what load transfers and roll angle you'd have with no anti-roll bars. You have to estimate the unsprung load transfer. That's cg height of effective unsprung mass for

**Even in racecars there is generally some road holding and comfort benefit to be gained from having the front frequency lower than the rear**



With older rear engine cars it is necessary to have a disproportionately large share of the lateral load transfer at the front end

lateral force at each end of the car, times weight of this, times lateral acceleration in  $g$ , divided by track. You have to estimate geometric load transfer. That's roll centre height, times sprung mass weight at that end of the car, times lateral acceleration in  $g$ , divided by track. Since we're assuming steady state, we can ignore frictional anti-roll or pro-roll (anti-de-roll) moments.

We add unsprung and geometric load transfers, and subtract that total from the total load transfer. The resulting difference is the elastic load transfer. Assuming there is an equal track at both ends, this will be apportioned in proportion to the elastic angular roll stiffness at each end of the car.

## Elastic roll stiffness

We are going to solve for required values for these, and then choose anti-roll bars accordingly. The roll displacement will be equal to the sprung mass elastic roll moment (total overturning moment, minus the total of unsprung and geometric moments) divided by the combined front and rear angular elastic roll stiffness. So we calculate what angular elastic roll stiffness we get from just the springs, and then, without changing the springs, we add elastic roll stiffness with the anti-roll bars to give us total load transfers at each end that come close to the target values we set, and also a roll angle we consider acceptable.

Angular elastic roll stiffness at each end of the car as the angular rate per inch of wheel travel, in pounds inches per inch per wheel or Nmm/mm/wheel, is the sum of the wheel rates at the two wheels in roll from all elastic devices (usually meaning springs and anti-roll bars), times the square of half the track.

The angular rate in lb/in/deg or Nmm/deg is that divided by the number of degrees that an inch per wheel of displacement equates to, which is  $180/\pi$  or 57.3 divided by half the track.

For example, for a 57.3in track, a wheel rate of 500lb/in gives us  $1000 \times 57.3/2$  or 28,650 pounds inches per inch per wheel; and the same for 400lb/in on one side and 600 on the other. An inch per wheel is  $57.3/(57.3/2) =$  two degrees, so the rate in pounds inches per degree is half as much, or 14,325lb/in/deg.

## Weight transfer

Check to see how much of our elastic roll resistance we are getting from the roll bars, compared to the springs. For cars without a lot of downforce, on the road or on road courses, we don't want to get more than about half of our total elastic roll resistance from the bars.

Finally, we need to make sure we aren't predicting 50 per cent load transfer at either end unless we are okay with lifting a wheel. More than 50 per cent is physically impossible. If 50 per cent transfers, that means 100 per cent is on the outside wheel. In some cases, we may have this condition at the light end of the car and still have more lateral acceleration capability at the light end than at the heavy end. That's why we see nose-heavy front-drive cars understeering despite carrying a rear wheel, or old Porsches and Corvairs oversteering despite carrying a front. 

## CONTACT

**Mark Ortiz Automotive** is a chassis consultancy service primarily serving oval track and road racers. Here Mark answers your chassis set-up and handling queries. If you have a question for him, please don't hesitate to get in touch:

**E:** markortizauto@windstream.net

**T:** +1 704-933-8876

**A:** Mark Ortiz

155 Wankel Drive, Kannapolis  
NC 28083-8200, USA

DISCOVER **RACE-**  
**WINNING** COMPONENTS  
AND TECHNOLOGIES

THE **MOTORSPORT SHOW** FOR  
**MOTORSPORT**  
PEOPLE



**TECHNOLOGIES ON SHOW**

- Race Engine and Component Manufacturers
- Performance equipment
- Race car equipment/accessories
- Testing and development
- Safety equipment
- Paddock equipment
- Transportation and logistics
- Race circuit technology

Professional  
**MotorSport**

WORLD EXPO 2018

7, 8, 9 NOVEMBER 2018 COLOGNE, GERMANY

**BOOK  
YOUR  
BOOTH  
NOW!**

PROFESSIONAL MOTORSPORT WORLD EXPO 2018  
Tel: +44 1306 743744 Email: philip.white@ukimediaevents.com

[www.pmw-expo.com](http://www.pmw-expo.com)



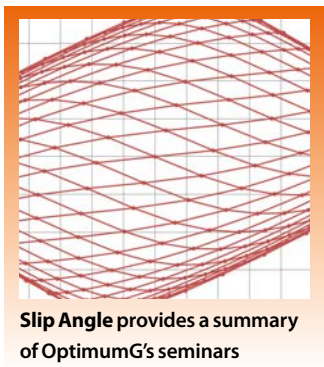

# Lateral thinking on tyre load variations

A seven post rig is all well and good but when it comes to lateral and longitudinal tyre loads OptimumG engineer Claude Rouelle believes there's a need for a fresh approach

**T**yres hate load variations. For a given trajectory you can't change the track bumps, tyre aerodynamic, dynamic loads from lateral and longitudinal, weight transfers or even banking on oval circuits. But with good springs, anti-roll bar and damper settings you can limit the tyre load variation.

Four, seven or even eight post rigs are used to qualify and quantify such tyre vertical load variation. That could be a problem; you look not only for less tyre vertical variation but also for less lateral and longitudinal tyre load variation. But a four or seven post rig won't give the lateral, longitudinal, self-alignment moment value or disturbance.

## A place in the sum

OptimumG performed a test in collaboration with SovaMotion to understand how the variation of the vertical load affects the variation of the lateral force, so we could have a better understanding/correlation of the results from a rig.

When a car is tested on a post rig, the metric used to quantify how much the contact patch load variation and sprung body change is

by calculating the root mean square of the vertical load and dividing it by the average vertical load, as shown in **Equation 1**. Being that the root mean squared (**Equation 2**) is the root sum of the square of all the vertical loads applied divided by the number of vertical loads applied during the test.

We look at this number, from **Equation 1**, as a percentage load variation of the mean load. Most post rig engineers will tell you that 'lower number is less tyre force variation hence better tyre grip'. But is it true?

The question that we need to ask ourselves is: If using this metric is true, by how much should we minimise the load variation? Do we want the same amount of load variation reduction front and rear? Is this relationship linear? By minimising the vertical load variation do we really increase the grip?

Imagine we would have a graph of lateral load variation vs vertical load variation. Let's look at a simplified and exaggerated numerical example (**Figure 1**). If we reduce the vertical load variation from 20 per cent to 10 per cent there won't be a major lateral load

### Equation 1: Transmissibility

$$\frac{RMS(F_z)}{Average(F_z)}$$

### Equation 2: Root mean square

$$RMS = \sqrt{\frac{1}{n} (F_z(t_0))^2 + F_z(t_1)^2 + \dots + F_z(t_n)^2}$$

variation. But a variation that goes from 30 per cent to 20 per cent or 40 per cent to 30 per cent of the vertical load has a larger impact on the lateral force consistency.

Also, what if the front and rear tyre would have a difference  $\Delta F_y$  vs  $\Delta F_z$ ? With a rig we focus on the vertical load variations, but we have little info on lateral load variations. The question we must then answer is: How does the different vertical load variation affect the variation of the lateral force  $F_y$  and longitudinal  $F_x$  and self-alignment  $M_z$  and camber moment  $M_x$  variations?

The questions can also arise if the curve  $\Delta F_y$  vs  $\Delta F_z$  of the front and rear tyre is different, as shown in **Figure 2**. The same decrease of the vertical load variation on the front and rear tyre won't give the same results of the lateral load variation. These could create, for example, for worse or better, a different yaw moment response to a steer input.

We have a good understanding about the non-linearities of suspension springs and dampers but not always so good an understanding about the stiffness and damping of the tyre itself.

## Is it true that a lower number means less tyre force variation?

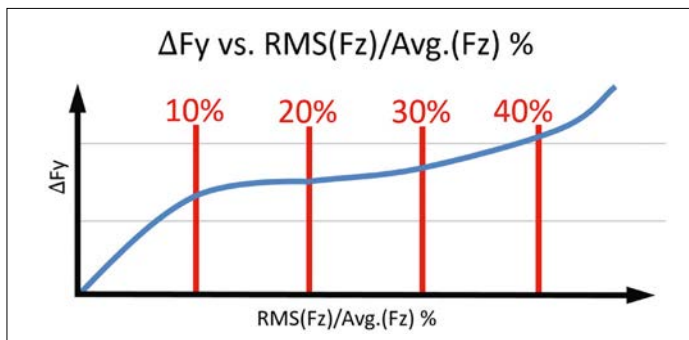

**Figure 1:** This is an example of a hypothesis where decreasing the vertical load variation does not change the lateral force variation in the same way

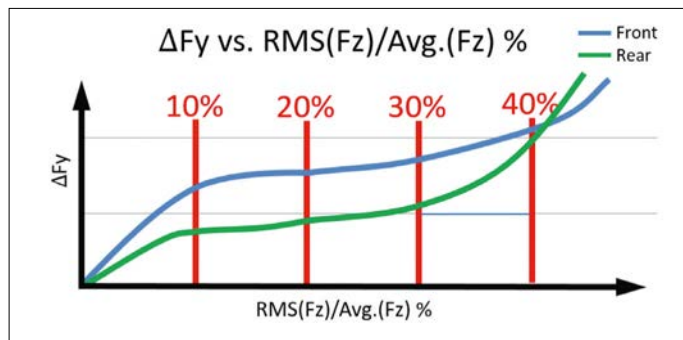

**Figure 2:** This example shows a hypothesis where it's the same as Figure 1, but here it also does not change in the same way at the front and at the rear

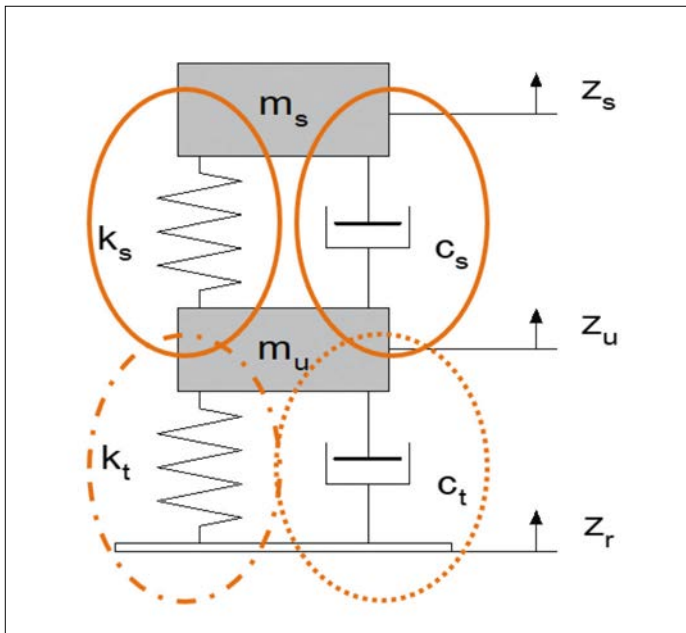

Figure 3: The two stages mass damper quarter car model. But what do we know about a tyre’s vertical stiffness and damping in real track conditions?

Figure 3 shows the two stages mass damper quarter car model that is used to simulate the response of the car to the road input.

How non-linear are the tyre stiffnesses and damping? Are these tyre stiffness and damping speed, camber, vertical load, slip angle, slip ratio, pressure sensitive and even more vertical load amplitude and frequency sensitive?

Table 1 summarises the test conducted by OptimumG. In the test the tyre is steered to a given slip angle and held. We maintained constant static vertical average load (4000N); pressure 1.90bar; speed 40km/h, slip ratio 0 per cent, inclination angle 0deg, slip angle 5deg. During the procedure the frequency of the vertical load is changed according to Table 1. Figure 4 is a picture of this test.

The test was performed at a low speed of 40km/h because at a higher speed the tyre temperature variation would be too big, changing the tyre characteristics. The test was aimed at understanding the coupling between vertical load excitation and the generated lateral

force, as well as to help comprehend how the vertical stiffness/damping of a tyre varies with excitation frequency and amplitude.

### Test limitations

We are aiming to test across the complete matrix in Table 1. The black area was not tested due to the limitations of the machine, at the time, since the maximum speed with which the machine can move vertically is 200mm/s. Five tyres were tested based on this matrix in one day. Serious improvements on both the hardware and software of the tyre testing machine have been made since that test, to reduce the black area of this table.

Figure 5 showcases the vertical force variation (as the input applied by the machine) and the lateral force (as the output measured by the machine). Notice the time delay between the vertical force being applied in the tyre and the tyre generating the lateral force.

Based on the test from Table 1 and Figure 5, Figure 6 is possible. In Figure 6 we are looking at the lateral coefficient of friction (lateral force



Figure 4: The test; the tyre is steered to a given slip angle then held there

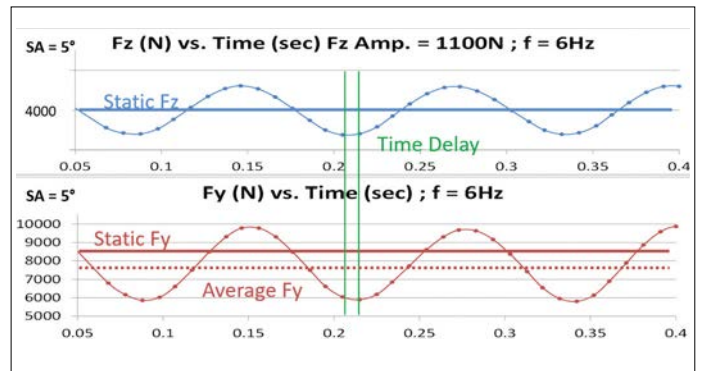

Figure 5: This shows the vertical force excitation versus the lateral force

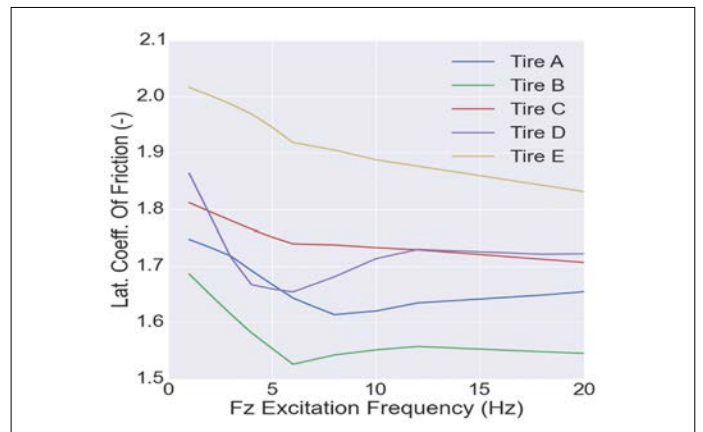

Figure 6: Lateral coefficient of friction versus the different vertical load excitation for the five different tyres. All the tyres lose grip with frequency

divided by the vertical force) of the five different tyres tested at different frequency ranges. As described in Equation 1, the metric used in rig tests is only focused on getting a lower vertical load variation and hence better lateral grip.

The first observation is that all tyres lose grip with frequency. The other observation is that with some of them, like tyres A, B and D, there is a dip representing a frequency where you do not want to go. And that is often the frequency region of a racecar’s suspended mass.

Table 1: The frequencies of the loads that are applied to the tyre

%Stat. Fz Var.	+/- ΔFz (N)	Frequency of Loaded Radius (RL) Vibration (Hz)															
5%	200	0	1	2	3	4	5	6	7	8	9	10	12	18	20		
15%	600	2	4	6	8	10	12	18	20								
25%	1000	2	4	6	8	10											
35%	1400	2	4	6	8												
45%	1800	2	4	6													
55%	2200	2	4														
65%	2600	2	4														
75%	3000	1	3														
85%	3400	1	3														
95%	3800	1	3														

## Intelligent Fully Featured Battery Power Control Systems

# POWERBOX HP 8441 NEW



### Cost Effective Practical Incredibly Versatile

Fully programmable power control in a user friendly package.

Future Upgrade Path to HP8440.

#### Main Features:

- 180 Ampere continuous.
- 34 Output channels controlled as a function of conventional switches, CAN inputs or Virtual channels. With wiper Park on dedicated channels.
- Weight 496 gr.

## MEMBRANE PANEL



CAN Controlled Membrane Switch Panel. Tactile Operator Feedback. Multi Tap Capability. Warning LED's. Available With Your Custom Design.

## POWERBOX HP 8440



#### Main Features:

- 200 Ampere continuous.
- Programmable Inrush Currents
- 34 Individually Programmable Output Channels
- 11 Conventional Switched Inputs
- 32 CAN Input Channels
- 20 Virtual Logic Channels
- CAN Export Facility
- Weight 680 gr.

*Future Proof With  
Firmware upgrades*

**OVER 1000 UNITS SOLD WITH PROVEN RELIABILITY  
ENGINEERED & PRODUCED WITH OUR EXPERTISE IN HOUSE. LEARN MORE AT [HPELEC.DK](http://HPELEC.DK)**



**HP ELECTRONIK**

Lundvej 17-19, Lund  
7400 Herning · Denmark

Tel. + 45 9626 4333  
Fax + 45 9626 4233

info@hpelec.dk  
www.hpelec.dk

**Spot the winner**



Maximum precision and uncompromisingly rugged design: these are the hallmarks of our motor racing sensors. They can withstand harsh conditions on racing circuits with supreme ease, steering your vehicle to success – lap after lap. Wherever and whenever you need technical support, we are ready to assist with our complete, customized solutions and full-scale professional service across the globe.

[www.kistler.com](http://www.kistler.com)

**KISTLER**  
measure. analyze. innovate.

# It's important to consider tyre stiffness when calculating your dynamic ride height

In **Figure 7** and **Figure 8** for the same conditions applied (average vertical load of 4000N; slip angle of 5deg; inclination angle of 0deg; velocity of 40km/h and a slip ratio of zero per cent) we plotted the tyre vertical stiffness for the range of different vertical load excitation, also coloured with the rolling radius for tyres A and D. Tyres A and D have a similar vertical stiffness but as the frequency increases you can see that the vertical stiffness for tyre A increases while tyre D decreases. The tyre stiffness is an important parameter to consider for the calculation of your dynamic ride height, and as the frequency changes the tyre stiffness is varying, with this in mind a correction of the static ride height and/or the suspension spring stiffness would be needed. We can also see that at 0Hz (the tyre is not moving) for different pressures the tyre stiffness changes and the higher the pressure the stiffer it is, but as you start exciting the tyre the vertical stiffness is changing, in the case of tyre D at 20Hz (a bumpy track) the tyre stiffness decreases to half.

**Figure 9** shows the vertical load versus displacement for one of the tyres for two different frequencies but the same amplitude. In blue is a frequency of 2Hz and in red of 6Hz. We can clearly see that as the frequency changes the damping of the tyre changes a lot, and at higher frequency its hysteresis is bigger, when compared with low frequency.

## New models

We are pioneering an approach to useful transient tyre testing and applying new models in vehicle dynamic studies. This test paves a way to new tyre frequency response analysis and is a possible application to four and seven post rig testing.

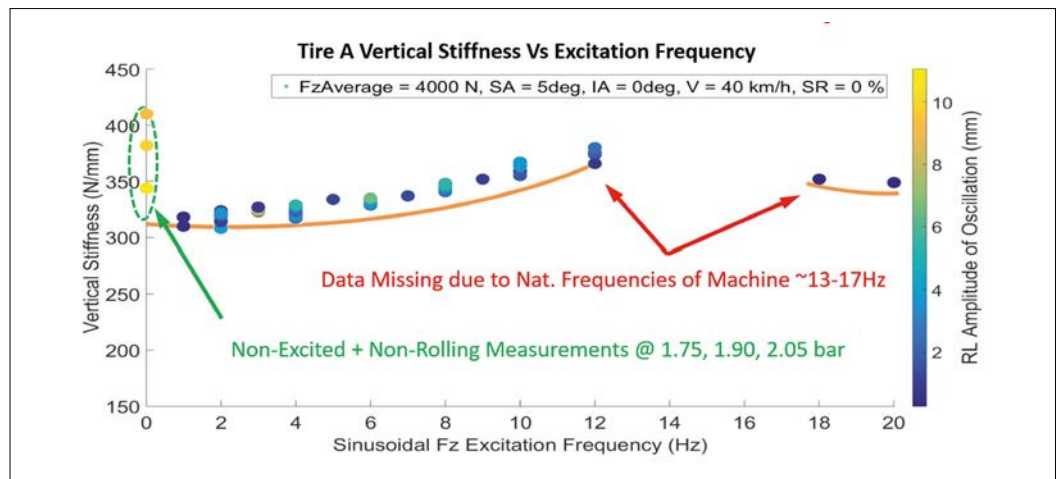

**Figure 7: Vertical tyre stiffness vs excitation frequency for tyre A. This has a similar vertical stiffness to D, below**

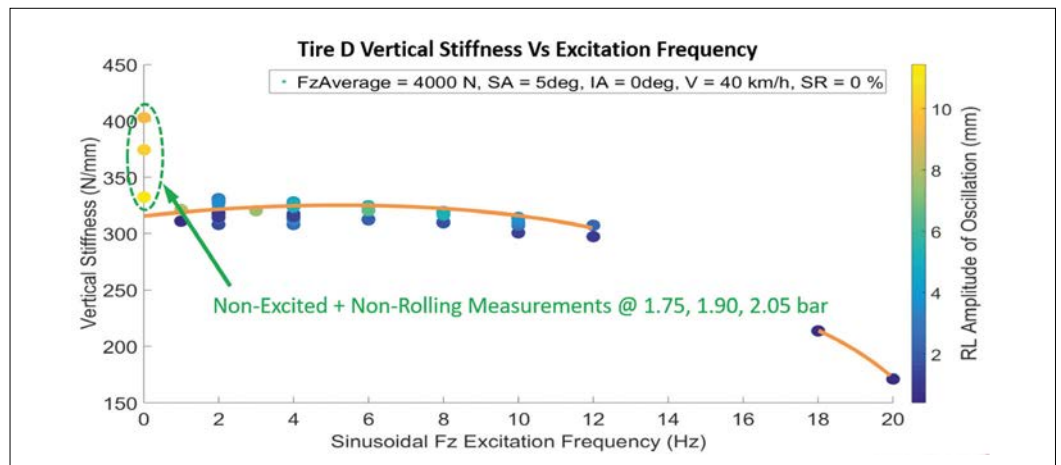

**Figure 8: Vertical stiffness vs excitation frequency for tyre D. The stiffness decreases as the frequency increases**

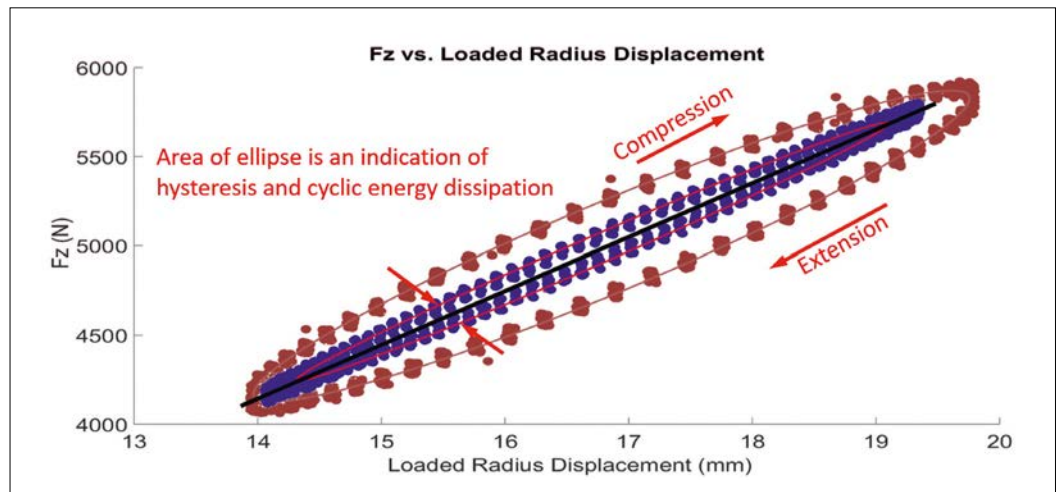

**Figure 9: Frequency of 2Hz is shown in blue and 6Hz is shown in red. Note the changes in the damping of the tyre**

From this test it has been observed that there is a frequency range in which some tyres lose grip quicker than in other parts of the excitation spectrum shown in **Figure 6**. From the tyre vertical excitation test we can conclude that the metric used to quantify the contact patch load variation and sprung body change doesn't necessarily translate to a better performance of the racecar on the

track. It can be seen that there is a frequency range in which the tyre loses grip quicker than in the other parts of the excitation spectrum.

The tyre vertical stiffness changes with vertical load variation and depending on the tyre it can either increase or decrease. This is actually an important value to consider for any racecars running with aerodynamics, because it will affect the dynamic ride height.

**CONTACT**  
 Claude Rouelle  
 Phone: + 1 303 752 1562  
 Enquiries: engineering@optimumg.com  
 Website: www.optimumg.com

# QUALITY PERFORMANCE RELIABILITY



WWW.SUPERTECHPERFORMANCE.COM

- ✓ VALVES
- ✓ PISTONS
- ✓ RODS
- ✓ HEAD GASKETS
- ✓ COMPONENTS

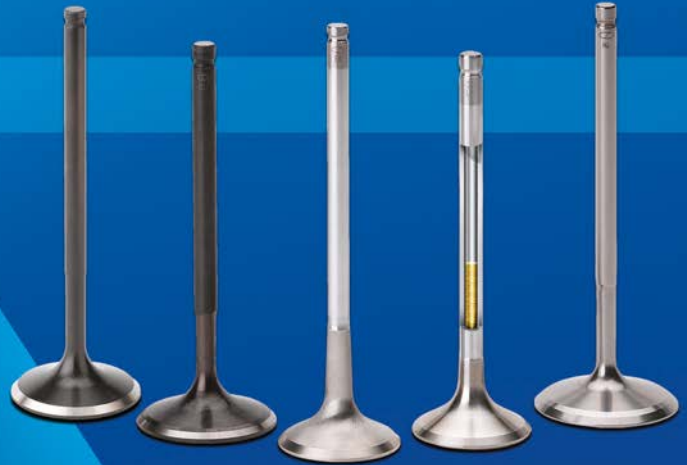

## RFC-89



**NEW**  
**2ND GENERATION**  
**FIA & ACO APPROVED**  
**RACE CAR REFUELLING SYSTEM**

## KRONTEC

HIGH PERFORMANCE COMPONENTS

- RE-ENGINEERED COMPACT DESIGN ONLY 1038 GRAMM
- ADVANCED SURFACE COATING OF SAFETY CRITICAL COMPONENTS
- FULLY GUIDED NIPPLE TO REDUCE SPILLAGE AND IMPROVE SAFETY
- TOTALLY INTERCHANGEABLE WITH CURRENT RFC-88-SYSTEM
- OPTIMIZED FUEL FLOW WITH CFD TECHNOLOGY



Abbildung: Strömungsgeschwindigkeit Detailansicht

# -35mm Worlds apart

Our technology centre is the most advanced in Europe.

That is how we can achieve a negative radius of up to -35mm. Extreme engineering and precision that other performance cam manufacturers in Europe cannot match. All our camshafts and ancillaries have been developed by the best to be the best.

**Nº1**

**Kent Cams – the best in Europe:**

- No.1 for product development expertise
- The greatest performance increase of any single modification
- The widest range of camshaft ancillaries produced on site

- **The most advanced technology:**  
Negative radius to -35mm  
CBN wheels with constant surface speed  
Multi-angle lobes with CNC dressing  
Marposs 3D C and Z axis position probe  
Microphonic wheel dressing  
Lotus Concept Valve Train software



**HIGH PERFORMANCE  
ENGINEERING**

[www.kentcams.com](http://www.kentcams.com)

Cams + Pulleys, Belts & Chains :: Valves & Valve Springs :: Performance Cam Kits & Valve Spring Kits :: Followers & Tappets

**VAC**  
MOTORSPORTS

World Leading Performance



**SAMSONAS**  
MOTORSPORT TRANSMISSION

### Gearboxes and Gear Sets

- » Rally, Drag, Hill Climb, or Road Racing
- » For BMW, Mitsubishi, Subaru and More
- » Dog Gearboxes Available for 4, 5 and 6 Speed Units



**CARRILLO**

### Forged Pistons

- » Pistons Available From CP and JE
- » Part of VAC Stroker and Turbo Kits
- » Perfect For High Performance Applications

*Duiley  
Engineering*

### Billet Dry Sump Kits

- » Increases HP and Reliability
- » 4-cyl, 6 cyl, V8 & V10 applications
- » Full Kits with Pumps also available



### **tilton** VAC Clutch & Flywheel Kits

- » Rally, Race, & Carbon Clutches
- » Lightweight Flywheel included!
- » Twin & Triple Disc Clutches in 5.5" & 7.25"



**SCHRICK**

**ARP**  
automotive racing products

**ARROW**  
RACING

**SAMSONAS**  
MOTORSPORT TRANSMISSION

**COMETIC**

**CARRILLO**

+1.215.462.4666

[www.vacmotorsports.com](http://www.vacmotorsports.com)

2501 Snyder Ave, Philadelphia, PA 19145, USA

[sales@vacmotorsports.com](mailto:sales@vacmotorsports.com)





# Front aero tweaks on a Tyrrell 012

Our post ground effect F1 study continues with wing adjustments

The 1983 season saw one of the FIA's most drastic bodywork rule changes in Formula 1 history, when the 1977-1982 generation of cars featuring ground effect sidepods with profiled undersides was completely banned while flat bottoms between the axle lines became mandatory.

Some of the teams, including Tyrrell and Brabham, designed cars to the new rules that almost totally abandoned sidepods altogether, while others, including Ferrari and Renault, which perhaps coincidentally finished first and second in the 1983 constructors' championship, retained long sidepods (although one of the Brabhams won the drivers' championship).

At these early stages of flat bottom rules clearly there was no particular favoured concept, although that was set to change in subsequent years. In the meantime the Tyrrell 012, which we are privileged to have as our wind tunnel test subject again this month, occasionally ran in the upper midfield in what was a fairly patchy season for the team.

Following the loss of the ground effect sidepods, the 1983 Tyrrell 012 relied almost totally on its wings to generate downforce, with a single element, large chord front wing fitted with a Gurney, complemented by the low aspect ratio deeply cambered three-element rear wing with Gurney. As a brief refresher, or in case you don't (yet) have a subscription and



Here the front wing is at the maximum angle tested and the smoke plume shows the upwash at the trailing edge

Table 1: Front wing angles

F/wing angle	CD	-CL	-CLfront	-CLrear	%front	-L/D
7.4deg	0.835	0.685	0.147	0.538	21.5%	0.820
8.9deg	0.837	0.718	0.193	0.524	26.9%	0.858
10.0deg	0.835	0.734	0.229	0.505	31.2%	0.879
11.1deg	0.834	0.741	0.249	0.492	33.6%	0.888
12.5deg	0.836	0.736	0.253	0.484	34.4%	0.880

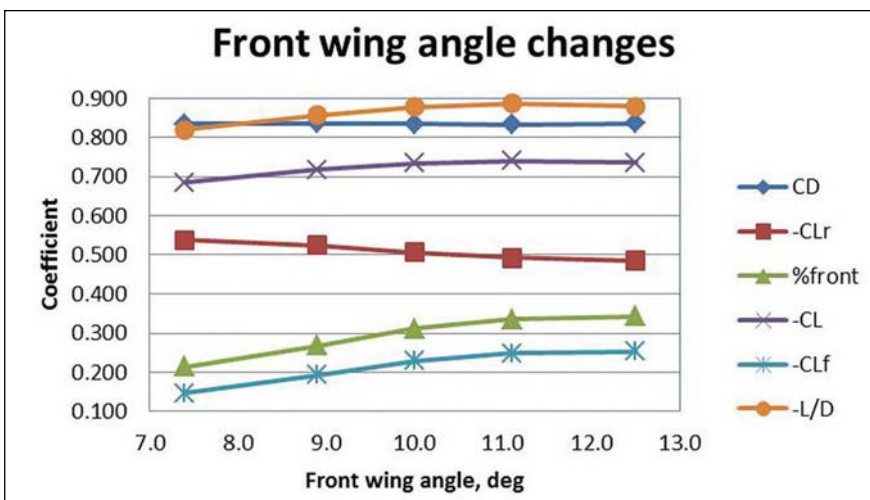

This chart shows the effects of our front wing angle tweaks on all of the Tyrrell 012's aerodynamic parameters

so you missed last month's issue, the baseline coefficients recorded on the Tyrrell showed the usual high drag levels, very close to other non-current Formula 1 cars we have tested in the MIRA tunnel, and pretty modest downforce with quite a rearward bias.

Total downforce was almost exactly the same as a 1983 Arrows A6 that we tested in 2007, but the Arrows had a downforce balance of almost 41 per cent front, compared to roughly 20 per cent front on the Tyrrell at the start of our session. So, following some trials to reduce the Tyrrell's drag with rear wing flap angle, slot gap and Gurney changes, the rear wing was reset to approximately where we started the session and some front wing angle increases were made to investigate the range

**The Tyrrell relied almost totally on its wings to generate downforce**

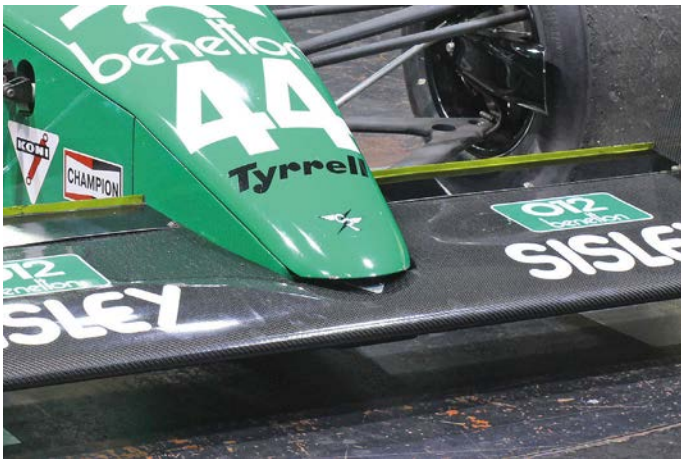

Nature abhors a vacuum, and aerodynamicists distrust a gap. But would this small space between the nose and the front wing's upper surface really make a difference?

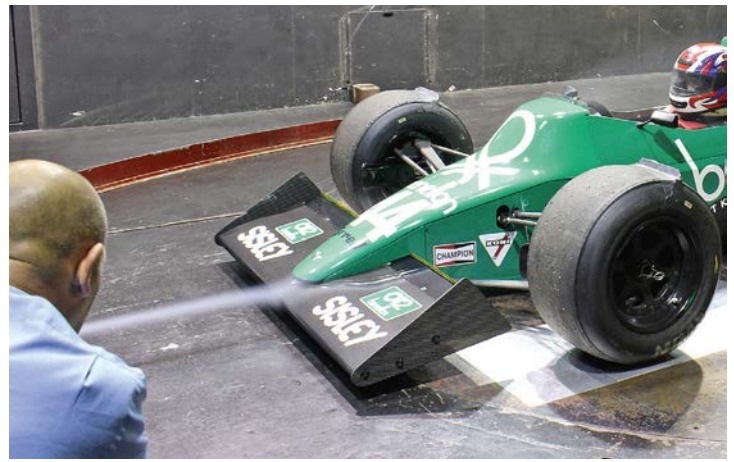

The smoke was played over the gap (pictured) and then the race tape was put to work to smooth it over. Without the tape there was a tiny drag penalty and a small downforce gain

**Table 2: The effects of smoothing over the gap between the nose and the front wing**

	$\Delta CD$	$\Delta CL$	$\Delta CL_{front}$	$\Delta CL_{rear}$	$\Delta\%front^*$	$\Delta-L/D$
Taped gap	-5	-5	-5	-	-0.4%*	

\*Changes in %front are absolute, not relative

## Both the total downforce and the efficiency curves peaked at a front wing angle of 11 degrees

of balance adjustment. **Table 1** tabulates the results and **Figure 1** shows them graphically.

A number of interesting trends become apparent in this set of data. First, drag basically didn't change at all with increasing front wing angle, as we have seen previously and now come to expect on single seaters. Second, front downforce increased linearly across the first three angles measured, and then the gains started to tail off in a way that suggested 12.5deg was at or at least very close to the peak front wing angle. The downforce balance (%front) curve ran essentially parallel to the path of the front downforce curve.

Interestingly both the total downforce and the efficiency (-L/D) curves peaked at a front wing angle of 11deg, because while the gains in front downforce levelled off at 12.5deg, the losses in rear downforce continued. This implies that those rear downforce losses were not purely down to the increased mechanical leverage of the front wing, but that there was also a small adverse downstream aerodynamic effect from the front wing, as its angle was increased, on the rear wing.

In the image on the previous page the front wing was at the maximum angle tested, and the smoke plume shows the upwash at the trailing edge. The smoke becomes more diffuse downstream but it is just possible to see that this diffuse flow field is at a height that would interact with the rear wing's flow field.

The change in balance from the starting angle (as had been run at the previous weekend's Silverstone Classic) to the upper

angles was quite marked, and at around 34 per cent front it appeared to be at a level more likely to be balanced on track.

However, as noted in last month's instalment, the MIRA wind tunnel's fixed floor will tend to underestimate the downforce of a ground proximity device such as a front wing, whereas the rear wing's downforce contribution would be essentially unaffected, so this would exaggerate the reward bias compared to that found on track. Indeed, assuming the car was balanced on track with the starting front wing angle, then this implied that the front wing's downforce may have been underestimated in the wind tunnel by as much as 40 per cent. This is likely to be especially pertinent to a car with no downforce-inducing underbody and which has a centre of pressure between the front and rear wheels, which would mitigate the difference in measured balance.

### Mind the gap

Sometimes details that look as though they may potentially cause aerodynamic deficiencies catch the eye. And sometimes this actually proves to be the case, although as often as not they can be of little significance too.

One such detail was the gap between the nose cover and the top surface of the front wing. There was no possibility for air to be able to get under the nose cover, but nevertheless it just looked wrong. So some strips of the ever-handy remedial race tape were applied to smooth over the gap, and the results from the taping session are shown in **Table 2** as delta ( $\Delta$ )

values expressed in counts, where one count is a coefficient change of 0.001.

Looking at **Table 2**, then, there was a small measurable effect, with drag reducing by five counts (or 0.6 per cent) when the gap was taped over, but front downforce also reduced by five counts (or 2.0 per cent).

Viewing the image at the top right of this page it's easy to envisage that the gap under the nose cover would tend to slow the airflow down more than when it was smoothed over with tape, which would increase the local static pressure here, leading to the increased drag and also the increase in downforce which was measured at the front wheels. In this instance then it was probably worth taking the small hit on drag in exchange for the extra two per cent of front downforce, reduced consumption of tape and one less job on the preparation list.

Next month we will be looking at ride heights and ground clearance. Thanks to Martin Adams (owner), Nigel Rees at GSD Racedyn and Martin Stretton and Russell Sheppard at Martin Stretton Racing. 

### CONTACT

**Simon McBeath** offers aerodynamic advisory services under his own brand of SM Aerotechniques – [www.sm-aerotechniques.co.uk](http://www.sm-aerotechniques.co.uk). In these pages he uses data from MIRA to discuss common aerodynamic issues faced by racecar engineers

Produced in association with MIRA Ltd



Tel: +44 (0) 24-7635 5000

Email: [enquiries@horiba-mira.com](mailto:enquiries@horiba-mira.com)

Website: [www.horiba-mira.com](http://www.horiba-mira.com)

## There was a marked change in balance from the starting angle to the upper angles

# Configure Your Chell Scanner

High accuracy to 0.04%FS absolute

Configurable Absolute or Differential

Versatile core - bespoke configurations

CAN & Ethernet Outputs

Embedded web server setup

Rugged IP67 construction

...plus O-ring seal QD plate option

**Chell**  
Instruments

www.chell.co.uk | +44 (0) 1692 500555

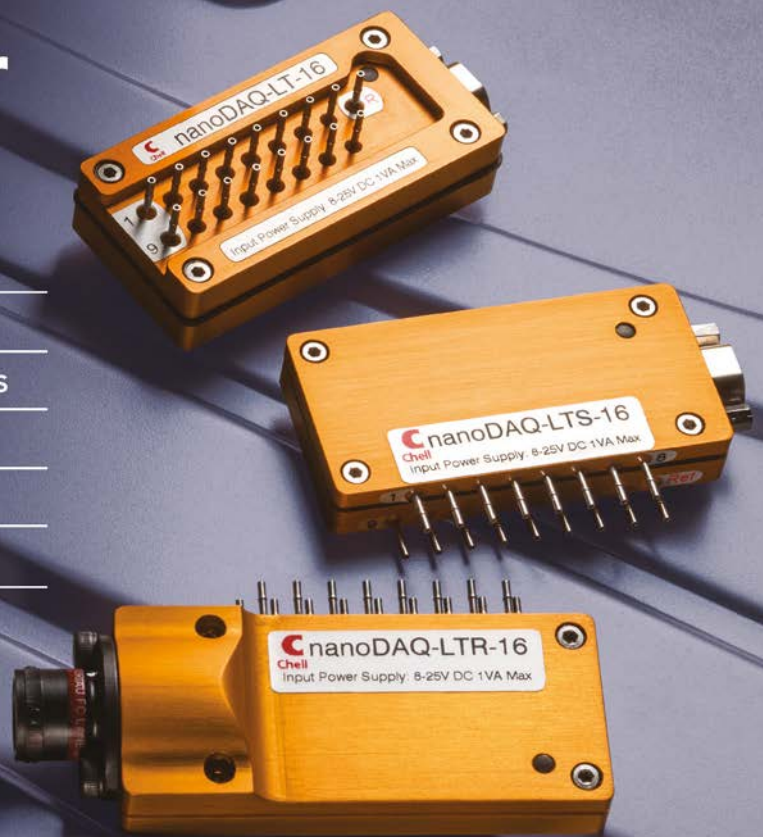

## CARTEK MOTORSPORT ELECTRONICS



### NEW! POWER DISTRIBUTION PANEL

CARTEK are pleased to announce the new Power Distribution Panel is now available. This product is a full redesign of their successful but bespoke, Power Control Panels, with the main aim of allowing the user to customise and configure it themselves

The CARTEK Power Distribution Panel is a fully integrated, fully electronic solution to power distribution in race and rally cars. Designed to replace 16 Fuses, Relays and Switches as well as a variety of control systems, these units therefore greatly simplify the wiring, reducing build time, saving weight and maximising reliability.

The 140x195mm panel only weighs 625g and is enabled with short circuit and over-current protection.



2 x Multicoloured Sticker Packs included

#### Key features:

- 16 User Configurable Channels (no Laptop required)
- 7 Selectable Amperage Settings: (0A, 5A, 10A, 15A, 20A, 25A, 30A)
- Choice of Functions such as: Momentary, Latching, Flashing etc
- 2 Backlight Settings
- Status LED for each Channel
- ECU and Switch Inputs available
- Dedicated Wiper Control Module

### BATTERY ISOLATOR XR



The new Battery Isolator XR can output a signal to shut down the CARTEK Power Distribution Panel as well as Isolate the Battery.

### WIRELESS CONTROL SYSTEM



Use the Wireless Control System to communicate with the CARTEK Power Distribution Panel or ECU/Dashboard

For more information go to [www.CARTEKMOTORSPORT.com](http://www.CARTEKMOTORSPORT.com)

# Know your limits

**This year Formula 1's CFD restriction regime has been shaken up big time as the FIA looks to cut the costs of aerodynamic development. But has it worked, and how has it changed both the tools and the process? *Racecar* investigates**

By **GEMMA HATTON**

In January 2018, the FIA introduced the latest evolution of aerodynamic testing restrictions for Formula 1, and with them came the biggest change in CFD restrictions since they were first introduced back in 2009. *Racecar* went behind the scenes with HPC specialist, Boston Ltd, to discover the impact of these changes and how Formula 1 teams have not only benchmarked new solutions, but also upgraded their CFD supercomputers.

But to put these latest changes into context we need to understand the history of the restrictions, both for CFD and the wind tunnel. In 2008, aerodynamic testing was at its peak. BMW Sauber, Honda, Williams and Toyota had all invested huge sums of money in new state of the art full size wind tunnels, each costing tens of millions of pounds. All the top teams were operating in two wind tunnels simultaneously, while Toyota was not only using two wind tunnels 24/7, but each of these was full size.

However, the vast majority of this wind tunnel testing utilised scale models, and over the years the scale of these models increased from 40 per cent to 50 per cent and then 60 per cent. Operating two wind tunnels full time allowed these teams to complete around 500 wind tunnel simulations per week, with each simulation incorporating approximately 20 different car attitudes. Full size wind tunnel testing was commonplace, with teams either using their own facility or a customer facility such as Windshear in the USA.

UNIFI LTD

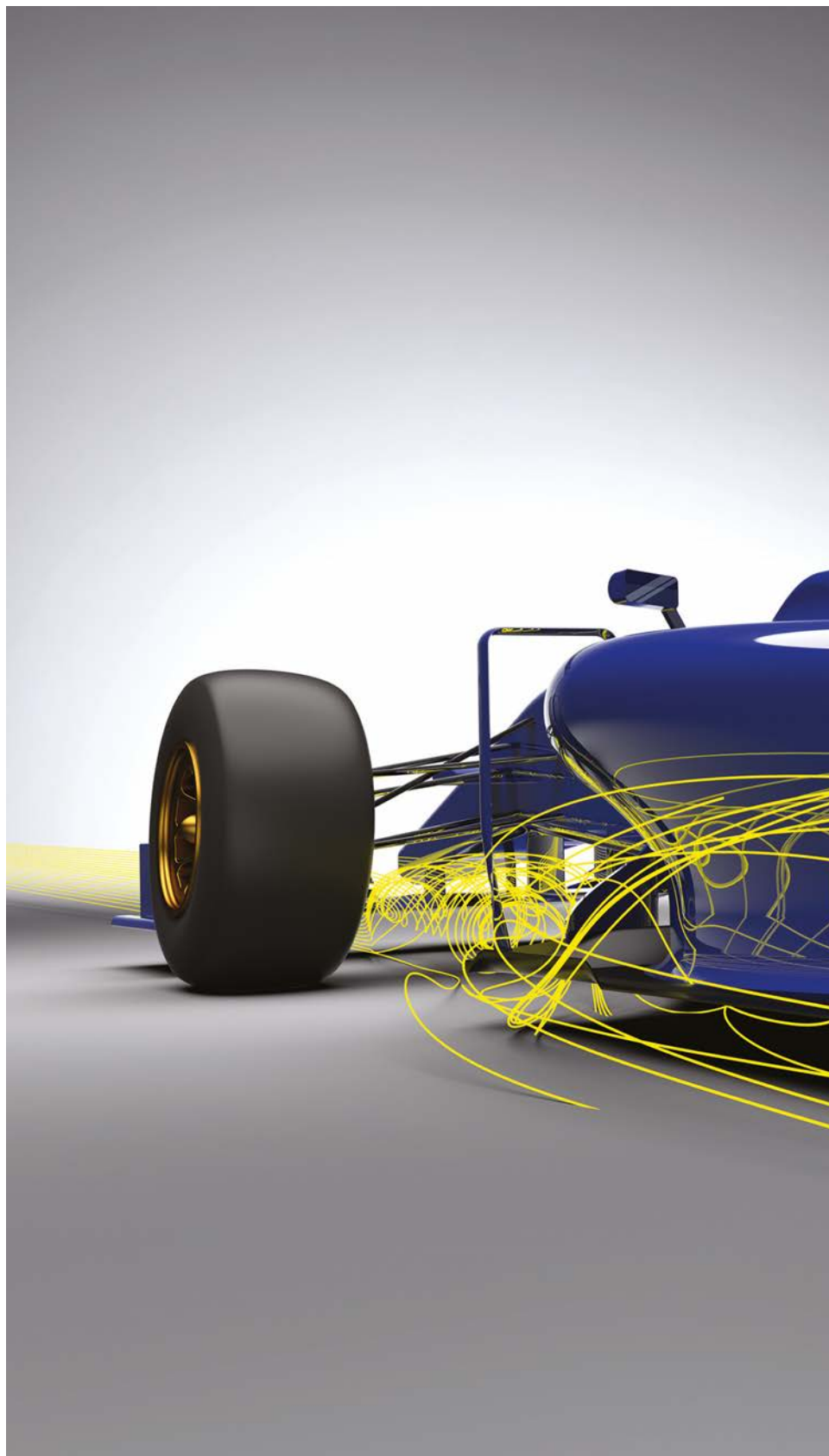

Boston worked together with UniFi and CE to benchmark the performance of new CFD technologies in accordance with the 2018 regulations to see if F1 teams would be forced to upgrade their CFD capability

**It quickly became clear that something had to be done to curb the growth of aerodynamic testing in F1, and its associated costs**

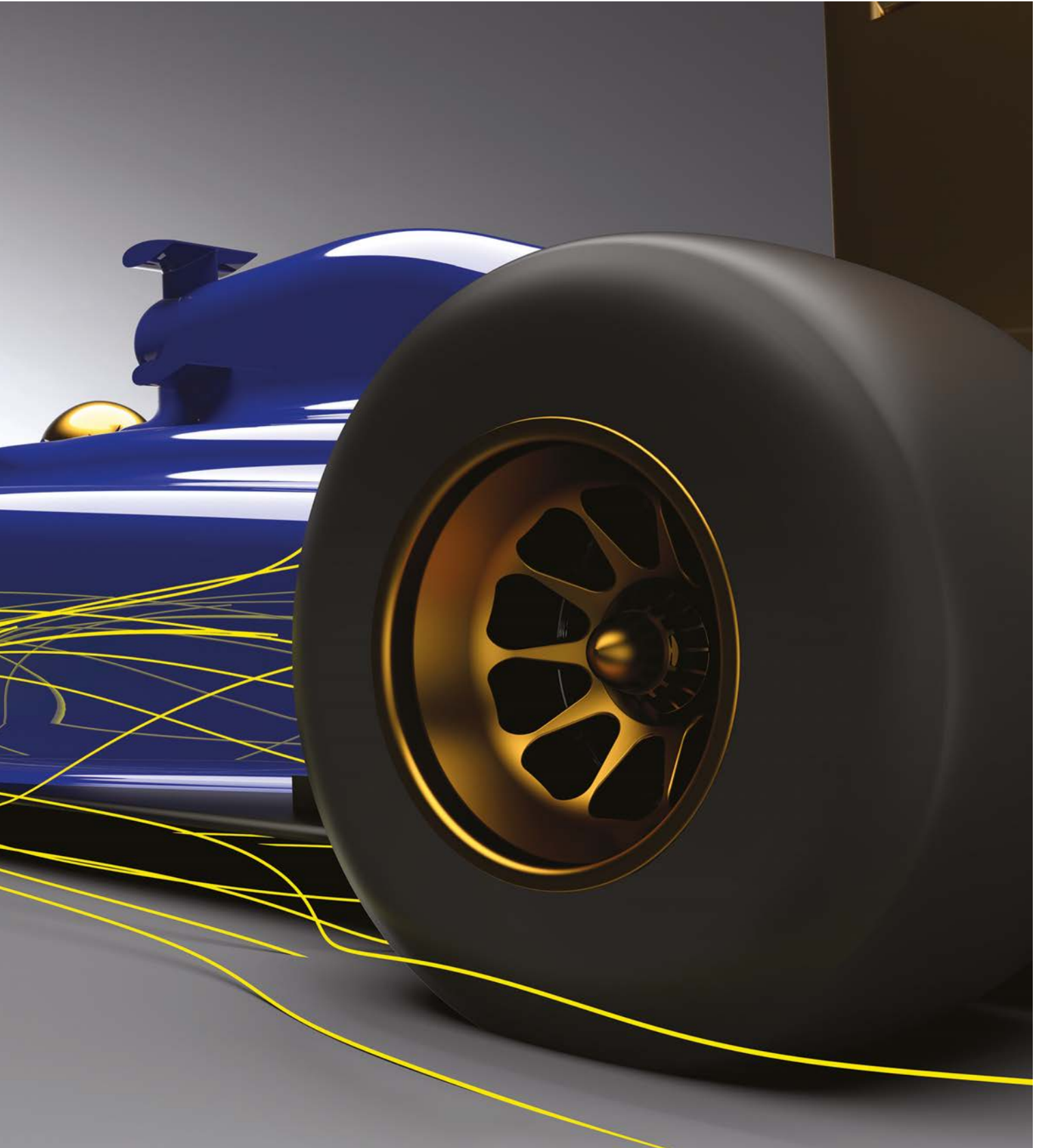

In 2008 teams were already using CFD routinely as part of the aerodynamic development process, and as the software and correlation improved while hardware costs reduced, teams began to use it more, integrating it further into the design cycle.

At that time, BMW Sauber was leading the way in CFD hardware with the Albert 3 supercomputer and over 4000 Intel cores, but other leading teams were not far behind. It quickly became clear that something had to be done to curb the growth of aerodynamic testing in Formula 1, and its associated costs.

The first step came into force in January 2009 as part of the FOTA Resource Restriction Agreement (RRA). This controlled the aerodynamic resources the Formula 1 teams could deploy via restrictions on the wind tunnel 'wind on time' (WON) and the CFD compute capacity, measured in TeraFLOPs (TFLOPs).

Wind on time was simply a measure of the amount of time the fan was turned on in the wind tunnel with the wind speed in the test section above 15m/s. For CFD, TFLOPs was effectively the number of floating point operations completed within the designated eight week Aerodynamic Testing Period (ATP) and was defined by the following equation:

$$TotFLOPs = \frac{MFPPC \times CCF \times NCU \times NSS}{604,800 \times 8 \times 1,000}$$

**Where:**

- TotFLOPs = Total number of TeraFLOPs used per second
- MFPPC = Peak double precision floating point operations per cycle per core of the processing unit
- CCF = Peak processing unit clock frequency in GigaHertz
- NCU = Number of processing unit cores used for the run
- NSS = Number of solver wall clock seconds elapsed during the run

Between 2009 and 2017 the regulations evolved and generally served to reduce the aerodynamic resources available to the Formula 1 teams, particularly in the wind tunnel. This was done through introducing a 'limit line' which is defined by the following equation.

$$WT \leq WT\_limit \left(1 - \frac{CFD}{CFD\_limit}\right)$$

**Where:**

- WT = Wind on time
- WT\_limit = 25 hours
- CFD = TeraFLOPs usage
- CFD\_limit = 25 TeraFLOPs

Therefore, the amount of time a team chose to run its CFD directly dictated how much time it could utilise the wind tunnel. Equally, if a team could complete its maximum allocation of wind tunnel runs using less wind on time then it would have more capacity for CFD simulations.

## Working area

Looking at the WT\_limit and CFD\_limit data from the last few years, **Figure 1** can be created. Essentially, by plotting the maximum of each of these limits, you can establish the 'working area' that the teams could operate in. For example, in 2013, when the maximum WT\_limit was 60 hours and the maximum CFD\_limit was 40 TeraFLOPs, the team could operate anywhere within the green shaded area. In 2014, the limits were 30 hours WT and 30 CFD TeraFLOPs, illustrated by the red shaded area, whilst 2015 was limited to 25 hours WT and 25 CFD TeraFLOPs, represented by the blue shaded area, which remained the same until 2018.

Since 2013, you can see that overall testing has dramatically reduced, but particularly for the

wind tunnel. For example, let's assume that CFD capacity allows a maximum of 12.5 TeraFLOPs. Using the equation with the 2013 limits results in 41.3 hours of wind on time, as shown by the green square. In 2015, however, 12.5 TeraFLOPs would only give you 12.5 hours in the wind tunnel (blue square) – that's 70 per cent less than 2013. The exact balance between CFD and wind tunnel resources varies from team to team, and sometimes from year to year, depending on the strategic approach and technology advances adopted by each team.

Of course, every restriction that is introduced simply triggers the teams to exploit the loopholes and optimise their designs and working practices to maximise their performance from the regulations. For the TFLOPs CFD restrictions, this became an arms race as teams pushed to develop their supercomputers to run the most CFD simulations per given TFLOP allowance. This led teams to operate CFD hardware in ways which were quite different from the wider industry, with a clear focus on regulatory efficiency rather than financial efficiency. For example, the TFLOPs calculation naturally includes a chip clock speed term which is reported either as the maximum turbo clock frequency stated on the CPU specification (if the turbo mode is used), or the base clock frequency if the turbo mode is not used. Teams quickly established that the turbo mode was not an efficient way to run CFD simulations, in terms of the number of CFD simulations completed per TFLOP. This was also true for many higher clock speed chips.

Effectively, running supercomputers with slow clock speed was giving teams more efficiency under the regulations but with the obvious penalty in terms of CFD simulation

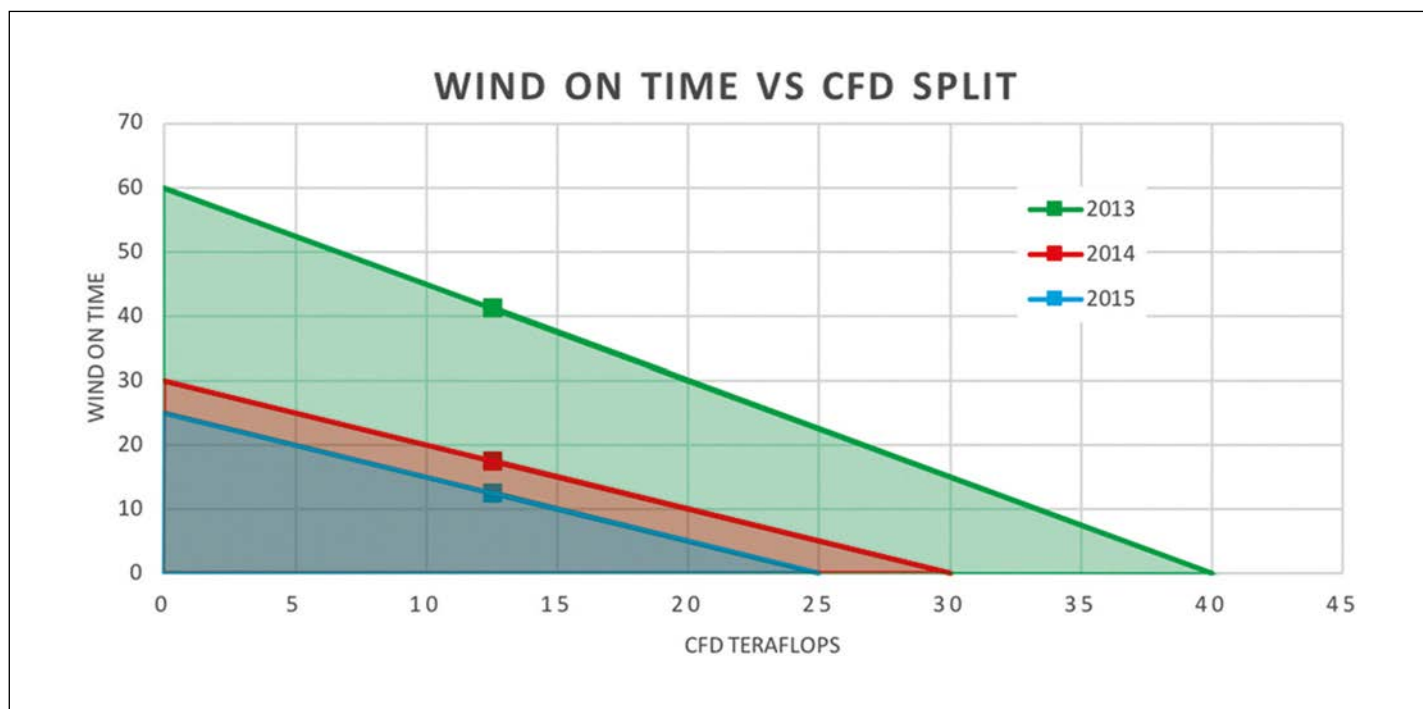

Figure 1: The FIA has restricted aerodynamic testing over recent years for both CFD and the wind tunnel, but particularly the latter. This graph shows the 'working area' that the teams have been able to operate in. Assuming a maximum CFD capacity of 12.5 TeraFLOPs you can see that wind on time has dropped by 70 per cent between 2013 and 2015



WE CONNECT TECHNOLOGY



- ✓ VAD FOR SOURIAU BSTA CONNECTORS
- ✓ ULTRA MINIATURE HARSH ENVIRONMENT CONNECTORS
- ✓ MIXED POWER AND SIGNAL CONNECTORS
- ✓ HERMETIC CONNECTORS
- ✓ DEDICATED ASSEMBLY TOOLING
- ✓ FUEL PROOF HEAT SHRINK BOOTS
- ✓ ULTRA LIGHTWEIGHT ACCESSORIES

+44 (0) 1403 790 661

LANEMOTORSPORT.COM

MOTORSPORT@FCLANE.COM

**SOURIAU**  
CONNECTORS

**Weald**  
ELECTRONICS  
ACCESSORIES

**HellermannTyton**  
HEAT SHRINK BOOTS



**ONLINE SHOP**  
FOR AFTER HOURS ORDERING



# HIGH PERFORMANCE SAFETY FUEL CELLS



STANDARD OR CUSTOM **SAVER CELLS**  
RANGING FROM 10 - 170L



**NEW!**

**60 LITRE D-CELL**

DESIGNED TO FIT EASILY INTO THE WHEEL WELL OF MOST CARS! OPTIONS & ACCESSORIES AVAILABLE



MANUFACTURER: ATL LTD  
HOM. NO: ATL 565  
FIA STANDARD: FT3-1999

## CHECK YOUR REGULATIONS

VEHICLES IN GROUPS N, A, R1, R2, R3 AND E-1 RUNNING TO APPENDIX J OF THE FIA SPORTING CODE NOW REQUIRE AN FIA CERTIFIED FUEL CELL



### CUSTOM FUEL SYSTEMS

INTERNAL COLLECTORS & SURGE TANKS, FUEL PUMPS, FILTERS, FOAM BAFFLING & MUCH MORE!

### HISTORIC REMAKES

RETAIN ORIGINAL LOOK BY USING EXISTING OR RE-MADE CONTAINER



**ATLLTD.COM**

+44 (0)1908 351700 sales@atlltd.com

turnaround time. Therefore, teams then had to balance the speed with which they receive their CFD results against the total number of CFD simulations they were able to complete within the regulatory framework. This is quite different to the wider CFD industry, where the turbo mode was 'free' performance and quicker clock speeds were performance gains if your main criteria was financial efficiency, and so the divide between the two environments was underway from 2009 onwards.

### Cores and effect

Core under-population also became commonplace in Formula 1 as it delivered further regulatory efficiency gains for the teams. It was efficient for the FIA TFLOPS

regulation, but it was very inefficient financially, with as much as half of the purchased HPC compute cores being left idle.

The biggest issue came when one of the teams developed the Fangio chip in collaboration with AMD, a chip specifically designed to optimise the balance between CFD case turnaround time and throughput which gave that team a huge initial advantage.

This exploited the fact that the modern HPC chips were then rated at eight double precision flops/cycle but commercial CFD codes were only capable of delivering approximately one dp flop/cycle. The Fangio chip was designed to operate at two dp flops/cycle giving a big efficiency improvement in MFPPC. Following lobbying from various teams,

the FIA agreed to consider the rival Intel chips (Sandybridge and Ivybridge) as four dp flops/cycle for the purposes of the regulations rather than their rated eight dp flops/cycle.

By 2012 AMD had been persuaded by many teams to produce a second limited run of Fangio chips, allowing more of the grid to upgrade their supercomputers to this specification, with most of the remaining teams running an Intel Ivybridge system. With the FIA unwilling to extend the flops/cycle exemption to more modern Intel chips, such as the V3 Haswell CPUs which were rated at 16 dp flops/cycle, and AMD not producing any more Fangio chips, the teams were now locked into these older systems purely by virtue of the regulations. Newer chips were simply not viable because of their high

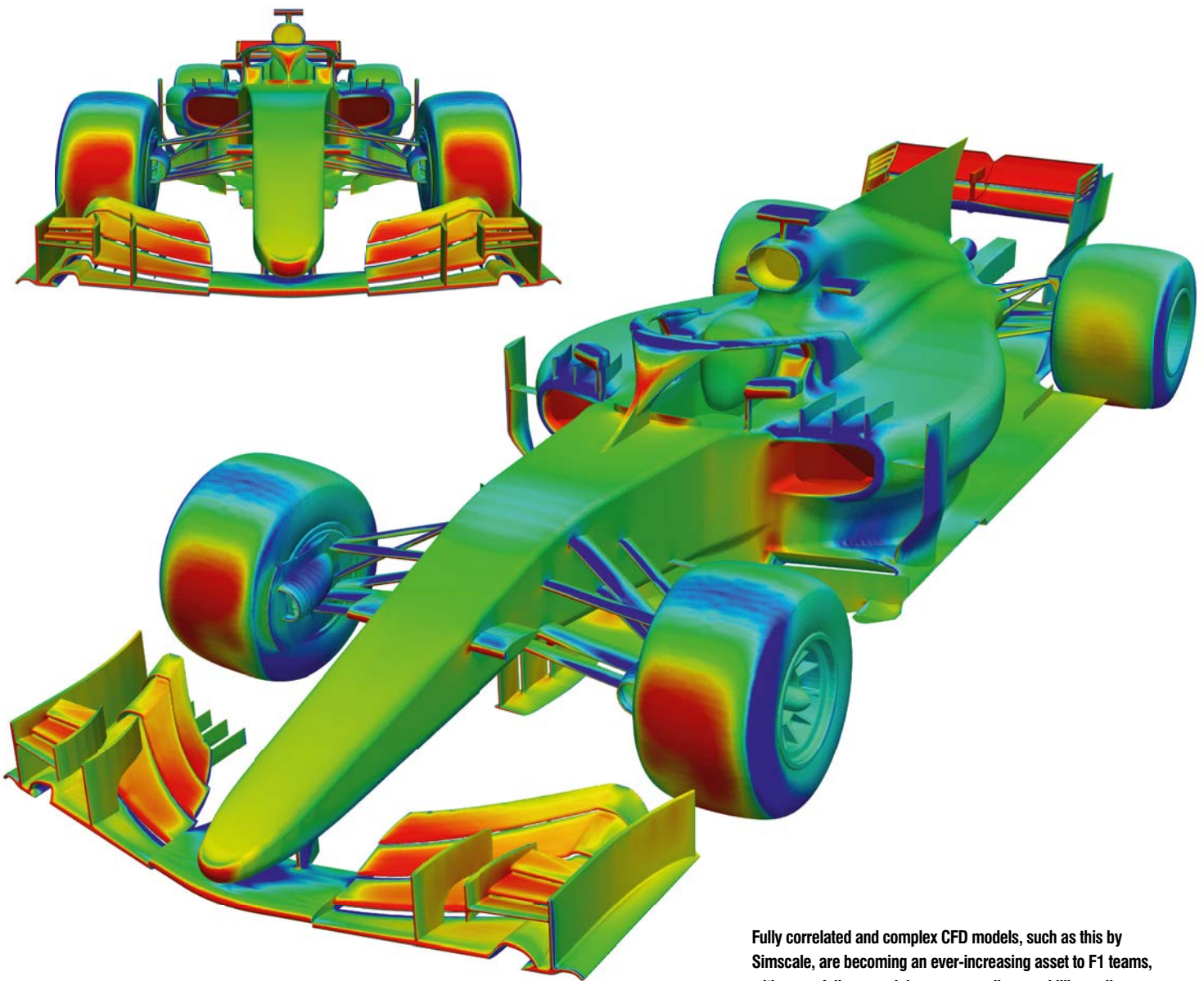

Fully correlated and complex CFD models, such as this by Simscale, are becoming an ever-increasing asset to F1 teams, with some full car models now exceeding one billion cells

# Every restriction simply triggers teams to exploit the loopholes, and optimise designs and working practices to maximise performance





# CD34

THE BEST JUST GOT  
BIGGER



- > 8in widescreen LED backlit TFT
- > 9 tri-colour shift lights
- > 200Mbyte data-logging memory
- > Fully configurable layouts
- > Up to 100 display pages



[www.gems.co.uk](http://www.gems.co.uk)

# THINK Automotive



Think Automotive are specialists in oil cooling systems and all aspects of vehicle plumbing. We are the manufacturer and distributor of Mocal® products.



We stock and distribute the finest automobile products, such as oil coolers, hosing, hose fittings, filler caps, water pumps, oil pumps, heaters, gauges and more.

Tel: 020 8568 1172

Web: [www.thinkauto.com](http://www.thinkauto.com)

Email: [info@thinkauto.com](mailto:info@thinkauto.com)





A typical HPC cluster from Boston. With each new generation of compute chip delivering up to 20 per cent efficiency improvement the increased capacity of modern CFD clusters means that teams can now have an extra 200 runs, as opposed to 20 back in 2009

flops/cycle rating. These older systems were coming to the end of their life and were no longer supported by Intel or AMD.

Clearly the FIA had to do something, and the target was to introduce a new regulation which aligned the Formula 1 aero departments more closely with the wider CFD industry as well as allowing teams to upgrade to more modern, supported technology. This resulted in the 2018 CFD restrictions and a move from TFLOPS to Mega Allocation Unit hours (MAUh) as defined by the following equation:

$$AUh = \left( \frac{NCU \times NSS \times CCF}{3600} \right)$$

$$MAUh = AUh \times 1,000,000$$

**Where:**

AUh = Allocation unit hour

NCU = Number of processing unit cores

NSS = Number of solver wall clock seconds elapsed during the run

CCF = Peak processing unit clock frequency in GigaHertz

Effectively this a very similar measure to TFLOPS but without the reliance on flops per cycle, hence removing the barrier to upgrading to newer, better supported, technology. The FIA commissioned an independent study to be carried out in order to set the regulation limit with the intention of giving parity between the old regulations and the new ones. The link to

WON was retained and a parallel regulation was introduced with the aim of allowing teams to continue using their old systems if they wished, without too large a performance penalty – at least that was the intention.

Boston Ltd has been specialising in high performance computing (HPC) in a wide range of sectors for over 25 years. In 2017 it formed a new partnership with Tim Milne of UniFi Engineering Services Ltd (UniFi) and Dr Lee Axon of Computational Engineering Ltd (CE). Milne and Axon have extensive Formula 1 experience, most recently at Manor F1 where they were head of aerodynamics and head of CFD correlation respectively.

This group combined Boston's extensive HPC technical knowledge with UniFi's and CE's F1 aerodynamics and CFD experience to provide the F1 teams with a comprehensive benchmarking of the new AMD EPYC and Intel Skylake Platforms. They were able to use all the main F1 CFD codes with models aligned to F1 methodologies and HPC hardware set-ups to extract the maximum possible performance from the new regulatory environment.

**Node to joy**

The project began in August 2017, by which time Boston Ltd was one of the first companies worldwide to have invested in its own eight node dual socket AMD EPYC system based on the EPYC7601 32 core chips and a similar eight

node system based on the Intel Skylake 8176 Platinum 28 core chip. The group also had access to a smaller four node Intel Ivybridge HPC which was used to provide a baseline of the performance gains that teams could achieve by upgrading from their older systems to the new hardware. This allowed Boston to benchmark its own internal CFD model across a range of CFD codes with a wide variety of hardware set-ups. The systems were all set up with the very latest in networking fabric, up to date operating systems and storage solutions, ensuring that the results obtained would be aligned to the expectations of the F1 teams.

**Hot chips**

Following the benchmarking of the older Ivybridge system, a number of options within the AMD EPYC range as well as the Skylake 8176 chip were evaluated as single node tests to gain an initial assessment of the various different chips available in each family, as well as some insight into the time/iteration performance benefits of different options such as the turbo mode. This also ensured that a clear understanding of the raw performance of the compute chip was gained and that the results were not clouded by any networking issues which could be useful later in the process when trying to understand the results on the larger scale multi-node systems. The performance gains over the older Ivybridge system were

**The new method that was introduced at the start of this year is a very similar measure to TFLOPS but without the reliance on flops per cycle**

Motorsport Essentials

Gauge Fittings

Oil, Fuel & Water Hoses

Silicone 3 PLY & 4 PLY & Vacuum Hoses

Linkage Parts & Suspension Rod Ends

Brake & Clutch Hoses, Spares & Fittings

Hose Clips, Joiners & Fittings

Fan Thermostat Switch Kits

Electrical Accessories

Suppliers of Race, Fast Road, Classic & Commercial Products

Tel: 01933 778335

[www.LMAautoparts.co.uk](http://www.LMAautoparts.co.uk)

Fax: 01933 778341

[sales@LMAautoparts.co.uk](mailto:sales@LMAautoparts.co.uk)

**DOCKING**  
engineering  
Advanced Cooling Systems

Water Radiators  
Intercoolers  
Oil Coolers  
Heat Exchangers  
System Design  
Ancillary Products

Manufactured to your requirements  
by the UK's leading supplier.

Email [info@dockingengineering.com](mailto:info@dockingengineering.com)

Tel +44 (0) 1327 857164

Fax +44 (0) 1327 858011

Web [www.dockingengineering.com](http://www.dockingengineering.com)



Certified to CAA & AWS  
Welding Standards

Unit 15 Silverstone Circuit  
Silverstone, Northants  
NN12 8TL, United Kingdom

# INSIDE THE **ICON**

Produced with **unique access** to a **race-winning MP4/4 chassis**, this **McLaren-approved manual** tells the **full story** of the **design, engineering** and **operation** of the **most dominant car in F1® history**.

AVAILABLE AT [HAYNES.COM/MOTORSPORT](http://HAYNES.COM/MOTORSPORT)  
AND ALL GOOD BOOKSHOPS

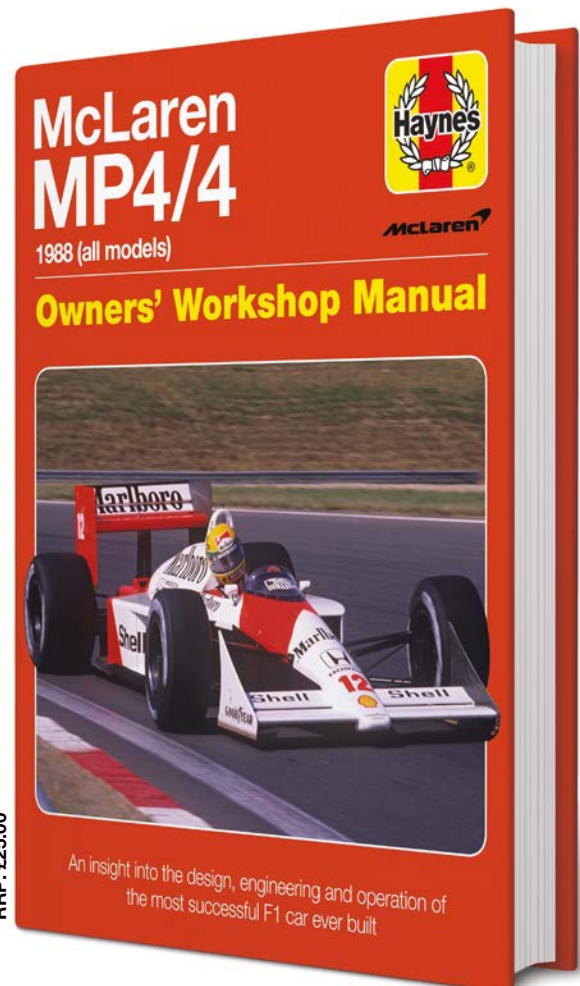

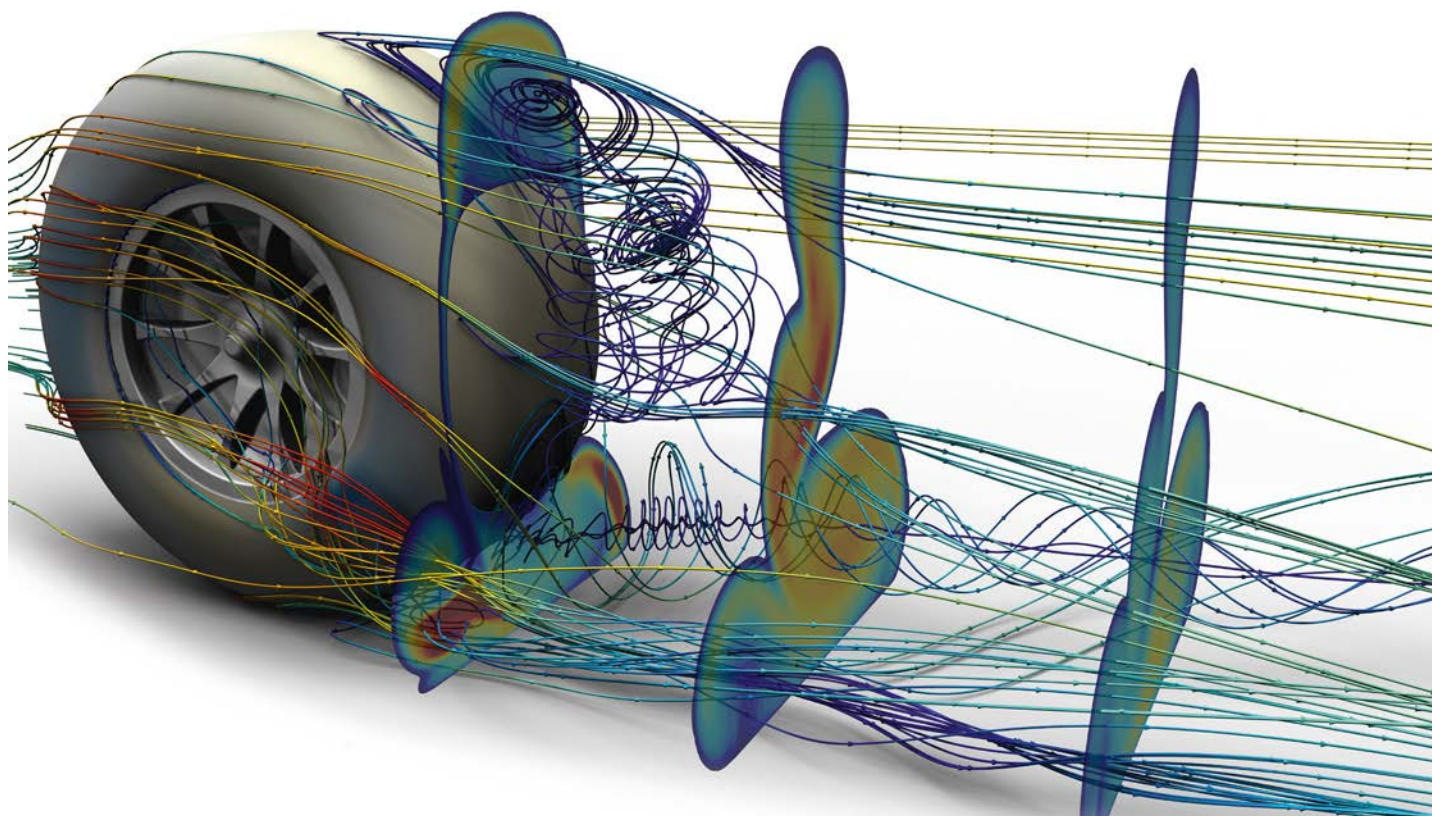

SIEMENS

Despite the efforts of the FIA to restrict the costs of CFD work, Formula 1 teams can now complete up to 1500 simulations each week on a typical model of around 200 million cells

very quickly evident and it soon became clear that the teams would all be forced to upgrade their HPC systems in order to remain competitive, which is the nature of Formula 1. But this upgrade was extremely expensive. This is not what the FIA had been aiming for, but reflects how quickly the HPC industry moves forward with the Formula 1 environment forced to follow suit to remain competitive.

Once testing migrated onto the full, multi-node systems the full optimisation process could begin. This involved running the same model over a wide range of different set-ups, including options for memory bandwidth per core used and process bindings. The key at this stage was for the group to develop an understanding of the efficiency vs performance of each compute system – ideally each compute chip in each family from Intel and AMD.

In reality UniFi and CE were able to use their experience in the industry to limit the testing to the most likely candidates for Formula 1 operations and Boston used its extensive links in the HPC industry to gain access to relevant systems for benchmark testing. Once a small range of AMD and Intel compute chips had been selected, the focus was on understanding how they performed against the Formula 1 regulations. This required repeating the CFD simulation of their Formula 1 car on a range of different HPC sizes and set-ups.

For example, the CFD case will be repeated on the same HPC system but testing the simulation on 48, 96 and 192 cores. It was accepted that the case being run on 96 cores will take slightly longer than half the time of the case on 48 cores and slightly less than half the case being run on 192 cores – so there is an element of inefficiency by running on an increasing number of cores. However, it is in the teams' interest to complete their CFD simulations quickly in order to allow their iterative aerodynamic development programmes to continue as quickly as possible – so it's a trade off and one which was vitally important for the Boston group to understand.

### Core values

The next step was to understand the impact of leaving some of the compute cores dormant, as previously mentioned. This is an approach quite alien to most of the CFD industry (why would you buy compute cores and then not use them?) but something that was already well known to deliver regulatory efficiency in the F1 environment, if you could afford it.

Tests were completed leaving a range of the cores dormant in order to give less operational cores per memory channel, and thus increasingly improving the memory bandwidth available to the CFD simulation. The conclusion of this benchmarking study

## It soon became clear that the teams would all be forced to upgrade their HPC systems in order to remain competitive

delivered performance gains which would enable the F1 teams to run approximately twice as many CFD simulations per week in 2018 than they had been able to in 2017 (for the same wind tunnel operation). Furthermore, the teams would complete each of these simulations in approximately half the time that was required under the 2017 regulations.

### Formula 1 specific

Much of this optimisation is not relevant to the wider CFD industry, but is now considered basic within the Formula 1 teams. The next step was for the Boston group to really exploit the expertise available from the UniFi/CE group. The details of this remain confidential, but it enabled the group to develop solutions which delivered even more performance for the F1 teams, and a further 20 per cent reduction



**Much of this optimisation is not relevant to the wider CFD industry, but it is now considered basic within the Formula 1 teams**

# Vacuum processing of Additive Manufactured components and materials

including:

- Inconel
- Titanium
- Aluminium
- Stainless
- and more alloys



**Tamworth Heat Treatment**

7 Darwell Park, Tamworth, Staffordshire, England. B77 4DR.

Email: [sales@tamworth-heat.co.uk](mailto:sales@tamworth-heat.co.uk)

Tel: (+44) 0 1827 318 030

# PEGASUS



# Beta

Exclusive North American Motorsports Distributor for Beta Tools



Stocking distributor of silicone hoses

US importer of Jabroc® skid plate sheets



Stocking distributor of MS21071 Apex Joints (all sizes, 1/4" to 1 1/4")

*... and much more!*

**Pegasus Auto Racing Supplies** • New Berlin, WI USA  
800-688-6946 • 262-317-1234

**PegasusAutoRacing.com**

*Racers serving racers around the world since 1980*



# HCI

S Y S T E M S

Precision manufacturing of LV & HV Electrical Wiring Harnesses for:

- ▶ F1
- ▶ LPM1
- ▶ LPM2
- ▶ WRX
- ▶ FE
- ▶ GT4
- ▶ Automotive

...your global partner for

**Electrical System Solutions**



HP ELECTRONIK

[www.hci-s.com](http://www.hci-s.com) - 01952 825002 - [info@hci-s.com](mailto:info@hci-s.com)

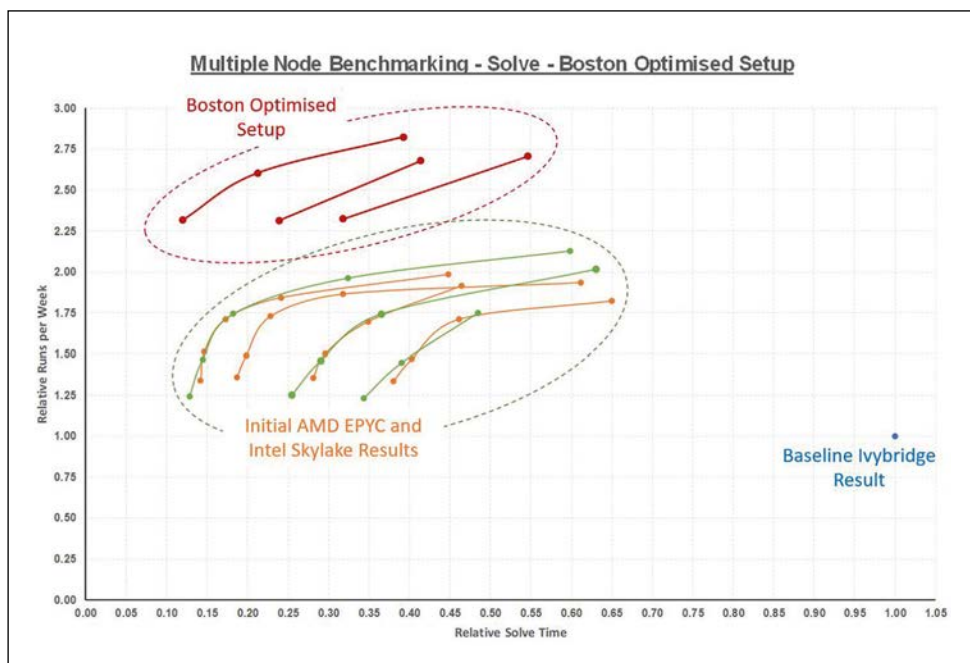

The benchmarking study concluded that teams would gain a huge performance advantage if they purchased a new multi-million pound system because they would have twice the CFD capacity of 2017 – this was not the aim of the regulations

in solve times was extracted from the same CFD set-up, which also increased the CFD throughput by the same 20 per cent.

Finally, as the benchmarking study neared its conclusion Boston worked with AMD to further optimise for the requirements of F1 by increasing the memory bandwidth whilst retaining a relatively low base clock speed.

‘AMD EPYC delivers exceptional levels of performance in a number of workloads, including high performance computing CFD applications’, explains Roger Benson, the senior director of the Datacenter Group, EMEA, AMD. ‘We are excited to be working with Boston on their automotive engineering focused platforms and improving the efficiency of aerodynamic testing for their customers.’

### The results

The stated targets of the FIA for this change in regulations was to enable the F1 teams to upgrade from their Fangio and Ivybridge systems to the latest technology available, but without a clear performance pressure to do so, and with the aim of better aligning the F1 industry with the wider CFD industry.

Firstly, it is clear that all the F1 teams have upgraded to a new system, with most teams having done so ahead of the regulatory change date of 1 January 2018. So, the first aim has been achieved – the Fangio and Ivybridge systems that the teams were operating are now obsolete. However, the benchmarking work completed by Boston clearly demonstrates

the huge performance advantage available by purchasing a new multi-million pound system, which was not the aim of the new regulations.

Furthermore, the impact of the increase in CFD capacity available to the teams under these new regulations only serves to increase the financial pressure on the teams and in particular the pressure to increase headcount within the aerodynamics departments as the CFD capacity available increases. Not only have they effectively been required to invest in new HPC architecture in order to remain competitive, but the incentive to adopt future improvements in chip technology has now only increased. How so? The benchmarking work completed by Boston suggests that teams are now able to complete between 1000 and 1500 CFD simulations per week based on a typical CFD model of around 200 million cells. Teams may elect to ‘trade’ some of this capacity for larger models (some teams run CFD models approaching one billion cells) or better quality models (transient simulations rather than steady state). But the key point is that the F1 HPC regulations have now given the teams twice as much capacity to play with than in 2017.

### Step change

Typically each generation of compute chip that is released by AMD/Intel delivers around 10 to 20 per cent improvement in efficiency. Back in 2009 this would give the teams an extra 10 to 20 CFD runs per week, and therefore would not easily justify the large cost in

**The FIA focus remains on reducing wind tunnel reliance and delivering greater CFD capacity in exchange, and the current regulations deliver that**

replacing their CFD clusters. In 2018, with the massive increase in capacity, the same 10 to 20 per cent improvement available from each evolution of compute chip technology is 100 to 200 runs – that is the same as the total capacity of the systems in 2009.

Is this a bad thing? Arguably not. HPC systems are much cheaper now than they were back in 2009. The FIA focus remains on reducing wind tunnel reliance and delivering greater CFD capacity in exchange, and the current regulations deliver that.

However, does it help to level the playing field between the high budget teams and the low budget teams? Does it help to encourage new teams into the sport? And does it make the working practices within the Formula 1 aero departments more aligned to the wider CFD industry?

With AMD releasing its second generation of EPYC chip in 2019, the reaction of the teams will be interesting. Will they all upgrade immediately? Or will the well-funded teams take the opportunity to get a performance advantage from the new technology that the smaller teams cannot afford?

**Boston, UniFi and CE continue to develop their partnership with a focus on the F1, motorsport and automotive industries across all CFD codes and working practices. For more information visit the websites at: [www.boston.co.uk](http://www.boston.co.uk); [www.unifimotorsport.com](http://www.unifimotorsport.com); [www.computationalengineering.co.uk](http://www.computationalengineering.co.uk)**

**When AMD releases its second generation of EYPC chip in 2019 the reaction of the Formula 1 teams is going to be very interesting**

# Keep Prototyping, Start Producing



Beautifully engineered **3D Printed parts** for motorsport: Prototypes, Wind-tunnel Models and Production Parts.

**Carbon SLS & Graphite SLS and SLA technologies.**



Visit [graphite-am.co.uk](http://graphite-am.co.uk) or contact:

[sales@graphite-am.co.uk](mailto:sales@graphite-am.co.uk) **01296 482673**

We are proud Product Sponsors of Bloodhound SSC

# OUTPERFORM THE COMPETITION

WITH FASTER, MORE ACCURATE VEHICLE TESTING



ACCELERATE EVERY STAGE OF DESIGN AND DEVELOPMENT WITH TOTALSIM US:

- Streamline pre-processing, post-processing, data management and more with automated CAE processes and workflows
- Perform highly-accurate CFD simulations with intuitive, web-based applications tailored to automotive designs
- Tap into our racing experience for on-track, wind tunnel and bench testing, performance mapping and aerodynamics analysis

EMPOWER YOUR TEAM WITH THE TOOLS TO OVERCOME CHALLENGES AND DELIVER HIGH-POWERED RESULTS.

CONTACT US AT 614.255.7426 OR [INFO@TOTALSIM.COM](mailto:INFO@TOTALSIM.COM) TO LEARN MORE.

[TOTALSIM.com](http://TOTALSIM.com)

Power steering packaged to fit your race car

# WOODWARD

## ONE or HUNDREDS

*Pre-engineered solutions, short lead times, and reasonable cost... just download a Type CF design worksheet and e-mail us your requirements.*

Custom rack lengths  
Travel up to 135mm  
Left or right hand  
30 valve profiles  
3 pinion angles  
7 gear ratios  
2 piston sizes



AND we make the world's best race car steering u-joints.

[woodwardsteering.com](http://woodwardsteering.com)

## Interested in Motorsport Aero? Want to learn from an experienced F1 Aero?



Compete in teams against students from across the world

No prior CFD or Aero experience required

Win prizes from our project partners, including motorsport aero work experience

Apply today at:

[www.unifimotorsport.com/racing](http://www.unifimotorsport.com/racing)

 [unifi\\_racing](https://www.instagram.com/unifi_racing)

 [@unifi\\_racing](https://twitter.com/unifi_racing)

# THE PERFECT CHRISTMAS GIFT

SUBSCRIBE FOR FAMILY AND FRIENDS

The Christmas gift that arrives all through the year



UK	USA	AUSTRALIA	EUROS	REST OF WORLD
<b>£46.50</b> (usually £89)	<b>US \$83.95</b> (usually US \$140)	<b>AUD \$114.95</b> (usually AUD \$195)	<b>€74.95</b> (usually €115)	<b>£64.50</b> (usually £100)

 [www.chelseamagazines.com/CRCEXM18](http://www.chelseamagazines.com/CRCEXM18)

 01858 438 789 quote CRCEXM18

**DIGITAL EDITION ALSO AVAILABLE FOR £36.50**  
for tablet, smartphone and desktop.



# Making tracks



Achieving close racing in the World RX Championship is not just about equalising car performance. Clever track design can be the difference between entertainment and boredom

**T**he combination of circuit racing, rallying and drag racing that is World Rallycross (RX) is fantastically entertaining. Add to that the technical challenges of setting up a car for both asphalt and dirt surfaces, while coping with the impact of jumps, and faster-than-F1 acceleration times, and it is, for many, the perfect balance between engineering and entertainment.

World RX is also arguably the fastest growing category of motorsport in the world, and with growth comes expansion. Last year, the World RX Championship concluded in South Africa for the first time, while this year saw the introduction of two new venues; Silverstone in the UK, and COTA in the USA.

'There are two or three other territories that we are talking to seriously as well as a few additional European ones, but we don't want to go to a 16-round calendar,' says Paul Bellamy, managing director of FIA World Rallycross and Global Head of IMG Motorsports. 'We've talked

**When a race circuit requires jumps, stretches of asphalt plus sections of dirt or gravel, the design challenge gets a whole lot more complicated – we spoke to the experts about the science behind the creation of World Rallycross standard tracks**

By **GEMMA HATTON**

to nine promoters in China. Then there is the Middle East, and there's an opportunity in South America, but it is about balancing the new rounds with those we have already got.'

So with new venues popping up each year, how do you go about designing these RX tracks? Where should the 'Joker' lap be? How do you manage the behaviour of the dirt surface for driveability? As ever in engineering, there is a lot more to this than meets the eye.

'Historically, rallycross tracks were built by stripping off the layer of topsoil and then they would go racing,' explains Dafydd Broom, design director at Apex Circuit Design, which was behind the development of the Barcelona, Bikernieki (Latvia), Hockenheim and Cape Town World RX tracks. 'However, the demands of modern RX has led to the development of unsealed surface materials to cater for this international and highly commercial series.'



**'The demands of World Rallycross has led to the development of unsealed surface materials to cater for this international series'**



There is an amazing amount of science that goes in to developing the perfect type of dirt for RX cars to race on. The aim is to make a loose but stabilised surface with minimal dust

When Apex first began working with IMG to develop these new RX tracks, it was asked to supplement the FIA guidelines with additional IMG self-imposed standards that aimed to address issues such as jump design, track limits, venue branding and circuit presentation.

## Loose talk

One of the primary review points was the specification of the unsealed surface. As specified by the FIA, 60 per cent of each RX track must be a sealed surface with the other 40 per cent an unsealed surface. Whilst the sealed surface is commonly asphalt, the unsealed has taken many forms over the years resulting in varying degrees of performance, and it was this variance that IMG wanted to address.

‘The first key performance specification was with regard to surface durability,’ Broom says. ‘Often the unsealed surface of the track can rut which is where the loose material ends up creating channels in the track which the tyres slip into and this can generate an

uneven surface and is horrible to drive on. The RX supercars are very powerful, they generate 600bhp and have the ability to accelerate from 0-60mph in less than two seconds. This performance results in a large load being put through the surface of the track that can cause increased wear, especially for the unsealed surface, that often manifests itself in rutting.’

Although this may seem part of the driver challenge, poor surface durability poses an operational challenge and risk. With more than 80 races across a single weekend, the track needs to remain consistent with as little track maintenance between races as possible.

‘The second performance specification centred around presentation and safety,’ says Broom. ‘Unsealed materials up until now have traditionally been quite loose and, when wet, very dirty. This can result in material being swept up by the vehicles and then projected behind causing drivers in their wake to lose visibility or even damage their cars, whilst posing a potential risk to spectators in close

proximity to the track and poor presentation of the series vehicles and sponsors.’

Therefore, a new unsealed surface specification was developed for the sport that not only met all of IMG’s criteria, but also allowed for a variance across the series due to the different constructions required to suit the varying ground conditions around the world.

## Solid ground

Essentially, the modern specification for the unsealed surface is one that utilises soil stabilisation techniques that result in a surface that is as hard as concrete, without being classified as a sealed surface.

The first stage of building a track is to conduct a geotechnical investigation in the proposed location to understand the properties of the material found on site and to understand what sort of stabilisation technique would be most appropriate to those specific ground conditions.

‘For example, if it is a clay based material, we can mix it with varying degrees of lime to create a hard surface so it becomes a very stable material,’ says Broom. ‘When we don’t have that clay based material we can make use of a concrete binder to create that hard surface with the even and consistent wear that you see on modern circuits.’

With every passing racecar, the surface slowly and evenly deteriorates, generating a

**Although it may seem part of the challenge for the driver, poor surface durability actually poses an operational challenge and risk**



# HiSPEC

BRAKES UK

WWW.HISPECMOTORSPORT.CO.UK

CONTACT US FOR A TAILOR-MADE BRAKE PACKAGE

PHONE: 01322 286850

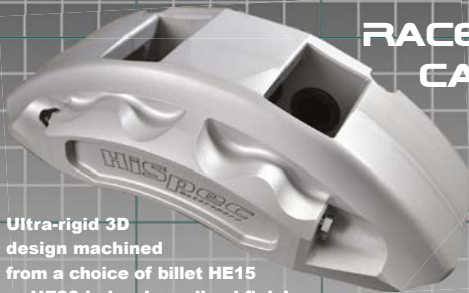

## RACE CALIPERS

Featuring internal fluid transfer and the option of HiSpec dual heatsoak pistons.

Ultra-rigid 3D design machined from a choice of billet HE15 or HE30 in hard anodised finish.

## ROAD CALIPERS

Our extensive range of road calipers feature dust seals and internal fluid transfers. Machined from Billet HE30.

Available in a range of colours and options to suit your needs.

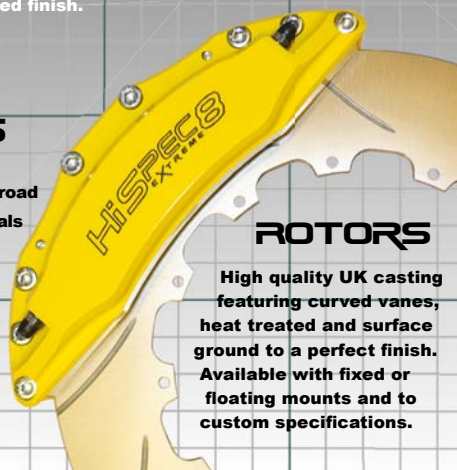

## ROTORS

High quality UK casting featuring curved vanes, heat treated and surface ground to a perfect finish. Available with fixed or floating mounts and to custom specifications.

motorsports quality  
**ROD ENDS, SPHERICAL BEARINGS**  
and MS spec. **UNIVERSAL JOINTS**



**AURORA®**  
**RODOBAL®**

inch  
metric

**BELDEN®**  
**universal**  
**Seals-it®**

most extensive stock in Europe, US / EU parts  
basic / regular / top product lines,  
flexible service, worldwide delivery  
support service to OEMs and national distributors

**ROD ENDS ACCESSORIES:**  
side seals, protection boots,  
jam-nuts, right-hand and left-hand  
grooved bearings staking tools

**Getecno** Ltd. - ITALY

fax +39 010 835.66.55

e-mail: [info@getecno.com](mailto:info@getecno.com)

contacts in English, Deutsch, Français, Italiano

# Antigravity Batteries

The Worlds Smallest, Lightest, Most Powerful  
Race Car Batteries

## Lithium motorsport batteries



- Designed and Manufactured in the USA
- Ultra Powerful
- Super Light
- Multiple Ah options
- Now available with **restart\*** technology

Visit our website for full specifications

Tel: 01702 301664  
[www.antigravitybatteries.net](http://www.antigravitybatteries.net)

APPROVED BY  
MOTOR SPORTS ASSOCIATION  
UNITED KINGDOM **MSA**

\* Restart batteries made in China

**‘If it is a clay based material we can then mix it with varying degrees of lime to create a hard surface, so it becomes very stable’**

fine loose material that settles on the surface and therefore reduces its frictional coefficient, although a light sweeping between races can brush this away before it causes issues.

‘Ideally you need to stabilise the top 25cm of soil so that it remains robust, but loose, so that the car feels like it is on a loose surface. The trick is how you achieve that whilst minimising any dust that is thrown up,’ says Karl O’Sullivan, who helped IMG develop tracks before becoming team manager at GCK World RX Team. ‘If built correctly, that 25cm layer of topsoil should last between three to five years. Below that is a sub base which can consist of a wide variety of additives and binding agents all mixed together. Ultimately it will depend on the specific properties of that soil and samples will be analysed in a lab to create the unique magic potion that will stabilise that surface correctly.’

To manage dust levels, natural materials such as water or man-made additives such as Dustex, often used in quarries, is sprayed on to the unsealed surface to suppress the dust.

You may think that because the track is hard with low wear, track evolution doesn’t exist, but that’s not the case. ‘Actually, because the material is so hard, the unsealed surface does in fact rubber up,’ says Broom. ‘So there is a

Figure 1: A typical track design drawing

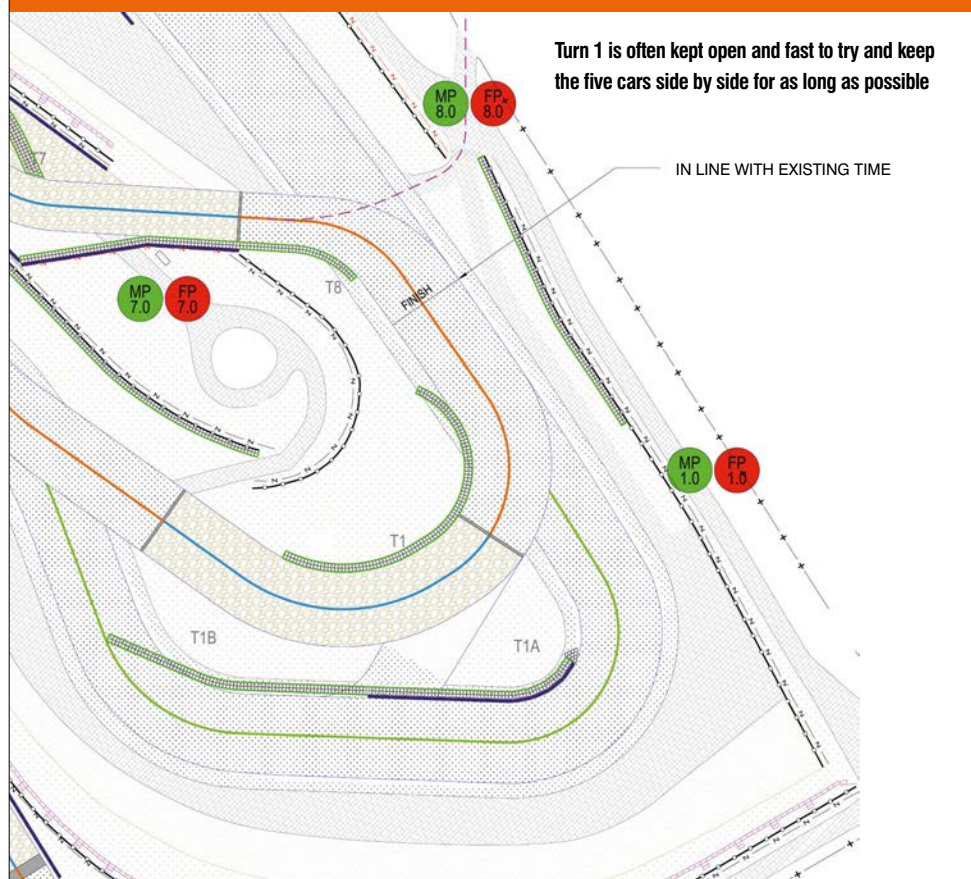

period of time where more rubber gets laid on the track and the rate of this depends on track temperature. For example, the track in COTA that we designed was already rubbering up during the tests, especially through the corners. This will create a constantly changing track dynamic that drivers will have to react to.’

### Crossing the tracks

So that is the science behind the surfaces, but what about the actual track layout? As World RX is an FIA championship the governing body has standard guidelines that track designers have to comply with for their circuit to obtain a racing

license. These guidelines specify parameters such as the distance between the start line and the first corner, the width through the first corner and the track width.

Usually, turn one is kept as open and as fast as possible to try and keep the cars side by side and avoid a single line, as this draws out the cars into single file, which is not ideal for such short races (Figure 1). However, in cases like Riga, this could not be achieved as the long straight would be too high and therefore require a very large run-off area, which was not possible. So, to slow the cars down, a small chicane was added.

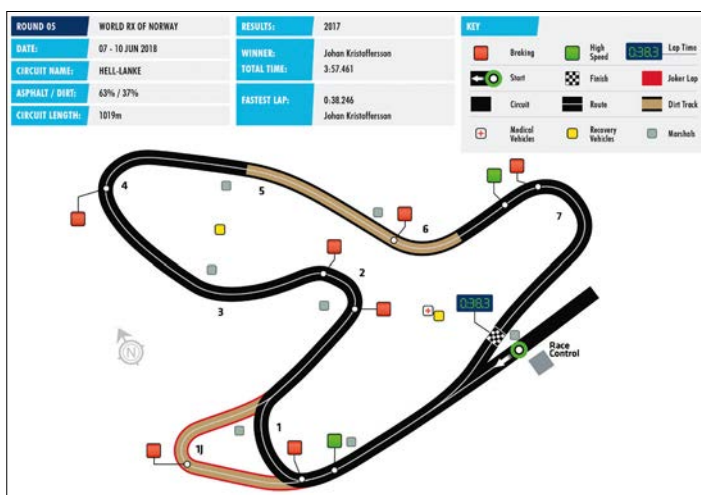
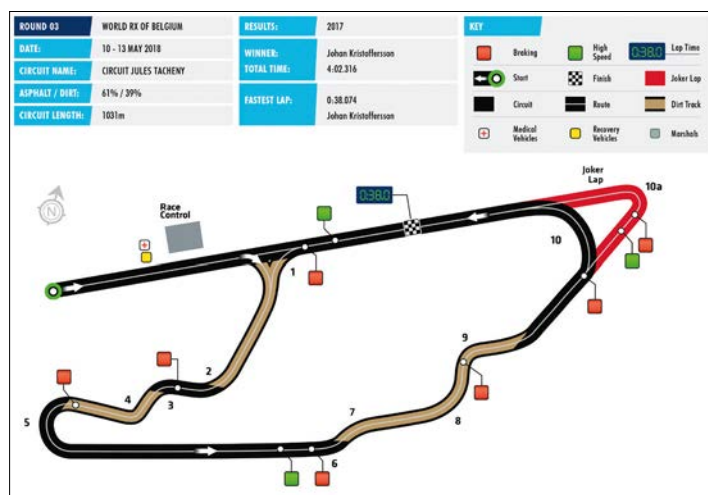

The ‘Joker’ lap is peculiar to World RX. It requires cars to take one longer lap via an extension. Some say that to maximise the excitement this should be towards the end of the lap, such as in Belgium (left), to have cars battling for position across the finish line; rather than how it is in Norway (right) where you can end up with what seems like two different races

www.ProFabrication.com  
*"Quality that Wins"*



CNC Flanges

Custom Headers  
 Mandrel Bends  
 Merge Collectors  
 Straight Tubing

**PRO FABRICATION**  
 Racing Exhaust Systems  
 704-795-7563

Tailor Made Exhaust From CAD to Manufacturing

## Welcome to the Pressure Scanning REVOLUTION



Compact, Fast & Accurate  
 Pressure Scanner

EvoScann® P-Series is a highly-miniaturised pressure scanner designed specifically to meet the stringent demands of the aerodynamic testing industry:

- **SMALL** <15g with compact dimensions, can be located in tight spaces
- **PLUG and PLAY** no requirement for a remote converter or other hardware, transmits directly to the test article's central processing unit
- **ACCURATE** using high-performance piezo-electric pressure sensors for the highest accuracy



For full details call  
 quoting RTECH:  
 +44 (0)1264 316470  
 or visit [www.EvoScann.com](http://www.EvoScann.com)

## Travel Agents



Suspension travel is essential. Without quality bearings and rod ends you're bottoming out. Aurora's been your travel agent for over 40 years.



Aurora Bearing Company  
 901 Aucutt Road  
 Montgomery IL. 60538



Complete library of cad drawings and 3D models available at  
[www.aurorabearing.com](http://www.aurorabearing.com)

Ph: 630-859-2030



Specialists in  
 Motorsport Hydraulics & Fluid Transfer

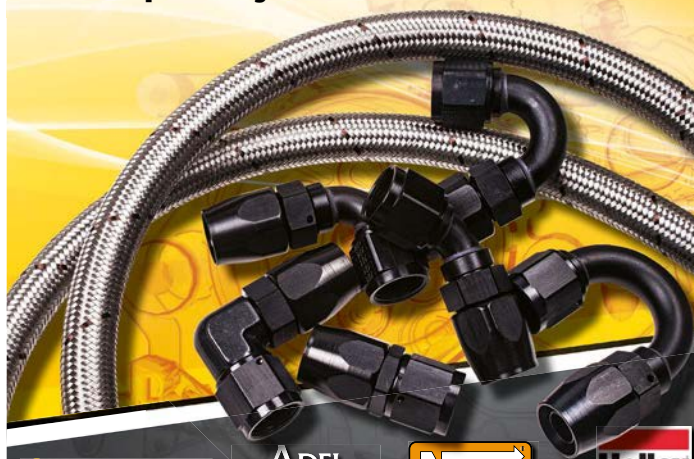

Earls Performance  
 15/16 Silverstone Technology Park  
 Silverstone, Northants.  
 NN12 8TL

01327 858 221  
[sales@earls.co.uk](mailto:sales@earls.co.uk)  
[www.earls.co.uk](http://www.earls.co.uk)

And then there are jumps. 'Where you have lots of flexibility is the position of the jumps,' says Broom. 'If you are building a green-field track then you would look at the natural elevation changes that already exist to develop jumps that challenge the drivers. However, most tracks are retrofits to other circuits, so you have to artificially add them in which limits the geometries and style of jumps you can create.'

## New challenges

As IMG continues to grow and improve World RX to become a renowned worldwide form of motorsport, naturally races are held at bigger and better venues. For example, this year's UK round saw the controversial move from Lydden Hill to Silverstone because World RX had simply outgrown this historic venue. This adds to the list of challenges that modern RX track designers have to face, because retrofitting a RX track to the requirements of the overall circuit is by no means an easy task. 'When you have to adapt a circuit for RX you have to be sympathetic towards the Monday to Friday operations of that circuit,' says O'Sullivan. 'The challenge is to develop a circuit which feels permanent during the World RX weekends, but is temporary in the eyes of the wider circuit so that you are not intruding on their day-to-day activities such as a Formula Ford experience or motorcycle track day.' This can therefore dictate elements such as the height of jumps or any banking.

Another thing which sets World RX apart from other categories is the 'Joker' lap. This is an extended lap which each driver has to take once during each race and needs to be designed to add at least one second to the lap time. To achieve the most exciting racing, the 'joker' layout is usually put close to the end of the lap, so that if drivers choose to take their 'joker' on the last lap, they come out alongside the others, battling for position as they cross the finish line.

'There are different thoughts on this but I feel having the 'Joker' lap towards the end of the lap provides more entertainment,' says O'Sullivan. 'There are a number of circuits where the 'Joker' lap is at Turn 1, so in a five car race two can take it while the other three continue around the normal track and effectively you get two different races. I prefer seeing all five cars racing alongside each other for at least one lap before anyone decides to take the 'joker'.'

'You need to make sure that the merge is parallel with the cars on the main track and that everyone is travelling at a reasonable speed so that it really does go down to the last corner, which is great from an entertainment perspective,' O'Sullivan adds.

**'When building a green-field track you would look at the natural elevation changes that already exist to develop the jumps'**

**Figure 2: A simulation of the required run-off areas**

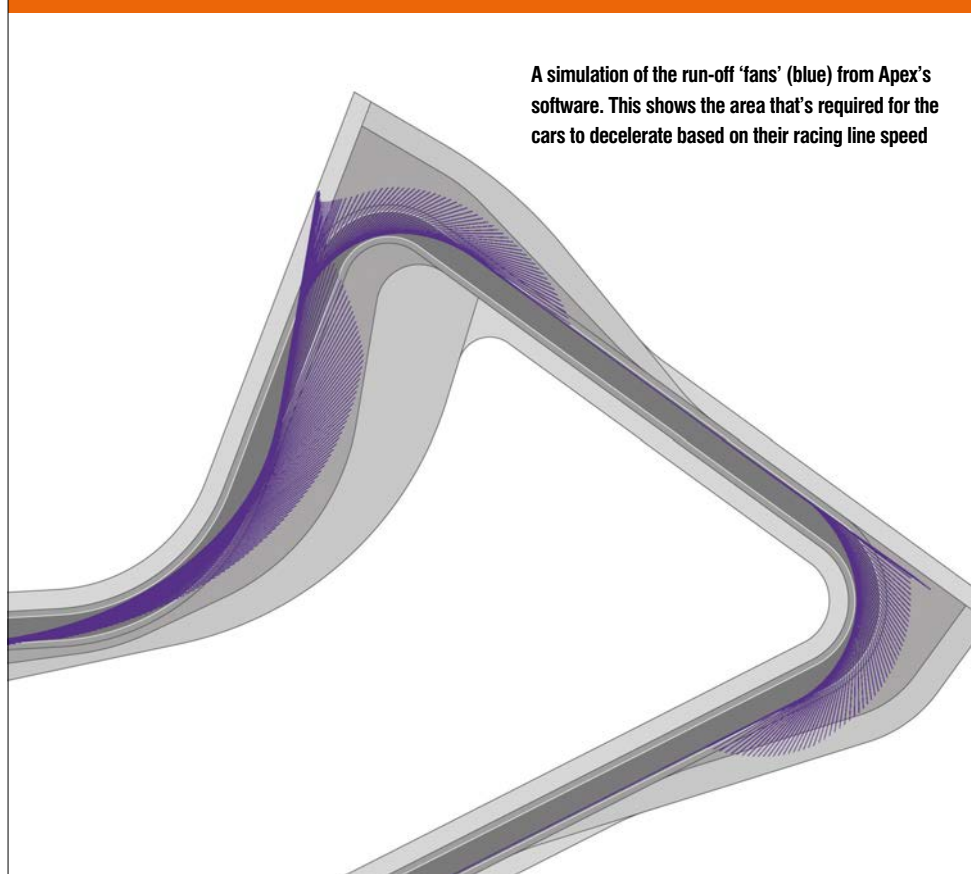

A simulation of the run-off 'fans' (blue) from Apex's software. This shows the area that's required for the cars to decelerate based on their racing line speed

To help with the design process, Apex has developed a unique software programme which effectively utilises Matlab code to simulate the safety of its designs, which can then be modified accordingly. Data points from the CAD model of the track are imported into Matlab and real car data is used to define the racing line. This allows the horizontal and longitudinal accelerations and speeds of the vehicle to be determined at each point around the track.

Once these speeds are defined, the software then simulates how long it will take the vehicle to decelerate in the event of an accident and therefore how long the run-off areas need to be. Run-off areas can either be grass, gravel or asphalt and the FIA has specified guidelines based on tests which define the deceleration rates of a vehicle on each of these types of medium. Asphalt decelerates a car quicker than gravel, and grass takes the longest and therefore requires a large amount of space. The simulation then generates run-off 'fans' (Figure 2) which dictate the dimensions of the run-off areas depending on the selected medium and so the geometry of the track can start to be tweaked to meet the safety and cost requirements.

'If it's not possible to have the space required for grass run-off areas, for example, then we change the medium to gravel and if we are still in the barrier then we add in more asphalt,' Broom says. 'In some cases you still won't have the space for the required run-off areas so then you use energy dissipating barriers. Our software is extremely sophisticated and it allows us to simulate designs quickly. So as soon as a line is put on the plan, we are able to quickly CAD up the track and have a simulation done within 10 minutes.'

## Flip side

The vertical geometry of the track is also another consideration. 'You want to try and minimise the opportunity for cars to flip due to aerodynamics, like we have seen at Le Mans in the past. Again, the FIA have put in guidelines to address this issue,' says Broom. 'For new circuit venues the vertical elevation of the centreline of the track should be proportional to the speed of the car. By working this out, our simulation then gives us the maximum radius that we can have for vertical transitions. This is where it is hard to get some of the qualities of the classic tracks into modern ones, because classic corners such as the Corkscrew at Laguna Seca are very much outside of the current FIA guidelines, which is what makes them so special. We try to push the boundaries and make them as extreme as possible within the rules to improve the driver experience, but obviously safety is paramount.'

# HiSPEC BRAKES UK

WWW.HISPECMOTORSPORT.CO.UK

CONTACT US FOR A TAILOR-MADE BRAKE PACKAGE

PHONE: 01322 286850

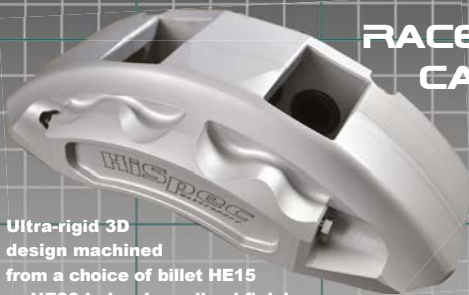

## RACE CALIPERS

Featuring internal fluid transfer and the option of HiSpec dual heatsoak pistons.

Ultra-rigid 3D design machined from a choice of billet HE15 or HE30 in hard anodised finish.

## ROAD CALIPERS

Our extensive range of road calipers feature dust seals and internal fluid transfers. Machined from Billet HE30.

Available in a range of colours and options to suit your needs.

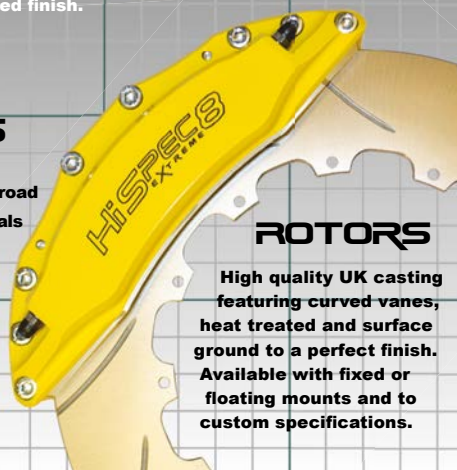

## ROTORS

High quality UK casting featuring curved vanes, heat treated and surface ground to a perfect finish. Available with fixed or floating mounts and to custom specifications.

motorsports quality  
ROD ENDS, SPHERICAL BEARINGS  
and MS spec. UNIVERSAL JOINTS



AURORA®  
RODOBAL®

inch  
metric

BELDEN®  
universal  
Seals-it®

most extensive stock in Europe, US / EU parts  
basic / regular / top product lines,  
flexible service, worldwide delivery  
support service to OEMs and national distributors

ROD ENDS ACCESSORIES:  
side seals, protection boots,  
jam-nuts, right-hand and left-hand  
grooved bearings staking tools

Getecno Ltd. - ITALY

fax +39 010 835.66.55

e-mail: info@getecno.com

contacts in English, Deutsch, Français, Italiano



Motorsport Essentials



Gauge Fittings



Oil, Fuel & Water Hoses



Silicone 3 PLY & 4 PLY & Vacuum Hoses



Linkage Parts & Suspension Rod Ends



Brake & Clutch Hoses, Spares & Fittings



Hose Clips, Joiners & Fittings



Fan Thermostat Switch Kits



Electrical Accessories



Suppliers of Race, Fast Road, Classic & Commercial Products

Tel: 01933 778335

www.LMAautoparts.co.uk

Fax: 01933 778341

sales@LMAautoparts.co.uk

## DOCKING engineering Advanced Cooling Systems

Water Radiators  
Intercoolers  
Oil Coolers  
Heat Exchangers  
System Design  
Ancillary Products

Manufactured to your requirements  
by the UK's leading supplier.

Email info@dockingengineering.com  
Tel +44 (0) 1327 857164  
Fax +44 (0) 1327 858011  
Web www.dockingengineering.com



Certified to CAA & AWS  
Welding Standards

Unit 15 Silverstone Circuit  
Silverstone, Northants  
NN12 8TL, United Kingdom

# Differential equations

Our resident maths guru crunches the numbers on an often neglected, yet hugely important, aspect of racecar set-up – the diff

By **DANNY NOWLAN**

One of the most important, yet often overlooked, set-up items in engineering a racecar is the differential. The reason the diff is so important is that it plays a critical role in both the power delivery and the car handling. The goal of this article is to outline the problem the differential poses, and then to show you how to use simulation tools to solve this.

The principal problem we have with the differential is that we have two wheels moving at two different speeds. This problem is illustrated in **Figure 1**. The reason why tuning the diff is such a problem is that for a given forward speed,  $V$ , and a given yaw rate,  $r$ , because the wheels are separated by a track,  $t$ , we have the inside wheel velocity at  $V - t.r/2$  and the outside wheel velocity is at  $V + t.r/2$ . As we will see as we continue our discussion, this is the root cause of why 'diff' might also be short for difficult.

What makes a tricky situation worse is the fact that the differential was never truly engineered. The differential sort of just happened. Because of this, there are many different types of diffs.

The first type of differential you have to deal with is the open diff. The open diff has a bevel gear arrangement that allows the inside and outside wheel to spin freely. It also distributes the

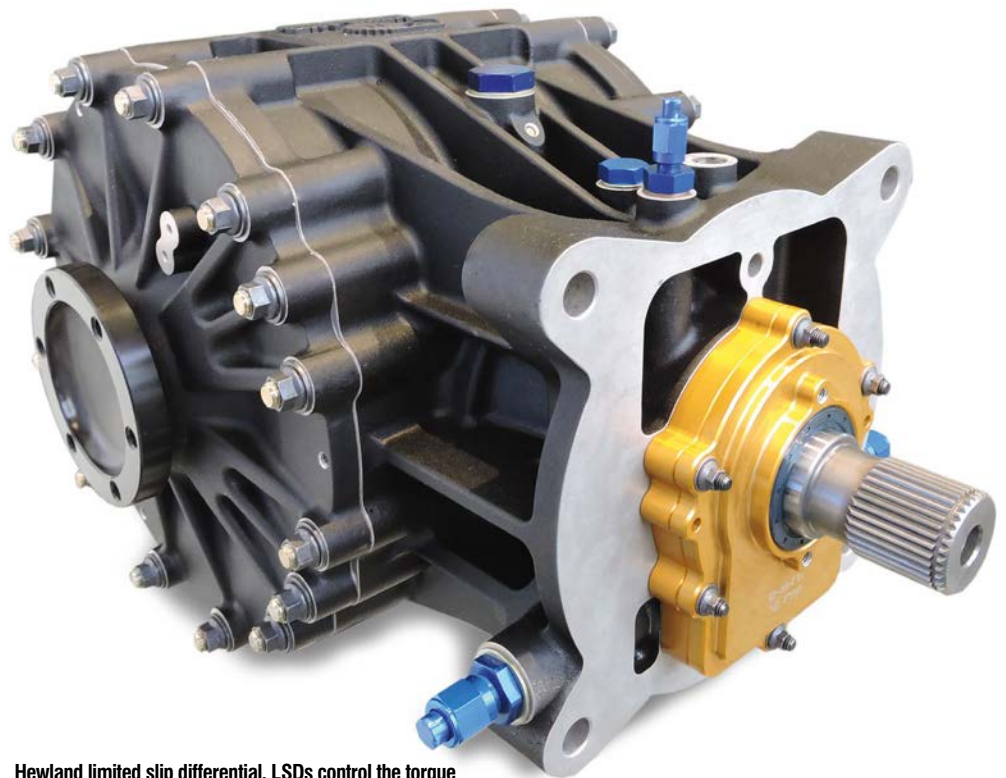

Hewland limited slip differential. LSDs control the torque distribution using ramps and clutch plates and are ideal for motorsport

**Figure 1: The differential problem**

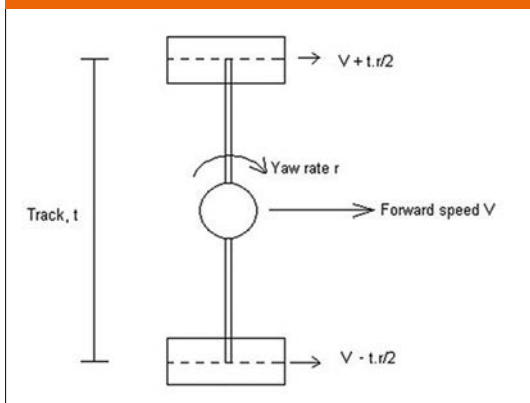

**An open diff has this nasty habit of transferring all the power to the wheel that spins the most**

**Figure 2: Limited slip differential (courtesy of Hewland Engineering)**

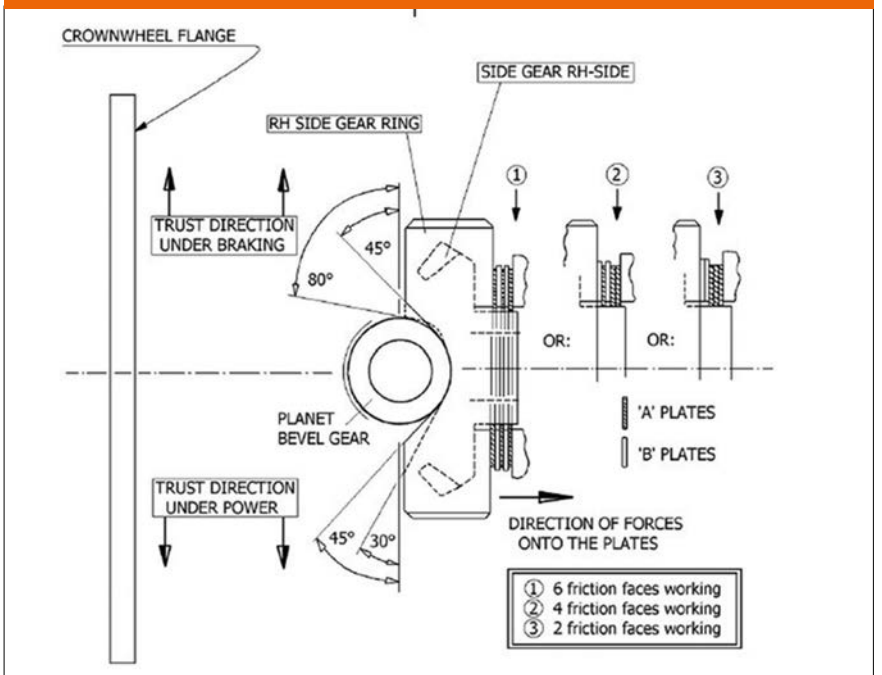



forces equally. That's okay for low power road use but very quickly runs out of steam for racing. The open diff has this nasty habit of transferring all the power to the wheel that spins the most.

Then there is the locked diff, which connects the wheels together via a fixed shaft. This ensures the rotational speed of the two driven wheels is identical. For a tractor and for off-road applications it certainly has its uses. Also, for high-powered applications it does present some advantages, but as we shall soon see, this is like cracking an egg with a sledgehammer.

## Limited slip

For most racing applications the most common differential you will deal with is the limited slip differential (LSD). This is illustrated in **Figure 2**.

The LSD is effectively an open diff with ramps and clutch plates to control the torque distribution under acceleration and braking. The viscous limited slip diff is another type of LSD, which uses fluid as opposed to ramps, making the torque distribution more continuous.

We should also mention the other types of differentials. The Torsen differential is a torque sensing diff that will distribute the forces based on differential torque. However, because it consists of gears it can be fiddly to tune.

Then there is, of course, the electronic differential, where you can use electronically actuated clutch packs to tune what you want. This is the ultimate evolution of the differential and offers some very elegant solutions to what is a very messy problem. Unfortunately, since most motorsport regulatory bodies have

# For racing applications the most common diff you will deal with is the limited slip differential

**Figure 3: Differential dyno**

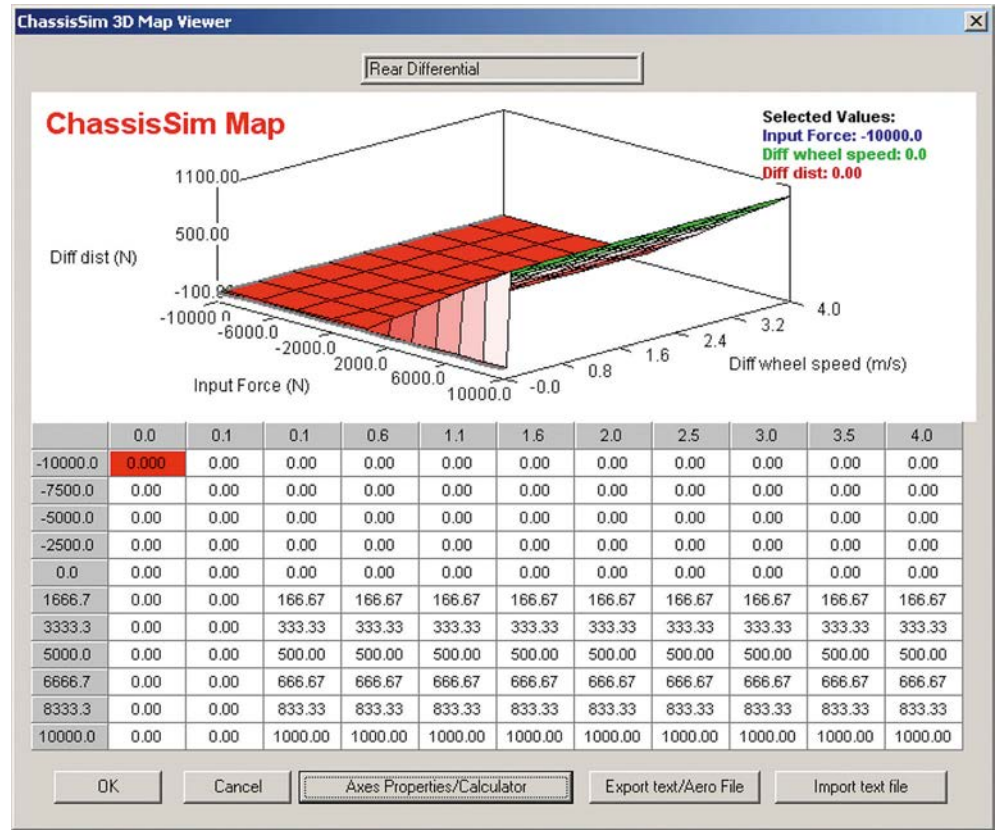

## EQUATIONS

### EQUATION 1

$$LR = 100 \cdot \frac{T_{SLOW} - T_{FAST}}{T_{TOTAL}}$$

#### Where:

- LR = locking ratio
- $T_{SLOW}$  = torque on the slower wheel
- $T_{FAST}$  = torque on the faster wheel
- $T_{TOTAL}$  = total torque

### EQUATION 2

$$V_{Diff} = t \cdot r \approx \frac{t \cdot a_y}{V}$$

$$SR_{MAX} = \frac{V + t \cdot r / 2}{V - t \cdot r / 2} - 1$$

#### Where

- $V_{Diff}$  = the differential speed between the wheels
- $SR_{MAX}$  = the maximum slip ratio
- V = current forward speed of the car (m/s)
- r = current yaw rate (rad/s)
- t = relevant track width.
- $a_y$  = lateral acceleration (m/s<sup>2</sup>)

### EQUATION 3

$$F_{yOUT} = wd \cdot m_t \cdot a_y \cdot \frac{Fm_{OUT}}{Fm_{IN} + Fm_{OUT}}$$

$$F_{yIN} = wd \cdot m_t \cdot a_y \cdot \frac{Fm_{IN}}{Fm_{IN} + Fm_{OUT}}$$

$$F_{xOUT} = \sqrt{Fm_{OUT}^2 - F_{yOUT}^2}$$

$$F_{xIN} = \sqrt{Fm_{IN}^2 - F_{yIN}^2}$$

$$CR = \frac{F_{xOUT}}{F_{xOUT} + F_{xIN}} - 0.5$$

#### Where:

- $a_y$  = lateral acceleration (m/s<sup>2</sup>)
- wd = relevant weight distribution
- $m_t$  = total mass of the vehicle
- $Fm_{IN}$  = max possible tyre force for the inside tyre
- $F_{xIN}$  = longitudinal tyre force for the inside tyre
- $Fm_{OUT}$  = maximum possible tyre force for the outside tyre
- $F_{yOUT}$  = outside lateral tyre force
- $F_{xOUT}$  = longitudinal tyre force for the inside tyre.
- CR = critical locking ratio

technophobia as their default setting these differentials are banned in most categories.

Now that we have a feel for the differential problem and the types of differentials out there it's time to address the problem. At its most fundamental level the differential transfer forces from the wheel that is spinning the most to the wheel that is spinning the least. This can be quantified by **Figure 3**. The two horizontal axis are input force, which is the force coming from the engine, and differential wheel speed. The z axis is the differential force that is applied to each wheel. Here then, for an input force of 10,000N and at a differential wheel speed of 4m/s the delta is 1000N, thus the force differential is 10,000/2 - 1000N for the wheel that is spinning the most and 10,000/2 + 1000N to the wheel spinning the least. This can also be shown with torque, but bottom line it means the same thing.

## Locking ratio

The other metric to describe diff performance is locking ratio. The locking ratio is often quoted by diff manufacturers as a metric to describe diff performance. It is presented mathematically in **Equation 1**. It's a really good metric to have under your belt and it readily describes what you can see in **Figure 3**. Also, if you have a tyre model we can quickly establish some

Figure 4: Illustration of the critical locking ratio

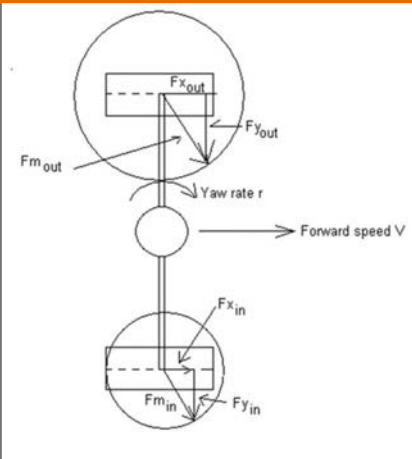

Figure 5: Super diff plot for a Formula 3 car

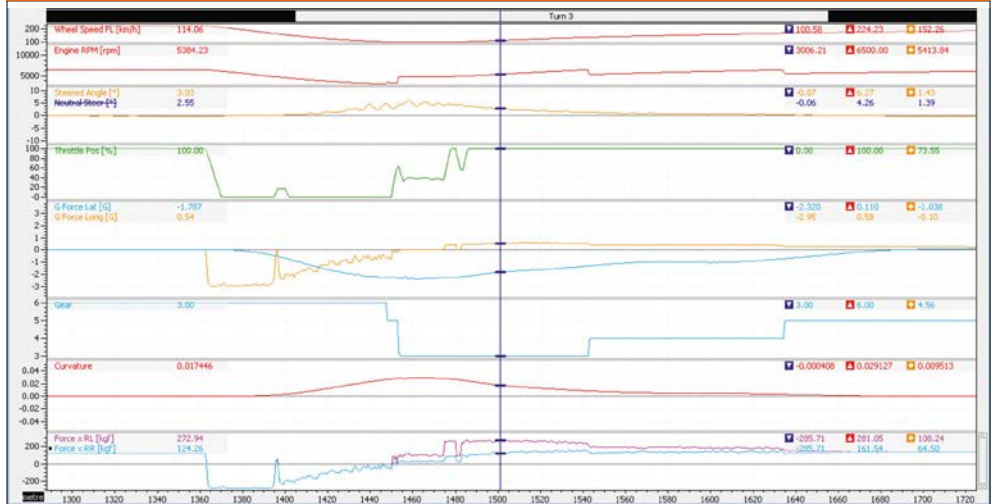
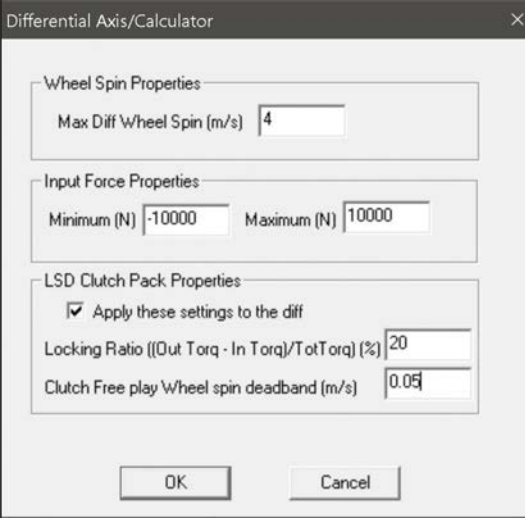

Figure 6: Differential tuning settings



very handy metrics on which to classify where you need to go with the diff; which is shown in **Equation 2**. If you know your tyre model you can quickly determine good rules of thumb with the locking ratio. This is summarised in **Equation 3**. The locking ratio is double the critical ratio. But the important thing in all this is that it gives you the intellectual framework to approach this problem. This is illustrated in **Figure 4**.

### Super diff

While all this might seem terribly daunting there is help at hand with ChassisSim, which returns some key logged channels. In particular in the channels *Force Fx FL -> Force Fx RR* there are the longitudinal forces. The other thing it offers is its super diff setting. The super diff setting will distribute the forces in the ratio of the ideal longitudinal forces. When you combine this with

the *Force Fx FL->RR* channels ChassisSim will now tell you the ideal locking ratio you should be running the diff at. This analysis is illustrated in **Figure 5**. The plot to pay attention to is the bottom one, which shows the rear longitudinal forces. All you need to do is cross reference that with **Equation 1** and this will tell you what the ideal locking ratio under power is. Also, if you want to get really clever, ChassisSim returns the logged speeds and engine torque. If you create a few math channels you wind up with something like **Figure 3**. I believe this is a very powerful tool.

What you then do is toggle to the limited slip diff option and start playing with the locking ratio. In particular in ChassisSim you'll be using the settings shown in **Figure 6**. The major thing you'll play with is the locking ratio under power. This is the critical element to use when tuning the diff, and it gives you a start point.

You then apply these settings and look at the results. An example of this is presented in **Figure 7**. Clearly, these distributions aren't as extreme as the super diff, since this diff just had static settings, but you get the idea.

However, there are some traps for inexperienced players and it would be wrong not to acknowledge them. Firstly, to use this properly you need to have a good handle on your slip ratios for the tyres. A ballpark number is about 10 per cent, but this will vary. The second thing to be aware of is that the ideal distribution of forces will add a turning moment to the car and this can be quite significant. It is a limit you have to approach very carefully, depending on the skill level of the driver you are dealing with.

In closing, while the differential poses a significant challenge, fortunately it's by no means insurmountable. The difficulty with the diff comes due to the differential wheel speed of the inside and outside tyre, and the fact the diff sort of just happened. But there are metrics that can greatly aid in our understanding of the diff and simulation packages like ChassisSim can light the way. So if you want to make a difference with the differential, this is the way to go. 

Figure 7: LSD longitudinal forces plot



It is a limit you have to approach very carefully, depending on the skill level of the driver you are dealing with

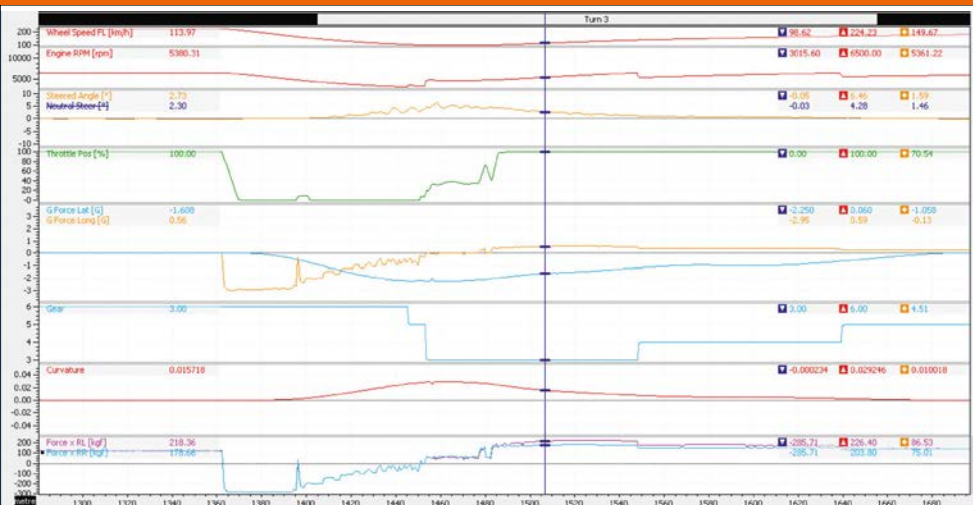

Automotive engineering from design to production



## Power into motion...

...developing and manufacturing performance driveline components for OEMs. Our ATB Differential is the ideal mechanical traction solution for tomorrow's high torque EV and ICE applications.



VESTRY ROAD, OTFORD, SEVENOAKS, KENT TN14 5EL

T: 01732741144 F: 01732741555 E: info@quaife.co.uk W: www.quaife.co.uk

FOLLOW US ON



@quaifeengineering



@QuaifeEng



# Cloud base

How McLaren is making the most of cloud computing technology to call the strategies before, during and even after a grand prix

By NICK BAILEY



**‘We can share valuable content such as video footage in real-time, which enables us to make better strategy calls’**

## Sharing data

**B**eing able to process the data is all well and good, but sharing it quickly and securely is equally critical. In the past McLaren relied on an MPLS connection to send real-time video back to Woking. However, the system was expensive and didn't have the bandwidth for the 11.8 billion data points being sent per year. This caused video lag and image quality issues, hindering the team's ability to monitor each race and accurately assess each situation.

NTT Communications suggested that the team used software-defined wide-area network, (SD-WAN), which is quick and reliable data and is more affordable. Such is the change in volume and the reliance on data to power essential team communications and machine learning that the NTT SD-WAN service is now considered a key race tool.

Operating via a simple and more cost-efficient broadband internet service, the team in Woking can now synchronise race data with high quality live video feeds. 'With this solution, we estimate that we can shave seven to eight seconds from video delay between track and Woking,' says Singh. 'That means that our vast team of experts in Mission Control can be involved in all decision making.'

Using SD-WAN at Silverstone this year McLaren's ability to make a quick decision and pit both drivers under the second safety car enabled a change of tyres that gave the team a good chance of gaining track position. 'Our result at Silverstone perfectly demonstrates how technology that enables us to make smart decisions can result in tangible race benefits,' says Fernando Alonso.



**Fernando Alonso says the SD-WAN technology McLaren employs has made a real difference and has helped the team gain places on track; at Silverstone this year it played a part in a well-timed pit stop call**

**W**ith ever increasing technical restrictions, gains in F1 are usually marginal. Hundredths of seconds shaved off a pit stop or thousandths of a second with a new wing all add up. So, given that race strategy can play a critical role in the outcome of a race, it's unsurprising that innovation in this area is booming. What *is* surprising is that some of the gains possible are up to 25 per cent.

The need to make quick decisions is well understood by race engineers. It's not unusual to make a call in less than five seconds; responding to a rival's strategy, a safety car or change in the weather. At McLaren, those

decisions ultimately fall to Randeep Singh, who is head of race strategy at McLaren Racing. The rise in data has offered Singh and his team significantly more information from which strategies can be developed, but determining and analysing what data is relevant at a certain point in time is a huge challenge.

McLaren's 2018 car is equipped with more than 400 sensors; there are 200 on the battery alone. Interpreting the myriad of data streams correctly, identifying trends, coupled with understanding how the race is playing out for each competitor, can minimise incorrect strategy calls that could be the difference between finishing in the points or not.

To make decisions with confidence, Singh relies on analysing simulations of multiple scenarios of how the race will play out. The volume of possible simulations is astounding; it's not millions but billions of billions. 'We have more strategy permutations than there are electrons in the universe,' suggests Singh.

## Tech support

To run this level of data reliably from each of the 21 tracks F1 visits, McLaren has turned to NTT Communications to provide the answers. The Japanese firm has been a technical partner to the team since 2016, supporting McLaren's IT strategy, and has developed a number





McLaren's trackside team is supported by a further 32 engineers at its Mission Control facility in Woking

of bespoke solutions for it from its range of products that are normally found in industries as diverse as software, chemical production and even airlines. McLaren marks one of the first forays into motorsport for the company.

## Cloud and clear

To assist Singh and his engineers in running the multiple simulations deemed necessary, NTT Communications developed a version of its Enterprise Cloud product. According to NTT, the Enterprise Cloud is providing processing power equivalent to 1000 machines, enabling McLaren's advanced machine learning software, MORSE, to process 25 per cent more simulations in the same amount of time.

Singh will typically start developing the simulations for a grand prix some three months ahead of the race. 'This is when we nominate tyres for a particular race,' he says. 'We then include our data from previous races, that now stretches back for more than 20 years, along with figures from the current car and our rivals. In the cloud, our MORSE simulation software then starts processing the simulations and that continues after the grand prix has finished. Reviewing a race or qualifying session is just as vital for the machine learning.'

According to Singh, just 10 years ago about 100MB of data would be produced by McLaren over a race weekend. In 2018 that has now reached one terabyte. To analyse

## Reviewing a race or qualifying session is just as vital for the machine learning

## Saturday night fever

Once qualifying is over, the McLaren engineers and strategists have been using their Saturday nights to run simulations of the grand prix that's coming up the next day. 'Everyone takes a role. They could be a strategist for us or they could play the role of another team strategist or driver. We then run a grand prix, using the Enterprise Cloud at up to eight times the speed of the race,' explains Singh. 'These sessions help us to prepare for any eventuality and they come up with challenging scenarios.'

Unpredictability is the key to making these simulations effective. 'Maybe I will call a safety car when the workload is already high and see how it plays out. It is one way for us as strategists to get race-fit,' Singh says.

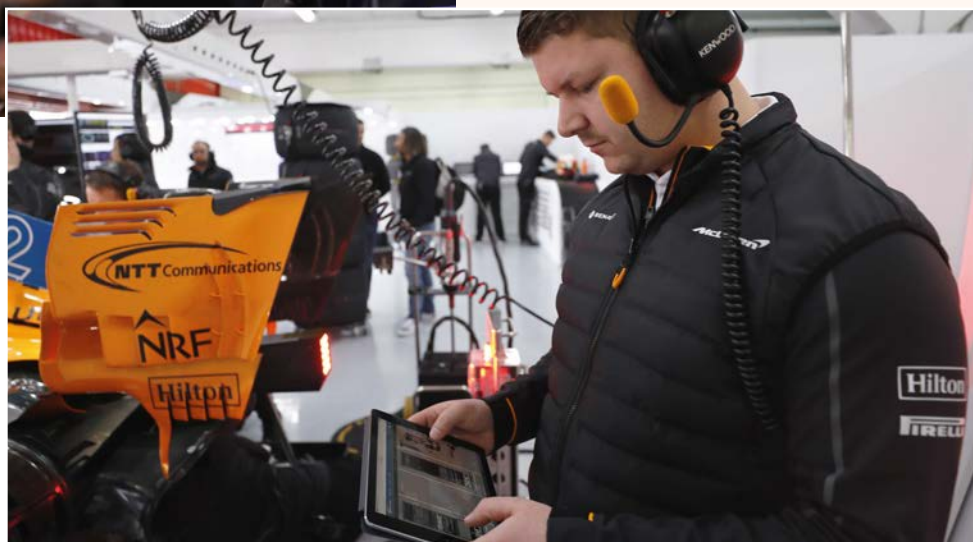

Data drives Formula 1 and the McLaren MCL33 is equipped with more than 400 sensors. Sorting through the huge amount of data now generated to formulate effective race strategies is one of the great challenges of modern day grand prix racing

## McLaren will typically start developing the simulations for a grand prix some three months ahead of the race

or process and act upon this data, McLaren's trackside engineers are supported by a team of 32 engineers at Mission Control within the McLaren Technology Centre (MTC) in Woking in the UK. 'Regulations restrict the number of engineers we can have working at the race track, so we have to share data with the team back at our base,' says Singh. 'Relying on NTT Communications network, we can share valuable content such as video footage in real-time, enabling us to make better calls.'

## Belt and braces

While some Formula 1 teams have invested in having all their processing power in-house, Singh believes teams can mitigate risks by using the cloud. 'We have our own in-house processors but if we have a fire alarm, they have to be shut down, causing downtime and disruption. This very thing hit us during the

Australian Grand Prix in 2017 and that was painful. Now, with the Enterprise Cloud we can keep on working with added confidence.'

The ability to use the cloud at any time, and its scalability, means that it could easily be adopted by teams in other categories as a more affordable and flexible way to determine their race strategies. Sportscar racing, such as in the WEC, is an obvious candidate.

Even if a car isn't capable of winning a particular race it's clear that race strategy can play a part in getting a better result, something that the drivers have come to appreciate. 'What we see and feel on track is important, but simulation data is critical for our continually developing race strategy, even mid-race,' says Fernando Alonso. 'Time and again, we have used this to our advantage and scored a better result than we could have expected. It's been a critical part of our approach.'

info@ttvracing.com



**TTV**Racing

Flywheels &  
Special Clutches



Designed & Manufactured in the UK  
**What can we make for you?**



# Presidential address

**With the 2021 F1 regs rumour mill spinning faster than the crankshafts at Monza, FIA president Jean Todt took the opportunity to provide some hard facts – while also waxing lyrical on budget caps, Halo and even motorsport at the Olympics. *Racecar* took a front row pew**

By **SAM COLLINS**



**D**uring the Italian Grand Prix at Monza, FIA president Jean Todt took time to address the media with what might best be described as a 'state of the nation' discussion, covering a number of motorsport categories, but with the future of F1 as his main focus.

One of the reasons for this is that there has been much discussion about the future of the championship, with a completely new rulebook scheduled for introduction in 2021. However, the announcement of these new rules has been delayed repeatedly as agreement over the details of the new power units in particular has been hard to reach. Todt, who was re-elected for his third term as president last year (unopposed), said of this: 'For months there have been lengthy discussions on





the engines, but there has been some delay with that because we don't want to only speak about the technical regulations, we also want to present the sporting and commercial elements of 2021 too. At the first meeting we spoke to decide on what the regulations should be from 2021. We wanted, as a vision for the future, the drivers being able to compete without having to think about lift and coast or fuel saving. We wanted to increase the fuel flow too. What we didn't want to hear was anyone saying they had to compromise the way they use the engines because of the technical regulations.

'All of those parameters were agreed unanimously, and we wanted to announce the new engine regulations by the end of July,' Todt added. 'We are very close to concluding the exercise, but I do confess we are a bit late with it now, but it will be finalised and announced soon and it will not be a continuity of the current regulations.'

## Engine timing

A number of figures in Formula 1, not least some associated with the manufacturers, have stated that they would like to see the current regulations continue as they see no reason to change, and with the rules still not finalised time is running out for the manufacturers to start work on the new power units.

Ross Brawn, F1's managing director of motorsports recently stated that he felt that the regulations could be delayed beyond 2021: 'We want to try and create a set of technical regulations on the engine, which are appealing to new manufacturers coming in, as well as consolidate our existing engine suppliers,' he said. 'I think we just need to think of our timing on that, whether



Todt says Formula E (its new car pictured) is a huge success but he does not believe F1 will ever be all-electric



2021 is the right time to do that, or whether it's better to keep that powder dry until we can be certain that a major regulation change will bring fresh blood into the sport. My feeling is that there's still quite a lot we can do on the engine side in terms of sporting regulations such as limits on dyno test time, number of upgrades during a season, consistency of specification to all customer teams etc. On the engine, we need to decide if now is the time to have a revolution or an evolution.'

## Tension at the top?

However, in his discussion at Monza Todt seemed to reject any suggestion of the regulations being delayed and that the choice not to have a regulatory revolution had already been made, hinting at a difference of opinion between the FIA's technical department and that of Formula 1's technical team. Brawn however has also suggested that a delay could help attract new manufacturers to the sport. 'What I'm mostly concerned about is the capacity for a new supplier to come in,' Brawn said. 'We have four great manufacturers in Formula 1 and we don't want to lose them. But equally, we don't want a situation where the technical regulations make the challenge of developing a Formula 1 engine so great that only if you've been doing it for seven years can you hope to compete. A reset in the technical regulations provides an opportunity for someone who is new and has the opportunity to perhaps at least start in a better place, instead of trying to compete with someone who has been pursuing these objectives for a long time.'

Yet despite these comments from Brawn, Todt made it very clear that he doubts any new manufacturer will join the series in the near future, and he also said that he is not at all focused on attracting new manufacturers after a plan for LMP1 and Formula 1 to have common engine regulations failed. 'With

**'It would be wrong to change all the regulations just because one or two manufacturers might be coming in'**

Todt says that 2021 will not see a revolution in the engine regulations, which will be good news to current suppliers such as Honda. Its 2018 power unit is seen here in the Toro Rosso



**The first corner crash at the Belgian Grand Prix, which saw Fernando Alonso's McLaren ride over the top of Charles Leclerc's Sauber, silenced many critics of the Halo device**

Formula 1 having its own standalone rules I was very sceptical about new manufacturers coming in,' he said. 'That is why I wanted common engine regulations with other championships, because it will probably encourage more manufacturers if you can have seven to ten customers able to buy that powertrain. But that has not happened. I was always pessimistic about new companies coming in when the situation in Formula 1 is as it is now with specific technical regulations, I did not think you could have more than four manufacturers.'

'Personally I think it is an achievement to have four different powertrains for 10 teams, its 2.5 per team,' Todt added. 'My priority is to keep the four we have. It would be very unfair to the four involved to change everything just to attract a new manufacturer. What about all the investment they have made? It would be wrong to change the regulations just because one or two might be coming in. That is why it won't be a revolution on the engine in terms of the new rules. If we can secure the four we have it will be a great achievement.'

### **Porsche rumours**

Rumours still abound that Porsche was or is working on a Formula 1 powertrain or even a complete works team. When questioned about this Todt declined to discuss specific brands but did admit it was possible that at least one manufacturer wanted to join the series at one point. 'There was serious demonstration of interest from one manufacturer who said to us "we are not in a position to commit for 2021, but it is very important for us to know exactly what the regulations will be", because they could have very strong interest in future,' he said.

With the automotive industry increasingly moving to widespread electrification there have been suggestions, not least from Bernie Ecclestone, that Formula 1 will go all-electric in future in another attempt to attract manufacturers to the sport, but Todt rubbishes this suggestion. 'It would be a nonsense to



**A new version of the controversial Halo is now under development and it may well be seen in F1 in 2021**

say that in the future F1 will be electric. It's not going to happen; simply you could not do it,' Todt says. 'We have implemented FE, and it is true that there is an exclusive agreement in place for a number of years with the promoter, but we are talking about two different categories. Formula E does not have the performance of F1, and one of the reasons Formula E is run only in cities is that there would be absolutely no interest in it if it was run on circuits like Monza. You cannot compare the two.'

Despite this Todt is proud of FE. 'It is the baby of the FIA family, it is growing well,' he said. 'When it started you needed two cars to do the race, but the first race for the new car, in Saudi Arabia, you will only need one car to do the race. It shows how motor racing is not only a show but also a laboratory.'

One other feature of Formula E which Todt is proud of also appears in Formula 1, namely the Halo. When it was first introduced it received a very negative reception from fans and

**'It's nonsense to say that in the future F1 will be electric. It's not going to happen'**



# **AUTOSPORT** INTERNATIONAL



**THE RACING CAR SHOW**

**NEC, BIRMINGHAM, UK**

**10-13 JANUARY 2019**

10-11 STRICTLY TRADE-ONLY DAYS

**REGISTER NOW**  
[AUTOSPORTINTERNATIONAL.COM](http://AUTOSPORTINTERNATIONAL.COM)

AUTOSPORT  
INTERNATIONAL  
IS PART OF:

**motorsport**  
NETWORK

INCORPORATING

**PERFORMANCE & TUNING  
CAR SHOW**

**AUTOSPORT**  
INTERNATIONAL  
**ENGINEERING  
SHOW**

# ‘I was a bit surprised to see all the negative comments about Halo’

the media, but following two major accidents opinion seems to have changed. The first of these rather big crashes came in a Formula 2 race in Barcelona, and the second at the start of the Belgian Grand Prix. In both incidents a car hit the Halo of another. ‘For myself I have no problem with the way it looks and I was a bit surprised to see all the negative comments,’ Todt said. ‘There was a lot of controversy about its introduction into F1, but when it was introduced to other categories I did not see a single line of criticism written. This project was started because some crashes we saw were just not sustainable. We asked our technical people and safety people to come up with the solution and Halo was the best solution. At a certain time it was such an emotive issue that the drivers twice wrote to me to urge me to do something [about] head protection. They wrote to Bernie Ecclestone, Charlie [Whiting] and myself to say that they wanted something done. We did a lot of testing and simulations and it is clearly an improvement on safety.’

‘What has happened since, not just the [Charles] Leclerc crash at Spa but also the one with the F2 driver, proved it was the right thing to do,’ Todt added. ‘We will implement it in F4 in 2024. Clearly we are convinced that it was the right decision. Saying that, motorsport remains a dangerous sport.’

## Halo effect

Safety, both on track and on the road, remains a major area of focus for Todt and he sees the 2021 regs as an opportunity to improve this further and a new version of the Halo is under development, called ‘Halo 4,’ likely to be a part of the new regulations. ‘Forty years ago you were losing someone on track every time, it was normal. Now it is not normal and maybe you could put racing at risk if we had too many crashes with consequences,’ Todt said. ‘It could be a real question of [racing continuing]. We need to take it into consideration when we talk about new regulations, cost caps and governance. We may have to report to international organisations about what we decide, so I think it is a good opportunity to improve things further.’

It is widely believed that a cost cap will be introduced in 2021 as part of a number of measures to reduce the F1 teams’ annual expenditure and Todt confirms that it is under consideration, though did not give details of exactly what the cap would be or how it might work. ‘We have never really spoken about budget caps on the engine but in terms of the whole team expenditure we are quite advanced on discussing budget caps, but excluding the engine,’ he said.

One factor which will have a key impact on the annual budget of the teams is the number of races. With 21 on the

calendar currently, some teams are already at the point of having to rotate staff, yet F1 owner Liberty Media has suggested that more races may be added to the schedule with Vietnam and Las Vegas the latest locations rumoured to be in negotiations for the right to hold a grand prix. ‘The number of races is really something for the commercial rights holder,’ Todt said. ‘Once they present a calendar, the WMSC has to support it, or object to it. I think 21 is good but 20, 23 races, I would have no problem. The commercial rights holder is doing all it can to bring Formula 1 up to date, bring it into modern times. We are very supportive of what they are doing.’

## Holding the ladder

Of course, Formula 1 is not the only concern on the FIA president’s mind and he is working to rationalise the sport and create a ladder of progression in all categories, though this is far from a new project. ‘The single seater pyramid is almost complete, with F1, F2 and F3 all with the same promoter, making things clearer and simpler,’ Todt said, referring to Formula 3’s merger with GP3 next year in the latter case. ‘F4 we have had now for a while. In terms of other series we are still working to develop WRC and we want an effective rally pyramid, down to regional rallying. I visited Rwanda recently to discuss the African Rally Championship, including getting Africa back on the WRC calendar and I think that will happen. We are also working on the WEC where we want to introduce a new category to replace LMP1, which will sit above LMP2 and GT. We think that has great potential, and we are also working on touring cars, which at the moment is a Cup with WTCR.’

Another move that Todt is also looking to make is one which has been discussed for decades but without any real progress, and that is introducing motor racing into the Olympics. In October 2018 this will take a major step forward.

‘We will be in Buenos Aires for the Youth Olympics with electric karting, and we are working closely with the IOC [International Olympic Committee] to make it an Olympic category,’ Todt said. ‘It’s a kind of education programme for youths too, and it is creating quite a lot of interest. We will make the conclusions after the event but we have a lot of expectations about it, not just us but the whole Olympic community.’

Some sort of motorsport in the Olympics might be something to look forward to, then. But whether Todt can look forward to another term as president of the FIA might rest upon his ability to introduce a new rulebook into Formula 1 in 2021; with another presidential election due in 2022 this could be crucial for his re-election campaign. 

GP3 is to become an all-new spec Formula 3 championship next year



# ADVANCED ENGINEERING 2018

31 Oct & 1 Nov 2018, NEC, Birmingham



## The UK's largest annual gathering of OEMs and engineering supply chain professionals



**AERO  
ENGINEERING**



**COMPOSITES  
ENGINEERING**



**AUTOMOTIVE  
ENGINEERING**



**PERFORMANCE METALS  
ENGINEERING**



**CONNECTED  
MANUFACTURING**



**NUCLEAR  
ENGINEERING**

NEW FOR 2018

**REGISTER  
FOR FREE  
TODAY**

Register your interest to visit the UK's largest  
engineering event, giving you access to:

- ✓ **600+** exhibiting suppliers and partners
- ✓ **200+** Continuing Professional Development certified presentations and case studies from OEMs, industry experts and government
- ✓ **Innovative** and exciting feature exhibits showing the latest technologies in action
- ✓ **Enabling Innovation zone** for SMEs and start-ups to present new inventions and ideas

Register your interest to attend at:

[www.advancedengineeringuk.com](http://www.advancedengineeringuk.com)

#AEUK18

by EASYFAIRS

Interview – Mark Gemmell

# Potential energy

**With Formula E now oversubscribed could the embryonic Electric GT series be in line to benefit? We spoke to the man behind it to check on its progress**

By **MIKE BRESLIN**



**‘The car was tested recently and it performed very well over a full race distance of around 70 kilometres’**

**E**lectric motorsport has arrived. There's little doubt of that, certainly where the manufacturers are concerned, at least. Just take a look at the list of car makers now involved in Formula E. In fact, Formula E is pretty much full now, and with this in mind where's a motorsport operation looking at getting plugged in to this brave new world of electric racers to turn?

There is the spec Jaguar I-Pace E Trophy that's set to support FE, but maybe a more attractive option is Electric GT, an initiative which offers racing on proper circuits and, long term at least, will be an open category. Problem is, Electric GT has gone a bit flat recently, and the first event of its Electric Production Car Series (EPCS) – which was due to take place in November – has now been pushed back until 2019. The reason? Money. 'Basically we're in a situation where we've got everything together, but now we need to close all the finances for the championship,' says Mark Gemmell, the man behind the Electric GT initiative. 'So that's the final ingredient we're looking at now, talking to investors and getting that deal so we can get going.'

## Seal of approval

There are certainly aspects of Electric GT that might interest an investor, not least the fact that this series had been approved by the FIA. 'When we first went to see the FIA two and half years ago it felt like that was a huge hurdle to get over,' Gemmell says. 'Even a year ago it felt like it was insurmountable, so it was definitely a major achievement to get that done. But I think that with any venture when you get one thing done then you pretty quickly forget it and face the next one.'

But Gemmell insists the car itself, the base model is a Tesla P100DL, is certainly not his next worry. 'We are very happy with where the car development is,' he says. 'We did a longer test recently and it performed very well over a full race distance, around 70km. I don't really think there were ever any doubts that it would be able to do that, and in fact the car finished with 25 per cent of power left, so we know it can do more, but we only need a 35 minute race distance.'

The car weighs in at 1780kg and boasts 585kW and 995Nm of torque, but while the first EPCS will be for Teslas the series is not strictly a spec series and the long term goal is to attract other OEMs. 'I think Formula E started off with professional teams and then the manufacturers moved in, and we expect something similar to happen [so far one team has signed up, SPV]. But manufacturers are in a tricky situation, as they don't actually have much in the way of [electric] production cars. Formula E is okay because they don't actually have to have a car. But in our case we do want to see vehicles that have some sort of meaning to the production equivalent. At the moment there are not too many OEMs that are producing cars at the quality of Tesla. So, the day they do, we expect this form of racing will be ideal for them, and we are certainly heading in that direction.'

As things stand any OEM wishing to join the series in its first season will have to fit the Tesla template. 'If you're an OEM you

have to be able to meet a minimum power to weight ratio of 0.3bhp/kg, and essentially be able to create 78kW of energy to be available for a race stage; and the vehicle needs to be more or less the same size as the Tesla. It's not a pure Tesla race series, it's just that at the moment that is the only car that can perform on a circuit, but if an OEM can produce a car that fits those parameters then they are very welcome.'

## Super charged

In the recently announced five-year technical road map it says years four and five will see GT/LMP style bodywork, but Gemmell clarifies this and says it will be more like a GT version of DTM – similar to Super GT, perhaps.

That road map is actually quite an ambitious document. Headline numbers for season four and five include a lighter car (around 1500kg); battery capacity of 140kWh; motor power of 825kW (1122bhp) and a top speed of 380km/h (236mph).

If all this should come to pass (the road map is under review, we're told) then this could clearly be a high level championship, and the estimated budgets reflect that. 'We think that for a two car team you're probably spending about €1.1m, and maybe with all the expenses it might be 1.5,' Gemmell says.

But for that teams will get to race at some top class venues – with Nurburgring, Paul Ricard and Silverstone on its initial calendar – for one of the things that differentiates Electric GT from Formula E is that while the latter is, as part of its DNA,



wedded to the idea of street racing, Electric GT is most certainly not. 'The circuit owners put a lot of effort into preparing their circuits; the safety is important, as is access to the public,' Gemmell says. 'It's not an easy thing in a city; if you plopped 10,000 extra people on a few city streets you'll notice the jams. It's difficult to hold an event of the right magnitude in a city centre.'

Of course, part of the reason Formula E races on city streets is simply because it can. There is not much in the way of noise issues when there's not much in the way of noise. But little noise on a big, open, international circuit such as Paul Ricard with acres of runoff between the cars and the paying spectators; might that not be a little underwhelming?

'The lack of noise is a feature, a benefit, that we want to use to our advantage,' Gemmell says. 'One of the things that you won't hear in motorsport normally is any noise from the drivers. You might hear the pit radio, but it's pretty challenging to understand that because of the noise in the car. But in our case because the noise is low the sound is high quality so you can hear the drivers very well, and we plan to use that.' As well as this pumped audio, tyre supplier Pirelli has also told the series it could engineer noise, like squeal, into its tyres.

## Sunny side up

While they might be hearing the drivers, and perhaps tortured rubber, what the fans will be seeing is three races, which means recharging in between (there will be supporting e-karting and esports series events between the Electric GT races). And this throws up one fascinating possibility. 'One of our potential partners would employ solar arrays at the circuit, which could form part of the shade structure, and then we can get enough power to charge batteries,' Gemmell says. 'Over a couple of days prior to the race those batteries would be filled, and then they will be ready to charge the cars as needed. It wasn't feasible when we started to think about the championship, it was very much a blue sky idea, but now it's thoroughly doable, and this shows how quickly technology is progressing.'

How Electric GT progresses depends very much on whether it can find an investor which will buy into its vision, which is a very different vision from Formula E. But with the latter now a closed shop for new manufacturers perhaps this isn't exactly a bad time to go looking for funds for electric racing?

## RACE MOVES

XPB



**George Tuma**, the owner of American historic motorsport organisation Historic Sportscar Racing LCC and a leading light on the vintage scene in the US, has died at his home in Germany. Tuma moved into governing body ownership after several seasons of racing in HSR categories, when he linked up with friend and business partner **David Hinton** to buy a majority ownership of HSR in 2012. In 2015 they were joined by **Jim Pace**.

**Jonny Baker** has joined Andersen Promotions in a newly created position of series development director for all three levels of its Road to Indy US single seater ladder. His role will involve acting as a liaison with current teams and drivers. Baker is a former driver and team manager and is co-founder, alongside **Anders Krohn**, of the CoForce consulting, marketing and digital agency. He most recently served as the general manager for Team Pelfrey's USF2000 and Pro Mazda racing programmes.

It's been reported that **Pat Fry** has re-joined McLaren as an engineering director as the team looks to bolster its technical team while awaiting the arrival of incoming technical director **James Key** from Toro Rosso – a move that's been held up due to contractual issues. Fry, who previously worked at McLaren from 1993 to 2010, was last in Formula 1 as an engineering consultant for Manor, before the team folded last year.

**Hugh Chambers** is the new CEO of the Motor Sports Association (MSA), the UK governing body. Chambers, who replaces **Rob Jones** in the position, has previously worked at Prodrive – where he was involved in its Subaru WRC programme and the BAR F1 effort – and more recently he has worked at World Sailing and at the British Olympic Association.

**Bryn Nuttall** is to take his BN Racing squad into Indy Lights next season. The Chicago-based team has been racing in the lower two categories on the Mazda Road to Indy US single seater ladder this year and will continue its programmes in Pro Mazda and USF2000 alongside its Indy Lights campaign in 2019.

British sports car and supercar maker McLaren Automotive has announced the appointment of **Brett Soso** as its new regional director for the Middle East, Africa and Latin America region. He succeeds **Andreas Bareis**, who is now vehicle line director for the Super Series.

Mechanics weren't forgotten when it came to doling out the Mazda Road to Indy prize fund, with **Ross McLeod** (Belardi Auto Racing) winning the Indy Lights Mechanic of the Year award, **Joe Penner** (Exclusive Autosport) the same honour in Pro Mazda and **Alan Oppel** (Cape Motorsports) getting the prize for US2000. Each was awarded with \$1000.

Specialist automotive PR agency PFP Communications has made 'significant' changes to its senior partnership team. Its CEO and founding partner **Peter Rawlinson** is now the sole shareholder of the business following the retirement of chairman and founding partner **Peter Frater**. The day-to-day operations will continue to be led by the firm's managing director, **Peter Cox**.

**Jeff Meendering**, the crew chief on the No.00 Stewart-Haas Racing car in the NASCAR Xfinity Series, was fined \$5000 after the Ford he tends was found to be running with improperly secured lug nuts after the Road America round of NASCAR's second tier championship.

**Kyungtai Ju** is now the president of Kumho Tire Europe. He replaces **Changrin Suk**, who will return to Kumho's Korean headquarters to take on responsibility for global sales. Ju has held a variety of positions at Kumho, a company he has now served for almost 30 years, having started his career at the firm in 1990.

**Shelley Unser**, the former wife of **Al Unser Junior**, has died. She had been a popular figure in the IndyCar paddock as an active member of the motorsport media in the past, and also for the time she spent volunteering with the Championship Auto Racing Auxiliary fundraising organisation.



While Electric GT is not strictly a spec series the regulations are such that only the Tesla P100DL will be able to compete, at least for its first year in 2019

**OBITUARY – Don Panoz**



**Don Panoz, the man who brought Le Mans prototypes back to the US in 1998, founded the American Le Mans Series and the Panoz racing and automotive businesses, along with other ventures outside motoring, has died at the age of 83.**

During his colourful, and cigarette-fuelled, life Panoz made a fortune from transdermal patches that are designed to help smokers kick the habit, built the Chateau Elan hotels outside his home racing circuit, Road Atlanta in Georgia, and another at Sebring in Florida, created a vineyard and winery in Georgia, and developed golf resorts in Florida, California, Scotland and Australia.

He was justifiably proud of his racing series, which started in October 1998 against a failing FIA GT Championship, giving European manufacturers Audi and BMW a place to race their Le Mans cars against Cadillac and his own Panoz racecars. This was, for years, the place to be, until Europe caught on to the idea and the European Le Mans Series was created.

In 1997 Panoz worked with Reynard Motorsports to produce the Esperante to take on Mercedes, Porsche and McLaren in the FIA GT Championship. The following year, he worked with Zytek to create a hybrid-electric version of the car, the Q9 that the drivers called 'Sparky'.

Panoz then brought back front-engine LMP1 cars to race against the mighty Audi R8s. He also brought back to racing Jan Magnussen, who had taken a break after his F1 career faltered. The Dane finished

on the podium at Sears Point in 2001, and celebrated by completing a series of donuts in the pit lane for which he was fined heavily. Don, approving of his driver's conduct, paid the bill.

Then came the LMP-07, the Esperante GTS and GTLM, the Abruzzi and Avezzano GT4, all unusual cars, the latter being part of the production car family started by Dan Panoz, with his father Don, in 1989. Panoz also continued his drive to promote green technology, partnering with US authorities to promote bio-ethanol fuel in the ALMS, and put funding and support behind concepts such as the DeltaWing. At Le Mans in 2017 he unveiled plans to run a hybrid GT car, the Green4U, with hot swap battery capability.

His was an unusual mix of philanthropy and hard business sense. He loved his cars, he loved racing, and he quite enjoyed a fight, particularly against major corporations, such as Nissan. Often he was to be found sitting on a golf cart, drawing on a cigarette, ready to give a wealth of background on any story.

One of his great achievements was, to the surprise of those who knew both men, burying the hatchet with Jim France, who ran the Grand Am series, and together they created the IMSA WeatherTech Sportscar Championship, taking the best of both series, from personnel and regulations to the teams and the race tracks.

There is a lot that racing owes to Don Panoz, not least the legacy of the 1000-miles Petit Le Mans in Atlanta, which started 20 years ago and will this year pay respect to its founder, a key player in motor racing history.

**Don Panoz 1935-2018**



Panoz's cars competed at Le Mans in the late 1990s and through the 2000s

**RACE MOVES – continued**

**Barrie 'Whizzo' Williams**, one of British motorsport's greatest characters, has died at the age of 79. A well-known and popular figure in paddocks throughout the UK for over 50 years Whizzo had a successful driving career, racing in just about everything, but he is best known for his success in saloon cars and more latterly historics. Outside of the driver's seat he was president of the British Motorsport Marshals' Club.

**Bob Fernley** was an early casualty of the purchase of the Force India team by the **Lawrence Stroll** led consortium that now owns it. As deputy team principal, Fernley filled in for often absent former boss **Vijay Mallya** on race weekends. He had held this post since the team (which had previously been known as Jordan, Midland and Spyker) became Force India in 2008. **Otmar Szafnauer** is now managing the Silverstone-based operation.

**Phil Popham** has been appointed senior vice president, commercial operations, for Group Lotus and CEO, Lotus Sports Cars. Popham joins Lotus from luxury boat builder Sunseeker International, where he held the role of CEO for four years. Prior to that he was part of the Jaguar Land Rover executive team for nine years with global responsibility for commercial operations.

**Uday Senapati** has also joined Group Lotus (see above), taking responsibility for product strategy and management of all current and future product lines from the famed sports car maker, including digital products and services. Senapati has held technical management roles at both GM and JLR and most recently held senior management positions at Bentley Motors.

**James Gourlie**, a 25-year old engineering student at RMIT University in Bundoora, Australia, has won the Infiniti Engineering Academy 2018 for the Asia and Oceania region. Gourlie's prize is a six-month work placement at the Renault Formula 1 team in Enstone and a further six months at Infiniti's Technical Centre Europe in Cranfield.

**Bill Gwynne**, the founder of the British Association of Rally Schools and also the owner of the well-known rally driving school that bears his name, has died at the age of 78. He started his motorsport career racing motocross bikes in the 1950s before switching to rallying in the 1970s.

NASCAR Cup crew chief **Chad Johnston** was fined \$10,000 after the No.42 Chip Ganassi Racing Chevrolet he tends was discovered to be running with improperly fitted lug nuts at post race inspection at the Darlington Raceway round of the series.



**Charly Lamm** (63), a legendary figure on the European touring car and sportscar scene, is to step down from his position as the boss of Schnitzer Motorsport at the end of this year. Lamm led Schnitzer to numerous wins and titles as a works BMW team, including running the BMW prototype that won Le Mans in 1999. **Herbert Schnitzer Jr** will now take over. He is the son of **Herbert Schnitzer Sr**, Lamm's half-brother, who co-founded Schnitzer with his brother Josef in the 1960s.

◆ Moving to a great new job in motorsport and want the world to know about it? Or has your motorsport company recently taken on an exciting new prospect? Then email with your information to **Mike Breslin** at [mike@bresmedia.co.uk](mailto:mike@bresmedia.co.uk)



NEW UK TRADE EVENT

# M&S D

## MotorsportDays LIVE

THE   
**SILVERSTONE**  
**WING** CONFERENCE & EXHIBITION CENTRE  
**02-03 NOVEMBER**  
**2018**



**£10 OFF**  
YOUR TICKET  
WHEN USING DISCOUNT CODE:  
**RACECE10**  
BUY YOUR TICKET ONLINE AT  
[WWW.MOTORSPORTDAYS.LIVE](http://WWW.MOTORSPORTDAYS.LIVE)

# # GETTING YOU ON TRACK

[WWW.MOTORSPORTDAYS.LIVE](http://WWW.MOTORSPORTDAYS.LIVE)

TEL: +44(0)1732 642755 EMAIL: [BEN@MOTORSPORTDAYS.COM](mailto:BEN@MOTORSPORTDAYS.COM)

EVENT PARTNERS



ASSOCIATED SUPPORT



To book a ticket or to discuss your involvement and/or interest in the event by phone please call Ben on +44(0)1732 642755. Ticket price will include show guide. Early bird tickets RRP. £25 only available until 30/09/18 and will increase after this date. All advanced tickets are available until Midnight Thursday 1<sup>st</sup> November 2018. After that, all tickets will be available on the day(s) of the show. All information correct at time of publishing. Terms & conditions apply. MotorsportDays.LIVE is produced by BWR Media Ltd.

SUPPORTING  
**MISSION MOTORSPORT**



# Can F1 hit the Bullseye?

## PIT CREW

**Editor**

Andrew Cotton  
 @RacecarEd

**Deputy editor**

Gemma Hatton  
 @RacecarEngineer

**News editor and chief sub editor**

Mike Breslin

**Art editor**

Barbara Stanley

**Technical consultant**

Peter Wright

**Contributors**

Mike Blanchet, Nick Bailey, Sam Collins (associate editor), Ricardo Drivla, Simon McBeath, Danny Nowlan, Mark Ortiz, Claude Rouelle, Martin Sharp, Sam Smith

**Photography**

James Moy, Katy Fairman

**Deputy managing director**

Steve Ross Tel +44 (0) 20 7349 3730  
 Email steve.ross@chelseamagazines.com

**Advertisement Manager**

Lauren Mills Tel +44 (0) 20 7349 3796  
 Email lauren.mills@chelseamagazines.com

**Sales Executive**

Stephen Upfold Tel +44 (0) 20 7349 3775

Email stephen.upfold@chelseamagazines.com

**Circulation Manager** Daniel Webb

Tel +44 (0) 20 7349 3710

Email daniel.webb@chelseamagazines.com

**Publisher** Simon Temlett

**Managing director** Paul Dobson

**Editorial and advertising**

Racecar Engineering, Chelsea Magazine Company, Jubilee House, 2 Jubilee Place, London, SW3 3TQ  
 Tel +44 (0) 20 7349 3700  
 Fax +44 (0) 20 7349 3701

**Subscriptions**

Tel: +44 (0)1858 438443  
 Email: racecarengineering@subscription.co.uk

Online: www.subscription.co.uk/chelsea/help

Post: Racecar Engineering, Subscriptions Department, Sovereign Park, Lathkill St, Market Harborough, Leicestershire, United Kingdom, LE16 9EF

**Subscription rates**

UK (12 issues) £89  
 ROW (12 issues) £100  
 racecar@servicehelpline.co.uk

**Back Issues**

www.chelseamagazines.com/shop

**News distribution**

Seymour International Ltd, 2 East Poultry Avenue, London EC1A 9PT

Tel +44 (0) 20 7429 4000

Fax +44 (0) 20 7429 4001

Email info@seymour.co.uk

**Printed by** William Gibbons

**Printed in England**

ISSN No 0961-1096  
 USPS No 007-969



www.racecar-engineering.com

One evening I was put in charge of the TV remote control and we finished up watching the former prime time favourite darts show, Bullseye. The set was cheap, the concept even more so, and when the world number one arrived to try to throw three sets of treble 20, but finished up scoring about 90 points in total, I realised why this was such good TV. It was just a bit rubbish, but it had a human element to it that could not be faked.

A few weeks later, I was again entrusted with the remote, and we finished up watching a re-run of the 1981 Las Vegas Grand Prix. The crowds, put into grandstands at one end of the circuit, were leaning up against the barriers, but they could see the entire track, and so even in the heat of the day they were able to enjoy the whole race. They probably weren't charged an arm and a leg for the privilege too.

It made me think more carefully about the predicament in which F1 finds itself today. The crowds still want to go, they still want to get close to the cars and see some great racing.

More than anything, they want to see the drivers, and equally, the drivers appear *not* to want to see them. It's a duty, rather than a pleasure, and that's a shame for those who queue for hours, and get little in return.

Talking to Doug Fehan, programme manager of Corvette Racing, about his time running Dale Earnhardt Snr at the Daytona 24 hours in 2001, he talked of the man in revered

tones. This was a superstar who one day every year would sit outside his workshop, and sign autographs. According to Fehan, at one stage a heavily pregnant woman who had been stood in line all day approached the table. She was after an autograph for her husband's birthday and Earnhardt considered that she perhaps deserved more for her effort. He signed his own jacket, and handed that to her instead. It was a mark of respect that he should look after a fan like this.

Why write about all this in a technical motorsport magazine? Well, I believe it relates directly to the state of Formula 1 today, and the efforts of Ross Brawn and his team to create something for the fans at the track and on television that will keep them committed to watching Formula 1.

The whole shooting match is paid for, in one way or another, by those who part with good money to watch these 20 cars race, or those who buy products around the sport, such as cars or goods. Keeping them happy is the number one priority, and the plan is to do so through technology.

Close racing is the key, say the research team. But I doubt that hugely. Back in Vegas In 1981, Alan Jones was more than

40 seconds up the road at mid-distance, and no one looked at that and said 'oh, dear, we have to get everyone closer or we will lose the crowd.' To be fair there was no crowd there anyway, so such a loss would not have been noticeable.

Formula 1, and other areas of motorsport, have all tried hard to find new ways of 'connecting' with the audience. E-sports, infernal computer games designed to allow members of the public to race against the elite, are springing up all over the place. WEC Championship promoter Gerard Neveu noted my disdain at the game around that series, but figured it is a necessary step to maintain enthusiasm.

But why pretend, with made up racing games? Let's face it, nothing is as spectacular as watching Marc Gene's lap of Road Atlanta in a 2003 Ferrari with the volume up full; or what about Ferdinand Hapsberg trying to win at Macau in 2017? Or Ayrton Senna's qualifying lap of Monaco in 1988 – incidentally, Lewis Hamilton's qualifying lap in Singapore may not have been quite as extraordinary as Senna's, but it is probably a seminal moment in his rivalry with Sebastian Vettel.

However, the core point is that Brawn and his team are looking for a way to put the genie back into the bottle. Can they overcome the advances in aero development, suspension, hybrid technology, and advanced fuels, and make that relevant to the spectator? Or, is Formula 1 asking itself the wrong question entirely; how should

the sport relate to the spectator? Should they be using road car-relevant hybrid systems and just get on with it? Should they start using cars that fans can identify with? Clearly not. A Formula 1 car with an Audi A4 bodyshell on it would be daft.

Should they therefore just go to the extreme, and make these cars fast, loud, frightening to watch and even more frightening to drive? Or, should they just go super safe and put everything online, leaving us with nothing more than a contest for programmers in their underpants, in their bedrooms, making remote objects travel quickly?

Everyone is trying to keep the Formula 1 ship afloat, but the ship is too big, carries too many people, and is slow and cumbersome because of all the people on it. People don't pay money to watch a massive ship sail around the world. It's impressive, but perhaps now is a time to put everyone in speed boats, and see who makes it. Reduce the size of teams, improve diversity throughout the sport, and create Formula 1 cars that are exciting to watch.

**ANDREW COTTON** Editor

**Should they just go to the extreme and make F1 cars fast and loud and frightening to watch and drive?**

To subscribe to Racecar Engineering, go to [www.racecar-engineering.com/subscribe](http://www.racecar-engineering.com/subscribe) or email [racecar@servicehelpline.co.uk](mailto:racecar@servicehelpline.co.uk) telephone +44 (0) 1795 419837

\* Racecar Engineering, incorporating Cars & Car Conversions and Rallysport, is published 12 times per annum and is available on subscription. Although due care has been taken to ensure that the content of this publication is accurate and up-to-date, the publisher can accept no liability for errors and omissions. Unless otherwise stated, this publication has not tested products or services that are described herein, and their inclusion does not imply any form of endorsement. By accepting advertisements in this publication, the publisher does not warrant their accuracy, nor accept responsibility for their contents. The publisher welcomes unsolicited manuscripts and illustrations but can accept no liability for their safe return. © 2018 Chelsea Magazine Company. All rights reserved.

\* Reproduction (in whole or in part) of any text, photograph or illustration contained in this publication without the written permission of the publisher is strictly prohibited. Racecar Engineering (USPS 007-969) is published 12 times per year by Chelsea Magazine Company in England.



# WORLD'S FIRST **ONLINE** Motorsport Engineering Degrees

**BSc (Hons) Motorsport Engineering\***

**NEW - MSc Advanced Motorsport Engineering\***

\*Degrees awarded by our Academic partner De Montfort University.



**NEW ACADEMIC YEAR – NEW PARTNERSHIP!**



The National Motorsport Academy is delighted to announce its new partnership with De Montfort University, Leicester (DMU).

DMU is a university ranked Gold in the 2017 Teaching Excellence Framework (TEF), the only Government-endorsed measure of teaching quality in higher education.



The University is also placed highly in World rankings, for its outstanding programmes in Engineering and Technology.

This exciting new partnership will enable NMA to continue to deliver the World's **ONLY** Online, Motorsport Engineering **Bachelors (BSc Hons) & Masters (MSc)** Degree courses, as well as offer excellent opportunities to our valued students, who will be awarded their degree by DMU.

The learning experience will be enhanced through access to DMU's considerable resources and award-winning student support services. But it won't end there because as a DMU alumnus/alumna, **#DMUforlife** will keep students informed about the lifelong benefits they can access, from career support and discounted further study, to a chance to travel the world with **#DMUglobal**.

**Apply **ONLINE** Now & Accelerate **YOUR** Motorsport Career!**

<https://motorsport.nda.ac.uk>



**+44 (0)1159 123456**

# 3D Printing is an Amazing Tool.

**However, if you can't fit every 3D Printing process into your toolbox... it's time to outsource.**

- Design Verification
- Over-molded Parts
- Full Color 3D Printing
- Marketing Models
- Aerodynamic Testing
- Jigs and Fixtures
- Color Matched Castings
- Replacement Parts
- Short-run Production
- Large and Complex Parts
- Clear and Tinted
- Full Paint and Finishing

Since 1998, CIDEAS Inc. has provided millions of Additive Manufactured and 3D Printed parts to tens of thousands of customers.

Our experienced and dedicated team of project managers, engineers, and finishers are always willing to go the extra mile or kilometer, for you and your needs.

**BUILDPARTS.COM | +1 847.639.1000**

**Additive Manufacturing and 3D Printing Services**

 **ideas**  
BUILDPARTS.COM | Since 1998