

User manual

Introduction

Thank you for your choice of FULL DUPLEX WIRELESS COMMUNICATION SYSTEM. (Base Unit: FLX2000/ Wireless Headset :ComStar S)

This is a DECT (Digital Enhanced Cordless Telecommunications) walkphone. To the quality of audio and to the safety offered from the digital technology, FLX2000/ComStar S offers manifold and useful features including **Full duplex system, LED In use illumination**, multi-headset capabilities and multi-volume select. Please read this instruction carefully before using your new walkphone for the first time.

Please check your package that included the following items:

- Base Unit (FLX2000)
- Wireless Headset (ComStar)
- Cord Headset (Max 3G)
- AC / DC adaptor for Base Unit
- One base packing batteries
- One headset packing batteries
- User manual

User manual contents

Introduction	2
Contents in your package	2
User manual contents	3
FCC Statement	3
A glance guide for the headset	4
A glance guide for the Base Unit	4
Installation	5
Charging the headset batteries	5
Basic Functions	6
Make a talk	6
End a talk	6
Mute	6
Headset Power on / off	6
Out of range indication	6
Registration	7
Unsubscribe headset registered	7
Conference talk	7
Specification	7
Customer Service Contact Information	8

FCC Statement

This device complies with part 15 of the FCC Rules. Operation is subject to the following two conditions: (1) This device may not cause harmful interference; and (2) This device must accept any interference received, including interference that may cause undesired operation.

FCC RF Radiation Exposure Statement:

This equipment complies with FCC RF radiation exposure limits set forth for an uncontrolled environment. This transmitter must not be co-located or operated in conjunction with any other antenna or transmitter. For base unit it should be installed and operated with a minimum distance of 20 centimeters between the radiator and your body..

WARNING:

Changes or modifications to this unit that are not expressly approved by the party responsible for compliance could void the user's authority to operate the equipment.

Privacy of communications may not be ensured when using this product!

Note: This equipment has been tested and found to comply with the limits for a Class B digital device, pursuant to part 15 of the FCC Rules. These limits are designed to provide reasonable protection against harmful interference in a residential installation. This equipment generates uses and can radiate radio frequency energy and, if not installed and used in accordance with the instructions, may cause harmful interference to radio communications. However, there is no guarantee that interference will not occur in a particular installation. If this equipment does cause harmful interference to radio or television

reception, which can be determined by turning the equipment off and on, the user is encouraged to try to correct the interference by one or more of the following measures:

- Reorient or relocate the receiving antenna.
- Increase the separation between the equipment and receiver.
- Connect the equipment into an outlet on a circuit different from that to which the receiver is connected.
- Consult the dealer or an experienced radio/TV technician for help.

A glance guide for the headset

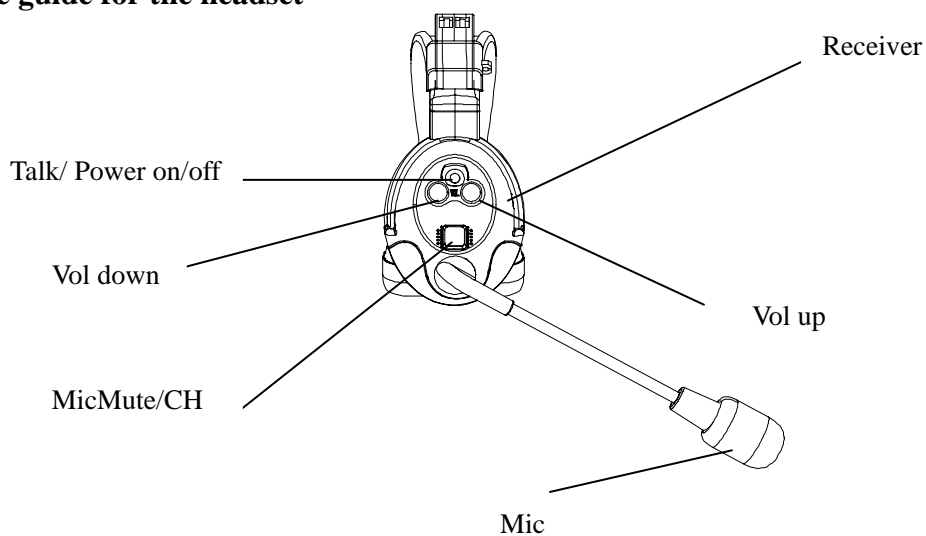

A glance guide for the base unit

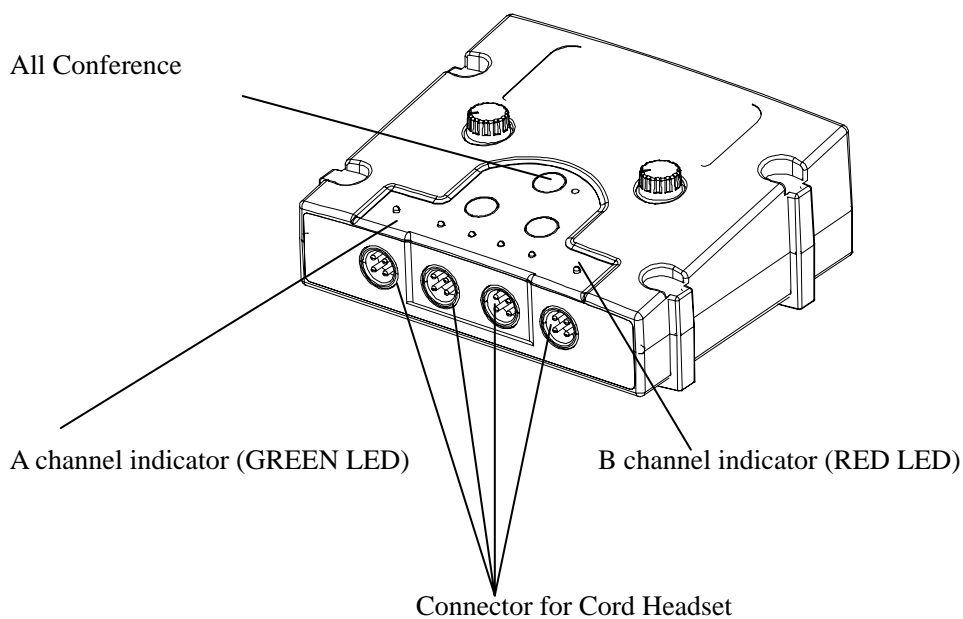

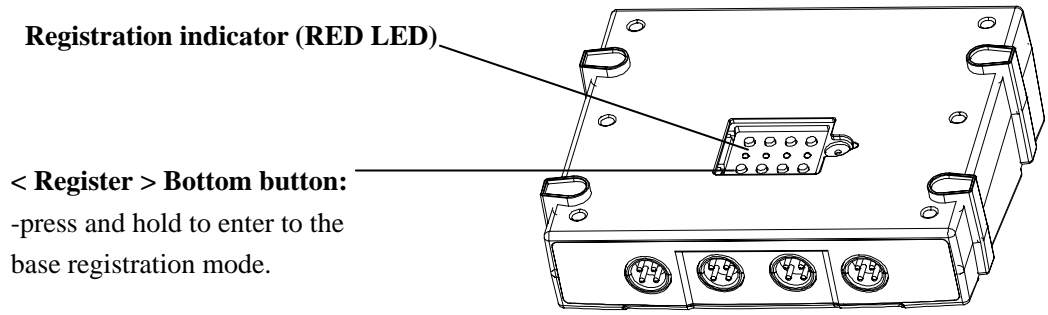

Installation

Choose a suitable site for the base unit; make sure it is not near to other electrical equipments.
Connect the AC adaptor socket to the Base Unit and to your room's power socket.
Turn on the power of base.

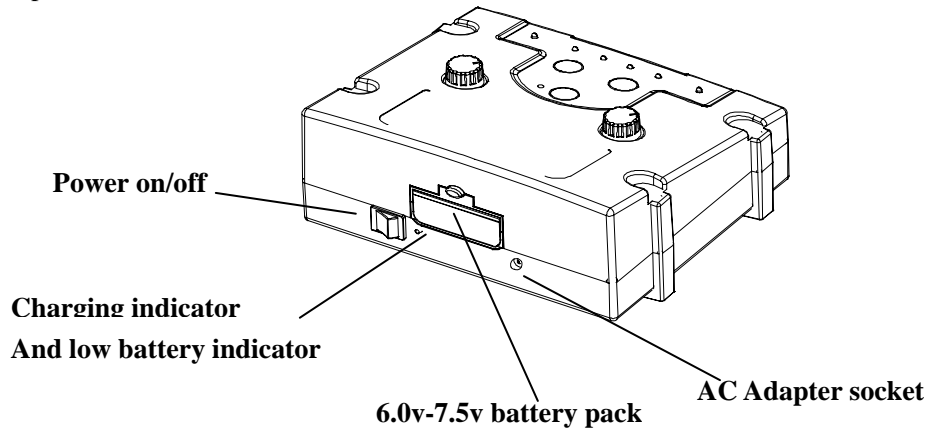

Fitting the battery in the headset:

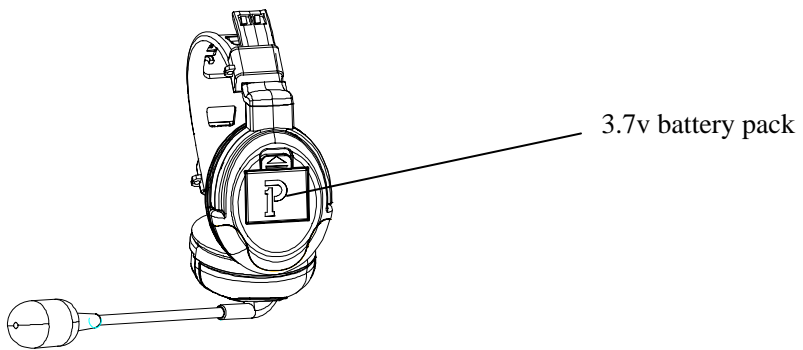

- The pack rechargeable batteries come with your charger.
- Insert the rechargeable battery into the headset as the above figure indicated, matching correct polarity.
- Fit the battery compartment cover by sliding it down so that it clicks firmly into place.

NOTE: Reversing the orientation may damage the headset. Please use the battery type supplied or recommended equivalents. A different battery could cause an explosion or damage of your headset.

Charging the headset batteries

Before using the headset, charge the headset for at least 6 hours.

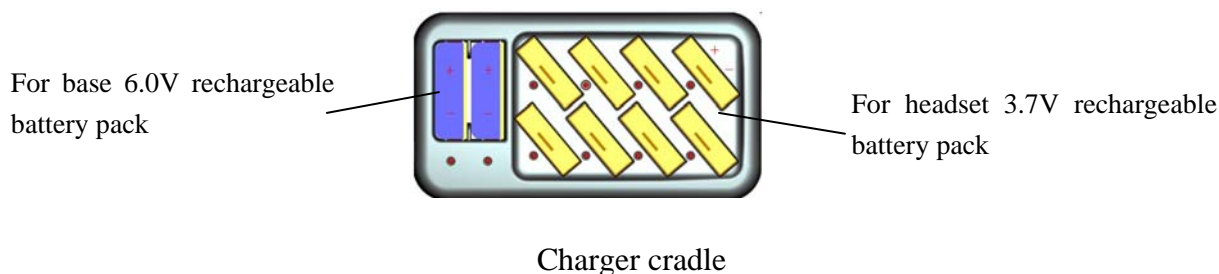

Whenever you see the low battery **indicator LED** flash on the headset, or you have heard the low battery warning tones during a call conversation, please:

- End the call as soon as possible.
- Change the headset battery.

To charge the battery, put the battery into the charger cradle. The charging LED on charger unit will come on to indicate that the battery is in charging mode.

Basic Functions

Make a talk

-Press **“Talk”** key to get the headset, the **“In use”** LED is ON.

During a talk conversation, you can adjust the talk volume (1 ~ 5 levels) by simply pressing ▲ or ▼ key.

End a call

-Press **“Talk”** key, the **“In use”** LED is OFF.

Mute

-During a call conversation, you can mute your voice by pressing **“Mute/CH”** key, the headset will show mutetone that you can talk freely without be heard by the talk party, and you still be able to hear the talk party.

-Deactivate the mute function, press **“Mute/CH”** again.

Headset Power On / Off

To power Off the headset

- Press and hold **“Talk”** key about 3 seconds, the headset will switch off which can prolong the use time of headset.

To power On the headset

-Press **“Talk”** key

The headset will power on with the **“In use”** LED light about 10 seconds, then the headset will return to the

standby mode.

Out of range indication

If your headset has registered and is in located range, the “In use” LED will blanking steadily, when your headset goes out of range, the communication link will be lose temporarily, the “In use” LED will blink.

If you go back to the located range again, the communication link will restore, also the “In use” LED will blanking steadily.

Note: your talk will be cut without any audible warning tone if you are in a talk and out of the located range.

Registration

The headset and base shall be factory pre-registered with the identification digital security codes, which are stored into the non-volatile memory, so that your headset shall be ready for working after out-of-box. However, your headset shall also has a procedure to allow you to re-do the registration operation in case of the link is lost accidentally.

-press ▼ key 3 times, Press and hold ▲ key for 3 seconds on the headset “In use” LED is ON, your headset entered the registration mode

-Press and hold **SUB** key for 3 seconds on the base until “SUB” LED is ON, the base also entered the registration mode.

Note: SUB key A1-A4 is for channel A station, B1-B4 is for channel B station.

-About 5-10 seconds the headset “In use” LED is OFF that means the headset has located the base, and the base until “SUB” LED is OFF too.

-If the headset does not locate the base, the headset “In use” LED will be blink after 15 seconds and it will return to the non-located mode. Try again and check that you are not in the interference environment

Note: your base can register up to eight headsets. One headset register on the every subscribe key.

Unsubscribe headset registered

-At standby mode

-Press and hold **SUB** key enter the base’s registration mode with the “SUB” LED is ON

-Press and hold **SUB** key again until the “SUB” LED is OFF

-All headsets registered to this part are cleared

Note: (1)SUB key A1orA2 to unsubscribe both A1 and A2.

(2)SUB key A3orA4 to unsubscribe both A3 and A4.

(3)SUB key B1orB2 to unsubscribe both B1 and B2.

(4)SUB key B3orB4 to unsubscribe both B3 and B4.

Conference talk

When you are in a talk on the base, you can invite another channel headset to join your conversation.

-Press the “All Conference” key on the base that you want to talk.

-At the all conference mode, both wireless headset and four cord headsets can conference. But when you use cord phone to a conference, though there are four cord headset interfaces, you can only use two cord headsets, the other two headsets only for support when necessary

-Press the “All Conference” key on the base once again, turn off the all conference mode.

Specification

Standard	DECT6.0 (Digital Enhanced Cordless Telecommunications)
Frequency	1920 ~1930GHz (USA)
Frequency	1880 ~1900GHz (EURO)
Channel Bandwidth	1.728 MHz
Modulation type	GFSK
Transmission speed	1.152 Mbps (Baud rate)
Duplexing	Time Division Duplex (TDD)
Speech encoding	ADPCM / 32kbit/s
RF Accessing	Time Division Multiple Access (TDMA)
Channel	5(USA) 10(EURO)
Coverage range	50m indoor; 300m in open space
Base Power Supply	AC/DC adaptor: INPUT 110-240Vac; OUTPUT 9.0Vdc 1000mA
Headset Power Supply	Rechargeable battery: 3.7V/ 1000mAh
Charge Time initially	6 hours
Operation time	100 hours in standby; 10 hours in talk
Normal condition of use	0 °C to 40 °C
Storage Temperature	-10°C to 60 °C

Customer Service Contact Information

PORTA Customer Services can be contacted by calling 1-xxx-xxx-xxxx
7 days a week, 24hrs a day.

If you believe your equipment is defective or missing components, please contact PORTA Customer Service at 1-xxx-xxx-xxxx, Monday – Friday, 8 a.m. to 5 p.m. PST

LIMITED WARRANTY

This limited warranty only applies to the use of this device with a communications service for which it is designed. This device alone does not provide the customer with any communications service and requires a separate subscription to a communications service from a service provider. Altering service provider-specific settings may void the warranty. This limited warranty does not warrant that the device will be free of any limitations of voice quality or service caused by (1) the services provided by the customer’s underlying communications service provider; or (2) interference from other radio frequencies or transmissions, static electricity, and other electronic devices.