

System Integration Manual

Powerwave[®]
technologies

THE POWER IN WIRELESS™

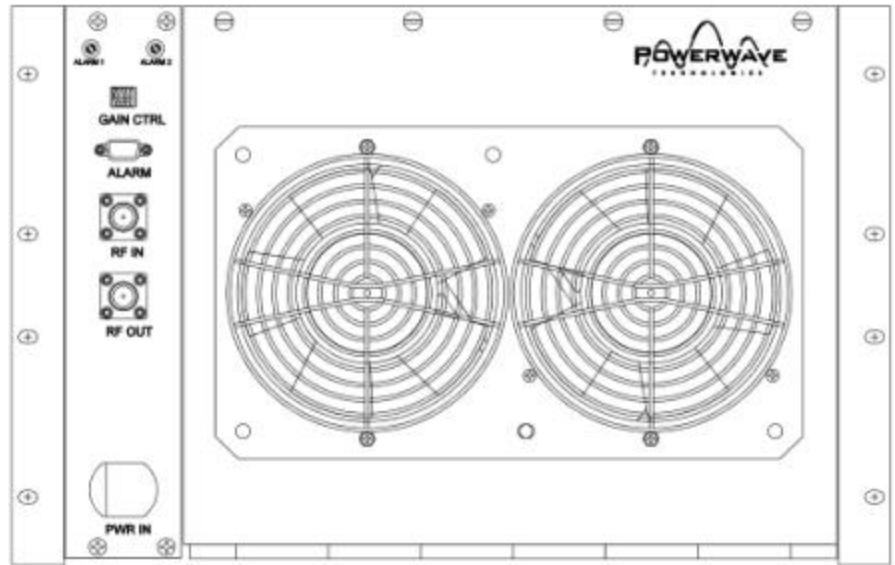

**Booster Amplifier Subrack (BAS) System
935-942 MHz, 91 Watts Nominal**

Table Of Contents

<u>Par.</u> <u>No.</u>	Section 1 General Description	<u>Page</u> <u>No.</u>
1-1	Introduction	1-1
1-2	General Description.....	1-1
1-3	Functional And Physical Specifications.....	1-2
1-3.1	MCR20930-1-2 Subrack Specifications	1-3
1-3.2	GL3-900 Series Amplifier Specifications	1-5
1-4	Booster Amplifier Subrack Major Components.....	1-8
1-5	Equipment Changes	1-8
Section 2 Installation		
2-1	Introduction	2-1
2-2	Site Survey	2-1
2-3	Electrical Service Recommendations.....	2-1
2-4	Air Conditioning.....	2-1
2-5	Unpacking and Inspection.....	2-2
2-6	Installation Instructions	2-3
2-7	Amplifier Module Power, Alarm, Control, and RF Connector.....	2-4
2-8	Remote Control and Status	2-5
Section 3 Operating Instructions		
3-1	Introduction	3-1
3-2	Initial Start-Up and Operating Procedures	3-1
Section 4 Principles of Operation		
4-1	Introduction	4-1
4-2	RF Input Signal.....	4-1
4-3	RF Output Load	4-1
4-4	System Functional Description.....	4-1
4-5	Multi-Carrier Power Amplifier Functional Description	4-2
4-5.1	Predriver Amplifier.....	4-3
4-5.2	Three Stage Driver Amplifier.....	4-3
4-5.3	Main Amplifier.....	4-3
4-5.4	Alarm Monitoring and Control.....	4-3
4-5.5	Loop Control Circuit	4-3
4-6	Amplifier Module Cooling	4-4
4-7	Power Distribution	4-4

Table Of Contents (Continued)

<u>Par.</u> <u>No.</u>	Section 5 Maintenance	<u>Page</u> <u>No.</u>
5-1	Introduction	5-1
5-2	Periodic Maintenance	5-1
5-3	Test Equipment Required For Test	5-1
5-4	Performance Test	5-2
5-4.1	Amplifier Performance Test	5-2
5-4.1.1	Amplifier Spurious Emissions Test	5-2
5-4.1.2	Gain Test	5-2
5-4.1.3	Input Return Loss	5-2
5-5	Field Replacement of the Module	5-5

Section 6
Troubleshooting

6-1	Introduction	6-1
6-2	Troubleshooting	6-1
6-3	Return for Service Procedures	6-1
6-3.1	Obtaining an RMA	6-1
6-3.2	Repackaging for Shipment	6-1

List Of Appendices

<u>Appendix</u>	<u>Page</u> <u>No.</u>
A	Booster Amplifier Subrack Backplane Wiring Diagram.....A-1
B	Distribution Printed Circuit Board Pinout LocationB-1
C	Power Setting ProcedureC-1

List Of Illustrations

<u>Figure</u> <u>No.</u>	<u>Page</u> <u>No.</u>
1-1	VVA, Voltage Regulator and Dip Switch Pin Configuration..... 1-2
1-2	Booster Amplifier Subrack System-Top View..... 1-9
1-3	Booster Amplifier Subrack System-Front View..... 1-10
1-4	Booster Amplifier Subrack System-Side View (Front Door Open)..... 1-11
1-5	Booster Amplifier Subrack System-Side View with Fans Removed 1-11
1-6	Booster Amplifier Subrack-Backplane 1-12
1-7	GL3-900 Series Amplifier 1-13

1-8 GL3-900 Series Amplifier – Rear, Top, Front Views 1-14
Table Of Contents (Continued)

List Of Illustrations (Continued)

2-1 J5 Alarm Connector..... 2-4
 2-7 Front Panel POWER IN Connector..... 2-5
 4-1 System Block Diagram..... 4-1
 4-2 G3L-900-50/60-005 Multi-Carrier Power Amplifier Functional Block Diagram..... 4-2
 5-1 G3L-900-50/60-005 Amplifier Test Setup Diagram..... 5-3

List Of Tables

<u>Table No.</u>		<u>Page No.</u>
1-1	Truth Table (Variable Attenuator)	1-2
1-2	Booster Amplifier Subrack System Specifications	1-3
1-3	2-Way Splitter Electrical Specifications	1-4
1-4	2-Way Combiner Specifications.....	1-4
1-5	G3L-900-Series Amplifier Electrical Specifications	1-5
1-4	G3L-900-Series Amplifier Mechanical Specifications	1-6
1-7	GL3-900 Series Amplifier Environmental Specifications.....	1-7
1-8	Major BAR System Components	1-8
2-1	Remote Control and Status Specifications	2-5
2-2	J5 Alarm Connector Pin Designation	2-4
2-3	Front Panel POWER IN Connector Pin Designations	2-5
5-1	Periodic Maintenance.....	5-1
5-2	Test Equipment Required.....	5-1
5-3	Multichannel Power Amplifier Test Data Sheet	5-4
6-1	Troubleshooting.....	6-1



© 2001 Powerwave Technologies Incorporated. All rights reserved.

Powerwave Technologies, and the Powerwave logo are registered trademarks

Powerwave Technologies, Inc. reserves the right to make changes to the documentation and equipment, including but not limited to component substitution and circuitry changes. Changes that impact this manual may subsequently be incorporated in a later revision of this manual.

January 2001



Powerwave Technologies, Inc.
1801 E. St. Andrew Place
Santa Ana, CA 92709

Tel: (714) 466-1000
Fax: (714) 466-5800
Web Site: www.powerwave.com

Section 1. General Description

1-1 Introduction

This manual contains information and procedures for the installation, operation, and maintenance of Powerwave Technologies, Inc.'s (Powerwave's) Booster Amplifier Subrack (BAS) system. This manual is organized into the following sections:

Section 1. General Description	Appendix A: Backplane Wiring Diagram
Section 2. Installation	Appendix B: Distribution PCB Pinout Location
Section 3. Operating Instructions	Appendix C: Power Setting Procedure
Section 4. Principles of Operation	
Section 5. Maintenance	
Section 6: Troubleshooting	

1-2 General Description

Engineered to operate in a 2-way transceiver paging base station, the BAS system is a linear, Multi-Carrier Power Amplifier (MCPA) system that operates in the 5 MHz frequency band from 935 MHz to 940 MHz. The system integrates the model MCR20930-1-2 Booster Amplifier Subrack (BAS) with two model G3L-900-50-005 MCPAs to deliver a composite RF output of 75.8 Watts (nominal), after combined losses. The system can also integrate two model G3L-900-60-005 MCPAs to deliver a composite RF output of 91 Watts (nominal), after combined losses.

Designed to function as a subrack (see Figures 1-2 thru 1-6) in the host base station, the enclosure has a one inch (right and left side) flanged front panel and eight mounting holes (four on each side) to secure the Subrack into place (refer to Figure 1-3 for mounting hole locations). To aid in maintaining the system's operating temperature, the BAS is equipped with two cooling fans mounted on the front access door (see Figures 1-3 and 1-4). The G3L-900-50-005 amplifier displaces 1,672 BTUs of heat at full power. The G3L-900-60-005 amplifier displaces approximately 1,900 BTUs of heat at full power.

The composite input signal is applied to a 30dB 10W input attenuator, followed by a voltage variable attenuator that is controlled via dip switches on the front panel (refer to Table 1-1 and Figure 4-1). The maximum composite input signal may not exceed +31dBm. The composite signal is then fed to a two-way power splitter. The signals are applied to the amplifiers, and the amplifier outputs are combined again (refer to Tables 1-2 through 1-7 for specifications). With both amplifiers installed, the system provides 20dB of gain.

The BAS also houses a distribution printed circuit board (PCB) for internal power and alarm distribution (refer to Appendix B). Accessible from the front panel is the DB9 external ALARM connector, the RF IN and RF OUT type N connectors.

Additionally, the front panel provides access to the +27 Vdc POWER IN connector, visibility of the two MCPA's fault alarm LED indicators and the GAIN CTRL dip switch. Refer to Table 1-1 for the dip switch truth table and Figure 1-1 for pin designations.

With the access door open, the two amplifier modules are visible. All solid-state, the MCPAs are designed for parallel operation for high peak power output. Their modular construction and unique and highly effective LED-based operational status and fault indicators help minimize downtime. The turn-on and turn-off sequence of voltages are fully automatic, as is overload protection and recycling. Inadvertent operator damage from front panel manipulation is virtually impossible. Refer to Figures 1-7 and 1-8 for drawing views of the amplifier module.

Table 1-1 Truth Table Input Variable Attenuator

Pin 1	Pin 2	Pin 3	Pin 4	Attenuation
+5Vdc	+5Vdc	+5Vdc	+5Vdc	0dB
+5Vdc	+5Vdc	+5Vdc	0Vdc	1dB
+5Vdc	+5Vdc	0Vdc	+5Vdc	2dB
+5Vdc	+0Vdc	+5Vdc	+5Vdc	4dB
+5Vdc	+5Vdc	+5Vdc	0Vdc	8dB
0Vdc	0Vdc	0Vdc	0Vdc	15dB

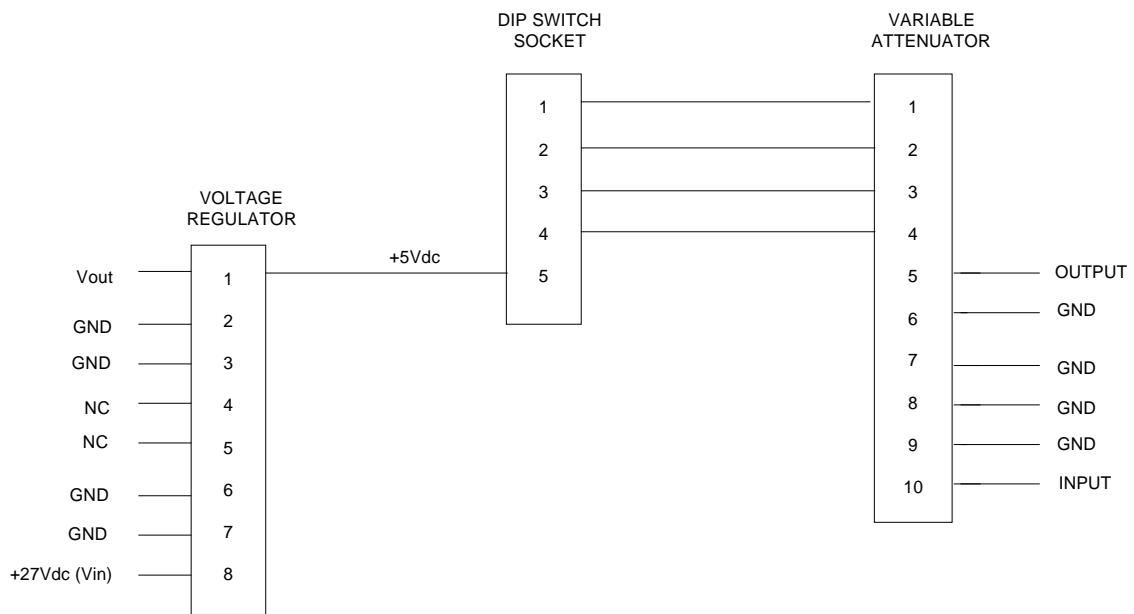

Figure 1-1 Variable Attenuator, Voltage Regulator and Dip Switch Socket Pin Configuration

1-3 Functional and Physical Specifications

The BAS system’s functional and physical specifications are listed in Table 1-2. A functional block diagram is provided in Section 4 of this manual to illustrate the system’s operational layout.

1-3.1 MCR20930-1-2 Subrack Specifications

Table 1-2 MCR20930-1-2 Booster Amplifier Subrack System Specifications

Frequency	935-940 MHz
Gain	+20 dBm, \pm 0.2 dBm
RF Input Power	+31 dBm composite w/variable attenuator set to 0dB attenuation. +46 dBm composite w/variable attenuator set to 15 dB attenuation.
RF Output Power: G3L-900-50-005 G3L-900-60-005	+47 dBm (50 Watts) nominal, 60 Watts (max.) +47.8 dBm (60 Watts) nominal, 75 Watts (max.)
Phase Variation	\pm 5°
Alarms	+5 Vdc TTL
D.C. Power	+ 27 Vdc, 55 Amps max
Total System Return Loss	-19 dBm
Channel Spacing	12.5 KHz
Operating Temperature	0 to 65 degrees C
Subrack Dimensions	12.22(H)x*17(W)x24.5(D) inches
Weight (Fully assembled)	Approximately 80 Pounds (36.28 kilograms)

*Note: Does not include 1-inch right and left side mounting flanges.

Table 1-3 Electrical Specifications for 2-Way Splitter

Insertion Loss	-33dB Min. (TBD on actual part) -48dB Max.
Amplitude Balance	±0.2dB Max.
Insertion Loss Flatness Over Frequency	±0.3dB Max.
Input/Output Return Loss	-20dB Min.
Port to Port Phase Delta	±5 Degrees Max.
Port to Port Isolation	-20.0dB Min.
IP3 (Input Power = 5dBm)	-90dBc Min.
Power Handling (Fixed Attenuator)	20 Watts Max.
Power Handling (Variable Attenuator)	3.16 Milliwatts Max.

Table 1-4 Electrical Specifications for 2-Way Combiner

Insertion Loss	-0.6 dB (TBD on actual parts)
Amplitude Balance	±0.2dB Max.
Insertion Loss Flatness Over Frequency	±0.3dB Max.
Input/Output Coupled Port Return Loss	-18.0 dB Min.
Port to Port Phase Delta	±5 Degrees Max.
Port to Port Isolation	-20.0dB Min.
Power Handling	120 Watts
Sampling Coupler	-25dB ±1dB
Sampling Coupler Directivity	-18.0 dB Min.
IP3 (Input Power = TBD)	-100 dBc Min

1-3.2 GL3-900 Series Amplifier Specifications

Table 1-5 G3L-900 Series Amplifier's Electrical Specifications

Frequency Range	935-940 MHz
Channel Spacing	12.5 KHz
Output Power: GL3-900-50-005 GL3-900-60-005	+47 dBm (50 Watts) nominal, 60 Watts (max.) +47.8 dBm (60 Watts) nominal, 75 Watts (max.)
Input Power	-10.0 dBm max.
RF Gain GL3-900-50-005 GL3-900-60-005	+58.8 dB \pm 1.0 dB @ +27Vdc, 25 C. +58.8 dB \pm 1.0 dB @ +27Vdc, 25 C
RF Gain Flatness over the operating frequency range	\pm 0.1 dB over any 1.25 MHz (over the frequency range).
Gain Flatness:	\pm 0.5 dB (935 MHz – 940 MHz)
Normal Operating Voltage	+27 Vdc \pm 1V Nominal (\pm 5%) 1Vpp ripple (100-120 Hz) max.
Current Consumption: GL3-900-50-005 GL3-900-60-005	20 Amps @ 27 Vdc, 25 °C, Prf = 50 Watts average 27 Amps @ 27 Vdc, 25 °C, Prf = 50 Watts average
Abnormal Operating Voltage	+21 Vdc to below +26 Vdc. Above +28 Vdc to +29 Vdc.
RF Gain variation by Temp & Voltage	TBD
Gain Variation Over Dynamic Range	\pm 0.1 dB max./20 dB for 0 to –20 dB rated power output
Intermodulation Distortion	-65 dBc min. (Main signal power to Spurious @ (12.5 kHz)
In-Band Spurious	-55 dBc min @ +23 to +24 Vdc
Input/Output VSWR.	1.5: 1 max @ 65 \pm °C.
Load Stability	Infinite VSWR. all phases
Output Isolation	20 dB min. (shall incorporate an output isolator)

Table 1-6 G3L-900 Series Amplifier's Mechanical Specifications

Items	Specifications			
Physical Dimension of MCPA	Front panel: 342.5mm(W) x 99mm(H) x 3mm(D) Body: 288.8mm(W) x 95.3mm(H) x 446mm(D)			
Weight	Approximately 28.6 pounds (13 kilograms)			
Connector Type	D-sub, Hybrid, Plug-in Type RF connector: PKZ 26-0020 series straight plug type (Phoenix Co.) refers to attached drawing.			
MCPA Front Panel Switch	CKT Breaker. +27 Vdc Power Indicator			
Connector Description	Pin Outs			
	A1	RF Output	(Coaxial Contact)	
	A2	Ground	(Power Contact)	
	A3	+27 Vdc	(Power Contact)	
	A4	RF Input	(Coaxial Contact)	
	1	TX H	10	+27 V
	2	TX L	11	COM SV
	3	GND	12	AMP AO
	4	RX H	13	AMP A1
	5	RX L	14	AMP A2
	6	GND	15	AMP A3
	7	HERE LPA	16	NC
	8	FF LPA	17	NC
9	RESERVED			
Markings	TBD			
Front Panel LED Display	LED type: SMD			
RUN	GREEN (When MCPA is enabled)			
ALM	Red (When any alarm occurred, LED is on)			
DC	Green (When DC Power is ON, LED is on)			
MCPA Captive fastener	TBD			
Front Panel color & silk	TBD			

Table 1-7 Environmental Specifications for G3L-900 Series Amplifiers

Items	Specifications
Operating Temperature	0 to + 65 C
Storage Temperature	-40 to + 85 C
Relative Humidity	5 to 90% RH (non-condensing)
Operating Air Pressure	860 to 1060 mbar
Shock	40 m/s s* @ 22 ms half sinusoid shock
Pressure	Integral forced air cooling must operate correctly at up to 0.3 inches back.
Vibration	Bellcore TR-NWT-000063 (1 m/s*s0.1~200Hz)
Corrosion Resistance/ Salt Fog	The MCPAs shall comply with the requirements of Bellcore Technical Reference TA-NWT-000487, Issue 2, Section 4.12
Altitude	All specifications shall be met at an altitude up to 15,000 feet where the maximum external ambient temperature is decreased by 0.5 C/ 1000 feet above sea level. The MCPAs shall not sustain damage when being transported at altitude up to 40,000 feet or uniformly applied pressure to 30 PSIA.

1-4 Booster Amplifier Subrack (BAS) System Major Components

Table 1-8 lists the model numbers and descriptions of the major components that comprise the BAS system and the document number (if available) of the manual related to each component.

Table 1-8 Major BAS System Components

Model/PN	Description	Qty Per System	Expandable To
800-01292-001	Top Assembly, BAS II w/o Combiner Backplane	1	1
800-01294-001	Front Panel Assy	1	1
700-00901-001	Cable Assy, Power In	1	1
700-00902-001	Cable Assy, Amp Power	1	1
700-00903-001	Cable Assy, Amp Power	1	1
700-00904-001	Cable Assy, Fan	2	2
700-00905-001	Cable Assy, Amplifier	1	1
800-001296-001	Fan Assy	2	2
800-01297-001	Tray Assy	1	1
500-01425-001	PCB Assy, Power Distribution	1	1
MCR20930-1-2	Booster Amplifier Subrack	1	1
GL3-900-50-005 or GL3-900-60-005	50-Watt Amplifier 60-Watt Amplifier	2 2	2 2

1-5 Equipment Changes

Powerwave Technologies, Inc. reserves the right to make minor changes to the equipment, including but not limited to component substitution and circuitry changes. Changes that impact this manual may be incorporated in a later revision of the manual.

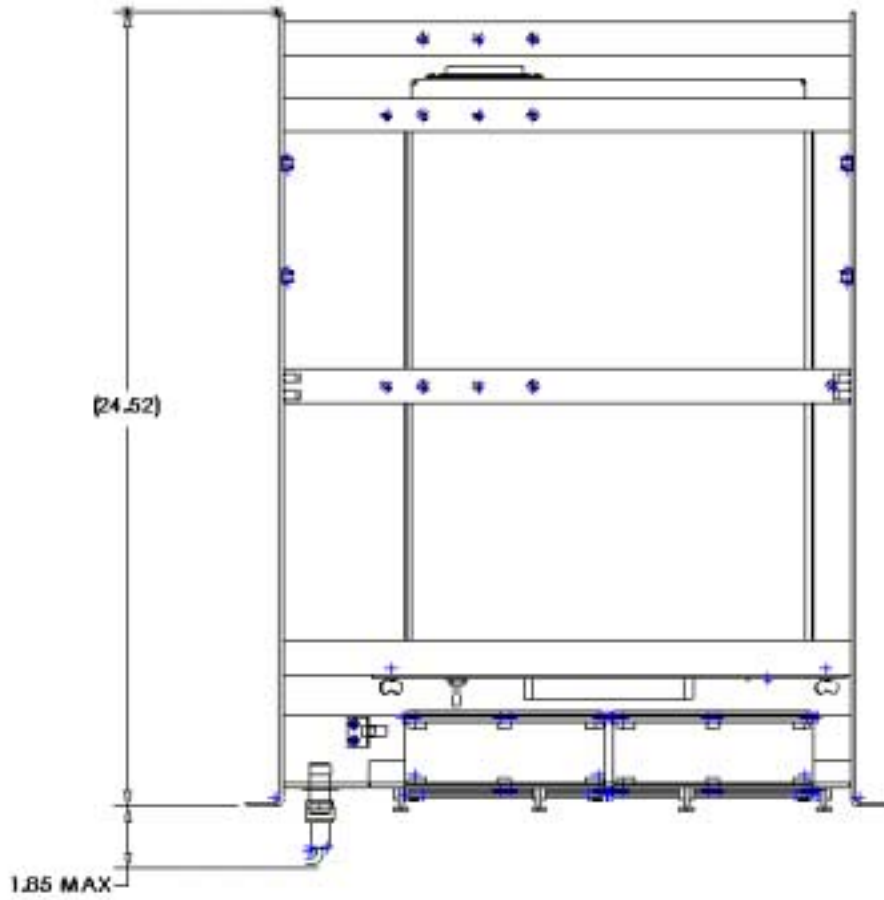

Figure 1-2 Booster Amplifier Subrack System – Top View

Section 2. Installation

2-1 Introduction

This section contains unpacking, inspection, installation instructions and recommendations for the Booster Amplifier Subrack (BAS) System. It is important that the licensee perform the following tasks correctly and in good faith:

1. Carefully read all material in this section prior to equipment unpacking or installation.
2. Also, read and review the operating procedures in Section 3 prior to installing the equipment.
3. If applicable, carefully review the Federal Communications Commission (FCC) rules as they apply to your installation. **DON'T TAKE CHANCES WITH YOUR LICENSE.**

2-2 Site Survey

Powerwave Technologies recommends that site surveys be performed by qualified individuals or firms prior to equipment ordering or installation. Performing a detailed site survey will reduce or eliminate installation and turn-up delays caused by oversights. Pay particular attention to power plant capacity, air conditioning needs, and RF/DC cabling/breaker requirements.

2-3 Electrical Service Recommendations

Powerwave recommends that:

- Proper AC line conditioning and surge suppression be provided on the primary AC input to the +27 Vdc power source.
- All electrical service should be installed in accordance with the National Electrical Code, any applicable state or local codes, and good engineering practice.
- Straight, short ground runs be used.
- The electrical service must be well grounded.

Circuit breakers should be thermal type, capable of handling the anticipated inrush current, in a load center with a master switch.

2-4 Air Conditioning

Each GL3-900-50-005 and GL3-900-60-005 amplifier generates 1672 BTUs and 1900 BTUs of heat respectively at full power. A fully populated MCR20930-1-2 Booster Amplifier Subrack system operating at full power will generate 3344 BTU's of heat (using two GL3-900-50-005 amplifiers) and 3800 BTUs (using two GL3-900-60-005) amplifiers. At least a 1/3-ton air conditioner is needed to cool this Powerwave equipment.

Unpacking and Inspection

This equipment (as applicable) has been operated, tested and calibrated at the factory. Carefully open and remove the MCPAs and model MCR20930-1-2 Booster Amplifier Subrack (BAS) from their respective containers. Retain all packing material that can be reassembled in the event that the unit must be returned to the factory. Please perform the following steps:

CAUTION

Exercise care in handling equipment during inspection to prevent damage caused by rough or careless handling.

1. Visually inspect the MCPAs and the BAS for damage that may have occurred during shipment.
2. Check for evidence of water damage, bent or warped chassis, loose screws or nuts, or extraneous packing material in the connector(s).

CAUTION

Before applying power, make sure that all connectors to the BAS components are secure. Make sure that the input and output of the BAS are properly terminated at 50 ohms. Do not operate the system without a load attached. Refer to Section 1, Table 1-2 for input power requirements. Excessive input power may damage the equipment.

If possible, inspect the equipment in the presence of the delivery person.

If the equipment is damaged:

- The carrier is your first area of recourse.
- A claim should be filed with the carrier once the extent of any damage is assessed. We cannot stress too strongly the importance of IMMEDIATE careful inspection of the equipment and the subsequent IMMEDIATE filing of the necessary claims against the carrier if necessary.

If the equipment is damaged and must be returned to the factory:

- Please write or phone for return authorization. Refer to section 6-3.1 of this manual for instructions.
- Powerwave may not accept returns without a return authorization.

Claims for loss or damage may not be withheld from any payment to Powerwave nor may any payment due be withheld pending the outcome thereof. **WE CANNOT GUARANTEE THE FREIGHT CARRIER'S PERFORMANCE**

2-5 Installation Instructions

The model MCR20930-1-2 Booster Amplifier Subrack (BAS) is designed for use in a 2-way transceiver paging base station. The host enclosure must permit access to the subrack for; DC power, RF and monitor cables. As well as, proper ventilation. The BAS system is designed for an enclosure with at least 36 inches of depth. Please proceed with installation as follows:

WARNING

Verify that all circuit breaker switches on the subrack are in the OFF position. Turn off external primary DC power before connecting DC power cables.

1. Install the subrack into the host base station and secure it into place using #10 32x1/2 Phillips screws and #10 flat washers.
2. Connect POWER IN (+27 Vdc) to the subrack. Refer to Figure 2-1 for pin locations and Table 2-2 for pin designations.
3. Connect RF IN cable to the subrack.
4. Connect RF OUT cable to the subrack.
5. Connect external ALARM interface to external summary board. Refer to Figure 2-2 for pin locations and Table 2-4 for pin designation.
6. Loosen thumbscrews to the front access door and open the door.
7. Before installing the MPCA into the subrack, inspect the 21-pin D-sub male combo connector on the rear of each amplifier. Verify that all pins are straight, no pins are recessed, and that the alignment shield is not bent.
8. Place power ON/OFF switch on the MCPA's front panel in the "off" (far-left) position.

WARNING

Do not slam amplifiers into the subrack. Forcing the amplifier into the subrack at too fast a rate may cause the pins on the 21-D-sub connector of the amplifier to become recessed or broken.

9. Insert a plug-in MCPA into the subrack. Tighten thumbscrews.
10. Repeat steps 7, 8 and 9 for the second MCPA.

WARNING

Check your work before applying DC voltage to the system. Make certain all connections are tight and correct.

11. Measure primary DC input voltage. DC input voltage should be +27 Vdc \pm 1.0 Vdc. If the DC input voltage is above or below the limits, call and consult Powerwave before you turn on your amplifier system.
12. Refer to Section 3 for initial turn-on and checkout procedures.

2-6 Amplifier Module Power, Alarm, Control, and RF Connector

The power, alarm, control, and RF connections on the amplifier are made through a 21WA4 male connector and are listed and described in Table 2-1 below and in Section 1, Table 1-4.

Table 2-1 MCPA Alarms & Controls

Items	Specifications	Remarks
Alarms & Controls	TTL Level; +5 Volts Buffer: 74ABT244 (5V) - recommended	
Deletion Alarm	When unit does not exist (HEAR_PAU) Equipped: GND Deletion OPEN	D-Line
Function Fail Alarm	When unit does not exist (HEAR_PAU) Normal: High Abnormal GND	D-Line
VSWR Alarm	3:1 (6dB ± 1dB) @ 35dBm-48dBm Output Power. PAU remains normal operation when this alarm condition disappears (NOT shutdown)	RS-485
High Temp. Alarm	This alarm only at +75°C. +5 °C/-0 °C	RS-485
Over Power Output Alarm	@output power is greater than +48.5 dBm ±0.5dB. MCPA will recover when the alarm condition disappears. (NOT shutdown).	RS-485
DC Fail Alarm	@ +20.5 Vdc ± 0.5V or +29 Vdc ± 0.5V. When this alarm occurs the MCPA shall shut-down	RS-485
Loop Fail Alarm	When an alarm occurs on the feed forward path.	RS-485
EN/DISABLE	Reserved	RS-485

The Alarm Interface connector on the front panel of the MCR20930-1-2 Booster Amplifier Subrack is a 9-pin female D-sub connector that permits serial interface with the external alarm monitor. Refer to Figure 2-1 and Table 2-3 for connector definition.

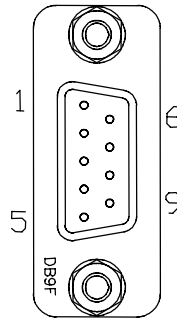

Figure 2-1 J5 Alarm Connector

Table 2-2 J5 Alarm Connector Pin Designation

Pin	Description
1	HERE_PAU-1
2	FF_PAU-1
3	DC_ON/OFF_1
4	PAU_RST_1
5	HERE_PAU_2
6	FF_PAU_2
7	DC_ON/OFF_2
8	PAU_RST_2
9	No Connection (NC)

2-7 Remote Control and Status

Refer to Table 2-3 for a description and list of remote control and status specifications for the MCPA.

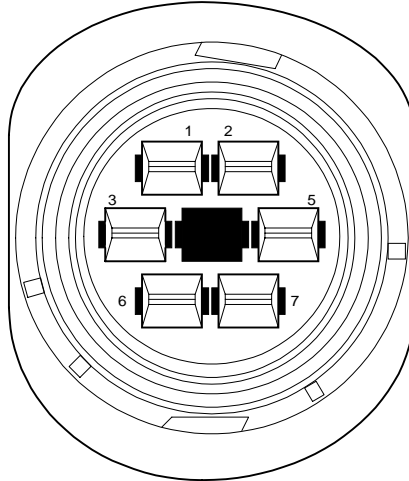

Figure 2-2 Front Panel POWER IN Connector

Table 2-3 Front Panel POWER IN Connector Pin Designations

Pin	Description
1	+27Vdc
2	Ground
3	+27Vdc
4	NC
5	+27Vdc
6	Ground
7	Ground

Table 2-4 Remote Control and Status

Items	Specifications		
RS-485 Physical Layer	Each MCPA shall support an RS-485 multi-drop differential serial asynchronous communications link operation at 9600 baud, 1 bit start, 8 bit data, 1 bit parity, 1 bit stop bit. The host shall terminate the RS-485 differential receive and transmit lines with 120 ohms. Because this communications bus is also shared with other system resources. The MCPA is required to support the following asynchronous packet format communications protocol.		
Asynchronous Packet Protocol	Packet format used for both commands and responses.		
	Byte	Field	Description
	0	Source ID	Address of Source
	1	Destination ID	Address of Destination
	2	CMND/ ECHO	Command/ Echo field
	Each MCPA shall receive but IGNORE any data packet NOT ADDRESSED to itself. The receiver must reset its state machines and ready itself to Receive the start of the next packet if it observes no activity on its RS-485 receive lines in 50 ms.		
Address	The CMND/ ECHO byte is used to send commands from host to MCPA as follows:		
	Byte	Field	Description
	0	Source ID	Address of Source
	1	Destination ID	Address of Destination
			-b(7): 0 -b(4:6): PAS ID -b(0:3): PAU slot ID
	2	CMND	Command Field
	CMND/ ECHO=		
	00H		Report status
	01H-ffH		Reserved
	Response from PAU	MCPA responses always echo the received CMND bytes as an ECHO byte of the response packet.	
Byte		Field	Description
0		Source ID	-b(7): 0 -b(4:6): PAS ID -b(0:3): PAU slot ID
1		Destination ID	Address of Source
2		Report Data	-b0: 1= High VSWR condition/ 0=normal
			-b1: 1=High Temperature condition/ 0=normal
			-b2: 1=Over Power condition/ 0=normal
			-b3: 1=DC fail condition/ 0=normal
			-b4: 1=Loop alarm condition/ 0=normal
			-b5: 1=PAUenable Condition/ 0=normal
			-b6: reserved (0)
-b7: reserved (0)			

Section 3. Operating Instructions

3-1 Introduction

This section contains operating instructions for Powerwave's Booster Amplifier Subrack (BAS) system.

3-2 Initial Start-Up and Operating Procedures

To perform the initial start-up, proceed as follows:

1. Double check to ensure that all input and output cables are properly connected.

CAUTION

Before applying power, make sure that the input and output of the amplifier are properly terminated at 50 ohms. Do not operate the amplifier without a load attached. Refer to Table 1-1 for input power requirements. Excessive input power may damage the MCPA

NOTE

The output coaxial cable between the amplifier and the antenna must be 50 ohm coaxial cable. Use of any other cable will distort the output.

2. Turn on the supply that provides +27 Vdc to the amplifier system.
3. Place the power ON/OFF switch on the amplifier front panel in the "ON" (middle) position.
4. Close the front access door. Tighten the thumbscrews.
5. Ensure that the GAIN CTRL dip switch is set at minimum gain (maximum attenuation). Refer to Section 1, Table 1-1 for the dip switch's truth table.
6. Allow the amplifiers to warm up for at least 5 minutes before taking power readings.
7. Refer to Appendix C for the power setting procedure.

Section 4. Principles of Operation

4-1 Introduction

This section contains a functional description of Powerwave Technologies Inc.'s, Booster Amplifier Subrack (BAS) system. Refer to figure 4-1 for the system's functional block diagram.

4-2 RF Input Signal

The maximum input power for all carrier frequencies to the system should not exceed the limits specified in section 1, table 1-2.

4-3 RF Output Load

The load impedance should be as good as possible (VSWR of 1.5:1 or better) in the working band for good power transfer to the load. If the amplifier is operated into a filter, it will maintain its distortion characteristics outside the signal band even if the VSWR is infinite, provided the reflected power does not exceed one Watt. A parasitic signal of less than one-Watt incident on the output will not cause distortion at a higher level than the normal forward distortion (i.e. -65 dBc).

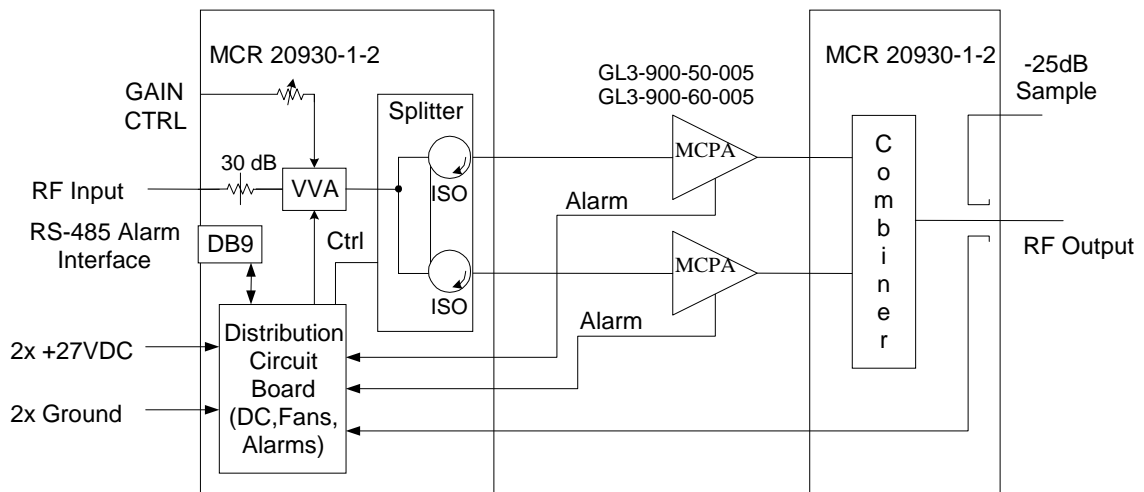

Figure 4-1 System Block Diagram

4-4 System Functional Description

Designed as a subrack for installation in a 2-way transceiver paging base station, the BAS system is comprised of a MCR20930-1-2 Booster Amplifier Subrack (BAS) and two G3L-900-50-005 or G3L-900-60-005 plug-in multi-carrier power amplifiers (MPCAs).

Additionally, the BAS houses a two-way power splitter/combiner and a distribution printed circuit board (PCB). Refer to Appendix A for pinout locations. The RF IN, RF OUT, +27 Vdc and the ALARM summary connector, interface with the host system via front panel cabling.

The RF input signal is split equally and applied to the plug-in amplifiers. The output from each amplifier is an amplified composite signal (refer to table 1-5 for amplifier output specifications). All phase and gain corrections are performed on the signal(s) in the individual amplifier. The amplifier outputs are fed to a power combiner and combined to form a composite RF output (refer to table 1-5). Refer to figure 4-1 for the System Functional Block Diagram.

The distribution printed circuit board (PCB) assembly is used to distribute power to the BAS system's internal components. The PCB circuit is a DC/DC converter designed to convert the +27 Vdc input to +12 Vdc and +15 Vdc. Refer to Appendix B for pinout location.

4-5 Multi-Carrier Power Amplifier (MCPA) Functional Description

The MCPA is a linear, feed-forward multi-carrier power amplifier that operates in the 5 MHz frequency band from 935 MHz to 940 MHz (refer to table 1-5 for amplifier specifications). Each amplifier is a self-contained module and is functionally independent of the other MCPA in the system. The amplifiers are designed for parallel operation to achieve high peak power output (refer to Table 1-2 for MCPA power specifications). Each MCPA has an alarm board that monitors the amplifier performance. If a failure or fault occurs in an MCPA, it is transmitted to the host system via the D-subminiature 21WA4 connector at the rear of the module. A warning light (LED), which is routed from the amplifier via the J7 connector on the PCB to the front panel of the BAS, will illuminate. The indicator LEDs are identified as Alarm 1 and Alarm 2 which corresponds to their respective amplifier..

The amplifier is compliant to the requirements of FCC Part 90 with respect to spurious emissions. Constant gain is maintained by continuously comparing active paths with passive references, and correcting for small variations through the RF feedback controls. All gain variations, for example those due to temperature, are reduced to the passive reference variations. The amplifier is comprised of:

- A preamp
- A driver amplifier
- A main amplifier
- An error and pre-error amplifier
- Alarm monitoring and control

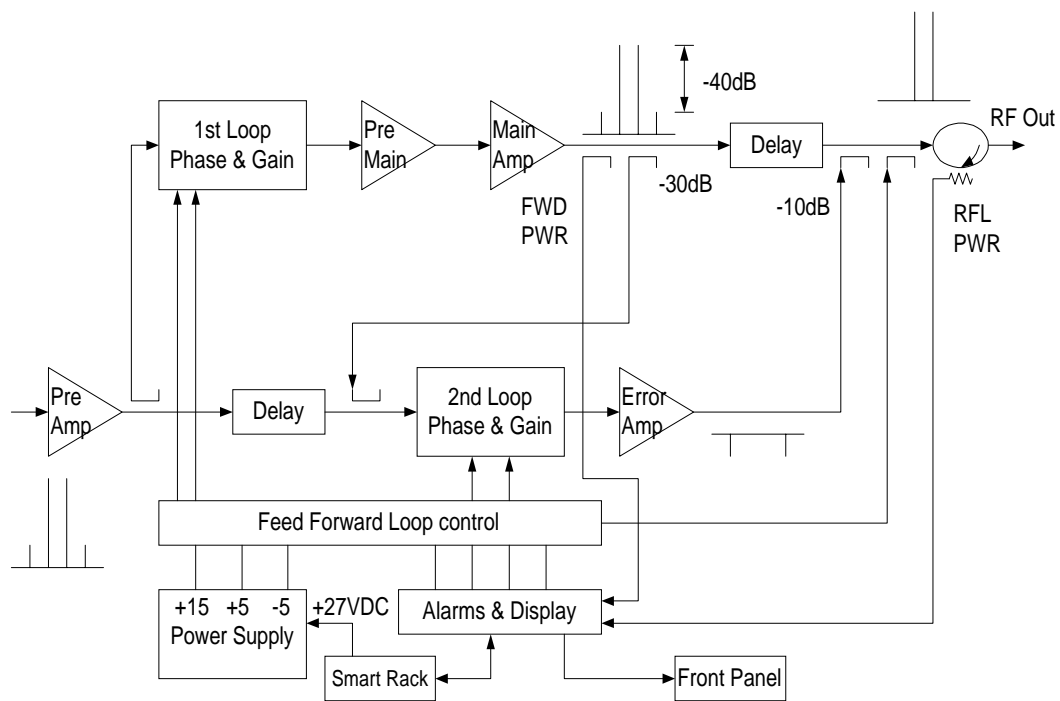

Figure 4-2 Multi-Carrier Power Amplifier Functional Block Diagram

4-5.1 Predriver Amplifier

The input of the amplifier uses two stages of class AB amplification which provide approximately 13.5 dB of gain in the 5 MHz frequency band from 935 MHz to 940 MHz. The amplifier operates on +27 Vdc.

4-5.2 Three-Stage Driver Amplifier

The input of the amplifier uses three stages of class AB amplification which provide approximately 32 dB of gain in the 5 MHz frequency band from 935 MHz to 940 MHz. The amplifier operates on +27 Vdc, and a bias voltage of +5 Vdc. The logic controls the +5 Vdc bias voltage that shuts down the amplifier.

4-5.3 Main Amplifier

The signal provides approximately 11 dB of gain in the 935 to 940 MHz frequency band (refer to table 1-5 for amplifier specifications). The main amplifier operates on +27 Vdc, and a bias voltage of +5 Vdc. The alarm logic controls the +5 Vdc bias voltage that shuts down the amplifier.

The main amplifier employs class AB amplification for maximum efficiency. The error amplifier and feed forward loops are used to correct signal non linearities introduced by the class AB main amplifier. The error amplifier operates in class A mode. The RF input signals are amplified by a preamp and coupled to an attenuator and phase shifter in the first feed-forward loop. The main signal is phase shifted by 180 degrees and amplified in the premain amplifier. The output from the premain amplifier is fed to the class AB main amplifier.

The signal output from the main amplifier is sampled using a coupler, and the sample signal is combined with the main input signal and input to the second feed-forward loop. The error signal is attenuated, phase shifted 180 degrees, then fed to the error amplifier where it is amplified to a level identical to the sample output from the main amplifier. The output from the error amplifier is then coupled back and added to the output from the main amplifier. The control loops continuously make adjustments to cancel out any distortion in the final output signals.

4-5.4 Alarm Monitoring and Control

During routine operation, all normal variations are automatically compensated for by the feed-forward loop control. However, when large variations occur beyond the adjustment range of the loop control, a loop fault will occur. When this happens, the ALARM LED is illuminated on the front panel of the subrack. The fault is transmitted back to an external summary module via the external ALARM interface connection on the front panel of the subrack.

4-5.5 Loop Control Circuit

The primary function of the first loop is to provide an error signal for the second loop. The primary function of the second loop is to amplify the error signal to cancel out spurious products developed in the main amplifier. The input signal is amplified by a preamplifier and fed to a coupler and delay line. The signal from the coupler is fed to the attenuator and phase shifter in the first loop. The first loop control section phase shifts the main input signals by 180 degrees and constantly monitors the output for correct phase and gain.

The second loop control section obtains a sample of the distortion added to the output signals by the main amplifiers. The signal is phase shifted 180 degrees, then fed to the error amplifier where it is amplified to the same power level as the input sample. The signal is then coupled to the error signal on to the main output signal. The final output is monitored by the second loop and adjusted to ensure that the signal distortion and intermodulation distortion (IMD) on the final output is cancelled out.

4-6 Amplifier Module Cooling

Although each amplifier contains its own heat sink, it is cooled by forced air. Two fans mounted on the front of the subrack are used for forced air cooling and redundancy. The fans draw air through the front of the system and exhaust hot air out the back. The fans are field replaceable. Each amplifier, when properly cooled, will provide sufficient cooling to maintain the amplifier within the specified operating temperature range. Six inches of free space are required at both the front and rear panels of the subrack to allow adequate air volume to circulate over the heat sinks.

4-7 Power Distribution

Primary DC power for the amplifier is provided by the host system. The amplifier module has a DC/DC converter and voltage regulator that converts the +27 Vdc to +15 Vdc, +5 Vdc, and +8 Vdc for internal use.

Section 5. Maintenance

5-1 Introduction

This section contains periodic maintenance and performance test procedures for Powerwave's Booster Amplifier Subrack (BAS) system.

NOTE

Check your sales order and equipment warranty before attempting to service or repair the unit. Do not break the seals on equipment under warranty or the warranty will be null and void. Do not return equipment for warranty or repair service until proper shipping instructions are received from the factory.

5-2 Periodic Maintenance

Periodic maintenance requirements are listed in Table 5-1. Table 5-1 also lists the intervals at which the tasks should be performed.

Table 5-1. Periodic Maintenance

Task	Interval	Action
Inspection		
Cables and Connectors	12 Months	Inspect signal and power cables for frayed insulation. Check RF connectors to be sure that they are tight.
Performance Tests	12 Months	Perform annual test per paragraph 5-5.
Clean Fans/Heat Sinks	3 Months	Inspect for debri. Remove dust with a soft cloth/brush or vacuum cleaner.

5-3 Test Equipment Required For Test

Test equipment required to test the amplifier is listed in Table 5-2. Equivalent test equipment may be substituted for any item, keeping in mind that a thermistor type power meter is required.

NOTE

All RF test equipment required must be calibrated to 0.05 dB resolution. *Any deviation from the nominal attenuation must be accounted for and* factored into all output readings.

Table 5-2. Test Equipment Required

Nomenclature	Manufacturer	Model
Signal Generator	H.P.	8656B
20 dB Attenuator, 250 Watt	Bird	Tenuline
20 dB Attenuator, 20 Watt (2 each)	Bird	Tenuline
Spectrum Analyzer	H.P.	8560E
Coax Directional Coupler	H.P.	778D
Power Meter / Sensor	H.P.	437B / 8481A
Arbitrary Waveform Generator	Sony	AWG2021
Network Analyzer	H.P.	8753C
Source Diskette	Powerwave	

5-4 Performance Test

Performance testing should be conducted every 12 months to ensure that the amplifier system meets the operational specifications listed in Table 5-3. Also verify system performance after any amplifier module is replaced in the field. The test equipment required to perform the testing is listed in Table 5-2, and the test setup is shown in Figure 5-1.

NOTE

The frequencies used in this test are typical for an amplifier with a 5 MHz band from 935 MHz to 942 MHz. Select evenly spaced F1, F2, F3, and F4 frequencies that cover the instantaneous bandwidth of your system.

5-4.1 Amplifier Performance Test

To perform this test, proceed as follows:

Connect test equipment as shown in Figure 5-1.

WARNING

Do not apply any RF signals at this time.

5-4.1.1 Amplifier Spurious Emissions Test:

With the RF input signal to the amplifier set to be as shown in Figure 5-1, use the spectrum analyzer to measure the spurious emissions performance. Record test data in Table 5-3. Verify that it is within the specifications shown in Table 1-2. Switch tested amplifier to OFF.

5-4.1.2 Gain Test:

1. Disconnect spectrum analyzer from test setup, and connect the network analyzer.
2. Set network analyzer as follows:
 - A. Power output to -13 dBm.
 - B. Frequency start to 935 MHz.
 - C. Frequency stop to 942 MHz.
 - D. Normalize the network analyzer for gain and return loss.
3. Check the amplifier gain across the band from 935 MHz to 942 MHz. Gain should be as specified in Table 1-2. Record test data in Table 5-3.

5-4.1.3 Input Return Loss:

Read and record the S_{11} return loss measurement on network analyzer. Record test data in Table 5-3.

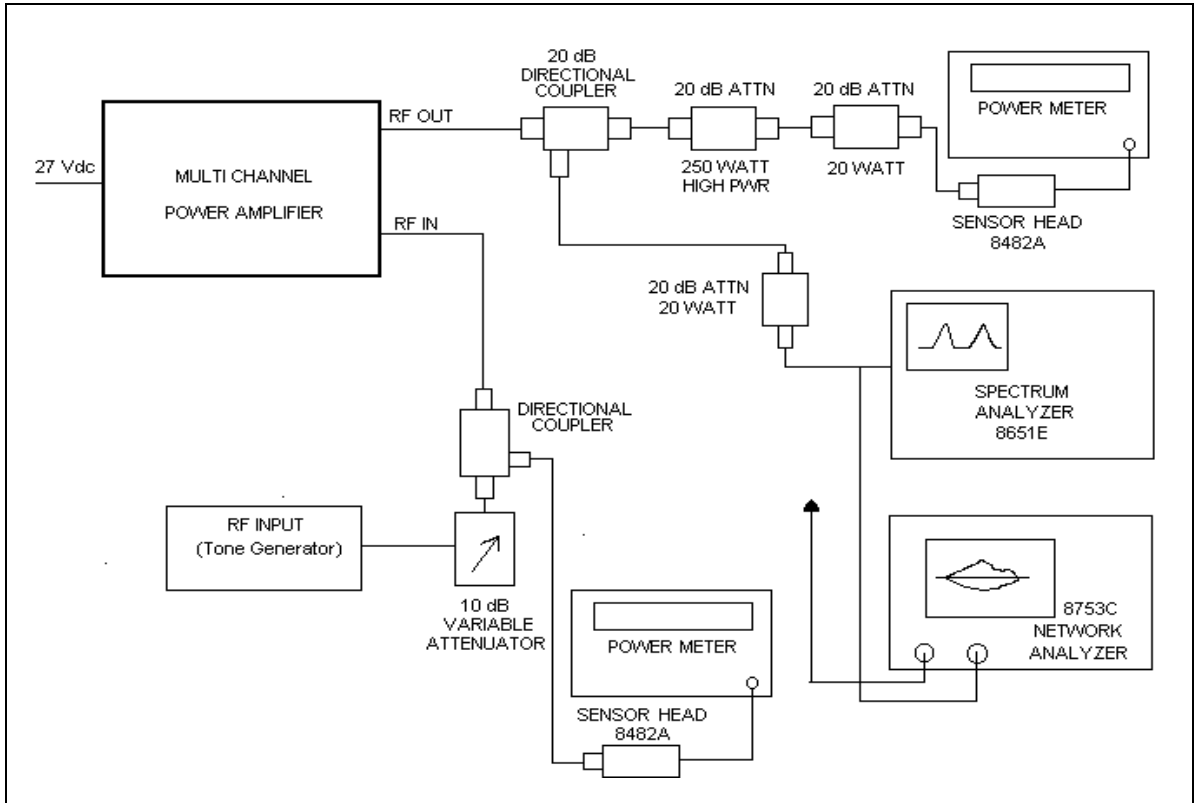

Figure 5-1 Amplifier Test Setup Diagram

Table 5-3. Multi-Carrier Power Amplifier Test Data Sheet

DATE _____

MODULE S/N _____

TEST CONDITIONS:

Load and Source Impedance: 50 Ohms

VSWR: < 1.2:1

Supply Voltage: +27 Vdc ±0.1 Vdc

TEST	SPECIFICATION	MIN	MAX	DATA
RF Gain	Vcc = 27 Vdc PO = 50 W Freq. = 935 - 942 MHz	Table 1-2 -0.5 dB	Table 1-2 +0.5 dB	
Spurious Emissions	Vcc = 27 Vdc PO = 50 W 935 - 942 MHz Band		-65 dBc	
Gain Flatness	Vcc = 27 Vdc PO = 50 W 935 - 942 MHz Band		±0.5 dB	
Input Return Loss	Vcc = 27 Vdc PO = 50 W 935 - 942 MHz Band	-12 dB		

PASS _____ FAIL _____

Tested by _____

5-5 Field Replacement of the Module

The G3L-900-50-005 and GL3-900-60-005 multi-carrier power amplifier module can be replaced in the field on site by a qualified technician with experience maintaining RF power amplifiers and similar equipment:

To replace a power amplifier module, proceed as follows:

1. Set on/off switch on the front panel of the amplifier module to OFF (down).
- 2.
3. Loosen two thumbscrews that secure amplifier module to subrack.

CAUTION

When removing the amplifier from the subrack, it is very important to support the amplifier such that the rear of the module does not suddenly drop when the guide rail disengages from the track. A drop such as this could damage the rear 21WA4 multipin connector.

4. With steady even pressure, use handle on front of amplifier to pull module out of subrack.
5. Install replacement in reverse order of steps 1 through 3 above.

Section 6. Troubleshooting

6-1 Introduction

This section contains a list of problems which users have encountered and a few suggested actions that may correct the problem. If the suggested corrective action does not eliminate the problem, please contact your Powerwave field representative or the factory for further instructions.

NOTE

Check your sales order and equipment warranty before attempting to service or repair the unit. Do not break the seals on equipment under warranty or the warranty will be null and void. Do not return equipment for warranty or repair service until proper shipping instructions are received from the factory.

6-2 Troubleshooting

Refer to Table 6-1 for troubleshooting suggestions.

Table 6-1. Troubleshooting.

Symptom	Suggested Action
Inoperative	<ol style="list-style-type: none"> 1. Check for proper power supply voltages. 2. Verify all RF connections. 3. Contact your field representative.
MCR20930-1-2 Fan Noise	<ol style="list-style-type: none"> 1. Locate noisy fan. 2. Check for damage 3. Replace noisy or damaged fan
G3L-900-50-005 or GL3-900-60-005 Inoperative	<ol style="list-style-type: none"> 1. Check for proper power supply voltage. 2. Verify all RF connections. 3. Verify that unit does not have a major fault (red LED on front panel). Recycle power.

6-3 Return For Service Procedures

When returning products to Powerwave, the following procedures will ensure optimum response.

6-3.1 Obtaining An RMA

A Return Material Authorization (RMA) number must be obtained prior to returning equipment to the factory for service. Please contact our Repair Department at (949) 809-1100 to obtain this number, or FAX your request to (949) 757-6676. Failure to obtain this RMA number may result in delays in receiving repair service.

6-3.2 Repackaging For Shipment

To ensure safe shipment of the amplifier, it is recommended that the package designed for the amplifier be used. The original packaging material is reusable. If it is not available, contact Powerwave's Customer Service Department for packing materials and information.

Appendix A. Booster Amplifier Subrack Backplane Wiring Diagram

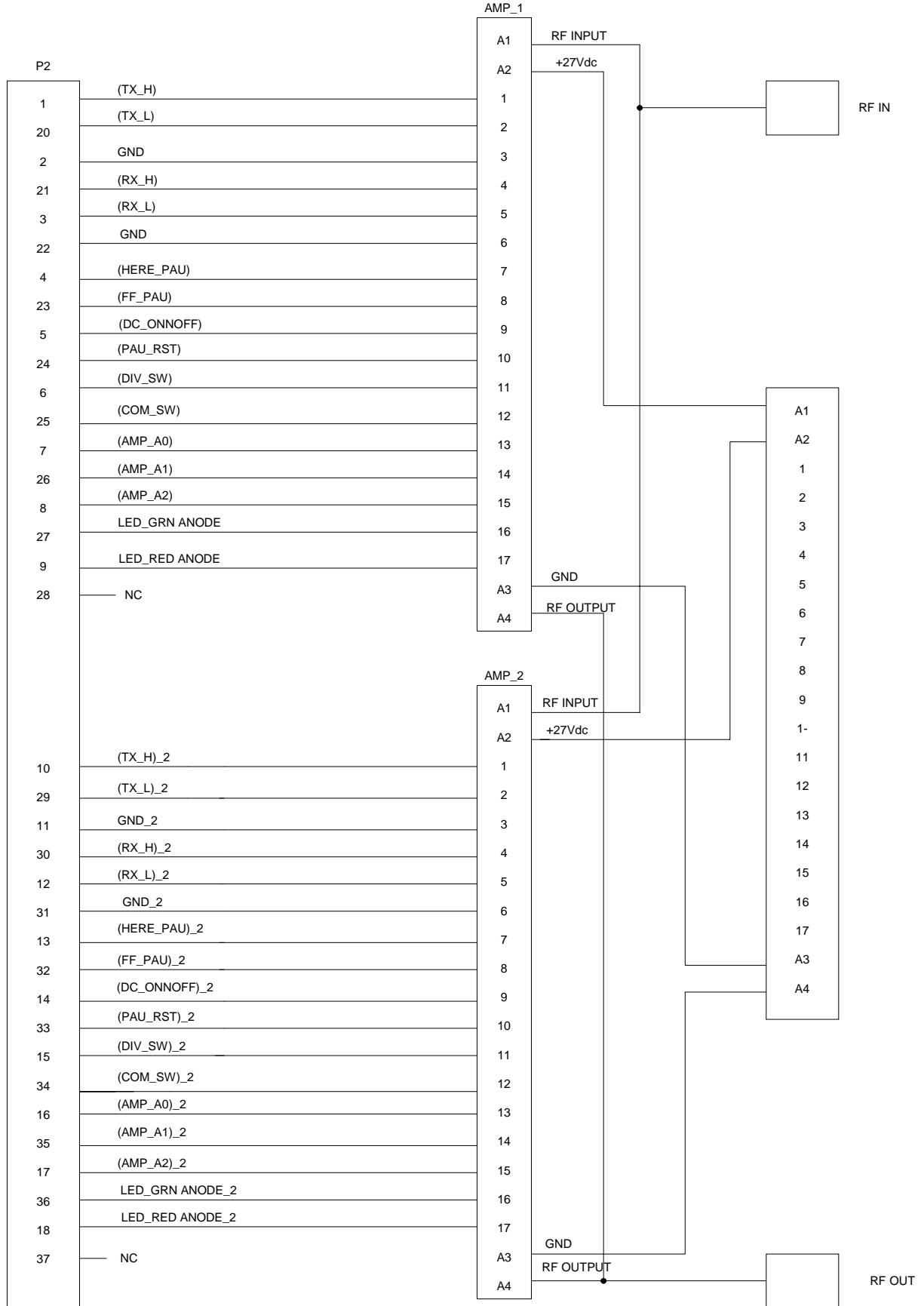

Appendix B. Distribution Printed Circuit Board Pinout Location

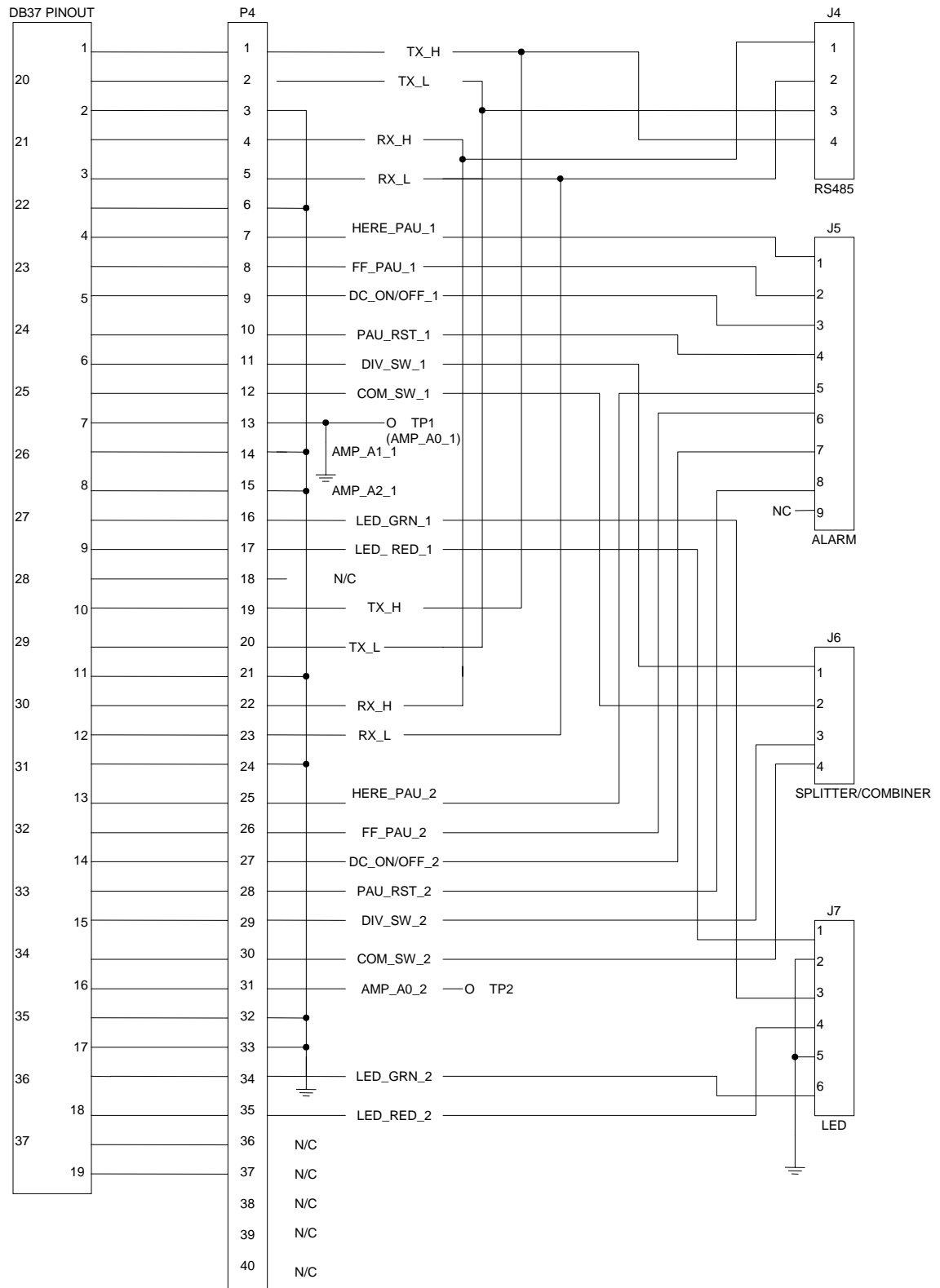

Appendix C Power Setting Procedure

C-1 Power Setting Calculations:

1. Ensure the composite input power to the Powerwave MCR20930-1-2 is < 0 dBm.
2. Determine the required output level at the hatch plate per carrier (Analog, Digital, CDPD, and Setup Channels). Follow the example after step 5 below.
3. Determine the amount of loss between the subrack output and the hatch plate.
 - A. Either the calculated value (Lucent uses 1.7dB for the Series II), or
 - B. Measure the loss
 1. Key one radio and make a measurement in dBm at the front of the subrack with an HP EPM-441A or equivalent power meter. Write the value down: _____ dBm.
 2. Disconnect the radio and move the power meter to the hatch plate.
 3. Key the same radio and make a measurement in dBm, and write it down: _____ dBm. The difference between the two measurements is the loss.
4. Determine the amount of power output at the rear of the subrack per carrier.
5. Multiply the number of carriers times the output power level per carrier at the front of the subrack. Three blank tables are provided on page 3 of this appendix for you to record your desired power levels.

	A	B	C	D	E	F	G
	Hatch Power (w)	Convert Hatch Power to dBm	Loss from Hatch to Powerwave Subrack (dB)	Power @ Powerwave Subrack (dBm)	Convert Powerwave Subrack Power to watts	No. of Carriers	Total Power per Signal (watts)
Formula	a	$b=10*\text{LOG}(a / 0.001)$	c	$d=b+c$	$e=x^{10}(d/10)*0.001$	f	$g=ef$
Example							
Analog	6.3	$10*\text{Log}(6.3/0.001)=37.9934$	1.7	$37.9934 + 1.7 = 39.6934$	$x^{10}(39.9934/10)*0.001=9.3184$	10	93.1838
CDMA*	21*	$10*\text{Log}(21/0.001)=43.2222$	1.7	$43.2222 + 1.7 = 44.9222$	$x^{10}(44.9222/10)*0.001=31.0613$	2	62.1226
CDPD	6.3	$10*\text{Log}(6.3/0.001)=37.9934$	1.7	$37.9934 + 1.7 = 39.6934$	$x^{10}(39.9934/10)*0.001=9.3184$	1	9.3184
Setup	6.3	$10*\text{Log}(6.3/0.001)=37.9934$	1.7	$37.9934 + 1.7 = 39.6934$	$x^{10}(39.9934/10)*0.001=9.3184$	1	9.3184
Inner Tier	2.5	$10*\text{Log}(2.5/0.001)=33.9794$	1.7	$33.9794 + 1.7 = 35.6794$	$x^{10}(35.6794/10)*0.001=3.6978$	4	14.7911
						Total Power	188.7342

*Some RF Engineers will give the power for Pilot Page and Sync (on the order of 2 to 5W). Powerwave normally multiplies this value by 7 for the purpose of roughly calculating the CDMA channel with full traffic load.

If the total output power level at the front of the Powerwave subrack exceeds the subrack's specified capability with the number of populated amplifiers: Reduce the number of input radios until the subrack power rating is met.

C-2 Power Setting Procedure:

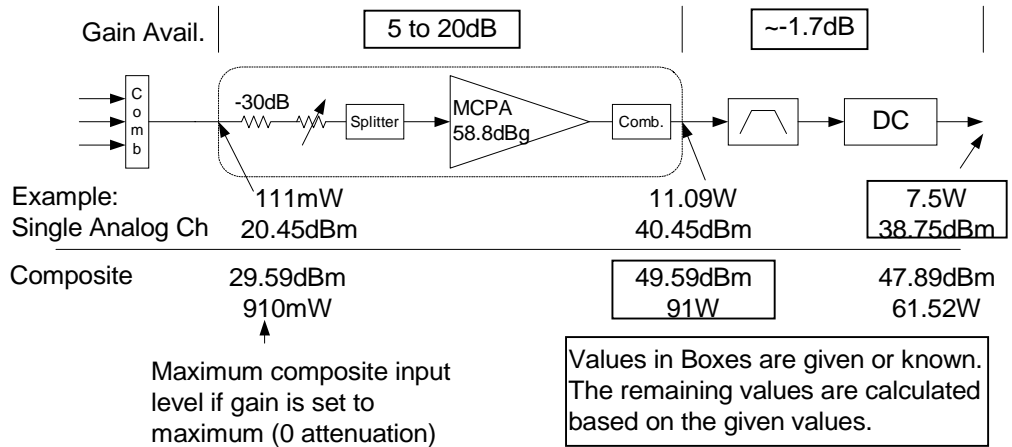

Figure C-1 Gain Block Example

1. Set all transceiver levels to midrange output levels if this is a new base station installation. For existing base stations, the levels may be left as they currently are set.

NOTE

The composite input level should not exceed -20dBm most applicatons. Higher input levels may result in over-driving the MCR20930-1-2 amplifier subrack. Refer to section 1 for individual model power specifications.

2. Ensure all radios are not transmitting, including CDPD.
3. Connect the power meter, with appropriate attenuators as necessary, to the transmit filter output feed at the hatch plate.
4. Set the GAIN CTRL to minimum gain (maximum attenuation). Refer to section 1, table 1-1 for the dip switch truth table.
5. Key one radio (usually this is the primary setup channel).
6. Set the output level using the GAIN CTRL on the Powerwave subrack and transmitter gain adjustment for this single channel. Normally, the CDMA channel has the most limiting range, so this is the best channel to start with, although most technicians normally start with the setup channel. Try to keep the adjustments in the middle of the available range adjustments.
7. Verify the power level is still correct.
8. Unkey the radio.
9. Key one radio at a time and set the power level of each individual radio at the hatch plate according to the calculations made in the first section above. *Do not readjust the GAIN CTRL level.*
10. Unkey all radios.

C-2.1 Overpower Verification

11. Connect the power meter, with appropriate attenuators as necessary, to the RF output of the Powerwave subrack.
12. Reconnect the transmit filter output cable to the antenna.

13. Key all the radios and measure the total maximum power. This power level should not exceed the rating for the MCR20930-1-2. ***If the power rating for the MCR20930-1-2 is exceeded, the intermodulation distortion performance of the amplifiers will suffer and the software-overpower protection feature of the MCR20930-1 will activate.***

NOTE:

Each amplifier will go into overdrive alarm when they are being driven 3 dB over the rated power for that amplifier.

Each amplifier will shut down at 3 dB over the rated power, and possibly cause the entire sector to be disabled.

Table C-1 Amplifier and Amplifier Subrack ratings

Amplifier	1 Module	2 Modules
GL3-900-50-005 +47 dBm (50 Watts) nominal, 60 Watts (max.)	43.5 W (46.39 dBm) nominal	75.8 W (48.80 dBm) nominal, 100 W (max)
GL3-900-60-005 +47.8 dBm (60 Watts) nominal, 75 Watts (max.)	52.3 W (47.18 dBm) nominal	91 W (49.59 dBm) nominal, 120 W (max)

All measurements should be made with a calibrated power meter accurate within $\pm 2\%$ (HP EPM-441A or equivalent)

14. Disconnect all the radios.
15. Reconnect the RF output coax cable to the Powerwave subrack.

	Hatch Power (w)	Convert Hatch Power to dBm	Loss from Hatch to Powerwave Subrack (dB)	Power @ Powerwave Subrack (dBm)	Convert Powerwave Subrack Power to watts	No. of Carriers	Total Power per Signal (watts)
Formula	a	$b=10*\text{LOG}(a / 0.001)$	c	$d=b+c$	$e=x^{10}(d/10)*0.001$	f	$g=ef$
Sector:							
							Total Power

	Hatch Power (w)	Convert Hatch Power to dBm	Loss from Hatch to Powerwave Subrack (dB)	Power @ Powerwave Subrack (dBm)	Convert Powerwave Subrack Power to watts	No. of Carriers	Total Power per Signal (watts)
Formula	a	$b=10*\text{LOG}(a / 0.001)$	c	$d=b+c$	$e=x^{10}(d/10)*0.001$	f	$g=ef$
Sector:							
							Total Power

	Hatch Power (w)	Convert Hatch Power to dBm	Loss from Hatch to Powerwave Subrack (dB)	Power @ Powerwave Subrack (dBm)	Convert Powerwave Subrack Power to watts	No. of Carriers	Total Power per Signal (watts)
Formula	a	$b=10*\text{LOG}(a / 0.001)$	c	$d=b+c$	$e=x^{10}(d/10)*0.001$	f	$g=ef$
Sector:							
							Total Power