

# Operation Manual

**Powerwave**<sup>®</sup>  
technologies

**THE POWER IN WIRELESS™**

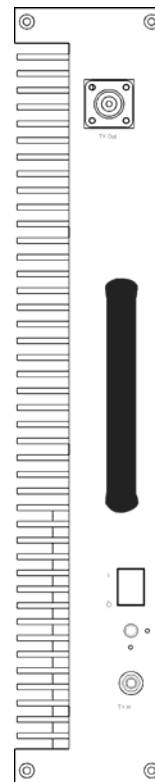

***G3L-2100-30-B (DC) / G3L-2100-30-C (AC)***  
***Wideband Multi-Carrier Power Amplifier***  
***Operation Manual***  
***2110 MHz – 2170 MHz***



© 2003 Powerwave Technologies Incorporated. All rights reserved.

Powerwave Technologies, and the Powerwave logo are registered trademarks

Powerwave Technologies, Inc. reserves the right to make changes to the documentation and equipment, including but not limited to component substitution and circuitry changes. Changes that impact this manual may subsequently be incorporated in a later revision of this manual.

**March 2003**

**Powerwave Technologies, Inc.  
1801 E. St. Andrew Place  
Santa Ana, CA 92705**

**Tel: (714) 466-1000  
(888) 797-9283  
Fax: (714) 466-5800**

**Web Site: [www.powerwave.com](http://www.powerwave.com)**

# **Section 1 General Description**

## **1-1 Introduction**

This manual contains information and procedures for the operation of the model G3L-2100-30-B and G3L-2100-30-C Wideband (WCDMA) Multi-Carrier Power Amplifier (MCPA). The manual is organized into the following sections and appendix.

Section 1	General Description
Section 2	Operation
Appendix A	Specifications

## **1-2 General Description**

The amplifiers are wideband, linear, feed-forward power amplifiers (WPAs) that operate in the 60 MHz frequency bandwidth from 2110 to 2170 MHz with an instantaneous bandwidth of 20 MHz. The amplifier provides linear amplification for single or multi-carrier WCDMA signals. The amplifiers communicate with the base station via a TLCI control interface bus; passing alarm and measurement information to the base station and receiving control information from the base station.

## **1-3 Hardware Interface**

There are three groups of interface connections located on the amplifier chassis. These are RF, power, and control interface (TLCI bus) as described in the paragraphs that follow.

### **1-3.1 RF**

The RF interface is located on the power amplifier front panel consists of the RF-In (TX-In) and RF-Out (TX-Out) connectors as shown in Figure 1-1.

### **1-3.2 Power Supply**

Power supply voltages (-48 VDC or 230 VAC) from the base station subrack are connected to the amplifier via connector X3, pins A – D located on the power amplifier rear panel as shown in figure 1-1. Table 1-1 lists the voltages and descriptions for each pin.

**Table 1-1 Primary Power Connections**

<b>Signal Group</b>	<b>X3 Connector Pin</b>	<b>Signal Name</b>	<b>Description</b>
DC	D	-48VDC	DC Minus (isolated from amplifier chassis)
	E	+48VDC	DC Plus (isolated from amplifier chassis)
AC	A	L	AC Phase (isolated from amplifier chassis)
	B	N	AC Zero (isolated from amplifier chassis)
	C	PE	AC Protective Ground (connected to chassis)

### 1-3.3 TLCI Bus Communications

The purpose of the TLCI bus is to provide a communications interface between the power amplifier and base station. The bus is connected from the base station subrack to the X3 connector located on the power amplifier rear panel as shown in figure 1-1. Table 1-2 lists the signal names and descriptions for each pin of the 24-pin connector.

**Table 1-2 TLCI Bus Connections**

Signal Group	X3 Connector Pin	Signal Name	Description
TLCI	2	AXMTP	Ethernet, 10BASE-T
	3	AXMTN	
	18	ARCVP	
	19	ARCVN	
WPA ID	5	WPA_ID_BIT0	Hard-coded WPA ID
	13	WPA_ID_BIT1	BIT0=LSB, BIT!=MSB
	21	WPA_ID_BIT2	OPEN=1=Logical High Gnd=0=Logical Low
GND	1	Ground	Connected to WPA chassis ground
	4		
	8		
	9		
	10		
	11		
	12		
	17		
	20		
	24		
Free	6, 7, 14, 15, 16, 22, 23		Reserved for WPA manufacture

## 1-4 Alarms

The WPA generates the following alarms and communicates them to the base station via the TLIC bus:

- VSWR
- Gain
- Temperature
- Over-Drive
- Power Supply
- Linearization

The base station is able to query the current alarm status from the WPA. Fault status is cleared at unit reset which means that any alarm detected after reset is reported to the base station. The alarm status always represents existing conditions.

### 1-4.1 VSWR

The WPA supervises the output (load) VSWR and gives the alarm based on the following limits as listed in table 1-3.

**Table 1-3 VSWR Alarm Limits**

<b>VSWR Alarm Status</b>	<b>Limits</b>
VSWR alarm ON	VSWR at the output > 8.5:1 @ phase 0-360°
VSWR alarm OFF	VSWR at the output < 3.0:1 or when the VSWR alarm is disabled @ phase 0-360°

### 1-4.2 Gain

The WPA supervises the gain of the unit and gives the gain alarm according to the limits listed in table 1-4.

**Table 1-4 Gain Alarm Limits**

<b>Gain Alarm Status</b>	<b>Limits</b>
Gain alarm ON	Gain deviates more than $\pm 1.5$ dB from specified nominal gain or if the carrier cancellation loop is out of lock, the gain alarm is activated
Gain alarm OFF	Gain is within the specified range or disabled

### 1-4.3 Temperature

The WPA monitors the internal temperature. The measured temperature must represent the base plate temperature of the main power amplifier. The alarm is given according to the limits listed in table 1-5.

**Table 1-5 Temperature Alarm Limits**

Temperature Alarm Status	Limits
Temperature alarm ON	Internal base plate temperature is equal or higher than 92°C
Temperature alarm OFF	Internal base plate temperature decreases more than 10°C from the alarm on temperature

#### 1-4.4 Overdrive

The overdrive alarm causes an automatic WPA shutdown.

#### 1-4.5 Power Supply

The WPA monitors the internal DC supply voltages and gives the power supply alarm if any of the voltages are out of the specified range. This alarm causes an automatic WPA shutdown.

#### 1-4.6 Linearization

In case of poor output signal, the linearization causes an automatic WPA shutdown.

### 1-5 Status Indicator

The status indicator LED is located on the WPA front panel as shown in figure 1-1. The LED has tri-color capability: red, yellow, and green. The LED's blinking frequency is 0.5 – 1 Hz with a duty cycle of 45 – 55%. The LED indicates the status of the WPA as listed in table 1-6.

**Table 1-6 Status Indicator Colors**

LED Color	WPA Status
Red (stable)	Manual main-switch turned standby and no TCP/UDP connection established
Red (stable) LED lighting period 1.5±0.5 sec	Manual main-switch turned ON or WPA is resetting
Yellow (blinking)	WPA in self-heating state
Yellow (stable)	In startup phase, WPA is in standby state and before state change message from WPA
LED state as it was before disconnection	TCP/IP connection is lost for two minutes
Yellow (stable)	TCP/IP connection is lost and WPA is in standby state

## **1-6 Functional And Physical Specifications**

Functional and physical specifications for the model G3L-2100-30-B and G3L-2100-30-C amplifiers are listed in appendix A.

## **1-7 Equipment Changes**

Powerwave Technologies, Inc. reserves the right to make minor changes to the equipment, including but not necessarily limited to component substitution and circuitry changes. Changes that impact this manual may subsequently be incorporated in a later revision of this manual. To that end, we ask that you, our customer, share with us any information acquired in field situations that would enhance this manual.

## **1-8 Ordering Information**

Table 1-7 below gives the model numbers and descriptions used when ordering major components.

**Table 1-7 Major Components**

Nokia Model Number*	PWAV Model Number*	Manual Number	Description
WPAA	G3L-2100-30-B	044-05133	30W, 2110 – 2170 MHz amplifier module (DC)
WPAB	G3L-2100-30-C	044-05133	30W, 2110 – 2170 MHz amplifier module (AC)

\* Nokia model number located on front panel. Powerwave Technologies model number located on rear panel.

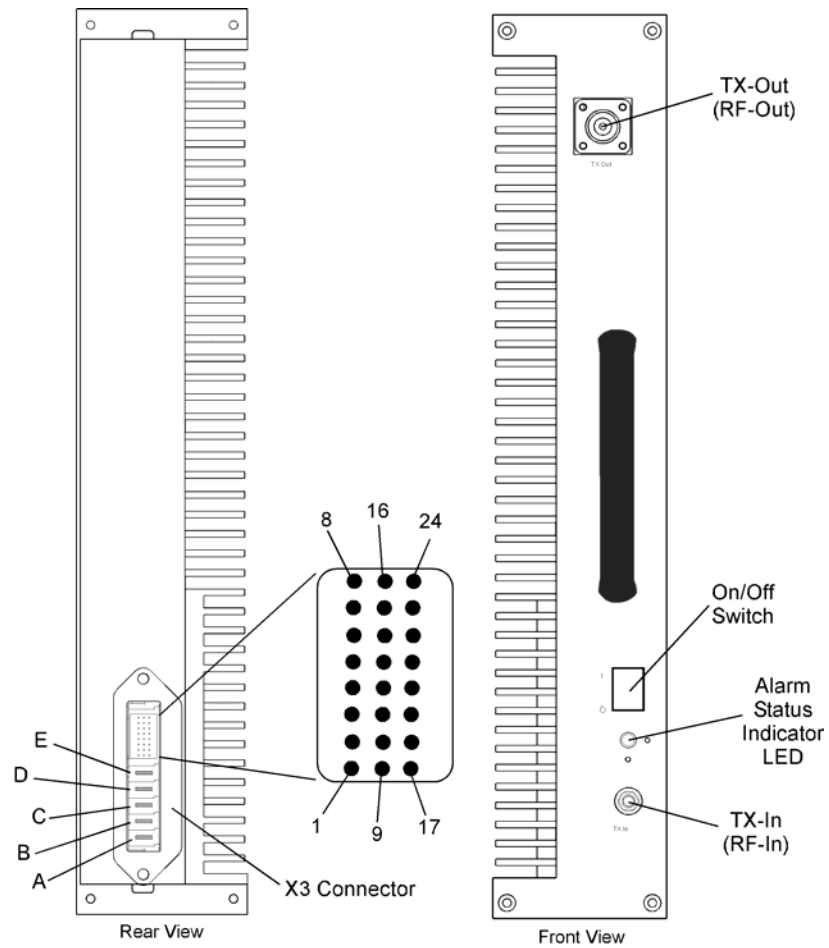

Figure 1-1 G3L-2100-30-B and G3L-2100-30-C Front and Rear Views



## Section 2 Operation

### 2-1 Introduction

This section contains operating instructions for the G3L-2100-30-B or G3L-2100-30-C wideband power amplifier (WPA).

### 2-2 Initial Start-Up and Operating Procedures

The manual main power supply ON/OFF switch is located on the WPA front panel (refer to figure 1-1 and paragraph 1-5 for status indicator conditions). Turn on the WPA as described in the steps that follow.

#### **CAUTION**

*Before applying power, make sure that the input and output of the system is properly terminated at 50 ohms. Do not operate the system without a load attached. Refer to appendix A for input power requirements. Excessive input power may damage the amplifier.*

#### **WARNING**

*Never remove or install coaxial cables on either the subrack input or output port when the power amplifier is turned on. Operating the power amplifier while disconnecting and connecting RF cables may damage the equipment and/or cause personal injury.*

1. Verify that all input and output RF cables are properly connected. Do not apply an RF signal to the WPA.
2. Turn on the main manual power supply switch (1=ON, 0=OFF). The WPA will self-test and initialize (<15 sec), then establish communication with the base station via the TLCI bus. When completed, the WPA notifies the base station that it is ready to be taken into operation. The WPA then remains in a standby state until commanded by the base station. The command received from the base station includes the operating band and based on that band, the pilot frequency sets to 10 MHz lower than the lowest carrier in the operating band.

#### **NOTE**

*When the WPA is switched on in temperature conditions below the minimum operating temperature (-10°C), self-heating is performed until an acceptable operating temperature exists.*

#### **NOTE**

*The main manual power supply switch is also used to reset the WPA by manually setting the switch to OFF then back to ON.*

# Appendix A. Specifications

**Table A-1 G3L-2100-30-B/30-C Wideband Multicarrier Cellular Amplifier Functional Specifications**

Frequency Range	2110 - 2170 MHz (60 MHz Bandwidth)
Instantaneous Bandwidth	20 MHz *
Total Typical / Maximum Input Power	-15.7 - +4.8 / +5.8 dBm
Total Output Power	30 W (44.8 dBm)
Adjacent Channel Leakage Power Ratio (ACLR) Spectrum Analyzer settings: 30 KHz RBW, 300 KHz VBW, True RMS detector	ACLR1 <-46dBc@f=fc ±5 MHz ACLR2 <-51dBc@f=fc ±10 MHz
RF Gain	40 dB ±0.5 dB
Gain Flatness:	±0.5 dB
Output Protection:	Mismatch Protected
Input Port Return Loss:	18 dB min
Harmonics:	Better than -50 dBc
Out of Band Spurious:	Better than -60 dBc
Duty Cycle:	Continuous
DC Input Power: G3L-2100-30-B	-48 Vdc nominal, 6.5 amps typical (15 amps max) Operational -57 Vdc to -60 Vdc (Po derated outside normal operating range)
AC Input Power: G3L-2100-30-C	230 Vac nominal, 50/60 Hz, 1.9 amps typical (3 amps max) Operational 264 Vac to 300 Vac (Po derated outside normal operating range)
Operating Temperature:	-10 °C to +50 °C
Storage Temperature:	-40 °C to +85 °C
Operating Humidity:	0 % to 80 % Relative Humidity (noncondensing)
Storage Humidity:	0 % to 100 % Relative Humidity (noncondensing)
AC, DC Input, Summary Alarm, Base Station Communication TLCI Bus:	Elcon Modular Flatpaq™
RF Input Connector:	SMA Female
RF Output Connector:	Type N-Female
Power Consumption:	DC Version: 310 Watts @ P <sub>o</sub> = 30 W average power AC Version: 325 Watts @ P <sub>o</sub> = 30 W average power
Weight:	28 lbs.
Dimensions:	3.125" High, 16.75" Wide, 14.125" Deep, 15.75" Deep including connector guides

\* The command received from the base station includes the operating band and based on that band, the pilot frequency sets to 10 MHz lower than the lowest carrier in the operating band.