

5. IP Over Fiber

IP (Internet Protocol) network is the latest Powerwave network type with UDP/IP protocol and many features, such as wire or fiber connection, PPP, routing capabilities for many sub networks, etc.

IP network communication includes communication between network nodes as well as communication between gateway nodes, for instance FON units, and an O&M software.

Communication can be initiated either by an O&M software or a network node.

When initiated by an O&M software, an operator connects to the network and logs on to the desired node. An OMS station can also initiate scheduled communication that automatically connects to the network and logs on to a node.

A network node initiates communication when an alarm is to be transferred, normally to an OMS station. It also initiates communication if callback is required in a logon session.

All operation and maintenance of repeaters and remote hubs are carried out via an O&M software connected to a network. There are two network types that can be used for this purpose, IP network and R2R network.

This chapter describes IP networks only and is focused on fiber networks.

IP networks over wire and R2R networks are described in the VM100 01/EN, *OM-Online, User's Manual*. This manual also contains further information about IP networks, IP address planning, and network configuration.

This chapter is divided into the following main parts:

- Terminology for IP networks, page [5-2](#).
- Hardware and software requirements for IP networks, page [5-3](#).
- Fiber optic network characteristics, page [5-4](#).
- Node units in IP networks, page [5-5](#).
- Net interfaces of the FON unit, page [5-6](#).
- An example of a network, page [5-7](#).

IP Network Terminology

In the descriptions of the IP network the terminology in the following table is used.

Network type	IP	
Protocol	IP	
Network name	W-net	F-net
Link name	W-link	F-link
Link media	Wire	Fiber
Link interface	WLI	FLI

Abbreviations

IP	Internet Protocol.
W-net	Wire network.
F-net	Fiber network.
W-link	Wire link.
F-link	Fiber link.
WLI	Wire Link Interface.
FLI	Fiber Link Interface.

Other abbreviations used in this manual are found in the [Abbreviations](#) section in the beginning of this manual.

Net and Link

The following two figures show what a net means and what a link means in this manual.

Figure 5-1 shows a W-net or F-net with WLI or FLI interface respectively.

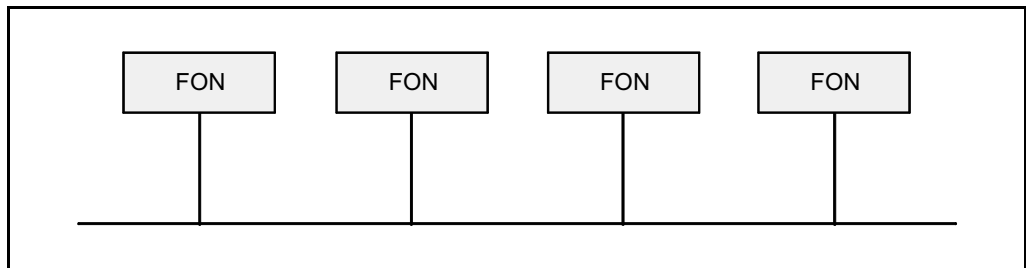

Figure 5-1. W-net or F-net

Figure 5-2 shows a W-link or F-link with WLI or FLI interface respectively.

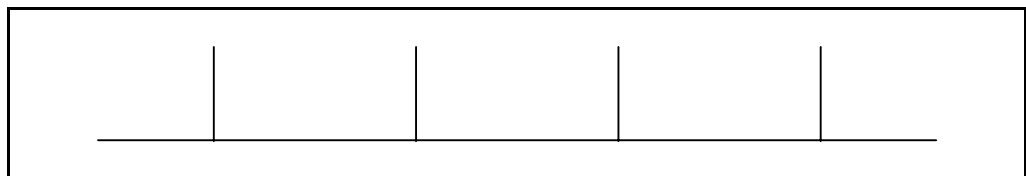

Figure 5-2. W-link or F-link

Requirements

To be able to use an IP network, the FON hardware and software stated below is required. Hardware and software that does not meet the requirements below can be upgraded.

FON hardware

FON board K129.

FON software

FON SA102 05/1 version R1A or higher.

O&M software versions

An OM-Online, OMT32, or OMS station intended to be used on an IP network requires the following software versions:

OM-Online SA102 60/1 version R1A or higher.

OMT32 SA102 51/3 version R2A or higher.

OMS SA102 54/1 version R2A or higher.

F-Net Characteristics

The IP communication signal in an F-net is modulated on a sub carrier below the RF modulated signal.

The communication transfer rate is 66Kb per second.

F-net can be built up with separate downlink and uplink fibers, multi-drop link communication, and a dedicated master node and slave nodes (M and S respectively in the left figure).

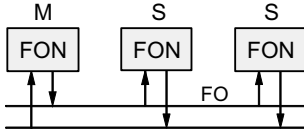

F-net can also be built up with single fiber and full-duplex transmission, see Figure 5-3.

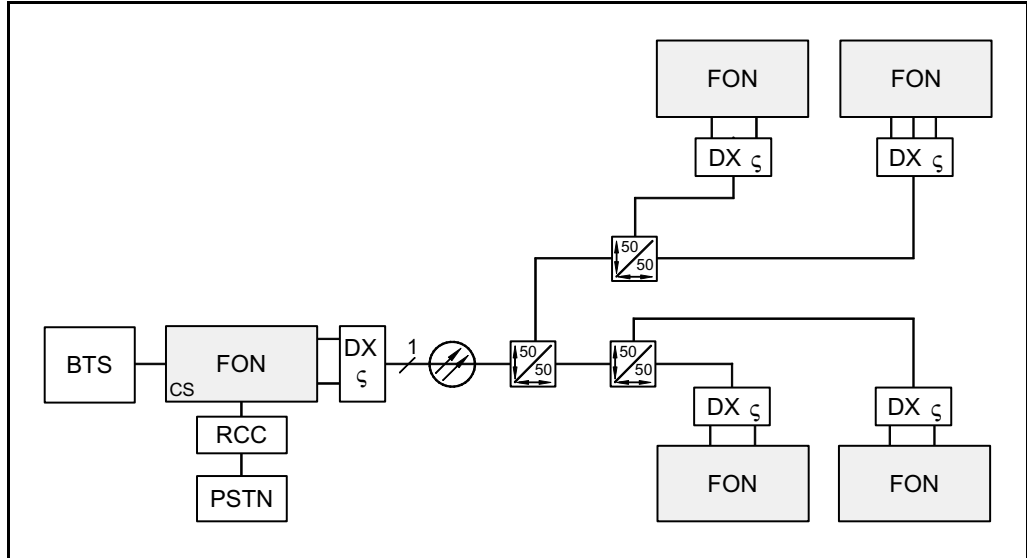

Figure 5-3. Single fiber network with five nodes

The network shown in Figure 5-3 has optical WDMs (DX ̷) in each node, which makes it possible to use one downlink wavelength and four different uplink wavelengths in the same fiber.

An F-net contains one master node (the left FON unit in Figure 5-3) and it can contain up to approximately four slave nodes (the right FON units) due to the signal power sharing in the optical splitters. In Figure 5-3 there are three 50/50 percent splitters that reduce the signal power to each of the four slave nodes to 25% of the initial signal power.

In Figure 5-3, the master node is a gateway by means of an RCC. It can communicate with an O&M software via modem.

The left FON node (CS) only shall be configured with *Control Station Capability* and thus be the master unit. None of the other FON nodes are allowed to have the *Control Station Capability* because it is a master/slave network. Only one node is allowed to speak at the same time.

Control Station Capability is described in the VM100 01/EN, *OM-Online, User's Manual*.

Node Units

This section describes an example of node units used for communication between an O&M software and the nodes in a network.

A PC workstation loaded with the O&M software and configured with a modem can be connected to all nodes that have an RCC (or RCU) and communicate with other units in connected W-nets and F-nets.

Figure 5-4 shows an O&M workstation connected to an F-net, which is also connected to two W-nets.

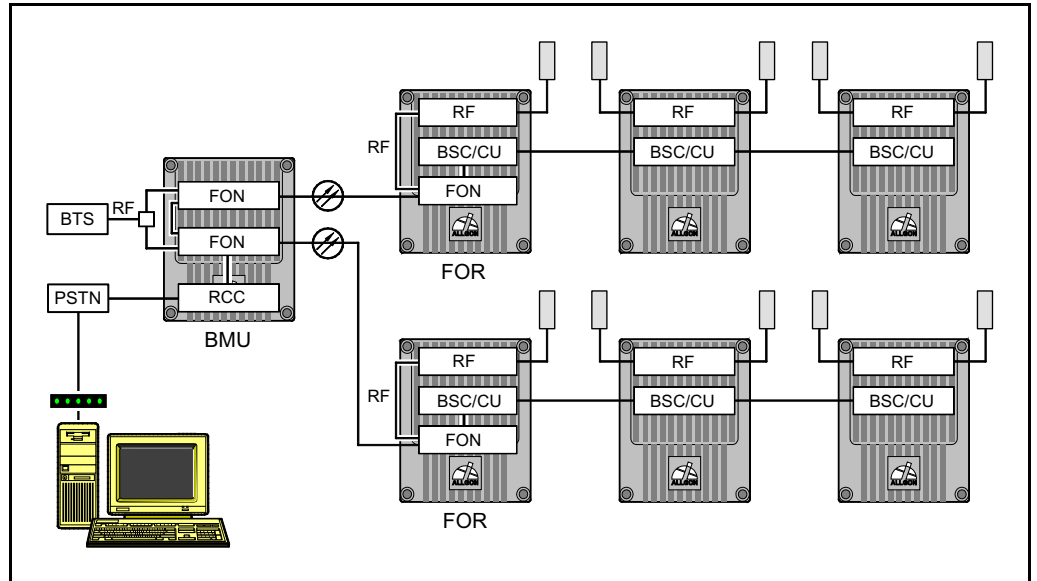

Figure 5-4. O&M workstation connected to an F/W-net

The fibers between the BMU and the FOR units are used for both RF transmission and network communication.

An internal backbone W-net in the BMU interconnects the FON units.

The two FOR units are also included in two W-nets together with two additional repeaters in each of these W-nets.

The O&M workstation in Figure 5-4 can communicate with any of the seven units (one BMU and six repeaters) included in the F-nets and W-nets.

The FON Unit Net Interfaces

This section describes the FON unit in networks, one of the most important subunits in repeater networks. The FON unit is here described as a block with network interfaces.

The FON board contains all software and protocols required for both W-net and F-net communication, routing included. A sole FON board can be a complete node in an F-net or W-net.

Figure 5-5 shows the FON board with the communication interfaces pointed out. The figure shows also some of the most important function blocks on the FON board. The small figure is a simplified block symbol of the FON board.

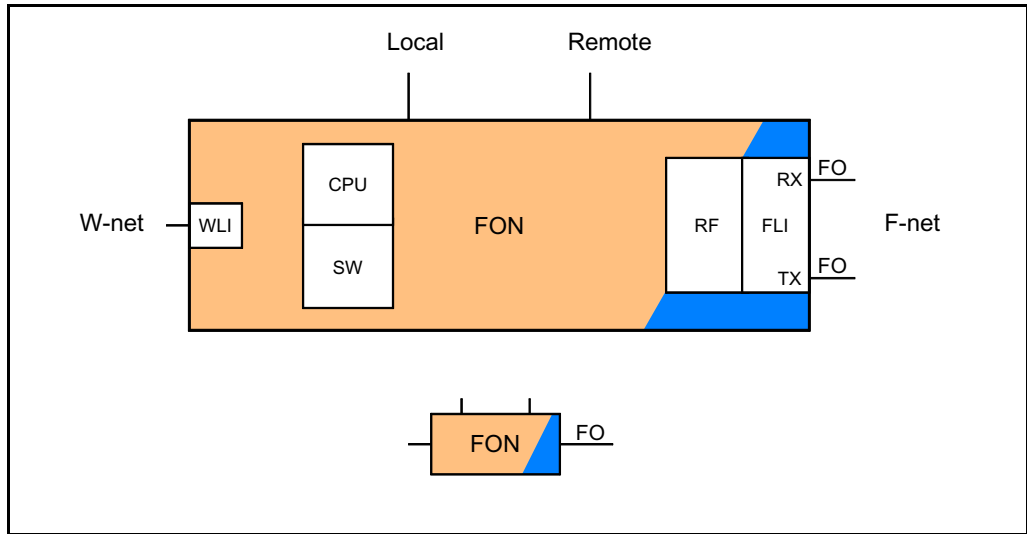

Figure 5-5. FON with communication interfaces

The CPU unit with loaded software (SW) controls the FON unit including the network communication. The RF block in Figure 5-5 converts electrical signals to optical signals and vice versa.

The local port is used for cable connection between the FON unit and an O&M workstation. PPP is used for communication via this port.

The remote port is used for remote connection between the FON unit and an O&M workstation via modem. PPP is used for communication via this port.

WLI is the communication port for W-net.

FLI is the communication port for F-net. In Figure 5-5, this part of the FON board is marked to indicate an optical part.

The W-net and F-net are interconnected in the FON board, which makes it possible to interconnect several F-nets via a W-net, see the small figure.

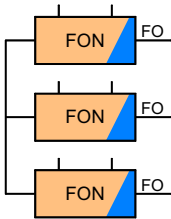

Network Example

An example of a repeater network with FON units is shown in Figure 5-6.

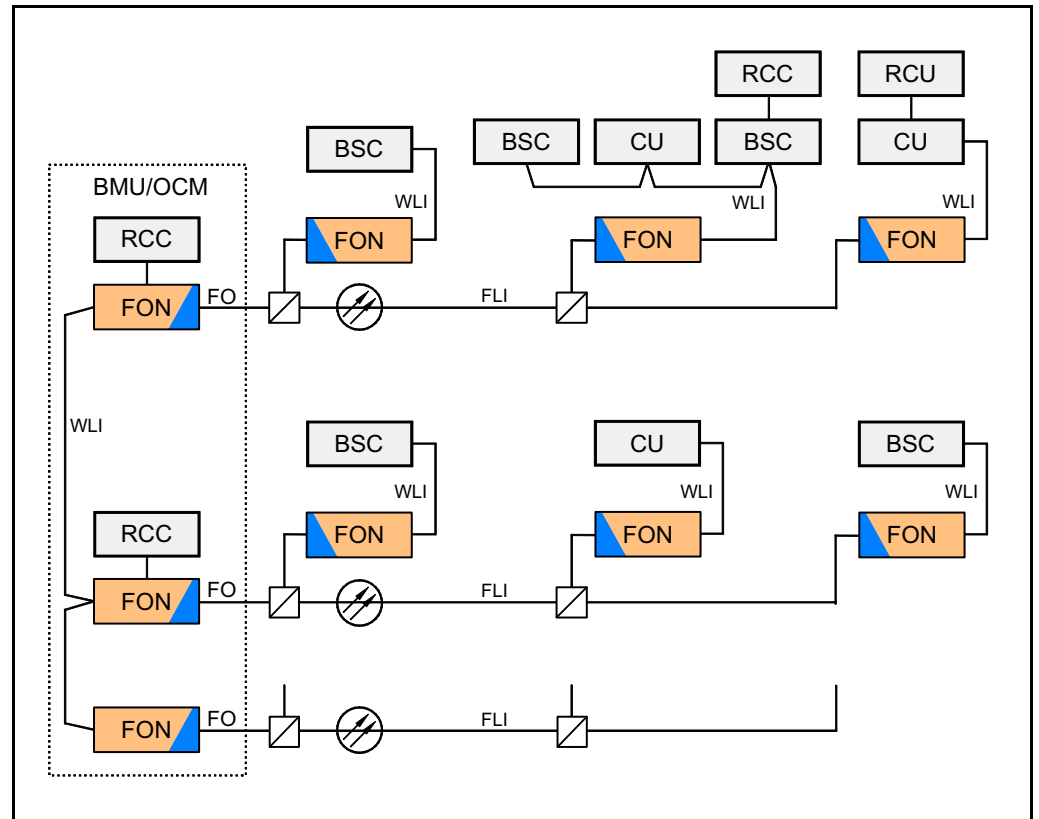

Figure 5-6. Repeater network example

This network has a BMU with three FON units as F-net master nodes. Two of which are gateway units. A backbone W-net interconnects the three FON units.

The three F-subnets (FLI) are connected to slave FON nodes via optical splitters. These slave FON nodes are connected to compact repeaters (BSC) and standard repeaters (CU) via W-subnets (WLI).

In this network there are four gateways connected to an RCU or RCC unit.

Further information about IP networks, IP address planning, and network configuration is found in the VM100 01/EN, *OM-Online, User's Manual*.

6. Commissioning

Read carefully Chapter 1, *Safety* before commissioning the optical system. See also the safety precautions for the current repeater or hub types.

Check all connections made during the installation. Also, ensure that both the mains plugs for repeaters equipped with two power supply units are connected to outlets supplied from the same fuse.

To fulfill the IP65 weather protective requirements, ensure that the cable strain relief bushings are properly tightened. Also, ensure that the gaskets at the cable inlets on the cabinet are properly fitted and not damaged.

When the installation is checked, commission the optical system as described in the following sections:

Equipment required for the commissioning is listed below.



This chapter contains commissioning instructions only. If you want to read descriptions of the various functions, see the previous chapters in this manual.

Some system configuration examples are found on page 6-6 and the following pages.

If you get problems when commissioning the system, please contact your nearest Powerwave representative.

Equipment Required

To be able to commissioning an optical system you will need the following:

- Optical power meter.
- Laptop with O&M software and an RS232 serial cable.
- Spectrum analyzer.
- Repeater tools.
- Optical clenaer.

Commissioning the Fiber Optic System

Commission the optical transmission system as described in the following instruction. The instruction covers the optical system only and is therefore applicable to all units with optical transmission, for instance BMU, RMU, OCM, FOR, and RH.

Figure 6-1 shows a fiber optic system in a BMU and a FOR. These units are also used as examples in the instruction.

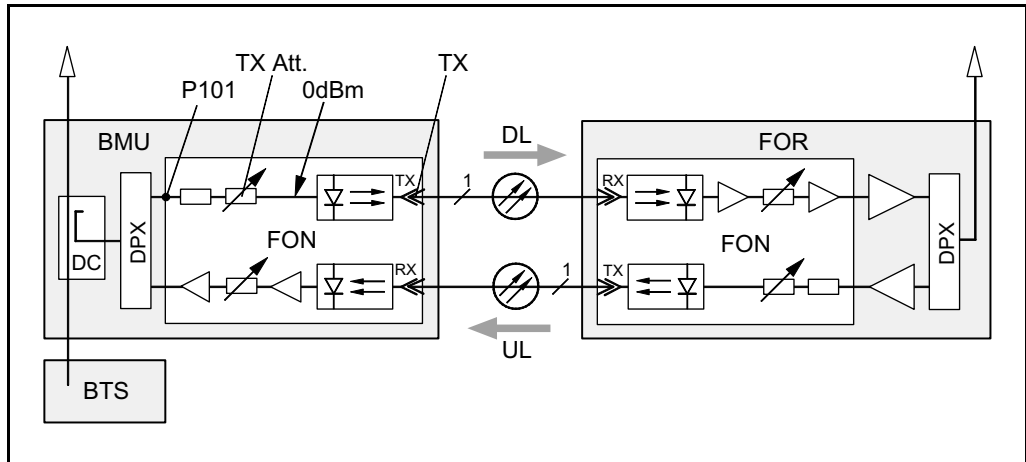

Figure 6-1. Master unit downlink path

Master Unit Downlink Path

1. Make sure the BMU is switched off.
2. Measure the downlink input RF signal power (from the BTS) at the FOM board connector 'P101' in Figure 6-1 (or at the OCM/BMU 19" rack) using a spectrum analyzer.

The signal power should be between +10dBm and +36dBm.

Write down the measured power value.

3. Switch the BMU on and wait until it is in operational mode.
4. Connect the O&M software to the FOM board.
5. Measure the optical output power from the FOM board (TX) using an optical power meter.
If there is only one slave unit on a short distance, choose the low power range. Otherwise, keep the default high power range.

If you are in doubt, choose high power and, if needed, change to low power if the received optical power is more than 4dBm at the slave unit.
6. Set the transmitter attenuation (TX Att.) to a value that gives the following optical transmitter an input power of approximately 0dBm. The attenuation is set via the O&M software (FOM configuration).

$$P_{P101} - 20\text{dB} - X\text{dB} = 0\text{dB}$$

Measured RF input signal level at P101 minus 20dB minus XdB attenuation equals 0dB. X is the attenuation set via O&M software. Write down the attenuation set.

7. Measure the optical output power from the FON board (TX) using an optical power meter. Write down the measured power value.

It is recommended to set date and time in the FON units, and to assign names to the units for future tracking.

Slave Units

Continue by performing the following on each slave unit.

8. Make sure the FOR/slave unit is switched off.
9. If two fibers are used, then make sure the uplink and downlink fibers are connected correctly in the FOR/slave unit.

The downlink fiber has to be connected to the RX port and the uplink fiber to the TX port of the FON unit, see Figure 6-2. The FOR in the figure is a compact repeater.

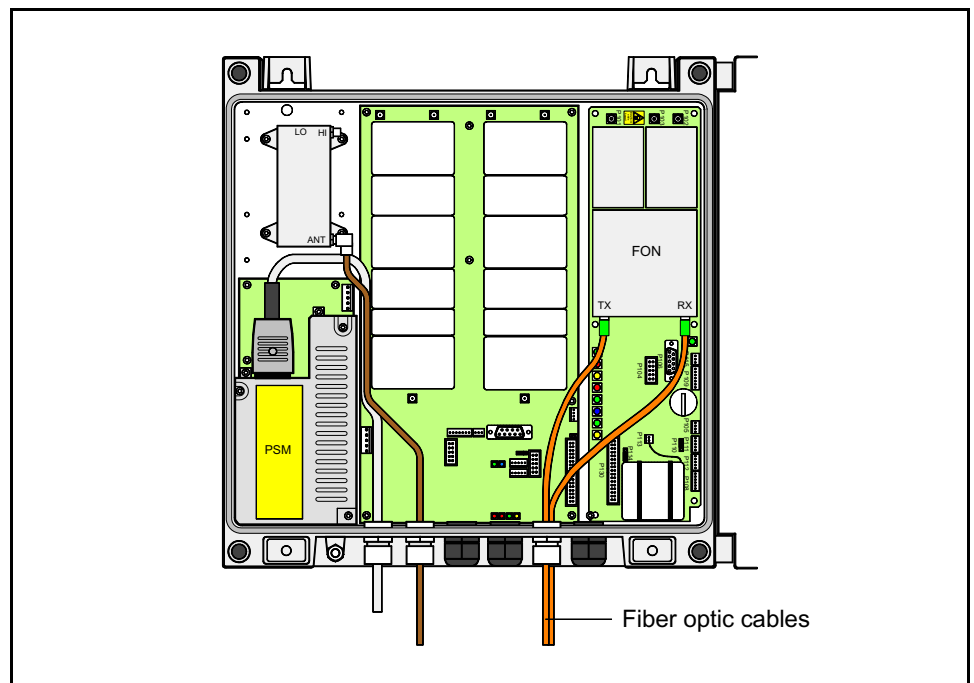

Figure 6-2. Fiber connection in a slave unit

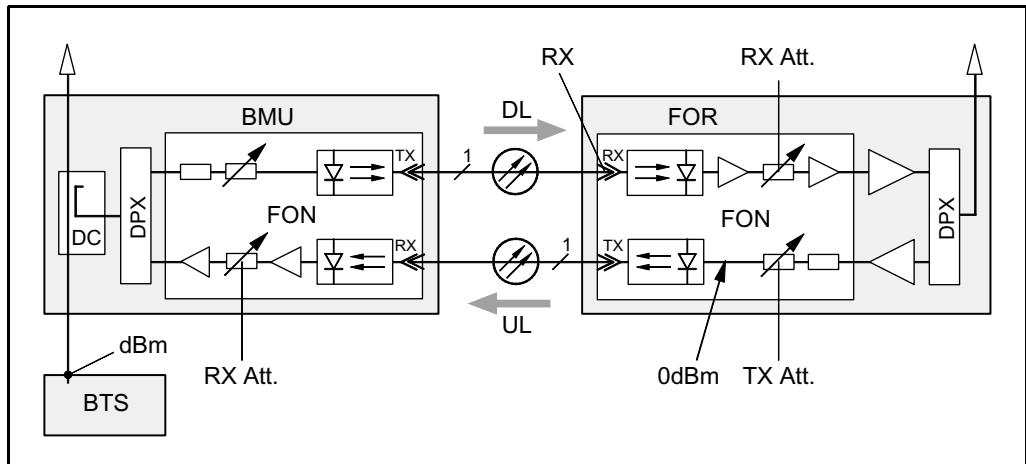

Figure 6-3. Slave unit downlink path, and uplink path

10. Switch the FOR on and wait until it is in operational mode.
11. Connect an O&M software to the FON board.
12. Measure the optical downlink input power ('RX' in Figure 6-3). The receiver level is measured via the O&M software (FON status).
Write down the measured optical power value.
13. Calculate the optical power loss from the TX port of the master FON board (step 5) to the RX port of the FOR/slave unit (step 12).
The loss includes fibers, WDMs, splitters, and connectors used in the current configuration.
The calculated optical loss should not exceed 15dB.
Write down the calculated optical loss value.
14. Set the receiver attenuation (RX Att.) via the O&M software (FON configuration).
An approximate receiver attenuation value can be set according to the calculated loss over the fiber in step 13. Choose value from the table.

Optical loss over fiber	Receiver attenuation
{ 10dB	10dB
} 10dB	5dB

15. Move the O&M software from the FON board to the repeater and set the desired repeater bandwidth and downlink gain.
16. Move the O&M software back to the FON board and set the transmitter attenuation (TX Att.) to a calculated value that gives the following optical transmitter an input power of approximately 0dBm.
17. Choose optical transmitter output power range via the O&M software as described in step 6.

- 18.** Move the O&M software back to the repeater and set uplink attenuation and gain.
Example of downlink and uplink settings are found in the following table.

Unit	Downlink	Uplink
BMU (FON)	5dB att.	10dB att.
FOR (FON)	10dB att.	5dB att.
BMU (RF)	60dB gain	60dB gain

The optical system is now ready for operation. A fine-tuning of the system should be done to get the most out of the system. And, the more nodes in the system the more reason to balance and fine-tune it.

The following section contains some system configuration examples.

System Configuration Examples

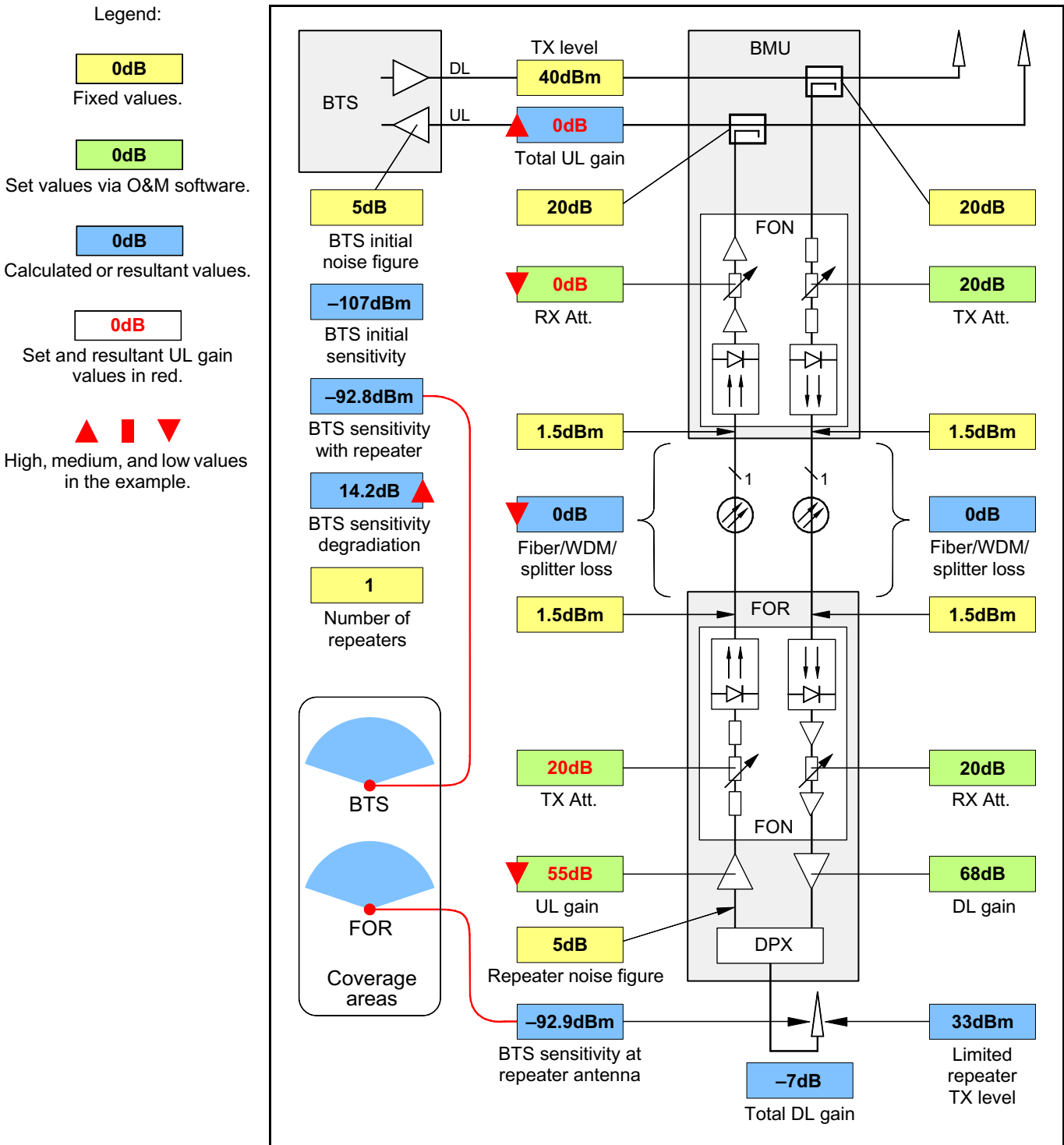

Figure 6-4. One FOR, low optical loss, low uplink gain and attenuation

Figure 6-4 shows a FOR connected with low optical loss, low uplink gain and low uplink attenuation. The *BTS sensitivity degradation* is high.

High total uplink gain and a *BTS sensitivity with repeater* very close to the *BTS sensitivity at the repeater antenna* indicates a similar coverage area for the BTS and the FOR.

- Legend:
- 0dB Fixed values.
 - 0dB Set values via O&M software.
 - 0dB Calculated or resultant values.
 - 0dB Set and resultant UL gain values in red.
 - ▲ ■ ▼ High, medium, and low values in the example.

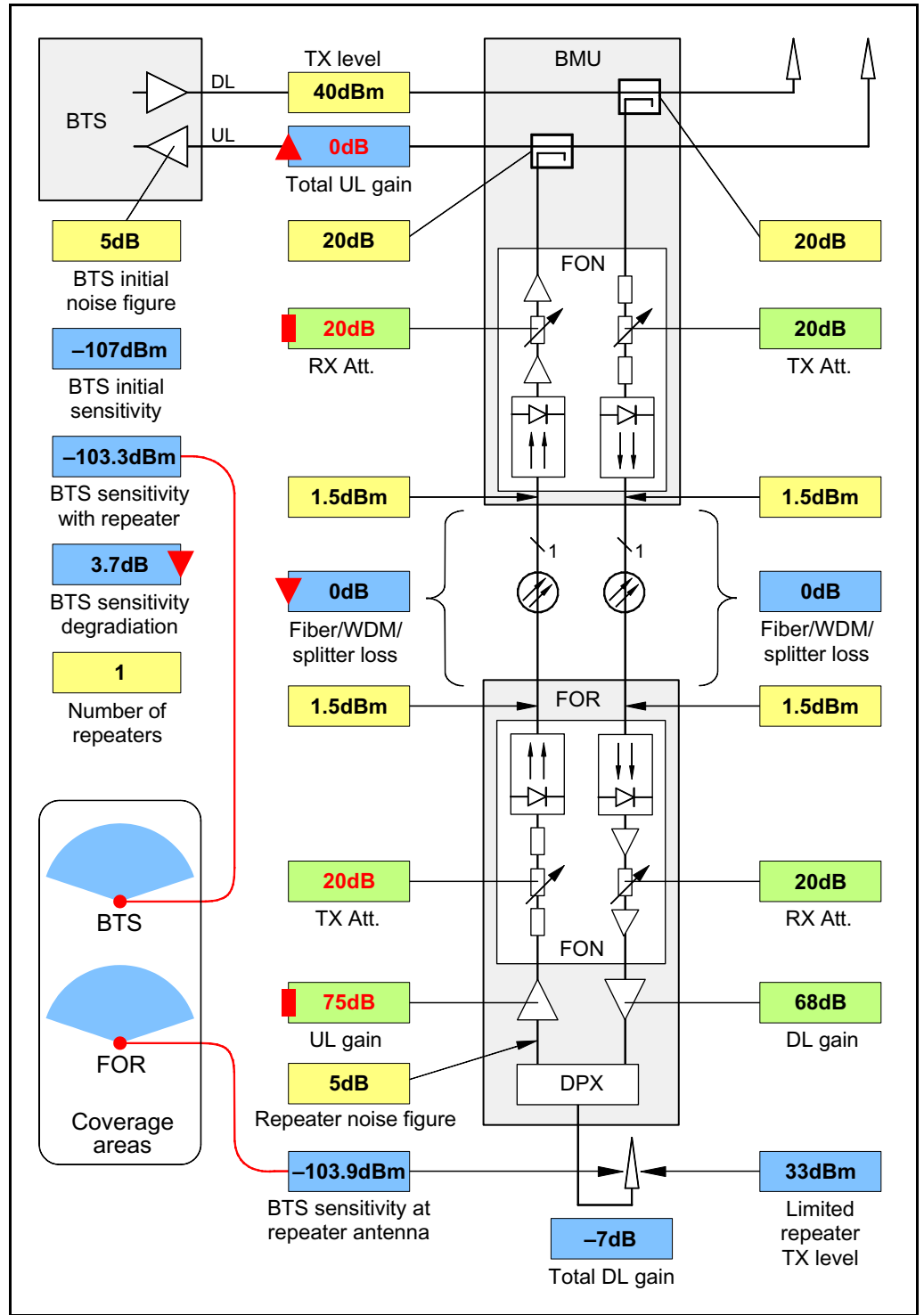

Figure 6-5. One FOR, low optical loss, medium uplink gain and attenuation

Figure 6-5 shows a FOR connected with low optical loss, medium uplink gain and medium uplink attenuation. The *BTS sensitivity degradation* is low.

High total uplink gain and a *BTS sensitivity with repeater* very close to the *BTS sensitivity at the repeater antenna* indicates a similar coverage area for the BTS and the FOR.

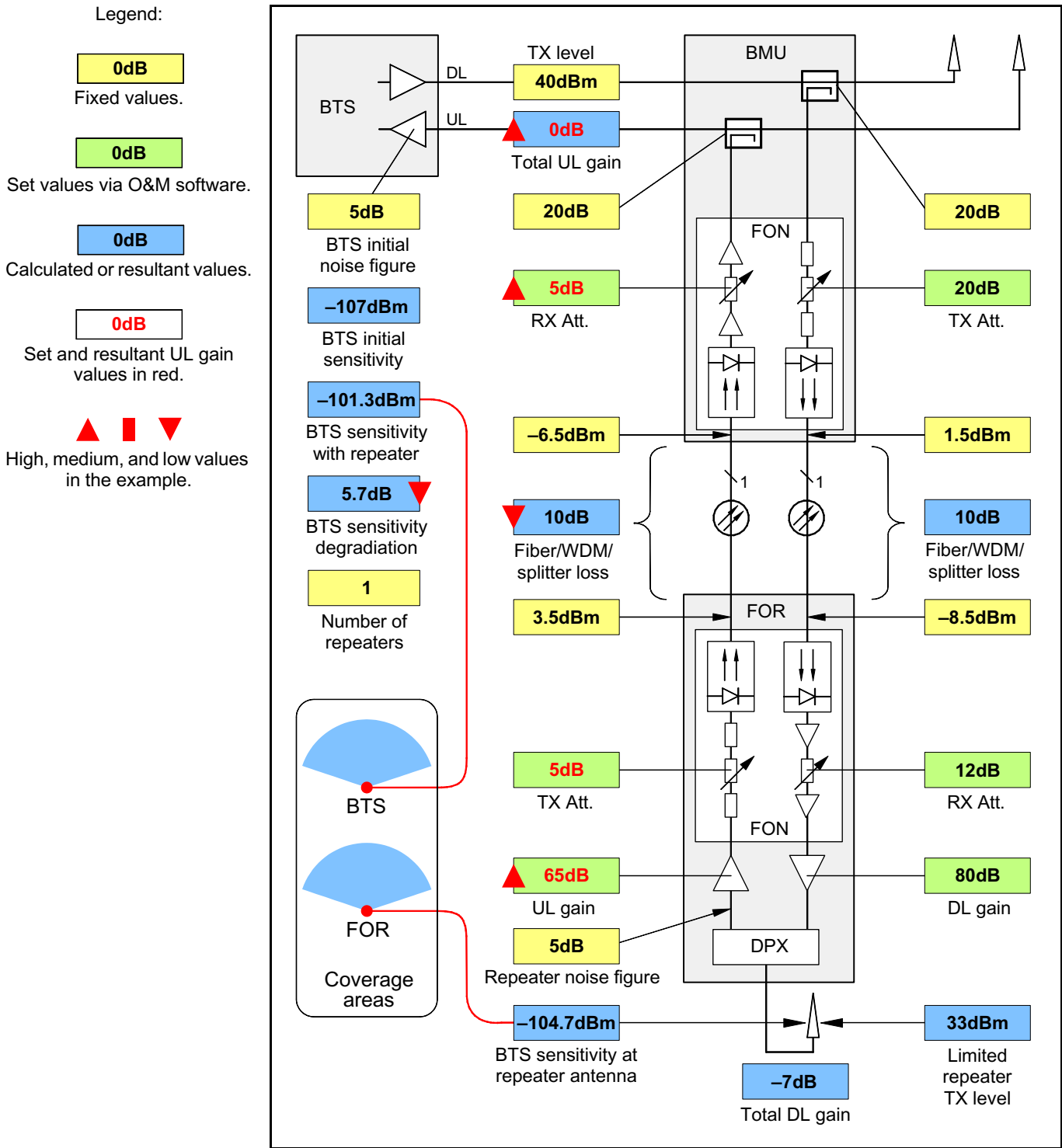

Figure 6-6. One FOR, low optical loss, high uplink gain and attenuation

Figure 6-6 shows a FOR connected with low optical loss, high uplink gain and high uplink attenuation. The *BTS sensitivity degradation* is low.

High total uplink gain and a *BTS sensitivity with repeater* very close to the *BTS sensitivity at the repeater antenna* indicates a similar coverage area for the BTS and the FOR.

- Legend:
- 0dB Fixed values.
 - 0dB Set values via O&M software.
 - 0dB Calculated or resultant values.
 - 0dB Set and resultant UL gain values in red.
 - ▲ ■ ▼ High, medium, and low values in the example.

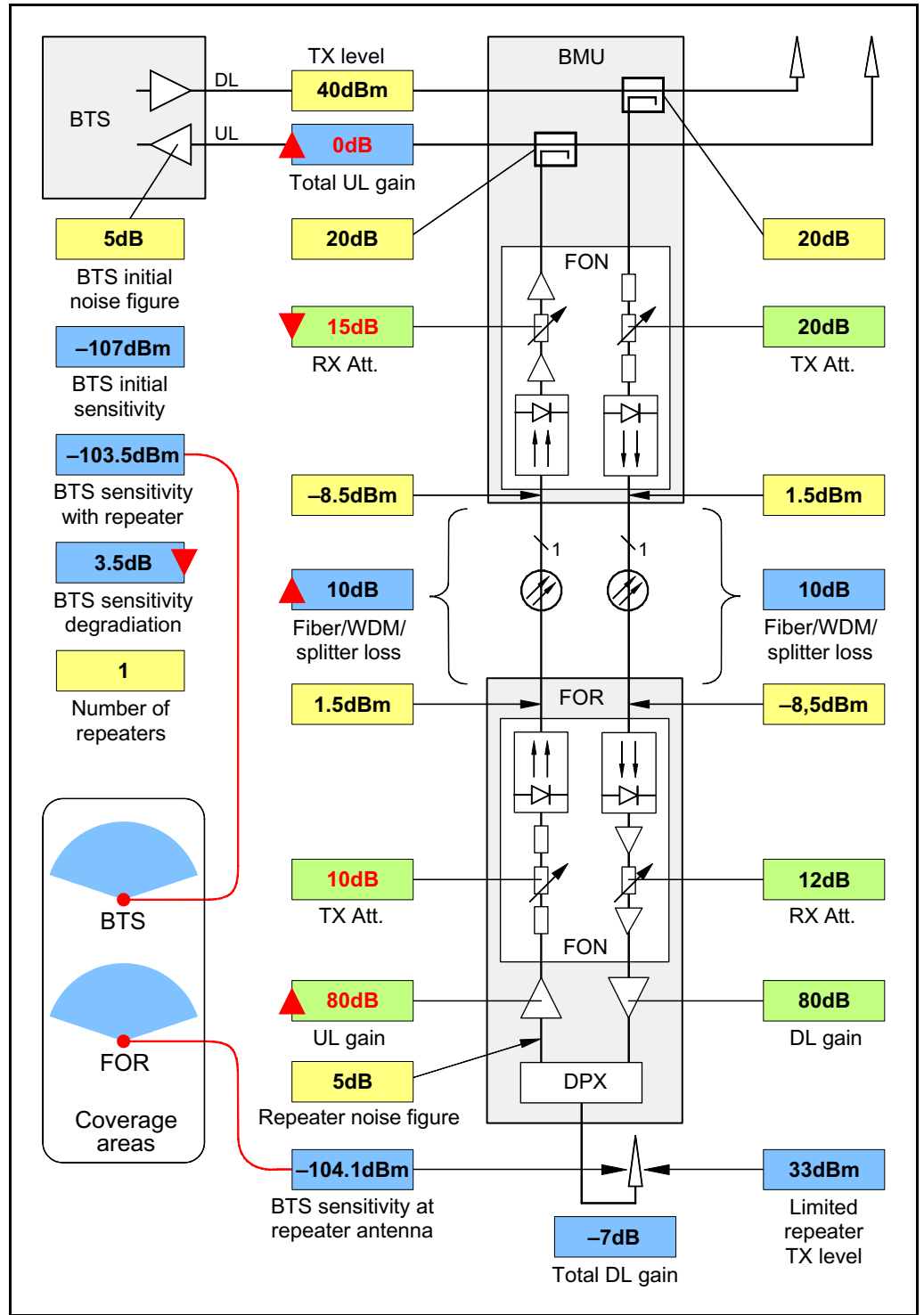

Figure 6-7. One FOR, high optical loss, high uplink gain

Figure 6-7 shows a FOR connected with high optical loss, high uplink gain and an uplink attenuation adapted to the optical loss. The *BTS sensitivity degradation* is low.

High total uplink gain and a *BTS sensitivity with repeater* very close to the *BTS sensitivity at the repeater antenna* indicates a similar coverage area for the BTS and the FOR.

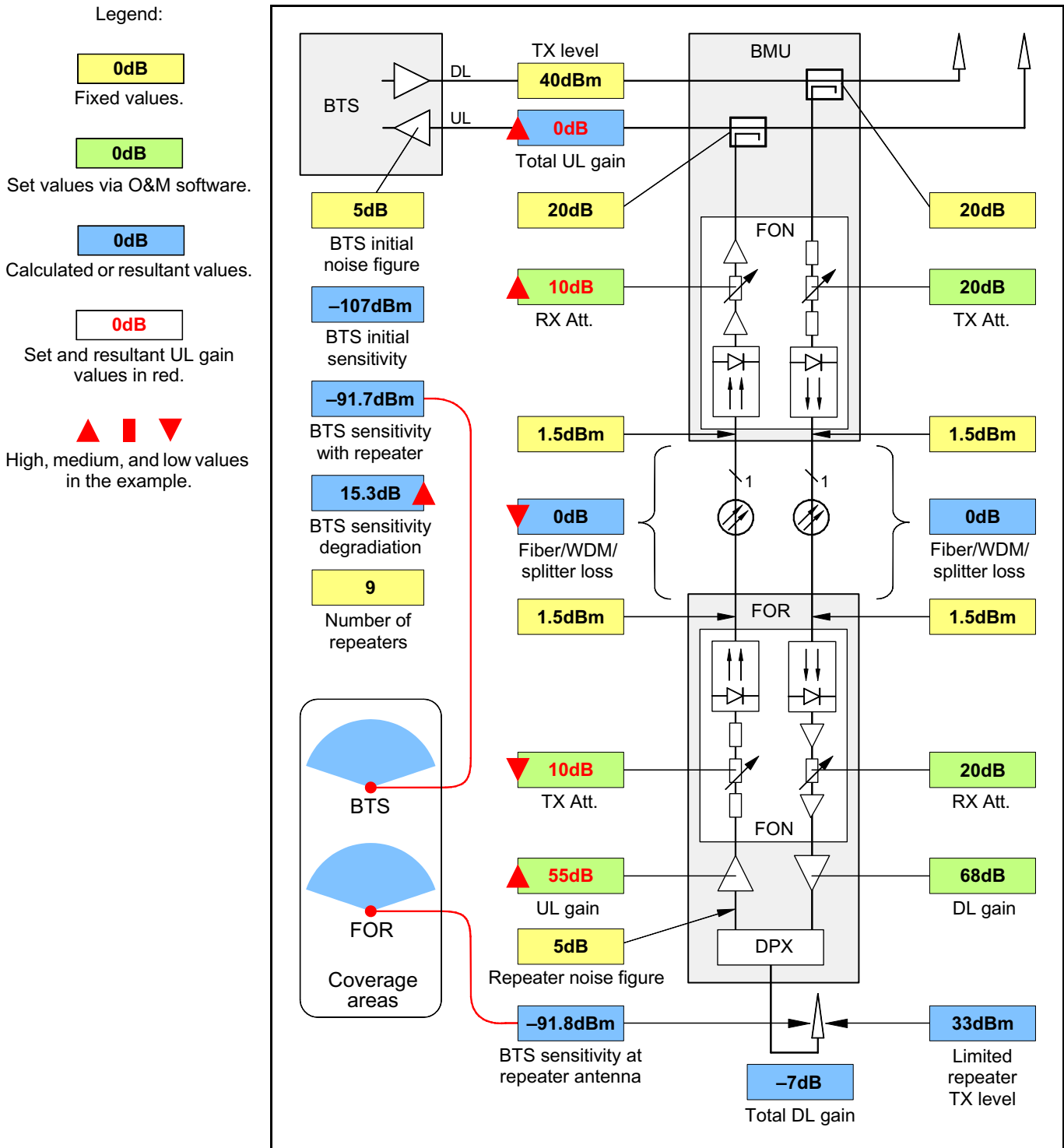

Figure 6-8. Nine FORs, low optical loss, high uplink gain and attenuation

Figure 6-8 shows one of nine FORs connected to one of three FON units in the BMU with low optical loss, high uplink gain and high uplink attenuation. The *BTS sensitivity degradation* is high.

High total uplink gain and a *BTS sensitivity with repeater* very close to the *BTS sensitivity at the repeater antenna* indicates a similar coverage area for the BTS and the FOR.

- Legend:
- 0dB Fixed values.
 - 0dB Set values via O&M software.
 - 0dB Calculated or resultant values.
 - 0dB Set and resultant UL gain values in red.
 - ▲ ■ ▼ High, medium, and low values in the example.

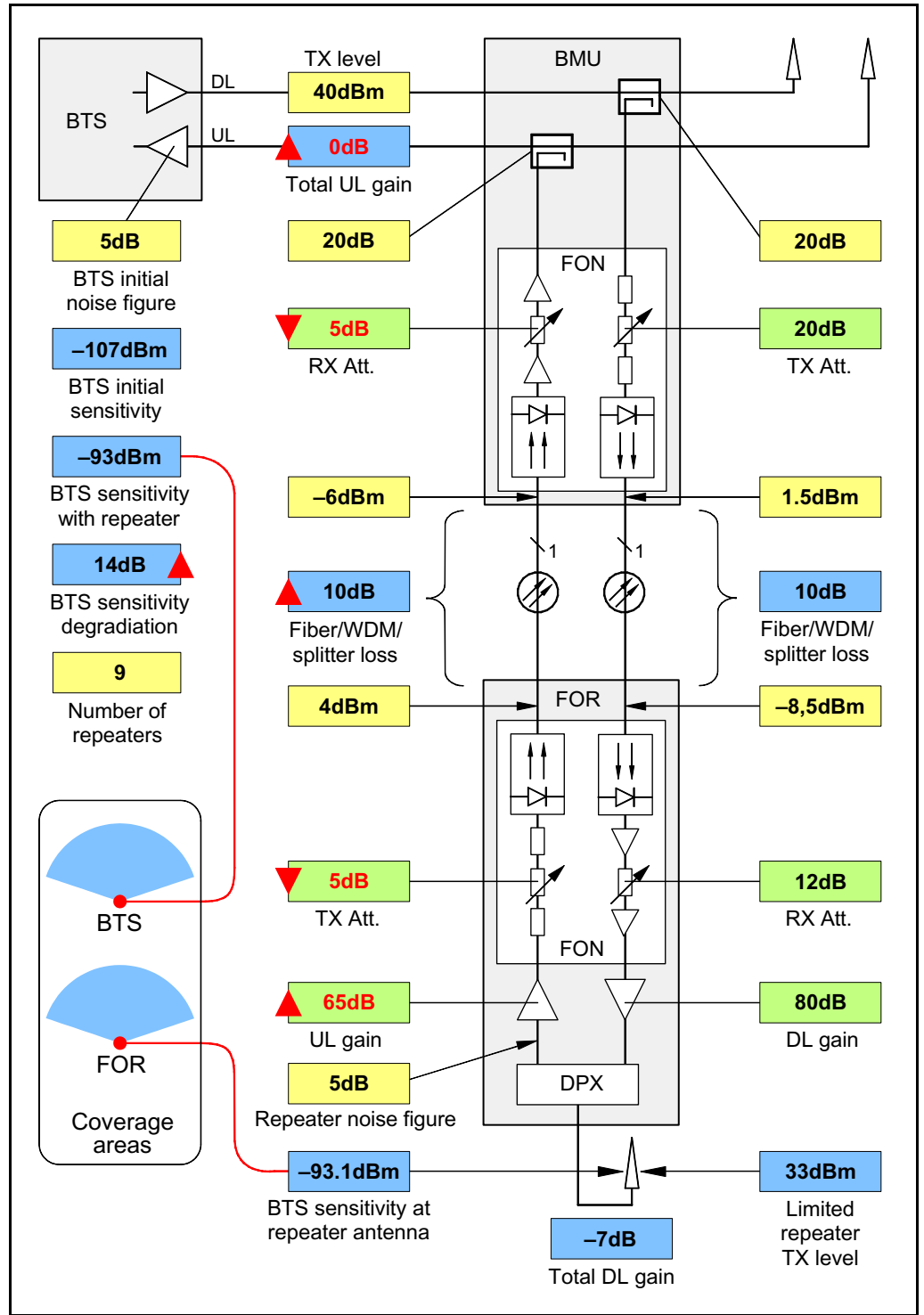

Figure 6-9. Nine FORs, high optical loss, high total uplink gain

Figure 6-9 shows one of nine FORs connected to one of three FON units in the BMU with high optical loss, high uplink gain and an uplink attenuation adapted to the optical loss. The *BTS sensitivity degradation* is high.

High total uplink gain and a *BTS sensitivity with repeater* very close to the *BTS sensitivity at the repeater antenna* indicates a similar coverage area for the BTS and the FOR.

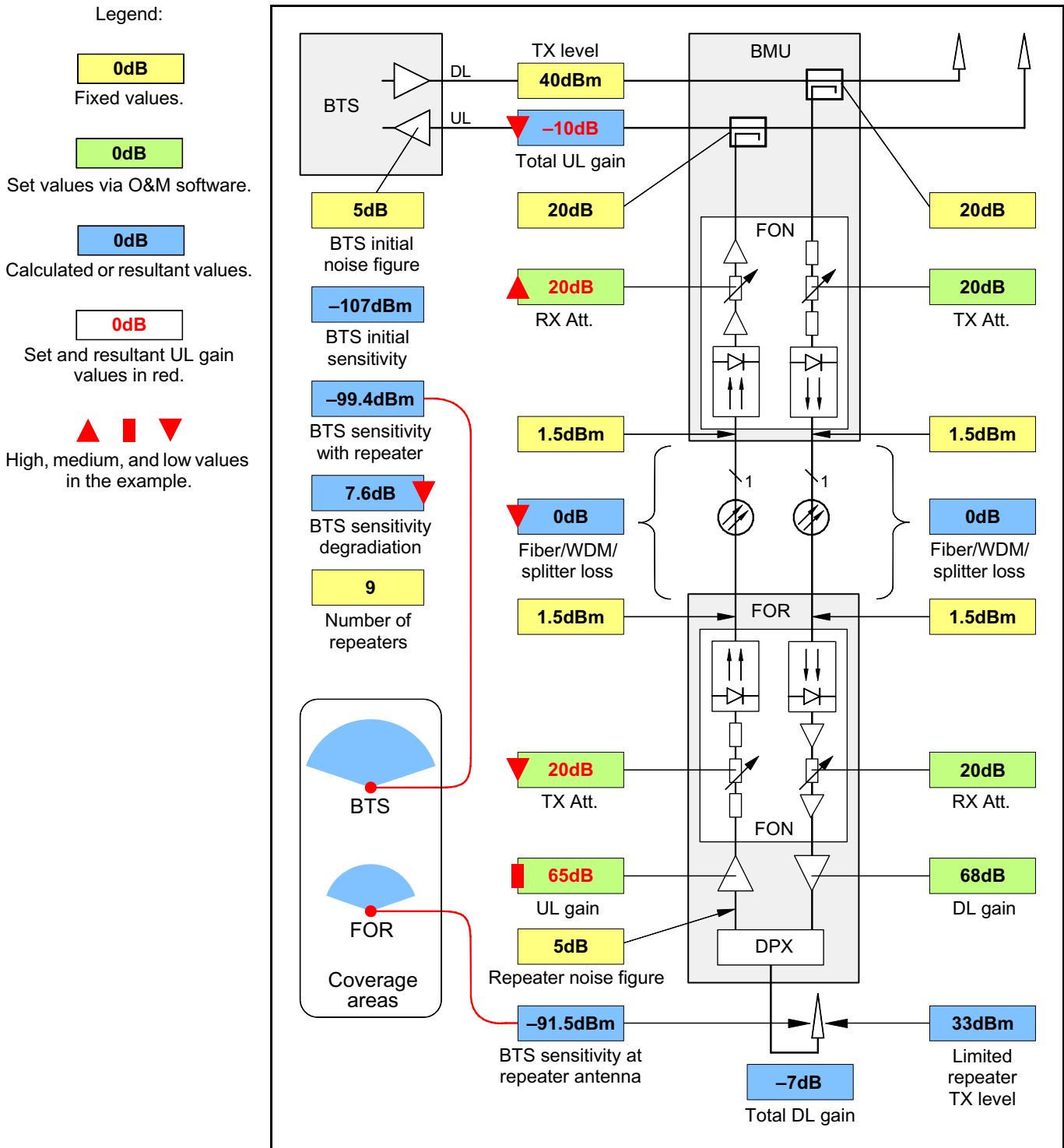

Figure 6-10. Nine FORs, low optical loss, low total uplink gain

Figure 6-10 shows one of nine FORs connected to one of three FON units in the BMU with low optical loss, medium uplink gain and high uplink attenuation. The *BTS sensitivity degradation* is low.

Low total uplink gain decreases the *BTS sensitivity with repeater* under the *BTS sensitivity at the repeater antenna* level, indicating a larger coverage area for the BTS than for the FOR.

- Legend:
- 0dB
Fixed values.
 - 0dB
Set values via O&M software.
 - 0dB
Calculated or resultant values.
 - 0dB
Set and resultant UL gain values in red.
 - ▲ ■ ▼
High, medium, and low values in the example.

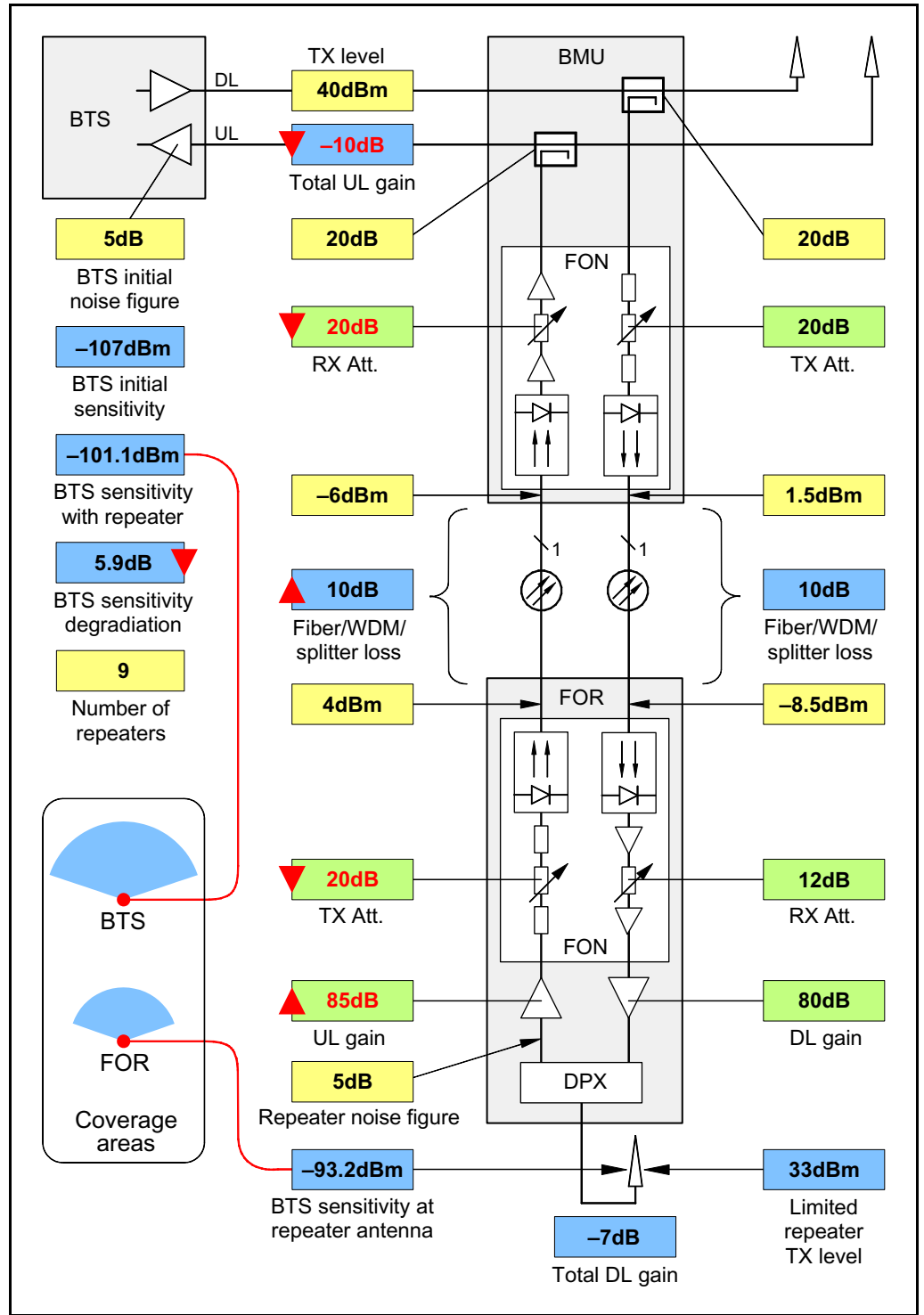

Figure 6-11. Nine FORs, high optical loss, low total uplink gain

Figure 6-11 shows one of nine FORs connected to one of three FON units in the BMU with high optical loss, and an uplink attenuation adapted to the optical loss. The *BTS sensitivity degradation* is low.

Low total uplink gain decreases the *BTS sensitivity with repeater* under the *BTS sensitivity at the repeater antenna* level, indicating a larger coverage area for the BTS than for the FOR.

7. Passive Devices

This chapter describes those passive components that are used to build optical fiber networks with two or more nodes.

These devices are:

- OSP, Optical splitters, page [7-2](#).
- WDM, wavelength division multiplexers, page [7-4](#).
- Fiber optic cables, page [7-6](#).
- Fiber optic connectors, page [7-9](#).

OSP, Optical Splitter

This section describes those types of optical splitters that are used to build repeater fiber networks. These are variants of three port optical splitters, also called beamsplitters or tee couplers.

After the general description, the graphic symbol for the optical splitter, and two examples of splitter usages are found.



Figure 7-1. Three port optical splitter

The optical splitter is used to split an optical signal in a common fiber port into two or more output fiber ports, and the other way around, that is to combine the signals from two or more input ports into one common port.

Optical splitters have to be used to interconnect more than two units in a fiber network. The signal power in the splitter output ports is divided, reducing the signal magnitude in each of the ports.

The signal magnitude reduction, or power loss, for the common types of optical splitters for repeater networks are found in the following table.

Splitter type	Loss
50/50 percent	3dB for each of the ports due to the specification. Typical loss is between 3.2dB and 3.5dB.
30/70 percent	5.2dB in the 30% port. 1.5dB in the 70% port.

Additional loss for optical connectors is approximately 0.5dB per connector.

The table indicates that a 50/50 percent splitter divides the signal power from the common fiber equally between the output fibers. The splitter has the same loss in the reverse direction.

A 30/70 percent splitter divides the signal power from the common fiber in a part with 30% of the common power and another part with 70% of the common power. The splitter has the same loss in the reverse direction.

Other types of splitters, such as 90/10, 95/5, and 99/1 percent are not used for repeater networks.

Graphic Symbol

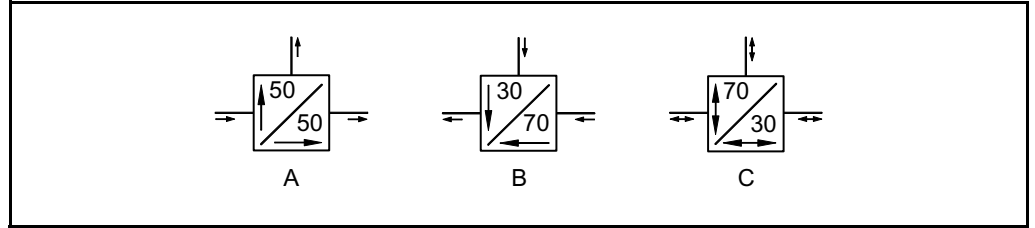

Figure 7-2. Optical splitter graphic symbol

Figure 7-2 shows the following three variants of an optical splitter graphic symbol (according to the EIA/TIA-587):

- A – A 50/50 percent splitter used for simplex splitting, from the common fiber to the two output fibers.
- B – A 30/70 percent splitter used for simplex combining, from the two input fibers to the common fiber.
- C – A 30/70 percent splitter used for duplex splitting/combining between the common fiber and the two input/output fibers.

Examples

These examples illustrate two networks using optical splitters.

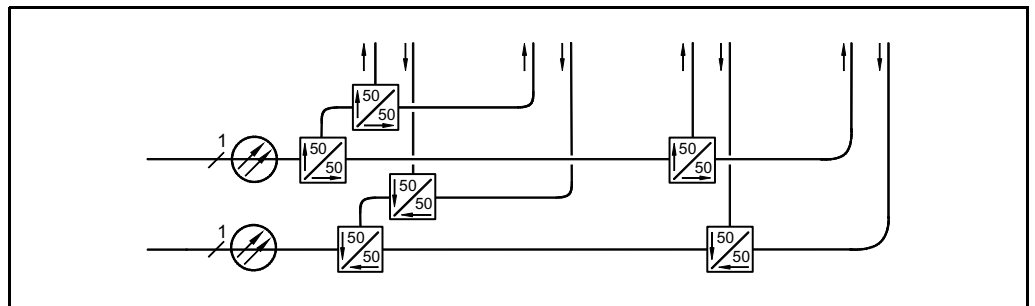

Figure 7-3. Optical splitters in a simplex network

Figure 7-3 shows a simplex network using optical splitters. The common fiber is divided into four output parts with 25% of the common power each.

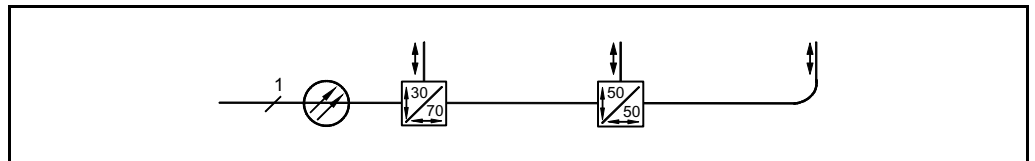

Figure 7-4. Optical splitters in a duplex network

Figure 7-4 shows a duplex network using optical splitters. The common fiber is divided into three parts with 30 – 35% of the common power each.

WDM, Wavelength Division Multiplexer

This section describes those types of optical multiplexers that are used to build repeater fiber networks. These are 1310nm and 1550nm WDMs.

After the general description, the graphic symbol for the multiplexer, and an example of WDM usage are found.

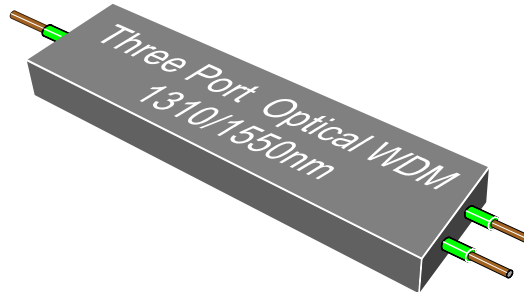

Figure 7-5. Three port WDM, Wavelength Division Multiplexer

A WDM is used to split two or more signals of different wavelengths in a common fiber port into two or more output fiber ports, and the other way round, that is to combine signals of different wavelengths from two or more input ports into one common port.

The WDM has a very low insertion loss, approximately 1dB. Additional loss for optical connectors is approximately 0.5dB per port.

The WDM has two important characteristics, *crosstalk* and *channel separation*.

- *Crosstalk*, also called *directivity*, is the WDM's ability to separate the demultiplexed channels. Each channel should appear only in the intended output port, not in any other output port. The crosstalk or diversity specification is thus a measurement of the channel isolation.
- *Channel separation* is the WDM's ability to distinguish different wavelengths. In most WDMs, the wavelengths used has to be widely separated.

There are two different ways to use WDMs with 1310 and 1550nm wavelengths. They can be used for single direction dual signal transmission, or for bi-directional transmission, see the following sections.

There are WDMs with a channel separation of 2nm, which is shown in the example further ahead in this section.

There is also a CWDM type (Coarse WDM) that has a channel separation of 20nm. This type of CWDM with a wider channels spacing can be used for laser emitters that have high spectral width or thermal drift. CWDM systems support transmission distances up to 50km.

Bi-directional transmission

Bi-directional, or duplex, transmission can be used to simultaneously communicate in both directions over the same fiber.

Figure 7-6 shows the principle of this communication type.

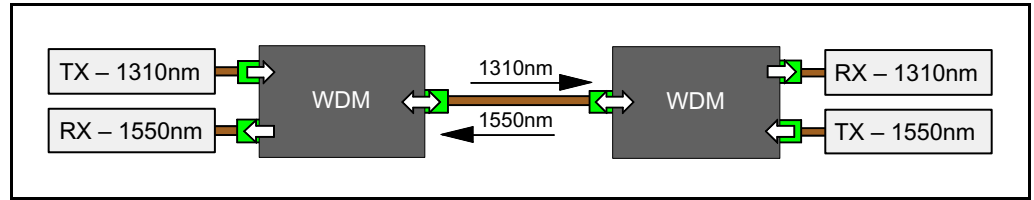

Figure 7-6. Bi-directional transmission

Graphic Symbol

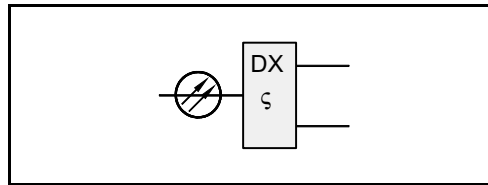

Figure 7-7. WDM graphic symbol

Figure 7-7 shows the graphic symbol for the optical WDM, Wavelength Division Multiplexer (according to the EIA/TIA-587).

Example

This example illustrates a duplex transmission using WDMs and optical splitters.

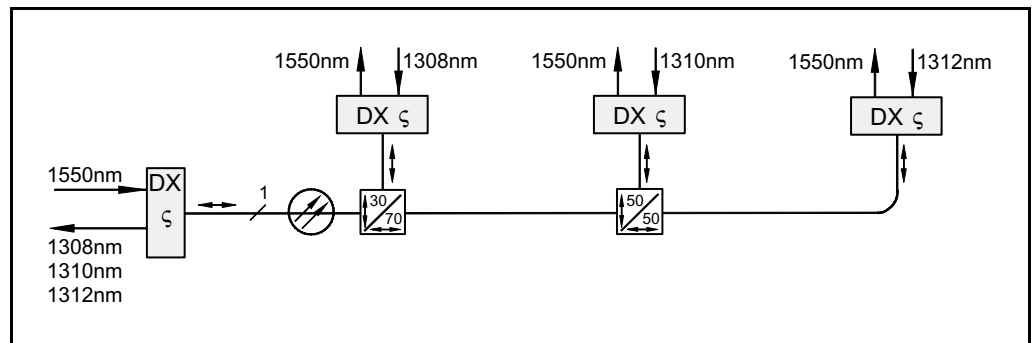

Figure 7-8. Duplex transmission with WDMs

Figure 7-8 shows a duplex fiber network with different wavelengths for downlink and uplink. The master unit transmits 1550nm and receives 1308nm, 1310nm, and 1312nm from the three slave units.

Fiber Optic Cables



Fiber optic 9/125 μ m single-mode patch cables for Powerwave repeaters are normally delivered with the system.

Recommended backbone cables: Single-mode 9/125 μ m fiber optic cables.

Single-mode 9/125 μ m fiber optic cables have a very good bandwidth-distance product and a low cable loss, see below.

To add cable length, permanent splices are generally used outside buildings while connectors are generally used inside buildings. Permanent splices are described below, connectors are described in the next section.

Bandwidth-distance product

The bandwidth-distance product (MHz 1 km) for this cable type is higher than 20,000 for both 1310nm and 1550nm. As a comparison, a 50/125 μ m multi-mode cable has a product between 300 and 1,500.

Cable loss

The cable loss is found in the following table.

Wavelength	Loss
1310nm	0.35dB per kilometer.
1550nm	0.20dB per kilometer.

Additional loss for optical connectors is approximately 0.5dB per connector.

The following diagram illustrates the attenuation differences between some copper coaxial cables and the single-mode fiber cable.

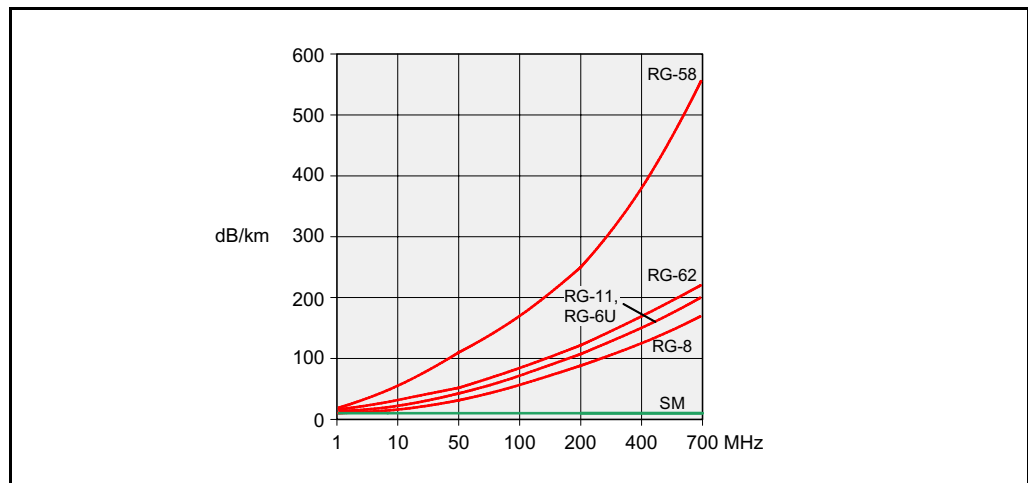

Figure 7-9. Attenuation for copper coaxial cables and fiber cable

Figure 7-9 shows the attenuation for RG-58, RG-62, RG-11, RG-8, RG-6U and single-mode fiber (SM).

The best of the copper coaxial cables, RG-8, has an attenuation of approximately 100dB/km at a frequency of 300MHz. This means that only 0.00000001% of the source power remains after a distance of 1km. In a 1550nm single-mode fiber cable of the same length, approximately 95% of the source power remains. This example is applicable for a splice-less cable with no other devices connected.

Miscellaneous fiber cable characteristics

Minimum bend radius for this cable type is 12mm.

The operating temperature range for the most common 9/125 μ m fiber cables is -60°C to $+85^{\circ}\text{C}$. The lowest temperature causes more trouble than the highest temperature.

Permanent splices

When a fiber cable has to be lengthened, the lowest attenuation and backreflection is obtained by performing a permanent fiber to fiber splice. Connectors can be used for the same purpose, but normally they have higher attenuation and backreflection. Permanent splices are also less expensive.

There are two main types of permanent fiber to fiber splices, *fusion splice* and *mechanical splice*.

Fusion splice

Fusion splice implies that the two cleaved fiber ends are butted together and heated until they fuse. To be able to perform this type of splice, a *fusion splicer* is required. This device has, in addition to an alignment and welding mechanism, also camera or microscope for supervision of the alignment and fuse procedures, and instruments to measure the power through the fiber splice.

The attenuation through a correctly performed fusion splice can be as low as 0.05dB.

Mechanical splice

Mechanical splice implies that the two cleaved fiber ends are joined into a structure, or fixed together with epoxy. To be able to perform this type of splice, a splicer device is required, which is less expensive than a *fusion splicer*.

The easiest way to perform a mechanical splice is to use a thin capillary tube in which the two fiber ends are inserted until they are in contact with each other. This method is called *capillary splicing*.

A mechanical splice may have a slightly higher loss and backreflection than a fusion splice. There is, however, index-matching gel to reduce this loss and backreflection.

Powerwave Patch Cables

Powerwave can provide a number of fiber patch cables with connectors for various applications. The following list contains some examples of these fiber cables.



Connector A	Connector B	Length	Part #
DIN/APC	DIN/APC	2m	PM403 07/4
DIN/APC	DIN/APC	5m	PM403 07/2
DIN/APC	DIN/APC	10m	PM403 07/1
DIN/APC	DIN/APC	25m	PM403 07/3
DIN/APC	FC/APC	2m	PM403 01/4
DIN/APC	FC/APC	5m	PM403 01/2
DIN/APC	FC/APC	10m	PM403 01/1
DIN/APC	FC/APC	25m	PM403 01/3
DIN/APC	FC/PC	2m	PM403 02/4
DIN/APC	FC/PC	5m	PM403 02/3
DIN/APC	FC/PC	10m	PM403 02/1
DIN/APC	FC/PC	25m	PM403 02/2
DIN/APC	SC/APC	10m	PM403 05/1
DIN/APC	SC/PC	10m	PM403 04/1
DIN/APC	ST	2m	PM403 03/2
DIN/APC	ST	10m	PM403 03/1
FC/APC	FC/APC	2m	PM403 09/1
FC/APC	FC/APC	10m	PM403 09/2
FC/PC	FC/APC	10m	PM403 06/1

As the number of cable lengths and connector combinations grow, please contact your nearest Powerwave representative for information about currently available cables.

Fiber Optic Connectors

There are a number of fiber optic connector types that have different characteristics, advantages, and disadvantages. There are, however, three basic connector parts that all of these types have in common. These are the connector body, the ferrule, and the coupling device.

Figure 7-10 illustrates a typical fiber connector in which these three parts, and other main parts, are pointed out.

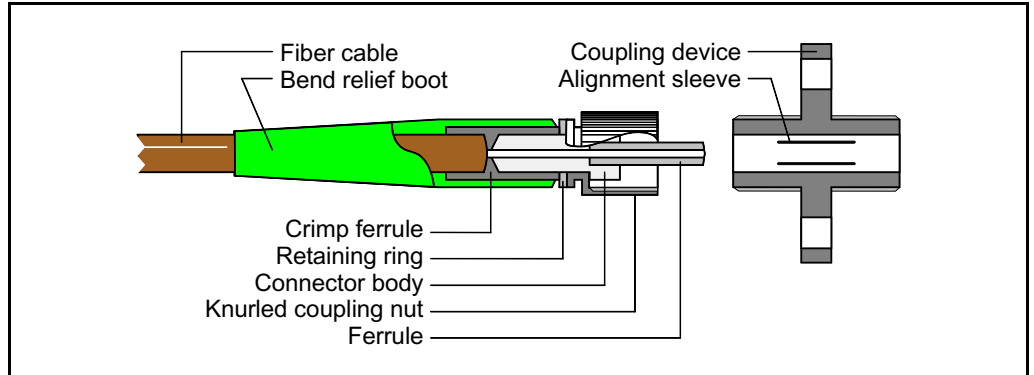

Figure 7-10. Typical fiber optic connector

Connector body

The connector body, or connector housing, holds the ferrule in a center line of the connector. The connector body is generally made of metal or plastic and it can consist of one or many pieces.

Ferrule

The ferrule holds and aligns the fiber. The ferrule is, when inserted in the coupler, guided by an alignment sleeve to the right position to meet the connected fiber with a minimum of misalignment.

The ferrule end and the fiber end are aligned in the same plane. The fiber face is polished in this plane to minimize power loss. Hackles, lips, fractures, and dirt at this face cause scattering and thus power loss.

Ferrules are typically made of metal or ceramic, but can also be made of plastic.

Coupling device

A coupling device, such as an alignment sleeve, is used instead of male and female connectors common to electric devices.

Fiber optic transmitters and receivers, as well as splitters and WDMs, often have the coupling devices built-in and can thus be connected with applicable cable connectors.

Connector insertion loss

All connectors have an insertion loss of 0.5dB.

Connector Types

The most common fiber optic connectors for Powerwave repeaters are briefly described below.

DIN



These are keyed, spring-loaded connectors with floating sleeves in the couplers. They have threaded coupling nuts.

DIN/APC, see [APC connectors](#) below.

FC



The ferrule in a FC connector has face contact (FC) with the joined connector. This type has a threaded coupling nut.

FC/APC, see [APC connectors](#) below.

FC/PC, see [PC connectors](#) below.

SC



The subscription channel (SC) connector is a push-pull connector that gives a click sound when pushed in or pulled out. The ferrule in this connector is decoupled from the cable and the connector body, which means that the ferrule is not affected by cable touches.

SC/APC, see [APC connectors](#) below.

SC/PC, see [PC connectors](#) below.

ST



The straight tip (ST) connector has a spring-loaded bayonet coupling that makes the ferrule not rotate during connection, which means that the insertion loss is consistent.

APC connectors



All APC connector types are angle polished connectors (APC). In such a connector, the ferrule with the fiber end face is not at straight angle to the fiber center axis (typical deviation for the connectors used is 8° but a deviation of 5° to 15° is common). These connectors have a low backreflection.

PC connectors



All PC connector types have the ferrule with the fiber end face polished in a certain curve for physical contact (PC). These connectors have a low backreflection.

E2000 connectors



The E2000 connector has a ceramic ferrule and a moulded plastic body that includes a push-pull latch mechanism. This connector has a spring loaded protective cap over the ferrule that protects the fiber end face from dirt and dust and also protects from laser emission.

Handling Connectors

Always have in mind that the fiber area in a fiber optic connector is very small. The diameter of the fiber in a single-mode connector is only $9\mu\text{m}$. Compared to a human hair, which is between 50 and $75\mu\text{m}$, the fiber diameter is only about a seventh of that diameter.

This means that a very small particle on the fiber end face causes trouble. A dust particle, $1\mu\text{m}$ in size, can suspend indefinitely in the air. On the fiber end face in a connector, this particle can cause a loss of 1dB. A $9\mu\text{m}$ dust particle can completely put an end to the signal.

Dust particles are usually $20\mu\text{m}$ or larger in diameter.

This makes it necessary to cover and clean optical connectors as described below.

Covering

An optical connector that is not in use must always be covered.

If, for example, an unprotected connector is dropped, the fiber end face may be damaged when it reaches the floor.

A protection boot is usually provided by the connector manufacturer. It should protect the entire connector, but at least the ferrule.

Cleaning

Always clean optical connectors immediately before inserting them into the coupling ports. But, wait until the cleaning liquid has get absolutely dry.

Use the following cleaning equipment:

- Fiber cleaning cloths.
- Denaturated alcohol.
- Canned dry air.
- 30X microscope (for cleaning verification).

Clean as follows:

1. Ensure the laser transmitter is off.
2. Clean by using a cleaning device.

Or:

- Saturate the fiber cleaning cloth with alcohol and clean the entire connector, especially the ferrule with the fiber end face. The cloth must not be dry.
- Verify the cleaning result by using the microscope.
- Canned air can be used to remove particles from the coupling port. Do not use cleaning liquid in the coupling port.
- Never touch the fiber end face.

8. Troubleshooting

This troubleshooting guide is applicable to a BMU connected to a BTS. The BMU is also the master unit in a fiber optic network built-up with FON units, one in the BMU and one in each of the connected repeaters.

This guide assumes that no gateway is available in the repeater network, and that alarms are indicated via an alarm relay in the BMU.

At the BMU site

1. Inspect the BTS and BMU sites.

If a general inspection of the BTS site does not explain the cause of the error, then open the cabinet of the BMU.

2. Check the power in the BMU.

This includes the BMU power supply and the fuse in the distribution panel.

If a replacement of the PSU does not solve the problem, then check the power distribution cable from the PSU to the FON unit.

3. Check the red FAULT and the green FLI/F2F indicators.

If neither the red FAULT indicator in the BMU or the green FLI/F2F indicator are blinking, then the FON unit is not communicating properly with any of the remote repeaters.

If there are more than one repeater in the repeater network, then the problem is most likely related to the fiber at the BMU site, or the fiber cable between the BMU and the repeaters.

4. Measure the received uplink 1310nm optical power from the repeater at the patch cables in the BMU.

If the measured optical power is higher than -10dBm , then proceed with step 5.

If there is no optical power, then check the signal power at the patch panel.

5. Measure the optical uplink power at the RX port of the current FON unit.

If the signal power is OK, then proceed with step 6.

If there is no power in the RX port, then clean the connectors and measure again.

If there is still no power in the RX port, then replace the FON unit with the passive devices (keep the FON board). The problem is very likely related to a malfunctioning splitter or WDM.

6. Measure the optical downlink transmitting power at the TX port of the same FON unit.

If the signal power is not OK, then replace the FON board.

At the repeater site

7. Repeat from step 2 to step 6 but now in the repeater.
8. If there are further repeaters in the network, then measure the optical output power to the next repeater.

If there is no power, then the problem most likely refers to the optic splitter. Replace the FOU unit with the passive devices (keep the FON board).

A malfunctioning splitter can also be the cause of lost repeaters between the BMU and the current site.

9. As soon as the optical system works, log on to the repeater and read the RF information in the event log.

If the error is caused by the RF system, then copy all settings from the current RF unit into a new RF unit and replace the RF unit.

The quickest way to determine if the RF level is OK in the repeater is to log on to the repeater and check the RSSI values for the BCCH channel. This value should be between -40dBm and -50dBm .

If the RSSI value is not between these values and the FON unit works properly, then measure the RF level from the FOU to the repeater DC coupler using a sitemaster, spectrum analyser, or similar.

If the loss is 20dB or more, then the LNA amplifier or the DPX filter is malfunctioning.

Index

A

Abbreviations	V
APC connectors	7-10

B

BATT, green LED	3-7
Beamsplitter	7-2
BOOT, red LED	3-7

C

Capillary splicing	7-7
CHARGE, yellow LED	3-7
Commissioning	6-1

D

DATA, blue LED	3-7
DIN connectors	7-10

E

E2000 connectors	7-10
ESD	1-6

F

FAULT, red LED	3-7
FC connectors	7-10
Fiber-Optic Node	3-1
FLI	5-2
FLI, green LED	3-6
F-link	5-2
F-net	5-2
F-net characteristics	5-4
FON	3-1
FON operational control	3-11
FON unit	5-6
Fusion splice	7-7
Fusion splicer	7-7

G

Graphic symbol, optical splitter	7-3
Graphic symbol, WDM	7-5

I

Introduction	2-1
IP	5-2
IP network	5-1
IP network requirements	5-3
IP terminology	5-2

L	
Link	5-2
M	
Mechanical splice	7-7
N	
Net and link	5-2
Node units	5-5
O	
OPER, green LED	3-7
Operational control, FON	3-11
Optical splitter	7-2
Optical splitter graphic symbol	7-3
OSP	7-2
P	
PC connectors	7-10
Port section	
LOCAL O&M	3-9
Ports	
P101 RF input	3-8
P102 RF output	3-8
P103 RF low power output	3-8
P104 Debug	3-9
P105 Front LED indicators	3-9
P106 PC	3-9
P108 Power	3-9
P109 Alarm	3-9
P110 W-link jumper	3-10
P111 WLI	3-10
P112 WLI	3-10
P113 Batteries	3-10
P114 Backup power output	3-10
P115 Future port	3-10
P116 Power	3-9
P130 RCC	3-10
RX	3-8
TX	3-8
POWER, yellow LED	3-7
Q	
Questionnaire	Q-1
R	
R2R	3-4, 5-2
R2R net	5-2
R2R terminology	5-2
S	
Safety	1-1
beryllium oxide	1-1
electric shock	1-1
hydrogen fluoride	1-1
laser transmitter	1-2

lithium battery	1-1
polytetrafluoro ethylene	1-1
PTFE	1-1
SC connectors	7-10
Single-Mode Fiber	8-1
SLW	3-4, 5-2
ST connectors	7-10
Static electricity	1-6

T

Tee coupler	7-2
Terminology	5-2

W

Wavelength Division Multiplexer	7-4
WDM graphic symbol	7-5
WLI	3-4, 5-2
WLI, green LED	3-7
W-link	5-2
W-net	3-4, 5-2

Questionnaire

The aim of this manual is to guide you when installing and operating the Powerwave repeaters, and to answer questions that may turn up. To ensure that we provide appropriate information for these purposes, we would appreciate your views and suggestions on how to improve the manual in this direction. Please, fill out the following questionnaire and send it to us.

1

Have you read entire sections or do you use the manual to look up specific information when needed?

- Read entire sections
- Look up specific information

Comments: _____

2

Do you think the information is easy to find and understand?

- Yes
- No

Comments: _____

3

Do you find any function of the Powerwave repeater hard to understand, a function which should be subjected to more detailed description?

- Yes
- No

If yes, which one: _____

4

Do you have any suggestions on how we can improve this manual?

Title (Mr/Ms/Other): _____ Initial: _____
 Surname: _____ Job title: _____
 Company: _____ Address: _____
 City: _____ Country: _____ Phone: _____

Thanks for your kind help. It's very valuable to us.

POSTAGE
STAMP

Powerwave Technologies Sweden AB
Customer Care
SE-187 80 Täby
Sweden

If you prefer to send by mail, fold here and tape.
No envelope required.

If you prefer to send by fax, use this number: **+46 8 540 824 85**