

***G3L-1929-160
Multi-Carrier
Power Amplifier
Installation and
Service Manual***

044-05237 Rev A
June 2006



© 2006 Powerwave Technologies Incorporated. All rights reserved.

Powerwave Technologies, and the Powerwave logo are registered trademarks.

This Powerwave product is intended only for installation in a RESTRICTED ACCESS LOCATION and this Powerwave product is designed to operate within the normal operating (typical operating) ranges or conditions specified in this document. Operation of this equipment beyond the specified ranges in this document may cause:

1. Spurious emissions that violate regulatory requirements.
2. The equipment to be automatically removed from service when maximum thresholds are exceeded.
3. The equipment to not perform in accordance with its specifications.

It is the operator's responsibility of the operator to ensure this equipment is properly installed and operated within Powerwave operating specifications to obtain proper performance from the equipment and to comply with regulatory requirements.

For PERMANENTLY CONNECTED EQUIPMENT, a readily accessible disconnect device shall be incorporated in the building permanent wiring.

Warnings, Cautions, and Notes

Warnings, Cautions, and Notes are found throughout this manual where applicable. The associated icons are used to quickly identify a potential condition that could result in the consequences described below if precautions are not taken. Notes clarify and provide additional information to assist the user.



WARNING: This warning symbol means danger. You are in a situation that could cause bodily injury or death. Before working on any equipment, be aware of the hazards involved with electrical and RF circuits and be familiar with standard practices for preventing accidents.



CAUTION: The caution symbol means reader be careful. In this situation, the user might do something that could result in equipment damage or loss of data.

NOTE The note symbol means reader take note. Notes contain helpful suggestions or references to material not covered in this document. Procedures are not contained in notes.

Revision Record

Revision Letter	Date of Change	Reason for Change
A	June 2006	Initial Release

Table of Contents

Chapter 1 - Product Description

1.1 Introduction	1-1
1.2 Scope of Manual	1-1
1.3 Product Description	1-1
1.4 Functional Description	1-1
1.4.1 Preamplifier	1-3
1.4.2 Main and Error Amplifiers	1-3
1.4.3 Feed-forward Loop Control Circuits	1-4
1.4.4 Pilot Tone Generator	1-4
1.4.5 Controller	1-4
1.5 Cooling	1-4
1.6 Power Distribution	1-5

Chapter 2 - Controls and Indicators

2.1 Introduction	2-1
2.2 MCPA Controls and Indicators	2-1
2.2.1 MCPA Alarms	2-1
2.2.2 MCPA Connectors	2-3

Chapter 3 - Installation

3.1 Introduction	3-1
3.2 Unpacking and Inspection	3-1
3.2.1 Damaged Equipment	3-1
3.3 Air Conditioning Requirement	3-1
3.4 MCPA Installation Instructions	3-1
3.5 Initial Start-up and Operating Procedures	3-3

Chapter 4 - Maintenance

4.1 Introduction	4-1
4.2 Periodic Maintenance	4-1
4.3 MCPA Performance Tests	4-1
4.4 Troubleshooting	4-1
4.5 MCPA Removal and Replacement	4-1
4.6 Return For Service Procedures	4-2
4.6.1 Obtaining An RMA	4-2
4.6.2 Repackaging for Shipment	4-2

Chapter 5 - Specifications and Drawings

5.1 Multi-Carrier Power Amplifier Specifications	5-1
--	-----

List of Figures

Figure 1-1 MCPA Front and Rear Isometric Views	1-2
Figure 1-2 MCPA Functional Block Diagram	1-3
Figure 2-1 MCPA Controls and Indicators	2-1
Figure 2-2 MCPA Interface Connector	2-3
Figure 3-1 MCPA Locking Thumbscrews and Connectors	3-2
Figure 4-1 MCPA Performance Test Setup	4-2
Figure 5-1 MCPA Side View with Dimensions	5-2
Figure 5-2 MCPA Bottom View with Dimensions	5-3

List of Tables

Table 2-1 MCPA Controls and Indicators	2-2
Table 2-2 MCPA Alarm States	2-2
Table 2-3 MCPA Connector Pinouts	2-4
Table 3-1 MCPA Unpacking and Inspection Instructions	3-1
Table 3-2 MCPA Installation	3-2
Table 3-3 Initial Start-up Procedure	3-3
Table 4-1 Recommended Periodic Maintenance	4-1
Table 4-2 Recommended Test Equipment	4-2
Table 4-3 MCPA Performance Testing	4-3
Table 4-4 Troubleshooting	4-3
Table 4-5 MCPA Removal and Replacement	4-4
Table 5-1 MCPA Specifications	5-1

Chapter 1

Product Description

1.1 Introduction

This manual contains information and procedures for the installation, operation, and maintenance of the G3L-1929-160 Multi-Carrier Power Amplifier (MCPA).

1.2 Scope of Manual

This manual is intended for use by service technicians familiar with similar types of equipment. It contains service information required for the equipment described and is current as of the printing date. Changes which occur after the printing date may be incorporated by a complete manual revision or alternatively as additions. The manual is organized into the following chapters:

- Chapter 1 - Product Description
- Chapter 2 - Controls and Indicators
- Chapter 3 - Installation
- Chapter 4 - Maintenance
- Chapter 5 - Specifications

1.3 Product Description

The MCPA shown in Figure 1-1 is a linear, feed-forward multi-carrier power amplifier that operates in a 60 MHz frequency band from 1930 MHz to 1990 MHz with an instantaneous bandwidth of 40 MHz. The instantaneous bandwidth is the maximum frequency band in which any two or more signals can occupy. The instantaneous bandwidth of the MCPA is set automatically.

The MCPA is modular in design and ideally suited for use in GSM, EDGE, CDMA, and W-CDMA base stations. The MCPA provides a gain of 63 dB to supply a 160 watt output. Refer to Figure 1-2 for the MCPA functional block diagram. Refer to Chapter 5 for the MCPA specifications.

1.4 Functional Description

The MCPA is a self-contained module typically operated in parallel with other identical MCPAs as part of a subrack assembly.

The MCPA consists of the following major functions:

- Preamplifier
- Main and error amplifiers
- Feed-forward loop control circuits
- Pilot tone generator
- Controller

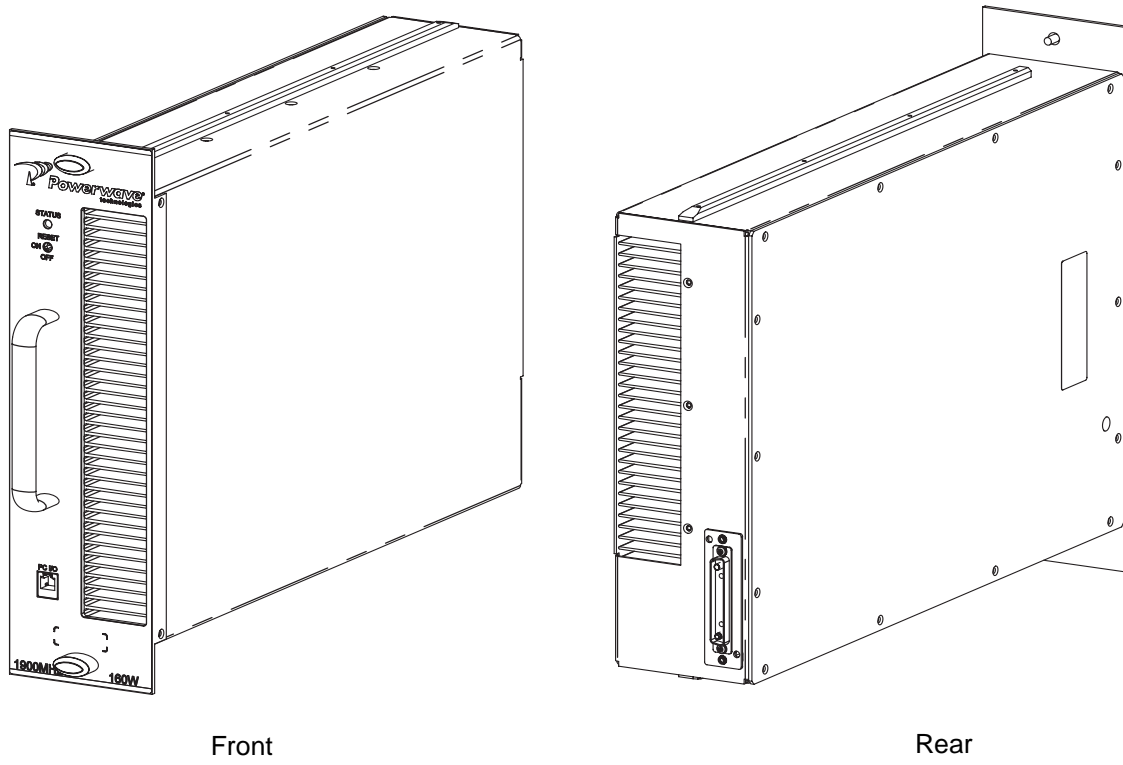

Figure 1-1 MCPA Front and Rear Views

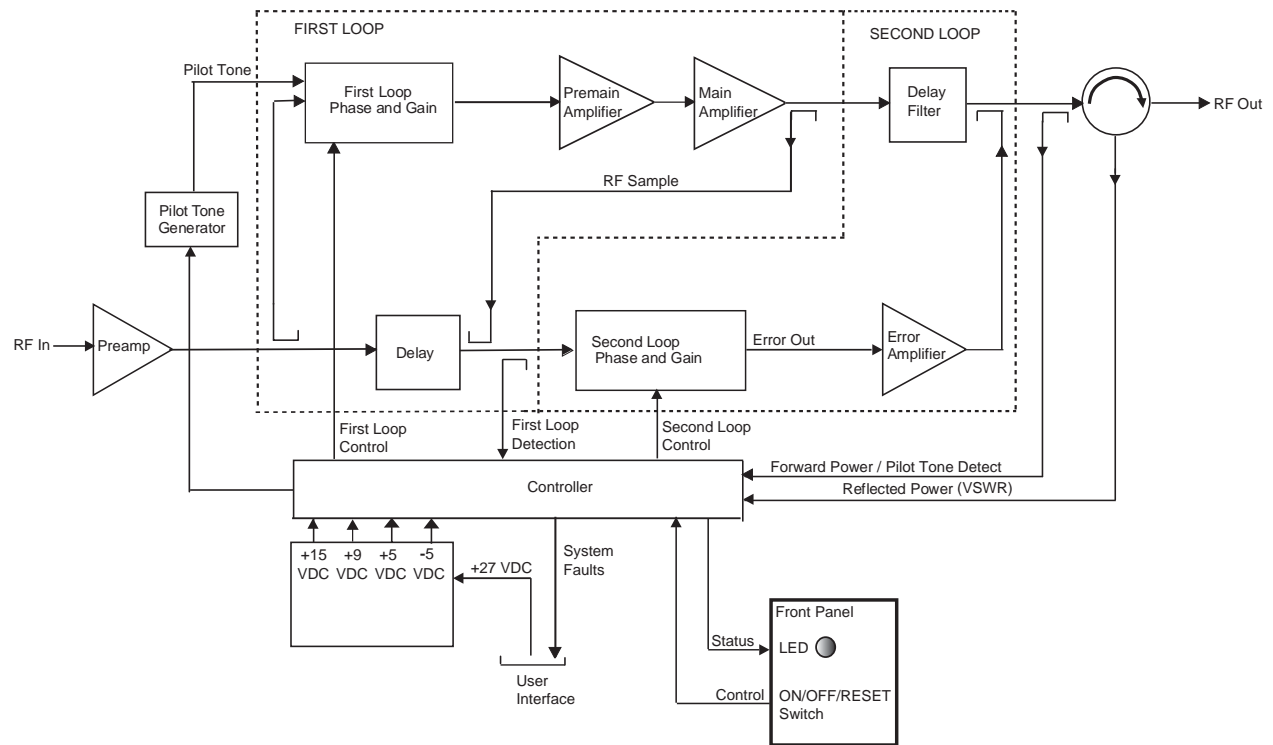

Figure 1-2 MCPA Functional Block Diagram

1.4.1 Preamplifier

The carrier (RF In) is applied to the input port of the MCPA and fed to the preamplifier stage where it is amplified using two stages of class A mode amplifiers. The output of the preamplifier is split into two paths, one to the main amplifier and one to the error amplifier.

1.4.2 Main and Error Amplifiers

The main amplifier provides the balance of gain and power in the 1930 MHz to 1990 MHz frequency band, using class AB amplification for maximum efficiency. The error amplifier and feed forward loops correct signal non-linearities introduced by the class AB main amplifier.

In the error amplifier, which operates in class A mode, the RF signal is coupled to an attenuator and phase shifter in the first feed-forward loop, phase shifted by 180 degrees and then amplified in the pre-main amplifier. The output from the pre-main amplifier is fed to the class AB main amplifier and then sampled using a coupler. The signal (RF sample) is combined with the main input signal and input to the second feed-forward loop.

There, the RF sample is attenuated, phase shifted 180 degrees, and fed to the error amplifier where it is amplified to a level identical to the sample output from the main amplifier. The output from the error amplifier (Error Out) is coupled back and added to the output from the main amplifier, with the control loops continuously making adjustments to cancel out any distortion in the final output signals.

1.4.3 Feed-forward Loop Control Circuits

The primary function of the first loop is to amplify the carrier signals and isolate an error signal for the second loop. It does this by amplifying the carrier signals and isolating an error signal which is passed to the second loop. The first loop control section phase shifts the main input signals by 180 degrees and constantly monitors the output for correct phase and gain.

The primary function of the second loop is to amplify the error signal to cancel out spurious products developed in the main amplifier. The input signal is amplified by a preamplifier and fed to a coupler and delay line. The signal from the coupler is fed to the attenuator and phase shifter in the first loop.

The second loop control section obtains a sample of the distortion added to the output signals by the main amplifiers. The signal is phase shifted 180 degrees, then fed to the error amplifier where it is amplified to the same power level as the input sample. The signal is then coupled to the main amplifier output. The final output is monitored by the second loop and adjusted to ensure that the signal distortion and intermodulation distortion on the final output is cancelled out.

During routine operation, all normal variations are automatically compensated for by the feed-forward loop control. If large variations occur beyond the adjustment range of the loop control, the controller shuts down the MCPA RF section and a loop fault is reported to the system.

1.4.4 Pilot Tone Generator

The pilot tone is an internally generated signal with a predetermined frequency, phase, and amplitude is known. If the pilot signal is suppressed at the amplifier output, then the distortion created by the main amplifier is also suppressed.

The pilot tone signal is injected into the first loop and detected at the feedforward output of the second loop. The pilot tone is coupled off of the main amplifier creating a second pilot tone that is attenuated and phase shifted 180 degrees to be used as the reference. The second pilot tone is amplified in the error amplifier and mixed with the signals from the main signal path.

The first and second pilot tones should cancel each other out in an ideal situation. If the output detector senses that the pilot tones do not cancel each other out, the information feeds back to control the gain and phase of both the main and error amplifier paths minimizing output distortion.

1.4.5 Controller

The controller constantly compares the active RF paths with internal references for dynamic correction of small variations through the RF feedback control circuits to maintain constant gain, and also provides the alarm monitoring and control for the MCPA.

A front panel mounted tri-color LED provides MCPA operational status to the local operator. The OFF/ON/RESET switch allows the operator to power on, power off or reset the MCPA. System faults are sent to a remote location through the user interface.

1.5 Cooling

The MCPA components are mounted on a heatsink and cooled by forced air flowing over the heatsink fins. System fans draw external air through the MCPA front panel inlet and exhaust air through the MCPA rear panel outlet. The internal temperature is monitored to keep the MCPA within the specified operating temperature.

1.6 Power Distribution

The host system provides +26 to 28 VDC power for the MCPA. The DC/DC converter and voltage regulator in the MCPA converts the +27 VDC to +15 VDC, +9 VDC, +5 VDC, and -5 VDC for internal use. The MCPA has no built-in short-circuit protection.

The MCPA operates at full power if the system DC supply is within 26 to 30 VDC. The MCPA shuts down if the applied DC power is less than 21.5 VDC or greater than 30.5 VDC.

This page intentionally left blank.

Chapter 2 Controls and Indicators

2.1 Introduction

This chapter contains descriptions of the G3L-1929-160 Multi-Carrier Power Amplifier (MCPA) controls and indicators.

2.2 MCPA Controls and Indicators

The location of the MCPA controls and indicators are illustrated in Figure 2-1 and listed with descriptions in Table 2-1.

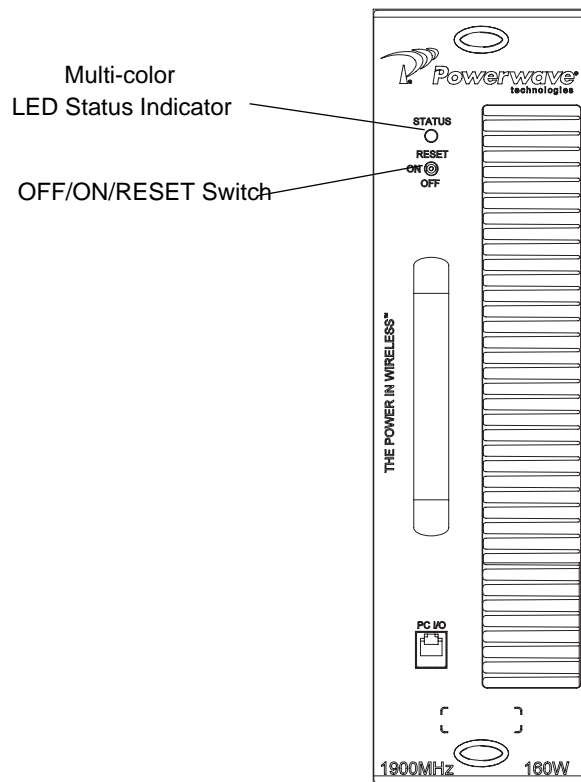

Figure 2-1 MCPA Controls and Indicators

2.2.1 MCPA Alarms

MCPA alarm conditions are reported to the system as logic level signals through the rear connector. The front panel LED provides a visual reference for the operator of MCPA status. Refer to Table 2-1 for a listing of LED states. Refer to Table 2-2 for a listing of Alarm states.

Table 2-1 MCPA Controls and Indicators

Controls and Indicators	Description
Toggle Switch, Three Position	
RESET (Up)	Resets MCPA. LED indicates boot mode (red), then turns solid green
ON (Center)	Enables MCPA. LED indicates solid green
OFF (Down)	Disables MCPA. LED Indicates solid red
LED, Status	
Green (solid)	RF enabled, OFF/ON/RESET switch set to On (center position), normal operation, no alarm
Green (blinking)	Standby
Yellow (solid)	Minor Alarm - APC function enabled
Yellow (blinking)	VSWR Warning
Red (solid)	Major alarm - Critical fault present.
Red/Yellow (alternating)	Downloading. Do not interrupt power.

Table 2-2 MCPA Alarm States

Alarm	Definition	Alarm type/LED	Auto-Recovery
Output Overpower	Disables MCPA immediately if output power is >+2 dB over rated output RF power.	Major (Red)	Input power decreases below APC threshold (-11.2 dBm)
Automatic Power Control (APC)	Enabled if output power is > 52.67 dBm.*	Minor (Yellow)	MCPA auto-recovers when output power drops below rated maximum output power.
Input Overdrive	Disables MCPA immediately if input RF drive is >-5 dBm	Major (Red)	Input power decreases below APC threshold (-11.2 dBm)
High Temperature	Disables MCPA if sensor temperature is > +95° C.	Major (Red)	MCPA auto-recovers when sensor temperature drops to less than +70 °C.
High Reverse Power	Disables MCPA if the reverse RF output power is higher than 49 dBm for a duration of 1-minute.	Minor (Yellow) during 1-minute validation period then changes to Major (Red)	Reverse power must be < 48.3 dBm.

Table 2-2 MCPA Alarm States (Continued)

Alarm	Definition	Alarm type/LED	Auto-Recovery
Exceed Maximum Voltage	Disables MCPA immediately if supply DC voltage > +30.5 VDC.	Major (Red)	Auto-recovery when supply voltage drops to < +29.5 VDC.
Below Minimum Voltage	Disables MCPA immediately if supply DC Voltage < +20.5 VDC	Major (Red)	Auto-recovery when supply voltage increases to >+24.0 VDC
Loop Fail (Linearization Alarm)	Disables MCPA if loop convergence fails.	Major (Red)	Auto-recovery when loop converges. MCPA tries to auto recover ten times before permanent shut down. Two minutes and 5 seconds for each try.
Internal DC Fail	Alarm if internal voltages fail or out of range.	Minor (None)	Auto-recovery once voltage is within range. No shutdown until linearization alarm occurs.
Device Fail	Alarm if one or more output power devices fail.	Minor (None)	No auto-recovery. No shutdown until linearization alarm occurs.

*Note: If MCPA cannot compensate gain to maintain compliance, Output Overpower or Input Overdrive faults protect MCPA.

2.2.2 MCPA Connectors

The MCPA power, alarm, control, and RF connections are made through a D-sub combination male interface connector located on the rear of the MCPA. Pin assignments are illustrated in Figure 2-2 and listed in Table 2-3. Alarms are interpreted and generated by the MCPA and reported to the base station as a system level alarm. The PC I/O RJ-11 connector is for factory use only.

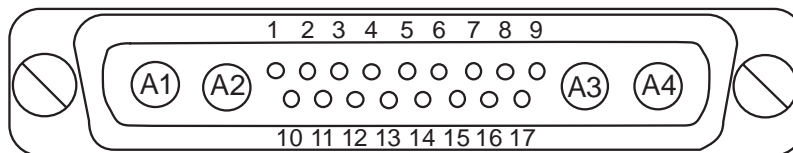

Figure 2-2 MCPA Interface Connector

Table 2-3 MCPA Connector Pinouts

Pin	Function	Pin	Function
A1	RF Input (Coaxial Contact)	8	Summary_Fault
A2	+27 VDC (Power Contact)	9	DC (On/Off)
A3	Ground (Power Contact)	10	System Reset TTL
A4	RF Output (Coaxial Contact)	11	NC
1	TX_H (RS-485)	12	NC
2	TX_L (RS-485)	13	AMP AO
3	GND	14	AMP A1
4	RX_H (RS-485)	15	AMP A2
5	RX_L (RS-485)	16	HPE
6	GND	17	NC
7	MOD_DET (Module Detection)		

Chapter 3 Installation

3.1 Introduction

This chapter contains unpacking, inspection, startup and installation procedures for the G3L-1929-160 Multi-Carrier Power Amplifier (MCPA).

- Review this chapter prior to equipment installation.
- Review any government and local codes applicable to this installation.
- Read the instructions in this Chapter and Chapter 4 before operating the equipment.

3.2 Unpacking and Inspection

Perform the steps in Table 3-1 to unpack and inspect the MCPA.

Table 3-1 MCPA Unpacking and Inspection Instructions

Step	Action
1	Carefully open container and remove MCPA.
2	Visually inspect MCPA for damage that may have occurred during shipment. Check for evidence of water damage, bent or warped chassis, loose screws or nuts, or extraneous packing material in connectors. If possible, inspect equipment in the presence of the delivery person.
3	If possible, retain all packing material that can be reused for repackaging components.

3.2.1 Damaged Equipment

If the MCPA is damaged, a claim should be filed with the carrier when the extent of any damage is assessed. Contact the factory for a return material authorization (RMA). Refer to Chapter 4 for the return procedure.

3.3 Air Conditioning Requirement

The MCPA generates 2770 BTUs of heat at 36 amps, 27 VDC and 160 watts average RF power output. The MCPA operates within the extended low temperature and high temperature environments as listed in Chapter 5.

3.4 MCPA Installation Instructions



CAUTION: Do not slam the MCPA into the system subrack during installation. Using excessive force can damage the MCPA interface connector.

The modular MCPA can be installed in a variety of systems. All system connections to the MCPA are made through the MCPA rear connector, no additional wiring is required. Perform the steps in Table 3-2 to install the MCPA. Refer to Figure 3-1 for quarter-turn fastener position and switch location.

Table 3-2 MCPA Installation

Step	Action
1	Set MCPA OFF/ON/RESET switch to the OFF (down) position.
2	Ensure quarter-turn fasteners are in unlocked position.
3	Lift and insert MCPA into the subrack. Turn the quarter-turn fasteners to locked position to secure MCPA into subrack.

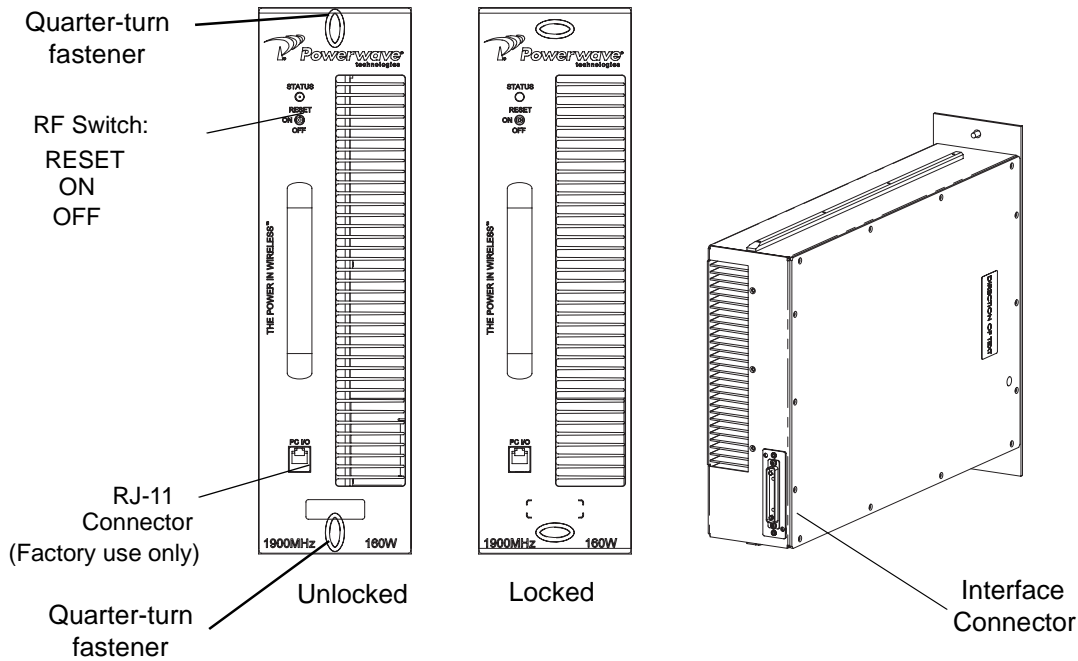

Figure 3-1 MCPA Quarter-turn fasteners and Connectors

3.5 Initial Start-up and Operating Procedures

Perform the MCPA initial start-up per the instructions in Table 3-3.



CAUTION: Before applying power, ensure input and output cables are properly terminated at the Duplexer front panel. Do not operate MCPA without a load attached. Excessive input power may damage the MCPA. Refer to Chapter 5 for input power requirements.

Table 3-3 Initial Start-up Procedure

Step	Action
1	Verify all system input and output cables are properly connected.
2	Verify +27 VDC (+/- 1 VDC) supply is available.
3	Set MCPA OFF/ON/RESET switch to ON (center) position.
4	Allow MCPA to warm-up for a minimum of two minutes before taking power readings.

This page intentionally left blank.

Chapter 4 Maintenance

4.1 Introduction

This chapter contains instructions for periodic maintenance, testing and troubleshooting for the G3L-1929-160 Multi-Carrier Power Amplifier (MCPA).

4.2 Periodic Maintenance

NOTE Check your sales order and equipment warranty before attempting to service or repair unit. Do not break seals on equipment under warranty or warranty will be null and void. Do not return equipment for warranty or repair service until proper shipping instructions are received from factory.

Periodic maintenance requirements for the MCPA are listed in Table 4-1.

Table 4-1 Recommended Periodic Maintenance

Task	Interval	Action
Cleaning	3 Months	Inspect for debris especially around front panel vents. Remove dust with a soft cloth/brush or vacuum cleaner
Performance tests	Optional	Perform testing in accordance with Paragraph 4.3.

4.3 MCPA Performance Tests

MCPA Performance tests are only performed at the factory. Refer to the troubleshooting instructions in Section 4.4.

4.4 Troubleshooting

Perform the instructions in Table 4-2 in the case of an MCPA fault or alarm.

Table 4-2 Troubleshooting

Step	Action
1	Check for proper DC supply voltage.
2	Set the OFF/ON/RESET switch momentarily to RESET (Up) position.
3	Contact your field representative or the factory if fault does not clear.

4.5 MCPA Removal and Replacement

Perform the instructions in Table 4-3 to remove and replace a MCPA.



CAUTION: Do not slam the MCPA into the system during installation. Using excessive force can damage the MCPA connector.



CAUTION: When removing the MCPA from the system, support the MCPA to prevent the rear of the MCPA from suddenly dropping when the guide rail disengages from the track. Dropping the MCPA can damage the rear multi-pin connector. The MCPA weighs approximately 28.60 lbs. (12.97 kg).

Table 4-3 MCPA Removal and Replacement

Step	Action
1	Set MCPA OFF/ON/RESET switch to OFF (down).
2	Loosen two quarter-turn fasteners that secure MCPA to the subrack.
3	With steady even pressure, use handle on front of the MCPA to pull the MCPA out of the system.
4	To replace MCPA, set MCPA OFF/ON/RESET switch to OFF (down).
5	Turn quarter-turn fasteners to Unlocked position.
6	Insert MCPA into subrack. Turn quarter-turn fasteners to locked position to secure MCPA.

4.6 Return For Service Procedures

When returning products to Powerwave, the following procedures will ensure optimum response.

4.6.1 Obtaining An RMA

A Return Material Authorization (RMA) number must be obtained prior to returning equipment and to reduce delays in receiving repair service. Please contact our Repair Department at (714) 466-1000 to obtain this number, or FAX your request to (714) 466-5816.

4.6.2 Repackaging for Shipment

To ensure safe shipment of a component, it is recommended that the original packing materials be reused. If this is not possible, use suitable shipping cartons and foam inserts to prevent damage in transit.

Chapter 5 Specifications

5.1 Multi-Carrier Power Amplifier Specifications

The performance and physical specifications for the G3L-1929-160 MCPA are listed in Table 5-1.

Table 5-1 MCPA Specifications

Electrical	Specifications/Features
Operating Frequency Band	1930-1990 MHz
Instantaneous Bandwidth	40 MHz
Air Interface	GSM, EDGE, CDMA, W-CDMA
RF Output Power	160 W (Min.) with seven GSM and one EDGE signal 150 W (Min.) with any combination of EDGE, GSM, W-DCDMA. Max. four EDGE, Max eight GSM/EDGE and MAX two W-CDMA signals 130 W (Min.) with Max. eight CDMA signals
Maximum Input (before shutdown)	-5 dBm
Duty Cycle	Continuous
BTUs	2770 at 36 Amps, 27 V and 160 W average RF power output
RF Gain	63 dB
Gain Flatness	±0.5 dB (Max.)
Gain Variation over Temperature	±0.5 dB (Max.)
Intermodulation Distortion	-62 dBc (Max.)
Harmonics	-13 dBm (Max.) 1 MHz Bandwidth; -50 dBc (Max.)
Out of Band Spurious	-60 dBc (Max) ITU-R, SM329-9, Category B
Input Return Loss	14 dB (Min.)
Output Return Loss	16 dB (Min.)
Input Voltage Range	+26 VDC to 28 VDC nominal; Operational range of 21.0 VDC to 30 VDC. MCPA disables at less than 20.5 VDC or greater than +30.5 VDC.
DC Current: (Max @ APC) (Nominal)	36 Amps at 26 V and 160 W average RF power output. 34.8 Amps at 27 V and 160 W average RF power output.
Efficiency	>17%

Table 5-1 MCPA Specifications (Continued)

Mechanical	Specifications/Features
Controls	Three position toggle switch: OFF/ON/RESET.
Alarm Indication	LED; Green (normal), Yellow (minor alarm), Red (Major alarm).
Platform Compatibility	Everest Power Amplifier (PA) will reduce power level to Harley/Python APC levels if placed in a Harley/Python subrack. PA will perform at rated power levels with Software upgrade for subrack.
RF Input / Output / Status / Alarm / Control / DC Input Connector	21-pin D-subminiature combo connector.
Dimensions	354.6 mm high, 99 mm wide, 499.9 mm deep (including handles) (13.96" H X 3.9" W X 19.7" D)
Weight	12.97 kg (28.5 lbs)
Environmental	Specifications/Features
Operating Temperature Range	-33 °C. to +50 °C.
Storage Temperature	-40 °C. to +70 °C.
Operating Humidity, Normal	5% to 95% relative humidity (non-condensing).
Storage Humidity	5% to 95% relative humidity (non-condensing).



Corporate Headquarters
Powerwave Technologies, Inc.
1801 East St. Andrew Place
Santa Ana, CA 92705 USA

Tel: 714-466-1000
Fax: 714-466-5800
www.powerwave.com

Main European Office
Antennvägen 6
SE-187 80 Tåby
Sweden
Tel: +46 8 540 822 00
Fax: +46 8 540 823 40

Main AsiaPacific Office
23 F Tai Yau Building
181 Johnston Road
Wanchai, Hong Kong
Tel: +852 2512 6123
Fax: +852 2575 4860