



AR Standard Repeater

Installation and Service Manual

044-05250 Rev A

February 2007



© 2007 Powerwave Technologies Incorporated. All rights reserved.

Powerwave Technologies and the Powerwave logo are registered trademarks.

Powerwave Technologies Inc. reserves the right to make changes to the documentation and equipment, including but not limited to component substitution and circuitry changes. Changes that impact this document may subsequently be incorporated in a later revision of this document.

This Powerwave product is designed to operate within the Normal Operating (typical operating) ranges or conditions specified in this document. Operation of this equipment beyond the specified ranges in this document may cause (1) spurious emissions that violate regulatory requirements; (2) the equipment to be automatically removed from service when maximum thresholds are exceeded; or (3) the equipment to not perform in accordance with its specifications. It is the Operator's responsibility to ensure this equipment is properly installed and operated within Powerwave operating specifications to obtain proper performance from the equipment and to comply with regulatory requirements.

Federal Communications Commission (FCC)

This equipment has been tested and found to comply with the limits for a Class A digital device, pursuant to part 15 of the FCC Rules. These limits are designed to provide reasonable protection against harmful interference when the equipment is operated in a commercial environment. This equipment generates, uses, and can radiate radio frequency energy and, if not installed and used in accordance with the instruction manual, may cause harmful interference to radio communications. Operation of this equipment in a residential area is likely to cause harmful interference in which case the user will be required to correct the interference at his own expense.

Industry Canadian Requirement

All Powerwave apparatus introduced on the Canadian market meet all requirements of the Canadian Interference-Causing Equipment Regulations.

Powerwave Technologies Inc., 1801 East St. Andrew Place, CA 92705 Santa Ana, USA.
Phone +1 714 466 1000 – Fax +1 714 466 5800 – Internet www.powerwave.com



Revision Record

Revision Letter	Date of Change	Reason for Change
3A	August 2005	Original VD203 66
A	February 2007	Document number changed to 044-05250 and manual updated

This Page Intentionally Left Bank

Table of Contents

Abbreviations	vi
-------------------------	----

Chapter 1 - Product Description

Introduction	1-1
Scope of Manual	1-1
Safety	1-1
Warning Signs	1-2
Human Exposure of RF Radiation	1-2
Repeater Antennas	1-2
Installation and Maintenance of Antenna Systems	1-2
Radiation Exposure	1-2
Radiation Safety Distances	1-3
Electrostatic Discharge (ESD)	1-4
Overview	1-5
Repeaters with RF / RF Transmission	1-5
Channel Selective (CSel) Repeater	1-5
Band Selective (BSel) Repeater	1-6
Repeaters with RF / Fiber Optic Transmission	1-6
Base Station Master Unit (BMU)	1-6
Repeater Master Unit (RMU)	1-6
Repeater with Fiber Optics / RF Transmission	1-6
Combined Repeater	1-6
Repeater Chassis Design	1-6
Sub Unit Overview	1-7
Channel Amplifier PCBA for GSM and EDGE (CHE)	1-7
CDMA/WCDMA Segment Amplifier PCBA (CSA)	1-7
Band Selective Amplifier PCBA (BSA)	1-7
Power Amplifier PCBA (PA)	1-7
Booster Amplifier (BA)	1-7
Distribution PCBA (DIA)	1-7
Control Unit PCBA (CU)	1-7
Directional Coupler (DC)	1-8
Low Noise Amplifier (LNA)	1-8
Duplex filter (DPX)	1-8
Fiber Optic Unit (FOU)	1-8
Fiber Optic Node (FON)	1-8
Power Supply Unit (PSU)	1-9
Remote Control Unit (RCU)	1-9
Combiner unit (CMB)	1-9
Alarm Interface PCBA (ALI) and Remote Control Interface PCBA (RCI)	1-9
Repeater-to-Repeater Interface Adapter (RIA)	1-9
Sub Unit Locations	1-9
CSel GSM Repeater	1-9
CSel CDMA/WCDMA Repeater	1-10
CSel High Power CDMA/WCDMA Repeater	1-10
BSel Repeater	1-11
BMU	1-11
RMU	1-12
FOR	1-12
Combined Repeater	1-13
Using Repeaters	1-13

Shaded Area	1-14
Sports Arena	1-15
Fiber Optic Distribution Networks	1-16
Multi-Operator Configurations	1-17

Chapter 2 - Controls, Connections and Indicators

Introduction	2-1
Front Cover LED Indicators	2-1
Cabinet LED Indicators	2-1
PCBA Connections	2-2
CHE PCBA	2-2
CSA PCBA	2-3
BSA PCBA	2-4
PA PCBA	2-4
BA PCBA	2-4
DIA – Distribution PCBA	2-5
DC	2-6
LNA	2-7
DPX	2-8
FOU	2-9
FON	2-10
PSU	2-12
Software and Hardware Compatibility	2-14

Chapter 3 - Installation

Introduction	3-1
Site Survey	3-1
Unpacking and Inspection	3-1
Repeater Location	3-1
Mounting	3-1
Connections	3-4
Main Power and Grounding	3-4
RF-to-RF Repeater Connections	3-5
BMU RF to Fiber Optic Connections	3-6
RMU RF to Fiber Optic Connections	3-7
FOR RF to Fiber Optic Connections	3-8
Optional Connections	3-9
Alarms	3-9
External Alarm	3-9
Door Open Alarm	3-9
Fiber Link Interface (FLI)	3-9
Wire Link Interface (WLI) Network (IP to R2R)	3-10
Main Power Breakdown Relay	3-11
21-60 Volt DC PSU Installation	3-12
Commissioning	3-13
Initial Startup	3-13

Chapter 4 - Maintenance

Introduction	4-1
Periodic Maintenance	4-1

Troubleshooting	4-1
Clearing Alarm Faults	4-1
Field Replaceable Units	4-9
FON	4-9
PSU	4-10
Repeater	4-10
Return For Service Procedures	4-11
Obtaining an RMA	4-11
Repackaging for Shipment	4-11
Options	4-11
Remote Control Unit (RCU)	4-11
RCU for Radio Communication	4-12
RCU for Telephone Line Communication	4-12
Previous RCU Version for GSM 900/1800/1900	4-12
GSM subscriber conditions	4-13
Power supply backup	4-13
Repeater-to-Repeater Link (R2R)	4-13
Protocol	4-14
Traffic Statistics	4-14
Battery Backup (BBU)	4-14
7/16" Antenna Cable Connectors	4-14
Operation and Maintenance System (OMS)	4-14

Chapter 5 - Specifications

Introduction	5-1
------------------------	-----

Appendix A - Block Diagrams

Introduction	6-1
CSel GSM Repeater	6-1
CSel CDMA/WCDMA Repeater	6-2
BSEL Repeater	6-3
BMU	6-4
RMU	6-5
FOR	6-6

List of Figures

1-1	Safety Distance to Active Antenna	1-4
1-2	Powerwave AR Standard Repeater	1-5
1-3	CU PCBA	1-8
1-4	CSel GSM Repeater Sub Unit Locations	1-9
1-5	CSel CDMA/WCDMA Repeater Sub Unit Locations	1-10
1-6	CSel High Power CDMA/WCDMA Repeater Sub Unit Locations	1-10
1-7	Band Selective Repeater Sub Unit Locations	1-11
1-8	BMU Sub Unit Locations	1-11
1-9	Optical Converter Module (OCM)	1-12
1-10	RMU Sub Unit Locations	1-12
1-11	FOR Sub Unit Locations	1-12
1-12	Combined Repeater Sub Unit Locations	1-13
1-13	Repeater Coverage of Shaded Area	1-14
1-14	Repeater in Sports Arena	1-15
1-15	Star Configuration Using One BMU and Four FORs	1-16
1-16	Daisy-chain Configuration Using One RMU and Four FORs	1-16
1-17	Multi-operator System	1-17
2-1	External Indicators	2-1
2-2	Cabinet Internal Indicators	2-1
2-3	DIA PCBA Connectors and Testpoints	2-5
2-4	Directional Couplers	2-6
2-5	Low Noise Amplifiers	2-7
2-6	FOU	2-9
2-7	FON LED Indicators	2-10
2-8	Power Supply Unit (PSU)	2-12
3-1	Mounting Bracket	3-2
3-2	Mounting Bracket Installation on Wall	3-2
3-3	Attaching the Bracket to a Pole	3-3
3-4	Attaching the Bracket to a Mast	3-3
3-5	Attaching the Repeater to the Bracket	3-4
3-6	RF-to-RF Repeater Connections	3-5
3-7	BMU RF-to-Fiber optic Connections	3-6
3-8	RMU RF-to-Fiber Optic Connections	3-7
3-9	FOR RF-to-Fiber Optic Connections	3-8
3-10	External Alarm Connection	3-9
3-11	IP and R2R Network Connection	3-10
3-12	RS-485 Cable Repeater	3-10
3-13	Main Power Breakdown Relay Connection	3-11
3-14	PSU Connections	3-12
3-15	Connecting a PC for Local Access	3-13
3-16	Output Signal Level Ports	3-14
4-1	RCU in the Repeater Cabinet	4-11
4-2	RCU - GSM 900 Type	4-12
4-3	R2R Network	4-13

List of Tables

2-1	LED Indicators	2-2
2-2	CHE PCBA Connectors	2-2
2-3	CSA PCBA Connectors	2-3
2-4	BSA PCBA Connectors	2-4
2-5	BA PCBA Connectors	2-4
2-6	DIA PCBA Connectors	2-5
2-7	Directional Coupler Connections	2-6
2-8	Low Noise Amplifier Connections	2-7
2-9	DPX Connections	2-8
2-10	FOU/DPX Connections	2-9
2-11	FON LED Indicators	2-10
2-12	FON Connectors	2-11
2-13	PSU Connectors	2-12
2-14	Hardware/Software Compatibility	2-14
3-1	RF-to-RF Connections Procedure	3-5
3-2	BMU RF-to-Fiber Connections Procedure	3-11
3-3	RMU RF-to-Fiber Connections Procedure	3-12
3-4	FOR RF-to-Fiber Connections Procedure	3-13
3-5	Main Power Breakdown Relay Connection	3-11
3-6	PSU Replacement Procedure	3-12
3-7	Initial Startup Procedure	3-13
4-1	Recommended Periodic Maintenance	4-1
4-2	Alarm Troubleshooting	4-1
4-3	FON Replacement Procedure	4-9
4-4	PSU Replacement Procedure	4-10
4-5	Repeater Replacement Procedure	4-10
5-1	AR Standard Repeater Specifications	5-1

Abbreviations

The following list of abbreviations are used throughout this manual, the software, and the repeater:

AGC	Automatic Gain Control
ALI	Alarm Interface
AMPS	Advanced Mobile Phone Service
BA	Booster Amplifier
BeO	Beryllium Oxide
BMU	Base Station Master Unit
BS	Base Station, BS antenna = towards the base station
BSA	Band Selective Amplifier
BSel	Band Selective
BTS	Base Transceiver Station
CDMA	Code Division Multiple Access
CHE	Channel Amplifier for GSM and EDGE
CMB	Combiner
CSA	Channel Selective Amplifier
CSel	Channel Selective
CU	Control Unit
CW	Continuous Wave
DAMPS	Digital Advanced Mobile Phone Service
DC	Directional Coupler
DCS	Digital Communication System (same as PCN)
DIA	Distribution Interface
DL	Downlink signal direction (from base station via repeater to mobile station)
DPX	Duplex filter
EDGE	Enhanced Data rates for GSM Evolution
EEPROM	Electrical Erasable Programmable Read Only Memory
EGSM	Extended Global System for Mobile communication
ESD	Electrostatic Discharge
ETACS	Extended Total Access Communication System
ETSI	European Telecommunications Standard Institute
FLI	Fiber Link Interface
FON	Fiber Optic Node
FOR	Fiber Optic Repeater
FOU	Fiber Optic Unit
GSM	Global System for Mobile communication
HW	Hardware
ICNIRP	International Commission on Non-Ionizing Radiation Protection
LED	Light Emitting Diode
LNA	Low Noise Amplifier
MS	Mobile Station, MS antenna = towards the mobile station
MSC	Mobile Switching Center
NEMA	National Electrical Manufacturers Association

NiCd	Nickel Cadmium
NMT	Nordic Mobile Telephone system
NOC	Network Operations Center
OCM	Optical Converter Module
OMS	Operation and Maintenance System
PCN	Personal Communication Network (same as DCS)
PCS	Personal Communication System
POI	Point of Interconnect
PSM	Power Supply Module
PTFE	Polytetrafluoro Ethylene (Teflon)
R2R	Repeater-to-Repeater
RCI	Remote Control Interface
RCU	Remote Control Unit
RCM	RF Converter Module
RF	Radio Frequency
RIA	Repeater-to-Repeater Adapter
RMU	Remote Master Unit
RSSI	Received Signal Strength Indication
RTC	Real Time Clock
SW	Software
TACS	Total Access Communication System
TDMA	Time Division Multiple Access
UL	Uplink signal direction (from mobile station via repeater to base station)
UPS	Uninterruptible Power Supply
WHO	World Health Organization
WLI	Wire Link Interface

This Page Intentionally Left Blank

Chapter 1

Product Description

Introduction

This manual contains information and procedures for installation, operation, and maintenance of the AR Standard Repeater.

Scope of Manual

This manual is intended for use by service technicians familiar with similar types of equipment. It contains service information required for the equipment described and is current as of the printing date. Changes which occur after the printing date may be incorporated by a complete manual revision or alternatively as additions. The manual is organized into chapters as follows.

- Chapter 1 - Product Description
- Chapter 2 - Controls, Connections and Indicators
- Chapter 3 - Installation
- Chapter 4 - Maintenance
- Chapter 5 - Specifications

Safety

It is necessary that any personnel involved in installation, operation or service of units included in a Powerwave repeater system understand and follow the below points.



- Powerwave repeaters are designed to receive and amplify signals from one or more base stations and retransmit the signals to one or more mobile stations. And, also to act the other way round, that is to receive signals from one or more mobile stations, amplify and retransmit the signals to the base stations. Powerwave repeater systems must be used exclusively for this purpose and nothing else.
- Units supplied from the mains must be connected to grounded outlets and in conformity with the local prescriptions.
- Power supply units supplied from the mains contain dangerous voltage that can cause electric shock. Disconnect the mains prior to any work in such a unit. Local regulations are to be followed when servicing such units. Authorized service personnel only are allowed to service units while the mains is connected.
- The repeater cover must be secured in opened position, for instance by tying it up, at outdoor repeater work. Otherwise, the cover can be closed by the wind and cause your fingers getting pinched or your head being hit.
- When working on a repeater on high ground, for instance on a mast or pole, be careful not to drop parts or the entire repeater. Falling parts can cause serious personal injury.
- All RF transmitting units, including repeaters, will generate radio signals and thereby give rise to electromagnetic fields that may be hazardous to the health of any person who is extensively exposed close to an antenna.
- Beryllium oxide (BeO) may be contained in power devices, for instance in dummy loads in directional couplers (DCC), in combiner units (CMB), and in attenuators on the FON board. Beryllium oxide is poisonous if present as dust or smoke that can be inhaled. Do not file, grind, machine, or treat these parts with acid.
- Coaxial cables used in many Powerwave systems have the insulation made of PTFE, polytetrafluoro ethylene, that gives off small amounts of hydrogen fluoride when heated. Hydrogen fluoride is poisonous. Do not use heating tools when stripping off

coaxial cable insulation. No particular measures are to be taken in case of fire because the emitted concentration of hydrogen fluoride is very low.



- A lithium battery is permanently mounted in repeater CU units, and in FON and OCM units. Due to the risk of explosion, this battery must only be removed from the board by an Powerwave authorized service technician.



- NiCd batteries are mounted on the FON unit. These batteries contain environmental poisonous substances. If replaced, the old batteries should be taken care of as stated in the local prescriptions.

- The FON unit contains a class IIIb laser transmitter that emits 2 – 4mW invisible laser radiation during operation. Avoid direct exposure from unconnected laser transmitter or fiber cord as follows:

– Do not power up the FON unit if a fiber cable is not attached to the fiber output UL port, neither if a fiber cable is attached to the port but unattached in the other end.

– **Never look in the end of a fiber cable.** The 1310nm and 1550nm laser light is not visible, so no signal identification can be made anyway. Use always an instrument, such as a power meter to detect signaling.

– **Never use any kind of magnifying devices that can focus the laser light to an unaided eye.**

Warning Signs



The following warning signs must be observed and be kept clean and readable. The warning sign to the left is applied on boards and units which contain beryllium oxide parts. The warning sign below is applied at the bottom, inside the cabinet, below the power supply unit.

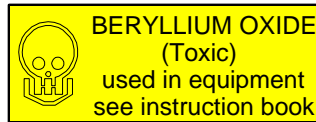

Human Exposure of RF Radiation

Safe distances must be kept when working around antennas. The following paragraphs describe the cautions to be aware of during the installation and maintenance of antenna systems and how to calculate safety distances needed for RF radiation at different antenna power and frequencies.

Repeater Antennas

To be able to receive and transmit signals, a repeater is connected to a donor antenna directed towards the base station and a service antenna directed towards the coverage area. A fiber optic cable from the base station might, however, be substituted for the donor antenna.

Installation and Maintenance of Antenna Systems

Installation and maintenance of all repeater antenna systems must be performed with respect to the radiation exposure limits for public areas. The antenna radiation level is affected by repeater output power, antenna gain, and transmission devices such as cables, connectors, splitters and feeders. Also have in mind the system minimum coupling loss, typically between 25dB and 35dB, is determined by a standard with the purpose to protect base stations from noise and other performance dropping effects.

Radiation Exposure

The World Health Organization (WHO) and International Commission on Non-Ionizing Radiation Protection (ICNIRP) have determined recommendations for radiation exposure. ICNIRP recommends not to exceed the following radiation power for public exposure:

Frequency	Radiation power
900MHz	4.5W/m ²
1800MHz	9.0W/m ²
2100MHz	10.0W/m ²

For antennas larger than 20cm the maximum radiation power can be calculated by using the following formula:

$$S = \frac{P}{4 \times \pi \times r^2}$$

where S = Radiation power in W/m²

P = Output power in W

r = Distance between antenna and human in meter

To tackle the worst case successfully, the calculation does not consider system power reducing actions, such as power control and DTX. Figure 1-1 shows the safety distance to an antenna due to the RF radiation. The distance depends on antenna output power and frequency, which is illustrated with the two graphs. One graph applies to 4.5W/m² (900MHz) and the other to 9.0W/m² (1800MHz) or 10.0W/m² (2100MHz). The safety distance range is 0 to 1.4 meters which covers an antenna power range of 10dBm to 50dBm (0.01W to 100W).

Radiation Safety Distances

This section illustrates the safety distances to the antennas for some typical repeater configurations.

Outdoor GSM 900MHz

Repeater output power	+33dBm
Feeder loss	-5dB
Antenna gain	+17dBi
Equivalent Isotropic Radiated Power (EIRP)	+45dBm

The safety distance can be read to 0.75 meter in Figure 1-1 as the maximum radiation power is 4.5W/m² for 900MHz.

Indoor GSM 900MHz

Repeater output power	+22dBm
Feeder loss	-5dB
Antenna gain	+1dBi
EIRP	+18dBm

The safety distance can be read to 0.035 meter for 4.5W/m² (900MHz).

Outdoor UMTS Standard High Power

Repeater output power	+38dBm
Feeder loss	-5dB
Antenna gain	+17dBi
EIRP	+50dBm

The safety distance can be read to 0.9 meter for 10W/m² (2100MHz).

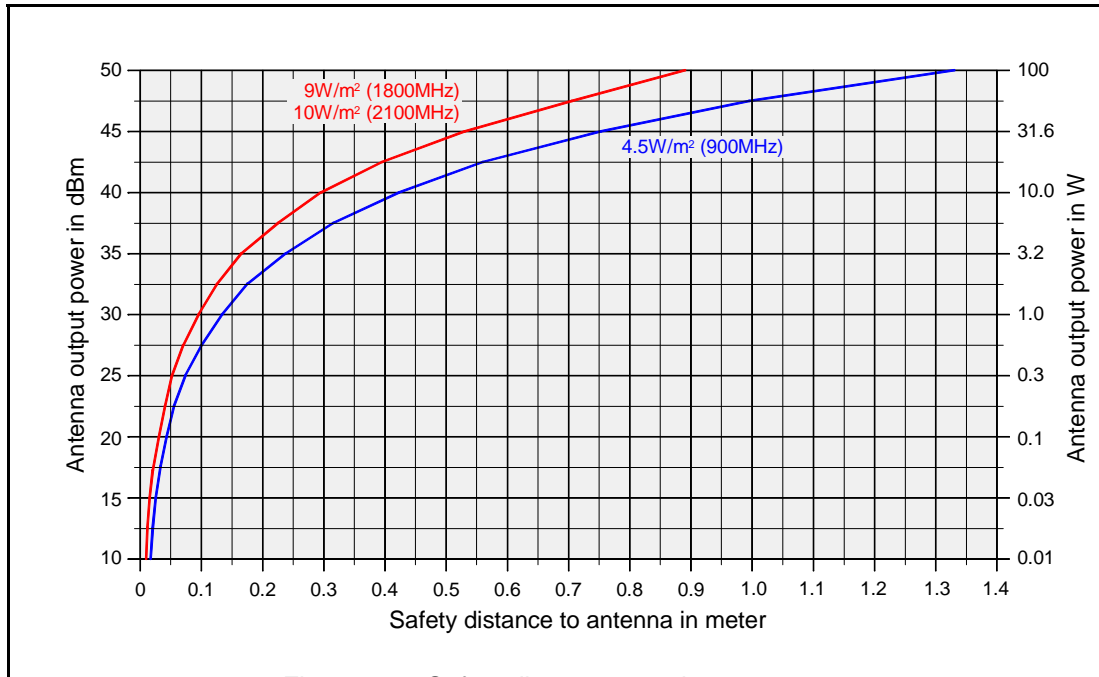

Figure 1-1 Safety distance to active antenna.

Indoor UMTS

Repeater output power	+24dBm
Feeder loss	-5dB
Antenna gain	+3dBi
<hr/>	
EIRP	+22dBm

The safety distance can be read to 0.035 meter for 10W/m² (2100MHz).

Electrostatic Discharge (ESD)



ESD can severely damage essential parts of the equipment if not handled carefully. Parts on printed circuit board assemblies (PCBA) as well as other parts in the equipment are sensitive to ESD. Never touch the PCBA or uninsulated conductor surfaces unless absolutely necessary.

If you must handle the PCBAs or uninsulated conductor surfaces, use ESD protective equipment or first touch the chassis with your hand. Never let your clothes touch PCBAs or uninsulated conductor surfaces and always store PCBAs in ESD-safe bags.

Overview



Figure 1-2 Powerwave AR Standard Repeater

Powerwave AR repeaters work as bi-directional on-frequency amplifiers used to fill out uncovered areas in wireless mobile systems such as base station fringe areas, tunnels, business, convention centers, airports and industrial buildings.

A repeater receives, amplifies and transmits signals to/from a base station to/from mobile stations with both directions being served simultaneously. To be able to receive and transmit signals in both directions, a repeater is connected to a donor antenna directed towards the base station and to a service antenna directed towards the area to be covered. These antennas are connected to the repeater with N type or 7/16" male connectors. The repeaters can also be connected via RF cables or fiber optic cables instead of donor or service antennas.

Powerwave repeaters are microprocessor controlled with alarm and operational status LEDs visible on the front cover. Cooling is provided through convection heat dissipation. To prevent instability due to poor antenna isolation, a built-in antenna isolation supervision feature reduces the gain level automatically when poor antenna isolation is detected.

Operational parameters, such as gain, channel number and power levels are set using a PC running Powerwave OM-Online software which can communicate with the repeaters either locally or remotely via modem. Remote operation can be performed via PSTN or a GSM net. The Operation and Maintenance System (OMS) provides for Network Operations Center (NOC) configuration and alarm monitoring.

AR repeaters can be configured in many combinations, depending on the wireless system, single or double system operation, RF or optical transmission, and output power. The most common types of the AR repeaters are described in the following sections. Since all of the repeater models can be configured differently, the descriptions are applicable only to a small portion of the most commonly configured repeaters.

In this document, the channel selective 900, 1800, and 1900 systems are called GSM, DCS and PCS respectively even though these systems may have different names in other parts of the world.

Repeaters with RF / RF Transmission

All units depicted on this and the following pages are assumed to have the donor connection to the left and the service connection to the right.

Channel Selective (CSEL) Repeater

A channel selective GSM repeater is used for channel selective systems such as GSM, DCS, and PCS. It can be equipped with up to four channels in a standard chassis and up to eight in

a high cover chassis. This repeater type has the ability to work with GSM (GMSK) and EDGE (8PSK) in GSM and PCS systems. AR17xx, AR27xx, and AR37xx are EDGE compatible.

A channel selective CDMA or WCDMA repeater is used for digital code division systems in accordance with IS-95 (CDMA 2000 – 3GPP2) for CDMA and 3GPP / UMTS for WCDMA or J-STD-008 standard, and wideband digital code division systems. It can be equipped with two channels in the cabinet and additional two channels in a high cover. It can be connected with either a donor antenna or RF cable and a service antenna or RF cable.

Channel selective High Power CDMA/WCDMA repeaters are the same as the CDMA/WCDMA repeaters but are equipped with a 6dB (typically) Booster Amplifier (BA) in the downlink path. The BA is located in the high cover with its own PSU and reduces the number of channels to two in the cabinet.

Band Selective (BSel) Repeater

The band selective repeater has an adjustable bandwidth and is used for analog or digital systems such as GSM, TACS, ETACS, AMPS, DAMPS, CDMA and WCDMA. This repeater type can be equipped with one band in the cabinet and additional one band in a high cover. It can be connected with either a donor antenna or RF cable and a service antenna or RF cable.

Repeaters with RF / Fiber Optic Transmission

Base Station Master Unit (BMU)

A BMU is equipped with a Fiber Optic Node (FON) for optical transmission on the service side. It has an RF port for BTS connection and can provide up to four fiber optic ports that can be connected to Fiber Optic Repeaters (FORs) and WRHs by using WDMs and splitters. FORs and WRHs can be fed in parallel with double or single fiber optic cables. Up to eight FORs and WRHs can be fed if the BMU is equipped with a high cover and two FONs. The BMU is also available as a 19" rack mounted unit called an Optical Conversion Module (OCM). Information on the OCM is located in the *Fiber Optic Equipment User Manual (044-052530)*.

Repeater Master Unit (RMU)

An RMU is a repeater equipped with a FON for optical transmission on the service side. The RMU has an RF port for a donor antenna and provide up to four fiber optic ports that can be connected to FORs and WRHs by using WDMs and splitters. FORs and WRHs can be fed in parallel with double or single fiber optic cables. Up to eight FORs and WRHs can be fed if the BMU is equipped with a high cover and two FONs.

Repeater with Fiber Optics / RF Transmission

A FOR is a repeater equipped with a FOU for optical transmission on the donor side. The FOR can connect to either a service antenna or RF cable. The FOR has a fiber optic donor port and an RF port for a service antenna (or RF cable). This unit can be connected to a BMU or RMU.

Combined Repeater

Some of the repeater types mentioned above can be combined in the same repeater chassis and be in operation in parallel. This can be used for different systems or different operators. One repeater part is located in the cabinet and an additional repeater part is located in a high cover. A combined repeater can, for example, have two RF ports for donor antennas (or RF cables) and two RF ports for service antennas (or RF cables).

Repeater Chassis Design

The repeater is housed in a cast aluminium waterproof chassis, class NEMA4 / IP65 approved for outdoor use but is also suited for indoor installations. The chassis consists of a cabinet and a cover attached with hinges. The cabinet contains the repeater circuitry. The cover comes as either a low or high version. The high cover can be used as an empty cover or be equipped as a part of the repeater or an independent repeater unit. A repeater with a high cover that is equipped as two independent repeater units (combined repeater) can, for example, be equipped for channel selective operation in the cabinet and band selective operation in the cover.

Sub Unit Overview

A number of amplifier boards are individually shielded and located under a metal cover inside the repeater. This cover can be opened outward for access. These amplifier PCBAs are of different types depending on the supported system. All of the repeater types are built up with a number of sub units which are described in the following paragraphs.

Channel Amplifier PCBA for GSM and EDGE (CHE)

The CHE is used for CSeI operations. CSeI GSM repeaters can handle up to eight channels. For every even number of channels, two CHEs are required, one for the uplink and one for the downlink. Numbered from left to right, positions 1 and 2 are used for two DL CHEs and 3 and 4 for two UL CHEs. Each repeater channel is allocated to a radio channel or switched off. In a GSM system, each repeater channel can handle eight calls (sixteen if half-rate encoding is used).

CDMA/WCDMA Segment Amplifier PCBA (CSA)

CSeI CDMA/WCDMA repeaters can handle two CDMA or WCDMA repeater channels. The CSA provides this capability. For every even number of channels, two CSAs and two PAs are required; one pair of CSA/PAs for the uplink and one pair for the downlink. Each repeater channel is allocated to a radio channel or switched off. Numbered from left to right, position 1 is used for a CSA, position 2 for a DL PA, position 3 for a CSA and position 4 for a UL PA.

Band Selective Amplifier PCBA (BSA)

The BSA is used for BSeI operations. BSeI repeaters can handle multi-carriers over a wide band through the use of an adjustable bandwidth. Each repeater band requires two BSAs and two PAs; one pair of BSA/PAs for the downlink and one pair for the uplink. Numbered from left to right, position 1 is used for a DL BSA, position 2 for a DL PA, position 3 for an UL BSA and position 4 for an UL PA.

Power Amplifier PCBA (PA)

The PA is used to amplify the output signal from a BSA and a CSA. Each PCBA contains one path that can be used for either DL or UL amplification. Two PAs are thus required for one band for the downlink and uplink.

Booster Amplifier (BA)

CDMA/WCDMA repeaters can be equipped with a BA on the DL path to boost the output gain by 6dB (typically). The BA can operate with a maximum of 2 channels and occupies position 3 in the cabinet and position 7 in a high cover. It also requires an extra heat sink element on the outside of the cabinet or high cover. Some configurations use the existing PSU while others require a second PSU.

Distribution PCBA (DIA)

The DIA is a distribution PCBA on which all other PCBAs and units are connected to in the cabinet. A shielded metal frame on the DIA provides the mounting location for the CU, ALI and RCIs, if used.

Control Unit PCBA (CU)

The CU PCBA, illustrated in Figure 1-3, is the core microprocessor controller PCBA in the AR repeater and connects to port P2 on the DIA. It contains a microprocessor, main memory, flash memory for the CU software, EEPROM memory for parameters, memory for the event log and statistics, a REFO reference oscillator, ports for local and remote communication, battery powered real-time clock, and MAC identity circuit.

The CU supervises and controls operational parameters such as gain control and channel handling, alarms, event log, password and logon. It is also a control interface for OM-Online and OMS. Software for the CU can be downloaded from OM-Online, either locally or remotely, or from OMS.

CU PCBAs from part # K103/3 handle R2R communications which means the RIA is not required for R2R network. The CU is located in the lower right part of the shielded DIA frame. LED indicators are described in Chapter 2.

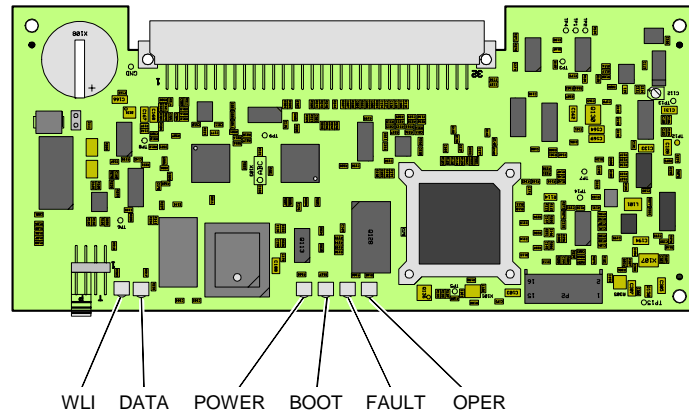

Figure 1-3 CU PCBA

Directional Coupler (DC)

DC units are used as antenna signal directional couplers. They are located on the left and right side in the lower part of the cabinet if a test port (TEST –30 dB) or an antenna port (MS –20 dB) for an internal RF modem is required. Some repeater configurations lack a DC in the DL, UL or both directions.

Low Noise Amplifier (LNA)

LNAs are used as uplink and downlink low noise branch amplifiers. They are located in the upper part of the cabinet or in equipped high covers. LNA/UL is located to the left and LNA/DL to the right. Some repeater configurations lack LNAs in the DL, UL or both directions.

Duplex filter (DPX)

DPXs are located on the cover plate over the amplifier boards.

Fiber Optic Unit (FOU)

The FOU is an add-on unit for the various repeater models. In the simplest form, the FOU is a metal plate on which a FON PCBA, a DPX and fiber optic connectors are assembled. It can also be configured with combiners, splitters and WDMs to obtain a desired combination of several branches with double or single fiber. The FOU is used in the BMU, RMU and FOR and is mounted on top of the cover plate in the upper part of the repeaters.

Fiber Optic Node (FON)

The FON is a bi-directional electrical/optical signal converter and a node in either a wire network or a fiber network. It has functionality for:

- Electrical and optical signal supervision
- Internal and external alarm handling
- RS232 interface for local PC control via an O&M software (OM-Online)
- Remote control via an O&M software (OM-Online or OMS)
- Interface for RCU
- Interface for WLI, wire network
- Interface for FLI, fiber optic network
- Battery backup with charger

The FON can be installed in all Powerwave repeaters

Power Supply Unit (PSU)

A PSU is located in the lower center of the cabinet and, if configured, in the lower center of the high cover.

Remote Control Unit (RCU)

The RCU is an optional communication unit for remote control of repeaters via PSTN or RF modems. RCU types and details are described on page 4-11.

Combiner unit (CMB)

CMB combiner units are used to combine two different bands. CMB units are located on the cover plate over the amplifier boards.

Alarm Interface PCBA (ALI) and Remote Control Interface PCBA (RCI)

The ALI handles alarms and alarm communication. It is replace with an RCI if an RCU is used and provides an interface between the CU and an RCU for remote communication via modem. The RCI also handles alarms and alarm communication. Either unit is located in the lower left part of the shielded DIA frame.

Repeater-to-Repeater Interface Adapter (RIA)

The RIA is required for R2R networking if a previous CU PCBA (K103/2), is used. This PCBA is located in the upper left part of the shielded DIA frame. R2R functionality is included starting in the CU PCBA part # K103/3.

Sub Unit Locations

The following sections describe the sub unit locations of the different models of AR Repeater and distribution units.

CSel GSM Repeater

A cabinet for a CSel GSM repeater can be equipped with four CHEs, two for the downlink (DL) with two internal channels each and two for the uplink (UL) with two internal channels each. The described cabinet has a capacity of four bi-directional GSM channels. A high cover can be equipped as well providing up to eight GSM channels. PCBA positions are illustrated in Figure 1-4 and a block diagram is located in Appendix A.

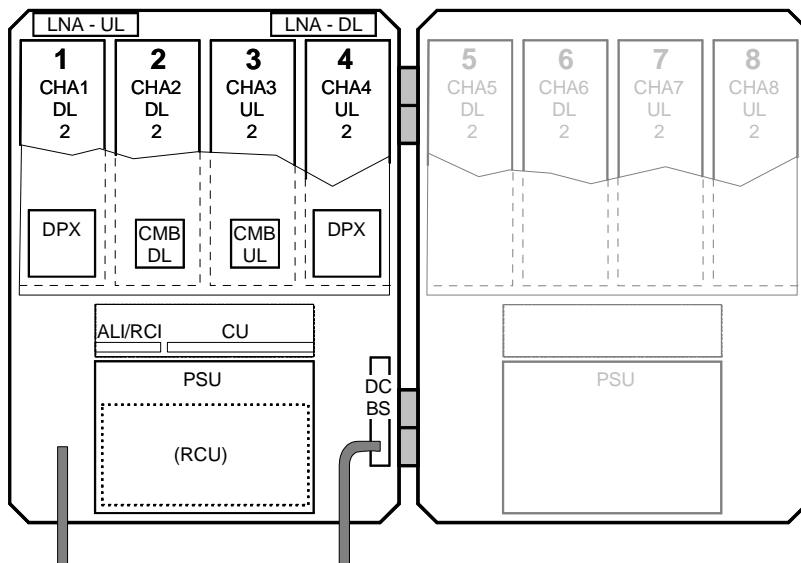

Figure 1-4 CSel GSM Repeater Sub Unit Locations

CSeI CDMA/WCDMA Repeater

A cabinet for a CSeI CDMA or WCDMA repeater can be equipped with two pair of CSAs and PAs, one pair for the DL and one pair for the UL. The described cabinet has a capacity of two bi-directional CDMA or WCDMA carriers. A high cover can be equipped as well providing up to four CDMA or WCDMA channels. PCBA positions are illustrated in Figure 1-5 and a block diagram is located in Appendix A.

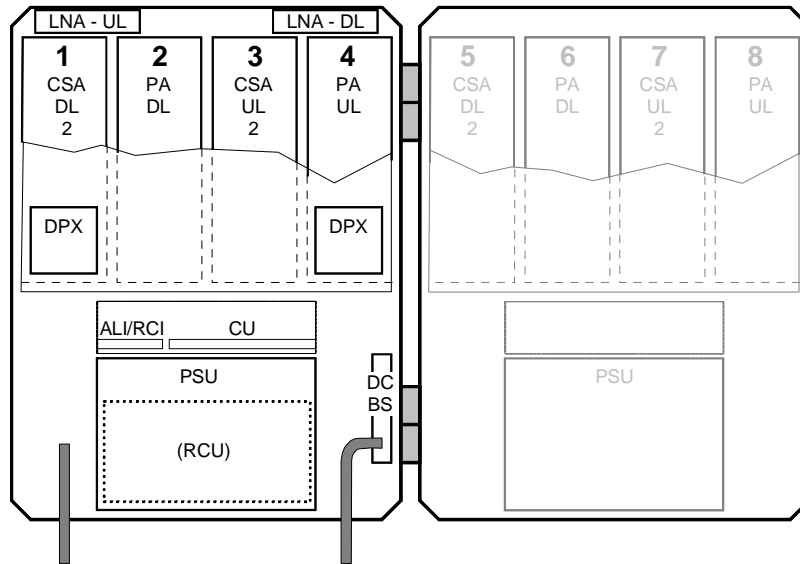

Figure 1-5 CSeI CDMA/WCDMA Repeater Sub Unit Locations

CSeI High Power CDMA/WCDMA Repeater

A cabinet for a CSeI High Power CDMA or WCDMA repeater can be equipped with two pair of CSAs and PAs, one pair for the DL and one pair for the UL. The described cabinet has a capacity of two bi-directional CDMA or WCDMA carriers. A high cover is equipped with the BA and an extra heat sink element on the outside of the cover. PCBA positions are illustrated in the Figure 1-6 and a block diagram is located in Appendix A.

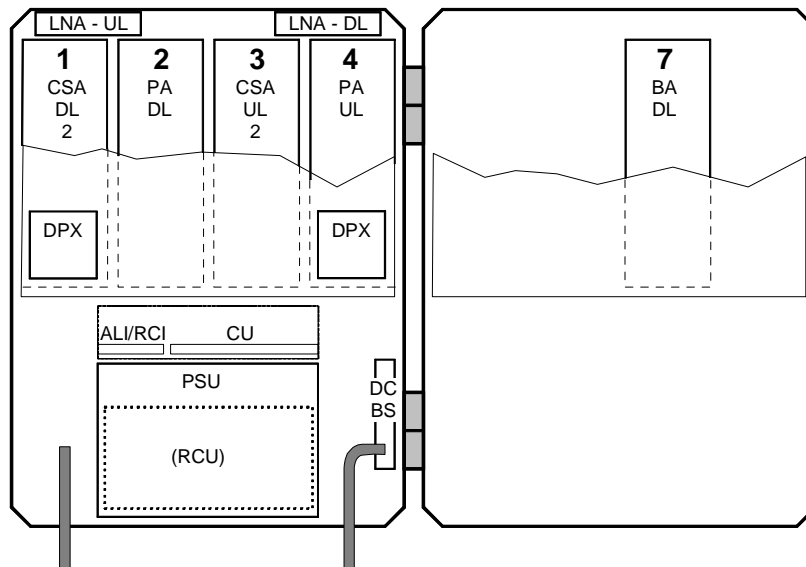

Figure 1-6 CSeI High Power Repeater Sub Units Locations

BSeI Repeater

A cabinet for a band selective repeater is equipped with two pairs of BSAs and PAs, one pair for the DL and one pair for the UL. The described cabinet is equipped for bi-directional band selective operation. A high cover can be equipped as well providing two bands. PCBA positions are illustrated in the Figure 1-7 and a block diagram is located in Appendix A.

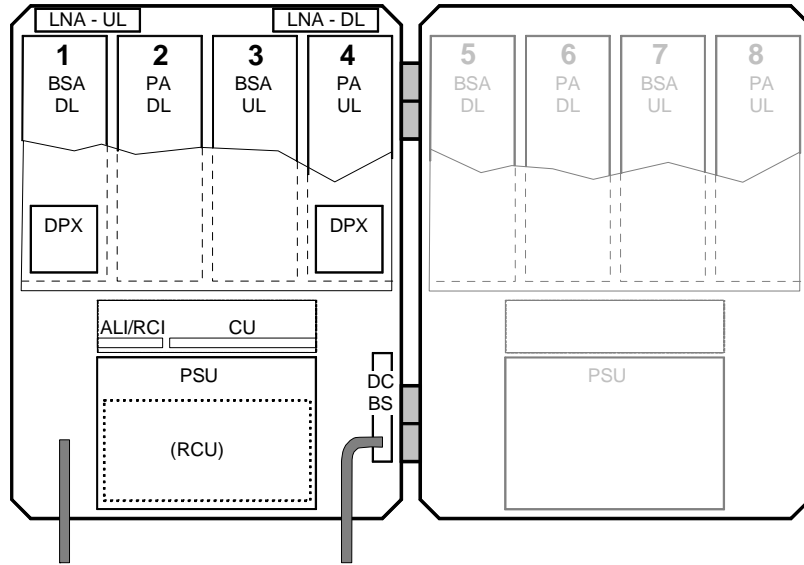

Figure 1-7 BSeI Repeater Sub Unit Locations

BMU

The BMU has the donor and service cable ports opposite the ports of other repeaters. A cabinet for a BMU has no CU PCBA and no amplifier PCBAs but instead contains a FOU with a FON and a DPX. By adding WDMs and splitters to the FOU, up to four FORs can be fed in parallel by a BMU with double or single fiber communication. A high cover can be equipped as well providing connections for up to eight FORs. PCBA positions are illustrated in the Figure 1-8 and a block diagram is located in Appendix A. The most common unit used to get the BMU functionality is the 19" indoor rack mounted OCM illustrated in Figure 1-9. The OCM is described in the Fiber Optic Equipment Operation and Maintenance Manual.

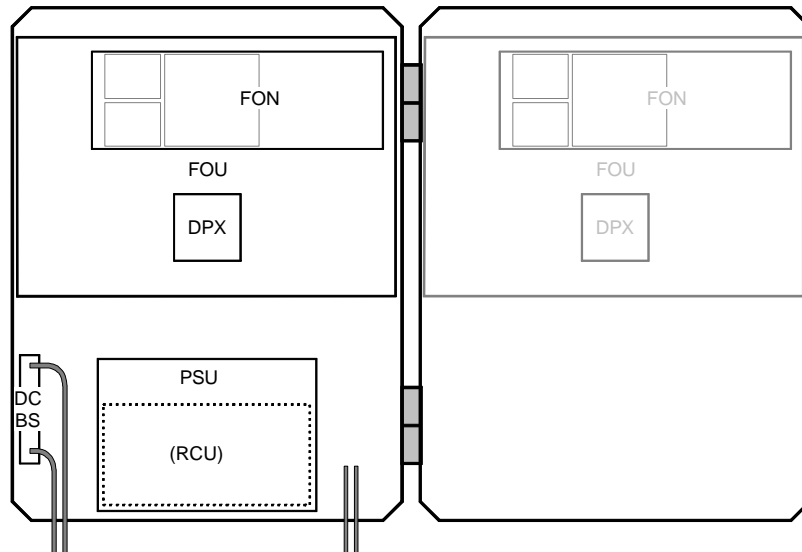

Figure 1-8 BMU Sub Unit Locations

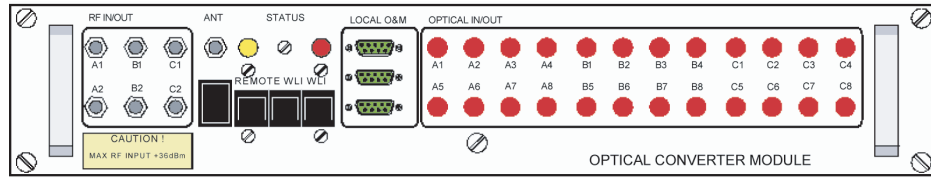

Figure 1-9 Optical Converter Module (OCM)

RMU

Figure 1-10 illustrates an example of an RMU for BSeI operation. This unit has a FON and a DPX. By adding WDMs and splitters to the FOU up to four FORs can be fed in parallel by a BMU with double or single fiber communication. A block diagram is located in Appendix A.

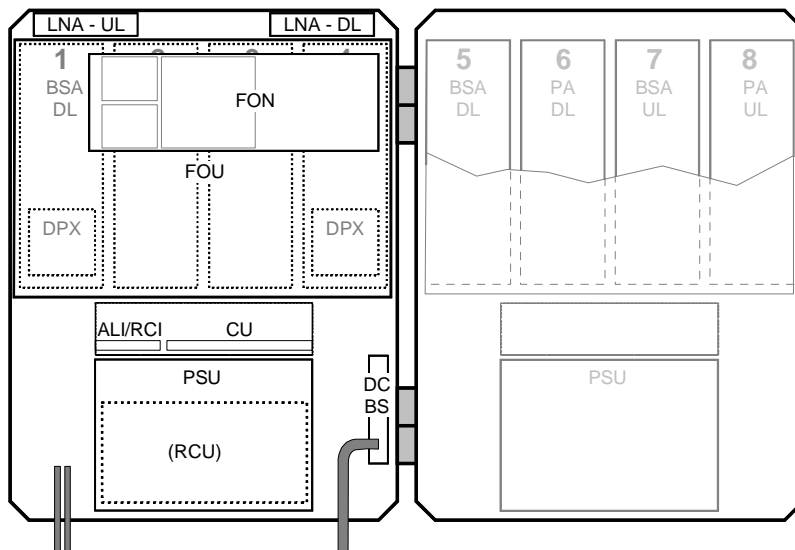

Figure 1-10 RMU Sub Unit Locations

FOR

Figure 1-11 illustrates an example of a FOR for band selective operation. This unit has a FON and a DPX.

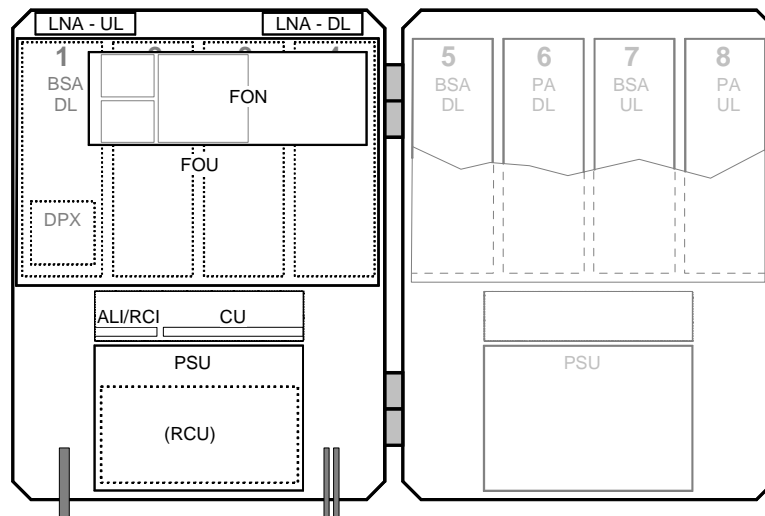

Figure 1-11 FOR Sub Unit Locations

Combined Repeater

Figure 1-12 illustrates a combined CSeI and BSeI repeater. The CSeI part is located in the cabinet and the BSeI part in a high cover. This example has four bi-directional GSM channels and BSeI operation. Most of the repeater models mentioned in this manual can be mixed as a combined repeater.

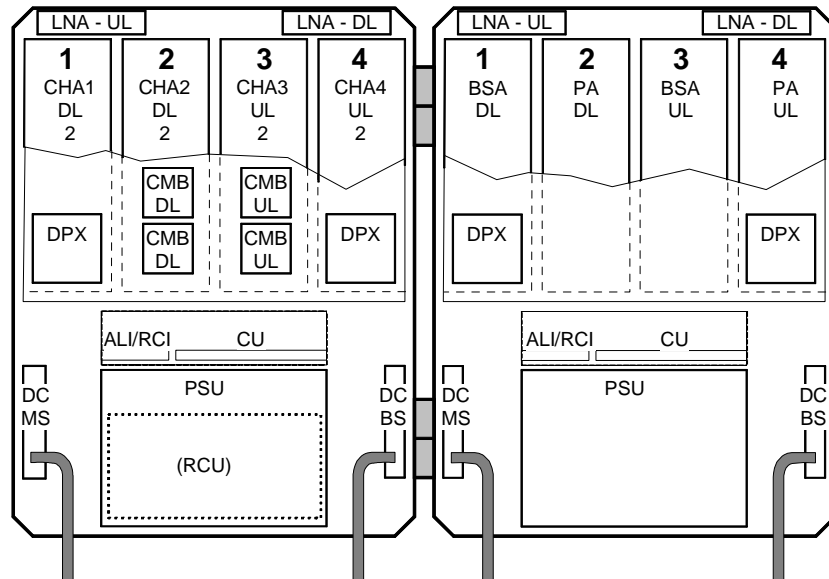

Figure 1-12 Combined Repeater Sub Unit Locations

Using Repeaters

In areas where the radio signal propagation is poor, repeaters can be used to fill out those areas which are not covered by the base station. Examples include:

- Sports arenas
- Fair halls
- Large shopping centres
- Road and railway tunnels
- Indoors in buildings with metal or concrete walls
- Other examples where repeaters can be used to increase the coverage are:
- Shaded areas
- Fringe coverage areas

In areas where the traffic intensity is low it is not cost efficient to install a base station, so the use of a repeater is a better, more cost effective option. Two examples are described in the following paragraphs: a shaded valley and an indoor sports arena.

Shaded Area

In this example, we have a valley that is shaded by the hills surrounding it. There is a base station 5 kilometers away but the lowest signal strength in the valley is less than -100dBm . A 42 meter mast used for other purposes is located on one of the hills and is available for a repeater installation as illustrated in Figure 1-12.

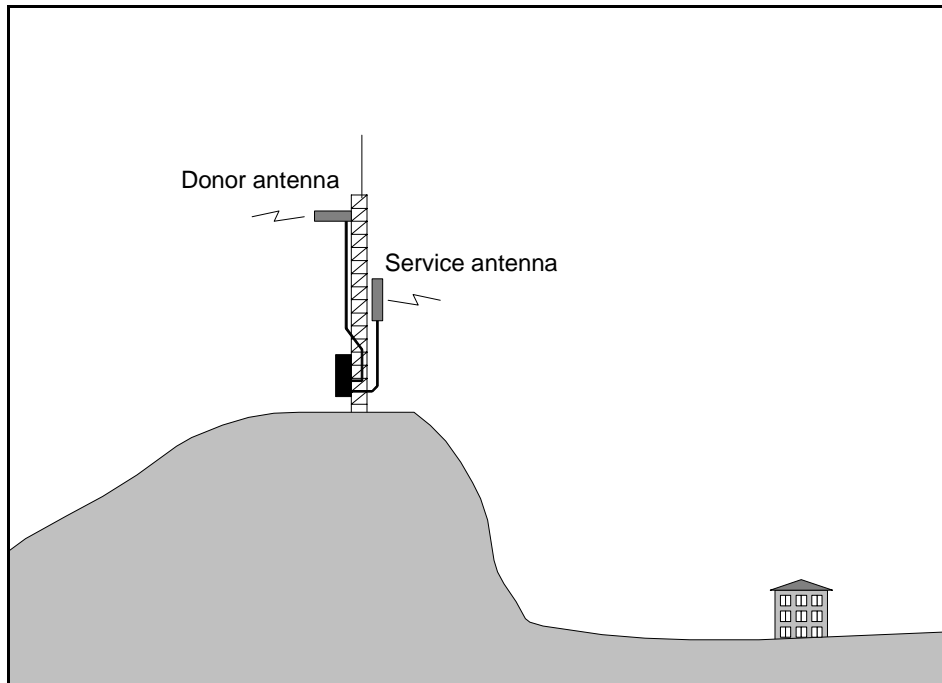

Figure 1-13 Repeater coverage of shaded area.

The donor antenna was mounted at the top of the mast and the service antenna was mounted at half mast on the other side. Antenna isolation was measured to over 100dB and the repeater was set to 80dB gain.

Measured levels:	Received signal level	-60.0 dBm
	Donor antenna gain	15.0 dBi
	Cable loss	-5.0 dB
	Repeater input level	-50.0 dBm
	Adjusted repeater gain	70.0 dB
	Repeater output level	20.0 dBm
	Cable loss	-5.0 dB
	Service antenna gain	8.0 dBi
	Radiated output level	23.0 dBm

The measured result in the valley was better than -90dBm .

Sports Arena

In this example, we have a 2000 spectator sports arena with a metallic roof that had an indoor signal strength too low to provide fair service in most parts of the arena. The nearest base station was 8 kilometers away and was equipped with only one carrier. A donor antenna directed towards the BTS was mounted on a mast outside the building and a repeater was installed inside the building with the service antenna on the ceiling as illustrated in Figure 1-14.

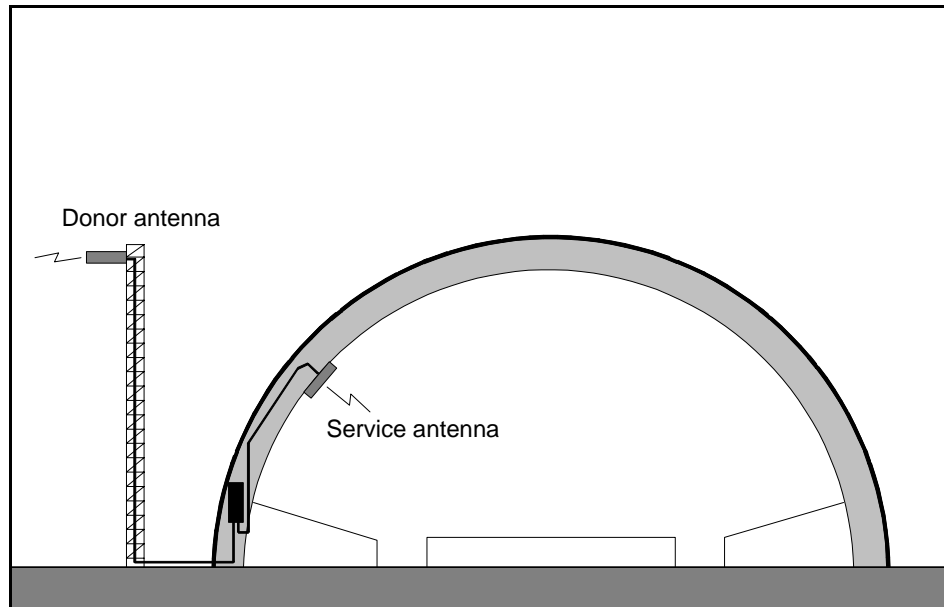

Figure 1-14 Repeater in sports arena.

The antenna isolation was measured to over 85dB.

Measured levels:	Received signal level	- 80.0 dBm
	Donor antenna gain	15.0 dBi
	Cable loss	- 5.0 dB
	Repeater input level	- 70.0 dBm
	Adjusted repeater gain	75.0 dB
	Repeater output level	5.0 dBm
	Cable loss	- 2.0 dB
	Service antenna gain	7.0 dBi
	Radiated output level	10.0 dBm

The signal strength was fair for service in the entire arena.

Fiber Optic Distribution Networks

Fiber optic networks are setup identically to data networks by using either a star or daisy-chain configuration. The two examples below illustrate part of a road covered by a BMU or RMU and four FORs. Figure 1-15 illustrates a star configuration where a BMU is fed by a BTS via an RF cable and four fiber optic ports that feed four FORs. The BMU has to be located very close to the BTS.

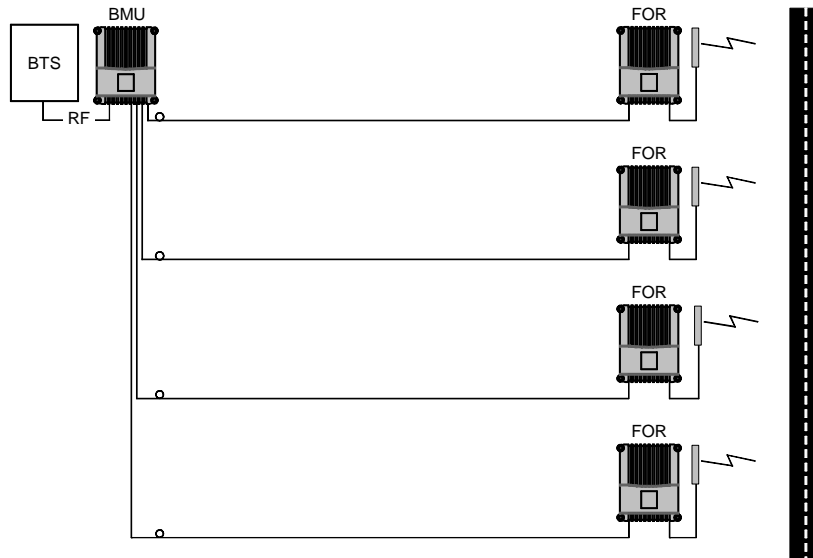

Figure 1-15 Star Configuration Using One BMU and Four FORs

Figure 1-16 illustrates a daisy-chain configuration where a RMU with a donor antenna and one fiber optic port feeds four FORs.

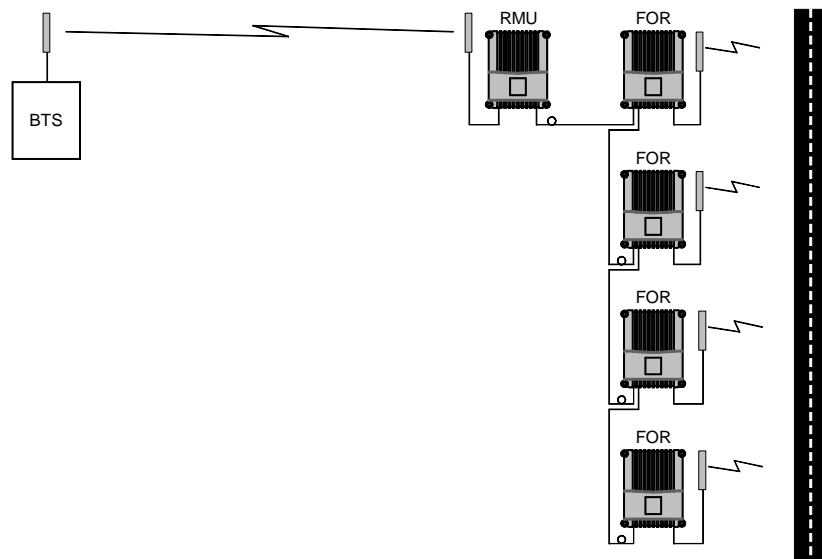

Figure 1-16 Daisy-chain Configuration Using One RMU and Four FORs

By using WDMs and OSPs in the FORs, the distribution net can be built up with a combination of star and daisy-chain connections using double or single fiber.

Multi-Operator Configurations

Multi-operator systems require the use of Point of Interconnects (POIs), RF Combining Modules (RCMs) and OCMs as illustrated in Figure 1-17. In this simple example, two operators have two sectors each. Each sector is connected to a POI and then to a RCM. The RCM is interconnected with an OCM via coaxial cables. The combined DL and UL signals are converted to optical signals in the OCM and then distributed to the ARs.

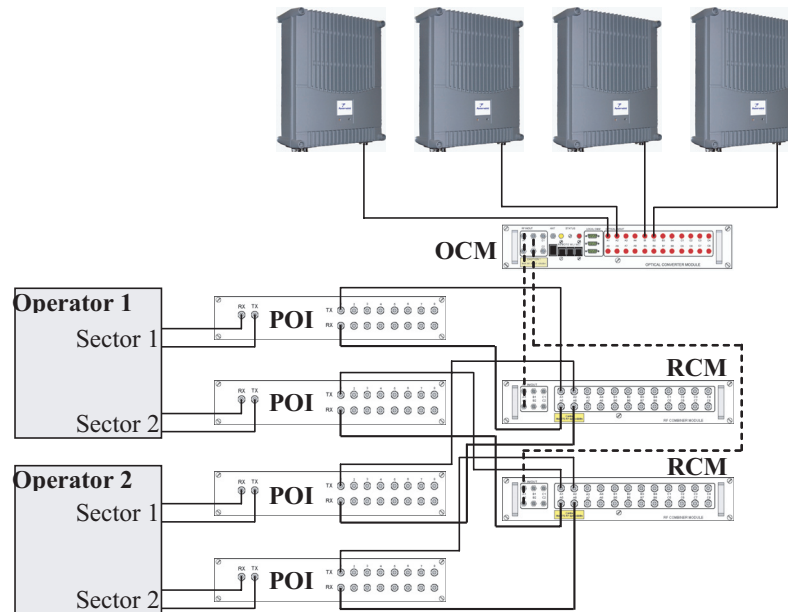

Figure 1-17 Multi-operator System

The example illustrates a star networking connection. The ARs could also be connected in a daisy-chain configuration using splitters. The complete system is properly tuned during commissioning. Additional information is provided in the Fiber Optic Equipment Operation and Maintenance Manual.

This Page Intentionally Left Blank

Chapter 2

Controls, Connections and Indicators

Introduction

This chapter contains descriptions of the controls, connections and indicators of the AR Standard Repeater.

Front Cover LED Indicators

Two LEDs are located on the front cover to provide easy identification of a fault in the repeater system. The amber operation LED lights up approximately 15 seconds after the main power is switched on. When the LED is steady, the repeater is ready for operation. The red Alarm LED indicates system error alarms when flashing and a critical alarm when steady.

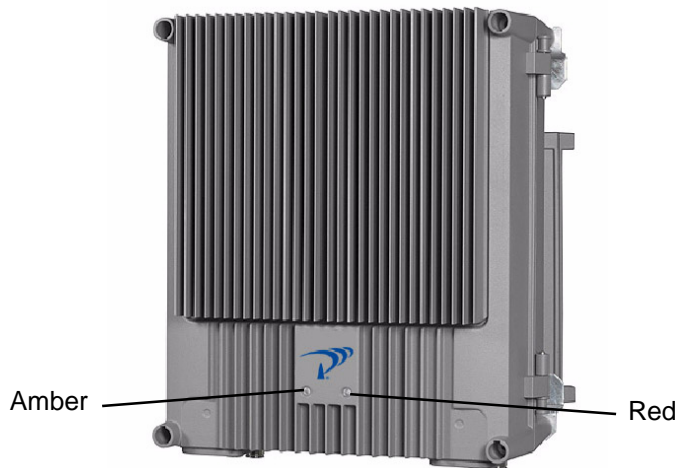

Figure 2-1 External indicators

Cabinet LED Indicators

Figure 2-2 illustrates and Table 2-1 describes the LED indicators located on the ALI, or RCI, and CU PCBAs. This is not applicable to the BMU which uses the LED indicators located on the FON. These indicators are described in further detail in the following sections.

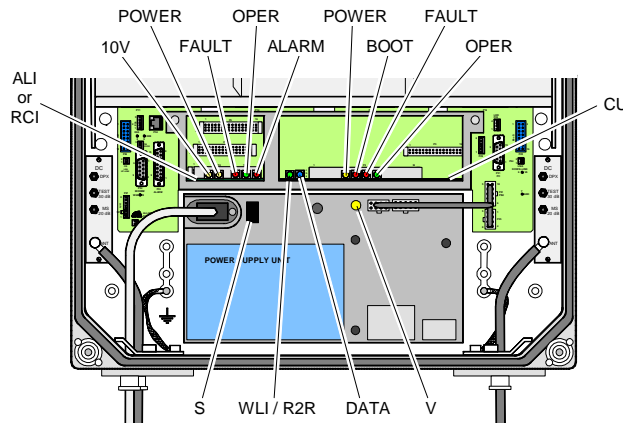

Figure 2-2 Cabinet Internal Indicators

Table 2-1 LED Indicators

LED	Description
ALI or RCI PCBA	
10V	Green LED, indicates 10V power is available and within specification
POWER	Yellow LED, indicates power is present and remains steady after power is switched on.
FAULT	Red LED, flashes for 15 – 20 seconds after main power is switched on. Flashes for less serious alarms (Error) and is ON steady for fatal alarms (Critical).
OPER	Green LED, ON steady indicates repeater is ready for operation.
ALARM	Red LED, indicates a failure within the repeater.
CU PCBA	
WLI/R2R	WLI wire network (IP). A flashing green LED indicates the unit is receiving data over the subcarrier. A steady green LED indicates: the unit is currently not receiving any data, is currently not a control station or there is no other node in the network.
DATA	Blue LED indicating data transmission in the W-net.
POWER	Yellow LED indicating present power and remains steady after power is switched on.
BOOT	Steady red LED when the CU boots (10 – 15 seconds after main power is switched on), then flashing red (5 – 10 seconds), then off if no error is detected. If an error is detected LED will stay on.
FAULT	Flashing red LED for 15 – 20 seconds after main power is switched on. Flashes for less serious alarms (Error) and is on solid for fatal alarms (Critical).
OPER	Steady green LED indicates repeater is ready for operation.

PCBA Connections

The following paragraphs describe the connectors on the main PCBAs inside the AR repeater.

CHE PCBA

Table 2-2 lists the connectors and connections for the CHE PCBA. Coaxial connector P101 is the input port and coaxial connector P701 is the output port. The output signal from this port is fed to the duplex filter either directly or via a combiner depending on the repeater configuration.

Table 2-2 CHE PCBA Connections

Port	Connected to
CHE1/DL (position 1 from left)	
P101	OUT2 on the LNA/DL low noise amplifier
P701	4 channels: Input on the CMB/DL combiner 2 channels: HI on the service DPX duplex filter
CHE2/DL (position 2 from left)	
P101	OUT1 on the LNA/DL low noise amplifier

P701	Input on the CMB/DL combiner
CHE3/UL (position 3 from left)	
P101	OUT1 on the LNA/UL low noise amplifier
P701	4 channels: Input on the CMB/UL combiner 2 channels: LO on the service DPX duplex filter
CHE4/UL (position 4 from left)	
P101	OUT2 on the LNA/UL low noise amplifier
P701	Input on the CMB/UL combiner



WARNING: The CHE PCBA has power transistors which may contain beryllium oxide (BeO) that is poisonous. Refer to the Safety section located in Chapter 1.

CSA PCBA

Table 2-3 lists the connectors and connections for the CSA PCABA. Coaxial connector P101 is the input port and coaxial connector P301 is the output port. The signal from this port is fed to the PA input port P4. The PA output port P5 is connected to the duplex filter of the same path direction.

Table 2-3 CSA PCBA Connections

Port	Connected to
CSA/DL (position 1 from left)	
P101	OUT1 on the LNA/DL low noise amplifier
P301	P4 on the PA/DL PCBA
PA/DL (position 2 from left)	
P4	P301 on the CSA/DL PCBA
P5	For the channel selective high power CDMA/WCDMA repeater: P3 on the BA/DL PCBA For all other models: HI on the service DPX duplex filter
CSA/UL (position 3 from left)	
P101	OUT1 on the LNA/UL low noise amplifier
P301	P4 on the PA/UL PCBA
PA/UL (position 4 from left)	
P4	P301 on the CSA/UL PCBA
P5	LO on the donor DPX duplex filter

BSA PCBA

Table 2-4 lists the connectors and connections for the BSA PCABA. Coaxial connector P101 is the input port and coaxial connector P301 is the output port. The signal from this port is fed to the PA input port P4. The PA output port P5 is connected to the duplex filter of the same path direction.

Table 2-4 BSA PCBA Connections

Port	Connected to
BSA/DL (position 1 from left)	
P101	OUT1 on the LNA/DL low noise amplifier
P301	P4 on the PA/DL PCBA
PA/DL (position 2 from left)	
P4	P301 on the BSA/DL PCBA
P5	HI on the service DPX duplex filter
BSA/UL (position 3 from left)	
P101	OUT1 on the LNA/UL low noise amplifier
P301	P4 on the PA/UL PCBA
PA/UL (position 4 from left)	
P4	P301 on the BSA/UL PCBA
P5	LO on the donor DPX duplex filter

PA PCBA

Coaxial connector P4 is the input port and coaxial connector P5 is the output port. PA output port P5 is connected to the DPX of the same path direction.



WARNING: The PA PCBA has power transistors which may contain beryllium oxide (BeO) that is poisonous. Refer to the Safety section located in Chapter 1.

BA PCBA

Table 2-5 lists the connectors and connections for the BA PCABA. Coaxial connector P3 is the input port (fed by the DL PA) and coaxial connector P4 is the output port. The signal from this output is fed, via the DL DPX and DC, to the DL antenna.

Table 2-5 BA PCBA Connections

Port	Connected to
P3	P5 on the PA/DL PCBA
P4	HI on the service DPX

DIA – Distribution PCBA

The DIA is exclusively equipped with connectors and provides signal distribution for most of the PCBAs, units and ports in the repeater. Pins 2 and 3 on connector P27 must be interconnected with a jumper if the connector is not used. Figure 2-3 illustrates the DIA and Table 2-6 lists the connectors and connections.

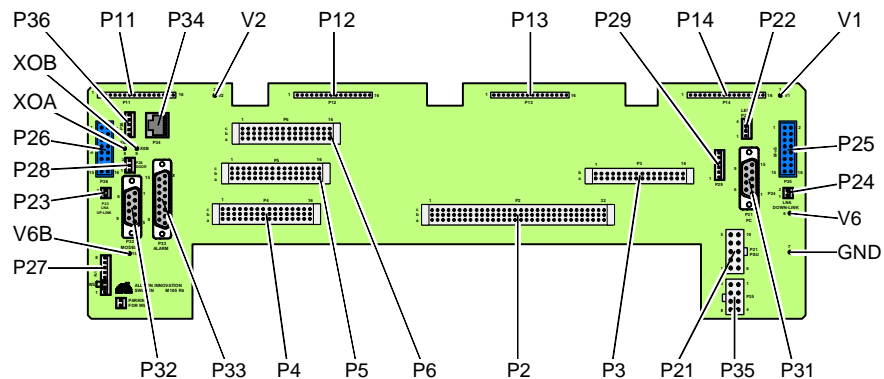

Figure 2-3 DIA PCBA connectors and testpoints

Table 2-6 DIA PCBA Connections

Port	Connected to
P2	CU PCBA
P3, 5, 6	Not Used
P4	ALI or RCI PCBA
P11 - 14	Channel PCBA positions 1 through 4
P21	PSU, connector 1
P22	LED PCBA in cover
P23	LNA/UL
P24	LNA/DL
P25	Expansion output port to cover circuitry. Only in cabinets.
P26	Expansion input port to cover circuitry. Used in equipped high covers.
P27	AUX1
P28	Door switch
P29	Power to FON
P31	PC RS-232
P32	Modem RS-232
P33	External Alarm
P34	WLI for IP or R2R network
P35	PSU, connector 2
P36	WLI for IP or R2R network

DC

The DCs are located on the left and right side in the lower part of the cabinet if a test port (TEST -30 dB) or an antenna port (MS -20 dB) for an internal RF modem is required. Figure 2-4 illustrates the DC and Table 2-7 lists the connectors and connections.

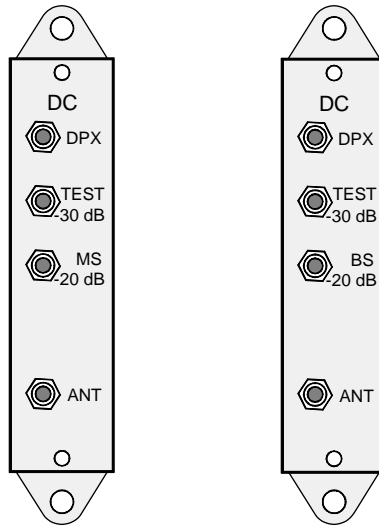

Figure 2-4 Directional Couplers

Table 2-7 Directional Coupler Connections

Service DC Port	Connected to
DPX	ANT on the service DPX filter
TEST -30dB	Test port for the downlink output signal (no directivity)
MS -20dB	Not used
ANT	Service antenna or RF service cable
Donor DC Port	Connected to
DPX	BMU: BTS antenna All other types: ANT on the donor DPX duplex filter
TEST -30dB	Test port for the uplink output signal (no directivity)
BS -20dB	BMU: ANT on the FOU/DPX filter All other types: Antenna connection for remote control RF modem. This port has at least 20dB directivity towards the antenna.
ANT	BMU: BTS antenna output port. All other types: Donor antenna (or RF cable to BTS).

LNA

Figure 2-5 illustrates the LNA and Table 2-8 lists the connectors and connections. All coaxial connectors are SMA-type. Signals from the DPX output are fed to the LNA input connector IN. OUT1 and OUT2 outputs feed the CHE, CSA or BSA of the same signal direction.

The signal level in these connectors are +20dB referenced to the antenna input. OUT LOW is an expansion output for an additional LNA if the repeater is equipped in a high cover. The gain to this connector is +2dB. The +7V input is used for +7V supply from the DIA PCBA and ATT is a control signal for a controllable attenuator in the LNA.

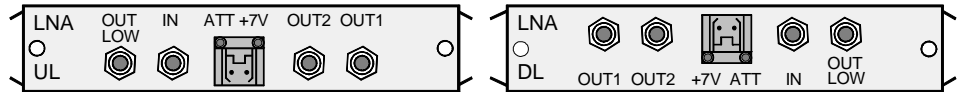

Figure 2-5 Low Noise Amplifiers

Table 2-8 Low Noise Amplifier Connections

LNA/UL Port	Connected to
OUT LOW	IN on the LNA/UL in the cover, if equipped
IN	LO on the service DPX duplex filter.
ATT +7V	P23 on the DIA PCBA.
OUT1	P101 on the CHE3/UL, CSA/UL, or BSA/UL PCBA. P2101 on the WBA PCBA.
OUT2	P101 on the CHE4/UL channel PCBA.
LNA/DL Port	Connected to
OUT LOW	IN on the LNA/DL in the cover, if equipped
IN	HI on the donor DPX duplex filter.
ATT +7V	P24 on the DIA PCBA.
OUT1	P101 on the CHE2/DL, CSA/DL, or BSA/DL PCBA. P2102 on the WBA PCBA.
OUT2	P101 on the CHE1/DL channel PCBA.

Not used outputs do not need to be terminated.



WARNING: Some LNA power transistors may contain beryllium oxide (BeO) that is poisonous. Refer to the Safety section in Chapter 1

DPX

DPXs are located on the metal cover sheet in the upper part of the cabinet. Service and donor filters are identical. A DPX filter is also included in the FOU. This filter can be connected to various ports depending on the repeater type. Table 2-9 lists the connectors and connections of the DPX.

Table 2-9 DPX Connections

Service DPX Port	Connected to
ANT	<i>RMU</i> : ANT on the FOU/DPX filter <i>All other types</i> : Service antenna (or DPX on the service (MS) DC
HI	CSeI GSM repeater: 4 channels: Output on the CMB/DL 2 channels: P701 on the CHE1/DL CSeI CDMA/WCDMA and BSeI repeaters: P5 on the PA/DL High power CDMA/WCDMA repeater: P4 on the BA/DL PCBA in the cover
LO	IN on the LNA/UL P2101 on the WBA PCBA
Donor DPX Port	Connected to
ANT	<i>FOR</i> : ANT on the FOU/DPX filter. <i>All other types</i> : DPX on the donor (BS) DC
HI	IN on the LNA/DL
LO	CSeI GSM repeater: 4 channels: Output on the CMB/UL 2 channels: P701 on the CHE3/UL CSeI CDMA/WCDMA, High power CDMA/WCDMA and BSeI repeaters: P5 on the PA/UL

FOU

FOU connections depend on the repeater type and if the FOU is connected to the donor or service side. The RF connections for the FOU and the DPX used on the RF side are illustrated in Figure 2-6 and listed in Table 2-10.

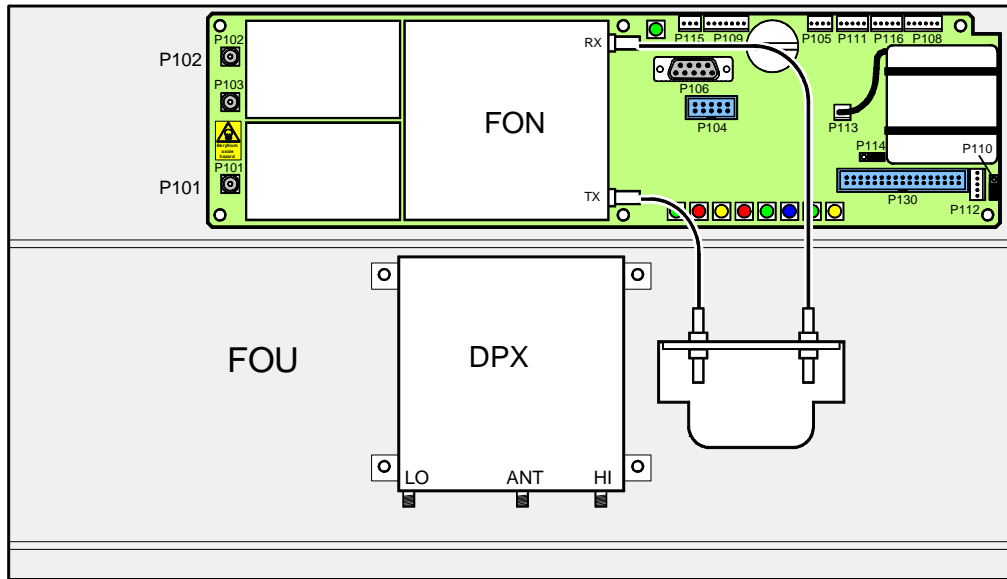

Figure 2-6 FOU

Table 2-10 FOU/DPX connections

on the donor side (BMU or RMU)	
Port	Connected to
ANT	<i>BMU</i> : BS -20dB on the donor (BS) DC <i>RMU</i> : DPX on the donor (BS) DC
HI	<i>BMU</i> : P101 on the FON (or a CMB or CMD) <i>RMU</i> : IN on the LNA/DL
LO	<i>BMU</i> : P102 on the FON (or a CMB or CMD) <i>RMU</i> : P5 on the PA/UL
on the service side (FOR and WRH)	
Port	Connected to
ANT	Service antenna
HI	<i>FOR</i> : P5 on the PA/DL <i>WRH</i> : P5 on the PA/DL or P4 on the BA
LO	<i>FOR</i> : IN on the LNA/UL <i>WRH</i> : IN on the LNA/UL or P2 101 on the WBA

FON

The FON is illustrated in Figure 2-7 and the LED indicators are described in Table 2-11. The FON has three coaxial ports and two optical ports for the downlink and uplink RF signal. Table 2-12 defines the port numbers, connector types, and port usage.



WARNING: There are two attenuators at the P101 port on the FON that may contain Beryllium oxide (BeO), which is poisonous. The attenuators are found inside the shield.

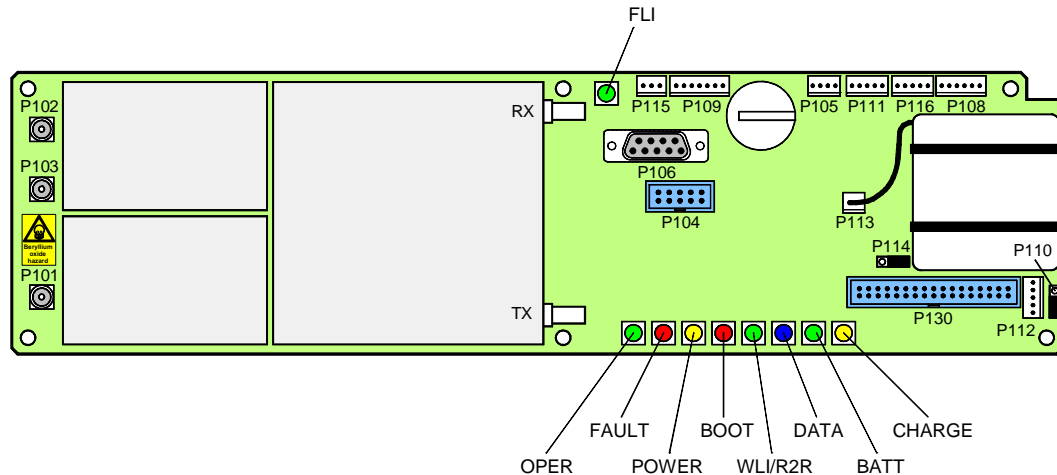

Figure 2-7 FON LED Indicators

Table 2-11 FON LED Indications

LED	Description
FLI or F2F	Green LED. When flashing, indicates the unit is receiving data over the sub carrier. A steady LED indicates a sub carrier is detected but the unit is not receiving any data or there is no other node in the network.
OPER	Green LED. Lights up for approximately 15 seconds after the mains is switched on. When ON steady, indicates the unit is ready for operation.
FAULT	Red LED. Flashes for 15 – 20 seconds after the mains is switched on. Will flash for less serious alarms and be steady for fatal alarms.
POWER	Yellow LED. Indicates power is present
BOOT	Red LED. Will be ON steady when the control unit boots up (10 – 15 seconds after the mains is switched on). Enters a flashing state next for 5 – 10 seconds. If no error is detected, the LED is off. If an error occurs, the LED remains on.
WLI	Green LED. When flashing indicates unit is receiving data over the sub-carrier. A steady LED indicates one of the following: The unit is not currently receiving any data, the unit is not currently a control station or there is no other node in the network.
DATA	Blue LED. Indicates data transmission in the W-net
BATT	Green LED. ON steady indicates battery pack is currently used as power source.
CHARGE	Yellow LED. ON steady indicates battery charging

Table 2-12 FON Connectors

Port	Type	Description
P101	SMA	Electrical RF input port (to the optical TX port)
P102	SMA	Electrical RF output port (from the optical RX port)
P103	SMA	Electrical RF output port (15dB below the P102 port)
RX	DIN/APC	Optical input port (to the P102 and P103 RF ports)
TX	DIN/APC	Optical output port (from the P101 RF port)
P104		Used only for development and debugging
P105	4 pin male	Door LED indicators. Used for the yellow and red LED indicators located on the front cabinet door
P106	9 pin D-sub female	RS-232 used for local PC communication
P108 P116	6 pin male	Parallel connected power ports for the FON
P109	7 pin male	Used for external alarm sensors
P110	W-link jumper	Used to terminate units in a W-link. It has to be set in the parking state for all units except for the first and last units in a W-link. The Parking state (P) has the jumper between the center and bottom pins. The opposite state (T) terminates the W-link.
P111 P112	5 pin male	WLI ports used for interconnecting nodes in WLI-nets (IP or R2R networks). They are identical and connected in parallel. One of the connectors are intended to be used from the previous node and the other connector to the next node in the network. Either can be used for the first and last unit in the net chain.
P113	2 pin male	Batteries - used for the on-PCBA backup batteries.
P114	Backup power output jumper	Sets the backup power output state. The OFF state has jumper between the center and left pins. This jumper has to be in the OFF state when used in an OCM. Otherwise, it shall be in the ON state.
P115	3 pin male	Future port - intended for future use
P130	34 pin, 2 line male	RCU port used for connecting an RCU. The connector contains both the modem connection and RCU power supply.

PSU

The PSU is located in the bottom middle of the cabinet or in an equipped high cover as illustrated in Figure 2-8. The PSU has all the voltages required for all repeater types. It has capacity for one repeater, including the radio circuitry, fiber optics, modem, etc. In some high power repeater types, the PSU also supplies the BA. Multi-band high power repeaters always require a second PSU. There are two PSU types with different input voltages:

1. 115/230V 50/60Hz, 300W input max.
2. 21- 60V DC, 300W input max.

The DIA provides most of the internal connection between the repeater units and to external ports. Connectors involved in the installation are also located on the DIA. Table 2-13 describes these connections.

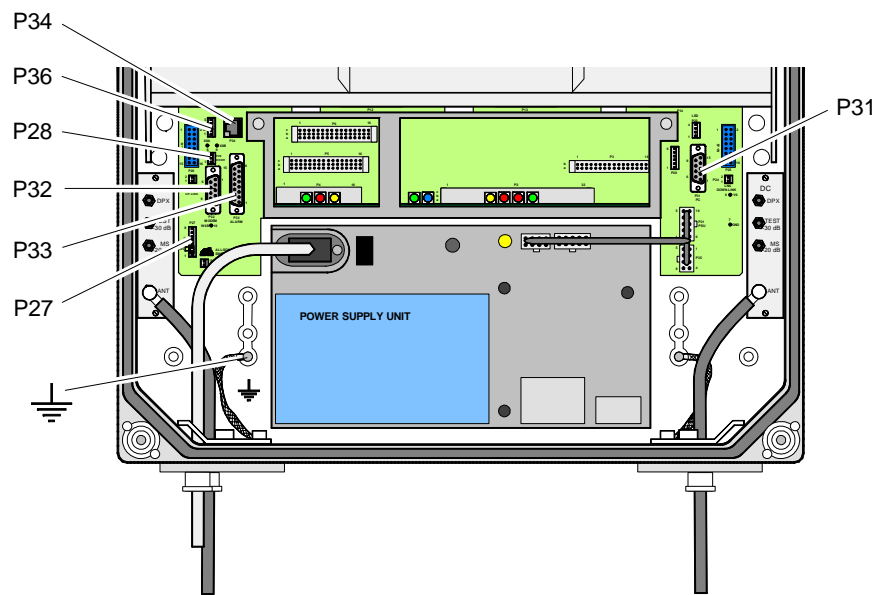

Figure 2-8 Power Supply Unit (PSU)

Table 2-13 PSU Connectors

Port	Description
P27	Auxiliary Port (8-pin male) - Used to power the old RCU. It is located on the DIA to the left in the cabinet. Pins 2 and 3 must always be interconnected to provide the CU and ALI/RCI PCBs with voltage supply. If there is no cable connected, pins 2 and 3 must be interconnected with a jumper.
P31	RS-232 PC Port (9-pin D-sub female) - Used for local PC communication. It is located on the DIA to the right in the cabinet.
P32	RS-232 Modem port (9-pin D-sub male) - V.24 interface used for the old RCU. It is located on the DIA to the left in the cabinet.

P33	<p>Alarm Port (15-pin D-sub female) - Used for external alarm sensors and alarm equipment. It is located on the DIA to the left in the cabinet. The port has four alarm inputs, EAL1 – EAL4, and two alarm outputs.</p> <p>The four alarm inputs are low-level inputs with common ground (AIC). Use insulated switch or relay to initiate alarms (open switches in normal operating mode, closed switches cause alarm). The alarm switch connection can be toggled between active open and active closed. This is further described in the OM-Online User Manual and the Advanced Repeater OMS User Manual.</p> <p>The alarm input voltage ratings, related to ground (AIC), are: Vinmax= 5.5V, Vinmin= –0.5V</p> <p>The four alarm inputs are connected to the following pins: Pin 14 AI1 External alarm input 1 - EAL1 Pin 15 AI2 External alarm input 2 - EAL2 Pin 7 AI3 External alarm input 3 - EAL3 Pin 8 AI4 External alarm input 4 - EAL4 Pin 6 AIC Ground. See also the P28 door switch port below.</p> <p>Two alarm outputs are 1 pole closing and 1 pole opening relay outputs insulated from each other. Maximum ratings, related to ground or any other alarm terminal, are 50V AC / 60V DC. The alarm outputs are defined as follows: Pin 9 and 1 AO1 and AO8 Closed when operating, otherwise open. Pin 10 and 2 AO6 and AO7 Open when operating, otherwise closed. Pin 11 and 3 AO2 and AO5 Closed at alarm state, otherwise open. Pin 12 and 4 AO3 and AO4 Open at alarm state, otherwise closed.</p>
P28	<p>Door switch port - Normally, alarm input AI4 is used for repeater door opening alarm EAL4 which is arranged using an optional door switch. Signal AI4 and AIC are thus available also in the P28 connector, to which the door switch is connected. It is located on the DIA to the left in the cabinet. The EAL4 door switch alarm is activated 10 – 30 seconds after the cover has been opened.</p>
P34	<p>WLI Port (8-pin RJ45 female) - Used for the WLI network (R2R). It is located on the DIA to the left in the cabinet.</p>
P36	<p>WLI Port (5-pin male) - Used for the WLI network (IP or R2R). It is located on the DIA to the left in the cabinet. Connecting P111 or P112 on a FON to this port, an FLI network is interconnected to a WLI network (IP or R2R) making all the included repeaters in both the networks accessible.</p>

Software and Hardware Compatibility

There are different versions of repeater CU software which can be combined with PCBAs of various revisions. These have unique part numbers and revision information. Below, you will find a table of repeater software currently available in combination with CU PCBA revisions.

Table 2-14 Hardware / Software Compatibility

CU PCBA part #	CU Software part #	Comments
K103/1 or K103/2	SA102 01/2	For GSM channel selective = 4 channels, band selective 800-900MHz fixed bandwidth only, and combined repeater (800/900MHz). No traffic statistics.
K103/2	SA102 02/1	For GSM, DCS, PCS channel selective = 8 channels, band selective 800 – 900MHz fixed or adjustable bandwidth, band selective 1800MHz or 1900MHz and combined repeater. Supports R2R link. Supports stacked channels.
K103/2	SA102 02/2	For 800/1900MHz CDMA = 4 channels.
	SA102 02/4	For 800/1900MHz channel selective operation.
	SA102 02/5	For 800/1900MHz band selective operation.
K103/3	SA102 06/x SA102 07/x SA102 08/x	More memory. MAC ID is added on the PCBA. R2R functionality integrated.

This information is accurate as of 1/31/2007. As new versions of hardware and software are released without prior noticing, contact your Powerwave sales representative if in doubt about the latest revision status.

For detailed information, refer to the release notes for the CU software to be downloaded (normally found in the readme.txt file provided with the program files).

Chapter 3

Installation

Introduction

This chapter contains unpacking, inspection and installation instructions for installing and powering up the AR Standard Repeater.

Site Survey

Powerwave recommends that a site survey be performed prior to equipment ordering or installation. Performing a detailed site survey reduces or eliminates installation and turn-up delays. Pay particular attention to power plant capacity, cooling needs, floor space, and RF/DC cabling/breaker requirements. Cabinet dimensions, clearance dimensions, and weights are listed in Chapter 5.

Unpacking and Inspection

This equipment has been operated, tested, and calibrated at the factory. Carefully open containers to remove equipment. Retain all packing material that can be reassembled in the event unit must be returned to the factory. Perform the following steps:

- Visually inspect equipment for damage that may have occurred during shipment. If possible, in the presence of the delivery person.
- Check for evidence of water damage, bent or warped chassis, loose screws or nuts, or extraneous packing material in connectors.

If equipment is damaged, file a claim with the carrier once the extent of any damage is assessed.

If equipment must be returned to factory, please contact factory for a Return Material Authorization (RMA). See Chapter 4.

Repeater Location

Powerwave repeaters are designed with a weather proof outdoor cabinet that can be mounted without any kind of shelter from rain, snow or hail. The same unit can be installed indoors. A preferable site for the repeater is a location free of obstructions, easily accessible and allows for proper air-flow and ventilation.

If a repeater is installed outdoor and can be exposed to direct sunshine, it is essential that air can circulate around the repeater with no obstacle. The operating temperature must not exceed 131°F (55°C). A shelter can be used to shade the repeater from direct sunshine.

Never open a repeater when rain, snow, hail, high humidity or high winds are present unless some kind of temporary shelter can be erected. Limitations for very bad weather are found in the next section.

Mounting

The AR repeater is easy to mount using the provided mounting bracket, illustrated in Figure 3-1, which has 9/16" (14mm) holes for 3/8" (10mm) or 1/2" (12mm) fixing screws. Clamps with C-C measures of 3.5" (90mm), 5.3" (135mm), 5.7" (144mm), 8.1" (205mm), 9.8" (250mm), and 11.8" (300mm) can be used as well. The vertical C-C measure for these are 16.2" (411mm). There is a 9/16" (14mm) single hole in the middle of the mounting bracket, marked 'A' in the figure, which is intended for a locking screw to lock the bracket into place.

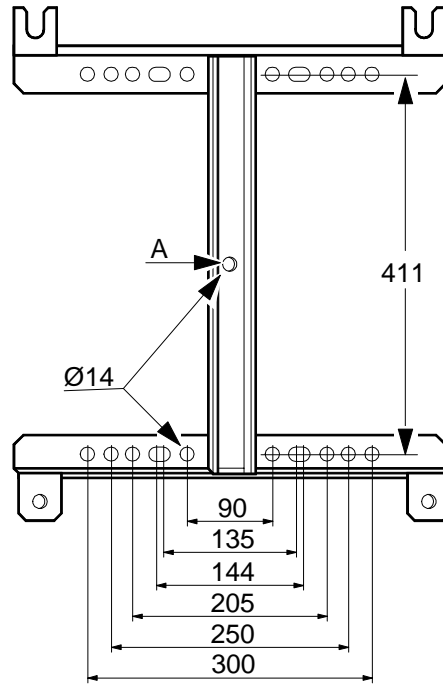

Figure 3-1 Mounting bracket

Normally, the AR repeater is mounted on a wall, pole or mast. Figure 3-2 illustrates the installation of the mounting bracket on a wall using four fixing screws and a locking screw.

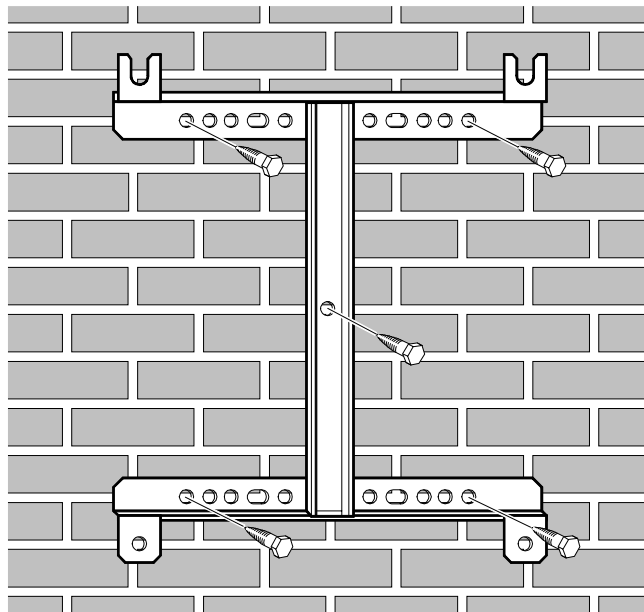

Figure 3-2 Mounting bracket installation on wall

Figure 3-3 illustrates the installation of the mounting bracket on a pole using two 5.7" (144mm) U-shaped clamps and a locking screw.

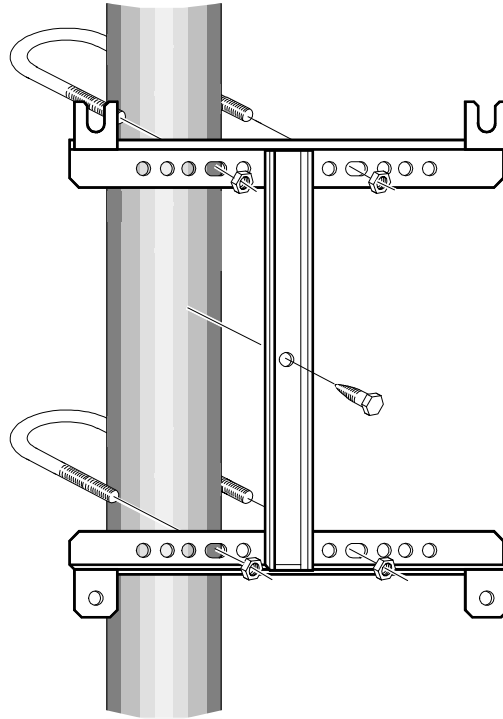

Figure 3-3 Attaching the bracket to a pole

Figure 3-4 illustrates a mast installation using two 11.8" (300mm) bar-shaped clamps and no locking screw.

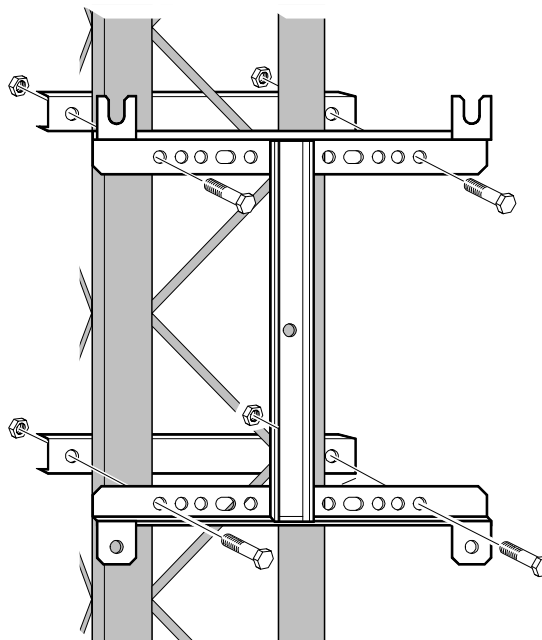

Figure 3-4 Attaching the bracket to a mast

After installing the mounting bracket, hang the repeater on the upper supports, as illustrated in Figure 3-5. Tighten the upper and lower mounting screws to secure it into place. Locking cylinders, used to prevent unauthorized removal of the repeater, can be inserted and locked with a key after the lower screws have been tightened. Make sure the donor antenna, directed towards the BTS antenna, and the service antenna, directed towards the area to be covered by the repeater, are mounted and installed properly.

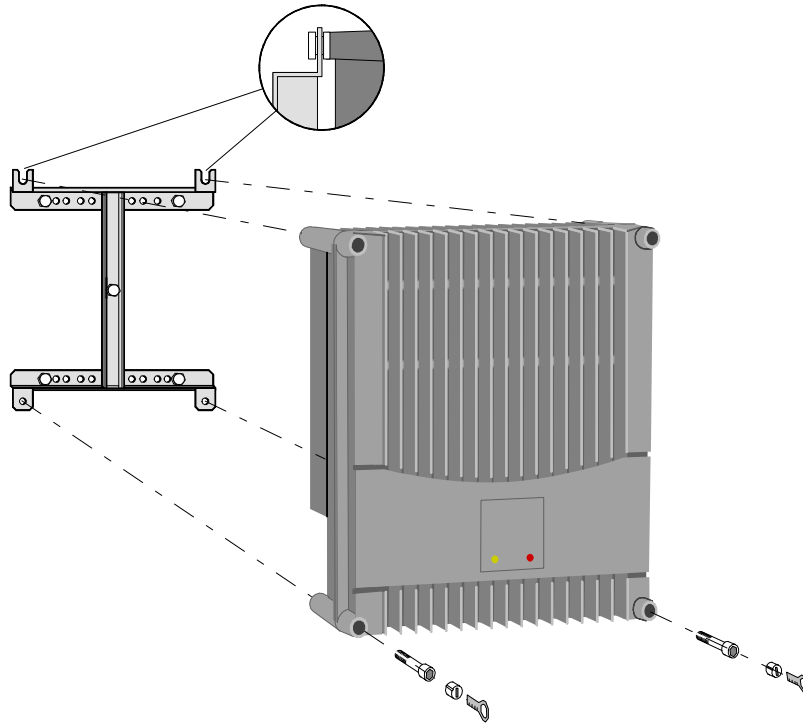

Figure 3-5 Attaching the repeater to the bracket

Connections

This section describes general examples of how to connect the input and output ports on the following repeater types:

- RF to RF repeaters
- BMU (RF to fiber optics)
- RMU (RF to fiber optics)
- FOR (fiber optics to RF)

Main Power and Grounding

Local regulations need to be followed for the main power connection. AR repeaters are approved in accordance with EN and UL/cUL regulations. This is, however, only valid if a classified power cord is used. For the repeater to meet these regulations you must select one of the following classified and approved cord types:

- EN – H 05 W5 - F HMR
- UL – AWM Style 2587
- CSA– AWM 1 A/B 11 A/B

For outdoor use, the power cord should meet at least IP65 encapsulation requirements. Do not turn the main power on until you are ready to commission the repeater



WARNING: For repeaters supplied from the main power source, the main outlet must be grounded.

RF-to-RF Repeater Connections

Figure 3-6 illustrates the cable connections applicable for standard and high power repeaters and Table 3-1 describes the steps for making the connections. The donor antenna or RF cable from the BTS is connected to the right and the service antenna is connected to the left in the cabinet.

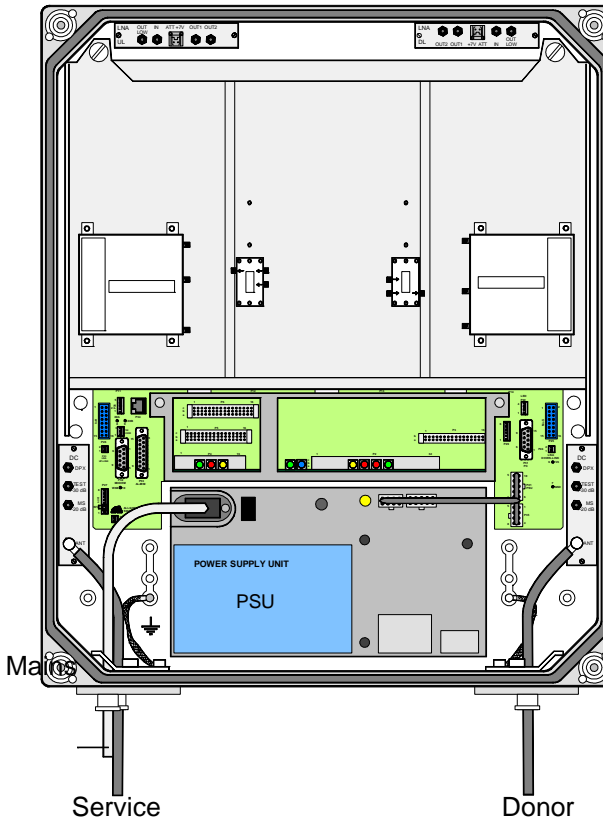

Figure 3-6 RF-to-RF Repeater Connections

Table 3-1 RF-to-RF Connections Procedure

Step	Action
1	Mount AR Repeater
2	Using N-type male connectors, connect the service and donor antenna coaxial cables (or RF cable from the BTS if no donor antenna is used).
3	Verify that the connector ports are tagged as such.
4	Connect station ground, if to be used, and mount the main power plug to the main power cord but do not connect the main power.

BMU RF to Fiber Optic Connections

Figure 3-7 illustrates a BMU with separate TX/RX fiber optic cables to one FOR. By using WDMs and OSPs, up to four FORs, or eight using a high cover, can be fed in parallel by one BMU with double or single fiber optic cables. Table 3-2 describes the steps for making the connections.

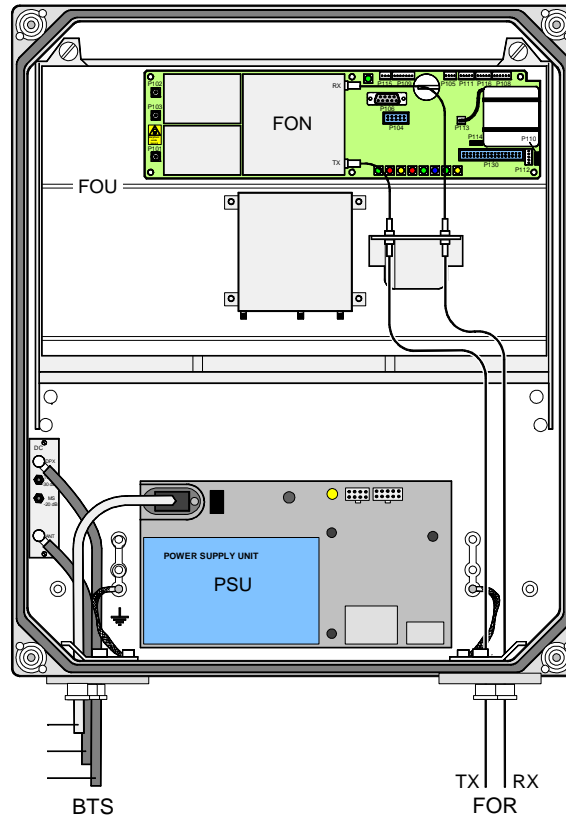

Figure 3-7 BMU RF-to-Fiber Optic Connections

Table 3-2 BMU RF-to-Fiber Connections Procedure

Step	Action
1	Mount AR Repeater
2	Using N-type male connectors, connect the BTS antenna output RF cable to the ANT port of the DC unit located on the left in the cabinet.
3	Connect an RF cable from the DPX port of the DC unit located on the left to the BTS antenna using an N-type male connector
4	Connect the TX and RX fiber optic cables from the FON located in the upper part of the FOU to a FOR.
5	Connect station ground, if to be used
6	Mount the main power plug to the main power cord but do not connect the main power.

RMU RF to Fiber Optic Connections

Figure 3-8 illustrates an RMU for donor antenna and separate TX/RX fiber optic cables to one FOR. By using WDMs and OSPs, up to four FORs, or eight using a high cover, can be fed in parallel by an RMU with double or single fiber communication. Table 3-3 describes the steps for making the connections.

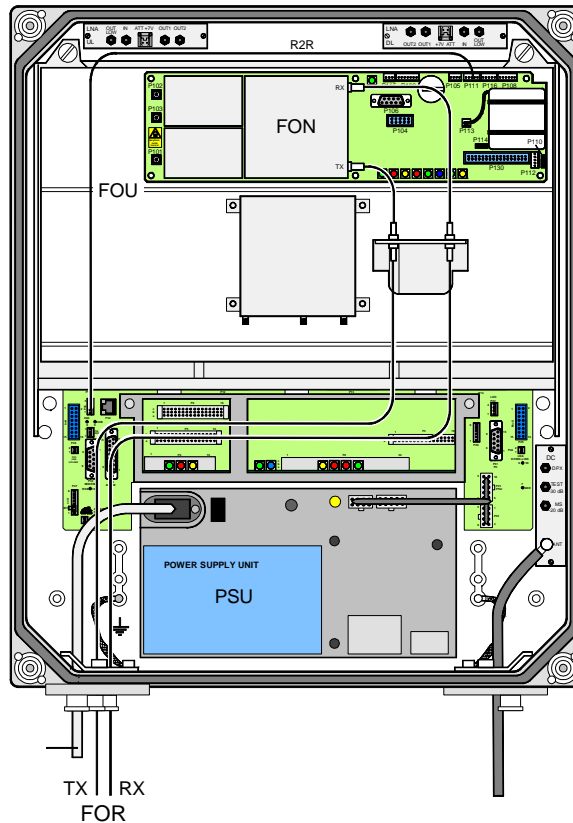

Figure 3-8 RMU RF-to-Fiber Optic Connections

Table 3-3 RMU RF-to-Fiber Connections Procedure

Step	Action
1	Mount AR Repeater
2	Connect the donor antenna coaxial cable to the right in the cabinet using an N-type male connector
3	Connect the TX and RX fiber optic cables from the FON located in the upper part of the FOU to an FOR
4	Connect station ground, if to be used
5	Mount the main power plug to the main power cord but do not connect the main power.

FOR RF to Fiber Optic Connections

Figure 3-9 illustrates a FOR for service antenna and separate TX/RX fiber optic cables from a BMU. By adding WDMs and OSPs, a number of FORs can be fed by one BMU with double or single fiber communication. Table 3-4 describes the steps for making the connections.

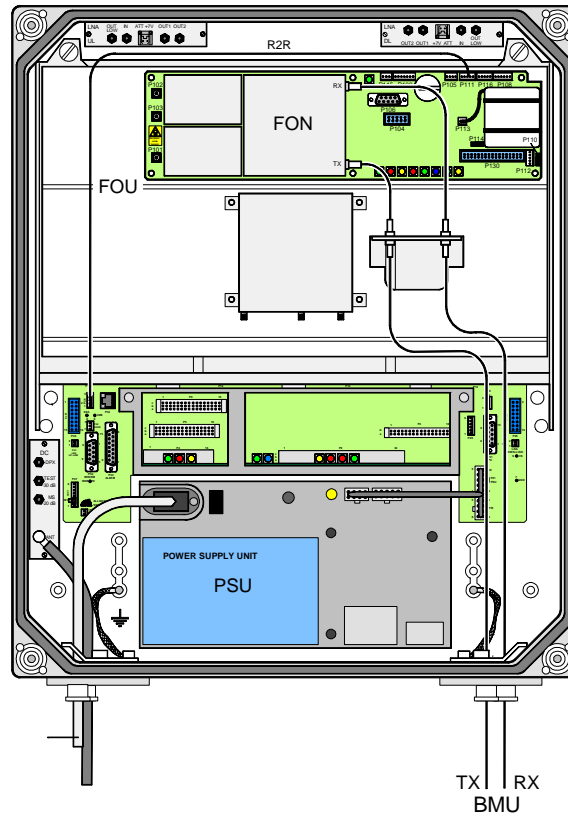

Figure 3-9 FOR RF-to-Fiber Optic Connections

Table 3-4 FOR RF-to-Fiber Connections Procedure

Step	Action
1	Mount AR Repeater
2	Connect the service antenna coaxial cable to the left in the cabinet using an N-type male connector.
3	Connect the TX and RX fiber optic cables from the BMU to the FON located in the upper part of the FOU
4	Connect station ground, if to be used
5	Mount the main power plug to the main power cord but do not connect the main power.

Optional Connections

Alarms

Alarm signals from external sensors are received by an ALI or RCI which forwards them to the CU. The RCI is used if the repeater has an RCU. The software on the CU can activate acoustic or visual alarms or direct the alarm to the P33 alarm port for forwarding via an RCU to an OM-Online or OMS workstation. Alarms can also be handled by the FON. Alarms can be configured through OM-Online or OMS.

External Alarm

Burglary, fire or other external alarms can be handled by the AR repeaters. External alarm sensors and alarm signals are connected to the P33 alarm port located to the left in the cabinet as illustrated in Figure 3-10.

The P33 alarm port is described in Chapter 2. The cable for this installation is taken through a strain relief bushing at the bottom of the repeater. For repeaters without CU and DIA PCBAs, a BMU for instance, the external alarm is connected to the P109 port on the FON. P109 is described in the FON PCBA section in Chapter 2.

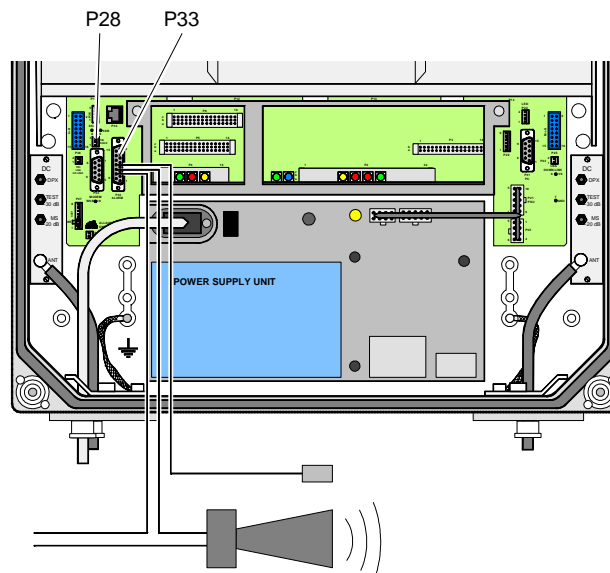

Figure 3-10 External alarm connection

Door Open Alarm

A door open alarm can be handled by all repeater types that have a CU PCBA. This is arranged with a door switch connected to port P28 illustrated in Figure 3-10. P28 and the connection is described in Chapter 2.

Fiber Link Interface (FLI)

The FLI feature makes it possible to interconnect repeaters that have a FON (BMU, RMU and FOR). By using an RF distribution fiber network, no wire or other communication device is required. Communication with repeaters in a mixed FLI and WLI network is possible.

Wire Link Interface (WLI) Network (IP to R2R)

Two types of WLI networks are available for the Powerwave repeaters: Internet Protocol (IP) and Repeater-to-Repeater Link (R2R). For R2R networks: If the repeater has a previous CU PCBA model (K103/2), then a RIA PCBA is required. Further information about the IP and R2R network is located in the *OM-Online User Manual*.

The network cables are connected to P34 or P36 WLI ports on the DIA PCBA as illustrated in Figure 3-11. The cables can either be interconnected at the P1 terminal on the connector PCBA located to the right in the cabinet or to both P34 and P36. For repeaters without CU and DIA PCBAs, the BMU for instance, the network cables are connected to port P111 and P112 on the FON.

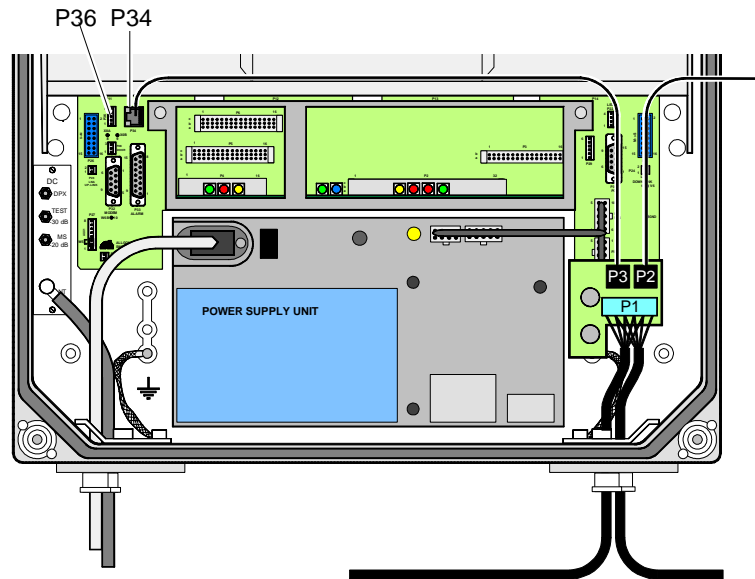

Figure 3-11 IP and R2R Network Connection

Any cable type can be used for indoor installations. For outdoor installations, the Li 2YC11Y, 2x2xAWG24/222, non-halogen, Metrofunkkabel-Union cable type is recommended. Use strain relief bushings or connectors at the bottom of the repeater. If the link cable between two repeaters is longer than 25 meters, an RS-485 repeater is required as illustrated in Figure 3-12 below.

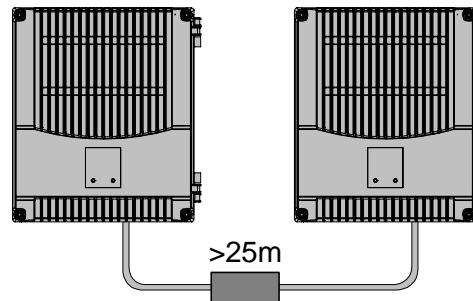

Figure 3-12 RS-485 Cable Repeater

Main Power Breakdown Relay

To be able to distinguish PSU faults from power failure, a main power breakdown relay can be used. This relay is not included in the AR repeater and has to be mounted outside the repeater cabinet. The relay intended for this purpose must fulfil the following specifications:

Closing time: Max. 30 milliseconds
 Insulation coil/contact: Min. 4KV

A main power connected relay must also be in compliance with valid local regulations. Figure 3-13 illustrates the connection points and Table 3-5 lists the steps for making the connections.

Table 3-5 Main Power Breakdown Relay Connection

Step	Action
1	Connect a currentless closed relay contact to pin A11 and A1C on the P33 alarm connector. An alarm is initiated by short-circuiting the pins. For the BMU the main power breakdown cables are connected to pin A11 and A1C in the P109 port on the FON.
2	Connect the relay coil. It must be supplied from the same fuse as the repeater.
3	After commissioning, select Mains Breakdown in the alarm configuration window in OM-Online or OMS. Refer to the OM-Online User Manual.

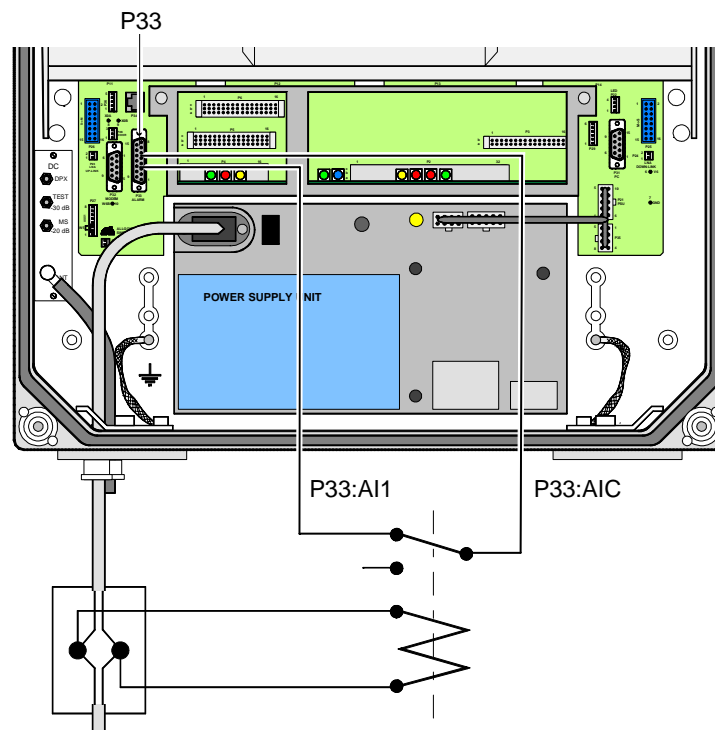

Figure 3-13 Main Power Breakdown Relay Connection

21-60 Volt DC PSU Installation

The 115/220 VAC PSU can be replaced with a 21 to 60 VDC DC PSU Figure 3-14 illustrates the location of the mounting screws and power connectors of the PSU and Table 3-6 lists the replacement procedure.

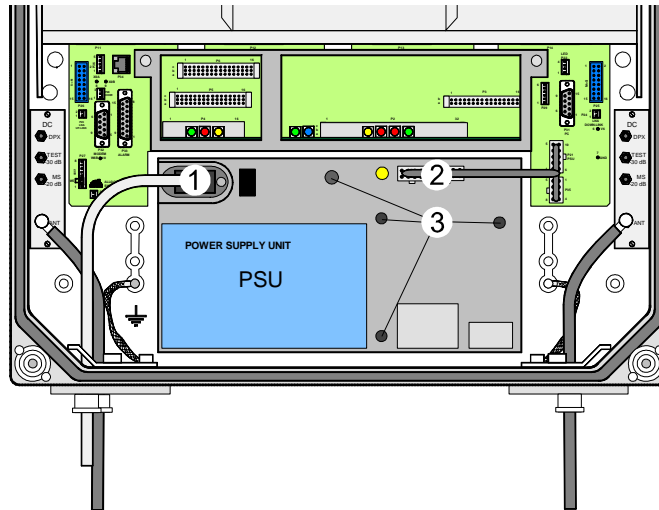

Figure 3-14 PSU Connections

Table 3-6 PSU Replacement Procedure

Step	Action
1	Disconnect main power.
2	Remove the main power plug from the PSU ('1' in Figure 3-11).
3	Disconnect the power cable bundle connectors (2) on the PSU.
4	Loosen the four fixing screws (3) using a 5mm Allen key and remove the PSU.
6	Examine the removed PSU and identify the supply voltage for the WRH (13.5V or 27V).
7	Set the new PSU to the correct supply voltage by moving the jumper as illustrated on the PSU. This must be done before the PSU is mounted in the repeater.
8	Mount the PSU with the four fixing screws (3).
9	Connect the PSU to the DIA PCBA (2) with a cable marked VE007 98/1. This cable must be used even if one connector will be left over at the DIA PCBA (previous versions of the DIA had only one connector).
10	Connect the DC power cable. The supplied cable should have a radiation limiter. The + pole should be connected to one of the left terminals in the PSU connector with the brown part of the DC cable. The – pole should be connected to one of the right terminals in the PSU connector with the blue part of the DC cable.
11	Apply power and verify the yellow LED on the PSU lights.

Commissioning

Before proceeding, carefully read the Safety section and check all connections made during the installation. To fulfill the IP65 weather protective requirements, ensure cable strain relief bushings are properly tightened. Also, ensure gaskets at cable inlets and on the cabinet are properly fitted and not damaged.

A repeater can be configured locally with OM-Online by connecting a standard serial cable from the COM port on the PC to the P31 PC port (RS-232) located to the right in the cabinet as illustrated in Figure 3-15. The P31 PC port is described in Chapter 2. OM-Online is described in the *OM-Online User Manual*.

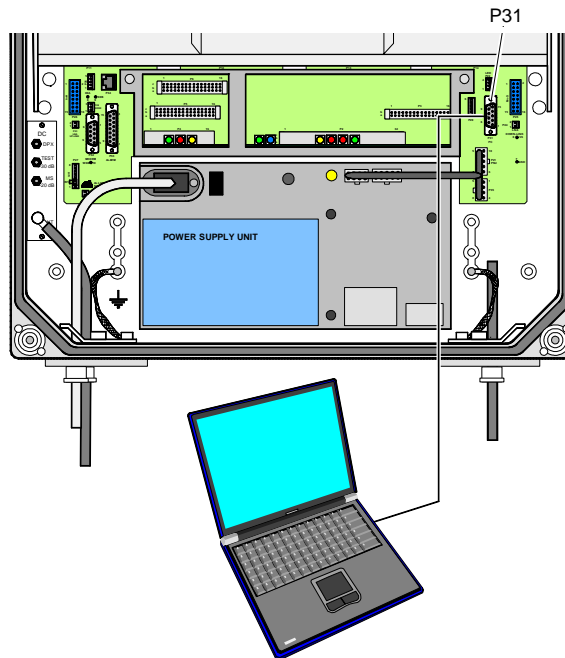

Figure 3-15 Connecting a PC for Local Access

For a BMU the PC is connected to the P106 port on the FON. The P106 port is described in the FON section in Chapter 2.

Initial Startup

Table 3-7 Initial Startup Procedure

Step	Action
1	Turn the main power on
2	Check the Yellow LED on the power supply unit. It must be a steady on
3	Check the four CU PCBA LEDs. Refer to the CU PCBA section in Chapter 2 for the correct power up indications
4	Check the three ALI PCBA LEDs or the corresponding LEDs on the RCI PCBA. Refer to the ALI or RCI PCBA section in Chapter 2 for the correct power up indications. The LEDs follow the alarm relays.

Measuring Output Signal Levels

Uplink and downlink output signal test ports are located on the DCs at the donor and service antenna connectors, provided the unit is configured with optional DCs. These test ports are labeled TEST -30dB as illustrated in Figure 3-16 and are intended for signal measuring using a spectrum analyzer.

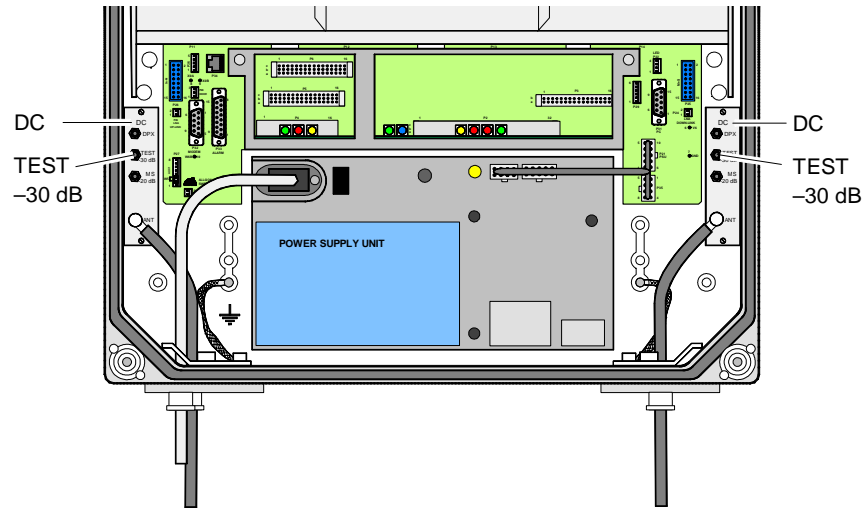

Figure 3-16 Output Signal Level Ports

The coupling is approximately -30dB. There is no directivity in these test ports; both uplink and downlink signal can be measured.

Voltage Testpoints

Testpoints are available on the DIA in the cabinet from which the various internal supply voltages can be measured using a standard multimeter. The testpoint positions and names are identified in the DIA section of Chapter 2.

Chapter 4 Maintenance

Introduction

This chapter contains periodic maintenance and performance test procedures for the AR Standard Repeater.

Periodic Maintenance

Periodic maintenance requirements are listed in Table 4-1, as well as the intervals at which the tasks should be performed.

Table 4-1 Recommended Periodic Maintenance

Task	Interval	Action
Inspection of cables and connectors	12 months	Inspect power, RF and Fiber cables for signs of damage or wear (frayed insulation, cracks, punctures, etc.) Check connections to be sure they are tight.
	Optional	Perform cable sweeps.
Clean equipment	Clean as required depending on operating environment.	

Troubleshooting

The sections that follow contain a list of problems that could occur and a few suggested actions that can correct the problem. If the suggested corrective action does not eliminate the problem, please contact your Powerwave field representative or help line for further instruction.

Clearing Alarm Faults

Table 4-2 contains a list of those alarms which can be generated in the repeater. Critical, Error and Warning alarms can be sent automatically from a repeater to OM-Online and/or OMS, stored and then viewed. These can be viewed in the Alarm window.

Table 4-2 Alarm Troubleshooting

ID	Alarm Text	Alarm Unit	Alarm	Description
1	Power	PSU	Critical	PSU1 in the cabinet does not work properly. A sum signal from the PSU1 indicates that at least one voltage output has dropped. If no mains breakdown relay is used, then the alarm will also be sent at mains breakdown.
			Ceasing	PSU1 in the cabinet works properly again. Ceasing is sent if the PSU1 works at start-up, and there is a corresponding critical PSU1 alarm logged in the Events log. The repeater will restart when the power is back and this alarm will be sent.

		PSU	Critical	PSU2 in the cover does not work properly. A sum signal from the PSU2 indicates that at least one voltage output has dropped. If no mains breakdown relay is used, then the alarm will also be sent at mains breakdown.
			Ceasing	PSU2 in the cover works properly again. Ceasing is sent if the PSU2 works at start-up, and there is a corresponding critical PSU2 alarm logged in the Events Log. The repeater will restart when the power is back and this alarm will be sent.
		FON	Error	The FON 10 Volt charger voltage is below limit. Suggested remedy: Replace the FON
			Ceasing	The cause of the alarm has ceased.
2	Repeater restart	CU	None	Power on start, or user ordered reboot. Logged to indicate a normal power up, or a restart ordered by the operator.
			Warning	Software error restart, 1st – 7th time. Restart 1st to 7th time during a 14 day period. The counter is reset every 14th day, counted from power up.
			Error	Software error restart 8th – 10th time. Restart 8th to 10th time during the 14 day period. At the 11th time, the SW bank will be blocked and not used anymore until a user ordered reset is performed, or power is switched off/on.
3	Mains breakdown	External	Critical	The mains power is gone. Used with an external relay indicating mains breakdown. The external relay should be connected to External Alarm 1 and the repeater configured to indicate this alarm. If no relay is used, a mains breakdown will be reported as a PSU fault.
			Ceasing	The mains power is back. Sent if there is a corresponding critical mains breakdown alarm logged in the Events Log. The repeater will restart when the power is back.
4	Alarm reset	CU	None	Alarm reset by the user. All alarms are reset. The cause of the alarm will be re-evaluated and reported, if still active.
5	Local bus error	CHA #, BSA#	Error	Error when communicating on the bus. The CU has no contact with the CHA or BSA PCBA, which is taken out of service.
6	Main bkd w backup	External	Error	Used to indicate that the mains is no longer available. Repeater is powered by external battery backup unit. Suggested remedy: Check the mains power.
			Ceasing	The cause of the alarm has ceased.
7	Err in AD-converter		Warning	The analog-to-digital converter on the CU PCBA does not give reliable values.
8	New unit detected		None	Compared to the last power on, the CU has recognized at least one additional hardware unit.

9	Inst. unit lost		Error	Compared to the last power on, the CU lacks at least one hardware unit.
10	EEPROM error	CU	Error	EEP read or write fail. Data cannot be written or read from the EEPROM on the CU PCBA. User parameters are stored in the EEPROM.
11	Log memory fault		Error	Log memory fault. Indicates that the log memory on the CU PCBA is faulty. The repeater will not work. Not available in all CU software versions.
12	High temperature	CU	Warning	The CU PCBA temperature is higher than 90°C.
			Ceasing	The CU PCBA temperature has fallen below 90°C.
13	REFO error		Error	AR: Significant REFO drift or error detected by CU. ALR: Low level from REFO detected by CU.
14	Ext refo error		Warning	Suggested remedy: Check the reference source and the cables.
15	CU battery fault	CU	Warning	CU RAM battery fault. The battery for the RAM on the CU PCBA has a voltage outside the normal 2.7 to 3.5 Volt. An alarm may be initiated at start-up if the repeater has been stored out of power for a long time. Suggested remedy: Ensure jumper P3 on the CU PCBA is mounted to charge the battery.
			Ceasing	The cause of the alarm has ceased.
16	SW load error	CU	Error	Software load error. An error has occurred during a software load process. The flash memory does not contain a proper software. Suggested remedy: Check the CU software using the OM-Online SW Manager. Do NOT restart the repeater.
17	Log cleared	CU	None	Log memory has been cleared. The check sum in the Events Log memory is faulty. The log is cleared. Can be caused of a bad RAM battery backup or low voltage to the RAM.
18	RTC restarted	CU	None	The time is changed by the operator (logged to keep track of changes made to the RTC).
			Warning	Time reset to 1994-01-01. The RTC was unable to keep track of the time and did a reset. Suggested remedy: Ensure jumper P3 on the CU PCBA is mounted to charge the battery.
19	RTC error		Error	RTC does not operate. The CU has detected an error in the RTC operation which makes the time unreliable. Suggested remedy: Replace the CU PCBA.
20	Door open alarm	External	Config	The door has been open 30 seconds without disabling the alarm.
			Ceasing	The door has been closed 30 seconds, or the alarm is disabled.

21	External alarm 1	External	Config	External alarm input EA1 active more than 1 second.
			Ceasing	External alarm input EA1 no longer active.
22	External alarm 2	External	Config	External alarm input EA2 active more than 1 second.
			Ceasing	External alarm input EA2 no longer active.
23	External alarm 3	External	Config	External alarm input EA3 active more than 1 second.
			Ceasing	External alarm input EA3 no longer active.
24	External alarm 4	External	Config	External alarm input EA4 active more than 1 second.
			Ceasing	External alarm input EA4 no longer active.
30	No modem found	Remote ctrl	None	No modem found, that is no answer is returned on a poll string to the modem.
33	No connection	Remote ctrl	None	No connection at callback. The repeater has tried to call as many times as stated in the alarm call settings. No connection was established.
			Warning	No connection at alarm call. The repeater has tried to call as many times as stated in the alarm call settings. No connection was established. This alarm does not generate a new attempt to report alarm by alarm call.
34	Login failed		None	Invalid repeater password.
35	Remote connection	Remote ctrl	None	Modem connection to OM-Online opened. Not logged on CU2. Login Registry gives the same function and more information about CU2.
36	Modem init failed	Remote ctrl	None	Initiation string to modem not OK. The initiation string sent to the modem is not OK. The string may contain commands not recognized by the modem. An alarm might be sent anyway. Suggested remedy: Check the modem using the OM-Online or OMS modem debugger.
37	Remote timeout	Remote ctrl	Warning	The time limit of 20 minutes is exceeded without extending the timer. The modem connection is terminated by the repeater.
38	PIN code failed	Remote ctrl	Warning	The PIN code sent to MS is incorrect. To unlock the MS/SIM card, the PUK code will probably be needed.
			Ceasing	The cause of the alarm has ceased.
39	No phone detected	Remote ctrl	Warning	When using a PC-card together with the MS, the alarm indicates contact with the PC-card, but MS is not present or turned off. Note: A Nokia MS does not power-up after power failure. Suggested remedy: Ensure the cellular phone is connected.

			Ceasing	The cause of the alarm has ceased.
40	Battery fault	RCU, FON charger	Error	The backup battery on the RCU or the FON PCBA does not work properly. Suggested remedy: Check cables or replace battery.
			Ceasing	The cause of the alarm has ceased.
41	RF blocking	Channel #, UL/DL	Error	Constant carrier, PA off. Uplink carrier has been constantly above 27dBm more than 10 seconds.
			Ceasing	The cause of the alarm has not been detected for 10 seconds.
42	Antenna isolation	BSA #, Channel #, UL/DL	Warning	Low antenna isolation. The antenna isolation is lower than the gain set. Gain is reduced by 10dB – 13dB below the oscillation point. Suggested remedy: Decrease gain or increase antenna isolation.
			Error	Low antenna isolation at lowest gain. The gain has been reduced as much as possible but the oscillation still remains. The amplifier is turned off. Suggested remedy: Decrease gain or increase antenna isolation.
			Ceasing	Normal operation again, that is no oscillation can be detected 13dB above the gain set.
44	Low stability margin	Channel #, UL/DL	Warning	MRX has detected that antenna isolation is below the gain set. The gain is reduced 10– 13dB below oscillation point. Suggested remedy: Decrease the gain or increase the antenna isolation.
			Ceasing	The cause of the alarm has ceased.
48	Battery backup fault	External	Error	If a battery backup unit alarm is connected to external alarm 2, then the operator can configure the repeater to display this alarm when the battery backup unit indicates alarm.
			Ceasing	The cause of the alarm has ceased.
50	Fiberoptical error	FOT fiber optics	Configurable	If a fiber unit alarm is connected to external alarm 3, then the operator can configure the repeater to display this alarm when the fiber optical unit indicates alarm.
			Ceasing	The cause of the alarm has ceased.
55	R2R Queue full	CU	None	R2R transmit queue is full, messages are lost. Suggested remedy: Check configuration and cables.
56	R2R Node lost	CU	None	An R2R node is lost. Suggested remedy: Check if node is still connected and operating.
			Warning	An R2R node is lost. Suggested remedy: Check if node is still connected and operating.
57	R2R HW Error	RIA	Error	R2R HW failure because the CU cannot read the MAC-ID of the RIA PCBA or any other HW error in the R2R logic. Suggested remedy: Replace the RIA PCBA.

		BSC R2R	Error	R2R HW failure because the CU cannot read the MAC-ID or any other HW error in the R2R logic. Suggested remedy: Replace the repeater.
		FON R2R FO	Error	R2R HW failure because the CU cannot read the MAC-ID or any other HW error in the R2R logic. Suggested remedy: Replace the FON PCBA.
60	Low traffic activity	RSSI Statistics	Warning	No signal strength on the channel was above the limit set longer than the time set in the configuration, indicating possible problems with service antenna. The area that the repeater is servicing may be covered by another stronger repeater or BTS. Suggested remedy: Ensure that the antennas and the cellular phone work in the area to be covered, and that repeater supported channels are used.
			Ceasing	The cause of the alarm has ceased.
61	No BCCH detected	RSSI Statistics	Warning	Signal strength on the BCCH channel was below the limit set longer than the time set in the configuration, indicating possible malfunction in the BTS or donor antennas. Suggested remedy: Ensure that the repeater is configured to the BCCH channel and that the signal from the BTS has enough strength.
			Ceasing	The cause of the alarm has ceased.
65	Gain reduction	Channel #, UL/DL	Warning	The gain is reduced below the limit. The gain is reduced because the output power has been above the MPC limit more than the preset limit allows.
			Ceasing	The cause of the alarm has ceased.
66	Over-power alarm	Channel #, UL/DL	Warning	Input power too high, output power above maximum limit.
			Ceasing	The cause of the alarm has ceased.
70	Bad table alarm	CU	Error	Requested table contains incorrect information (SW error).
71	Table not found	CU	Error	Requested table not found in the database (SW or calibration error).
72	Table database error	CU	Error	Table database not found (calibration error).
80	Antenna SWR alarm	Donor antenna, service antenna	Error	Too low antenna return loss, caused either by cables, connectors, or antenna problems. Suggested remedy: Check antenna and cables.
			Ceasing	The cause of the alarm has ceased.

90	FON power alarm	FON RF	Error	A DC voltage on a FON PCBA is out of range. Suggested remedy: Replace the FON PCBA.
			Ceasing	The cause of the alarm has ceased.
91	FON TxStable alarm	FON RF	Error	Laser transmitter control loop voltage out of range. Suggested remedy: Replace the FON PCBA.
			Ceasing	The cause of the alarm has ceased.
92	FON RxLevel alarm	FON	Warning	Received optical level is below any of the two limits (one for Warning and one for Error). Suggested remedy: Check optical cables.
			Error	Received optical level is below any of the two limits (one for Warning and one for Error). Suggested remedy: Check optical cables.
			Ceasing	The cause of the alarm has ceased.
93	FON SPI alarm	FON F2F	Error	The SPI bus connection to the RF modem does not work properly. Suggested remedy: Replace the FON PCBA.
97	No GPS signal	GPS	Warning	The GPS device cannot find any satellites. If active antenna is used, then the power supply for it can be faulty or wrongly configured. Suggested remedy: Check the GPS antenna and cables. If an active antenna is used, then the jumper switch should be set accordingly.
			Ceasing	The cause of the alarm has ceased.
98	No GPS device	GPS	Error	The GPS device cannot be detected although an adapter PCBA is mounted. Suggested remedy: Check the GPS PCBA.
			Ceasing	The cause of the alarm has ceased.
99	GPS Antenna power	GPS	Error	The power supply to the GPS antenna is faulty or there is a power supply to a passive antenna. Suggested remedy: Check the GPS antenna and cables. If an active antenna is used, then the jumper switch should be set accordingly.
			Ceasing	The cause of the alarm has ceased.
100	Startup error	CHA #	Error	A hardware error is detected on the PCBA at powering up.
101	Synthesizer fault	CHA #	Error	Unlocked synthesizer. The frequency synthesizer is unlocked and the transmission can take place on an unknown frequency.
102	Volt Reg. fault	CHA #	Error	DC voltage missing. A DC voltage to an analog part of the PCBA is missing.
103	PA fault	CHA #	Error	Low power amplifier gain. The PA PCBA has too low output power for the RSSI and gain set. Not available in all CU software versions.

104	Param R/W error	CHA #	Error	EEPROM read or write failure on the PCBA.
105	High temperature	CHA #	Warning	The CHA PCBA temperature is higher than 85°C.
			Error	The CHA PCBA temperature is higher than 95°C.
			Ceasing	The CHA PCBA temperature has fallen below 70°C.
110	SW incompatibility	MRX	Error	The MRX and CU software is not compatible. Suggested remedy: Check the software versions and replace the incompatible one.
120	Startup error	BSA #	Error	A hardware error is detected on the BSA PCBA at powering up.
121	Synthesizer fault	BSA #	Error	Unlocked synthesizer. The frequency synthesizer is unlocked and the transmission can take place on an unknown frequency.
122	Volt Reg fault	BSA #	Error	A DC voltage to an analog part of the PCBA is missing.
123	PA fault	BSA #	Error	Low power amplifier gain. The PA PCBA has too low output power for the RSSI and gain set. Not available in all CU software versions.
124	Param R/W fault	BSA #	Error	EEPROM read or write failure on the BSA PCBA.
125	High temperature	BSA #	Warning	The BSA PCBA temperature is higher than 85°C.
			Error	The BSA PCBA temperature is higher than 95°C and the power is turned off.
			Ceasing	The temperature has fallen to below 70°C and the power is turned on again.
126	High PSU voltage	BSA #	Critical	The PA supply voltage is too high. Suggested remedy: Ensure that correct PSU is used.
127	Unsupported PA-type	BSA #	Error	The ID of the mounted PA PCBA is not expected by the BSA PCBA. Suggested remedy: Ensure that correct PA PCBA is used.
128	BA HW alarm	BA #	Error	A HW error on the BA PCBA has been detected.
			Ceasing	The BA PCBA is working properly after failure.
129	PA Under-voltage alarm	PA/BA #	Error	PA voltage level below alarm limit. Suggested remedy: Check the PSU.
			Ceasing	The cause of the alarm has ceased.
		BSC, UL/DL	Error	PA voltage level below alarm limit. Suggested remedy: Check the PSU.
			Ceasing	The cause of the alarm has ceased.

245	Not In Allowed Area	CU	None	Repeater is moved from the operating area and the RF HW is switched on or off.
-----	---------------------	----	------	--

Remarks:

The Door open alarm requires an optional door switch described in the P33 Alarm Port section in Chapter 3.

The Main Power Breakdown alarm requires a relay not included in the repeater (see Main Power Breakdown Relay in Chapter 3).

Channel #, UL/DL Repeater channel number (1-4) at CSEL operation, uplink or downlink.

BSEL #, UL/DL Repeater channel number at BSEL operation, uplink or downlink.

BA #, BA PCBA number for high power operation.

BSA #, BSA PCBA number for BSEL operation.

CHA #, CHA PCBA number for CSEL operation.

CSA #, CSA PCBA number for CSEL CDMA operation.

FON, FON PCBA for fiber optic communication.

PA, PA PCBA for CSEL or BSEL operation.

Field Replaceable Units

The following units can be replaced in the field on-site by a qualified technician with experience maintaining RF equipment:

- FON
- PSU
- AR Repeater

FON

To replace a FON PCBA, proceed as described in the Table 4-3.

Table 4-3 FON Replacement Procedure

Step	Action
1	Open repeater door and secure
2	Locate power connector on FON and remove connector from PCBA
3	Verify all cables on FON are labeled before disconnecting, then disconnect all cables
4	Remove screws securing FON PCBA to FOU and remove PCBA
5	Replace FON PCBA in reverse order and apply power
6	Connect PC to OM Online port, login to FON and verify configuration and IP address. NOTE: Make sure 'Fiberoptical' classmark in the FON Status window is checked, otherwise FON will not be operational.
7	Close repeater door and secure

PSU

To replace a PSU, proceed as described in the Table 4-4.

Table 4-4 PSU Replacement Procedure

Step	Action
1	Open repeater door and secure
2	Disconnect main power plug from PSU
3	Disconnect power cable bundle from PSU
4	Loosen screws securing PSU using a 5mm Allen key and remove. NOTE: screws are designed to not be removed completely from PSU.
5	Replace PSU in reverse order and apply power
6	Close repeater door and secure

Repeater

To replace an AR repeater, proceed as described in the Table 4-5.

Table 4-5 Repeater Replacement Procedure

Step	Action
1	Open repeater door and secure
2	Disconnect main power plug from PSU
3	Verify all cables connected to repeater are labeled before disconnecting, then disconnect all cables
4	Remove mounting screws from bottom legs of repeater and loosen mounting screws in top legs
5	Close and secure door
	WARNING: A fully loaded AR Repeater can weigh 75lbs. Lifting of the repeater should be done by two people. Do not attempt to carry the repeater up a ladder.
6	Lift the repeater off the mount hinges
7	Replace repeater in reverse order
8	Connect PC to OM Online port and verify configuration. For Fiber Optic installations, verify IP address. NOTE: Make sure 'Repeater On' classmark in the BSEL Status window is checked, otherwise the repeater will not be operational.
9	Close repeater door and secure

Return For Service Procedures

When returning products to Powerwave, the following procedures will ensure optimum response.

Obtaining an RMA

A Return Material Authorization (RMA) number must be obtained prior to returning equipment to the factory for service. Please contact our Repair Department at 1-714-466-1000 to obtain this number, or FAX your request to 1-714-466-5800. Failure to obtain this RMA number may result in delays in receiving repair service.

Repackaging for Shipment

To ensure safe shipment of the unit, it is recommended that the original package designed for shipping the unit be reused. If it is not available, contact Powerwave's Customer Service Department for packing materials.

Options

This chapter describes the following optional accessories available for the Powerwave repeaters:

- Remote Control Unit (RCU) including the old RCU for GSM 900/1800/1900
- Repeater To Repeater Link (R2R)
- Traffic Statistics
- Battery Backup
- 7/16" Antenna Cable Connectors
- Operation and Maintenance System (OMS)

Remote Control Unit (RCU)

The RCU provides remote control of Powerwave repeaters. It contains an integrated mobile phone, modem and power supply backup. The RCU is installed in the bottom front of the cabinet, on top of the PSU as illustrated in Figure 4-1.

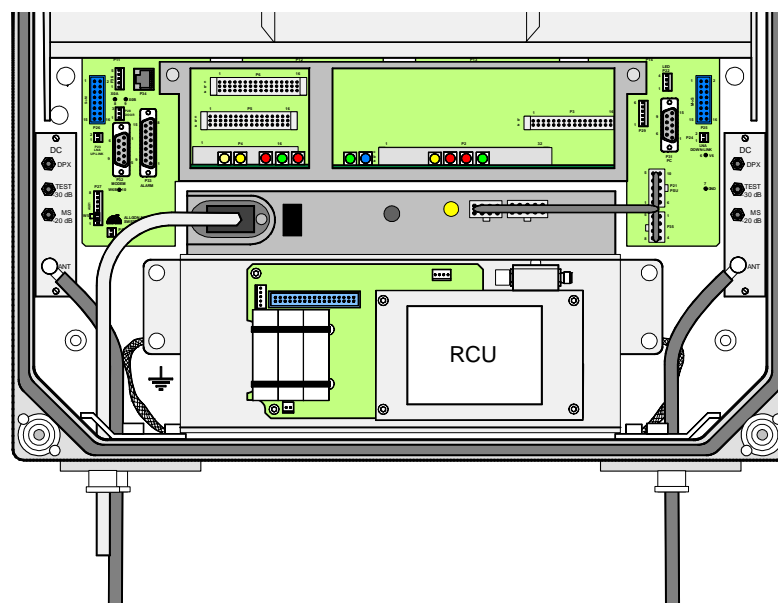

Figure 4-1 RCU Location

The RCU is connected to P130 on either an RCI or FON. A jumper is required between pins 1 and 2 on the RCI if the P130 cable connector is disconnected. If a main power failure occurs, the unit has a battery with enough capacity for sending a number of alarms.

Previous RCU versions have been replaced by the current type. The repeaters are compatible with the previous version. Differences apply to the connections of the previous version where data was transferred between the repeater and the RCU via the P32 modem port on the DIA and was powered via the P27 auxiliary port on the DIA.

RCU for Radio Communication

The RCU antenna for a radio modem is connected to the BS antenna via the uplink DC, provided the RCU and the repeater operate in the same cell system. Otherwise, the modem must have a separate antenna. Data is transferred between the repeater and the RCU via the P130 modem port on the RCI or FON. The RCU is also powered via the same port and has a battery with enough capacity to send a number of alarms if a main power failure occurs.

RCU for Telephone Line Communication

The land line version uses a telephone line connected to a terminal block on the RCU. A free strain relief bushing at the bottom of the repeater is used for the external telephone line cable.

Previous RCU Version for GSM 900/1800/1900

This description is for reference use only. This RCU is replaced by the current version and consists of an integrated mobile phone/modem, power supply and power supply backup. It was located inside the repeater cabinet, in front of the PSU as illustrated in Figure 4-2.

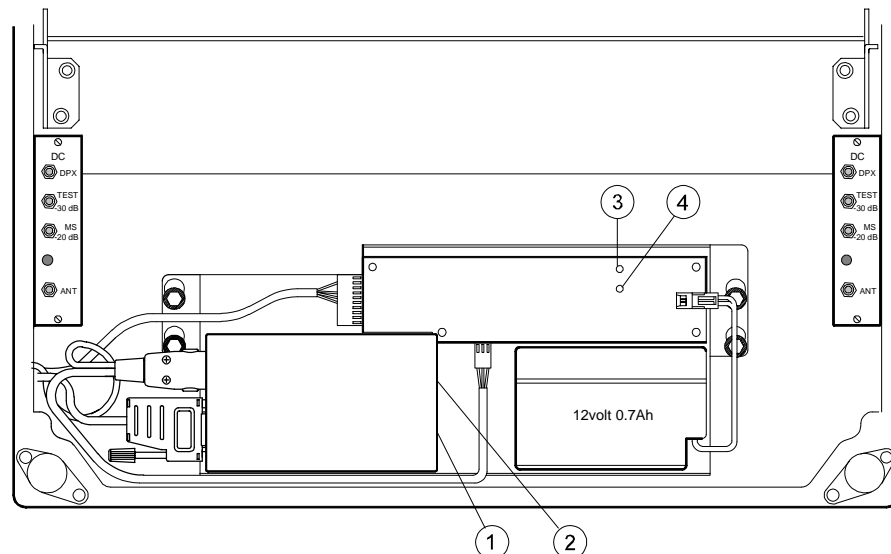

Figure 4-2 RCU – GSM 900 type

The RCU was connected to P27, P32, and the MS -20dB port. The following callout numbers refer to the numbers in Figure 4-2.

1. The GSM PCBA. Press a pencil or similar object on the small button adjacent to the SIM PCBA to release it.
2. The LED indicator on the phone/modem unit that shows three operational modes:
 - Out: The unit is off
 - Slow flashing: Stand by

Fast flashing: Connection in progress

3. Green LED on the battery charger which is lit steady when the power supply is OK either from the main input power or from the battery.

4. Yellow LED on the battery charger which is lit steady during battery charge from the main input power.

A jumper is required between pins 2 and 3 on the P27 connector if the RCU is disconnected from the DIA.

GSM subscriber conditions

Data rate = 9600 bps, transparent mode. If the PIN code has to be disabled, use another phone. If you encounter problems with the PIN code, contact Powerwave Technical Support.

Power supply backup

If a power failure occurs the backup battery has capacity to supply the CU, ALI and phone/modem for 30 minutes at room temperature and a limited number of call attempts. The battery life is 1 - 2 years at normal indoor temperature. If the operational temperature is higher, the battery life is shortened.

Repeater-to-Repeater Link (R2R)

This section briefly describes the R2R network. Node configuration for the R2R network is described in the OM-Online User's Manual.

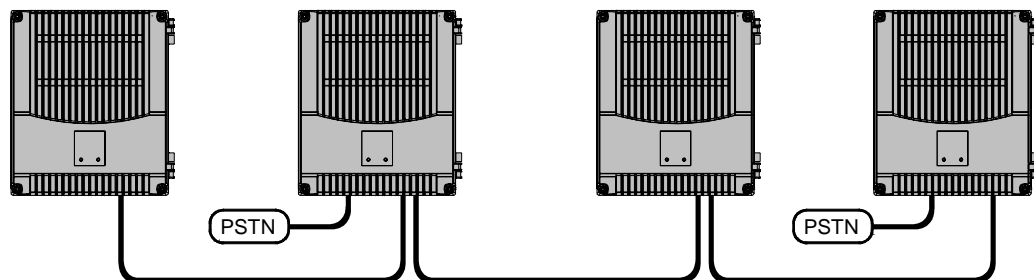

Figure 4-3 R2R network

The R2R network is a Powerwave specific repeater network that can handle up to 13 nodes, one or several of which being gateway repeaters for communication with OM-Online or OMS via modem. Powerwave repeaters produced after January 2005 have the R2R functionality. Repeaters produced prior to this date can be upgraded with an R2R network kit provided the repeaters meet the following requirements:

Hardware

DIA PCBAK105/1 version R2A or higher

RIA PCBA The RIA PCBA is required if the K105/1 DIA PCBA has a version lower than R3A.

CU PCBAK103/2 version R1A or higher

Software

CUSA102 02/1 version R3A or higher

Information for upgrades is located in the R2R, Repeater to Repeater Link Kit, Installation Guide. (part # VD202 91/EN).

Protocol

Sliding Window (SLW) is a Powerwave specific protocol developed for the R2R network. The SLW protocol and the IP protocol do not support each other and they cannot be mixed in any node.

Traffic Statistics

Traffic statistics are available for channel selective EDGE/GSM 900, GSM 1900 and DCS/PCN 1800 repeaters, provided the repeaters have the latest CU software version, the latest CU and CHA PCBAs, and an OMS is used to poll and view the statistics.

Battery Backup (BBU)

Battery backup is available with a Powerwave BBU battery backup. The BBU has an exterior similar to the repeater.

7/16" Antenna Cable Connectors

A 7/16" antenna cable kit is available for all the Powerwave repeaters. This kit includes 7/16" antenna connectors for UL and DL antennas mounted on two repeater cable inlet flanges and cables and connectors for connection to the DCs inside the repeater.

Operation and Maintenance System (OMS)

OMS is a Powerwave software package for repeater fleet management. Multiple modems can be used for several incoming and outgoing parallel activities, such as alarm reception, radio parameter configuration and software downloading.

OMS has also ability to schedule activities.

Chapter 5 Specifications

Introduction

This chapter provides specifications for the AR Standard Repeater product line.

Table 5-1 AR Standard Repeater Specifications

Generic	
Dimensions (W x H x D in inches)	17.5 x 21 x 7 (low cover) 17.5 x 21 x 11 (high cover)
Weights: Empty low cover Repeater with a low cover Combined repeater with a high cover Equipped cabinet or high cover w/extra heat sink element	13 lbs (6.0 kg) 50 lbs (22.5 kg) 82 lbs (37.0 kg) 41 lbs (18.5 kg)
Temperature range	-13 to +131°F (-25 to + 55°C)
Casing class	NEMA4/IP65
Fiber Optic Link Budget	15dB _o
Amplifiers in 1 cabinet	Standard = 2; High Power = 4
Receiver input port return loss	14dB
Power supply voltage (default)	115 VAC
Power consumption, max	160 W

AR1200 Family - GSM 900 Band Selective	
Frequency band UL	890-915 MHz
Frequency band DL	935-960 MHz
Number of channels	N/A
Absolute group delay	6 μs
Filter bandwidth (remotely adjustable)	0.5-16.9 MHz, remote adjustable
Gain adjustment range (in 1 dB steps)	45-85dB
Gain (max variation -25 to +55 °C)	6dB
Pass band ripple	4dB
Maximum input power (non-destructive)	+13dBm
Output power RMS, one carrier, DL	+26dBm (+29dBm PEP)
Noise figure at 85 dB gain, 25° C (typical)	6dB

AR1700 Family - GSM 900 Channel Selective	
Frequency band UL	890-915 MHz
Frequency band DL	935-960 MHz
Number of channels	1 to 8
Absolute group delay	5 μ s
Filter bandwidth (remotely adjustable)	200 KHz
Gain adjustment range (in 1 dB steps)	55-90dB
Gain (max variation -25 to +55 °C)	4dB
Pass band ripple	3dB
Maximum input power (non-destructive)	+13dBm
Output power RMS, one carrier, DL	+33dBm
Noise figure at 85 dB gain, 25° C (typical)	4dB

AR2100/2700 Family - GSM 1800 Channel Selective	
Frequency band UL	1710-1785 MHz
Frequency band DL	1805-1880 MHz
Number of channels	1 to 8
Absolute group delay	5 μ s
Filter bandwidth (remotely adjustable)	200 KHz
Gain adjustment range (in 1 dB steps)	55-90dB
Gain (max variation -25 to +55 °C)	4dB
Pass band ripple	3dB
Maximum input power (non-destructive)	+13dBm
Output power RMS, one carrier, DL	+32dBm
Noise figure at 85 dB gain, 25° C (typical)	4dB

AR2200 Family - GSM 1800 Band Selective	
Frequency band UL	1710-1785 MHz
Frequency band DL	180-1880 MHz
Number of channels	N/A
Absolute group delay	6 μ s
Filter bandwidth (remotely adjustable)	0.5-16.9 MHz, remotely adjustable
Gain adjustment range (in 1 dB steps)	45-85dB

Gain (max variation -25 to +55 °C)	6dB
Pass band ripple	5dB
Maximum input power (non-destructive)	+13dBm
Output power RMS, one carrier, DL	+29dBm (+32dBm PEP)
Noise figure at 85 dB gain, 25° C (typical)	6dB

AR3100/3700 Family - GSM 1900 Channel Selective	
Frequency band UL	1850-1910 MHz
Frequency band DL	1930-1990 MHz
Number of channels	1 to 8
Absolute group delay	5 μs
Filter bandwidth (remotely adjustable)	200 KHz
Gain adjustment range (in 1 dB steps)	55-90dB
Gain (max variation -25 to +55 °C)	4dB
Pass band ripple	3dB
Maximum input power (non-destructive)	+13dBm
Output power RMS, one carrier, DL	+32dBm
Noise figure at 85 dB gain, 25° C (typical)	4dB

AR3400 Family - GSM 1900 Band Selective	
Frequency band UL	1710-1785 MHz
Frequency band DL	1805-1880 MHz
Number of channels	N/A
Absolute group delay	6 μs
Filter bandwidth (remotely adjustable)	0.5-16.8 MHz, remotely adjustable
Gain adjustment range (in 1 dB steps)	45-85dB
Gain (max variation -25 to +55 °C)	6dB
Pass band ripple	5dB
Maximum input power (non-destructive)	+13dBm
Output power RMS, one carrier, DL	+33dBm (+36dBm PEP)
Noise figure at 85 dB gain, 25° C (typical)	6dB

AR1700/902 Family - EGSM 900 Channel Selective	
Frequency band UL	880-915 MHz
Frequency band DL	925-960 MHz
Number of channels	1 to 8
Absolute group delay	<5 μ s
Gain adjustment range (in 1 dB steps)	55-90dB
Gain (max variation -25 to +55 °C)	4dB
Pass band ripple	1dB
Maximum input power (non-destructive)	+13dBm
Output power RMS, one carrier, DL	+33dBm
Noise figure at 85 dB gain, 25° C (typical)	4dB

AR1100/802 Family - RGSM 900 Channel Selective	
Frequency band UL	876-880 MHz
Frequency band DL	921-925 MHz
Number of channels	1 to 4
Absolute group delay	<5 μ s
Gain adjustment range (in 1 dB steps)	55-90dB
Gain (max variation -25 to +55 °C)	4dB
Pass band ripple	1dB
Maximum input power (non-destructive)	+13dBm
Output power RMS, one carrier, DL	+33dBm
Noise figure at 85 dB gain, 25° C (typical)	4dB

AR6500 Family - WCDMA Channel Selective	
Frequency band UL	1920-1980 MHz
Frequency band DL	2110-2170 MHz
Number of channels	1 to 2
Absolute group delay	6 μ s
Filter bandwidth (remotely adjustable)	5 MHz
Gain adjustment range (in 1 dB steps)	60-90dB
Gain (max variation -25 to +55 °C)	4dB
Pass band ripple	2dB within 4 MHz

Maximum input power (non-destructive)	+13dBm
Output power RMS, one carrier, DL	+30dBm; Standard AR6500
Output power RMS, one carrier, UL	+20dBm
Output power RMS, one carrier, DL	+38dBm; High Power AR6560
Noise figure at 85 dB gain, 25° C (typical)	3dB

AR3400 Family – TDMA/CDMA Band Selective	
Frequency band UL	1850-1910 MHz
Frequency band DL	1930-1990 MHz
Absolute group delay	6 μ s
Filter bandwidth (remotely adjustable)	0.5-16.9 MHz
Gain adjustment range (in 1 dB steps)	45-85dB
Gain (max variation –25 to +55 °C)	6dB
Pass band ripple	5dB
Maximum input power (non-destructive)	+13dBm
Output power RMS, one carrier, DL	+33dBm (+36dBm PEP)
Output power RMS, one carrier, UL	+33dBm (+36dBm PEP)
Output power RMS, one carrier, DL	+36dBm (+39dBm PEP) AR4240
Noise figure at 85 dB gain, 25° C (typical)	6dB

AR4200 Family – AMPS Band Selective	
Frequency band UL	824-849 MHz
Frequency band DL	869-894 MHz
Absolute group delay	6 μ s
Filter bandwidth (remotely adjustable)	0.5-16.9 MHz
Gain adjustment range (in 1 dB steps)	45-85dB
Gain (max variation –25 to +55 °C)	6dB
Pass band ripple	5dB
Maximum input power (non-destructive)	+13dBm
Output power RMS, one carrier, DL	+33dBm (+36dBm PEP) AR4200
Output power RMS, one carrier, UL	+33dBm (+36dBm PEP)
Output power RMS, two carrier, DL	+36dBm (+39dBm PEP) AR4240
Noise figure at 85 dB gain, 25° C (typical)	6dB

AR4600 Family – iDEN/SMR Band Selective	
Frequency band UL	806-824 MHz
Frequency band DL	851-869 MHz
Absolute group delay	6 μ s
Filter bandwidth (remotely adjustable)	0.5-16.9 MHz
Gain adjustment range (in 1 dB steps)	45-85dB
Gain (max variation -25 to +55 °C)	6dB
Pass band ripple	5dB
Maximum input power (non-destructive)	+13dBm
Output power RMS, one carrier, DL	+33dBm (+36dBm PEP) AR4200
Output power RMS, one carrier, UL	+33dBm (+36dBm PEP)
Output power RMS, two carrier, DL	+36dBm (+39dBm PEP) AR4240
Noise figure at 85 dB gain, 25° C (typical)	6dB

The output signal from the mixer is then amplified in the PA and fed to a combiner which combines the signals from the two channels on the CSA. The output signal passes a CMB and DPX before it is fed to the repeater service antenna.

CSeI CDMA/WCDMA Repeater

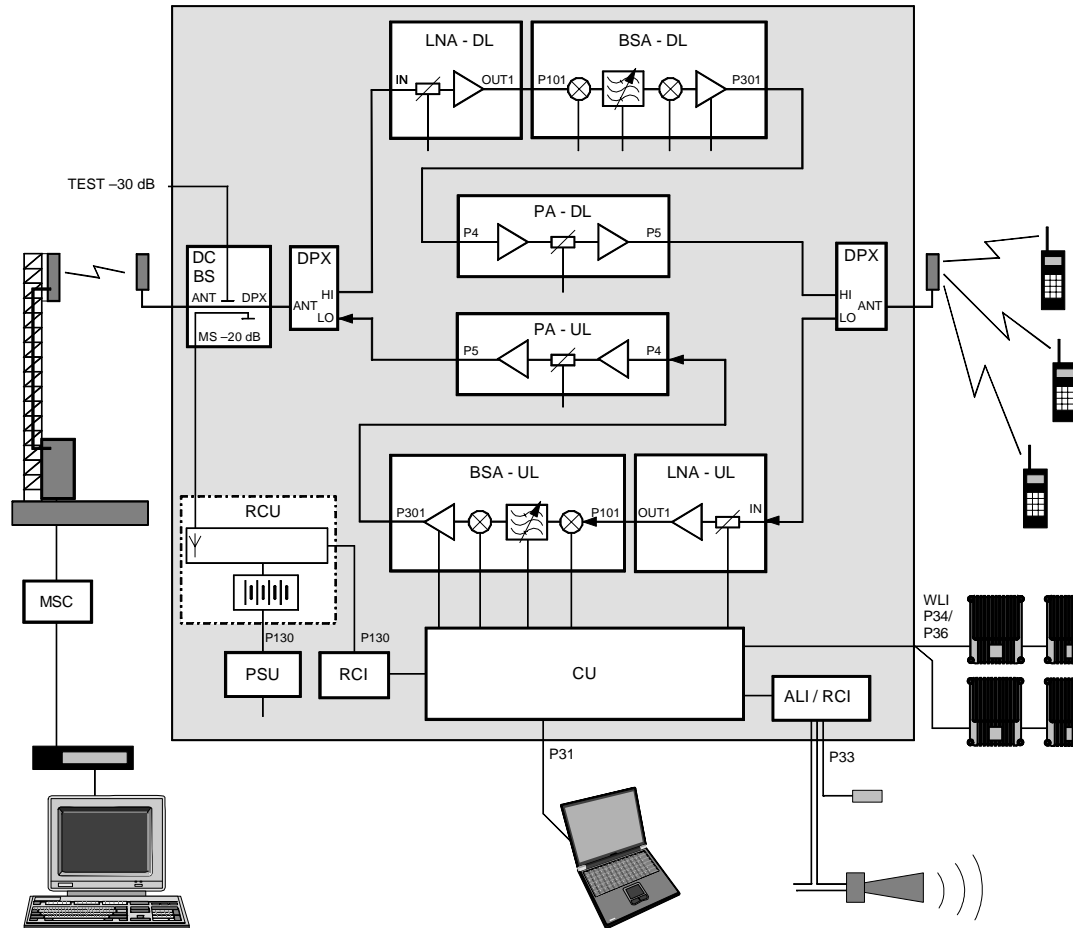

Figure A-2 CSeI CDMA/WCDMA Repeater Block Diagram

Figure A-2 illustrates a block diagram of a CSeI CDMA or WCDMA repeater. The signal from the base station is received via the repeater donor antenna and is forwarded through a DC, used as antenna port only if an RF modem is used. The signal passes a DPX, is amplified in a LNA, and enters the CSA which has two parallel channels.

The first mixer stage on the CSA, which is controlled by a synthesizer, converts the received frequency down to the IF frequency. The signal is then filtered by SAW bandpass filters and amplified before it is fed to the second mixer stage for conversion back to the original frequency. The following amplifier on the CSA is controlled by the CU. The output gain can be reduced to avoid instability due to poor antenna isolation by means of a gain control in the CU. The gain control also affects other amplification stages. The output signal from the amplifier is fed to a combiner which combines the signals from the two channels on the CSA. The signal from the CSA is amplified on the PA and then fed to a DPX or, in high power CDMA repeaters, to a BA. The amplified output signal passes the DPX before it is fed to the repeater service antenna.

In high power CDMA or WCDMA repeaters, a BA boosts the output DL signal from the PA by typically 6dB. The amplified signal is fed to the DPX at the service port. Only the DL path has a BA which is powered by a second PSU.

RMU

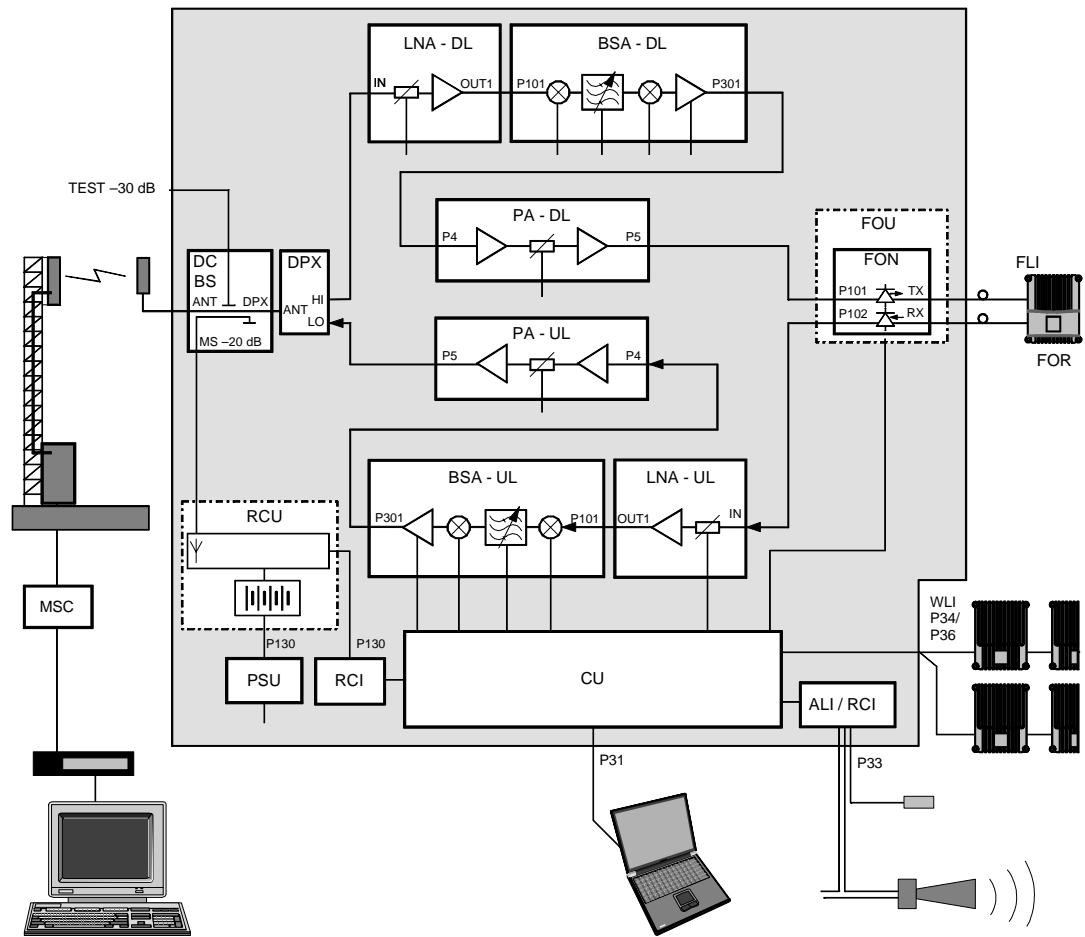

Figure A-5 RMU Block Diagram

Figure A-5 illustrates a block diagram of an RMU for band selective operation. This diagram is identical to the block diagram of the band selective repeater except for the FOU and the fiber optic connection to a FOR.

The output signal from the PA at P5 enters the FON which converts the RF signal to an optical signal. The FON supervises the signaling and reports errors via the RCU connected to the CU. The optical signal from the TX output is sent via a fiber optic cable to a FOR.

FOR

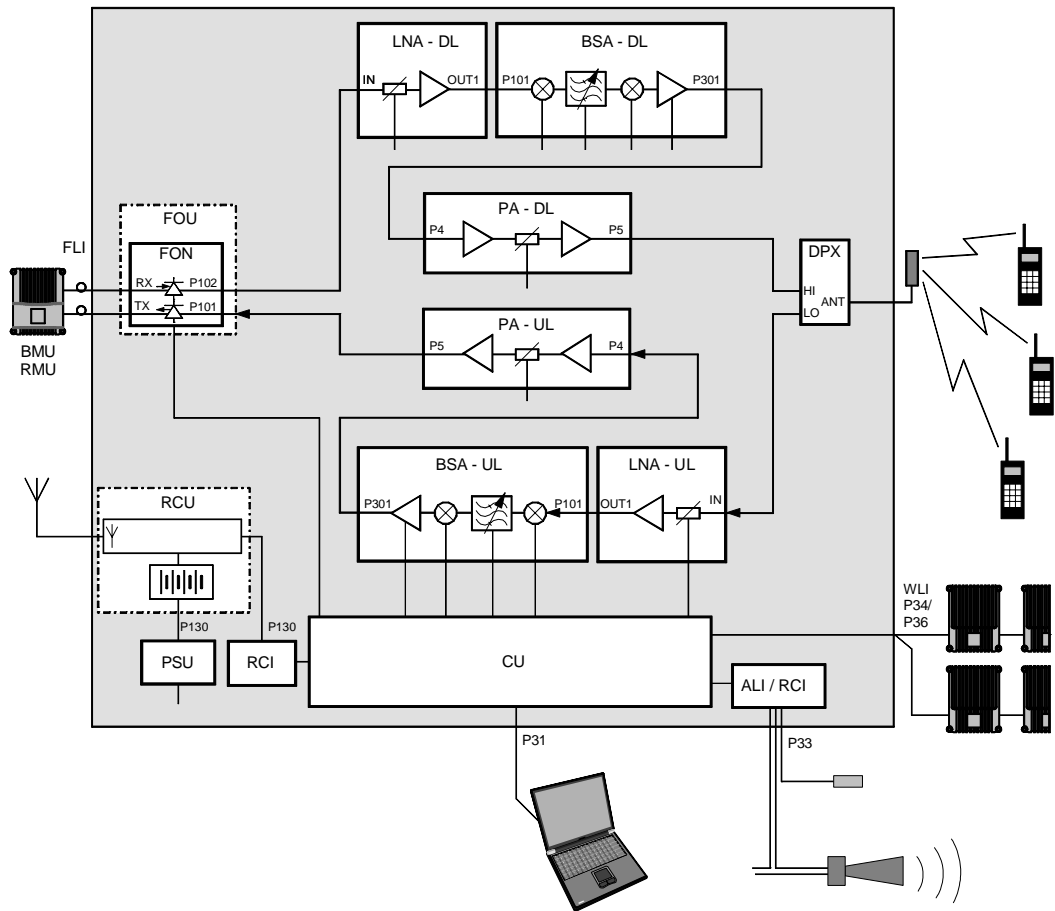

Figure A-6 FOR Block Diagram

Figure A-6 illustrates a block diagram of a FOR with band selective operation. The diagram is identical to the block diagram of the band selective repeater except for the FOU and the fiber optic connection to the BMU, RMU or FOR.

The signal from a BMU, RMU or FOR is received via a fiber optic cable and is fed to the FON on the FOU. The FON converts the optic signal to an RF signal, supervises the signaling and reports errors via the RCU connected to the CU. The RF signal is then fed to the DL LNA.



Powerwave Installation and Service Manual

Corporate Headquarters
Powerwave Technologies, Inc.
1801 East St. Andrew Place
Santa Ana, CA 92705 USA

Tel: 714-466-1000
Fax: 714-466-5800
www.powerwave.com

Main European Office
Antennvägen 6
SE-187 80 Täby
Sweden
Tel: +46 8 540 822 00
Fax: +46 8 540 823 40

Main Asia-Pacific Office
23 F Tai Yau Building
181 Johnston Road
Wanchai, Hong Kong
Tel: +852 2512 6123
Fax: +852 2575 4860