

PAF

INDOOR MCPA PLATFORM

INSTALLATION AND SERVICE MANUAL

PAF-19XX-EX-XXX



© 2007 Powerwave Technologies Incorporated. All rights reserved.

Powerwave Technologies, and the Powerwave logo are registered trademarks.

This Powerwave product is intended only for installation in a RESTRICTED ACCESS LOCATION and is designed to operate within the Normal Operating (typical operating) ranges or conditions specified in this document. Operation of this equipment beyond the specified ranges in this document may cause:

1. Spurious emissions that violate regulatory requirements.
2. The equipment to be automatically removed from service when maximum thresholds are exceeded.
3. The equipment to not perform in accordance with its specifications.

It is the Operator's responsibility to ensure this equipment is properly installed and operated within Powerwave operating specifications to obtain proper performance from the equipment and to comply with regulatory requirements.

For PERMANENTLY CONNECTED EQUIPMENT, a readily accessible disconnect device shall be incorporated in the building installation wiring.

Warnings, Cautions, and Notes

Warnings, Cautions, and Notes are found throughout this manual where applicable. The associated icons are used to quickly identify a potential condition that could result in the consequences described below if precautions are not taken. Notes clarify and provide additional information to assist the user.



WARNING: This warning symbol means danger. You are in a situation that could cause bodily injury. Before you work on any equipment, be aware of the hazards involved with electrical and RF circuitry and be familiar with standard practices for preventing accidents



CAUTION: This caution symbol means reader be careful. In this situation, the user might do something that could result in equipment damage or loss of data.

NOTE This note symbol means reader take note. Notes contain helpful suggestions or references to material not covered in the document. Procedures are not contained in notes.

Revision Record

Revision Letter	Date of Change	Reason for Change
A	November 2007	Initial release

Table of Contents

Chapter 1 - Product Description

Introduction	1-1
Scope of Manual	1-1
Product Description	1-1
Functional And Physical Specifications	1-1

Chapter 2 - Controls and Indicators

Introduction	2-1
Subrack	2-1
Ethernet Connector Pinout	2-2
RS-485 Interface	2-3
Filter I/O (if used)	2-3
MCPA	2-3
Filter (if used)	2-4
Circuit Breaker Panel	2-6

Chapter 3 - Installation

Introduction	3-1
Site Survey	3-1
Space Requirements	3-1
Unpacking and Inspection	3-1
Electrical Service Recommendations	3-1
Cooling Requirements	3-2
Installation Instructions	3-2
PAF	3-2
Seismic Brace (Optional)	3-3
DC Connections	3-3
RS-485 Alarm Interface	3-5
MCPA	3-5
Initial Start-Up and Power Setting Procedures	3-6
Initial Start Up	3-6

Chapter 4 - Maintenance

Introduction	4-1
Periodic Maintenance	4-1
Troubleshooting	4-1
Clearing Alarm Faults	4-2
System Component Part Numbers	4-2
Field Replacement Procedures	4-2
MCPA	4-3
Subrack Cooling Fans	4-4
Inside Mount	4-4
Rear Mount	4-5
Fan Inside Mount to Rear Mount Conversion	4-6
Subrack	4-7
Filter	4-8
Circuit Breaker Panel	4-9
Return For Service Procedures	4-10
Obtaining An RMA	4-10
Repackaging For Shipment	4-10

Chapter 5 - Specifications

Introduction	5-1
--------------------	-----

List of Tables

2-1 Subrack Faceplate Interface Connectors, and Indicators	2-2
2-2 Ethernet Connector Pinout.....	2-2
2-3 RS-485 Pinout.....	2-3
2-4 MCPA Indicators and Controls.....	2-4
2-5 Filter Connector Descriptions.....	2-5
3-1 Sample of DC Cable Ratings	3-2
3-2 PAF Frame Installation Procedure.....	3-3
3-3 DC Power Installation Procedure.....	3-4
3-4 RS-485 Alarm States	3-5
3-5 MCPA Installation Procedure.....	3-6
3-6 Initial Startup Procedure	3-6
4-1 Periodic Maintenance	4-1
4-2 Troubleshooting	4-2
4-3 System Components Part Number List.....	4-2
4-4 MCPA Removal and Replacement Procedure.....	4-3
4-5 Inside Mount Cooling Fan Removal and Replacement Procedure	4-4
4-6 Rear Mount Cooling Fan Removal and Replacement Procedure.....	4-5
4-7 Fan Conversion Procedure	4-6
4-8 Subrack Removal and Replacement Procedure.....	4-7
4-9 Filter Removal and Replacement Procedure	4-8
4-10 Circuit Breaker Panel Removal and Replacement Procedure	4-9
5-1 System Specifications.....	5-1

List of Figures

1-1 System Block Diagram	1-2
1-2 PAF System Model	1-2
1-3 Subrack.....	1-3
1-4 MCPA	1-3
1-5 Filter (if used).....	1-3
1-6 Circuit Breaker Panel.....	1-4
2-1 Subrack Interface Panel Connectors	2-1
2-2 Subrack Rear +27 VDC Connector Block.....	2-1
2-3 MCPA Controls and Indicators	2-3
2-4 Filter Front Connections	2-4
2-5 Filter Front Plate Indicators.....	2-5
2-6 Circuit Breaker Panel Front and Top View	2-6
3-1 Frame Installation	3-3
3-2 Power Connections.....	3-4
3-3 Return Bus connection	3-4
3-4 Frame to Halo Ground Connection Example.....	3-5
3-5 MCPA Front Panel Features.....	3-6
4-1 MCPA Removal and Replacement	4-3
4-2 Inside Mount Cooling Fan Removal and Replacement	4-4
4-3 Rear Mount Cooling Fan Removal and Replacement	4-5
4-4 Fan Inside Mount to Rear Mount Conversion	4-6
4-5 Subrack Removal and Replacement	4-7
4-6 Filter Removal and Replacement	4-8
4-7 Breaker Panel Unit Removal and Replace	4-9

This page intentionally left blank

Chapter 1

Product Description

Introduction

This manual contains information and procedures for installation, operation, and maintenance of the PAF-19XX-EX-XXX Multi-Carrier Power Amplifier (MCPA) Indoor System. The manual is organized into chapters as follows.

- ❑ Chapter 1 - Product Description
- ❑ Chapter 2 - Controls and Indicators
- ❑ Chapter 3 - Installation
- ❑ Chapter 4 - Maintenance
- ❑ Chapter 5 - Specifications

Scope of Manual

This manual is intended for use by service technicians familiar with similar types of equipment. It contains service information required for the equipment described and is current as of the printing date. Changes which occur after the printing date may be incorporated by a complete manual revision or alternatively as additions.

Product Description

The PAF-19XX-EX-XXX system, shown in the Figure 1-1 block diagram, is an 1900 MHz, 4-way combined, frame-mounted BTS solution. The PAF system contains three MCPA subracks, each capable of containing up to four MCPAs, three filters, and one DC circuit breaker panel.

The MCPA subrack, shown in Figure 1-3, contains linear, feed-forward MCPAs that operate in the 1930 - 1990 MHz range. Each subrack is also equipped with automatic power control (APC), an ethernet connection, an RS-485/RS-232 connection, a filter I/O port, and two cooling fans. The subrack is installed on sliding rails so that it can be pulled forward to allow access to the rear of the subrack.

The MCPA, shown in Figure 1-4, is a 1900 MHz module that produces a typical output of 160 watts (52.0 dBm) before system losses, with an instantaneous bandwidth of 25 MHz.

The filter assembly, shown in Figure 1-5, if used, suppresses unwanted signals and non-linear components of the signal from the amplifiers.

The circuit breaker panel, shown in Figure 1-8, consists of two +27 VDC input buses (A and B), and a system circuit breaker panel. The panel receives +27 VDC from the BTS and then distributes circuit breaker protected DC power to the individual subracks.

Functional And Physical Specifications

PAF-19XX-EX-XXX system functional and physical specifications are listed in Chapter 5.

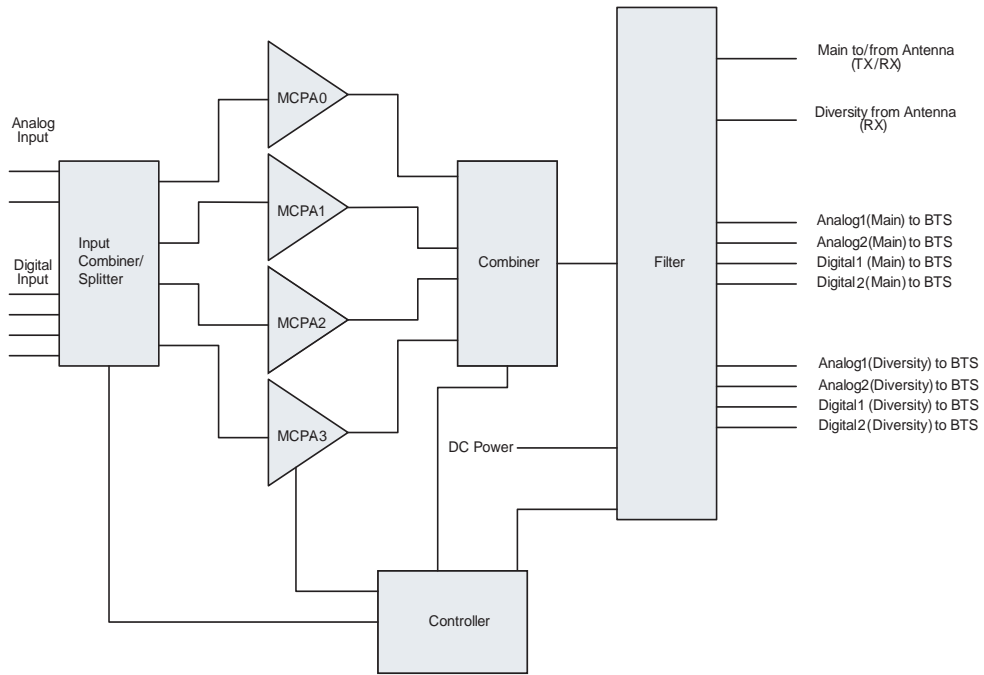

Figure 1-1 System Block Diagram

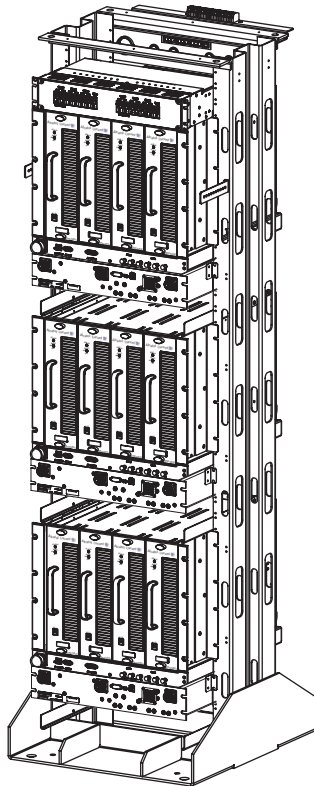

Figure 1-2 PAF System Model

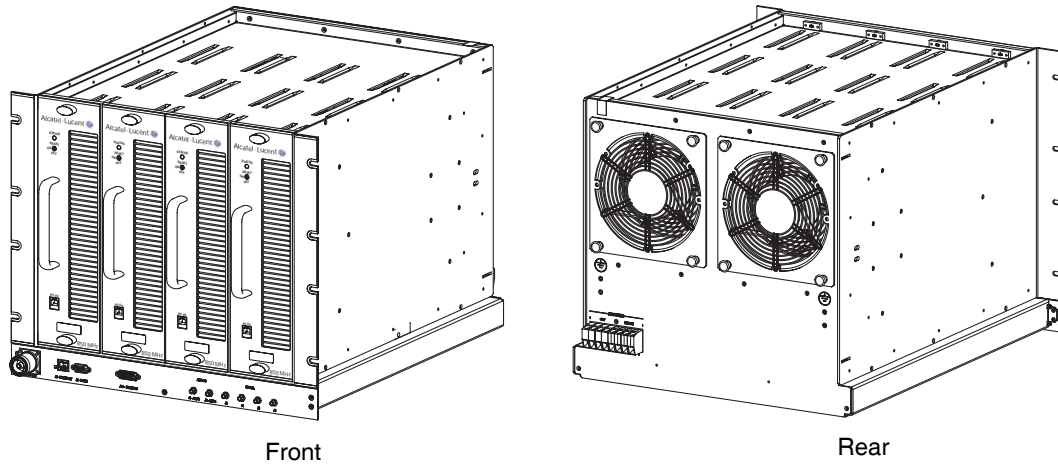

Figure 1-3 Subrack

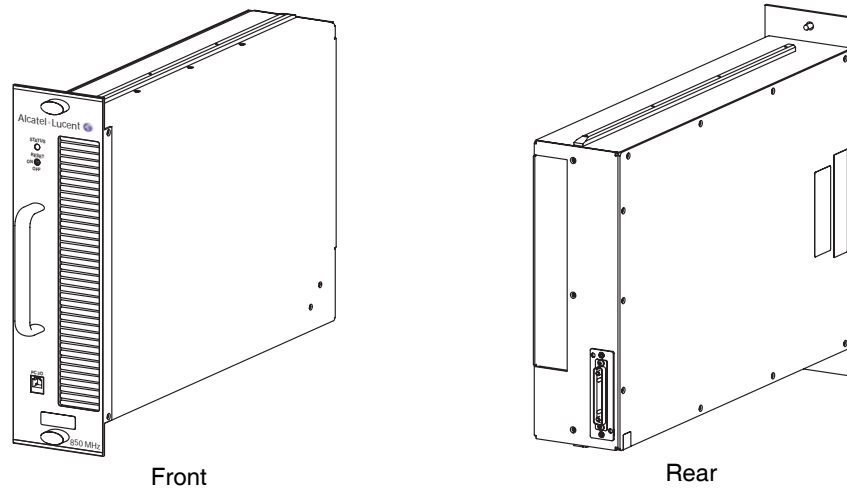

Figure 1-4 MCPA

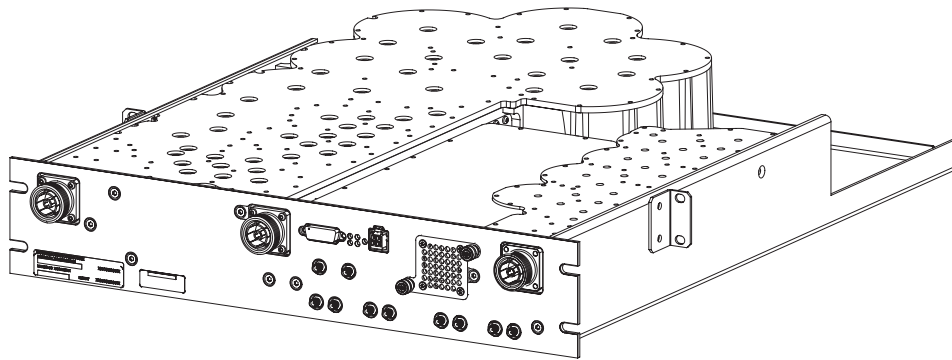

Figure 1-5 Filter (if used)

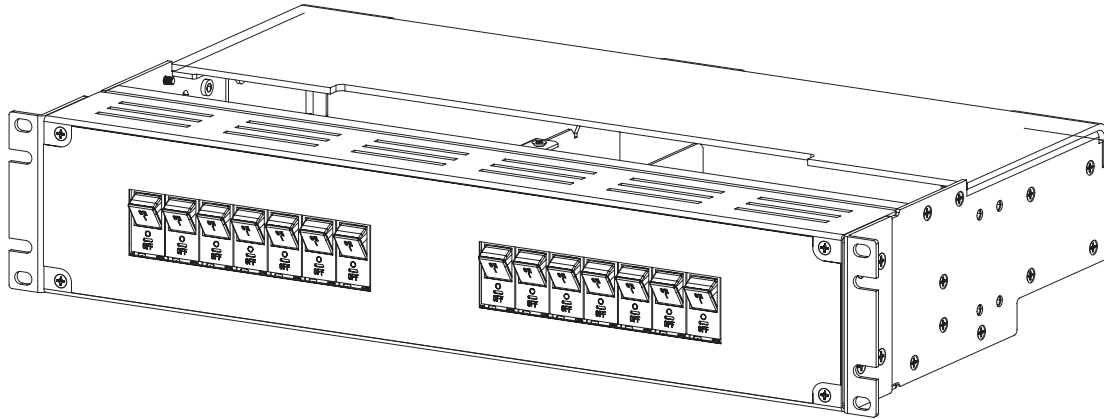

Figure 1-6 Circuit Breaker Panel

Chapter 2 Controls and Indicators

Introduction

This chapter contains descriptions of the PAF-19XX-EX-XXX subrack, MCPA, filter, and circuit breaker panel interface connections, controls and indicators.

Subrack

The location of the subrack interface controls, connectors, and indicator are shown in Figures 2-1 and 2-2 and feature descriptions are listed in Table 2-1.

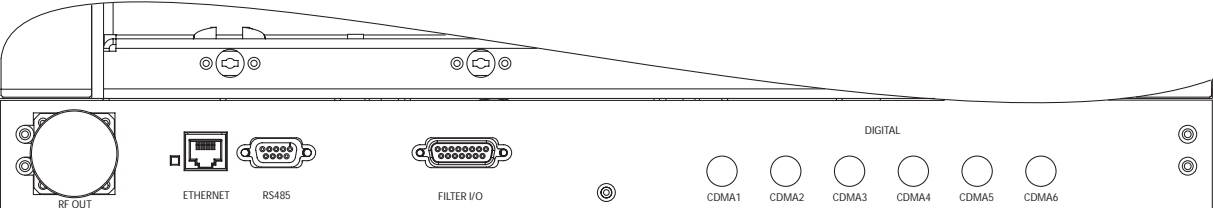

Figure 2-1 Subrack Interface Panel Connectors

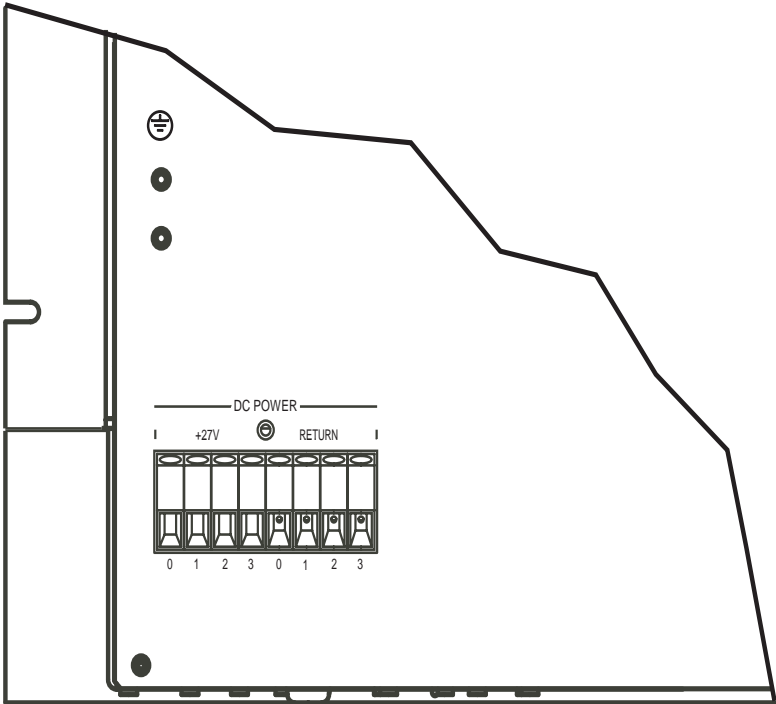

Figure 2-2 Subrack Rear +27 VDC Connector Block

Table 2-1 Subrack Faceplate Interface Connectors, and Indicators

Connectors	Description
RF	
DIGITAL (CDMA1 through CDMA6)	Six SMA input connectors
RF OUTPUT	7/16 DIN connector, composite transmit signal output.
Status	
ETHERNET	RJ-45 connector used for host alarm reporting, Pin layout is listed in Table 2-2
RS-232/RS-485	DB-9 connector used for host alarm reporting. Pin Layout is listed in Table 2-3
Filter	
Filter I/O	DB-15 connector to provide control and communication to filter (if used)
DC Power	
+27 VDC Connector Block (Rear of Subrack)	Provide connections for +27 VDC circuit breaker protected power from breaker panel and frame ground bus return connections.

Ethernet Connector Pinout

The Ethernet port is used for communication with a personal computer (PC) or with a base station. The pin layout for the Ethernet interface is listed in Table 2-2.

Table 2-2 Ethernet Connector Pinout

Pin	Description
1	Transmit Data (TX) +
2	Transmit Data (TX) -
3	Receive Data (RX) +
4	NC
5	NC
6	Receive Data (RX) -
7	NC
8	NC

RS-485 Interface

This RS-485 connector is used for serial communication and as an interface to the system for delivery of alarms. Grounding pin 8 disables RS-485 communication. Table 2-3 lists the pin descriptions.

Table 2-3 RS-485 Pinout

Pin	Description
1	RS-485 RX+
2	N/C
3	N/C
4	RS-485 RX-
5	Ground
6	RS-485 TX-
7	RS-485 TX+
8	Select = 1 (Not grounded)
9	Ground

Filter I/O (if used)

This port is used for communication with the filter tray associated with the subrack.

MCPA

The controls and indicators for the MCPA consist of an OFF/ON/RESET switch and tri-color LED status indicator as shown in Figure 2-3 with detailed functions listed in Table 2-2.

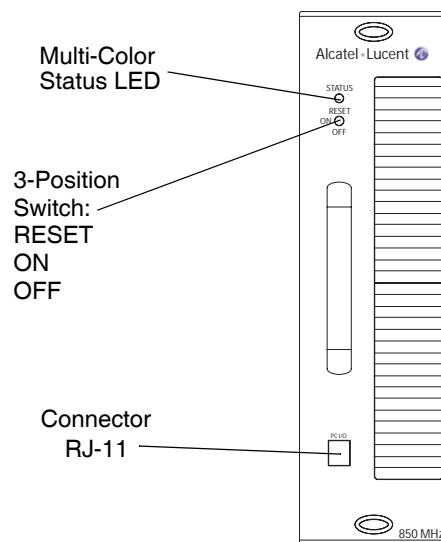

Figure 2-3 MCPA Controls and Indicators

Table 2-4 MCPA Indicators and Controls

Control/Indicator	Description	
STATUS (Multi-colored LED Indicator)	LED Color	MCPA Status.
	Green (solid)	RF enabled, OFF/ON/RESET switch set to ON (middle position).
	Green (blinking)	Standby.
	Yellow (solid)	Major Alarm
	Yellow (blinking)	APC Activated
	Red (solid)	Critical Alarm, MCPA disabled.
	Red (blinking)	Over Temperature Alarm
	Red/Yellow (blinking together)	High Reverse Output Power 1 minute validation period
Red/Yellow (alternating)	Critical Alarm during remote firmware download or checksum failure	
Toggle Switch positions: RESET (Up) ON (Middle) OFF (Down)	Resets MCPA. LED indicates boot mode, then turns solid green. Enables MCPA. LED indicates solid green. Disables MCPA. LED Indicates solid red.	
RJ-11	RS-232 PC Interface for factory use only.	

Filter (if used)

Figure 2-4 shows the front plate of the filter. Table 2-3 lists the descriptions of the connectors. Figure 2-5 shows the five indicators on the filter front panel. The LED will display a green light during normal operation and red light if the indicated stage has suffered a catastrophic failure.

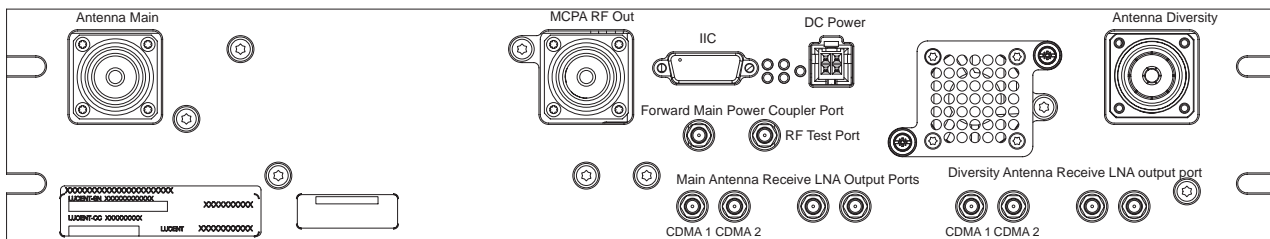

Figure 2-4 Filter Front Connections

Table 2-5 Filter Connector Descriptions

Connector/Cable	Description
Antenna Connections	
Antenna Main	7/16 connector - Dx0 (bi-directional) antenna port
Antenna Diversity	7/16 connector - Dx1 (simplex RX) antenna port
Subrack Connection	
MCPA RF Out	7/16 connector - connects subrack to receive output signal
IIC	DB-15 connector for communication between filter and subrack
BTS Connections	
CDMA 1	Dx0 Receive LNA Output Port CDMA
CDMA 2	Dx0 Receive LNA Output Port CDMA
	Dx0 Receive LNA Input Port AMPS
	Dx0 Receive LNA Output Port AMPS
CDMA 1	Dx1 Receive LNA Output Port CDMA
CDMA 2	Dx1 Receive LNA Output Port CDMA
	Dx1 Receive LNA Output Port AMPS
	Dx1 Receive LNA Output Port AMPS
Test Port Connections	
RF Test Port	SMA connector - Switched Coupler Port (4-way)
Forward Main Coupler Port	SMA connector - Dx0 Forward Power Coupler Port
Power Connection	
Power	Power connection

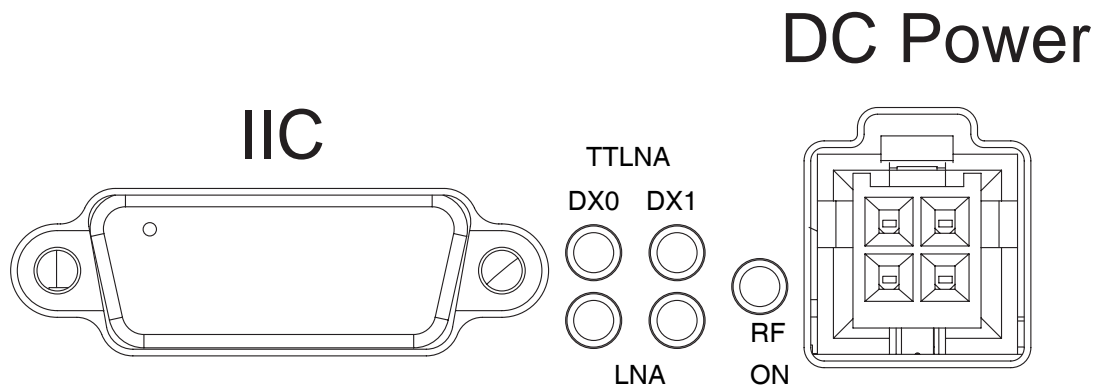

Figure 2-5 Filter Front Plate Indicators

Circuit Breaker Panel

Figure 2-6 shows the switches on the front of the breaker panel and the cable connections on the rear. Chapter 3 discusses power cable connection.

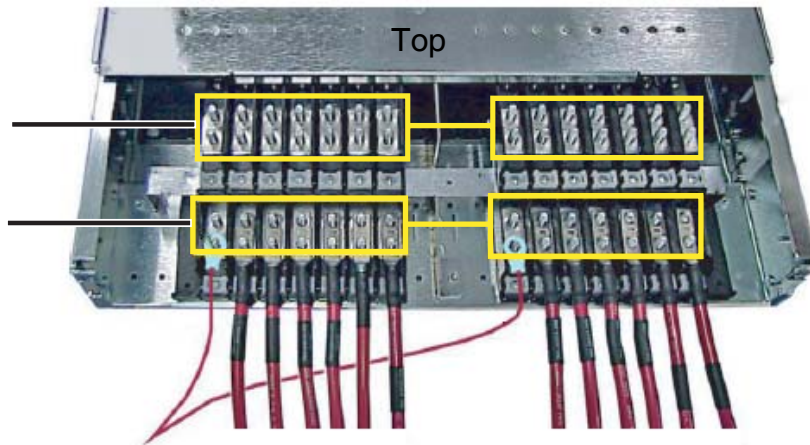
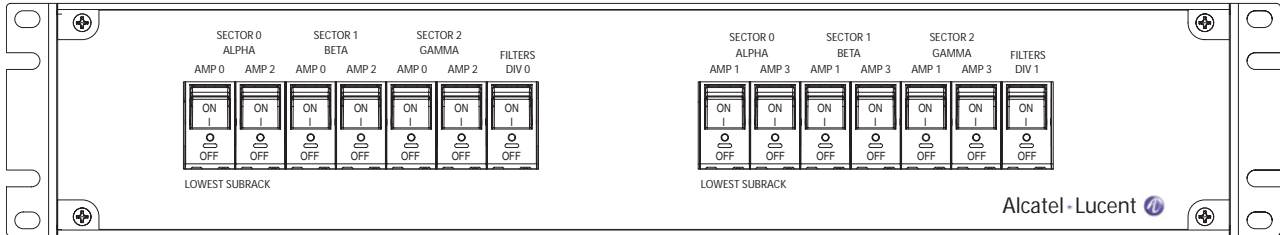

Figure 2-6 Circuit Breaker Panel Front and Top View

Chapter 3 Installation

Introduction

This chapter contains unpacking, inspection, installation instructions, and recommendations for installing the PAF-19XX-EX-XXX MCPA Indoor System.

Site Survey

Powerwave recommends that a site survey be performed prior to equipment ordering or installation. Performing a detailed site survey reduces or eliminates installation and turn-up delays. Pay particular attention to AC or DC power availability, cooling needs, floor space, and RF/DC cabling/breaker requirements. See Chapter 5 for system dimensions and weights.

Space Requirements

The PAF system requires the following floor space for clearance (W x D x H): 28.5 inches (724 mm) x 78.2 inches (1986 mm) x 38.5 inches (978 mm). To properly service the system, an additional 48 inches (1220 mm) is required in the front of the unit. To permit proper airflow, allow a minimum of 8.27 inches (210 mm) behind the PAF.

Unpacking and Inspection

This equipment has been operated, tested and calibrated at the factory. Carefully open the containers and remove the equipment. Retain all packing material that can be reassembled in the event that the unit must be returned to the factory. Please perform the following steps:

- ❑ Visually inspect equipment for damage that may have occurred during shipment. If possible, in the presence of the delivery person.
- ❑ Check for evidence of water damage, bent or warped chassis, loose screws or nuts, or extraneous packing material in connectors.

If the equipment is damaged, file a claim with the carrier once the extent of any damage is assessed.

If the equipment must be returned to the factory, contact the factory for a Return Material Authorization (RMA) as described in Chapter 4.

Electrical Service Recommendations

Proper AC line conditioning and surge suppression is necessary on the primary AC input to the +27 VDC power source. Powerwave recommends that all electrical service be installed in accordance with the National Electrical Code (NEC) and any applicable state or local codes.

Table 3-1 lists a sample of DC cable ratings.

Table 3-1 Sample of DC Cable Ratings

AWG or MCM	mm ²	Copper					
		3 Conductor In Raceway			Single Conductor In Free Air		
		75°C	90°C	110°C	75°C	90°C	110°C
10	5		40	45	50	55	65
8	8	57	55	60	70	75	85
6	13	76	70	80	95	100	120
4	21	101	95	105	125	135	160
2	34	135	125	135	170	185	210
1	42	158	145	160	195	215	245
0	53	183	165	190	230	250	285
00	67	212	195		265	300	
000	85	245	225		310	350	
0000	107	287	260		360	405	
MCM250	127	320	290		405	455	
MCM300	152	359	320		445	505	

Based on ambient temperature of 30°C (86°F) 100% Load Factor
 Source: Industrial Electric Wire & Cable Inc., Technical Guide Vol. 4M 11/99, Table III Suggested Ampacities - All Types of Insulations; Based on National Electric Code

Cooling Requirements

Each MCPA at full power generates the BTUs per hour listed in Table 3-3. A 1-ton air conditioner offsets 12,000 BTUs of heat. The MCPA operates within the temperature environment specified in Chapter 5.

Fan speed is dependent on MCPA operating temperature. The fans remain off until the MCPAs exceed +43°C base plate temperature. Once enabled, the fan remains on until all MCPA base plate temperatures are below +41°C.

Installation Instructions

Install the PAF frame, DC and RF connections, alarms, and MCPAs as described in the following paragraphs.

PAF

To install the PAF frame, perform the instructions in Table 3-4.



CAUTION: The PAF frame, as factory shipped, weighs approximately 250 lbs (113 kg) to 428 lbs (194 kg) depending on configuration (MCPAs not included). During unpacking and installation, be careful with the semi-rigid cables. Protect the cables from damage by avoiding contact with doorways or other equipment. Do not use the cables as handles for moving the components or the frame.

NOTE Reuse shipping pallet washers to secure PAF to installation site floor.

Table 3-2 PAF Frame Installation Procedure

Step	Action
1.	Set PAF frame in planned location
2.	Mark floor drill holes on floor where lag bolts will be installed. Move frame to side. Refer to lag bolt manufacturer's instructions for hole depth and diameter
3.	Move frame back over drilled holes
4.	Use a level to ensure frame is not leaning. Insert shims between frame base and floor to level frame. Shims should wrap around lag bolts as shown in Figure 3-2
5.	Secure frame in place with red eye lag bolts and appropriate washers

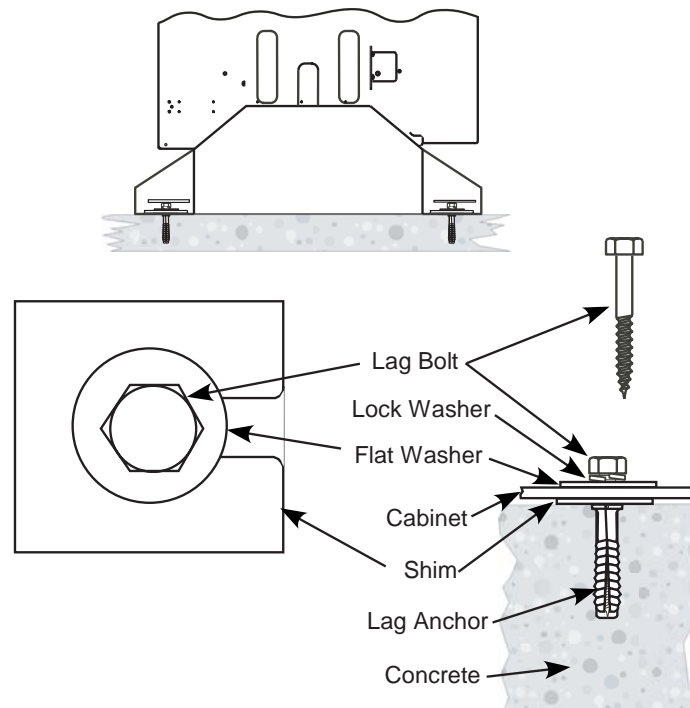

Figure 3-1 Frame Installation

Seismic Brace (Optional)

The PAF system meets GR-63-CORE, Section 4.4.1, Zone 4 compliance. If additional bracing is required, Powerwave offers an optional seismic brace kit for those circumstances. Please contact a Powerwave sales representative for additional information and assistance.

DC Connections

Connect and verify DC power cables between the BTS power plant and the PAF system circuit breaker panel and PAF return bus located at the top of the PAF as instructed in Table 3-5. Required power is +27 VDC, and each power input is directly connected through the circuit breaker in the front of the panel to the power output directly below it in the panel.



WARNING: Turn off external DC power before connecting DC power cables.

Table 3-3 DC Power Installation Procedure

Step	Action
1.	Remove circuit breaker panel top protective cover
2.	Connect fourteen individual red power cables, one to each input on the upper row of connections. (designated Row A Figure 3-2)
3.	Attach opposite ends of red MCM 250 powr cables to power plant's main DC bus bar after main shunt.
4.	Insert fourteen individual black power cables into front of yellow and green ground connections as shown in Figure 3-3 and tighten screws
5.	Attach opposite ends of black power cables to power plant's main DC return bus bar
6.	Connect PAF frame to halo grounding system at frame top (four locations) using green 6 AWG cable as shown in Figure 3-4
7.	Reinstall circuit breaker panel top protective cover.
8.	Affix supplied ground sticker directly beneath one utilized frame grounding points shown in Figure 3-4

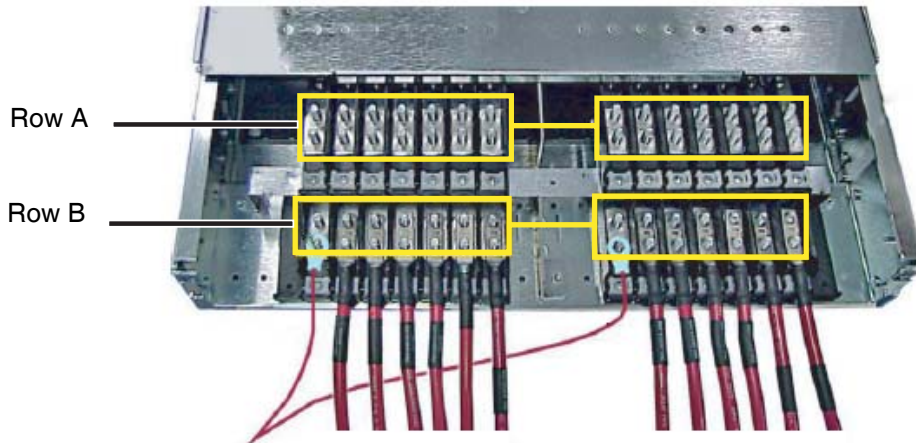

Figure 3-2 Power Connections

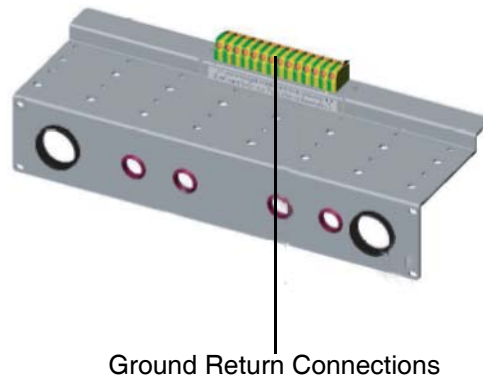

Figure 3-3 Return Bus connection

NOTE DO NOT remove metallic tape at frame top when connecting to Halo ground system. Removing tape voids PAF frame warranty.

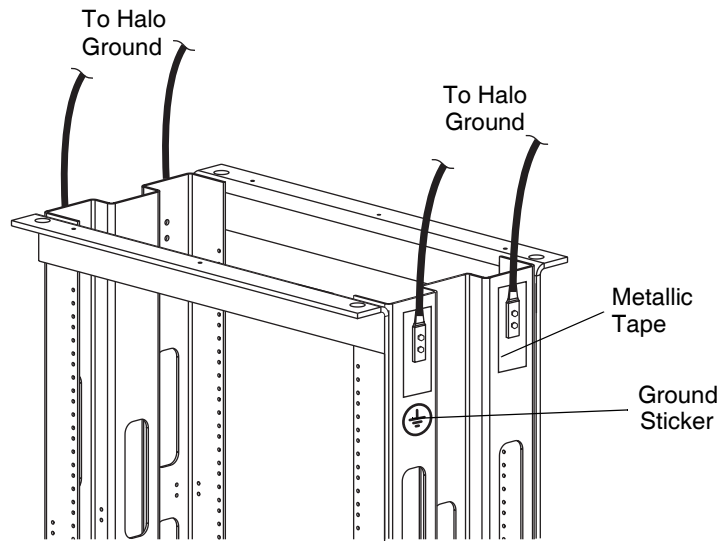

Figure 3-4 Frame to Halo Ground Connection Example

RS-485 Alarm Interface

The RS-485 alarm interface provides the BTS controller with system status via a 1 byte protocol. The baud rate is fixed at 15.6 K. Table 3-6 lists the available alarm states.

Table 3-4 RS-485 Alarm States

AlarmState	Definition
No Alarm	
Minor Alarm	Any or all fans fail
Major Alarm	Any one MCPA module disabled
Critical	All MCPA modules disabled

MCPA

Install the MCPAs as instructed in Table 3-7.



CAUTION: Slowly insert MCPA into subrack. Forcing MCPA into subrack may cause pins on the MCPA D-sub connector to become recessed or broken.

Table 3-5 MCPA Installation Procedure

Step	Action
1.	Inspect MCPA 21-pin connector. Verify all pins are straight, no pins are recessed, and alignment shield is not bent
2.	Set MCPA power OFF/ON/RESET switch to OFF
3.	Rotate MCPA quarter-turn fasteners counter-clockwise to unlock position shown in Figure 3-8
4.	Install MCPA(s) into subrack. To secure each MCPA, rotate quarter-turn fasteners clockwise to lock position as shown in Figure 3-8

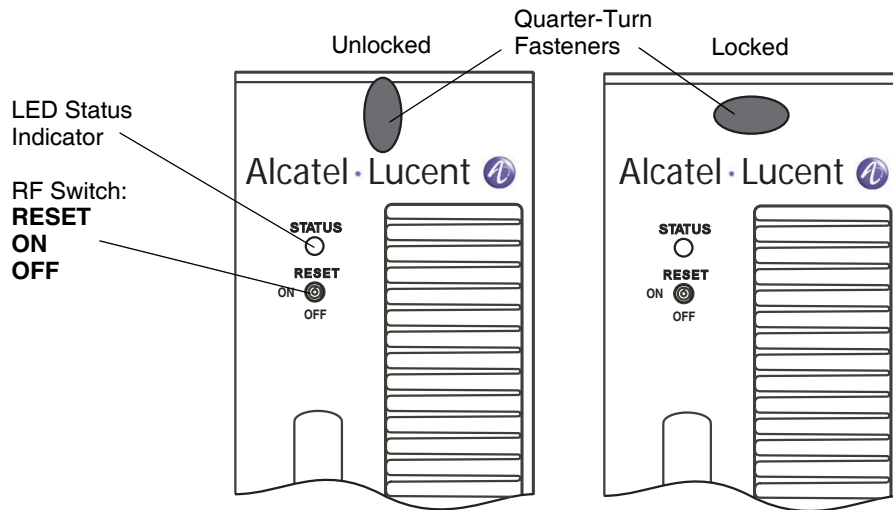

Figure 3-5 MCPA Front Panel Features

Initial Start-Up and Power Setting Procedures

The following paragraphs provide initial startup, and power setting procedures.

Initial Start Up

To complete initial startup, perform the instructions listed in Table 3-8.



CAUTION: Excessive input power may damage MCPA. Before applying power, ensure MCPA inputs and outputs are properly terminated at 50 ohms. Do not operate MCPA without a load attached. Refer to Chapter 5 for input power requirements.

Table 3-6 Initial Startup Procedure

Step	Action
1.	Verify all input and output cables are properly connected
2.	Turn on +27 VDC supply to MCPA
3.	Set all MCPA front panel OFF/ON/RESET switches to ON (middle) position
4.	Allow MCPAs to warm up for at least two minutes before taking power readings