

## Field Replaceable Parts and Modules

The MCPAs, rectifier modules, Control Module, Modem, RF conditioning unit, door fan assemblies, and power system fuses can be replaced in the field on site by a qualified technician with experience maintaining RF power amplifiers and similar equipment.

Opening the front or rear doors, or both as appropriate, is required to perform the following maintenance operations. Door latches are 1/4 turn and require a 10 mm hex socket wrench or nut driver to open.

Table 4-3 lists the model numbers and descriptions for ordering individual field replaceable system components.

Table 4-3 Field Replaceable System Components

Model Number	Manual Number	Description	Quantity per System
OS-1933-E0-000	N/A	OS System w/o MCPAs, Rectifier and RFCU	1
G3L-1929-160-001	044-05305	Multi-Carrier Power Amplifier	1 to 3
1001308	N/A	Rectifier Module	1 to 4
800-20160-002	N/A	Fan Assembly, 300 cfm, Rear Door	1
800-24963-001	N/A	Fan Assembly, 300 cfm, Front Door	1
INST-OS-1933-E0-000	N/A	Controller	1
100-24370-001	N/A	Integrated RF Conditioning Unit (RFCU)	1
100-10544-001	N/A	Air Filter	2
100-07892-002	N/A	Blank Panel MCPA	As Required
100-24232-001	N/A	Blank Panel, RFCU	As Required
1004415	N/A	Fuse, MIDI Time Lag, Automotive Bolt-down, 60A, 32 V, (Littelfuse)	As required
1004416	N/A	Fuse, Fast Acting, Cartridge, 15A, 250V (Littelfuse)	As required

### MCPA Removal and Replacement

Perform the instructions in Table 4-4 to remove and replace the MCPA shown in Figure 4-1 MCPA Removal and Replacement.



**CAUTION:** When removing the MCPA from the subrack, support the rear of the MCPA to prevent a sudden drop when the guide rail disengages from the track. This could damage the rear multi-pin connector. The MCPA weights approximately 20 lbs. (9.1 kg).  
 If an MCPA module is removed, another MCPA or blank panel must be installed in its place to provide adequate cooling.  
 Always disable the MCPA of a sector prior to the removal of a MCPA or RFCU of that sector.

Table 4-4 MCPA Removal and Replacement Procedures

Step	Action
1	Set OFF/ON/RESET switch on front panel of MCPA down to OFF.
2	Rotate latches securing MCPA to subrack counterclockwise.
3	With steady even pressure, use handle on front of MCPA to slide MCPA out of subrack.
4	Replace MCPA by carefully sliding MCPA into empty subrack slot. Secure MCPA by turning two latches clockwise.

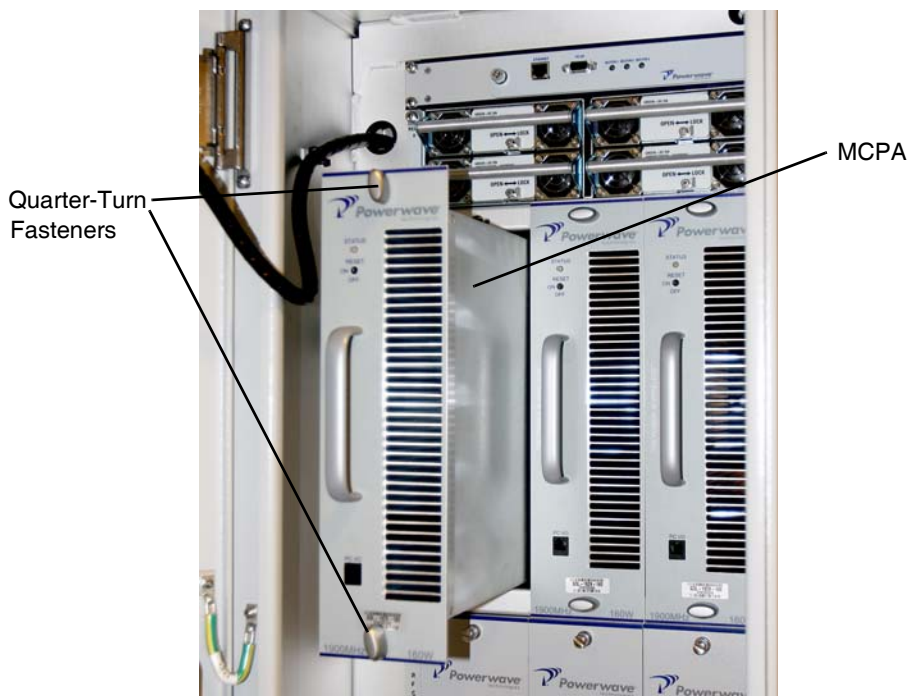

Figure 4-1 MCPA Removal

### Rectifier Module Removal and Replacement

Perform the instructions in Table 4-5 to remove and replace the rectifier module shown in Figure 4-2



**CAUTION:** The rectifier module weighs approximately 5 lbs. (2.3 kg). When removing the rectifier module from the subrack, support it at the rear when the guide rail disengages from the track to avoid dropping the module. Dropping the rectifier module could damage the rear multi-pin connector.

Table 4-5 Controller Module Removal and Replacement Procedures

Step	Action
1	Using a #2 Phillips screwdriver, loosen the Phillips fastener securing the latch.
2	Slide and hold latch to left
3	Use handle to carefully pull rectifier module out of cabinet
4	Replace rectifier by carefully sliding rectifier into empty slot until rectifier is secured

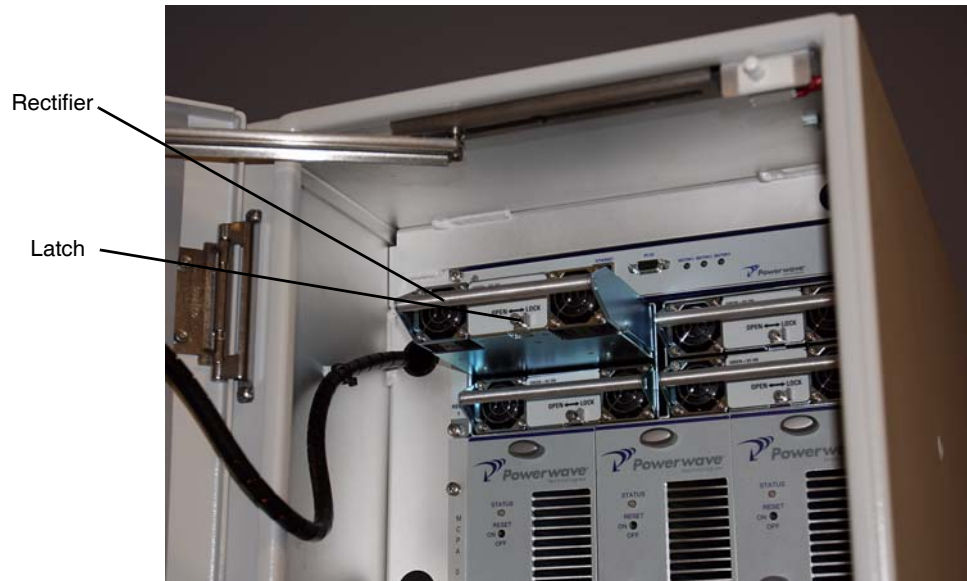

Figure 4-2 Rectifier Removal and Replacement

## Controller Module Removal and Replacement

Perform the instructions in Table 4-6 to remove and replace the Controller Module shown in Figure 4-3.

Table 4-6 Controller Module Removal and Replacement Procedures

Step	Action
1	Remove external AC power from OS enclosure
2	With enclosure front access door open, rotate two thumbscrews counterclockwise to release Controller Module
3	Using two thumbscrews, pull Controller Module out of enclosure
4	Install new Controller Module in reverse order

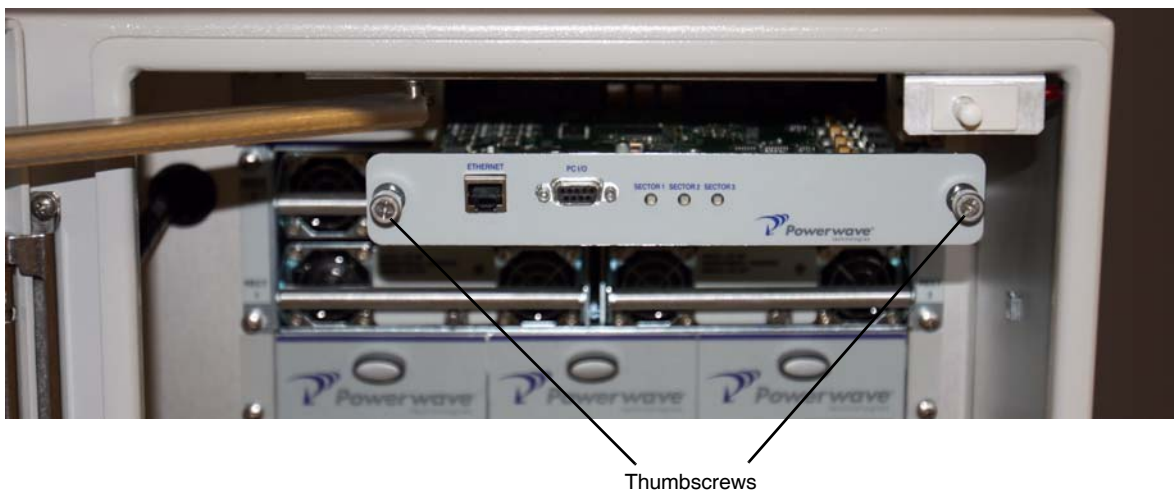

Figure 4-3 Controller Module Removal and Replacement

### RF Conditioning Unit (RFCU) Removal and Replacement

Perform the steps listed in Table 4-7 to remove and replace the RF conditioning unit shown in Figure 4-4. The RFCU unit contains unique calibration tables. The OS system will upload the tables to the Controller automatically upon insertion.



**CAUTION:** The RFCU weighs approximately 40 lbs. (18.14 kg). When removing the RFCU Module from the subrack, support it at the rear when the guide rail disengages from the track to avoid dropping the module. Dropping the RFCU Module could damage the rear multi-pin connector.

Always disable the MCPA of a sector prior to the removal of a MCPA or RFCU of that sector.

Table 4-7 RF Conditioning Unit (RFCU) Removal and Replacement

Step	Action
1	Disable the MCPAs in the affected sectors.
2	Disconnect external cables to RFCU interface in the affected sectors.
3	Using a slotted screwdriver with a 8mm (5/16 in) typical blade, loosen the top and bottom fasteners securing the RFCU to the OS system.
4	With steady pressure, use the handle on the front of the RFCU to slide the unit out of the OS system.
5	Replace RFCU in reverse order

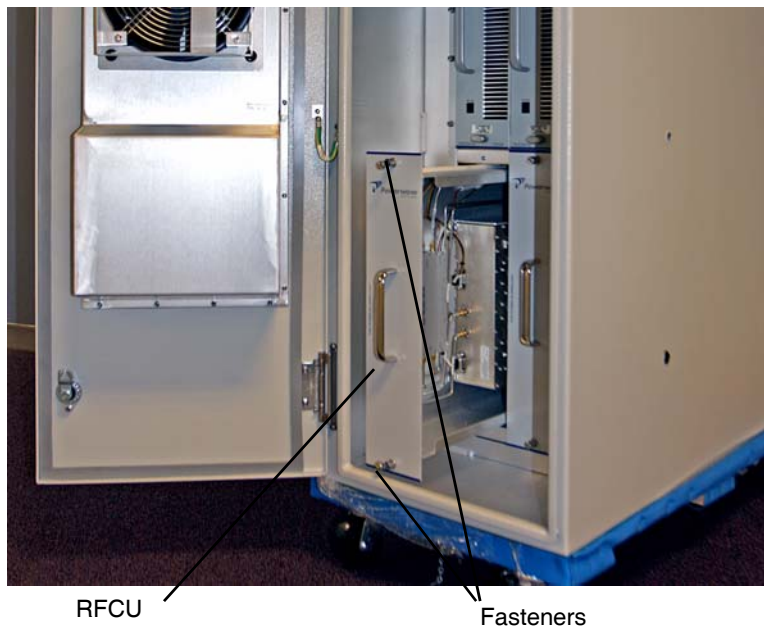

Figure 4-4 RF Conditioning Unit Removal and Replacement

## Fan Assembly Removal and Replacement

Perform the instructions in Table 4-8 to remove and replace the fan assembly shown in Figure 4-5.

Table 4-8 Fan Assembly Removal and Replacement Procedures

Step	Action
1	Open appropriate cabinet door.
2	Disconnect fan connector.
3	Pull out on four fasteners that secure fan assembly, then remove fan assembly.
4	Align fan assembly and push in fasteners to reattach fan assembly, then reconnect fan connector.



**CAUTION:** Ensure the fan assembly is replaced by the correct type. Front fans and rear fans are assembled different per air flow.

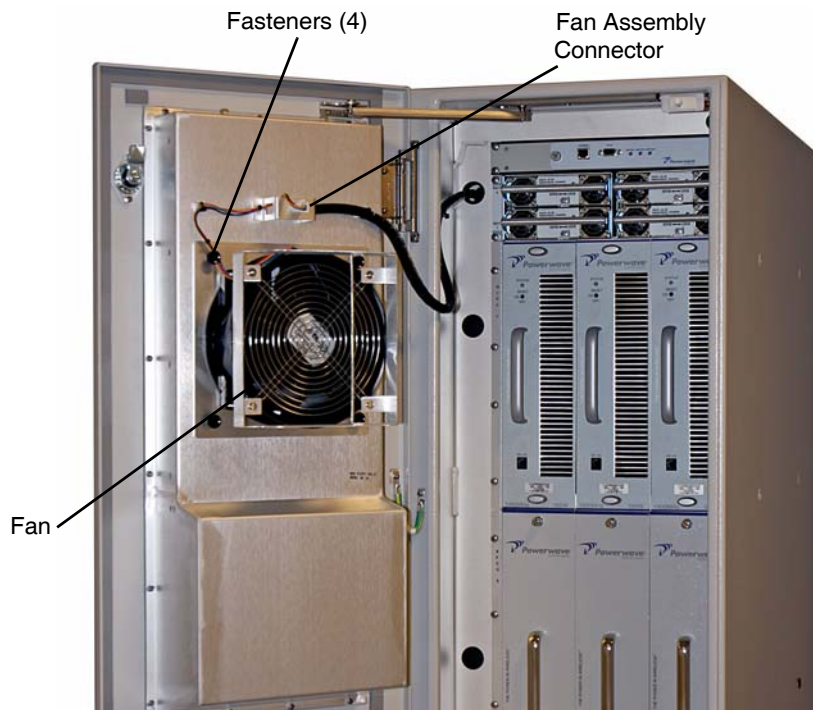

Figure 4-5 Fan Assembly Removal and Replacement

### Air Filter Cleaning

Perform the instructions in Table 4-9 to clean the air filters shown in Figure 4-6.

Table 4-9 Air Filter Cleaning Procedures

Step	Action
1	Open front door of OS. Fans power off automatically when door is opened
2	Pull up to remove air filter from OS
3	Clean air filter using water spray or compressed air. Allow filter to dry if using water spray
4	Slide filter back into empty slot and secure front door

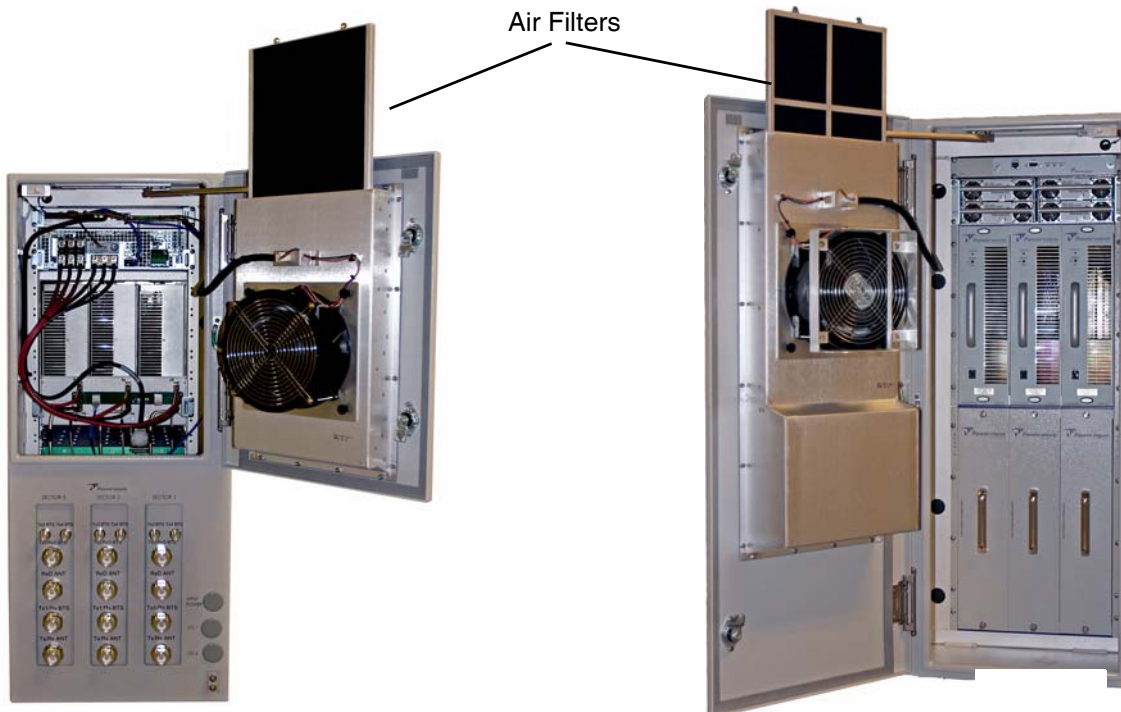

Figure 4-6 Air Filter Removal, Cleaning, and Replacement

## Power System Fuse Removal and Replacement

The fuses for the power system are located on the back panel as shown in Figure 4-7. Perform the instructions in Table 4-10 to remove and replace the power system 60 amp DC fuses. Perform the instructions in Table 4-11 to remove and replace the power system 15 amp fuse.

Table 4-10 60-Amp Fuse Removal and Replacement Procedures

Step	Action
1	Remove AC to booster via external AC circuit breaker.
2	Open rear door of OS. Verify AC is removed.
3	Pull up to snap open fuse protective cover.
4	Remove screws securing top of appropriate fuse. Remove hex nut and disconnect cable at bottom of fuse. Verify replacement fuse has correct rating.
5	Replace screws to secure fuse. Push up to close protective cover.
6	Close rear door of OS

Table 4-11 15-Amp Fuse Removal and Replacement Procedures

Step	Action
1	Open rear door of OS.
2	Remove screw-in fuse cap and remove fuse. Verify replacement fuse has correct rating.
3	Replace fuse and replace fuse cap.
4	Close rear door of OS.

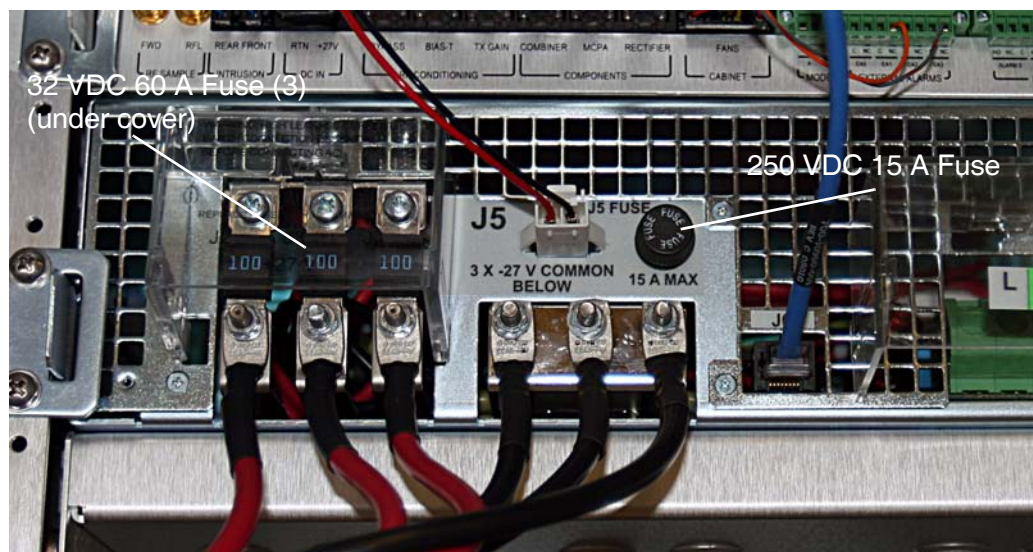

Figure 4-7 Fuse removal and replacement



This page intentionally left blank

# Chapter 5

## Specifications and Drawings

### Introduction

The performance and physical specifications for the OS-1933-E0-003 Outdoor Multi-Carrier Power Amplifier (MCPA) System are listed in Table 5-1. Outdoor System (OS) dimensions and installation examples are shown in Figures 5-1 through 5-4.

Table 5-1 Outdoor System Specifications

Electrical	Specifications/Features
Tx Frequency Ranges	1930 MHz to 1990 MHz
Rx Frequency Range	1850 MHz to 1910 MHz
Output Power (typical)	115W (50.97 dBm) per sector 375W total per site
Instantaneous Bandwidth	60 MHz
Air Interface	3GPP TS45.005, 25.141
Frequency Separation	1.25 MHz minimum, 40 MHz maximum
Input Power from BTS	+47 dBm maximum per port
Intermodulation	-62 dBc
Bypass Insertion Loss	<1.0 dB, TX and RX
Receive Band Insertion Loss	Adjustable RX gain from G < 0dB to G > 12dB
TX Rejection in RX Band	-115dBm/100kHz
Impedance, All Ports	50 ohms, 14 dB RL
Alarms	Form-C, wireless modem (optional)
RF Bypass (Alarm and Power Outage)	Included
TX Gain Range (typical)	Adjustable: Min < 0, Max >17dB TX1 - Ant Min < 0, Max >17dB TX2 - Ant Min < 0, Max >17.8dB TX3 - Ant Min < 0, Max >17.8dB TX4 - Ant
Gain Flatness	1.5 dB, peak to peak maximum
Lightning Protection	20 kA EIC 61000-4-5 8/20 US waveform
Operating Voltage	AC: 180 to 264 VAC (220 VAC typical), single phase, 47 to 63 Hz (60 Hz typical)

Table 5-1 Outdoor System Specifications (Continued)

<b>Mechanical</b>	<b>Specifications/Features</b>
Input RF Connector	7/16 DIN
Output RF Connector	7/16 DIN
AC Power Connection	Screw terminal barrier block (5-20 AWG)
Housing	IP55 IP rating
Dimensions	Refer to Figure 5-1 Outdoor System Dimensions
Weight populated	175 kg (386 lbs)
Minimum Clearances	<p>Front Door: 152.4 mm (6 in.) for airflow, 431.8 mm (17 in.) for opening door, 914.4 mm (36 in.) for installation and removal of modules</p> <p>Rear Door: 152.4 mm (6 in.) for airflow, 431.8 mm (17 in.) for opening door</p> <p>Hinge Side: 304.8 mm (12 in.) for 135 deg door opening (Preferred), 7.62 mm (3 in.) for 90 deg door opening</p> <p>Lock Side: 12.7 (0.5 in.)</p> <p>Bottom: 152.4 mm (6 in.)</p>
Seismic	Zone 4 (GR-63-CORE, Section 4.4.1, Issue 1)
<b>Environmental</b>	<b>Specifications/Features</b>
Environmental Application	Outdoor
Operating Temperature Range	-20 °C to +50 °C
Storage Temperature Range	-40 °C to +85 °C
Humidity	+5% - +100% RH @ +40°C
Cooling	DC fans
Acoustic Noise	<65 dBA (GR-487-CORE, Section 3.29, Issue 2)
Altitude	-60 to 4000 meters
Seismic	Zone 4 (GR-487-CORE, Section 3.29, Issue 2)
Transportation Shock	IEC 60068-2-29, 100 bumps per axis.
Transportation Bounce	IEC 60068-2-55 Test Ee, Method A: Bounce 1.1 to 1.2 g, 6 sides with 90° horizontal rotation ½ through each side. 180 minutes total test time. This test is applicable to non-palletized equipment only.
Transportation Vibration	GR-63 CORE, Section 4-4-4
Handling Drop (Packaged)	GR-63 CORE, Section 5.3.1
Unpackged Drop	GR-63 CORE, Section 5.3.2
Operational Vibration	2.0g over vib. freq. range of 5 to 200 Hz
Wind Speed	50 m/s

Table 5-2 Weights and Measures

Enclosure	Weights and Dimensions
Dimensions	Width: 406 mm (16 in.), Height: 996.95 mm (39.250 in.), Depth: 964.64 mm (38.0 in.)
Clearance dimensions	Width: 406 mm (16 in.) Height: 1016 mm (40 in.) from the bottom. Depth: 964.64 mm (38.0 in.)
Cabinet weight (shipping)	185 lbs. (84 kg) without MCPAs or modem
Cabinet weight (populated)	385 lbs (175 kg) maximum

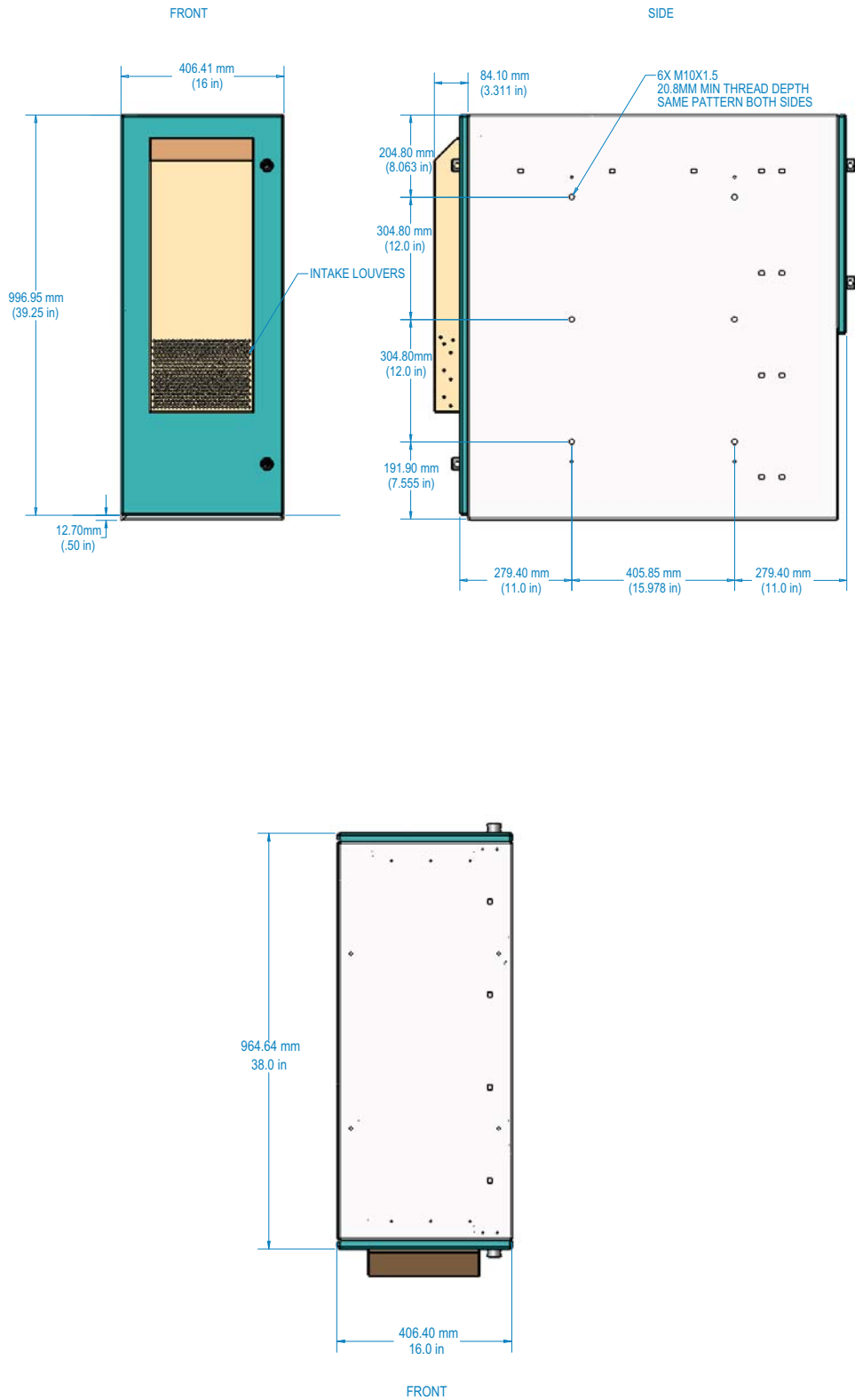

Figure 5-1 Outdoor System Dimensions

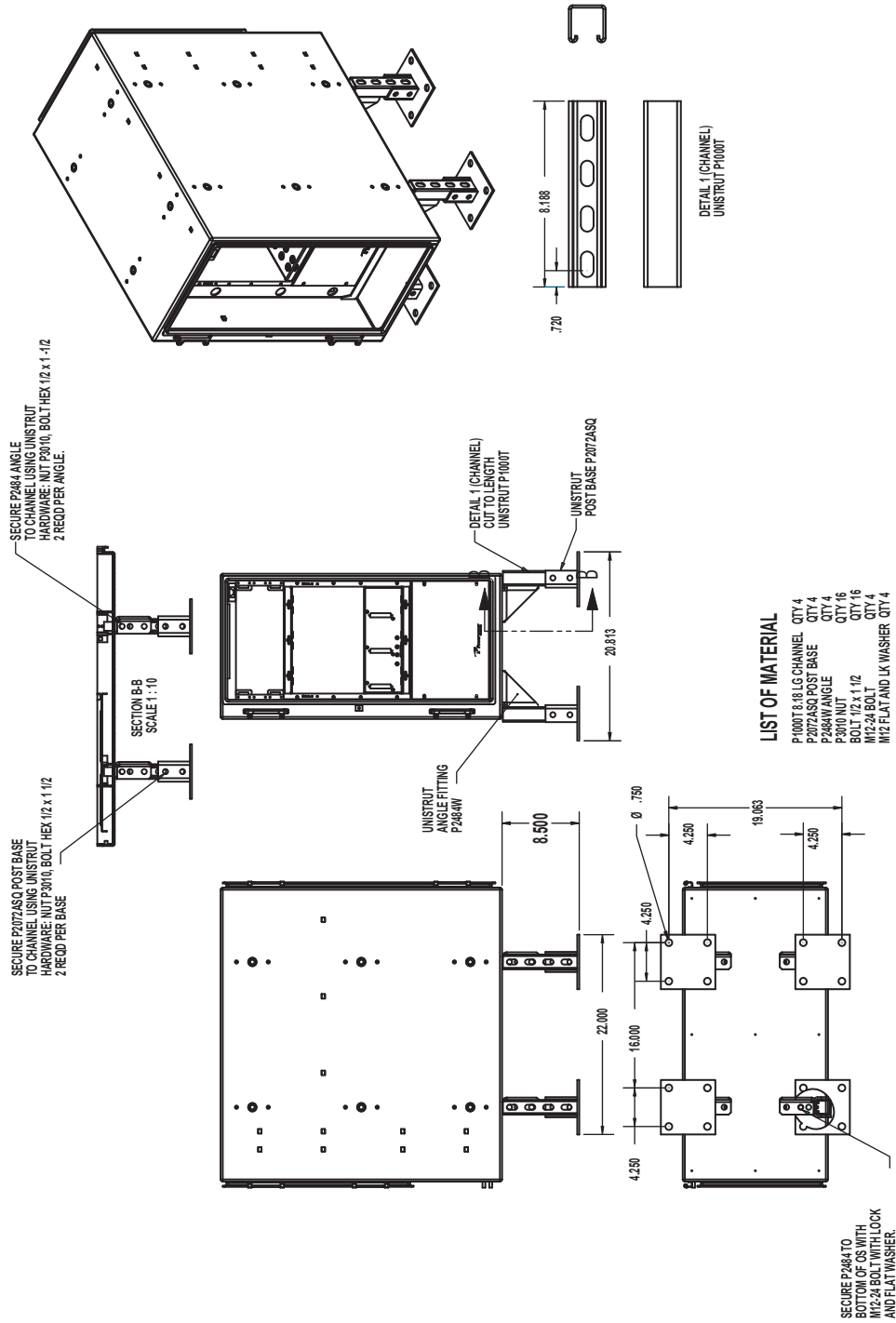

Figure 5-2 Installation Example One

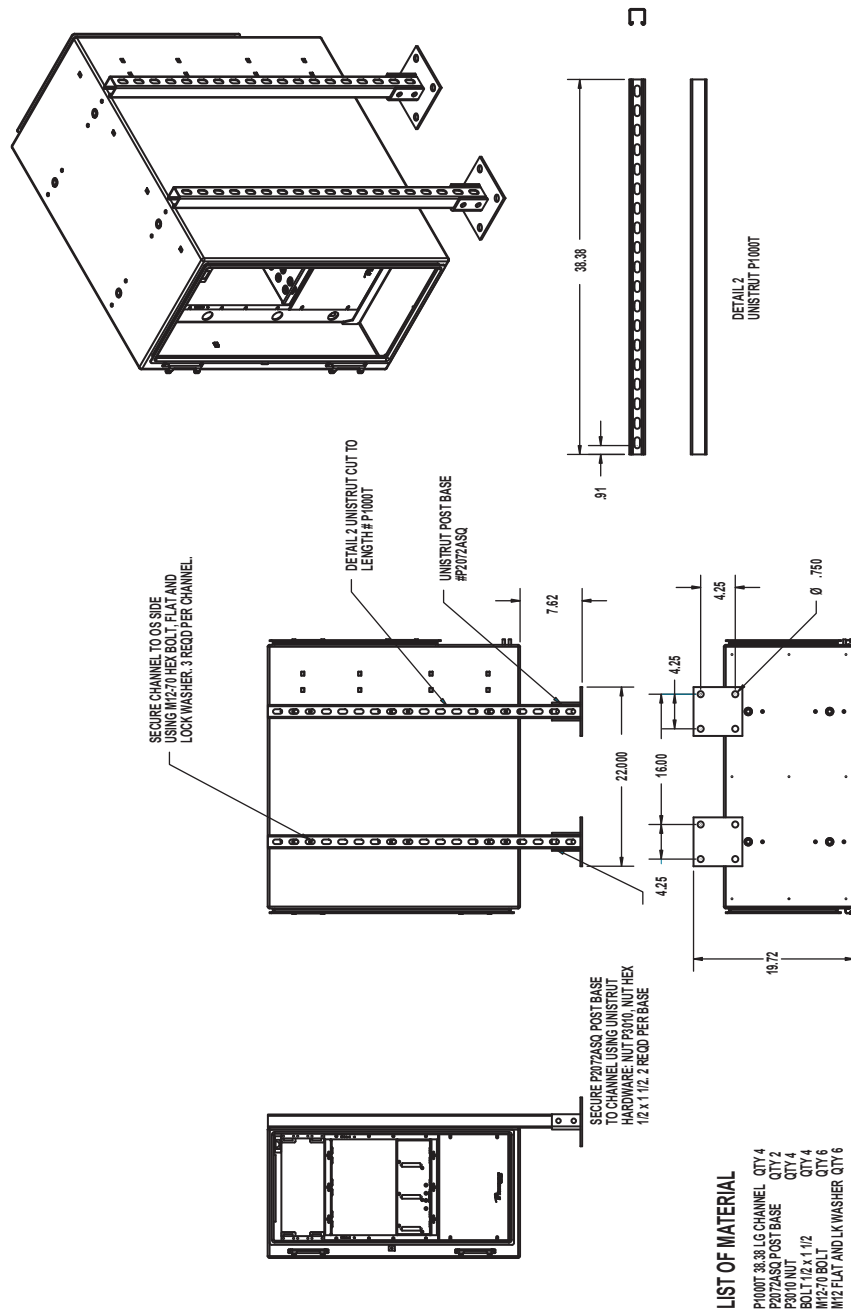

Figure 5-3 Installation Example Two

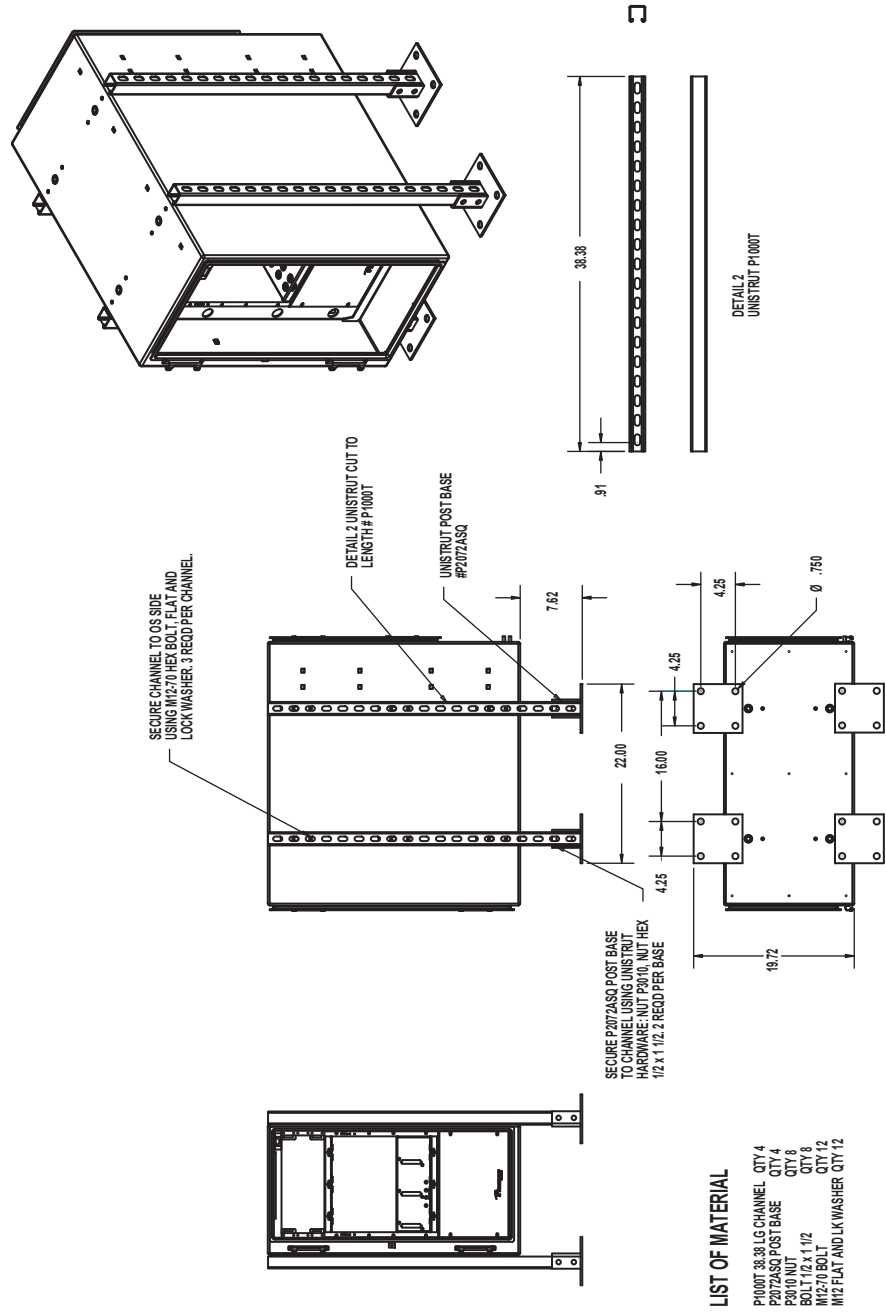

Figure 5-4 Installation Example Three