



Data Transmission Unit

Addendum B Installation Instructions

DTU-G-010-1/B

For Part 23 P&W Engine Services, Inc.

Generation III Monitors

Proprietary Information Notice

This manual contains proprietary information that is protected by copyright, and all rights are reserved. No portion of this document may be copied, photocopied, reproduced by any means, or translated into another language without the prior written permission of Pratt & Whitney Engine Services, Inc

Export Control Classification

Contains No Technical Data

	Regulation	Classification Number
* Data is subject to the jurisdiction of the Export and Import Controls Bureau of the Department of Foreign Affairs and International Trade of Canada, Department of Commerce of the United States and/or Department of State of the United States. ** Data is not subject to the jurisdiction of the Department of Commerce of the United States or Department of State of the United States but would become subject if exposed to any US involvement.	Canadian ECL(s)*	
	ECCN(s)*	9E991
	P-ECCN(s)**	
	USML(ITAR)*	

Manual Number:	DTU-G-010-1/B	Cage Code: 16359												
Preparation Date:	09/23/2003	Prepared By: John Lukens, Applications Engineer												
Release Date:	11/07/2003	Last Revised By: Daniel Elsemiller, Applications Engineer												
Revision Date:	06/09/2015	Approvals: <table border="1" style="width: 100%;"> <tr> <td>signature <i>[Signature]</i></td> <td>date <i>6/9/15</i></td> </tr> <tr> <td colspan="2">Jon Miller, Engineering Manager</td> </tr> <tr> <td>signature <i>[Signature]</i></td> <td>date <i>6/09/15</i></td> </tr> <tr> <td colspan="2">Steve Sackos, Supply Chain & QA Manager</td> </tr> <tr> <td>signature</td> <td>date</td> </tr> <tr> <td>signature</td> <td>date</td> </tr> </table>	signature <i>[Signature]</i>	date <i>6/9/15</i>	Jon Miller, Engineering Manager		signature <i>[Signature]</i>	date <i>6/09/15</i>	Steve Sackos, Supply Chain & QA Manager		signature	date	signature	date
signature <i>[Signature]</i>	date <i>6/9/15</i>													
Jon Miller, Engineering Manager														
signature <i>[Signature]</i>	date <i>6/09/15</i>													
Steve Sackos, Supply Chain & QA Manager														
signature	date													
signature	date													
Revision Ltr:	L													
Total Pages:	41													

REVISION HISTORY

Rev Status of Sheets	Rev	L	L	L	L	L	L	L	L	L	L	L	L	L	L	L	L
	Sheet	i	ii	iii	iv	1	2	3	4	5	6	7	8	9	10	11	12
	Rev	L	L	L	L	L	L	L	L	L	L	L	L	L	L	L	L
	Sheet	13	14	15	16	17	18	19	20	21	22	23	24	25	26	27	28
	Rev	L	L	L	L	L	L	L	L	L							
	Sheet	29	30	31	32	33	34	35	36	37							

LOG OF REVISIONS

REV. NO	ECO #	DESCRIPTION	DATE	PAGES REVISED
-		Initial Release	11/07/03	
A		Edit installation instructions for processor mounting and wiring harness routing. Added WOW and power connection tables and reference for mounting location	03/15/04	Cover, i, ii, iii, 4, 5, 6, 8, 10, 13, 14, 15, 18, 19, 20, 21
B		Added ADAS+ Upgrade instructions, diode protection circuit, revised power connections, and ADAS+ Upgrade wiring schematic	04/15/04	Cover, i, ii, iii, 2, 3, 9, 11, 12, 13, 14, 17, 19, 20, 23, 24, 25, 26, 28
C		Added new mounting illustrations and revised Parts List	05/27/04	Cover, i, ii, iii, 4, 5, 6, 7, 8, 9
D		Added new mounting configuration for LAN antenna, and instructions for Installation Summary table, revised Parts List, mounting bracket instructions, and harness installation instructions	06/07/04	Cover, i, ii, iii, 3, 4, 5, 9, 10, 11, 13, 14, 21, 22
E		Revised wiring diagram for ADAS+ Upgrade Monitors and updated photograph for antenna location on Raytheon model aircraft	06/28/04	Cover, i, ii, iii, 13, 23, 24, 25, 31
F	823	Update part numbers and add a kit for the ADAS+ installed on Raytheon Models. Revise the ConXall connector wiring instructions for the download port and DTU Status lamp. Revise Installation Caution regarding the length of wire from the protection device to the power source.	06/03/05	Cover, i – iii, 2 – 32
G	859	Update figures B-2, B-3, and B4 to show correct configuration of the double-stack bracket assembly.	06/14/06	Cover, i, 6, 7
H	962	Updated company name, address and logo. Updated formatting. Corrected spelling and grammar. Updated wire numbers in text, connection charts and schematics.	02/28/08	ALL
J	1008 1017	Add Instructions and Schematics for DTU and ADAS ^d Interface. Correct typographical errors. Remove LAN Antenna References.	03/01/10	ALL
K	1024	Update DTU RF Cable P/N in the Engine Harness Kit. Update Raytheon 300 WOW Connection in the Connection Chart	05/04/10	Cover, i, 3, 30

REV. NO	ECO #	DESCRIPTION	DATE	PAGES REVISED
L	1228	Add DTU Kit for Cessna Caravan that have ADAS ^d installed. Update wiring schematics. Update format of document footer	06/09/2015	ALL

Note: *If the DTU Installation Instructions are revised, all operators will be provided with a copy of the applicable revision. If you have a subscription with TurbineTracker™, you will be informed via email of new revisions to this manual. In addition to this, P&W Engine Services maintains the latest versions of all manuals in the Support Section of TurbineTracker™.*

If you are not a subscriber to TurbineTracker™, you may call P&W Engine Services Customer Support at 781-762-8600 for the latest revision.

TABLE OF CONTENTS

1 P&W ENGINE SERVICES, INC. – GEN III MONITOR APPLICATION..... 1

1.1 SCOPE..... 1

2 INSTALLATION AND MAINTENANCE PROCEDURES 2

2.1 PARTS LIST..... 2

2.1.1 DTU by Parts Kits 2

2.1.2 Components by Kit 3

3 INSTALLATION – MECHANICAL..... 8

3.1 SYSTEM PROCESSOR MOUNTING 8

3.2 DTU STATUS SWITCH/FAULT LAMP AND COMMUNICATIONS PORT..... 14

3.2.1 Status Switch/Fault Lamp..... 14

3.2.2 Download Port 15

3.3 ANTENNA MOUNTING 15

3.4 HARNESS INSTALLATION 16

3.4.1 J1 Harness Installation..... 17

3.4.2 GSM Antenna Cable Installation..... 18

4 INSTALLATION - ELECTRICAL..... 19

4.1 DTU STATUS LAMP AND COMMUNICATIONS PORT WIRING..... 19

4.1.1 DTU Status Lamp Wiring 19

4.1.2 Download Port Connector Wiring..... 21

4.2 AIRFRAME SENSORS 23

4.2.1 On Ground (Weight-on-Wheels) Signal..... 23

4.3 ELECTRICAL POWER 24

4.3.1 Battery Power / Ground Connection 24

4.3.2 Bus (Switched) Power Connection 25

4.4 FINAL INSTALLATION NOTES..... 25

5 HARNESS CONNECTOR SIGNAL PINOUTS..... 27

5.1 ACS CABLE J1, 37 PIN “A” KEYED CONNECTOR 27

5.2 DTU CONNECTION CHART – POWER AND RF LOCKOUT 30

5.2.1 Cessna Caravan Model 208 Series..... 30

5.2.2 Raytheon Model C90..... 30

5.2.3 Raytheon Models 200 & 200T..... 30

5.2.4 Raytheon Models 200CT, A200, A200C, & A200CT..... 31

5.2.5 Raytheon Models B200C, B200CT, B200, B200T..... 31

5.2.6 Raytheon Model 300 Series 31

5.2.7 Raytheon Model B300 Series..... 32

5.2.8 Raytheon Model 1900 & 1900C 32

5.2.9 Raytheon Model 1900D..... 32

6 WIRING DIAGRAM 33

6.1 DTU / ADAS^P INTERCONNECT SCHEMATIC 33

6.2 DTU / ADAS+ INTERCONNECT SCHEMATIC (EXCEPT CESSNA CARAVAN)..... 34

6.3 DTU / ADAS+ INTERCONNECT SCHEMATIC (CESSNA CARAVAN STC INSTALLATION)..... 35

6.4 DTU / ADAS+ INTERCONNECT SCHEMATIC (CESSNA CARAVAN FACTORY INSTALLATION)..... 36

6.5 DTU / ADAS+ UPGRADE INTERCONNECT SCHEMATIC 37

This Document is Subject to the Restrictions Contained on Cover Page
The export control classification with respect to this document is contained on the first page

LIST OF FIGURES

FIGURE B- 1: DTU PROCESSOR.....	8
FIGURE B- 2: DTU/GEN III PROCESSOR TO BRACKET MOUNTING.....	10
FIGURE B- 3: “DOUBLE STACK” MOUNTING CONFIGURATION – HONEYCOMB/SANDWICH PANEL.....	10
FIGURE B- 4: “DOUBLE STACK” MOUNTING CONFIGURATION – METAL SKIN.....	11
FIGURE B- 5: STAND ALONE BRACKET (DPU-D-098-1) TO HONEYCOMB/SANDWICH PANEL (SIDE VIEW)	12
FIGURE B- 6: STAND ALONE BRACKET (DPU-D-098-1) TO METAL SKIN (SIDE VIEW)	13
FIGURE B- 7: DTU STATUS LAMP.....	14
FIGURE B- 8: DTU STATUS LAMP MOUNTING DIMENSIONS	14
FIGURE B- 9: GSM ANTENNA	15
FIGURE B- 10: GSM ANTENNA LOCATION.....	16
FIGURE B- 11: DTU STATUS LAMP CONNECTOR WIRING.....	19
FIGURE B- 12: DTU STATUS LAMP CONNECTOR WIRING (WITH ADAS ^D).....	20
FIGURE B- 13: DOWNLOAD PORT CONNECTOR TO DOWNLOAD PORT – ADAS+	21
FIGURE B- 14: DOWNLOAD PORT CONNECTOR TO GEN III MONITOR – ADAS+	22
FIGURE B- 15: DOWNLOAD PORT CONNECTOR TO GEN III MONITOR – ADAS+ UPGRADE	22
FIGURE B- 16: WOW DIODE ORIENTATION.....	23
FIGURE B- 17: AIRCRAFT BATTERY FINAL WIRING	24
FIGURE B- 18: AIRCRAFT BUS FINAL WIRING.....	25
FIGURE B- 19: DTU / ADAS ^D WIRING SCHEMATIC	33
FIGURE B- 20: DTU / ADAS+ WIRING SCHEMATIC (EXCEPT CESSNA CARAVAN).....	34
FIGURE B- 21: DTU / ADAS+ WIRING SCHEMATIC (CESSNA CARAVAN STC INSTALLATION).....	35
FIGURE B- 22: DTU / ADAS+ WIRING SCHEMATIC (CESSNA CARAVAN FACTORY INSTALLATION).....	36
FIGURE B- 23: DTU / ADAS+ UPGRADE WIRING SCHEMATIC	37

LIST OF TABLES

TABLE B- 1: DTU CONNECTION CHART CESSNA CARAVAN MODEL 208 SERIES	30
TABLE B- 2: DTU CONNECTION CHART RAYTHEON MODEL C90	30
TABLE B- 3: DTU CONNECTION CHART RAYTHEON MODEL 200 & 200T	30
TABLE B- 4: DTU CONNECTION CHART RAYTHEON MODEL 200CT, A200, A200C, & A200CT.....	31
TABLE B- 5: DTU CONNECTION CHART RAYTHEON MODEL B200C, B200CT, B200, & B200T	31
TABLE B- 6: DTU CONNECTION CHART RAYTHEON MODEL 300 SERIES	31
TABLE B- 7: DTU CONNECTION CHART RAYTHEON MODEL B300 SERIES.....	32
TABLE B- 8: DTU CONNECTION CHART RAYTHEON MODEL 1900 & 1900C.....	32
TABLE B- 9: DTU CONNECTION CHART RAYTHEON MODEL 1900D SERIES	32

1 P&W ENGINE SERVICES, INC. – GEN III MONITOR APPLICATION

1.1 Scope

The purpose of this document is to provide users of this product with P&W Engine Services approved installation instructions for the Data Transmission Unit (DTU). Any deviation from the procedures described within this document could result in a failure of the product to perform properly and could possibly result in damage to other systems of the aircraft.

These instructions apply to the aircraft associated with existing Pratt & Whitney Engine Services, Inc., Generation III monitoring systems.

2 INSTALLATION AND MAINTENANCE PROCEDURES

2.1 Parts List

For Pratt & Whitney Engine Services, Inc. – Generation III Monitors:

The parts listed below consist of the installation kits for the DTU used on Pratt & Whitney Engine Services, Inc. Generation III monitors. Assembly kit numbers are listed in section 2.1.1 and individual components are detailed by kit numbers in section 2.1.2.

2.1.1 DTU by Parts Kits

For ADAS^d Monitors Installed on Raytheon Models: Qty P/N DTU-K-010-22 Weight

Processor Assembly	1	DTU-K-089-2	2.00 Lbs.
Engine Harness Kit	1	DTU-K-090-5	2.40 Lbs.
Fault Lamp Assembly Kit	1	DTU-K-091-2	0.50 Lbs.
Antenna Kit	1	DTU-K-092-2	0.20 Lbs
Additional Installation Materials Kit	1	DTU-K-093-20	0.20 Lbs

For ADAS+ Monitors Installed on Raytheon Models: Qty P/N DTU-K-010-6 Weight

Processor Assembly	1	DTU-K-089-2	2.00 Lbs.
Engine Harness Kit	1	DTU-K-090-2	2.40 Lbs.
Fault Lamp Assembly Kit	1	DTU-K-091-2	0.50 Lbs.
Antenna Kit	1	DTU-K-092-2	0.20 Lbs
Additional Installation Materials Kit	1	DTU-K-093-5	0.20 Lbs.

For ADAS+ Monitors Installed on Cessna Models: Qty P/N DTU-K-010-2 Weight

Processor Assembly	1	DTU-K-089-2	2.00 Lbs.
Engine Harness Kit	1	DTU-K-090-2	2.40 Lbs.
Fault Lamp Assembly Kit	1	DTU-K-091-2	0.50 Lbs.
Antenna Kit	1	DTU-K-092-2	0.20 Lbs
Additional Installation Materials Kit	1	DTU-K-093-2	0.20 Lbs.

For ADAS^d Monitors Installed on Cessna Models: Qty P/N DTU-K-010-26 Weight

Processor Assembly	1	DTU-K-089-15	2.00 Lbs.
Engine Harness Kit	1	DTU-K-090-18	2.40 Lbs.
Fault Lamp Assembly Kit	1	DTU-K-091-2	0.50 Lbs.
Antenna Kit	1	DTU-K-092-2	0.20 Lbs
Additional Installation Materials Kit	1	DTU-K-093-21	0.20 Lbs.

For ADAS+ Upgrade Monitors Only:	Qty	P/N DTU-K-010-3	Weight
Processor Assembly	1	DTU-K-089-2	2.00 Lbs.
Engine Harness Kit	1	DTU-K-090-2	2.40 Lbs.
Fault Lamp Assembly Kit	1	DTU-K-091-2	0.50 Lbs.
Antenna Kit	1	DTU-K-092-2	0.20 Lbs
Additional Installation Materials Kit	1	DTU-K-093-3	0.10 Lbs.

2.1.2 Components by Kit

For ADAS ^d Monitors Installed on Raytheon Models:
--

PROCESSOR ASSEMBLY KIT	DTU-K-089-2
-------------------------------	--------------------

Processor, Standalone	DTU-A-012-1	Qty 1
Bracket, Mounting (Dual Assembly)	DPU-D-080-1	Qty 1
Plate Bracket Assembly	DPU-A-082-1	Qty 1
Bracket, Low Profile Mntg (Stand Alone)	DPU-D-098-1	Qty 1
Shock Mounts, Lord	990-00020	Qty 4
Washer, Processor Mount	920-00006	Qty 4
Nut, Locking, Processor Mount	MS21042-06	Qty 4
Screw, Mount	MS35207-261	Qty 10
Insert	NAS1836-3-09	Qty 6
Strap, Ground	DPU-C-050-1	Qty 1

FAULT LAMP ASSEMBLY	DTU-K-091-2
----------------------------	--------------------

Assy., Split Lamp	ADAS-A-011-1	Qty 1
Lens, Switch, Dual Lamp, DTU	DTU-D-082-1	Qty 1
Connector, 6 Pin Female	400-00026	Qty 1

ENGINE HARNESS KIT	DTU-K-090-5
---------------------------	--------------------

Cable Assembly, DTU ACS, J1	DAAS-C-040-1	Qty 1
RF, DTU, Rt. Angle-Straight	DTU-C-078-1	Qty 1
Cable RF, DTU, 2X Rt. Angle	DTU-C-084-3	Qty 1

ANTENNA KIT	DTU-K-092-2
--------------------	--------------------

Antenna, GSM	DTU-D-094-1	Qty 1
Conn, Dust Cap, SMA Male	400-00136	Qty 1

ADDITIONAL MATERIAL INSTALLATION KIT	DTU-K-093-20
---	---------------------

Mntg Plate DTU Fault Lamp/Dnld Port	DTU-D-104-1	Qty 1
SPACER, NYLON #6	940-00015	Qty 4
Bracket, Antenna	DTU-D-106-1	Qty 1
Plug, Finishing 9/16"	990-00121	Qty 1

For ADAS+ Monitors Installed on Raytheon Models:

PROCESSOR ASSEMBLY KIT		DTU-K-089-2
Processor, Standalone	DTU-A-012-1	Qty 1
Bracket, Mounting (Dual Assembly)	DPU-D-080-1	Qty 1
Plate Bracket Assembly	DPU-A-082-1	Qty 1
Bracket, Low Profile Mntg (Stand Alone)	DPU-D-098-1	Qty 1
Shock Mounts, Lord	990-00020	Qty 4
Washer, Processor Mount	920-00006	Qty 4
Nut, Locking, Processor Mount	MS21042-06	Qty 4
Screw, Mount	MS35207-261	Qty 10
Insert	NAS1836-3-09	Qty 6
Strap, Ground	DPU-C-050-1	Qty 1
FAULT LAMP ASSEMBLY		DTU-K-091-2
Assy., Split Lamp	ADAS-A-011-1	Qty 1
Lens, Switch, Dual Lamp, DTU	DTU-D-082-1	Qty 1
Connector, 6 Pin Female	400-00026	Qty 1
ENGINE HARNESS KIT		DTU-K-090-2
Cable Assembly, DTU ACS, J1	DTU-C-075-1	Qty 1
RF, DTU, Rt. Angle-Straight	DTU-C-078-1	Qty 1
Cable RF, DTU, 2X Rt. Angle	DTU-C-084-1	Qty 1
ANTENNA KIT		DTU-K-092-2
Antenna, GSM	DTU-D-094-1	Qty 1
Conn, Dust Cap, SMA Male	400-00136	Qty 1
ADDITIONAL MATERIAL INSTALLATION KIT		DTU-K-093-5
Fuse, 1.0 Amp	990-00033	Qty 2
Fuse Holder	DPU-C-057-1	Qty 2
Connector, 6 Pin Male	400-00027	Qty 1
Connector, 6 Pin Female	400-00026	Qty 1
Velcro®	990-00079	Qty 2 Ft
Diode	300-00034	Qty 2
Mntg Plate DTU Fault Lamp/Dnld Port	DTU-D-104-1	Qty 1
SPACER, NYLON #6	940-00015	Qty 4
Bracket, Antenna	DTU-D-106-1	Qty 1

For ADAS+ Monitors Installed on Cessna Models:

PROCESSOR ASSEMBLY KIT DTU-K-089-2

Processor, Standalone	DTU-A-012-1	Qty 1
Bracket, Mounting (Dual Assembly)	DPU-D-080-1	Qty 1
Plate Bracket Assembly	DPU-A-082-1	Qty 1
Bracket, Low Profile Mntg (Stand Alone)	DPU-D-098-1	Qty 1
Shock Mounts, Lord	990-00020	Qty 4
Washer, Processor Mount	920-00006	Qty 4
Nut, Locking, Processor Mount	MS21042-06	Qty 4
Screw, Mount	MS35207-261	Qty 10
Insert	NAS1836-3-09	Qty 6
Strap, Ground	DPU-C-050-1	Qty 1

FAULT LAMP ASSEMBLY DTU-K-091-2

Assy., Split Lamp	ADAS-A-011-1	Qty 1
Lens, Switch, Dual Lamp, DTU	DTU-D-082-1	Qty 1
Connector, 6 Pin Female	400-00026	Qty 1

ENGINE HARNESS KIT DTU-K-090-2

Cable Assembly, DTU ACS, J1	DTU-C-075-1	Qty 1
RF, DTU, Rt. Angle-Straight	DTU-C-078-1	Qty 1
Cable RF, DTU, 2X Rt. Angle	DTU-C-084-1	Qty 1

ANTENNA KIT DTU-K-092-2

Antenna, GSM	DTU-D-094-1	Qty 1
Conn, Dust Cap, SMA Male	400-00136	Qty 1

ADDITIONAL MATERIAL INSTALLATION KIT DTU-K-093-2

Fuse, 1.0 Amp	990-00033	Qty 2
Fuse Holder	DPU-C-057-1	Qty 2
Connector, 6 Pin Male	400-00027	Qty 1
Connector, 6 Pin Female	400-00026	Qty 1
Velcro®	990-00079	Qty 2 Ft
Diode	300-00034	Qty 2
Mntg Plate DTU Fault Lamp/Dnld Port	DTU-D-104-1	Qty 1

For ADAS^d Monitors Installed on Cessna Models:

PROCESSOR ASSEMBLY KIT DTU-K-089-15

Processor, Standalone	DTU-A-012-1	Qty 1
Bracket, Low Profile Mntg (Stand Alone)	DPU-D-098-1	Qty 1
Shock Mounts, Lord	990-00020	Qty 4
Washer, Processor Mount	920-00006	Qty 4
Nut, Locking, Processor Mount	MS21042-06	Qty 4
Screw, Mount	MS35207-261	Qty 10
Strap, Ground	DPU-C-050-1	Qty 1

FAULT LAMP ASSEMBLY DTU-K-091-2

Assy., Split Lamp	ADAS-A-011-1	Qty 1
Lens, Switch, Dual Lamp, DTU	DTU-D-082-1	Qty 1
Connector, 6 Pin Female	400-00026	Qty 1

ENGINE HARNESS KIT DTU-K-090-18

Cable Assembly, DTU ACS, J1	DAAS-C-040-2	Qty 1
Cable RF, DTU, 2X Rt. Angle	DTU-C-084-1	Qty 1

ANTENNA KIT DTU-K-092-2

Antenna, GSM	DTU-D-094-1	Qty 1
Conn, Dust Cap, SMA Male	400-00136	Qty 1

ADDITIONAL MATERIAL INSTALLATION KIT DTU-K-093-21

Connector, 6 Pin Male	400-00027	Qty 1
Connector, 6 Pin Female	400-00026	Qty 1
Velcro®	990-00079	Qty 2 Ft
Mntg Plate DTU Fault Lamp/Dnld Port	DTU-D-104-1	Qty 1
Plug, Finishing 9/16"	990-00121	Qty 1
Terminal Ring #10	MS25036-103	Qty 1
Rivet Nut	NAS1329A3K80	Qty 8

For ADAS+ Upgrade Monitors Only:

PROCESSOR ASSEMBLY KIT DTU-K-089-2

Processor, Standalone	DTU-A-012-1	Qty 1
Bracket, Mounting (Dual Assembly)	DPU-D-080-1	Qty 1
Plate Bracket Assembly	DPU-A-082-1	Qty 1
Bracket, Low Profile Mntg (Stand Alone)	DPU-D-098-1	Qty 1
Shock Mounts, Lord	990-00020	Qty 4
Washer, Processor Mount	920-00006	Qty 4
Nut, Locking, Processor Mount	MS21042-06	Qty 4
Screw, Mount	MS35207-261	Qty 10
Insert	NAS1836-3-09	Qty 6
Strap, Ground	DPU-C-050-1	Qty 1

FAULT LAMP ASSEMBLY DTU-K-091-2

Assy., Split Lamp	ADAS-A-011-1	Qty 1
Lens, Switch, Dual Lamp, DTU	DTU-D-082-1	Qty 1
Connector, 6 Pin Female	400-00026	Qty 1

ENGINE HARNESS KIT DTU-K-090-2

Cable Assembly, DTU ACS, J1	DTU-C-075-1	Qty 1
RF, DTU, Rt. Angle-Straight	DTU-C-078-1	Qty 1
Cable RF, DTU, 2X Rt. Angle	DTU-C-084-1	Qty 1

ANTENNA KIT DTU-K-092-1

Antenna, GSM	DTU-D-094-1	Qty 1
Antenna, RF	DTU-D-095-1	Qty 1
Conn, Adapter Jack to Jack	960-00048	Qty 1

ADDITIONAL MATERIAL INSTALLATION KIT DTU-K-093-3

Fuse, 1.0 Amp	990-00033	Qty 2
Fuse Holder	DPU-C-057-1	Qty 2
Connector, 6 Pin Male	400-00027	Qty 1
Velcro®	990-00079	Qty 2 Ft
Diode	300-00034	Qty 2
Harness	TWIN-C-080-1	Qty 1
Bracket, Antenna	DTU-D-106-1	Qty 1
Mntg Plate DTU Fault Lamp/Dnld Port	DTU-D-104-1	Qty 1
Spacer	940-00015	Qty 4

3 INSTALLATION – MECHANICAL

3.1 System Processor Mounting

The system processor (Figure B- 1) may be remotely mounted. The processor will not require access during normal operation. P&W Engine Services offers three mounting bracket options. For aircraft with ample space in the location of the previously installed Generation III processor (IntelliStart+, SmartCycle+, ADAS^d, ADAS+, and TrendCheck+), the utilization of the double stack bracket (DPU-D-080-1 and DPU-A-082-1) is recommended. For aircraft with limited clearance, the low profile bracket (DPU-D-098-1) is recommended. DPU-D-030-1 is the bracket utilized in ADAS+, SmartCycle+, and IntelliStart+ installations. DPU-D-082-1 is the bracket utilized in the ADAS^d installation.



Figure B- 1: DTU Processor

Note: The aircraft and available space will determine how the DTU will be installed. With the supplied mounting brackets the DTU can be mounted in two different configurations.

1. If the current location of the Gen III processor has sufficient space the DTU can be mounted in the “Double stack” configuration. Refer to Figure B- 3 or Figure B- 4.
2. If the current location of the Gen III processor does not have sufficient space, the DTU can be mounted in another location using the Low Profile Bracket (DPU-D-098-1). See Figure B- 5 or Figure B- 6. Refer to the applicable aircraft maintenance manual for specific instructions regarding standard practices for structural mounting.
3. The location of the processor must be recorded in the Installation Summary Table provide in Instructions for Continued Airworthiness, DTU-G-260-1/B, Section 7.1

INSTALLATION CAUTION:

- ⇒ If another area is used to mount the DTU, the area must have sufficient structural integrity to support the unit. Sheet metal panels should be .025” thick, with material comparable or stronger than 2024-T3 aluminum.
- ⇒ When installing in a sandwich panel, an undercut shall be made around the periphery of the insert hole to spoil the core in the area immediately around the insert hole. The panel shall be a minimum of .50” thick.
- ⇒ The area chosen must be inspected for any evidence of dents, contraction, cracking, and deterioration of metal. Reference AC 43.13-2A, Chapters 1 & 2 for specific guidelines in determining a mounting location.
- ⇒ The area chosen must allow full and free movement of any control system cables or tubes. The control mechanisms must be able to operate over their complete range of movement.
- ⇒ The DTU processor is not certified to be mounted in the engine compartment.

For **Bracket Mounting Option 1 – Double Stack (except for ADAS^d)**

The system processors shall be mounted in accordance with the following procedure:

- 010 Remove the Gen III processor and its mounting bracket from the aircraft. Discard the original mounting bracket.
- 020 Ensure that the original inserts securing the bracket to the honeycomb panel are NAS1836-3 or equivalent.
- 030 **For installations in a honeycomb/sandwich panel**, using the supplied mounting bracket (DPU-A-082-1) as a template, mark the location of the 2 additional mounting holes and drill to accommodate a NAS1836-3 potted insert.
- 040 Install six (6) NAS1836-3 potted inserts in accordance with manufacturer's instructions
- 050 **For installations in a metal skin**, using the supplied mounting bracket (DPU-A-082-1) as a template, mark the location of the two (2) additional mounting holes and drill to accommodate a #10 screw.
- 060 Assemble the DTU and Gen III processors to the mounting bracket as shown in Figure B- 2

INSTALLATION CAUTION:

⇒ **Excessive torque on the processor-mounting studs can deform shock mounts. The locking nut should be tightened to the point of contact with the shock mount.**

- 070 Assemble the "Double Stack" mounting bracket and install the Gen III processor and the DTU processor. Refer to applicable Figure B- 3 or Figure B- 4
- 080 Install ground strap DPU-C-050-2 between one of the processor-mounting studs and the aircraft chassis for both the Gen III and DTU processors
- 090 Mount the "Double Stack" bracket containing the Gen III processor and the DTU to the aircraft using the required hardware.

For **Bracket Mounting Option 1 – Double Stack (ADAS^d Only)**

The system processors shall be mounted in accordance with the following procedure:

- 010 Assemble the DTU to the "Double Stack" mounting bracket P/N DPU-D-080-1, as shown in Figure B- 2.

INSTALLATION CAUTION:

⇒ **Excessive torque on the processor-mounting studs can deform shock mounts. The locking nut should be tightened to the point of contact with the shock mount.**

- 020 Attach the DTU and the "Double Stack" mounting bracket to the Gen III processor bracket using the required hardware. Refer to applicable Figure B- 3 or Figure B- 4
- 030 Install ground strap DPU-C-050-2 between one of the processor-mounting studs and the aircraft chassis for both the Gen III and DTU processors

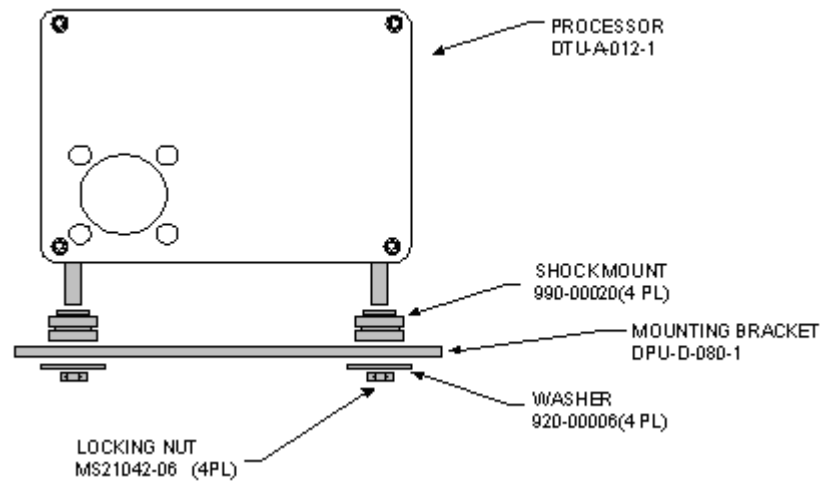

Figure B- 2: DTU/Gen III Processor to Bracket Mounting

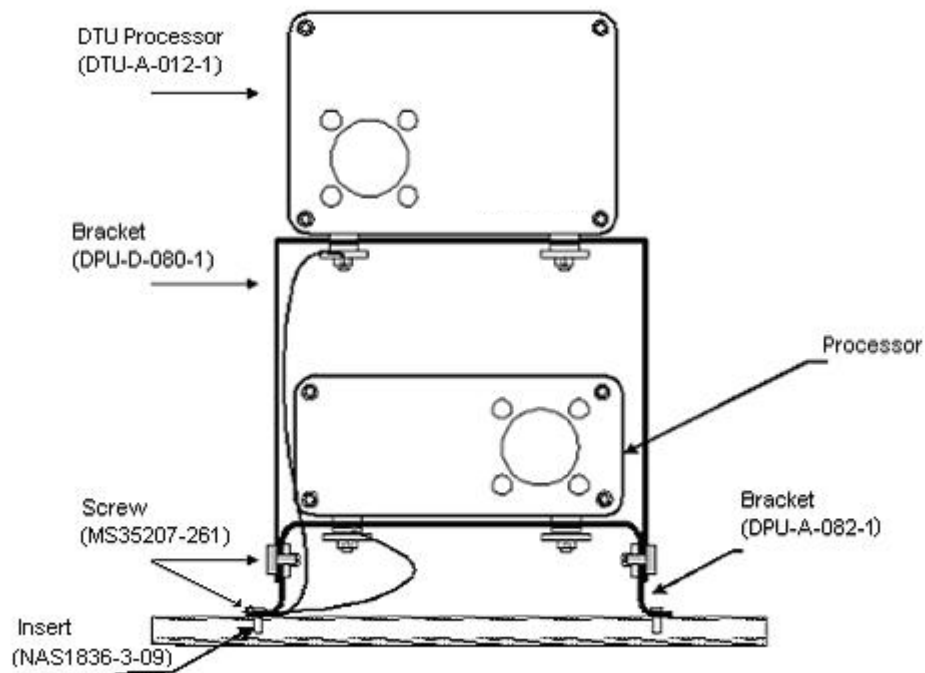

Figure B- 3: "Double Stack" Mounting Configuration – Honeycomb/Sandwich Panel

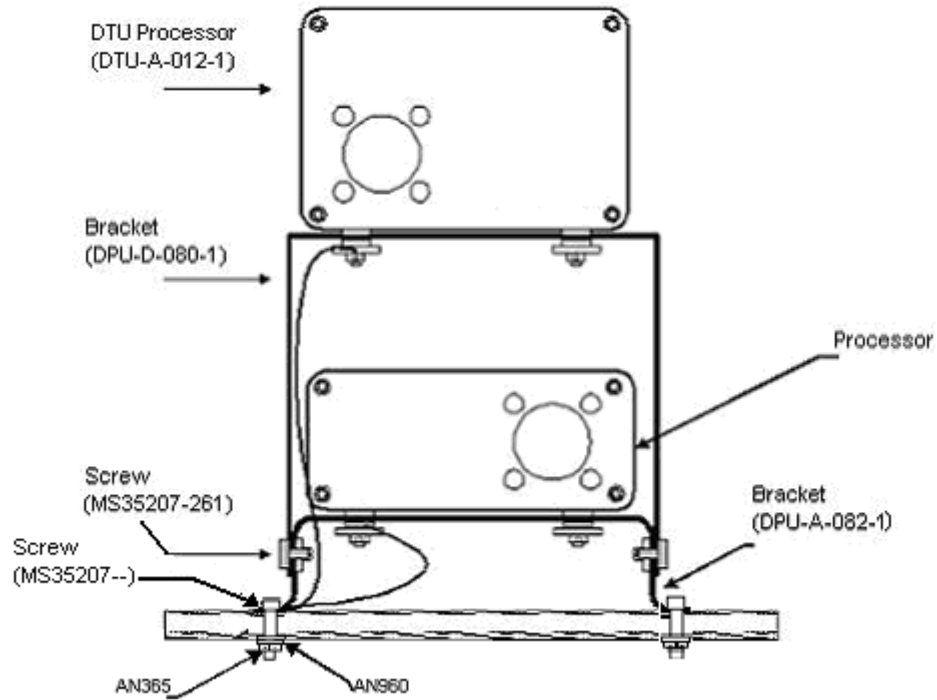

Figure B- 4: "Double Stack" Mounting Configuration – Metal Skin

For **Bracket Mounting Option 2 – Stand Alone**

The system processor shall be mounted in accordance with the following procedure:

- ❑ 010 **For installations in a honeycomb/sandwich panel**, when a location has been determined for the DTU processor, using the supplied mounting bracket (DPU-D-098-1) as a template, mark the location of the four (4) holes and drill to accommodate a NAS1836-3 potted insert.
- ❑ 020 Install four (4) NAS1836-3 potted inserts in accordance with manufacturer's instructions
- ❑ 030 **For installations in a metal skin**, when a location has been determined for the DTU processor, using the supplied mounting bracket (DPU-D-098-1) as a template, mark the location of the four (4) mounting holes and drill to accommodate a #10 screw.
- ❑ 040 Assemble the DTU processor to the mounting bracket as shown in Figure B- 2
- ❑ 050 Install ground strap DPU-C-050-1 between one of the processor mounting studs and the aircraft chassis.
- ❑ 060 Mount the DTU processor and bracket using the required hardware. Refer to applicable Figure B- 5 or Figure B- 6.

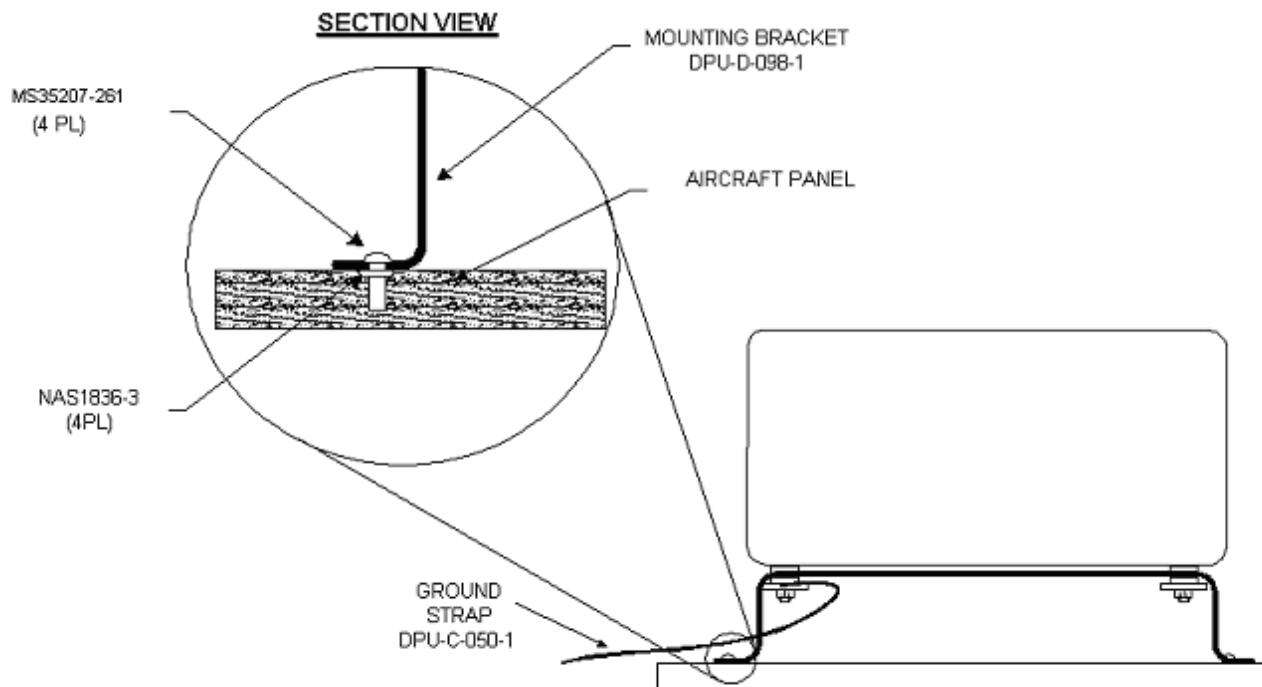

Figure B- 5: Stand Alone Bracket (DPU-D-098-1) to Honeycomb/Sandwich Panel (Side View)

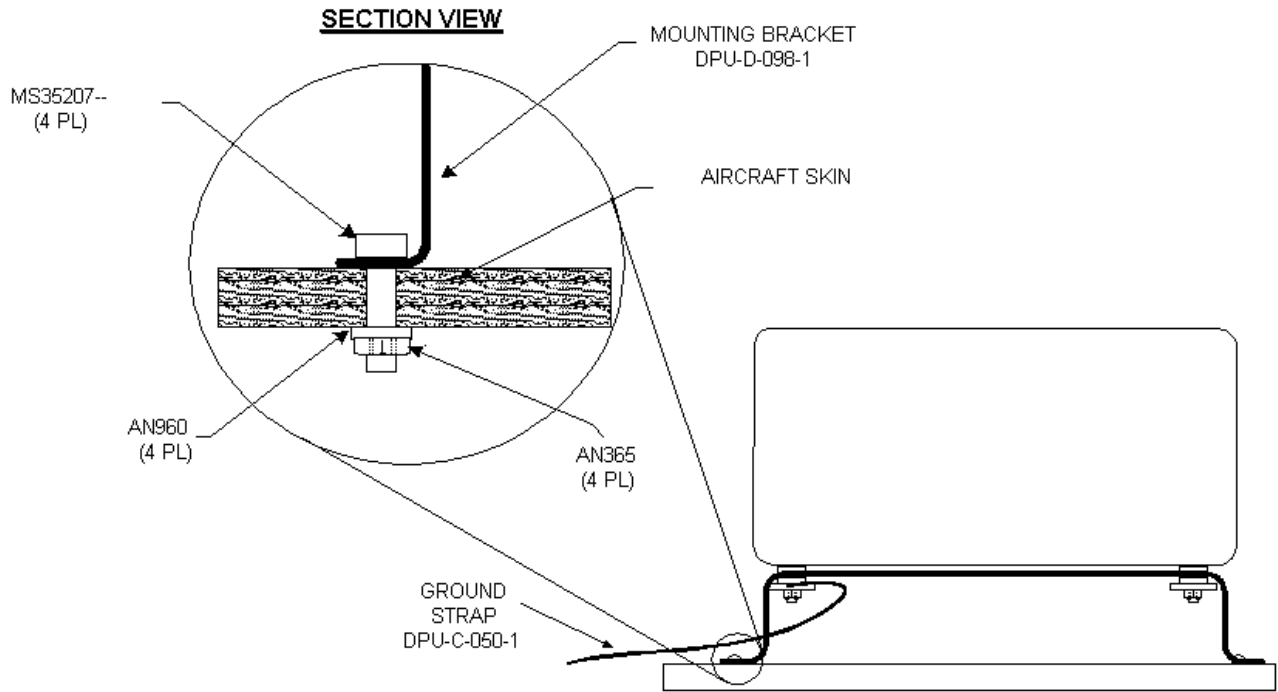

Figure B- 6: Stand Alone Bracket (DPU-D-098-1) to Metal Skin (Side View)

3.2 DTU Status Switch/Fault Lamp and Communications Port

3.2.1 Status Switch/Fault Lamp

Assembly Notes

The DTU has a status switch / fault lamp, which consists of a rectangular push-to-test combination lamp (Figure B- 7). The location of the DTU Status/Fault Lamp must be recorded in the Installation Summary Table provide in Instructions for Continued Airworthiness, DTU-G-260-1/B, Section 7.1

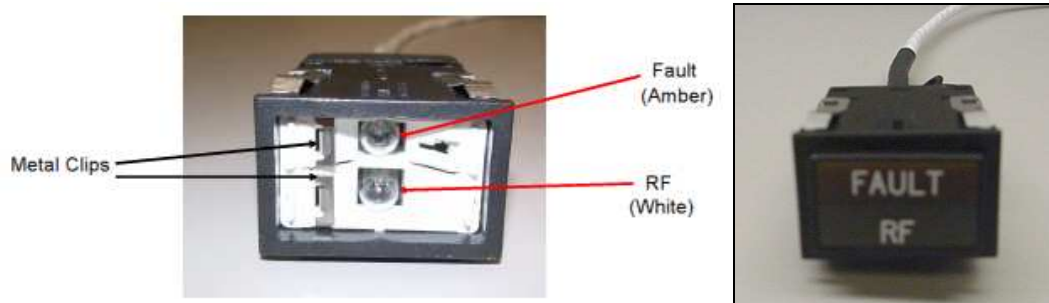

Figure B- 7: DTU Status Lamp

INSTALLATION CAUTION:

- ⇒ *The DTU Status lamp should be mounted in a location accessible to maintenance personnel.*
- ⇒ *If a suitable location is available, the supplied lamp mounting bracket (DTU-D-104-1) can be used to remotely mount the DTU Status Lamp.*
- ⇒ *The DTU Status lamp is not certified to be mounted in the cockpit.*

- ❑ 010 If the double stack configuration is used, the lamp can be mounted on the DTU processor mounting bracket (DPU-D-080-1) using the supplied lamp mounting bracket (DTU-D-104-1).
- ❑ 020 Using the lamp mounting bracket as a template, mark and drill the three (3) #10 mounting holes on the processor mounting bracket.
- ❑ 030 Secure the lamp mounting bracket to the processor mounting bracket.
- ❑ 040 Install the DTU Status Lamp into the bracket.
- ❑ 050 If the lamp cannot be mounted on the DTU processor mounting bracket, find a suitable location and following Figure B- 8, mark and punch a 1.14 x 0.75 inch rectangular hole for mounting of the Status Lamp.
- ❑ 060 Install the DTU Status Lamp into the panel.

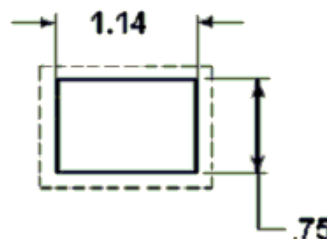

Figure B- 8: DTU Status Lamp Mounting Dimensions

3.2.2 Download Port

The DTU will wire into the existing download port installed in the aircraft from the previously installed Generation III system.

3.3 Antenna Mounting

For ADAS+ Monitors Only (Except Raytheon Models):

The DTU incorporates a GSM antenna that will be mounted internal to the airframe. Velcro® is used to attach the GSM antenna to the mounting surface. The location of the GSM antenna must be recorded in the Installation Summary Table provide in Instructions for Continued Airworthiness, DTU-G-260-1/B, Section 7.1

INSTALLATION CAUTION:

- ⇒ *The specific mounting location is important due to curvatures and uneven surfaces that can be found on various aircraft. A flat surface is the desired GSM antenna mounting location.*
 - ⇒ *The installer must ensure that the antenna is not mounted in a location totally encompassed by metal*
 - ⇒ *If the antenna is mounted in the cabin of the aircraft it must be securely fastened to the aircraft to prevent their movement during a hard landing. The preferred method is to mount the antenna in a secondary containment area.*
-
- 010 The surface that will come in contact with the Velcro® tape must be free of paint, dust, oil, grease, and other contamination prior to antenna installation. Clean the aircraft surface thoroughly.
 - 020 Cut the supplied Velcro® tape to the length of the GSM antenna (Figure B- 9) and remove the release film.
 - 030 Firmly press the tape to the aircraft panel.
 - 040 Cut the supplied Velcro® tape to the length of the GSM antenna and remove the release film.
 - 050 Firmly press the tape to the back of the GSM antenna. The front of the GSM antenna is identified by the coaxial connector mounting and the identification label. Figure B- 9 shows the front of the GSM antenna.
 - 060 Mount GSM antenna to the Velcro® tape installed on the aircraft panel by firmly pressing the antenna to the tape.



Figure B- 9: GSM Antenna

For All Gen III Monitors (Raytheon Models Only):

The DTU incorporates a GSM antenna that will be mounted internal to the airframe. A supplied mounting bracket is used to attach the GSM antenna to the mounting surface.

INSTALLATION CAUTION:

- ⇒ *The specific mounting location is important due to curvatures and uneven surfaces that can be found on various aircraft.*
- ⇒ *The installer must ensure that the antenna are not mounted in a location totally encompassed by metal*

- 010 Remove the fiberglass nose cover from the nose of the aircraft
- 020 Locate the GSM antenna mounting bracket (DTU-D-106-1) as shown in Figure B- 10. Using the bracket as a template mark and drill two mounting holes to accommodate a #10 screw.
- 030 Secure the GSM antenna to the mounting bracket using the supplied hardware and spacers.
- 040 Secure the mounting bracket assembly to the aircraft.

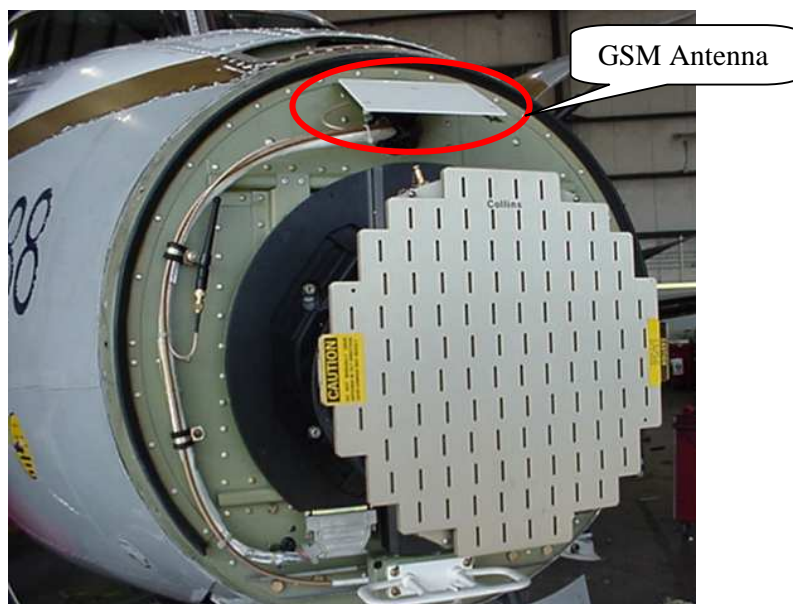

Figure B- 10: GSM Antenna Location

3.4 Harness Installation

INSTALLATION CAUTION:

- ⇒ *Route all cables to follow existing wiring harnesses. Ensure that all cables and individual wires do not interfere with any control cables. Secure all cables and wires with cable ties and where necessary, use spiral tubing to protect wires from chaffing and abrasion. Do not secure cables to any existing power cable.*
- ⇒ *Avoid sharp bends and routing RF cable near high energy sources*

3.4.1 J1 Harness Installation

For ADAS^d Monitors Only:

- 010 Connect the J1 harness to the J1 connector on the DTU processor.
- 020 Disconnect the existing 10 Pin Lemo connector (J2) from the ADAS^d. Route the DAAS-C-040 (10 pin Lemo connector “male”) cable from the DTU and connect to the ADAS^d (J2).
- 030 Route the AAB49B24 cable (10 pin Lemo connector “female”) to the ADAS^d and connect it to the AAB40D24 cable (10 pin Lemo connector “male”) that was previously removed from the ADAS^d.
- 040 Route the AAV39E24 cable to the DTU Status Lamp.
- 050 Route the AAD09A24 cable to airframe ground.

For ADAS+ Monitors Only:

- 010 Connect the J1 harness to the J1 connector on the DTU processor.
- 020 Route the AAV09B24 cable and connect the “WHT” wire to a source that has “Hot” battery power all the time. The “WHT/BLU” wire is connected to aircraft ground. Refer to Section 5.2 for your specific aircraft model wiring.
- 030 Route the AAV19A24 cable and connect the “WHT” wire to a source that has “Switched on” battery power. Refer to Section 5.2 for your specific aircraft model wiring.
- 040 Route the AAD09A24 cable to a weight on wheels switch (WOW). Refer to Section 5.2 for your specific aircraft model wiring.
NOTE: Cessna Caravan installations will connect this wire to aircraft ground per section 5.2.
- 050 Route the AAB49B24 cable coming from the DTU to the existing Download Port.
- 060 Disconnect the ConXall™ connector from the existing Download Port to the Gen III processor and connect the Download Port to the ConXall™ connector on the AAB49B24 cable.
- 070 Route the AAB48C24 cable to the GEN III cable previously connected to the Download Port and assemble the ConXall™ of the AAB48C24 cable to the existing Gen III processor cable.
- 080 Route the AAV39D24 & AAV38A24 cables to the installed DTU Status Lamp.

For ADAS+ Upgrade Monitors Only:

- 010 Connect the J1 harness to the J1 connector on the DTU processor.
- 020 Split the harness and route the AAV09B24 cable and connect the "WHT" wire to a source that has "Hot" battery power all the time. The "WHT/BLU" wire is connected to aircraft ground.
- 030 Route the AAV19A24 cable and connect the "WHT" wire to a source that has "Switched on" battery power.
- 040 Route the AAD09A24 cable to a weight on wheels switch (WOW).
- 050 Route the AAB49B24 and the AAB48C24 connector cables coming from the DTU processor to the ADAS+ Upgrade processor.
- 060 Route the AAV39D24 cable to the installed DTU Status Lamp.

3.4.2 GSM Antenna Cable Installation

- 010 Connect the GSM antenna cable to the DTU processor GSM connection. Torque SMA Connector to 5 inch pounds or 56 N-cm. The GSM antenna cable is the one with a 90° connection on both ends.
- 020 Route the GSM cable (90° connector) to the GSM antenna. Torque SMA Connector to 5 inch pounds or 56 N-cm.

4 INSTALLATION - ELECTRICAL

4.1 DTU Status Lamp and Communications Port Wiring

4.1.1 DTU Status Lamp Wiring

Wiring Notes:

ConXall™ connectors are installed in this and the next section. The following tools are recommended by the vendor for use with these connectors (vendor P/Ns): Insertion Bit (356-20), Pin Removal Bit (356-201), Socket Removal Bit (356-202), Handle (356-1), Crimp Tool (359-21), Locator (357-122). The vendor address is: ConXall Corporation, 601 East Wildwood, Villa Park, IL 60181.

For All Gen III Monitors (except ADAS^d):

INSTALLATION CAUTION:

⇒ *The DTU Status Lamp and the Download Port cables both use 6 pin connectors. The DTU Status Lamp cable uses a socket connector (6SG type) and the Download Port cable uses a pin connector (6PG type). Be sure to use the correct connector with the appropriate cable.*

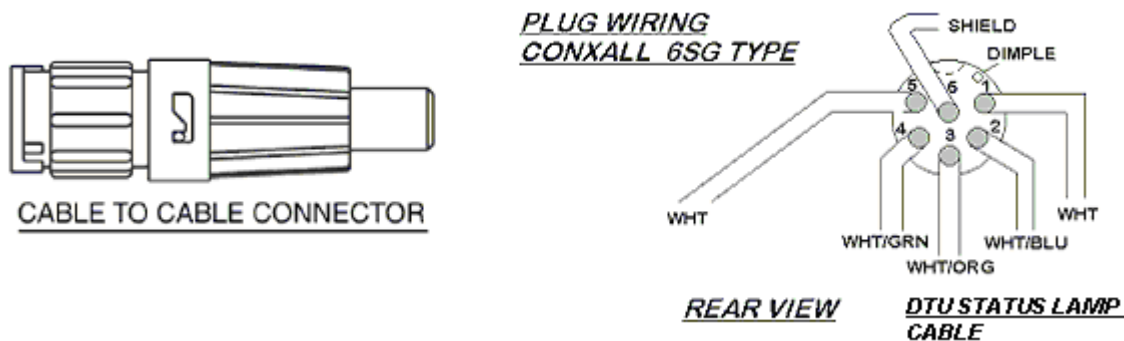

Figure B- 11: DTU Status Lamp Connector Wiring

Wiring Instructions

- ❑ 010 Trim the Ind Sw “AAV39D24” cable to length, and slide the correct ConXall™ connector backshell parts onto the cable.
- ❑ 020 Refer to the illustration Figure B- 11 and connect the cable to the included ConXall™ connector using the socket configuration shown. Splice a short wire lead to the cable shield with a shrink-on solder sleeve to make the Pin 6 shield connection.
- ❑ 030 Assemble the backshell to the connector, connect it to the lamp, and secure all wiring.

For ADAS^d Monitors:

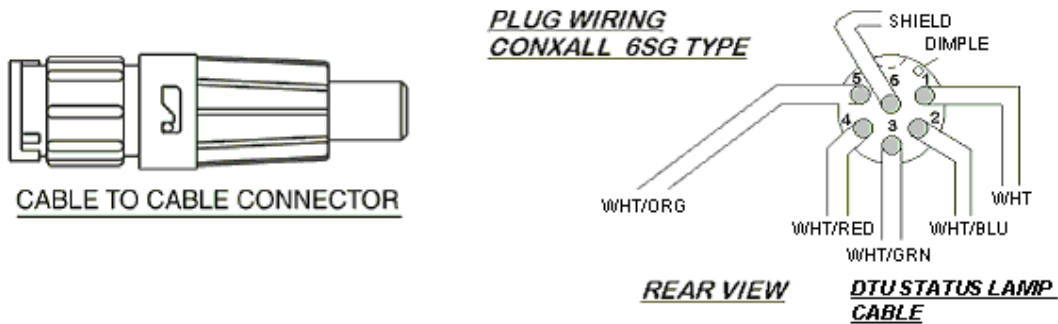

Figure B- 12: DTU Status Lamp Connector Wiring (with ADAS^d)

Wiring Instructions

- ❑ 010 Trim the Ind Sw “AAV39E24” cable to length, and slide the correct ConXall™ connector backshell parts onto the cable.
- ❑ 020 Refer to the illustration Figure B- 12 and connect the cable to the included ConXall™ connector using the socket configuration shown. Splice a short wire lead to the cable shield with a shrink-on solder sleeve to make the Pin 6 shield connection.
- ❑ 030 Assemble the backshell to the connector, connect it to the lamp, and secure all wiring.

4.1.2 Download Port Connector Wiring

For ADAS+ Monitors Only:

INSTALLATION CAUTION:

- ⇒ *The connections to the Download Port cables (DL PORT and G3 MONITOR) use a pin connector (6PG type) and a socket connector (6SG type). Be sure to use the correct connector with the appropriate cable.*

Wiring Instructions

- ❑ 010 Trim the DL PORT “AAB49B24” connector cable to length, and slide the 6PG type ConXall™ connector backshell parts onto the cable. This connector will connect to the existing Download Port connector mounted in the aircraft.
- ❑ 020 Refer to the illustration in Figure B- 13, and connect the cable to the included ConXall™ plug connector using the illustrated pin configuration. Pin 1 is identified by a dimple. Pins 3, 4, and 5 have no connection. Splice a short wire lead to the cable shield with a shrink-on solder sleeve to make the Pin 6 shield connection
- ❑ 030 Assemble the backshell to the connector, connect it to the port, and secure all wiring.

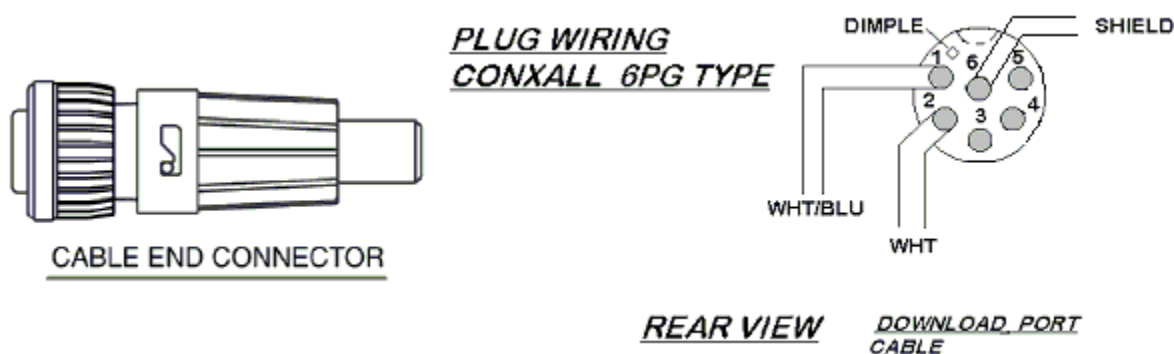

Figure B- 13: Download Port Connector to Download Port – ADAS+

- ❑ 040 Trim the G3 MONITOR “AAB48C24” connector cable to length, and slide the 6SG type ConXall™ connector backshell parts onto the cable. This connector will connect to the existing ConXall™ connector coming from the GEN III processor
- ❑ 050 Refer to the illustration in Figure B- 14, and connect the cable to the included ConXall™ plug connector using the illustrated pin configuration. Pin 1 is identified by a dimple. Pins 3 and 5 have no connection. Splice a short wire lead to the cable shield with a shrink-on solder sleeve to make the Pin 6 shield connection
- ❑ 060 Assemble the backshell to the connector, connect it to the port, and secure all wiring.

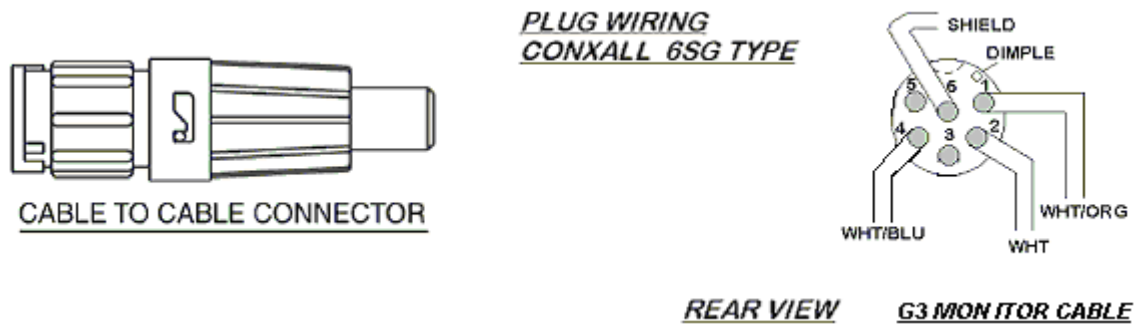

Figure B- 14: Download Port Connector to GEN III Monitor – ADAS+

For ADAS+ Upgrade Monitors Only:

INSTALLATION CAUTION:

⇒ *The connections to the Download Port cables (DL PORT and G3 MONITOR) for the ADAS+ Upgrade use a single pin connector (6PG type).*

- ❑ 010 Trim the DL PORT “AAB49B24” and the G3 MONITOR “AAB48C24” connector cable connector cable to length, and slide the 6PG type ConXall™ connector backshell parts onto the cable. This connector will connect to the supplied harness ConXall™ connector.
- ❑ 020 Refer to the illustration Figure B- 15 and connect the cable to the included ConXall™ connector using the socket configuration shown. Splice a short wire lead to the cable shields on both the DL PORT “AAB49B24” and G3 MONITOR “AAB28C24” cables with a shrink-on solder sleeve to make the Pin 6 shield connection.
- ❑ 030 Assemble the backshell to the connector, connect it to the lamp, and secure all wiring.

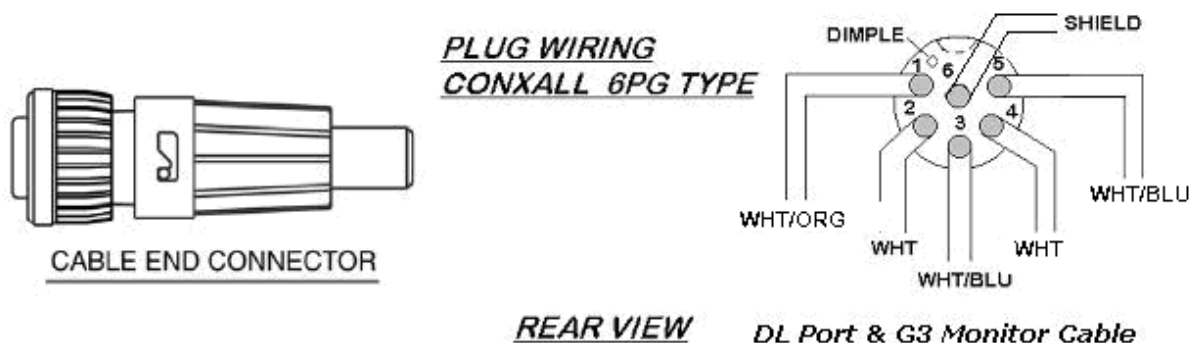

Figure B- 15: Download Port Connector to GEN III Monitor – ADAS+ Upgrade

4.2 Airframe Sensors

4.2.1 On Ground (Weight-on-Wheels) Signal

For All Gen III Monitors (except ADAS^d and Cessna Models):

INSTALLATION CAUTION:

- ⇒ The “ON GROUND SW” cable is a single conductor shielded wire. Care must be taken to strip back and secure shield to prevent possible shorting to the signal wire. Use plastic spiral wrap where necessary to prevent chaffing and abrasion.
- ⇒ Weight on Wheels (WOW) is a secondary hardware lockout preventing the DTU from transmitting in flight. The sensor requires an electrical ground, signaling that the aircraft is not in flight.
- ⇒ The “ON GROUND SW” cable uses a diode to protect the WOW circuit if the cable is shorted to ground. This diode must be installed per the installation instructions and wiring diagram.

- ❑ 010 Trim the ON GROUND SW “AAD09A24” cable to length.
- ❑ 020 Splice the 1N4001 (300-00034) diode to the ON GROUND SW “AAD09A24” cable. Refer to Figure B- 16 for the correct orientation of the diode. The diode must be located as close as possible to the WOW connection point.
- ❑ 030 Splice to the Weight-on-Wheels connection. Refer to Section 5.2 for the applicable WOW connection

<u>Color</u>	<u>Aircraft On Ground Signal</u>
WHT	“WOW” Switch

- ❑ 040 Secure all wiring.

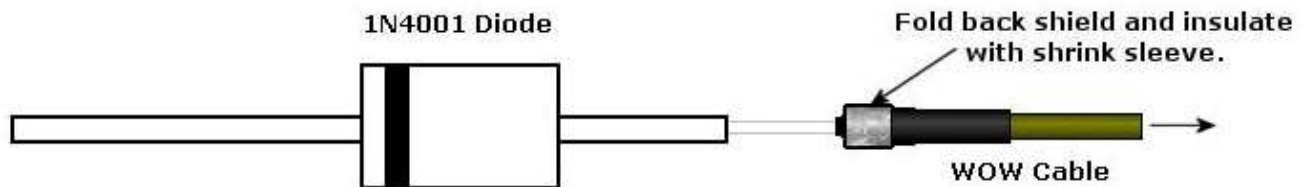

Figure B- 16: WOW Diode Orientation

4.3 Electrical Power

4.3.1 Battery Power / Ground Connection

For All Gen III Monitors (except ADAS^d):

INSTALLATION CAUTION:

⇒ Power to the DTU must be available any time DC power is applied to the aircraft.

- ❑ 010 Following the illustration (Figure B- 17) connect the AC BATTERY “AAV09B24” white (positive) wire to supplied fuse holder. Connect to the aircraft battery so that DC power is available at all times to the processor. Refer to Section 5.2 for the applicable power connection.
- ❑ 020 Following the illustration (Figure B- 17) connect the AC BATTERY “AAV09B24” white/blue (negative) wire to aircraft ground.

INSTALLATION CAUTION:

- ⇒ Ensure that any connection to aircraft power incorporates a minimal wire length from the power source to the protection device, fuse or breaker. Recommended length is six (6) inches or less.
- ⇒ Ensure that the wire is protected from shorting out against the airframe or any other sharp objects.

<u>Color</u>	<u>Aircraft Power Source</u>
WHT	Aircraft Battery +
WHT/BLU	Aircraft Ground –

- ❑ 030 Secure all wiring.

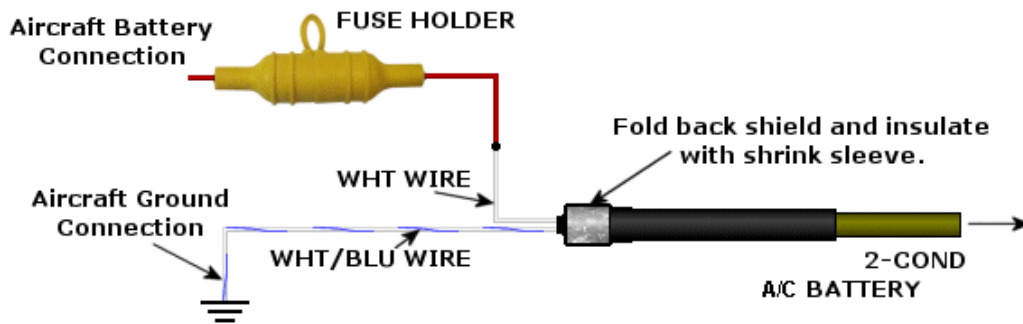

Figure B- 17: Aircraft Battery Final Wiring

4.3.2 Bus (Switched) Power Connection

For All Gen III Monitors (except ADAS^d):

INSTALLATION CAUTION:

- ⇒ *Ensure that any connection to aircraft power incorporates a minimal wire length from the power source to the protection device, fuse or breaker. Recommended length is six (6) inches or less.*
 - ⇒ *Ensure that the wire is protected from shorting out against the airframe or any other sharp objects.*
- ❑ 010 Following the illustrations (Figure B- 18) connect the AC BUS “AAV19A24” wire to supplied fuse holder. Connect to aircraft bus (switched) power. Refer to Section 5.2 for the applicable power connection
 - ❑ 020 Secure all wiring.

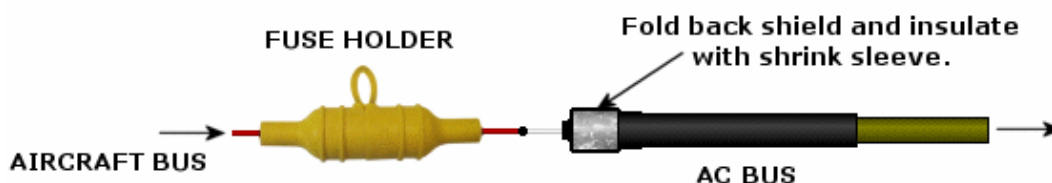

Figure B- 18: Aircraft Bus Final Wiring

4.4 Final Installation Notes

For ADAS+ Monitors Only:

- ❑ 010 Connect the cable from the DTU marked DL PORT “AAB49B24” to the existing Download Port ConXall™ connector that is mounted in the aircraft.
- ❑ 020 Connect the G3 MONITOR “AAB48C24” cable to the existing Download Port cable (from the GEN III processor) at the ConXall™ connector.
- ❑ 030 Connect the DTU STATUS LAMP “AAV39D24” connector to the DTU status lamp.
- ❑ 040 Route and secure all wires making sure engine / aircraft control movements will not be affected by the DTU wiring. Properly dress any splices and shield terminations. Make sure wire harnesses will not come in contact with sharp sections of the aircraft.
- ❑ 050 Install all aircraft panels.
- ❑ 060 Record the location of the processor, GSM antenna, and the DTU Status Lamp in the Installation Summary Table provide in Instructions for Continued Airworthiness, DTU-G-260-1/B, Section 7.1

For ADAS+ Upgrade Monitors Only:

- 010 Disconnect the cable to the COMM port on the ADAS+ Upgrade processor.
- 020 Connect P1 of the supplied harness (TWIN-C080-1) to the COMM port on the ADAS+ Upgrade processor
- 030 Connect J1 of the supplied harness (TWIN-C-080-1) to the COMM cable that was removed in Step 020.
- 040 Connect the ConXall™ connector on the supplied harness (TWIN-C-080-1) to the ConXall™ connector from the DTU processor.
- 050 Connect the DTU “STATUS LAMP” connector to the DTU status lamp.
- 060 Route and secure all wires making sure engine / aircraft control movements will not be affected by the DTU wiring. Properly dress any splices and shield terminations. Make sure wire harnesses will not come in contact with sharp sections of the aircraft.
- 070 Install all aircraft panels.
- 080 Record the location of the processor, GSM antenna, and the DTU Status Lamp in the Installation Summary Table provide in Instructions for Continued Airworthiness, DTU-G-260-1/B, Section 7.1

5 HARNESS CONNECTOR SIGNAL PINOUTS

5.1 ACS Cable J1, 37 Pin “A” Keyed Connector

INSTALLATION CAUTION:

- ⇒ *Before making any wiring connections, verify all connection locations with the aircraft manufacturer’s wiring diagram manuals.*
- ⇒ *Perform a continuity check on all wires before final connection.*
- ⇒ *Route all harnesses along existing harnesses wherever possible.*
- ⇒ *Cables may be marked with shrink-on labels near the terminal end. When you shorten a cable behind a label, be sure to re-label it.*

For ADAS^d Monitors Only:

Connector Pin	Harness Wire Color	Signal Name	Wired To
---------------	--------------------	-------------	----------

5 COND CABLE

J1-1	WHT	28V BUS	10 Pin Male Connector (Pin 9)
J1-36	WHT/ORG	28V AUX	10 Pin Male Connector (Pin 6)
J1-4	WHT/GRN	28V BAT	10 Pin Male Connector (Pin 5)
J1-32	WHT/RED	RUN/CONF	10 Pin Male Connector (Pin 4)
J1-2	WHT/BLU	28V RTN	10 Pin Male Connector (Pin 3)

2 COND CABLE

J1-6, 8	WHT/BLU	RS485A (-)	10 Pin Male Connector (Pin 2)
J1-5, 7	WHT	RS485B (+)	10 Pin Male Connector (Pin 1)

2 COND CABLE

Shield	Shield	Shield	10 Pin Female Connector (Pin 5)
J1-16, 19	WHT/BLU	RS485A (-)	10 Pin Female Connector (Pin 2)
J1-18, 17	WHT	RS485B (+)	10 Pin Female Connector (Pin 1)

5 COND CABLE

Shield	Shield	Shield	6 Pin Female Connector (Pin 6)
J1-34	WHT/ORG	LAMP 2	6 Pin Female Connector (Pin 5)
J1-34	WHT/RED	SWITCH	6 Pin Female Connector (Pin 4)
J1-37	WHT/GRN	LAMP 1	6 Pin Female Connector (Pin 3)
J1-2	WHT/BLU	GROUND	6 Pin Female Connector (Pin 2)
J1-1	WHT	LAMP PWR	6 Pin Female Connector (Pin 1)

1 COND CABLE

J1-15	WHT	On-Ground Sw	Aircraft Ground
-------	-----	--------------	-----------------

Note: All shields are terminated to the backshell.

For ADAS+ Monitors Only:

Connector Pin	Harness Wire Color	Signal Name	Wired To
3 COND CABLE			
J1-5, 7	WHT/ORG	ACS1- RS485B (+)	Download Port Pin-1
J1-6, 8	WHT	ACS1- RS485A (-)	Download Port Pin-2
J1-32	WHT/BLU	RUN/CONF	Download Port Pin-4
4 COND CABLE			
J1-23	WHT/GRN	DIAG SWITCH	Status Lamp Pin-4
J1-34	WHT	INDIC SW LAMP 2	Status Lamp Pin-5
J1-37	WHT/ORG	INDIC SW LAMP 1	Status Lamp Pin-3
J1-2	WHT/BLU	GROUND	Status Lamp Pin-2
1 COND CABLE			
J1-1	WHT	LAMP POWER	Status Lamp Pin-1
2 COND CABLE			
J1-19, 16	WHT	RS485A (-)	Conn Download Port Pin-2
J1-18, 17	WHT/BLU	RS485B (+)	Conn Download Port Pin-1
2 COND CABLE			
J1-4	WHT	Aircraft Battery Power +	A/C Battery Positive
J1-3	WHT/BLU	Aircraft Ground -	A/C Battery Ground
1 COND CABLE			
J1-1	WHT	Aircraft Bus Power +	A/C Switched Power
1 COND CABLE (Except Cessna Caravan)			
J1-15	WHT	On-Ground Sw	Aircraft Weight-on-Wheels
1 COND CABLE (Cessna Caravan Only)			
J1-15	WHT	On-Ground Sw	Aircraft Ground

Note: All shields are terminated to the backshell.

For ADAS+ Upgrade Monitors Only:

Connector Pin	Harness Wire Color	Signal Name	Wired To
3 COND CABLE			
J1-5, 7	WHT/ORG	ACS1-RS485B (+)	Download Port Pin-1
J1-6, 8	WHT	ACS1-RS485A (-)	Download Port Pin-2
J1-32	WHT/BLU	RUN/CONF	Download Port Pin-3
4 COND CABLE			
J1-23	WHT/GRN	DIAG SWITCH	Status Lamp Pin-4
J1-34	WHT	INDIC SW LAMP 2	Status Lamp Pin-5
J1-37	WHT/ORG	INDIC SW LAMP 1	Status Lamp Pin-3
J1-2	WHT/BLU	GROUND	Status Lamp Pin-2
1 COND CABLE			
J1-1	WHT	LAMP POWER	Status Lamp Pin-1
2 COND CABLE			
J1-19, 16	WHT	RS485A (-)	Download Port Pin-4
J1-18, 17	WHT/BLU	RS485B (+)	Download Port Pin-5
2 COND CABLE			
J1-4	WHT	Aircraft Battery Power +	A/C Battery Positive
J1-3	WHT/BLU	Aircraft Ground -	A/C Battery Ground
1 COND CABLE			
J1-1	WHT	Aircraft Bus Power +	A/C Switched Power
1 COND CABLE			
J1-15	WHT	Aircraft Weight-On-Wheels	Aircraft Weight-on-Wheels

Note: All shields are terminated to the backshell.

5.2 DTU Connection Chart – Power and RF Lockout

For All Gen III Monitors (except ADAS^d):

5.2.1 Cessna Caravan Model 208 Series

Sensor	Connection Chart		
	<i>Wire Number</i>	<i>Aircraft Component</i>	<i>DTU Connector</i>
A/C Bus	AAV19A24	<i>Relay K 3</i>	<i>J1</i>
		A1	Pin 1 WHT
A/C Battery	AAV09B24	<i>Relay K 3</i>	<i>J1</i>
		A2	Pin 4 WHT
		Ground	Pin 3 WHT/BLU
Aircraft Ground	AAD09A24	<i>Aircraft Ground</i>	<i>J1</i>
		Aircraft Ground	Pin 15 WHT

Table B- 1: DTU Connection Chart Cessna Caravan Model 208 Series

5.2.2 Raytheon Model C90

Sensor	Connection Chart		
	<i>Wire Number</i>	<i>Aircraft Component</i>	<i>DTU Connector</i>
A/C Bus	AAV19A24	<i>Main Bus</i>	<i>J1</i>
		Supplied Circuit Breaker	Pin 1 WHT
A/C Battery	AAV09B24	<i>Battery</i>	<i>J1</i>
		A228 Box Assy. – Bat Bus	Pin 4 WHT
		Aircraft Ground	Pin 3 WHT/BLU
WOW	AAD09A24	<i>WOW Cockpit Control</i>	<i>J1</i>
		J125 – Pin 2	Pin 15 WHT

Table B- 2: DTU Connection Chart Raytheon Model C90

5.2.3 Raytheon Models 200 & 200T

Sensor	Connection Chart		
	<i>Wire Number</i>	<i>Aircraft Component</i>	<i>DTU Connector</i>
A/C Bus	AAV19A24	<i>Main Bus</i>	<i>J1</i>
		Supplied Circuit Breaker	Pin 1 WHT
A/C Battery	AAV09B24	<i>Battery</i>	<i>J1</i>
		W103 Bus Bar Panel Assy.	Pin 4 WHT
		Aircraft Ground	Pin 3 WHT/BLU
WOW	AAD09A24	<i>WOW Cockpit Control</i>	<i>J1</i>
		A100 – Pin 1	Pin 15 WHT

Table B- 3: DTU Connection Chart Raytheon Model 200 & 200T

5.2.4 Raytheon Models 200CT, A200, A200C, & A200CT

Sensor	Connection Chart		
	<i>Wire Number</i>	<i>Aircraft Component</i>	<i>DTU Connector</i>
A/C Bus	AAV19A24	Main Bus	J1
		Supplied Circuit Breaker	Pin 1 WHT
A/C Battery	AAV09B24	Battery	J1
		W103 A228 Panel Assy. - Battery Bus Power	Pin 4 WHT
		Aircraft Ground	Pin 3 WHT/BLU
WOW	AAD09A24	WOW Cockpit Control	J1
		A100 – Pin 1	Pin 15 WHT

Table B- 4: DTU Connection Chart Raytheon Model 200CT, A200, A200C, & A200CT

5.2.5 Raytheon Models B200C, B200CT, B200, B200T

Sensor	Connection Chart		
	<i>Wire Number</i>	<i>Aircraft Component</i>	<i>DTU Connector</i>
A/C Bus	AAV19A24	Main Bus	J1
		Supplied Circuit Breaker	Pin 1 WHT
A/C Battery	AAV09B24	Battery	J1
		W103 A228 Panel Assy.- Battery Bus Power	Pin 4 WHT
		Aircraft Ground	Pin 3 WHT/BLU
WOW	AAD09A24	WOW Cockpit Control	J1
		A100 – Pin 1	Pin 15 WHT

Table B- 5: DTU Connection Chart Raytheon Model B200C, B200CT, B200, & B200T

5.2.6 Raytheon Model 300 Series

Sensor	Connection Chart		
	<i>Wire Number</i>	<i>Aircraft Component</i>	<i>DTU Connector</i>
A/C Bus	AAV19A24	Main Bus	J1
		Supplied Circuit Breaker	Pin 1 WHT
A/C Battery	AAV09B24	Battery	J1
		W1 A1 Circuit Breaker Box Assy.	Pin 4 WHT
		Aircraft Ground	Pin 3 WHT/BLU
WOW	AAD09A24	WOW Cockpit Control	J1
		A100 – Pin 1	Pin 15 WHT

Table B- 6: DTU Connection Chart Raytheon Model 300 Series

5.2.7 Raytheon Model B300 Series

Sensor	Connection Chart		
	<i>Wire Number</i>	<i>Aircraft Component</i>	<i>DTU Connector</i>
A/C Bus	AAV19A24	Main Bus	J1
		Supplied Circuit Breaker	Pin 1 WHT
A/C Battery	AAV09B24	Battery	J1
		W1 A1 Circuit Breaker Box Assy.	Pin 4 WHT
		Aircraft Ground	Pin 3 WHT/BLU
WOW	AAD09A24	WOW Cockpit Control	J1
		A100 – Pin 1	Pin 15 WHT

Table B- 7: DTU Connection Chart Raytheon Model B300 Series

5.2.8 Raytheon Model 1900 & 1900C

Sensor	Connection Chart		
	<i>Wire Number</i>	<i>Aircraft Component</i>	<i>DTU Connector</i>
A/C Bus	AAV19A24	Main Bus	J1
		Supplied Circuit Breaker	Pin 1 WHT
A/C Battery	AAV09B24	Battery	J1
		W214 Bus Bar-Hot Battery	Pin 4 WHT
		Aircraft Ground	Pin 3 WHT/BLU
WOW	AAD09A24	WOW Cockpit Control	J1
		J125 – Pin 2	Pin 15 WHT

Table B- 8: DTU Connection Chart Raytheon Model 1900 & 1900C

5.2.9 Raytheon Model 1900D

Sensor	Connection Chart		
	<i>Wire Number</i>	<i>Aircraft Component</i>	<i>DTU Connector</i>
A/C Bus	AAV19A24	Main Bus	J1
		Supplied Circuit Breaker	Pin 1 WHT
A/C Battery	AAV09B24	Battery	J1
		P202 Pin 11 or 12	Pin 4 WHT
		Aircraft Ground	Pin 3 WHT/BLU
WOW	AAD09A24	WOW Cockpit Control	J1
		J542 – Pin M	Pin 15 WHT

Table B- 9: DTU Connection Chart Raytheon Model 1900D Series

6 WIRING DIAGRAM

6.1 DTU / ADAS^d Interconnect Schematic

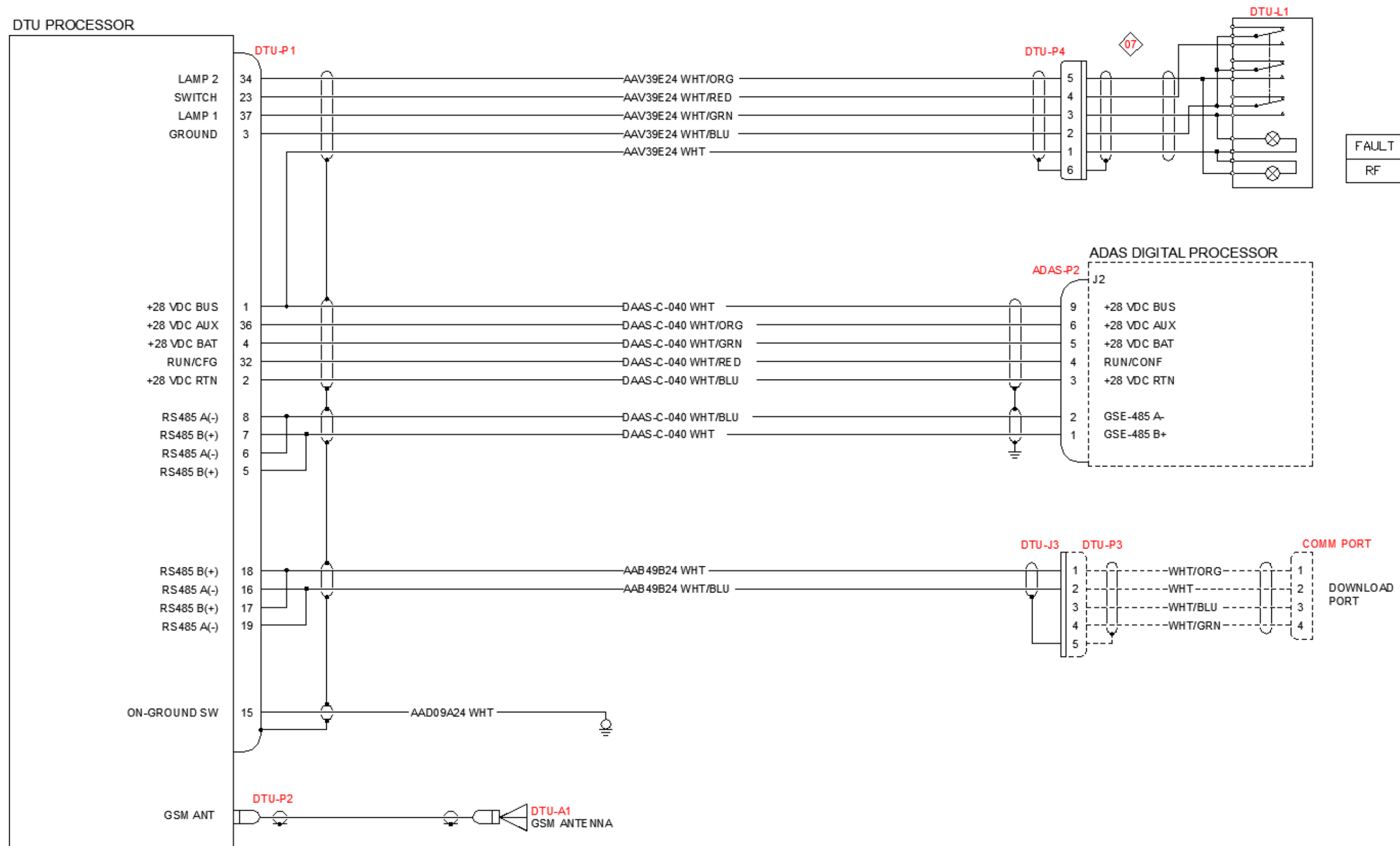

Figure B- 19: DTU / ADAS^d Wiring Schematic

This Document is Subject to the Restrictions Contained on Cover Page
The export control classification with respect to this document is contained on the first page

6.2 DTU / ADAS+ Interconnect Schematic (Except Cessna Caravan)

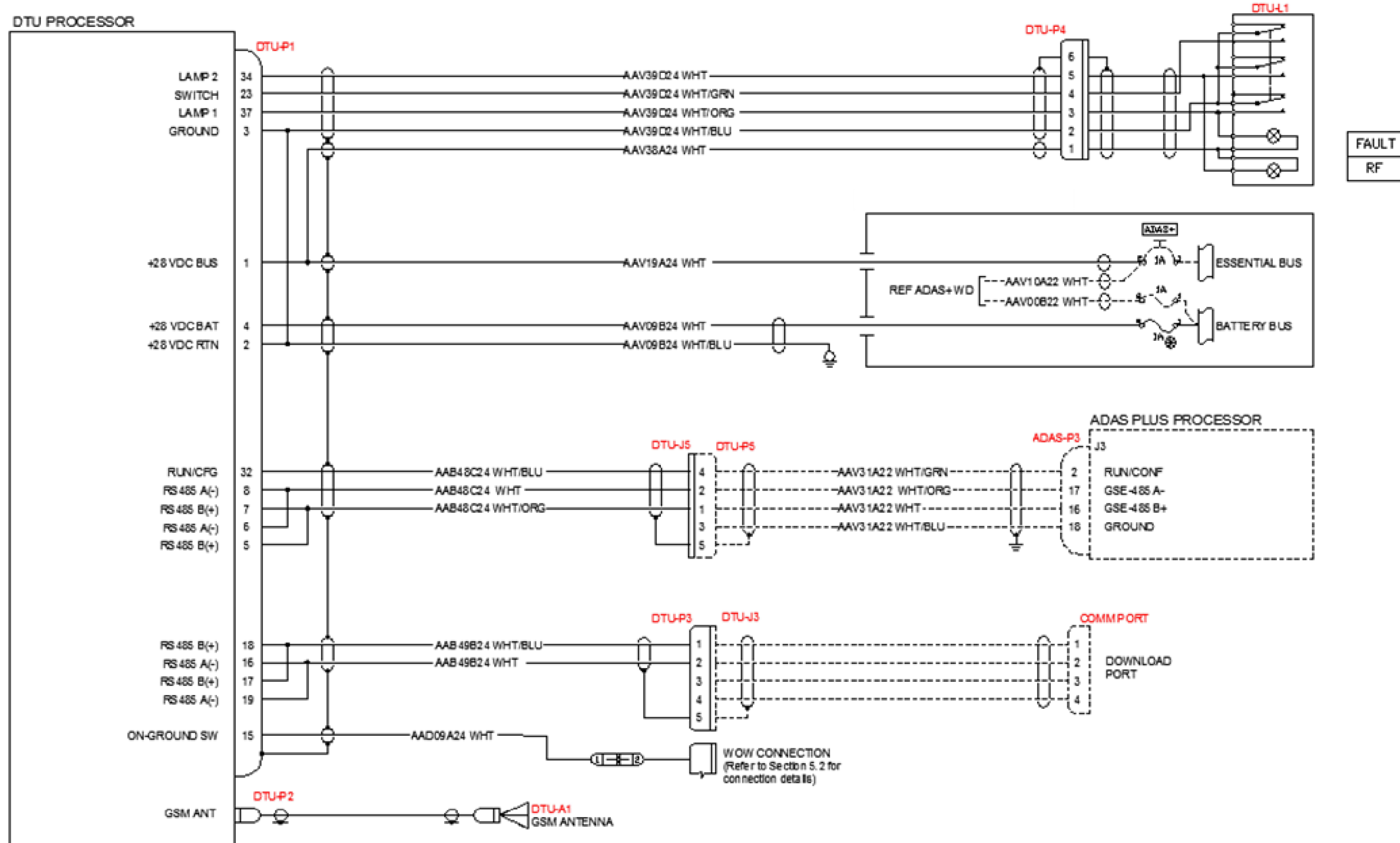

Figure B- 20: DTU / ADAS+ Wiring Schematic (Except Cessna Caravan)

6.3 DTU / ADAS+ Interconnect Schematic (Cessna Caravan STC Installation)

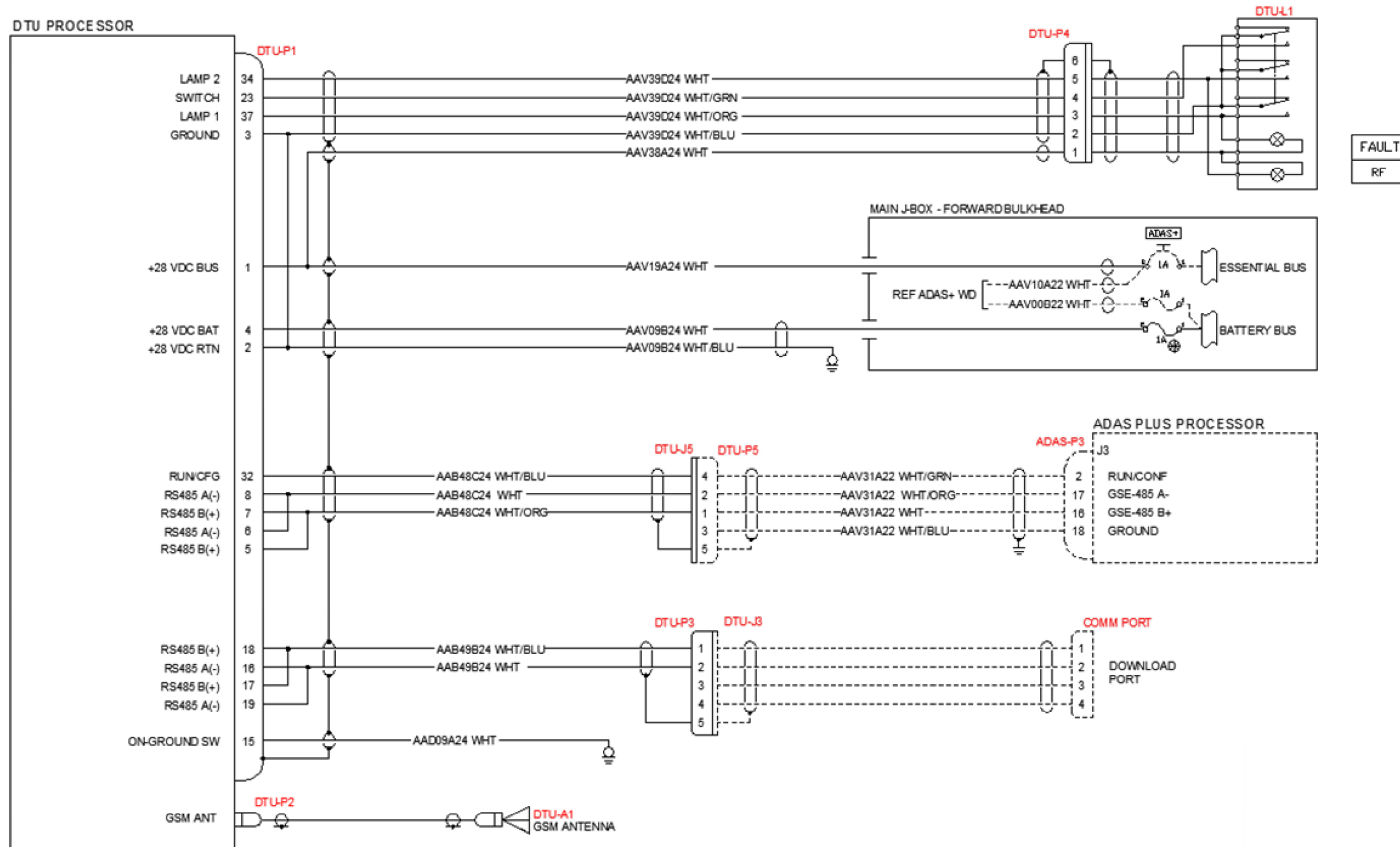

Figure B- 21: DTU / ADAS+ Wiring Schematic (Cessna Caravan STC Installation)

This Document is Subject to the Restrictions Contained on Cover Page
The export control classification with respect to this document is contained on the first page

6.4 DTU / ADAS+ Interconnect Schematic (Cessna Caravan Factory Installation)

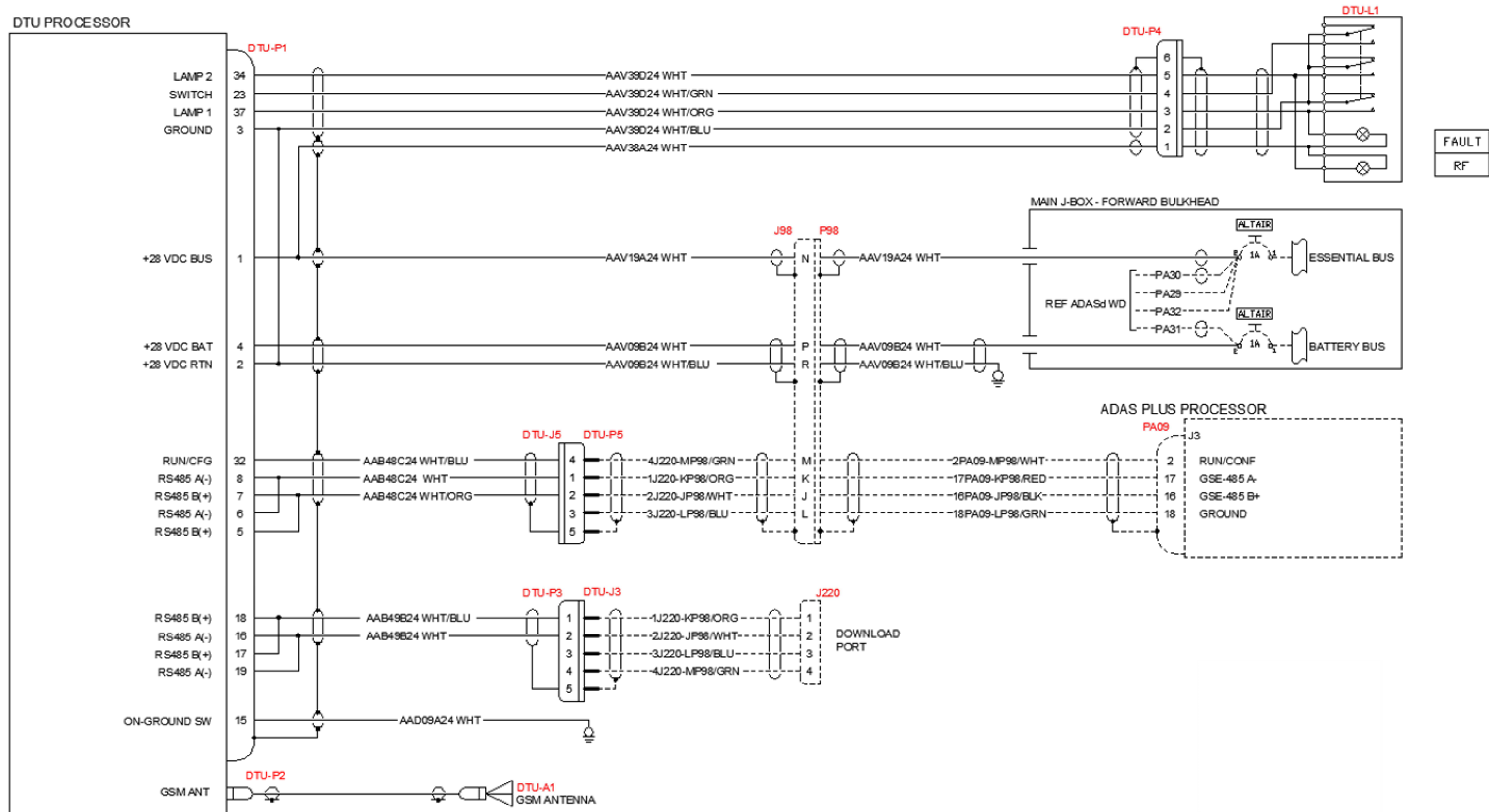

Figure B- 22: DTU / ADAS+ Wiring Schematic (Cessna Caravan Factory Installation)

6.5 DTU / ADAS+ Upgrade Interconnect Schematic

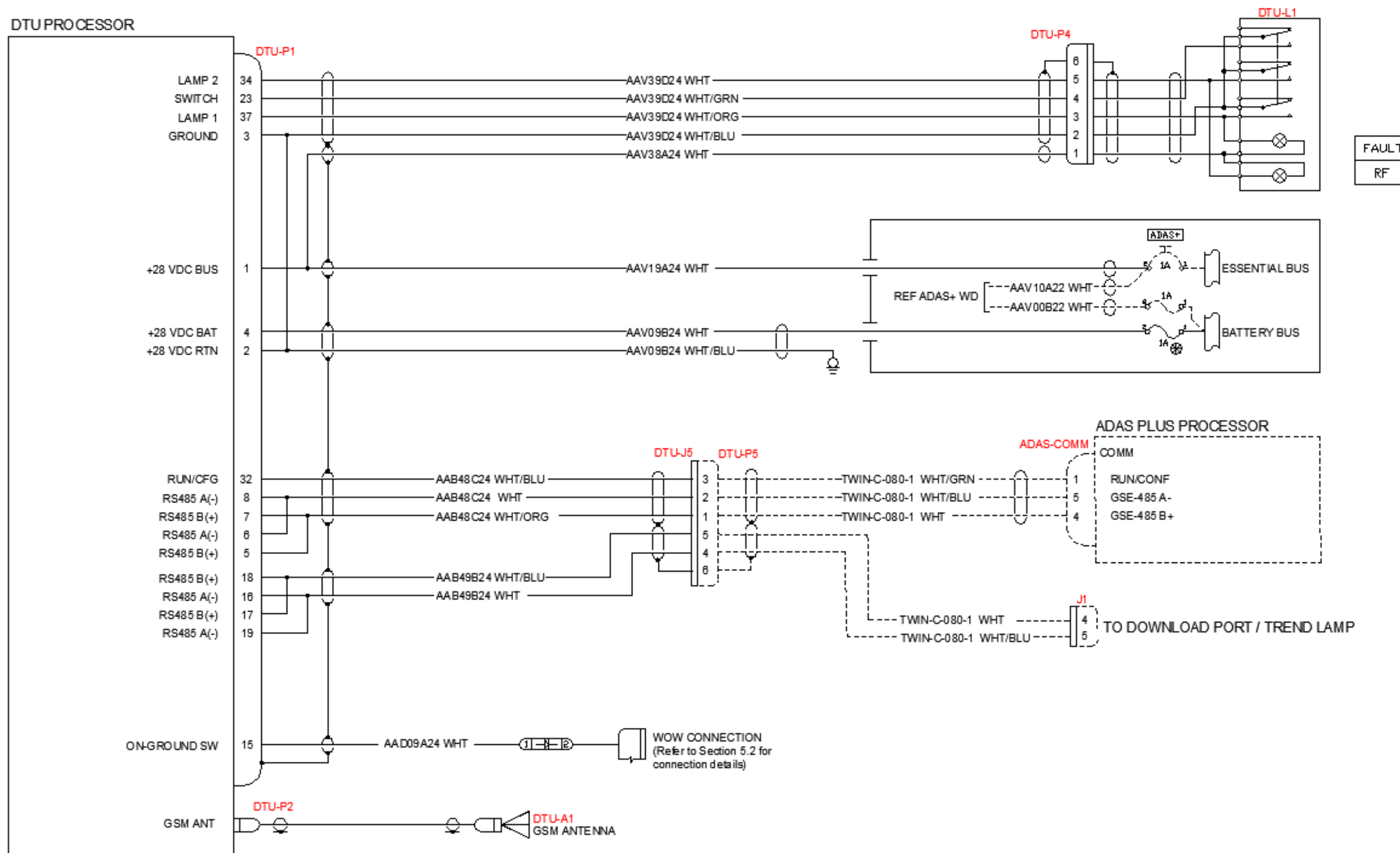

Figure B- 23: DTU / ADAS+ Upgrade Wiring Schematic