

1

2

3

4

- NOTES:
1. AIRCRAFT GRADE MATERIAL, 2024-T3 (AMS-QQ-A-250/5) TO BE USED UNLESS SPECIFIED.
 2. OBSERVE MINIMUM FASTENER EDGE DISTANCE OF 2D, MINIMUM FASTENER PITCH OF 4D, AND MINIMUM BEND RADIUS OF 3T IAW FAA AC43.13, LATEST REVISION.
 3. ALL BARE SURFACE METAL IS TO UNDERGO PROTECTIVE TREATMENT AND CORROSION PREVENTION IAW SRM 51-20-00.
 4. FASTENERS CAN BE SUBSTITUTED WITH ALTERNATIVE AIRCRAFT GRADE FASTENERS OF EQUIVALENT SPECIFICATION LISTED ON SRM 51-40-00.
 5. DEBUR ALL SHARP EDGES AND HOLES.

QTY	REQD	CAGE CODE	PART OR IDENTIFYING NO.	NOMENCLATURE OR DESCRIPTION	MATERIAL SPECIFICATION	FIND NO.
1			FAST-C-073-2	GSM ANTENNA CABLE		04
2			990-00079	VELCRO (STRIP)		03
1			DTU-D-094-1	GSM ANTENNA		02
	<input checked="" type="checkbox"/>		FAST-A-091-1	ANTENNA INSTALLATION		01

Letter	Description	Date	App'd
A	PRODUCTION RELEASE	12/19/11	SC
B	REVISE PER ECD#1150	2/20/13	JMM

DRAWING REVISIONS	

TOLERANCES	
A/B	±0.032
0.X	±0.015
0.XX	±0.010
0.XXX	±0.005
0.XXXX	±0.0005
Angle	±0.5°
Finish	63
Unless Otherwise Specified	

Part Name	Part No.	Material
ANTENNA INSTALLATION	FAST-A-091-1	

File Name	Part No.	Rev
FAST-A-091-1.DWG	FAST-A-091-1	B

Part Name	Part No.	Rev
ANTENNA INSTALLATION	FAST-A-091-1	B

1

2

3

4

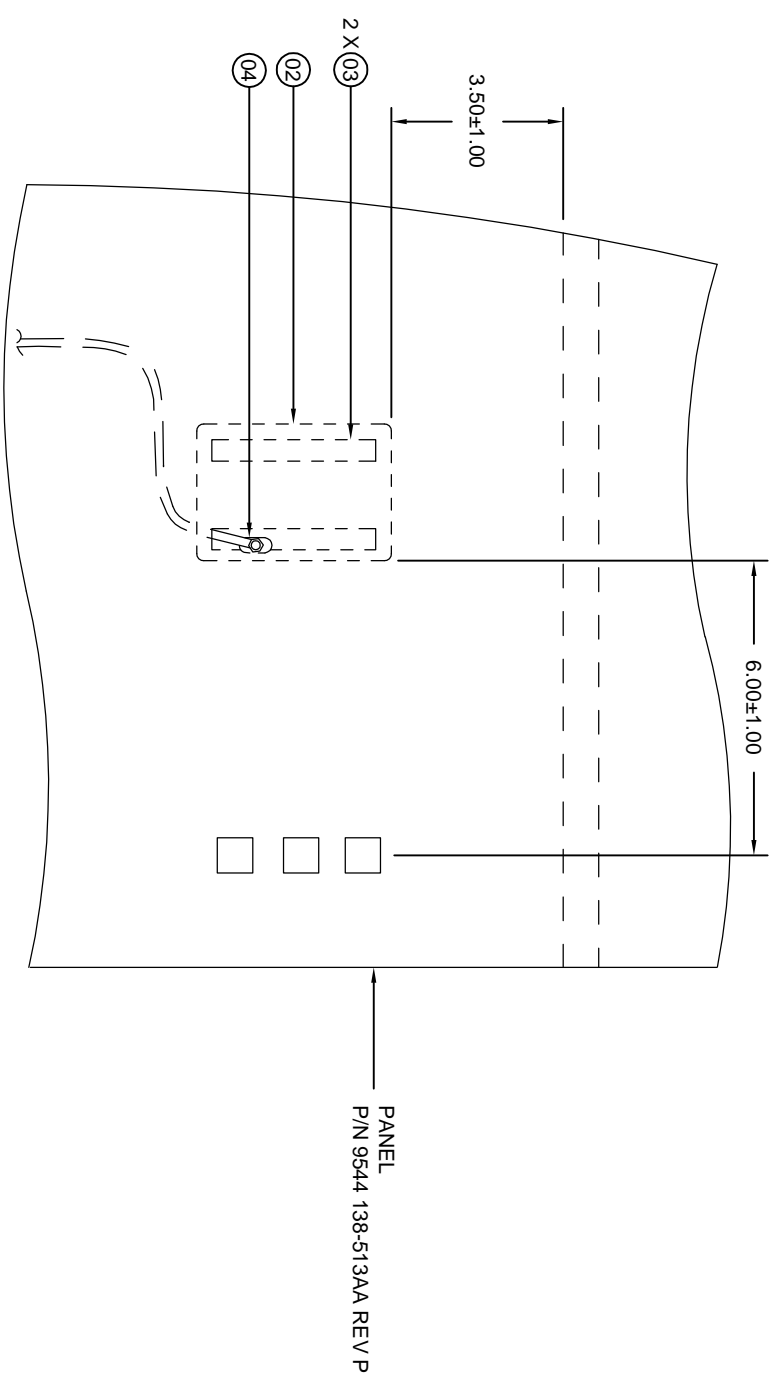
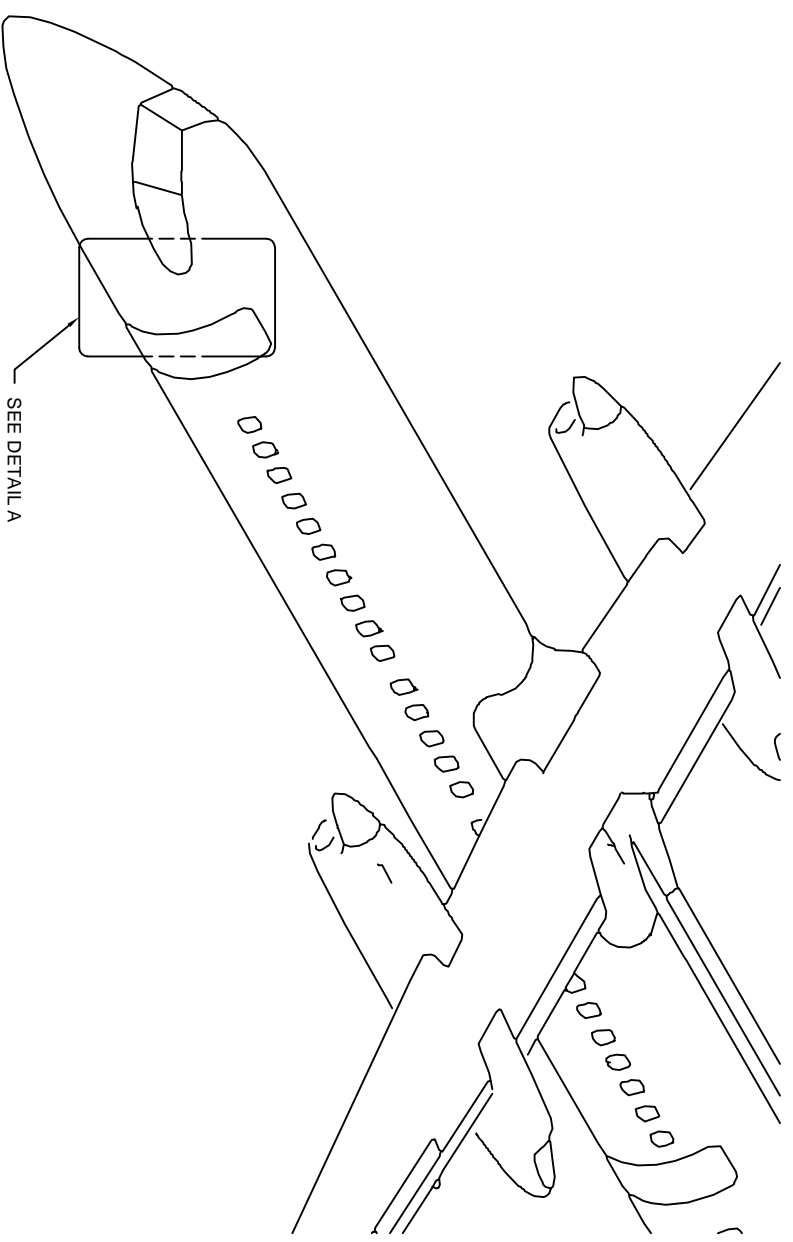

DETAIL **A**
 SCALE: 1/4
 (VIEW LKG FWD)

UP
 LHS

Part Name		ANTENNA INSTALLATION	
Scale		B	
Size		B	
SHEET		2 OF 2	
ECCN: 9E991		File Name FAST-A-091-1.DWG	
Part No. FAST-A-091-1		Part No. FAST-A-091-1	
Rev A		Rev A	



1 2 3 4

1

2

3

4