

Introduction

Thanks for purchasing PHS-6 Bluetooth Headset. Your Bluetooth Headset is a stylish headset that enables comfortable handsfree communication with compatible phone that supports Bluetooth technology.

Functions & Controls

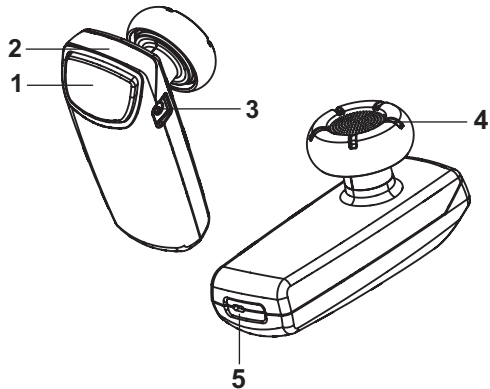

1. Multifunction key

- Switches the headset on and off
- Answer incoming call
- End active call
- Reject incoming call by long pressing button

2. Indicator Light

3. Charger connector For battery charging.

4. Earpiece Relays the caller's voice.

5. Microphone Picks up your voice input.

Getting started

Remove all components from the package...
Bluetooth Headset (with 15 mm diameter earbud)
AC Battery Charger
User Guide
An extra earbud (18 mm diameter)

Charging the battery

Before using the Bluetooth Headset, you need to charge the built-in rechargeable battery for approximately 2 hours. When the battery is fully charged, it provides up to 6 hours talking time and up to 150 hours standby time.

1. Connect the AC battery charger cable's jack to Bluetooth Headset's socket.

2. Plug the charger's AC plug to AC outlet. When charging, the Bluetooth Headset's status indicator lights in solid green.

3. When the battery is fully charged, the status indicator turns off. Unplug the charger cable from AC outlet and Bluetooth Headset.

Pairing the Bluetooth headset to a Bluetooth mobile phone

Pairing is the process for linking the headset with your Bluetooth enabled mobile phone. After this process is completed, you can use the Bluetooth Headset with the paired mobile phone. The Bluetooth Headset can be paired with up to 8 compatible phones but connected to only one phone at a time.

1. The headset must be in off mode.
2. Press the button for at least 6 seconds. The LED light flashing rapidly, and two high tones can be heard. Your mobile phone can now "look for" the headset.
3. Activate the Bluetooth connection with the mobile phone according to the mobile phone's user's guide.
4. Set the mobile phone to search for the Bluetooth devices according to the mobile phone's user's guide.
5. Select the Bluetooth Headset from the phone menu.
6. Enter the pin code 0000 to connect (or "pair") Bluetooth Headset to the phone. You will hear two high tones when pairing completed.
7. Select PHS-6 from the device list on your phone. The LED will light twice rapidly every 5 seconds with the headset connected to your phone.

If the headset is turned on within 10 meters from several paired phones, the headset will try to connect to the last connected phone within 10 seconds. If the headset does not connect to the last connected phone (for example, the paired phone is turned off or it rejects the connection), the LED will be flashing every 2.5 seconds indicating it is in power on however not engaged status.

Place the headset over your ear

The headset is ready to wear on either ear. You can plug the earpiece into your ear and point the headset toward your mouth.

The headset comes with a 15 mm earbud by default. For a better fit on your ear, the headset is provided with an extra larger earbud (18 mm). You can use the larger one if necessary.

Hardware reset

Plug in power connector (DC jack). Please notice that pairing information will NOT be erased.

Operation

To turn on the headset

Press the multi-function key for about 2 seconds. The LED lights in solid green for 1 second. 4 ascending tones can be heard.

To turn off the headset

Press the multi-function key for about 4 seconds. The LED lights in solid green for 1 second. 4 descending tones can be heard.

Making a Phone Call

When the headset is connected to the phone, make a call using the phone in the normal way.

Note: the call functions depending on the phone type you use. Please refer to the manual of your phone for the related function.

Answering and Ending a Phone Call

When a call comes in, the LED will flash twice briefly every second, and ringing tones can be heard through the headset until the call is answered.

Press the multi-function key briefly to answer the call. Press the multi-function key briefly to end an active call.

You can also answer and end the call through the mobile phone.

Note: Some phones offer Auto Answer function and may be used with the headset or speakerphone, but this is a phone dependent feature. Please refer to the manual of your phone for that function.

Rejecting a Call

When you receive an incoming call that you do not want to answer, press the multi-function key for more than 2 seconds.

Redialing the Last Dialed Number (Phone dependent)

Double press the multi-function key for when no call is in progress. A high tone can be heard.

Switching the Call between Phone and Headset

Press the multi-function key for 2 seconds or use the respective function in your phone. A high tone can be heard.

Voice dialing (phone dependent)

Press the multi-function key briefly when there is no call in active to initial voice dialing, and one high tone can be heard. To terminate voice dialing, press the multi-function key briefly again.

Reconnecting the Paired Bluetooth Headset to a Compatible Phone

To reconnect the Bluetooth Headset to the last connected phone, proceed as follows:

1. Press and hold the multi-function key for 4 seconds to turn on the Bluetooth Headset.
2. Make sure your phone is on and Bluetooth function is enabled. Please refer to the phone's user guide and make the connection in the Bluetooth menu of your phone.
3. The phone should connect to the headset automatically. If not, please refer to 'Pairing the Bluetooth Headset with a Compatible Phone' section and performance pairing again,

Note: If the headset is away from the connected phone for more than 10 meters, the headset will be disconnected from the phone, and will perform reconnecting procedure automatically within 10 minutes.

Other status

Status	LED	Sound
Idle* (power on but not connected)	Flashing once every 2.5 seconds	n/a
Battery low	Double brief flashing every 2.5 seconds	A low beep every 5 seconds
Charging	Solid light	n/a
Call in active	Double brief flashing every 5 seconds	n/a

* The headset will switch off automatically if in idle mode for 30 minutes.

FCC/Industry Canada notice

This device complies with Part 15 of the FCC Rules. Operation is subject to the following two conditions: 1. This device may not cause harmful interference; and 2. This device must accept any interference received, including interference that may cause undesired operation. This equipment has been tested and found to comply with the limits for a Class B digital device, pursuant to Part 15 of the FCC Rules.

These limits are designed to provide reasonable protection against harmful interference in a residential installation. This equipment generates, uses and can radiate radio frequency energy and, if not installed and used in accordance with the instructions, may cause harmful interference to radio communications. However, there is no guarantee that interference will not occur in a particular installation. If this equipment does cause harmful interference to radio or television reception, which can be determined by turning the equipment off and on, the user is encouraged to try to correct the interference by one or more of the following measures: Reorient or relocate the receiving antenna. Increase the separation between the equipment and receiver. Connect the equipment into an outlet on a circuit different from that to which the receiver is connected. Consult the dealer or an experienced radio/TV technician for help. NOTE: FCC Radiation Exposure Statement: This equipment complies with FCC radiation exposure limits set forth for an uncontrolled environment. This transmitter must not be co-located or operating in conjunction with any other antenna or transmitter. NOTE: Modifications not expressly approved by PRIMAX could void the user's authority to operate the equipment.