



Manual

of Carrier Controller

Prodrive Technologies B.V.

Reference: SPD6752150121R17.docx
Reference date: 2019-01-23
Author(s): Guido Beyer, Willem van Helmond
Status: Concept

Confidential

Template PN: 6001-1244-6904
Template date: 2016-07-26

Prodrive Technologies

PO Box 28030
NL - 5602 JA Eindhoven

Science Park Eindhoven 5501
NL - 5692 EM Son

prodrive-technologies.com

T. +31 40 26 76 200
F. +31 40 26 76 201

The contents of this document are confidential information and intellectual property of Prodrive Technologies. Nothing of this document may be used or duplicated or published without prior written approval of Prodrive Technologies.

Document history

Rel.	Date	Status	Changes
R01	2016-12-12	Concept	Initial release manual for internal review.
R02	2016-12-14	Accepted	Updates after internal review, version released for CE approval
R03	2016-12-15	Accepted	Changed short circuit rating to 5kA, added IP54 note for connectors
R04	2016-12-21	Accepted	Removed RCD requirements, PE already ensures protection.
R05	2016-12-29	Accepted	Added LED, added capacitor reforming, added disposal section, added 3 conditions of use (first two and last two)
R06	2017-02-01	Accepted	Updated section 4.2 Mounting (removed horizontal mounting requirement, added hole numbering). Corrected table 3-3
R07	2017-05-30	Accepted	Updated section 4.2 (removed contact washers, added flat washers)
R08		Concept	Various updates for UL certification.
R09	2017-10-27	Concept	Various updates for UL certification. (Added RCD requirement, external PE connection to motor and different M12 protection caps),
R10	2018-02-07	Concept	Various updates for UL certification., WIFI -> WLAN, added WLAN channels
R11	2018-06-04	Concept	Various updates for UL certification
R12	2018-08-28	Concept	Update FCC modification notice, Update chapter 7 Radio
R13	18-10-2018	Concept	Added approved antenna list Updated safety warnings Updated mounting Minor changes for safety
R14_rc1 R14_rc2 R14_rc3 R14_rc4 R14_rc5	06-11-2018 19-11-2018 21-11-2018 22-11-2018 22-11-2018	Concept	Updated safety items Updated safety items Updated safety items Updated X108 connection to FE in Figure 4-2 Updated X104 (master) and X104+X105 (slave) circuit to basic insulation and updated conditions of use.
R14	23-11-2018	Concept	R14 is release of R14_rc5 (see line above) Used for CB report CER6752150130R01
R15	19-12-2018	Concept	Updated mounted instructions Added remark to X100 cabling requirements
R16	22-01-2019	Concept	Minor adjustments for regulations
R17	23-01-2019	Concept	Corrected antenna gain, added clarification for SWG (Slotted Wave Guide)

Contents

1. INTRODUCTION.....	5
1.1. PRODUCT BACKGROUND	5
2. CONDITIONS OF USE	5
2.1. GENERAL SAFETY WARNINGS	6
3. RATINGS	7
3.1. CONNECTOR X100	7
3.2. CONNECTOR X102	7
3.3. CONNECTOR X103	8
3.4. CONNECTOR X104	8
3.5. CONNECTOR X105	9
3.6. CONNECTOR X106	9
3.7. CONNECTOR X107	10
3.8. CONNECTOR X108	10
3.9. CONNECTOR X109	11
4. INSTALLATION.....	13
4.1. MOUNTING	13
4.2. CONNECTION DIAGRAMS	14
4.3. CONDUCTOR SELECTION	15
4.4. PROTECTIVE EARTH (PE) CONNECTION.....	15
4.5. LED	16
5. MASS AND MECHANICAL DIMENSIONS.....	17
5.1. MASS.....	17
5.2. MECHANICAL DIMENSIONS	17
6. ENVIRONMENTAL.....	18
6.1. CLIMATIC OPERATING CONDITIONS	18
6.2. STORAGE CONDITIONS	18
6.3. SHOCK AND VIBRATION	18
6.4. INGRES PROTECTION	19
6.5. DISPOSAL.....	19
7. RADIO.....	20
7.1. CHANNEL SUPPORT	21
7.2. LIST OF SUPPORTED ANTENNAS.....	21
8. CONTACT INFORMATION	23
APPENDIX A. COPYRIGHT LICENSE	24

List of Figures

FIGURE 4-1: MOUNTING OF THE CARRIER CONTROLLER.....	13
FIGURE 4-2 CONNECTION DIAGRAMS.....	14
FIGURE 4-3: PROTECTIVE EARTH CONNECTION.....	15
FIGURE 5-1: CARRIER CONTROLLER HOUSING DIMENSIONS.....	17
FIGURE 6-1 CAPACITOR REFORMING.....	18

List of Tables

TABLE 1-1: CARRIER CONTROLLER PN.....	5
TABLE 2-1: APPLICABLE SAFETY NORMS.....	6
TABLE 3-1: CONNECTOR X100.....	7
TABLE 3-2: APPROVED MATING PARTS X100.....	7
TABLE 3-3: CONNECTOR X102.....	7
TABLE 3-4: APPROVED MATING PARTS X102.....	7
TABLE 3-5: CONNECTOR X103.....	8
TABLE 3-6: APPROVED MATING PARTS X103.....	8
TABLE 3-7: CONNECTOR X104.....	8
TABLE 3-8: APPROVED MATING PARTS X104.....	9
TABLE 3-9: CONNECTOR X105.....	9
TABLE 3-10: APPROVED MATING PARTS X105.....	9
TABLE 3-11: CONNECTOR X106.....	9
TABLE 3-12: CONNECTOR X107.....	10
TABLE 3-13: APPROVED MATING PARTS X107.....	10
TABLE 3-14: CONNECTOR X108.....	11
TABLE 3-15: MOTOR INTERFACE ELECTRICAL SPECIFICATIONS.....	11
TABLE 3-16: APPROVED MATING PARTS X108.....	11
TABLE 3-17: CONNECTOR X109.....	12
TABLE 3-18: APPROVED MATING PARTS X109.....	12
TABLE 4-1 CONDUCTOR CABLE SELECTION.....	15
TABLE 4-2: MATERIALS FOR PE CONNECTION.....	16
TABLE 4-3 LED BEHAVIOUR.....	16
TABLE 5-1: CARRIER CONTROLLER HOUSING DIMENSIONS.....	17
TABLE 6-1: OPERATING CLIMATIC CONDITIONS.....	18
TABLE 6-2: STORAGE CLIMATIC CONDITIONS.....	18
TABLE 6-3: VIBRATION TEST.....	18
TABLE 6-4: SHOCK TEST.....	18
TABLE 6-5: RANDOM VIBRATION TEST.....	19
TABLE 6-6: INGRESS PROTECTION.....	19
TABLE 7-1: WLAN CHANNEL SUPPORT.....	21
TABLE 7-2: LIST OF SUPPORTED ANTENNAS.....	22
TABLE 8-1: COPYRIGHT LICENSES.....	24

1. Introduction

This manual is intended to cover basic installation and safety notes. During installation read and follow these instructions carefully and completely. All required information is provided in this manual.

This manual applies to the Carrier Controller, these can be identified by Prodrive Technologies PN:

Table 1-1: Carrier Controller PN

Item	Prodrive PN	Customer name	Customer PN
Carrier Controller Master (CE)	6752-1500-00xx	CCM	62802
Carrier Controller Master (CE) with DIO and ETH	6752-1500-01xx	CCM-IO-ETH	62803
Carrier Controller slave (CE)	6752-1500-02xx	CCS	62804
Carrier Controller slave (CE) with DIO	6752-1601-41xx	CCS-IO	62805
Carrier Controller Master (UL/CSA)	6752-1601-40xx	CCM, UL	64532
Carrier Controller Master (UL/CSA) with DIO and ETH	6752-1600-14xx	CCM-IO-ETH, UL	64533
Carrier Controller slave (UL/CSA)	6752-1600-15xx	CCS, UL	64534
Carrier Controller slave (UL/CSA) with DIO	6752-1601-42xx	CCS-IO, UL	64535

Note: xx = revision number

1.1. Product background

The product (Carrier controller) is primarily used as the motor drive in the field of distribution and sortation. This sorter is able to receive packages (e.g. baggage or parcel) and transports this to the correct end location where it exits the sorter. The sorter consists of a PLC controlling the whole system, a rigid rail supplying infrastructures like power and communication and carriers each with an individual carrier controller to drive the motors on the carrier.

2. Conditions of use

- Inspect the unit to ensure it was not damaged during shipment
- Product shall only be installed by adequately qualified personnel
- Product shall not be touched and/or installed and/or mounted with power enabled
- Product shall only be used in the environment specified in section 6
- Product shall be installed as specified in section 3 + 4
- Product is not compatible with RCD/RCM Type A or AC, where required a RCD/RCM type B must be used
- Product maintenance shall only be performed by Prodrive Technologies
- Product repairs shall only be performed by Prodrive Technologies
- Product has a short circuit rating of 5kA
- The application shall protect X100 from external impact
- The PE conductor shall be connected at all times when power is supplied to the CC
- The motor shall be externally connected to PE
- Product does not incorporate motor overtemperature protection for the motor. Where required, integral thermal protection shall be provided in or on the motor(s)
- This device does not incorporate internal motor overload protection for the motor and is intended to be used with external or remote overload protection.
- Product is intended for industrial installations
 - USA and Canada: For use only in industrial machinery NFPA 79 applications
- Do not put machine into operation before ensuring “(EMC) Directive 2014/30/EU” and “Machinery Directive 2006/42/EC”
- Product has no protection for UV light
- The product shall be installed in an environment of pollution degree 3 or lower
- Product is not intended to be directly connected to the supply mains, but is intended to be supplied by a transformer or similar means providing galvanic isolation. The product is evaluated for use in Overvoltage category II only.
- The wiring assemblies for the connectors X102, X103, X104, X105, X107, X108 and X109 shall be tightened with a torque rating of 0.6 Nm.

- In case, the cable assemblies for X102, X103, X104, X105, X107, X108 and/or X109 are not installed on the product, each of the unused connector shall be closed with a sealing cap, PROT-M12 MS-M1414148 manufactured by Phoenix. These sealing caps shall also to be tightened with 0.6 Nm.
- The product is powered by a 100V DC power supply either isolated or non-isolated. The earthing system must be evaluated on system level for safe operation of the product.

2.1. General safety warnings

CAUTION!

During the UL evaluation, only Risk of Electrical Shock and Risk of Fire aspects were investigated. Functional Safety aspects were not evaluated

CAUTION!

Suitable For Use On A Circuit Capable Of Delivering Not More Than 5000 rms Symmetrical Amperes, 100 Volts DC Maximum

CAUTION!

Integral solid state short circuit protection does not provide branch circuit protection. Branch circuit protection must be provided in accordance with the National Electrical Code and any additional local codes





CAUTION!

High temperature on electronics housing, Risk of burns

NOTICE:

Changes or modifications made to this equipment not expressly approved by Prodrive Technologies B.V. may void the FCC authorization to operate this equipment.

Table 2-1: Applicable safety norms

Norm	Description	Label ¹
CSA-22.2 no. 274-17	Adjustable speed drives (Canada)	
UL 61800-5-1	Power conversion equipment (US)	
IEC-EN 61800-5-1	Adjustable Speed Electrical Power Drive Systems - Safety Requirements - Electrical, Thermal and Energy (Europe)	

Note[1]: Depending on model, only applicable if logo is present on product label

3. Ratings

3.1. Connector X100

Type: Power input
 Connector type: Harting Han 3A: 09200030827 + 09120023052 + 09320006108
 Shielding: None
 Voltage class: DVC-B / Potential hazardous voltage, not isolated from DC-input
 Cable voltage rating: ≥120 VDC
 Over voltage category: OVC II with galvanic separation from mains
 Hot swappable: No
 Label: X100

ATTENTION! Type 5 enclosure rating is only achieved when approved mating parts are used as shown in the Approved mating parts table below

ATTENTION! Before connecting or disconnecting X100 the power must be switched off.

Table 3-1: Connector X100

Pin	I/O	Mnemonic	Description / Conditions
1	PWR	DC_IN+	Positive power input / 100V @ 9Arms
2	PWR	DC_IN- (GND)	Negative power input / 100V @ 9Arms
PE	nc	n/a	Not connected

Table 3-2: Approved mating parts X100

Manufacturer	Mfr. PN	Type	Description / Conditions	Remarks
Beumer	1204660514	Cable	Power cable	Cable assembly build identical to 1204660514 with the only exception of the cable lengths is also acceptable

3.2. Connector X102

Type: Pick-up interface
 Connector type: M12 4p Female D-Type, Phoenix 1411936
 Shielding: Connector shield connected to housing
 Voltage class: DVC-B / Potential hazardous voltage, not isolated from DC-input
 Cable voltage rating: ≥120 VDC
 Hot swappable: No
 Label: X102
 Torque requirement: 0.6 Nm

ATTENTION! Type 5 enclosure rating is only achieved when approved mating parts are used as shown in the Approved mating parts table below

ATTENTION! Before connecting or disconnecting X102 the power must be switched off.

Table 3-3: Connector X102

Pin	I/O	Mnemonic	Description / Conditions	Pair
1	I/O	PU_P	Proprietary half duplex differential interface	A
2	I/O	PU_N	Proprietary half duplex differential interface	A
3	PWR	+15V_PU	Positive supply (+15V, 50mA)	B
4	PWR	GND	Negative supply (+15V, 50mA)	B

Table 3-4: Approved mating parts X102

Manufacturer	Mfr. PN	Type	Description / Conditions	Remarks
Phoenix	1414148	Sealing cap	PROT-M12 MS-M	
SEW	18191460	Cable	Signalkabel M04D-C4-CW45	

3.3. Connector X103

Type: IO
 Connector type: M12 8p Female A-Type, Phoenix 1457678
 Shielding: Connector shield connected to housing
 Voltage class: DVC-B / Potential hazardous voltage, not isolated from DC-input
 Cable voltage rating: ≥120 VDC
 Hot swappable: No
 Label: X103
 Torque requirement: 0.6 Nm

ATTENTION! Type 5 enclosure rating is only achieved when approved mating parts are used as shown in the Approved mating parts table below

ATTENTION! Before connecting or disconnecting X103 the power must be switched off.

Table 3-5: Connector X103

Pin	I/O	Mnemonic	Description / Conditions
1	O	HV-OUT_0	Switchable output 0 (24V, 200mA)
2	PWR	GND	GND
3	I	HV-IN_0	Input 0 (24V)
4	PWR	GND	GND
5	O	HV-OUT_1	Switchable output 1 (24V, 200mA)
6	PWR	GND	GND
7	I	HV-IN_1	Input 1 (24V)
8	PWR	GND	GND

Table 3-6: Approved mating parts X103

Manufacturer	Mfr. PN	Type	Description / Conditions	Remarks
Phoenix	1414148	Sealing cap	PROT-M12 MS-M	
Phoenix	1522817	Cable	Sensor/actuator cable - SAC-8P-M12MR/ 1,5-PUR SH	

3.4. Connector X104

Type: Fieldbus IN
 Connector type: M12 8p Male A-Type, Phoenix 1457555
 Shielding: Connector shield connected to housing
 Voltage class: DVC-B / Potential hazardous voltage, not isolated from DC-input
 Cable voltage rating: ≥120 VDC
 Hot swappable: No
 Label: X104
 Torque requirement: 0.6 Nm

ATTENTION! Type 5 enclosure rating is only achieved when approved mating parts are used as shown in the Approved mating parts table below

ATTENTION! Before connecting or disconnecting X104 the power must be switched off.

Table 3-7: Connector X104

Pin	I/O	Mnemonic	Description / Conditions	Pair
1	I/O	SL_H	Proprietary half duplex differential interface	A
2	I/O	SL_L	Proprietary half duplex differential interface	
3	I	M_RX_P	Proprietary full duplex differential interface	B
4	I	M_RX_N	Proprietary full duplex differential interface	
5	O	M_TX_P	Proprietary full duplex differential interface	C
6	O	M_TX_N	Proprietary full duplex differential interface	
7	PWR	+15V_FBI	Positive supply input (+15V_FBI)	D
8	PWR	GND_FBI	Negative supply input (+15V_FBI)	

Table 3-8: Approved mating parts X104

Manufacturer	Mfr. PN	Type	Description / Conditions	Remarks
Beumer	196675	Cable	Beumer Fieldbus cable	Various lengths available, Mfr PN (196675) is followed by the length in cm separated by a “.”

3.5. Connector X105

Type: Fieldbus OUT
 Connector type: M12 8p Female A-Type, Phoenix 1457678
 Hot swappable: No
 Voltage class: DVC-B / Potential hazardous voltage, not isolated from DC-input
 Cable voltage rating: ≥120 VDC
 Shielding: Connector shield connected to housing
 Label: X105
 Torque requirement: 0.6 Nm

ATTENTION! Type 5 enclosure rating is only achieved when approved mating parts are used as shown in the Approved mating parts table below

ATTENTION! Before connecting or disconnecting X105 the power must be switched off.

Table 3-9: Connector X105

Pin	I/O	Mnemonic	Description / Conditions	Pair
1	I/O	SL_H	Proprietary half duplex differential interface	A
2	I/O	SL_L	Proprietary half duplex differential interface	
3	O	M_TX_P	Proprietary full duplex differential interface	B
4	O	M_TX_N	Proprietary full duplex differential interface	
5	I	M_RX_P	Proprietary full duplex differential interface	C
6	I	M_RX_N	Proprietary full duplex differential interface	
7	PWR	+15V_FBO	MCC: Positive supply output (+15V, 1A) SCC: connection to X104p7	D
8	PWR	GND	MCC: Negative supply output (+15V, 1A) SCC: connection to X104p8	

Table 3-10: Approved mating parts X105

Manufacturer	Mfr. PN	Type	Description / Conditions	Remarks
Phoenix	1414148	Sealing cap	PROT-M12 MS-M	
Beumer	196675	Cable	Beumer Fieldbus cable	Various lengths available, Mfr PN (196675) is followed by the length in cm separated by a “.”

3.6. Connector X106

Type: WLAN
 Connector type: RP-SMA
 Shielding: Connector shield connected to housing
 Voltage class: DVC-A
 Cable voltage rating: n/a
 Hot swappable: No
 Label: X106

ATTENTION! Cables connected to X106 and X107 (DVC-A/ELV circuit) must be routed separate from cabling to X100,X102,X103,X104,X105,X108 and X109 (DVC-B and DVC-C circuit).

Table 3-11: Connector X106

Pin	I/O	Mnemonic	Description / Conditions
1	I	ANT	WLAN antenna
C	I	Chassis	Connected to GND_PELV

3.7. Connector X107

Type: Ethernet
 Connector type: M12 8p Female X-Type, Phoenix 1402457
 Shielding: Connector shield connected to housing
 Voltage class: DVC-A
 Cable voltage rating: n/a
 Hot swappable: Yes
 Label: X107
 Torque requirement: 0.6 Nm

ATTENTION! Type 5 enclosure rating is only achieved when approved mating parts are used as shown in the Approved mating parts table below

ATTENTION! Cables connected to X106 and X107 (DVC-A/ELV circuit) must be routed separate from cabling to X100,X102,X103,X104,X105,X108 and X109 (DVC-B and DVC-C circuit).

Table 3-12: Connector X107

Pin	I/O	Mnemonic	Description / Conditions	Pair
1	I	Rx+	Positive Receive	A
2	I	Rx-	Negative Receive	
3	O	Tx+	Positive Transmit	B
4	O	Tx-	Negative Transmit	
5	-	-	-	
6	-	-	-	
7	-	-	-	
8	-	-	-	

Table 3-13: Approved mating parts X107

Manufacturer	Mfr. PN	Type	Description / Conditions	Remarks
Phoenix	1414148	Sealing cap	PROT-M12 MS-M	
Phoenix	Various	Cable	Network cable VS-M12MSS-IP20-94F	Various lengths available For example 15m (Mfr PN 1440643)

3.8. Connector X108

Type: Motor connection
 Connector type: M12 4p Female S-Power, Phoenix 1406409
 Shielding: Connector shield connected to housing and PIN
 Voltage class: DVC-C / Potential hazardous voltage, not isolated from DC-input
 Cable voltage rating: ≥120 VDC
 Hot swappable: No
 Label: X108
 Torque requirement: 0.6 Nm

ATTENTION! The Carrier Controller units do not provide safety grounding for the external motor installed on connector X108. The grounding provision on X108 is only intended for functional grounding purposes. The safety grounding/bonding of the motor shall occur separately from the Carrier Controller units in accordance with the requirements of the applicable Electrical codes/Standards.

ATTENTION! Failure to correctly connect the protective earth of the motor can result in a safety hazard.

ATTENTION! Type 5 enclosure rating is only achieved when approved mating parts are used as shown in the Approved mating parts table below

ATTENTION! Before connecting or disconnecting X108 the power must be switched off.

Table 3-14: Connector X108

Pin	I/O	Mnemonic	Description / Conditions
1	O	L1	Motor phase 1 output
2	O	L2	Motor phase 2 output
3	O	L3	Motor phase 3 output
4	FE	FE	FE connection
-	S	Shield	Shield for cable

Motor output specification:

- 3 phases BLDC
- Protected against short circuit
 - No safety hazard
 - DC-Power-Bus is not shorted
- Functional protections
 - All protections disable end-stage if not mentioned otherwise
 - Instantaneous current ($I_{PHASE, OCP}$)
 - RMS current ($I_{PHASE, RMS}$)
 - DC-Power-Bus voltage
 - Below $V_{DC-POWER-BUS, NOSTART}$ no movement is started
 - Under voltage of DC-Power-Bus below $V_{DC-POWER-BUS, UVP}$
 - Over voltage of DC-Power-Bus above $V_{DC-POWER-BUS, OVP}$
 - Temperature
 - Over temperature of end-stage

Table 3-15: Motor Interface electrical specifications

Item	Comments	Min	Typ	Max	Unit
$V_{DC-POWER-BUS, OVP}$	Over voltage protection of DC-Power-Bus			120	[V]
$V_{DC-POWER-BUS, UVP}$	Under voltage protection of DC-Power-Bus	30			[V]
$V_{DC-POWER-BUS}$	Voltage of DC-Power-Bus	30		110	[V]
$V_{DC-POWER-BUS, NOSTART}^1$	Voltage of DC-Power-Bus below which no movement is started			85	[V]
$I_{PHASE, RMS}$	RMS phase current			6.5	[A _{RMS}]
$I_{PHASE, LIMIT}$	Adjustable phase peak current limit	10		45	[A]
$I_{PHASE, OCP}$	Over current protection	45			[A]
$L_{MOTOR, PH-PH}$	Inductance per motor phase to phase	0.3		10	[mH]
$R_{MOTOR, PH-PH}$	Resistance per motor phase to phase	0.25			[Ω]
$f_{MOTOR, ELE}$	Electrical motor frequency			400	[Hz]
f_{SW}	Switching frequency		20		[kHz]
δ	Duty-cycle limit during operation	2		96	[%]

Table 3-16: Approved mating parts X108

Manufacturer	Mfr. PN	Type	Description / Conditions	Remarks
Phoenix	1414148	Sealing cap	PROT-M12 MS-M	
Finecables	BYD6.646.003	Motor	Motor cable	

3.9. Connector X109

- Type: Hall sensor connection
- Connector type: M12 5p Female A-Type, Phoenix 1457649
- Shielding: Connector shield connected to housing
- Voltage class: DVC-B / Potential hazardous voltage, not isolated from DC-input
- Cable voltage rating: ≥ 120 VDC
- Hot swappable: No
- Label: X109
- Torque requirement: 0.6 Nm

ATTENTION! Type 5 enclosure rating is only achieved when approved mating parts are used as shown in the Approved mating parts table below

ATTENTION! Before connecting or disconnecting X109 the power must be switched off.

Motor hall sensor specification:

- 3 phase hall sensor interface
- +15V supply for hall sensors
- Hall sensor fault detection
- Resettable fuse

Table 3-17: Connector X109

Pin	I/O	Mnemonic	Description / Conditions
1	I	HALL_1	Hall phase 1 input (+15V)
2	I	HALL_2	Hall phase 2 input (+15V)
3	I	HALL_3	Hall phase 3 input (+15V)
4	PWR	VP_HALL+	Positive supply (+15V, 25mA)
5	PWR	GND	Negative hall supply
-	S	Shield	Shield for cable

Table 3-18: Approved mating parts X109

Manufacturer	Mfr. PN	Type	Description / Conditions	Remarks
Phoenix	1414148	Sealing cap	PROT-M12 MS-M	
Finecables	BYD6.646.004	Motor	Hall sensor cable	

4. Installation

This chapter specifies the installation requirements of the Carrier Controller.

4.1. Mounting

See Figure 4-1. The Carrier Controller shall be mounted on a flat surface capable of carrying the mass of the Carrier Controller plus all attached cables. The Carrier Controller shall be fixed to the mounting surface through zinc-plated steel M6 screws using mounting holes 1, 2, 5, and 6 as indicated in the detail in the top-right of Figure 4-1. Mounting holes 3 and 4 are optional, and are recommended for use in environments with high vibration levels.

It is recommended to use M6 zinc-plated steel washers or similar geometry at the M6 screw hole locations on the mounting surface to keep Carrier Controller bottom and mounting surface separated.

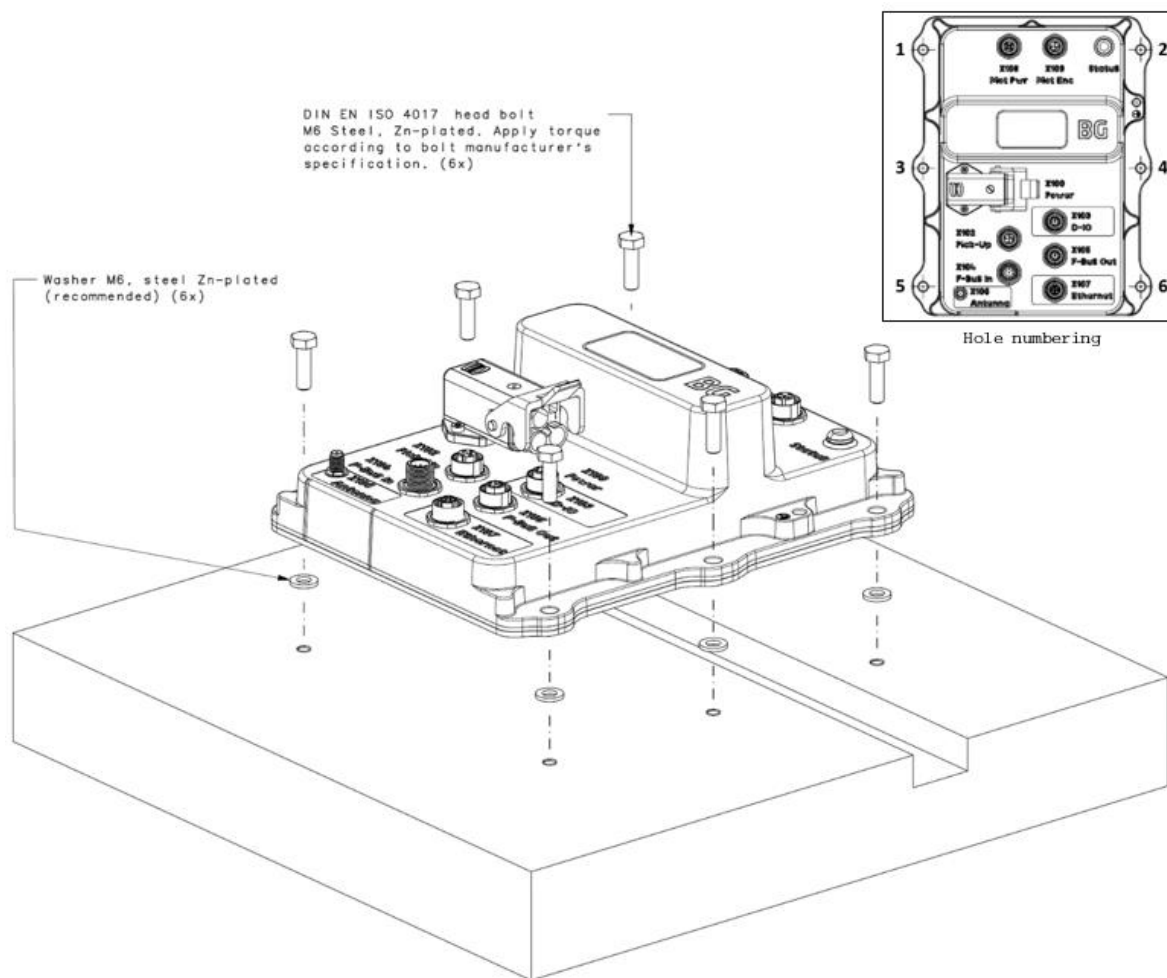

Figure 4-1: Mounting of the Carrier Controller

4.2. Connection diagrams

Wiring diagram of the product is described in Figure 4-2, the product can be connected in a chain starting and ending with a master controller (can be the same master). In between up to 60 slaves controller can be connected to the slave bus.

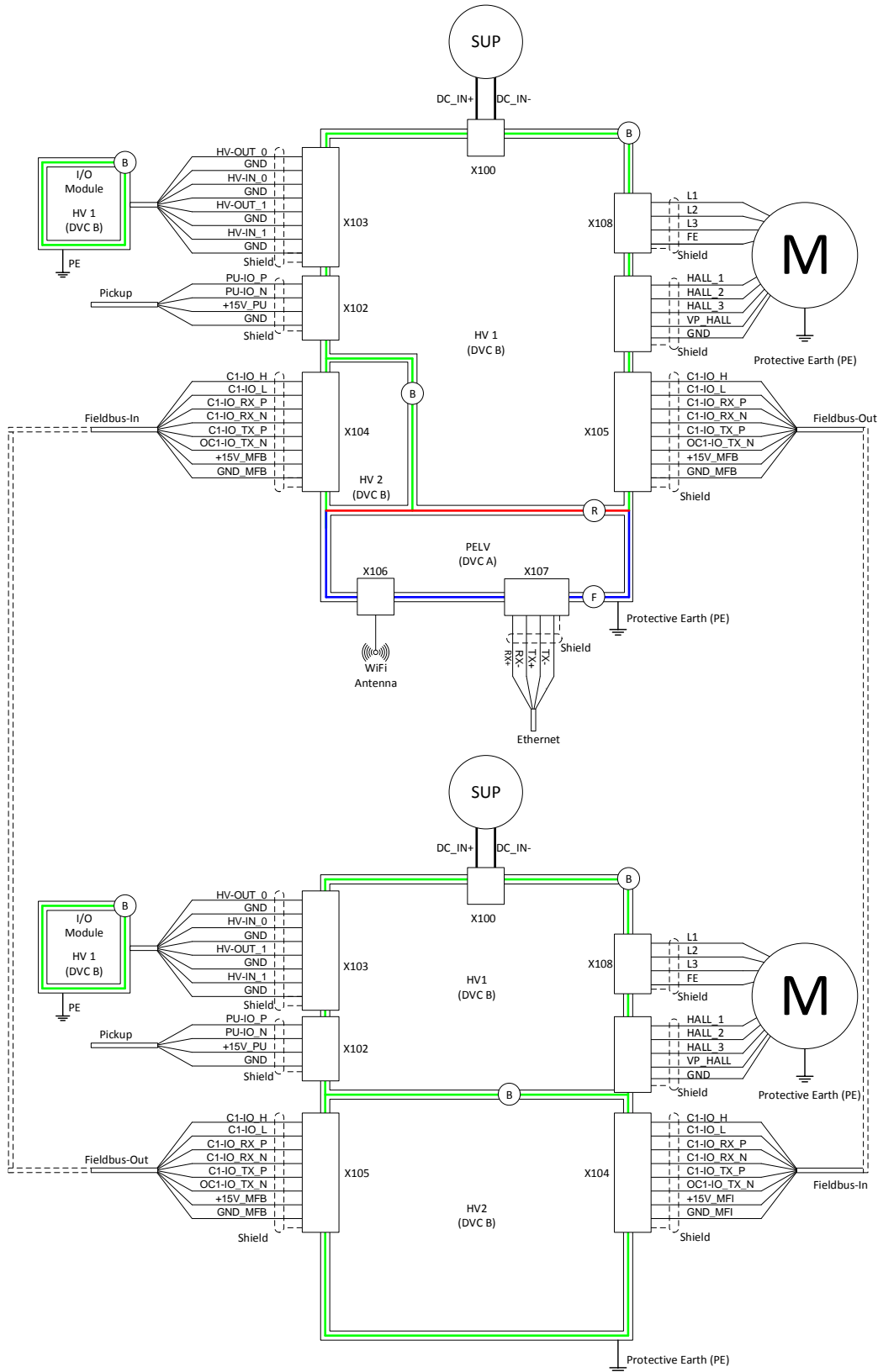

Figure 4-2 Connection diagrams

4.3. Conductor selection

Cables used for power connectors need to comply with the requirements in Table 4-1.

Table 4-1 conductor cable selection

Parameter	Requirement	Remark
Voltage rating	Minimum 120V	
DC input wire cross section	6.0mm ²	
Protective Earth conductor cross section	6.0mm ²	
Motor output wire cross section	At least 1.5mm ²	
Motor earth bonding conductor cross section.	At least 6.0mm ²	Product does not provide earth bonding section.

4.4. Protective earth (PE) connection

Prior to installing any other cable, the Carrier Controller must be connected to earth by fixing an earthing wire with cable lug (1) using a screw (2), two flat washers (3), and two nuts (4) to the hole marked with the PE logo ⊕ as indicated in Figure 4-3 and Table 4-2.

The earthing wire must have a cross-sectional area of at least 6 mm² if copper is used as a conductor. Otherwise, the cross-sectional area of the earthing wire shall be such that its conductance is equivalent to that of a 6 mm² copper wire, and shall not be less than 4 mm².

ATTENTION! It is not allowed to use the hole marked with the PE logo, screw (2), rings (3) and nuts (4) for any other purpose than mechanically and electrically connecting the earthing wire to the Carrier Controller.

ATTENTION! Enclosure and fasteners of the Carrier Controller are aluminum and zinc-plated steel, respectively. Earthing wire, cable lug, earthing connector and fastener materials must be chosen such that the current-carrying capacity of the protective earth connection will not be impaired by electrochemical corrosion.

ATTENTION! Failure to correctly connect the protective earth can result in a safety hazard.

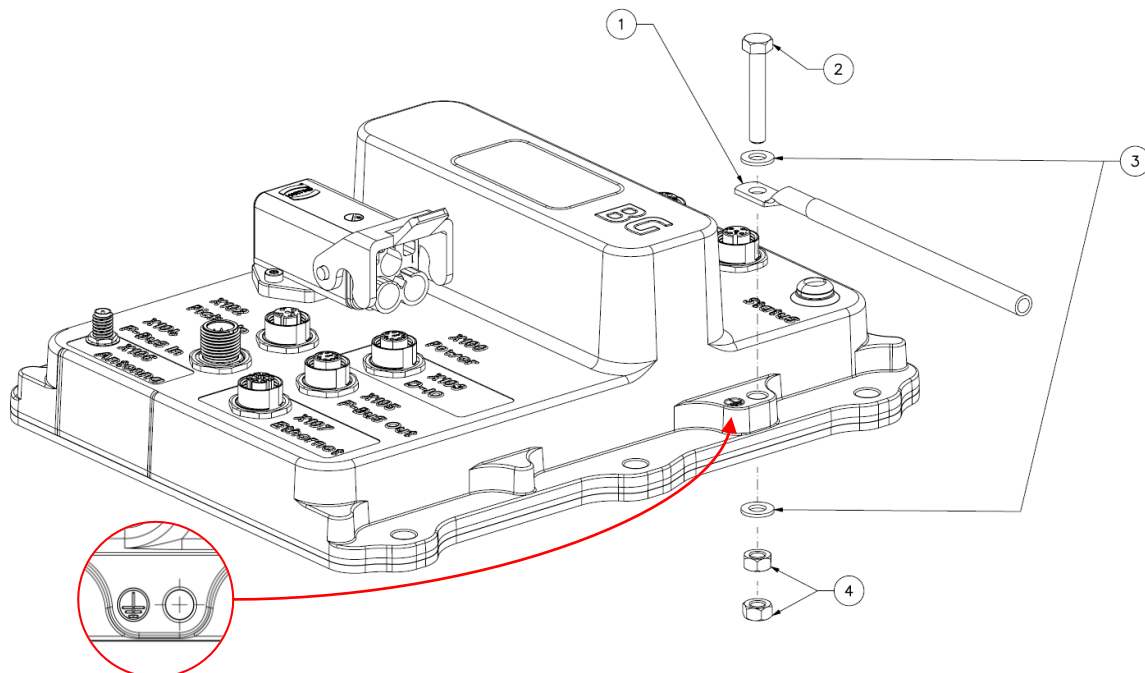

Figure 4-3: Protective earth connection

Table 4-2: Materials for PE connection

#	Component	Description	Material
2	Screw	M5x25	Zinc-plated steel
3	Flat washer	M5	
3	Nut	M5	

4.5. LED

Table 4-3 shows which condition leads to which LED behaviour. Following properties apply:

- The LED behaviour is determined by the priority mentioned in Table 4-3, where a lower number denotes a higher priority. All conditions with priority 3 are mutually exclusive.

Table 4-3 LED Behaviour

Prio.	Condition	Behaviour
1	Can bus in error-passive or bus-off state	Magenta (red+blue)
2	State <i>WaitCanAddress</i>	Blue
3	<i>Loader</i> mode	Blue blinking
3	<i>Application</i> mode, in state <i>Error</i>	Red
3	<i>Application</i> mode, in state <i>Reset</i>	Red blinking
3	<i>Application</i> mode, in state <i>Setup</i>	Yellow (Green+Red)
3	<i>Application</i> mode, in state <i>Startup, Moving, Settling or FindHome</i>	Green
3	<i>Application</i> mode, in state <i>Off</i>	Green blinking

5. Mass and mechanical dimensions

5.1. Mass

All Carrier Controller configurations have a mass of 1.4 ± 0.1 kg.

5.2. Mechanical dimensions

Figure 5-1 and Table 5-1 show Carrier Controller housing dimensions. These dimensions are common to all Carrier Controller configurations. The Figure 5-1 shows the Master + IO + ETH configuration. (Depending on variant some connectors might not be available)

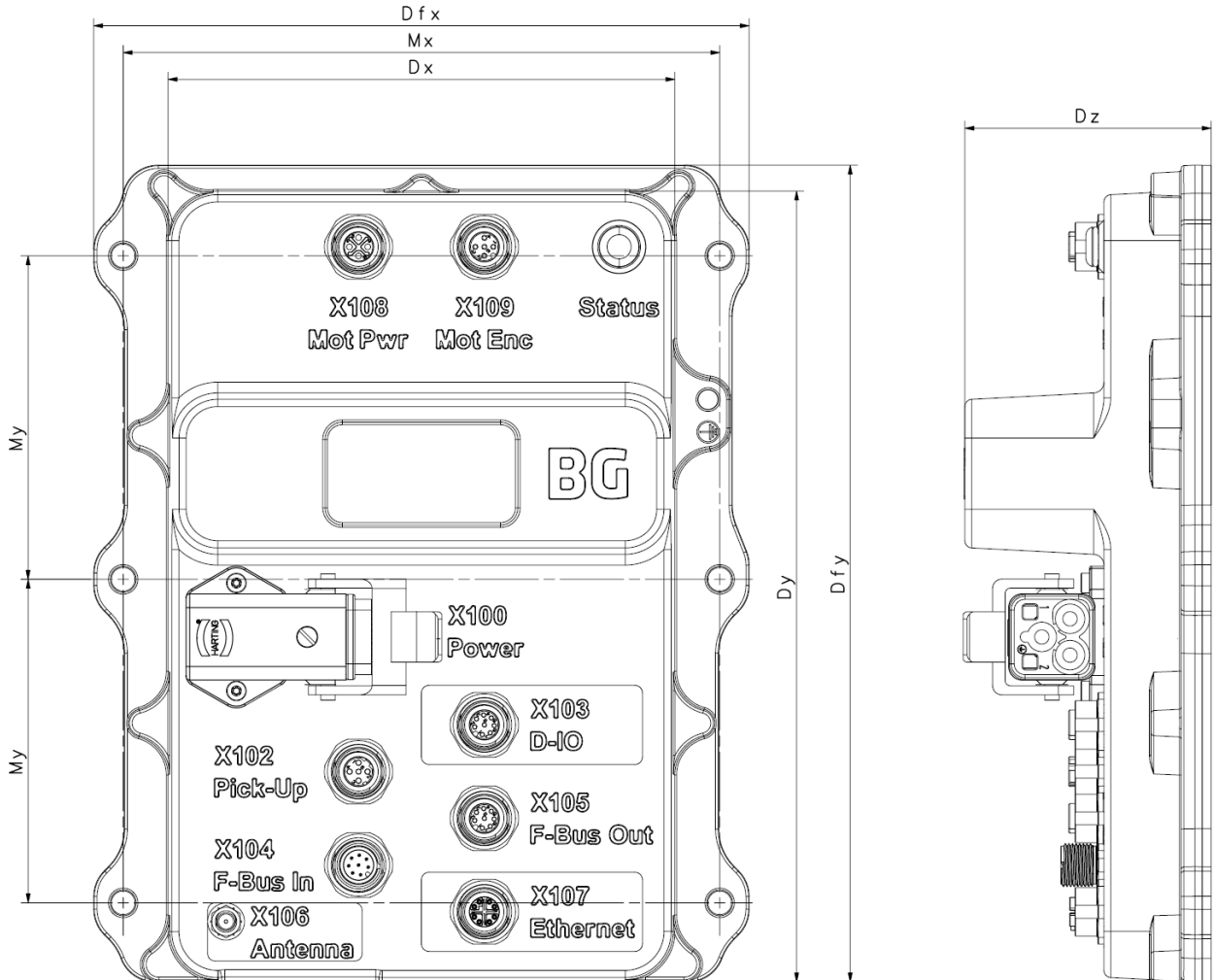

Figure 5-1: Carrier Controller housing dimensions

Table 5-1: Carrier Controller housing dimensions

Symbol	Description	Typ	Tolerance	Unit
Dfx	Flange width	182	± 1	[mm]
Dfy	Flange length	227	± 1	[mm]
Dx	Housing width	141	± 0.9	[mm]
Dy	Housing length	220	± 1	[mm]
Dz	Housing height	68.5	± 0.8	[mm]
Mx	Mounting hole distance in width direction	166	± 1	[mm]
My	Mounting hole distance in length direction	90	± 0.8	[mm]

6. Environmental

6.1. Climatic Operating conditions

Table 6-1: Operating climatic conditions

Parameter	Description	Min	Typ	Max	Unit	Remarks
T _{AMB}	Operating ambient temperature	0	22	45	[°C]	
RH _{AMB}	Operating humidity	0		95	[%]	Relative humidity (no condensation)
T _{AMB/dT}	Operating ambient temperature change rate	-5		5	[°C/min]	
H _{ALT}	Operating altitude AMSL			1000	[m]	AMSL (Above Mean Sea Level)

The product shall be installed in an environment of pollution degree 3 or lower.
The product does not have protection for UV-light.

6.2. Storage conditions

Table 6-2: Storage climatic conditions

Parameter	Description	Min	Typ ¹	Max	Unit	Remarks
T _{ST,AMB}	Storage ambient temperature	-10	22	60	[°C]	
RH _{ST,AMB}	Storage humidity	0		95	[%]	Relative humidity (no condensation)
T _{ST,AMB/dT}	Storage ambient temperature change rate	-5		5	[°C/min]	
H _{ST,ALT}	Storage altitude AMSL			1000	[m]	AMSL (Above Mean Sea Level)
t _{SHELF}				5	[yr]	Shelf life > 12 months requires capacitor reforming, see Figure 6-1

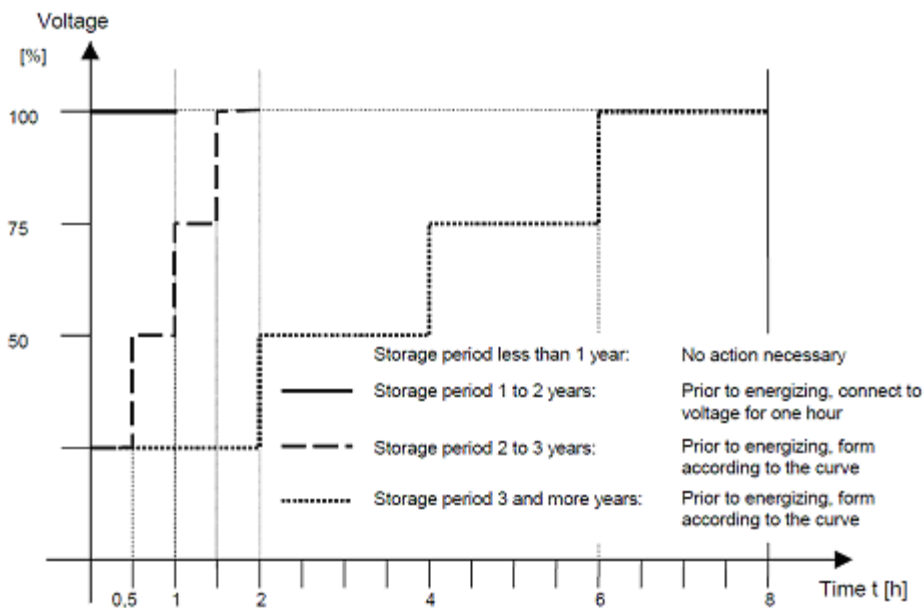

Figure 6-1 Capacitor reforming

6.3. Shock and vibration

Table 6-3: Vibration test

Test procedure	IEC 60068-2-6
Condition	1Hz to 500 Hz; 20m/s ² amplitude; 20 frequency cycles in each axis Unpacked
Number of axes	3

Table 6-4: Shock test

Test procedure	IEC 60068-2-27
----------------	----------------

Condition	Peak acceleration: 250m/s ² , Duration: 6ms, 1000 shocks in each axis, Half-sine Packed
Number of axes	3 (positive and negative for each)

Table 6-5: Random vibration test

Test procedure	IEC 60068-2-64:2008
Condition	Acc. to table A.6, Categories 2a, 2b, 2c, Unpacked
Number of axes	3

6.4. Ingress protection

Table 6-6: Ingress protection

Region	Description	Value	Unit	Remarks
EU	IP rating of carrier controller	IP54	[-]	Protection from dust and splashing water based on NEN-EN-IEC60529 IP rating is only achieved with connector cables and/or protection caps.
USA/CA	UL enclosure rating of carrier controller	Type 5	[-]	Enclosure rating is achieved with connector cables and/or protection caps. (Available from Phoenix 1414148). See the corresponding connector paragraph in chapter 3 for correct cables and/or protection caps.

6.5. Disposal

This product should be treated as industrial waste when disposed. Dispose accordingly and comply with all local regulations.

7. Radio

FCC (UL/CSA models)

This device complies with Part 15 of the FCC Rules.

Operation is subject to the following two conditions:

- (1) this device may not cause harmful interference, and
- (2) this device must accept any interference received, including interference that may cause undesired operation.

Note: This equipment has been tested and found to comply with the limits for a Class B digital device, pursuant to part 15 of the FCC Rules. These limits are designed to provide reasonable protection against harmful interference in a residential installation. This equipment generates, uses and can radiate radio frequency energy and, if not installed and used in accordance with the instructions, may cause harmful interference to radio communications. However, there is no guarantee that interference will not occur in a particular installation. If this equipment does cause harmful interference to radio or television reception, which can be determined by turning the equipment off and on, the user is encouraged to try to correct the interference by one or more of the following measures:

- Reorient or relocate the receiving antenna.
- Increase the separation between the equipment and receiver.
- Connect the equipment into an outlet on a circuit different from that to which the receiver is connected.
- Consult the dealer or an experienced radio/TV technician for help.

RSS-247 of Industry Canada (UL/CSA models)

ENGLISH

This device complies with Industry Canada licence-exempt RSS standard(s).

Operation is subject to the following two conditions:

1. this device may not cause interference, and
2. this device must accept any interference, including interference that may cause undesired operation of the device.

This radio transmitter has been approved by Industry Canada to operate with the antenna types listed in the respective Operating Instructions with the maximum permissible gain and required antenna impedance for each antenna type indicated. Antenna types not included in this list, having a gain greater than the maximum gain indicated for that type, are strictly prohibited for use with this device.

Under Industry Canada regulations, this radio transmitter may only operate using an antenna of a type and maximum (or lesser) gain approved for the transmitter by Industry Canada. To reduce potential radio interference to other users, the antenna type and its gain should be so chosen that the equivalent isotropically radiated power (e.i.r.p.) is not more than that necessary for successful communication.

To reduce potential radio interference to other users, the antenna type and its gain should be so chosen that the equivalent isotropically radiated power (e.i.r.p.) is not more than that permitted for successful communication.

That the device for the band 5150-5250 MHz is only for indoor usage to reduce potential for harmful interference to co-channel mobile satellite systems.

Users should also be cautioned to take note that high power radars are allocated as primary users (meaning they have priority) of 5250-5350 MHz and 5650-5850 MHz and these radars could cause interference and/or damage to LE-LAN devices.

This equipment complies with IC RSS-102 radiation exposure limits set forth for an uncontrolled environment. This equipment should be installed and operated with minimum distance 20cm between the radiator & your body.

FRENCH

Le présent appareil est conforme aux CNR d'Industrie Canada applicables aux appareils radio exempts de licence. L'exploitation est autorisée aux deux conditions suivantes:

- (1) l'appareil ne doit pas produire de brouillage, et*

(2) l'appareil doit accepter tout brouillage radioélectrique subi, même si le brouillage est susceptible d'en compromettre le fonctionnement.

Industrie Canada a autorisé cet émetteur radio à fonctionner avec les types d'antenne énumérés dans le mode d'emploi correspondant, avec le gain maximal admissible et l'impédance d'antenne requise pour chaque type d'antenne indiqué. Les types d'antenne non inclus dans cette liste, ayant un gain supérieur au gain maximal indiqué pour ce type, sont strictement interdits d'utilisation avec cet appareil.

Selon les réglementations d'Industrie Canada, cet émetteur radio ne peut fonctionner qu'avec une antenne d'un type et d'un gain maximal (ou inférieur) approuvé pour l'émetteur par Industrie Canada. Pour réduire le risque de brouillage radioélectrique causé aux autres utilisateurs, le type d'antenne et son gain doivent être choisis de manière à ce que la puissance rayonnée isotrope équivalente (e.i.r.p.) ne soit pas supérieure à celle nécessaire au succès de la communication. Pour réduire le risque de brouillage radioélectrique causé aux autres utilisateurs, le type d'antenne et son gain doivent être choisis de manière à ce que la puissance rayonnée isotrope équivalente (par exemple) ne soit pas supérieure à celle autorisée pour une communication réussie.

Que le dispositif pour la bande 5150-5250 MHz soit uniquement destiné à une utilisation en intérieur afin de réduire le risque de brouillage préjudiciable des systèmes de télécommunication par satellite mobiles dans le même canal.

Les utilisateurs doivent également noter que les radars à haute puissance sont attribués en tant qu'utilisateurs principaux (c'est-à-dire qu'ils ont la priorité) de 5250-5350 MHz et 5650-5850 MHz et que ces radars peuvent causer des interférences et / ou des dommages aux dispositifs LE-LAN. Cet équipement est conforme aux limites d'exposition au rayonnement IC RSS-102 définies pour un environnement non contrôlé. Cet équipement doit être installé et utilisé à une distance minimale de 20 cm entre le radiateur et votre corps.

7.1. Channel support

The master controller supports the channels shown in Table 7-1.

Table 7-1: WLAN channel support

Channel	Center frequency [Mhz]	Frequency range [Mhz]	Bandwidth [Mhz]	Band	Channel limitations			Remarks
					EU	CA	USA	
36	5180	5170–5190	20	U-NII-1	Indoors	Indoors	-	
40	5200	5190–5210	20	U-NII-1	Indoors	Indoors	-	
44	5220	5210–5230	20	U-NII-1	Indoors	Indoors	-	
48	5240	5230–5250	20	U-NII-1	Indoors	Indoors	-	
52	5260	5250–5270	20	U-NII-2A	Indoors DFS/TPC	DFS	DFS	
56	5280	5270–5290	20	U-NII-2A	Indoors DFS/TPC	DFS	DFS	
60	5300	5290–5310	20	U-NII-2A	Indoors DFS/TPC	DFS	DFS	
64	5320	5310–5330	20	U-NII-2A	Indoors DFS/TPC	DFS	DFS	
100	5500	5490–5510	20	U-NII-2C	DFS/TPC	DFS	DFS	
104	5520	5510–5530	20	U-NII-2C	DFS/TPC	DFS	DFS	
108	5540	5530–5550	20	U-NII-2C	DFS/TPC	DFS	DFS	
112	5560	5550–5570	20	U-NII-2C	DFS/TPC	DFS	DFS	
116	5580	5570–5590	20	U-NII-2C	DFS/TPC	DFS	DFS	
132	5660	5650–5670	20	U-NII-2C	DFS/TPC	DFS	DFS	
136	5680	5670–5690	20	U-NII-2C	DFS/TPC	DFS	DFS	
140	5700	5690–5710	20	U-NII-2C	DFS/TPC	DFS	DFS	

7.2. List of supported antennas

RSS-247 of Industry Canada (UL/CSA models)

ENGLISH

This radio transmitter 9389A-CCMUL has been approved by Innovation, Science and Economic Development Canada to operate with the antenna types listed below, with the maximum permissible gain indicated. Antenna types not included in this list that have a gain greater than the maximum gain indicated for any type listed are strictly prohibited for use with this device.

FRENCH

Cet émetteur radio 9389A-CCMUL a été approuvé par Innovation, Sciences et Développement économique Canada pour fonctionner avec les types d'antennes énumérés ci-dessous, avec le gain maximal admissible indiqué. Les types d'antenne non inclus dans cette liste et dont le gain est supérieur au gain maximal indiqué pour l'un des types répertoriés ne sont strictement pas autorisés pour une utilisation avec cet appareil.

Table 7-2: List of supported antennas

Mfr	Mfr PN	Description	Impedance	Max. ant.. Gain.
SEW Eurodrive	Coupler R-SMA 5.0 GHz	SWG (Slotted Wave Guide) Antenna	50 Ohm	-3.8 dBi
Eupen	RMC 12-CH	Eucaray 1/2" radiating cable	50 Ohm	0 dBi

8. Contact information

Prodrive Technologies B.V.
Science Park Eindhoven 5501
5692 EM Son
The Netherlands
Phone: +31 40 2676200
Fax: +31 40 2676201
Website: prodrive-technologies.com

Appendix A. Copyright License

The following table lists the copyrighted and or licensed items related to this product.

Table 8-1: Copyright Licenses

Component	License	Remark
Linux Kernel	GPLv2	
GNU C Library	LGPL2.1	