

PRO-FORM[®]

R-930

USER'S MANUAL

SEARS

Model No. 831-257750

Serial No. _____

Write the serial number in the space above for future reference.

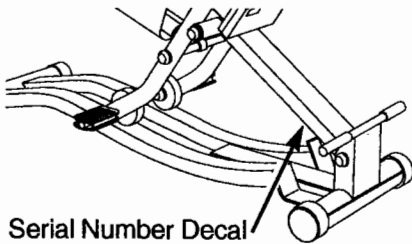

EXERCISE
EQUIPMENT

QUESTIONS

HELPLINE!

1-800-736-6879

Patent Pending

CAUTION

Read all precautions and instructions in this manual before using this equipment. Keep this manual for future reference.

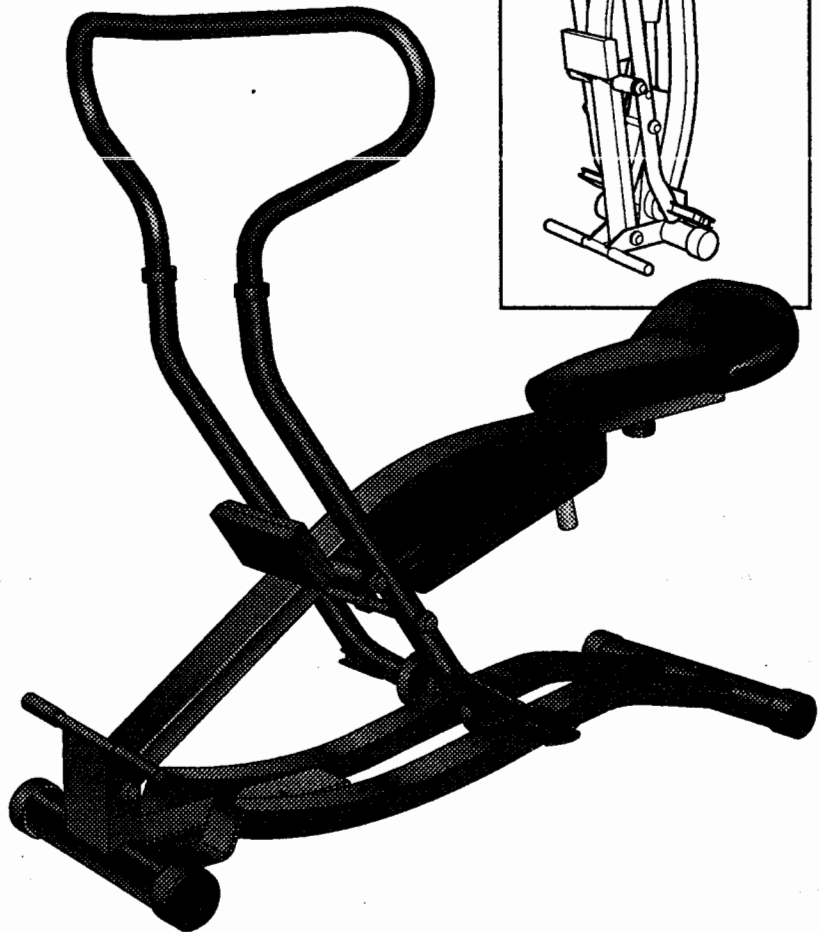
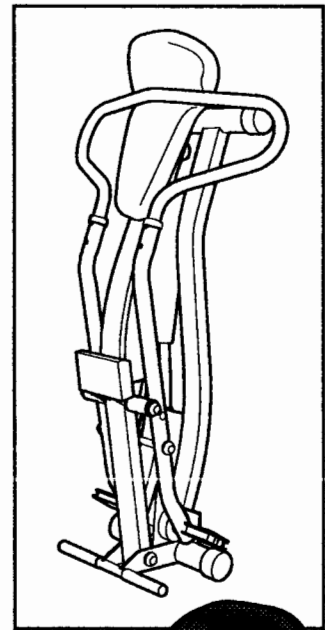

SEARS, ROEBUCK AND CO., HOFFMAN ESTATES, IL 60179

TABLE OF CONTENTS

IMPORTANT PRECAUTIONS	2
BEFORE YOU BEGIN	3
ASSEMBLY	4
HOW TO USE THE R-930	5
MAINTENANCE AND STORAGE	7
CONDITIONING GUIDELINES	8
PART LIST	10
EXPLODED DRAWING	11
ORDERING REPLACEMENT PARTS	.Back Cover
FULL 90 DAY WARRANTY	.Back Cover

IMPORTANT PRECAUTIONS

WARNING: To reduce the risk of serious injury, read the following important precautions before using the PROFORM® R-930.

1. It is the responsibility of the owner to ensure that all users of the R-930 are adequately informed of all precautions.
2. Read all instructions in this manual before using the R-930. Use the R-930 only as described.
3. Position the R-930 on a level surface. Place a mat beneath the R-930 to protect the floor or carpet.
4. Inspect and tighten all parts regularly. Replace any worn parts immediately.
5. Keep small children and pets away from the R-930 at all times.
6. The R-930 should not be used by persons weighing more than 250 pounds.
7. Wear appropriate clothing when exercising; do not wear loose clothing that could become caught on the R-930. Always wear athletic shoes for foot protection.
8. After adjusting the position of the seat, make sure that the seat knob is firmly retightened (see HOW TO ADJUST THE SEAT on page 5).
9. Always keep your back straight when using the R-930. Do not arch your back.
10. If you feel pain or dizziness at any time while exercising, stop immediately and begin cooling down.
11. When raising the R-930 to the vertical storage position or lowering it, hold both the handlebar and the rear tube of the frame (see HOW TO STORE THE R-930 on page 7).
12. When storing the R-930 in the vertical position, make sure that the R-930 is resting on a level surface, and that the side with the crossbar is against a wall for stability.
13. The R-930 is intended for in-home use only. Do not use the R-930 in any commercial, rental, or institutional setting.

WARNING: Before beginning this or any exercise program, consult your physician. This is especially important for persons over the age of 35 or persons with pre-existing health problems. Read all instructions before using. SEARS assumes no responsibility for personal injury or property damage sustained by or through the use of this product.

BEFORE YOU BEGIN

Thank you for selecting the innovative PROFORM® R-930. The R-930 offers a unique form of low-impact exercise that works both the upper body and the lower body for greater cardiovascular benefits and increased muscle toning. The R-930 features independent push and pull resistance controls that let you tailor your exercise to the level that's perfect for you. And when you're not exercising, the R-930 can be folded for compact storage.

For your benefit, read this manual carefully before you use the PROFORM® R-930. If you have addition-

al questions, please call our toll-free HELPLINE at 1-800-736-6879, Monday through Saturday, 7 a.m. until 7 p.m. Central Time (excluding holidays). To help us assist you, please note the product model number and serial number before calling. The model number is 831.287750. The serial number can be found on a decal attached to the R-930 (see the front cover of this manual for the location of the decal).

Before reading further, please look at the drawing below and familiarize yourself with the parts that are labeled.

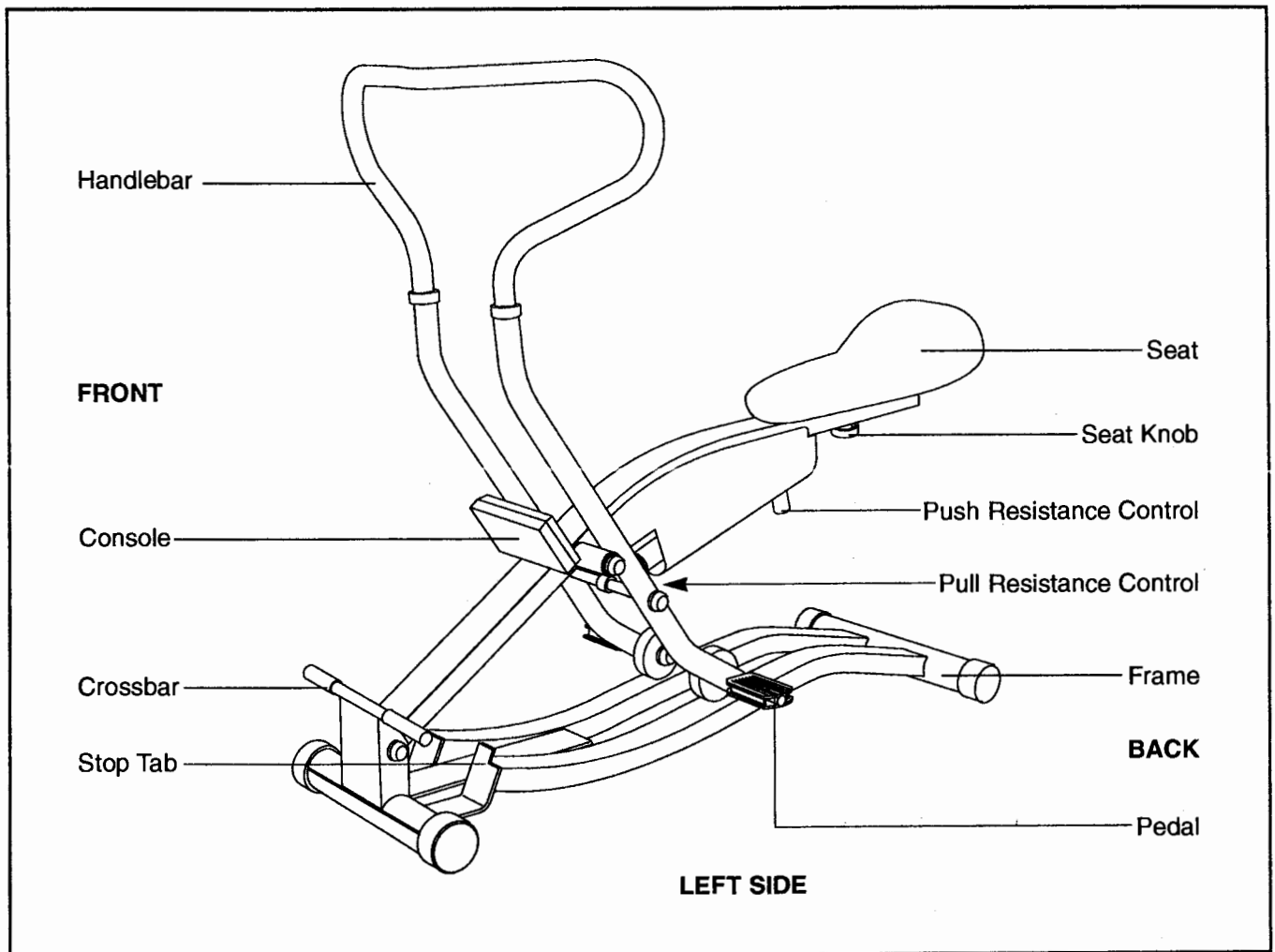

ASSEMBLY

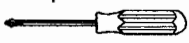
Place all parts of the R-930 in a cleared area and remove the packing materials; do not dispose of the packing materials until assembly is completed. **Assembly requires a phillips screwdriver**  (not included).

1. Firmly hold the Seat Tube (2) with one hand and the Handlebar Frame (3) with the other hand. Lift the Seat Tube and pivot the Handlebar Frame to the position shown at the right.

Make sure that there are two Handlebar Bushings (41) in the upper end of the Handlebar Frame (3). Slide the Handlebar (4) into the Handlebar Frame. The Handlebar must be turned as shown. Tighten the four #8 x 1/2" Screws (35) into the Handlebar Frame and the Handlebar.

Pivot the Console Bracket (12) to the position shown.

Push the Resistance Knob (6) onto the shaft on the Resistance Cylinder (5).

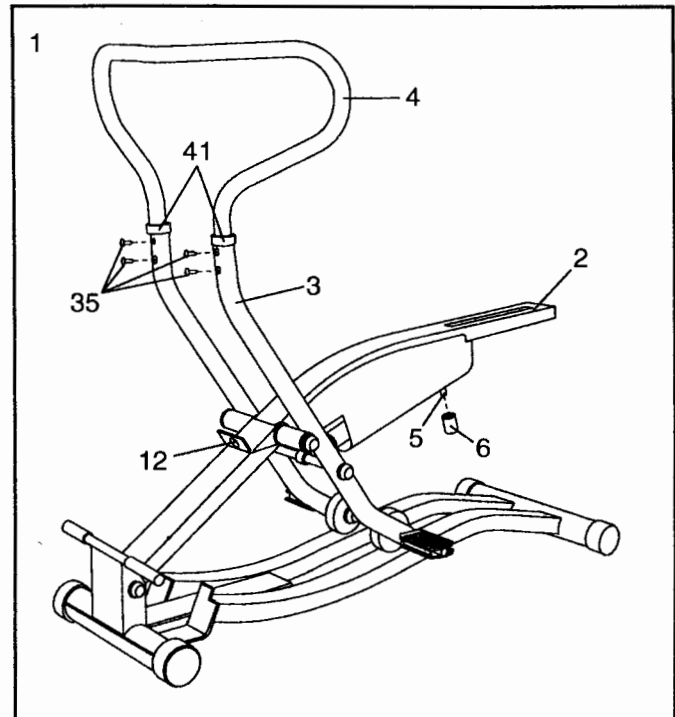

2. Locate the Carriage Bolt (9) attached to the underside of the Seat (7). Insert the Carriage Bolt down into the slot in the Seat Frame (2). Thread the Seat Knob (11) with the 3/8" Washer (42) onto the Carriage Bolt. Slide the Seat to the desired position and tighten the Seat Knob.

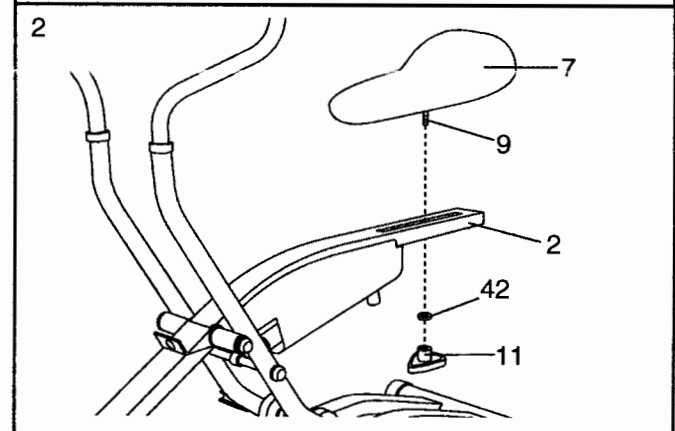

3. The Console (13) requires two "AA" batteries (not included). Alkaline batteries are recommended. See the inset drawing. Open the battery cover on the back of the Console. Insert two batteries into the Console. **Make sure that the negative (-) ends of the batteries are touching the springs in the Console.** Close the battery cover.

Connect the Reed Switch Wire (33) to the wire on the Console (13). Feed any excess wire into the Seat Frame (2). Insert the Console into the Console Bracket (12) until the tab on the Console snaps into the hole in the Console Bracket.

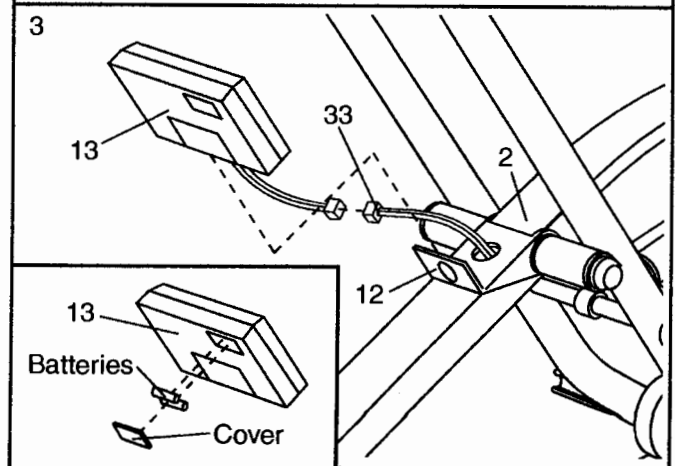

HOW TO USE THE R-930

HOW TO ADJUST THE SEAT

To adjust the position of the Seat (7), first turn the Seat Knob (11) to loosen it. Slide the Seat to the desired position and **firmly retighten the Seat Knob**.

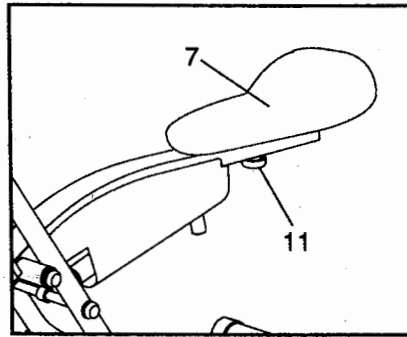

HOW TO ADJUST THE PULL RESISTANCE

The unique R-930 allows you to adjust the push and pull resistance levels independently. To change the resistance you feel when you pull the handlebar, turn the collar at the front of the Resistance

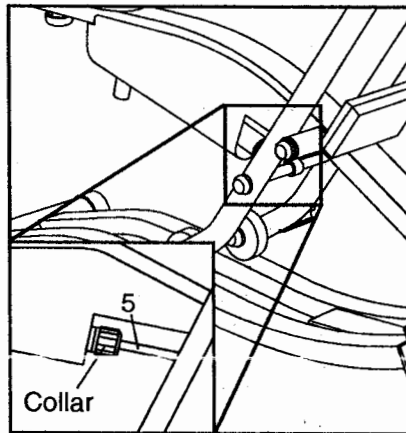

Cylinder (5). There are twelve different resistance levels. A small arrow on the right side shield will show which resistance level is selected.

HOW TO ADJUST THE PUSH RESISTANCE

To change the resistance you feel as you push the handlebar, turn the Knob (6) at the back of the Resistance

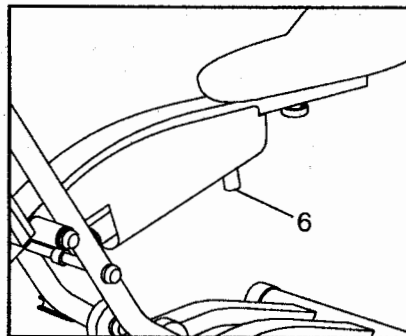

HOW TO EXERCISE ON THE R-930

Sit on the Seat (7), place your feet on the Pedals (14), and hold the Handlebar (4). Your hands can be positioned on the top, sides, or bottom of the Handlebar, close together or far apart, or in an overhand or underhand grip. If necessary, adjust the position of the Seat.

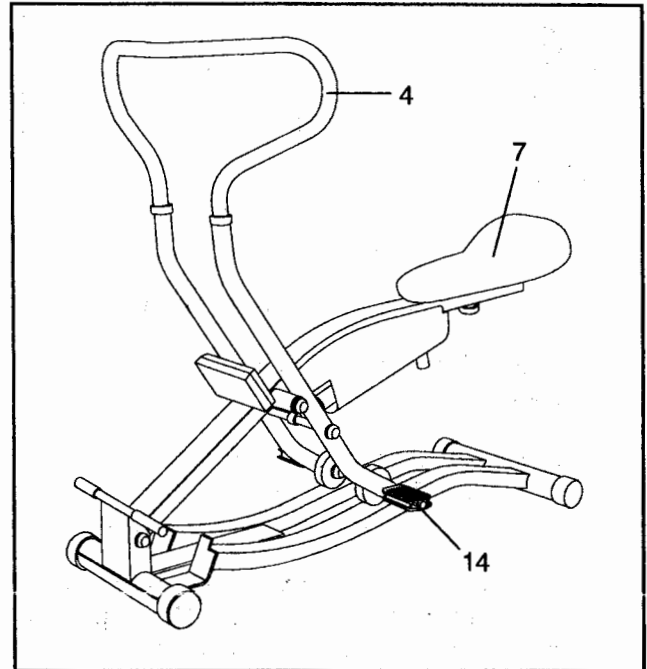

To begin exercising, pull the Handlebar (4) toward your waist while pushing the Pedals (14) away with your legs. Return to the starting position. This completes one repetition. Repeat, moving with a smooth, continuous motion. For the best results, move through the full range of motion and maintain a steady pace. **CAUTION: To avoid injury, keep your back straight. Do not arch your back.** As you exercise, adjust the push and pull resistance levels as desired.

Note: The console will automatically turn on when you begin exercising on the R-930. The operation of the console is described on page 6.

DESCRIPTION OF THE CONSOLE

The console features five modes that provide instant exercise feedback during your workouts. The modes are described below.

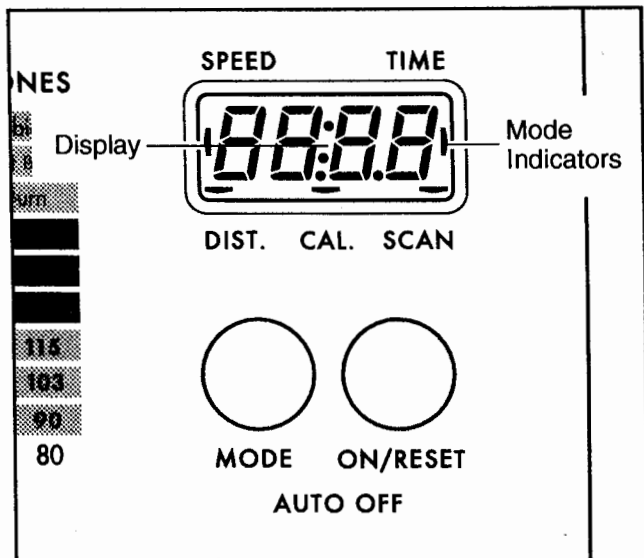

- Speed—Displays your speed, in repetitions per minute.
- Time—Displays the length of time you have exercised. Note: If you stop exercising for ten seconds or longer, the time mode will pause until you resume.
- Distance—Displays the total number of repetitions you have completed, up to 999. The display will then reset to zero and continue counting.
- Calorie—Displays the approximate number of Calories you have burned.
- Scan—Displays the speed, time, distance, and calorie modes, for 5 seconds each, in a repeating cycle.

BATTERY INSTALLATION

Before the console can be operated, two “AA” batteries must be installed. If you have not installed batteries, see assembly step 3 on page 4.

HOW TO OPERATE THE CONSOLE

1. To turn on the power, press the on/reset button or simply begin exercising on the R-930. When the power is turned on, the entire display will appear for two seconds. The console will then be ready for operation.

2. Select one of the five modes:

Scan mode—When the power is turned on, the scan mode will automatically be selected. One mode indicator will

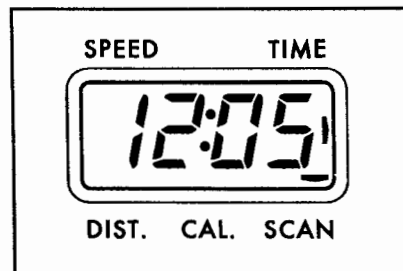

show that the scan mode is selected, and a flashing mode indicator will show which mode is currently displayed. Note: If a different mode is selected, you can select the scan mode again by repeatedly pressing the mode button.

Speed, time, distance or calorie mode—To select one of these modes for continuous display, repeatedly press the mode button. The mode indicators will show which mode is selected. (Make sure that the scan mode is not selected.)

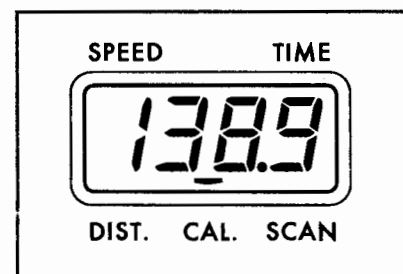

3. To reset the display, press the on/reset button.

4. To turn off the power, simply wait for about four minutes. **Note: The console has an “auto-off” feature. If the pedals are not moved and the console buttons are not pressed for four minutes, the power will turn off automatically in order to conserve the batteries.**

MAINTENANCE AND STORAGE

Inspect and tighten all parts of the R-930 regularly. Clean the R-930 periodically with a soft, damp cloth. To prevent damage to the console, keep liquids away from the console and keep the console out of direct sunlight.

HOW TO LUBRICATE THE R-930

Every three months, a small amount of light multi-purpose oil should be applied to the R-930. Apply a few drops of oil between the dome caps and the frame in the locations shown at the right. Be sure to apply oil to both sides of the R-930.

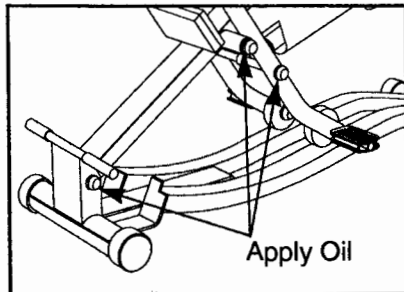

HOW TO ADJUST THE REED SWITCH

If the console does not operate properly, the batteries should be replaced. See assembly step 3 on page 4 for installation instructions.

If the console does not display correct feedback, the position of the Reed Switch (33) should be adjusted. Loosen, but do not remove, the two indicated #8 x 1/2" Screws (35). Slide the Screws 1/8" to the left or right, making sure to keep the upper Screw directly above the lower Screw. **Make sure that the lever on the Reed Switch is behind the indicated tab.** Tighten the Screws. Exercise on the R-930 for a moment. Repeat until the console displays correct feedback.

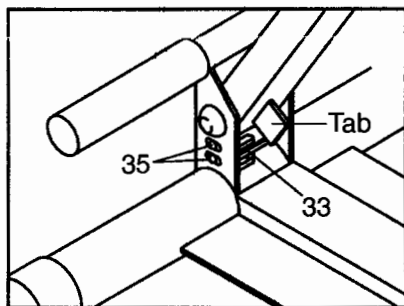

HOW TO STORE THE R-930

When the R-930 is not in use, it can be folded for compact storage. Follow the steps at the right to fold the R-930. Note: If the seat is near the rear of the seat frame, the R-930 cannot be folded. If necessary, move the seat forward before folding the R-930 (see HOW TO ADJUST THE SEAT on page 5).

1. Hold the Handlebar (4) firmly and pivot it back and down until the Wheel (26) hits the stop tab. Next, lift the Seat (7) slightly and continue to pivot the Handlebar down until the R-930 is in the position shown in drawing 1a. Fold down the Console (13).

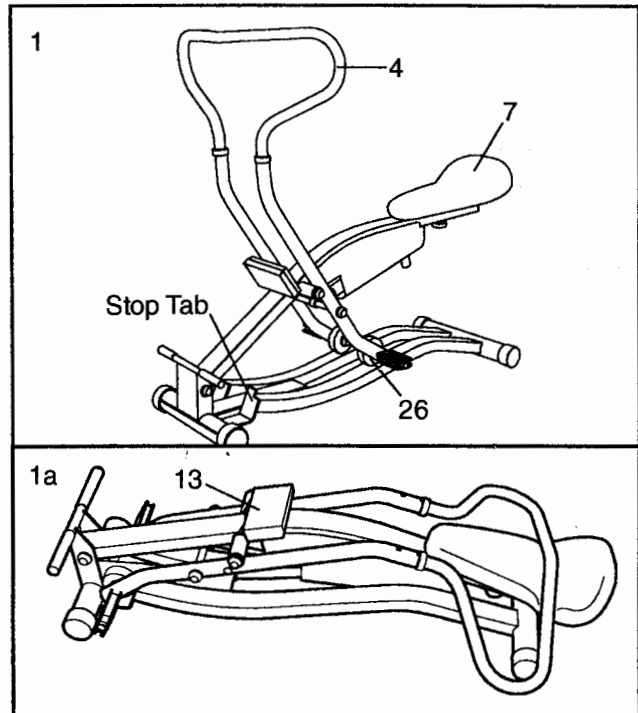

2. If desired, the R-930 can be stored in a vertical position. Fold the R-930 as described above. Next, **firmly hold the Handlebar (4) with one hand, and hold the rear tube of the Frame (1) with the other hand.** Raise the R-930 to the position shown at the right. **Make sure that the R-930 is resting on a level surface, and that the side with the crossbar is against a wall for stability.**

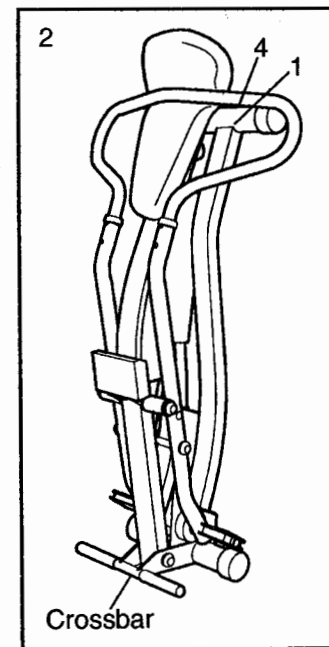

To set up the R-930 for use, follow the steps above in reverse order. **When lowering the R-930 from the vertical storage position, remember to hold both the handlebar and the rear tube of the frame.**

CONDITIONING GUIDELINES

The following general guidelines will help you to plan your exercise program. Remember that proper nutrition and adequate rest are essential for successful results.

WARNING: Before beginning this or any exercise program, consult your physician. This is especially important for persons over the age of 35 or persons with pre-existing health problems.

EXERCISE INTENSITY

Whether your goal is to burn fat or strengthen your cardiovascular system, the key to achieving the desired results is to exercise with the proper intensity. The proper intensity level can be found by using your heart rate as a guide. The chart below shows recommended heart rates for fat burning, maximum fat burning, and cardiovascular (aerobic) exercise.

BPM	HEART RATE TRAINING ZONES						
165						Aerobic	
145	143					Max Fat Burn	
125	122	119				Fat Burn	
	130	130	140				
		115	125	130			
			110	118	125		
				105	110	115	
					95	100	
						90	
Age	20	30	40	50	60	70	80

To find the proper heart rate for you, first find your age near the bottom of the chart (ages are rounded off to the nearest ten years). Next, look above your age and find the three numbers in light grey boxes. The three numbers are your "training zone." The lowest number is the recommended heart rate for fat burning; the middle number is the recommended heart rate for maximum fat burning; the highest number is the recommended heart rate for aerobic exercise.

Fat Burning

To burn fat effectively, you must exercise at a relatively low intensity level for a sustained period of time. During the first few minutes of exercise, your body uses easily accessible *carbohydrate* calories for energy. Only after the first few minutes of exercise does

your body begin to use stored *fat* calories for energy. If your goal is to burn fat, adjust your pace until your heart rate is near the lowest number in your training zone as you exercise. It may also be helpful to set the collar at the front of the resistance cylinder to level 1, 2, 3, or 4.

For maximum fat burning, adjust your pace until your heart rate is near the middle number in your training zone as you exercise.

Aerobic Exercise

If your goal is to strengthen your cardiovascular system, your exercise must be "aerobic." Aerobic exercise is activity that requires large amounts of oxygen for prolonged periods of time. This increases the demand on the heart to pump blood to the muscles, and on the lungs to oxygenate the blood. For aerobic exercise, adjust your pace until your heart rate is near the highest number in your training zone. It may also be helpful to set the collar at the front of the resistance cylinder to level 5, 6, 7, or 8.

Strength Training

To strengthen and tone your muscles, you must exercise your muscles at a moderate to high percentage of their capacity. Set the collar at the front of the resistance cylinder to level 9, 10, 11, or 12.

HOW TO MEASURE YOUR HEART RATE

To measure your heart rate, first exercise for at least four minutes. Then, stop exercising and place two fingers on your wrist as shown. Take a six-second heartbeat count, and

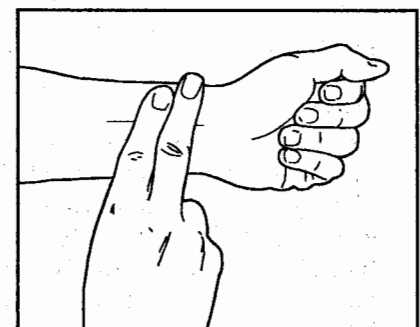

multiply the result by 10 to find your heart rate. For example, if your six-second heartbeat count is 14, your heart rate is 140 beats per minute. (A six-second count is used because your heart rate will drop rapidly when you stop exercising.)

Adjust the intensity of your exercise until your heart rate is at the desired level. You can adjust the intensity of your exercise by adjusting the resistance or by changing your pace.

WORKOUT GUIDELINES

Each workout should include the following three parts:

A warm-up, lasting 5 to 10 minutes. Begin with slow, controlled stretches, and progress to more rhythmic stretches to increase the body temperature, heart rate, and circulation in preparation for strenuous exercise.

Training zone exercise, consisting of 20 to 30 minutes of exercising with your heart rate in your training zone.

A cool-down, with 5 to 10 minutes of stretching. Thorough stretching helps to offset problems caused

when you stop exercising suddenly. Stretching for increased flexibility is also most effective after exercising. A proper cool-down should leave you relaxed and comfortably tired.

EXERCISE FREQUENCY

To maintain or improve your condition, plan three workouts each week, with at least one day of rest between workouts. After a few months of regular exercise, you may complete up to five workouts each week, if desired.

Remember, the key to success is make exercise a regular and enjoyable part of your everyday life.

SUGGESTED STRETCHES

The correct form for several basic stretches is shown in the drawings below. Move slowly as you stretch—never bounce.

1. Toe Touch Stretch

Stand with your knees bent slightly and slowly bend forward from your hips. Allow your back and shoulders to relax as you reach down toward your toes as far as possible. Hold for 15 counts, then relax. Repeat 3 times. Stretches: Hamstrings, back of knees and back.

2. Hamstring Stretch

Sit with one leg extended. Bring the sole of the opposite foot toward you and rest it against the inner thigh of your extended leg. Reach toward your toes as far as possible. Hold for 15 counts, then relax. Repeat 3 times for each leg. Stretches: Hamstrings, lower back and groin.

3. Calf/Achilles Stretch

With one leg in front of the other, reach forward and place your hands against a wall. Keep your back leg straight and your back foot flat on the floor. Bend your front leg, lean forward and move your hips toward the wall. Hold for 15 counts, then relax. Repeat 3 times for each leg. To cause further stretching of the achilles tendons, bend your back leg as well. Stretches: Calves, achilles tendons and ankles.

4. Quadriceps Stretch

With one hand against a wall for balance, reach back and grasp one foot with your other hand. Bring your heel as close to your buttocks as possible. Hold for 15 counts, then relax. Repeat 3 times for each leg. Stretches: Quadriceps and hip muscles.

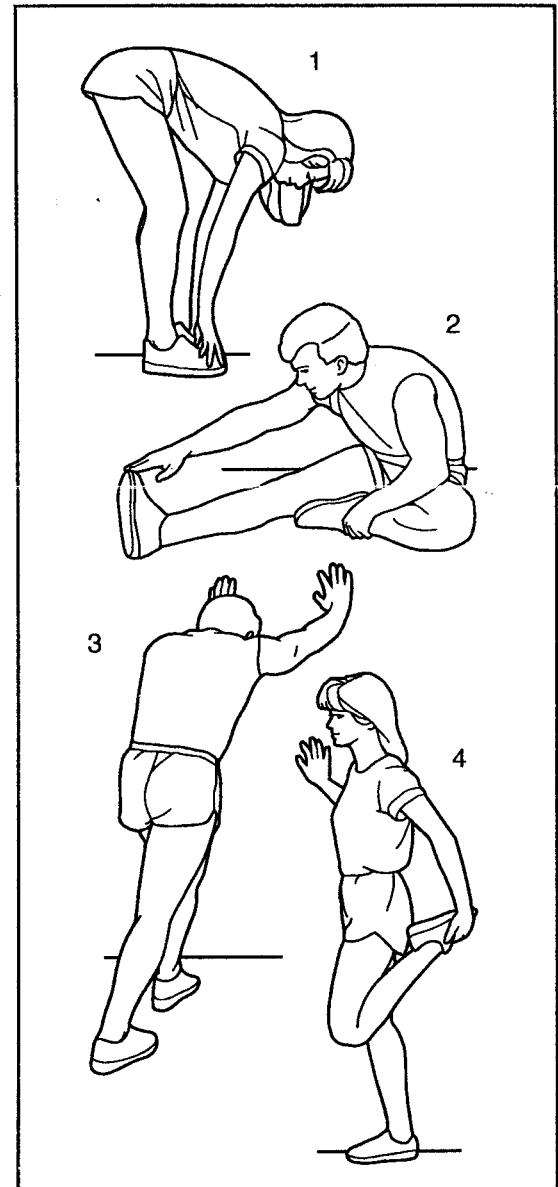

PART LIST—Model No. 831.287750

R1096A

Key No.	Part No.	Qty.	Description	Key No.	Part No.	Qty.	Description
1	NSP	1	Frame	23	106697	2	3" Wheel
2	132475	1	Seat Frame	24	130656	2	Stabilizer Endcap
3	132499	1	Handlebar Frame	25	103903	10	Dome Cap
4	131384	1	Handlebar	26	131482	2	3 1/2" Wheel
5	132500	1	Resistance Cylinder	27	131981	1	Storage Clip
6	131319	1	Resistance Knob	28	110576	4	Bronze Pivot Bushing
7	130922	1	Seat	29	131412	4	Plastic Pivot Bushing
8	130924	1	Seat Bracket	30	110722	1	1 1/2" x 3" Inner Cap
9	129187	1	Carriage Bolt	31	132600	1	Latch Plate
10	131483	2	Seat Bracket Screw	32	126047	1	Seat Spacer
11	130336	1	Seat Knob	33	132476	1	Reed Switch w/Wire
12	130926	1	Console Bracket	34	012155	4	1/2" Push Nut
13	130165	1	Console	35	013162	6	#8 x 1/2" Screw
14	126406	2	Pedal	36	127597	3	Fastener
15	131409	1	Left Side Shield	37	131842	2	Grip
16	132502	1	Right Side Shield	38	132264	1	Reed Switch Bracket
17	130659	4	Side Shield Fastener	39	126845	1	1" Plastic Grommet
18	132497	1	1/2" x 5" Axle	40	014080	2	Washer
19	132498	2	1/2" x 10 3/4" Axle	41	128794	2	Handlebar Bushing
20	131411	2	Plastic Wheel Bushing	42	014156	1	3/8" Washer
21	128485	1	1/2" x 2" Axle	43	013186	1	1/4" x 1" Screw
22	131410	1	0.312" x 16" Axle	#	132037	1	User's Manual

Note: "#" indicates a non-illustrated part. Specifications are subject to change without notice. See the back cover of this manual for information about ordering replacement parts.

EXPLODED DRAWING—Model No. 831.287750

R1096A

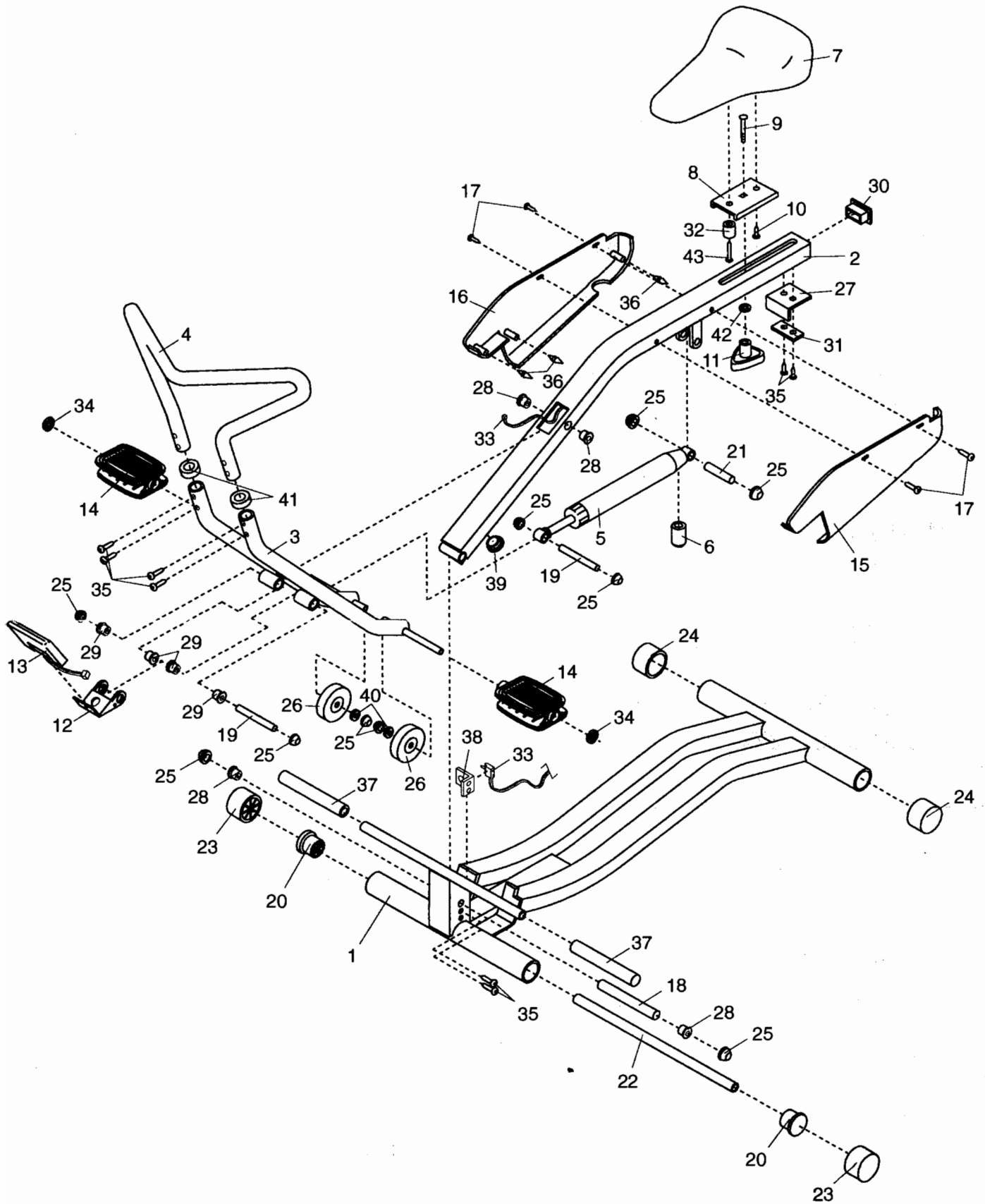

SEARS

Model No. 831.287750

QUESTIONS?

If you find that:

- you need help assembling or operating the PROFORM® R-930
- a part is missing
- or you need to schedule repair service

call our toll-free HELPLINE

1-800-736-6879

Monday–Saturday, 7 am–7 pm
Central Time (excluding holidays)

REPLACEMENT PARTS

If parts become worn and need to be replaced, call the following toll-free number

1-800-FON-PART
(1-800-366-7278)

The model number and serial number of your PROFORM® R-930 are listed on a decal attached to the frame. See the front cover of this manual to find the location of the decal.

All replacement parts are available for immediate purchase or special order when you visit your nearest SEARS Service Center. To request service or to order parts by telephone, call the toll-free numbers listed at the left.

When requesting help or service, or ordering parts, please be prepared to provide the following information:

- The NAME OF THE PRODUCT (PROFORM® R-930)
- The MODEL NUMBER OF THE PRODUCT (831.287750)
- The PART NUMBER OF THE PART (see page 10 of this manual)
- The DESCRIPTION OF THE PART (see page 10 of this manual)

FULL 90 DAY WARRANTY

For 90 days from the date of purchase, if failure occurs due to defect in material or workmanship in this SEARS CARDIO FIT EXERCISER, contact the nearest SEARS Service Center throughout the United States and SEARS will repair or replace the CARDIO FIT EXERCISER, free of charge.

This warranty does not apply when the CARDIO FIT EXERCISER is used commercially or for rental purposes.

This warranty gives you specific legal rights, and you may also have other rights which vary from state to state.

SEARS, ROEBUCK AND CO., DEPT. 817WA, HOFFMAN ESTATES, IL 60179