

PRO-FORM[®] 928L

PERFORMANCE CYCLE

USER'S MANUAL

Model No. 831.288222

Serial No _____

The serial number is found in the location shown below. Write the serial number in the space above.

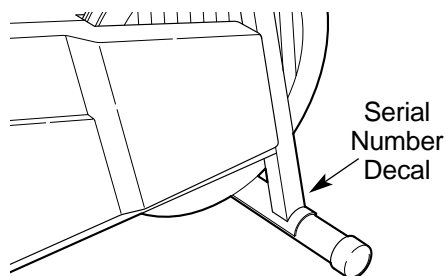

EXERCISE
EQUIPMENT

QUESTIONS

HELPLINE!

1-800-736-6879

SEARS, ROEBUCK AND CO.,
HOFFMAN ESTATES, IL 60179

CAUTION

Read all precautions and instructions in this manual before using this equipment. Keep this manual for future reference.

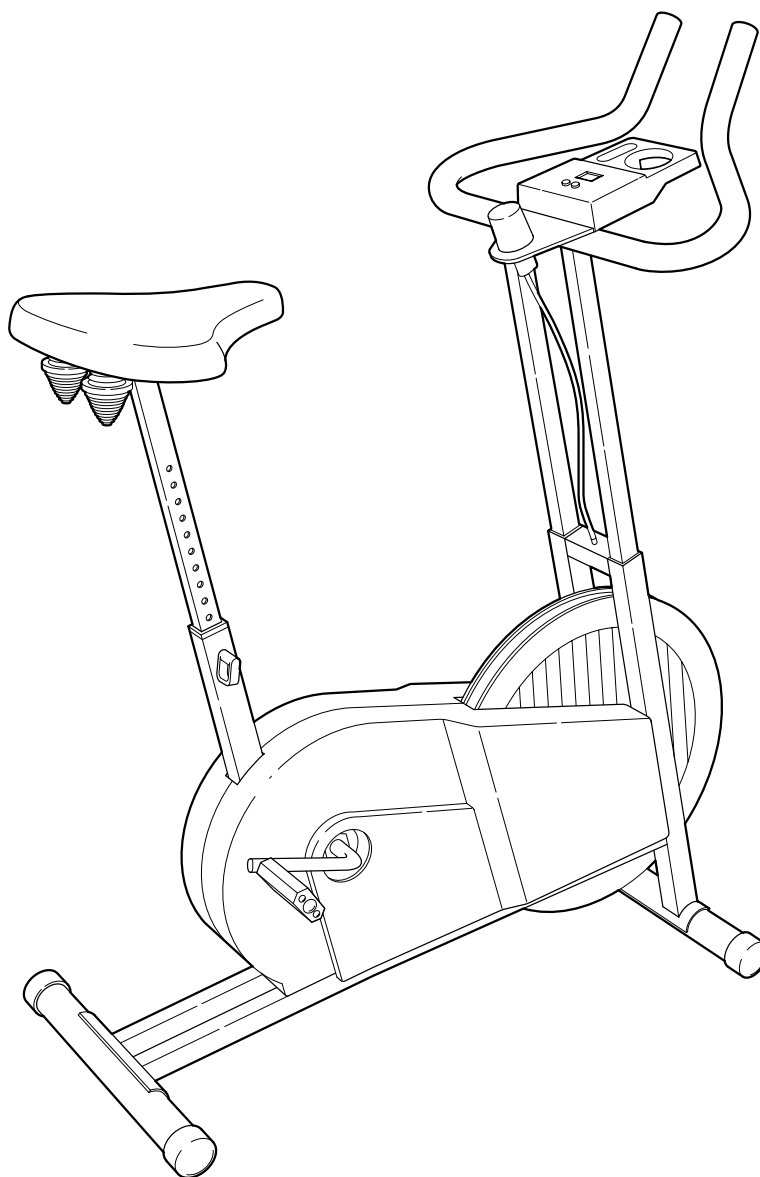

Visit our website at

www.proform.com

*new products, prizes,
fitness tips, and much more!*

TABLE OF CONTENTS

IMPORTANT PRECAUTIONS	.2
BEFORE YOU BEGIN	.3
ASSEMBLY	.4
HOW TO USE THE EXERCISE CYCLE	.6
STORAGE AND TROUBLE-SHOOTING	.7
CONDITIONING GUIDELINES	.9
PART LIST	.10
EXPLODED DRAWING	.11
HOW TO ORDER REPLACEMENT PARTS	.Back Cover
FULL 90 DAY WARRANTY	.Back Cover

IMPORTANT PRECAUTIONS

⚠ WARNING: To reduce the risk of serious injury, read the following important precautions before using the exercise cycle.

1. Read all instructions in this manual before using the exercise cycle. Use the exercise cycle only as described.
2. It is the responsibility of the owner to ensure that all users of the exercise cycle are adequately informed of all precautions.
3. Use the exercise cycle indoors, away from moisture and dust. Place the exercise cycle on a level surface, with a mat beneath it to protect the floor or carpet from damage.
4. Inspect and tighten all parts regularly. Replace any worn parts immediately.
5. Make sure the seat pin is inserted completely into the frame and the seat post. Do not insert the seat pin under the seat post.
6. Keep children under the age of 12 and pets away from the exercise cycle at all times.
7. The exercise cycle should not be used by persons weighing more than 250 pounds.
8. Wear appropriate clothing when exercising; do not wear loose clothing that could become caught on the exercise cycle. Always wear athletic shoes for foot protection.
9. Keep hands away from the flywheel and other moving parts.
10. Always keep your back straight when using the exercise cycle. Do not arch your back.
11. If you feel pain or dizziness while exercising, stop immediately and begin cooling down.
12. The exercise cycle is intended for in-home use only. Do not use the exercise cycle in a commercial, rental, or institutional setting.
13. The exercise cycle does not have a free-wheel; the pedals will continue to move until the flywheel stops.
13. The decal shown at the right has been placed on the exercise cycle. If the decal is missing, or if it is not legible, please call our toll-free HELPLINE at 1-800-736-6879 to order a free replacement decal. Apply the decal in the location shown.

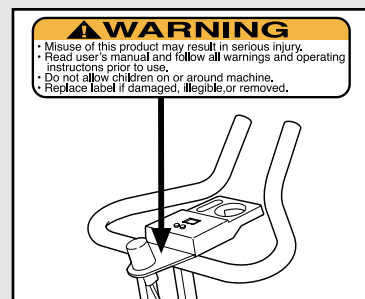

⚠ WARNING: Before beginning this or any exercise program, consult your physician. This is especially important for persons over the age of 35 or persons with pre-existing health problems. Read all instructions before using. SEARS assumes no responsibility for personal injury or property damage sustained by or through the use of this product.

BEFORE YOU BEGIN

Thank you for selecting the new PROFORM® 928L exercise cycle. The PROFORM 928L blends advanced engineering with contemporary styling to provide you with a low-impact workout in the convenience and privacy of your own home.



For your benefit, read this manual carefully before you use the PROFORM® 928L. If you have questions after reading the manual, please call our toll-free HELPLINE at 1-800-736-6879, Monday through

Saturday, 7 a.m. until 7 p.m. Central Time (excluding holidays). To help us assist you, please mention the product model number and serial number when calling. The model number is 831.288222. The serial number can be found on a decal attached to the PROFORM® 928L (see the front cover of this manual for the location of the decal).

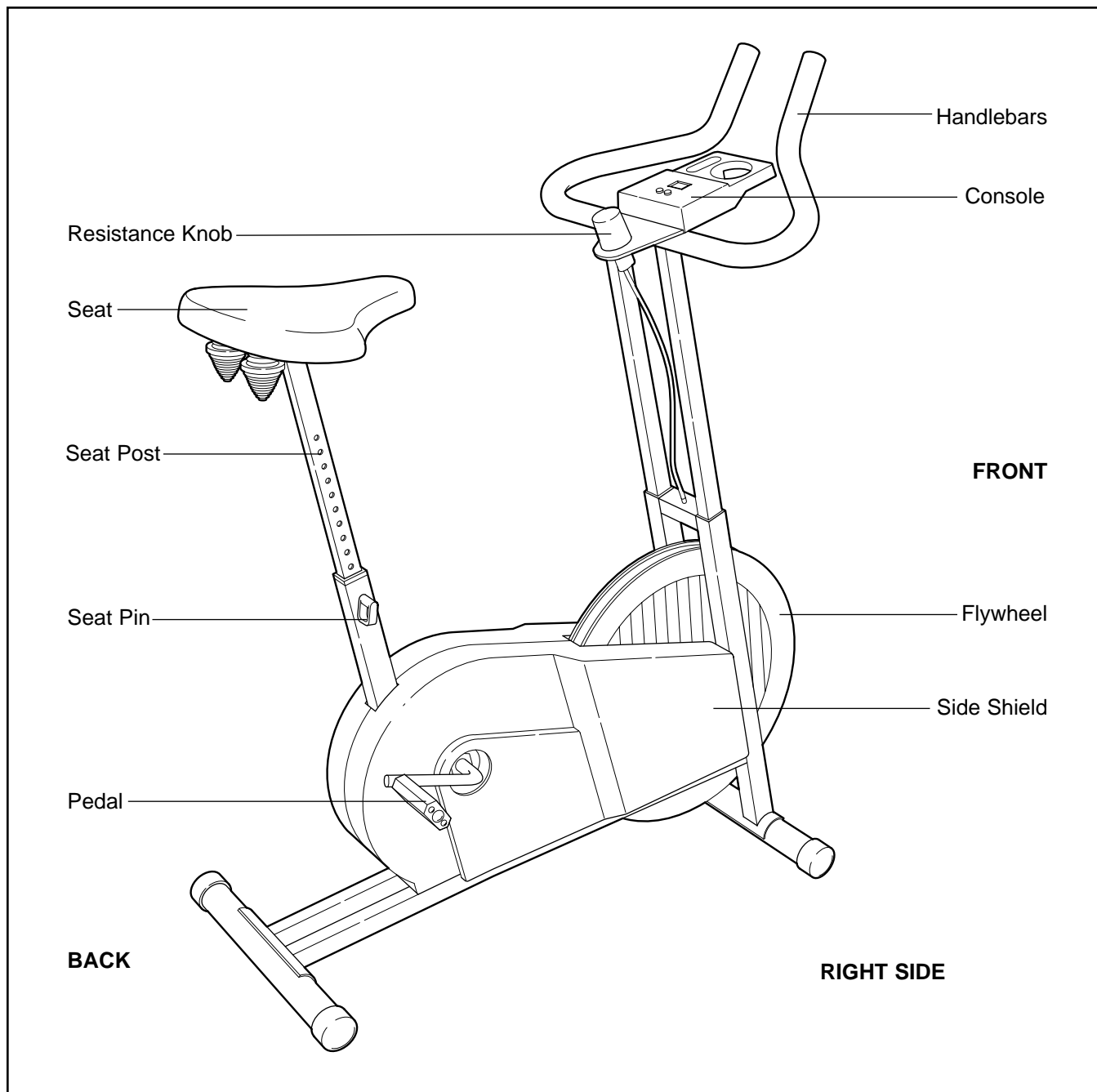
Before reading further, please familiarize yourself with the parts that are labeled in the drawing below.

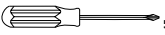

ASSEMBLY

Place all parts of the exercise cycle in a cleared area and remove the packing materials. Do not dispose of the packing materials until assembly is completed. **Assembly requires the included allen wrench** , **a phillips screwdriver** , and **two adjustable wrenches** .

1. Hold one of the Stabilizers (5) against the Frame (1), with the square holes facing away from the Frame. Attach the Stabilizer with two M8 x 65mm Carriage Bolts (38) and two M8 Nylon Locknuts (39).

Attach the other Stabilizer (not shown) in the same manner.

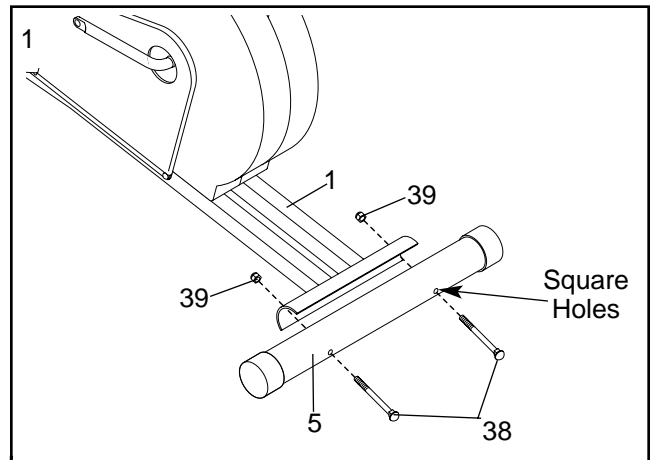

2. Hold the Handlebar Post (2) near the Frame (1) as shown. Connect the Extension Wire (37) to the Reed Switch Wire (33). Next, carefully slide the Handlebar Post down into the Frame. **Be careful not to pinch the Extension Wire or the Reed Switch Wire.** Secure the Handlebar Post with eight M4 x 16mm Tapping Screws (30).

Next, press the Resistance Knob (25) onto the end of the Resistance Cable (24). Slide the Resistance Cable into the slotted tab on the Handlebar Post (2); **make sure that the Resistance Cable is turned as shown.** Firmly push down on the Resistance Knob until the end of the Resistance Cable is fully seated in the slotted tab.

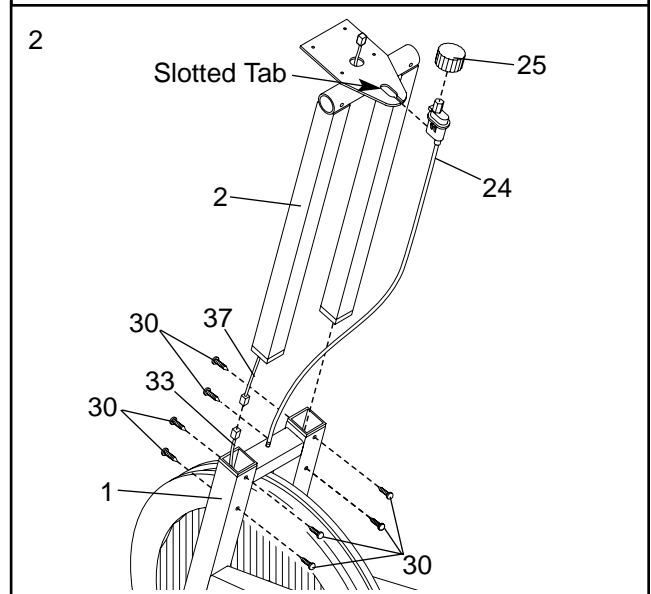

3. Slide the bottom of the Left Handlebar (3) into the Handlebar Post (2). Be sure that the holes in the Handlebar and the Handlebar Post line up. Attach the Handlebar with two M8 x 36mm Button Head Bolts (14) and two M8 Nylon Locknuts (39).

Attach the Right Handlebar (4) in the same manner.

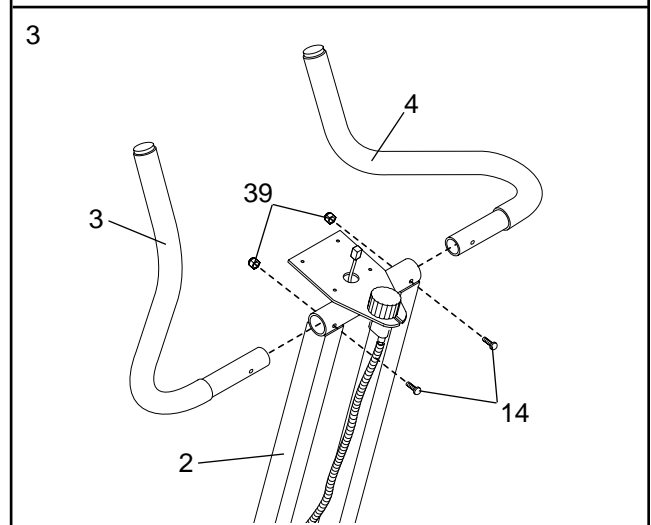

- The Console (7) requires two "AA" batteries (not included). Alkaline batteries are recommended. Refer to the inset drawing. Press two batteries into the battery compartment on the back of the console. **Make sure that the negative ends of the batteries (marked "-") are touching the springs in the battery compartment.**

Connect the console wire to the Extension Wire (37).

Attach the Console (7) to the console plate with four Console Screws (8).

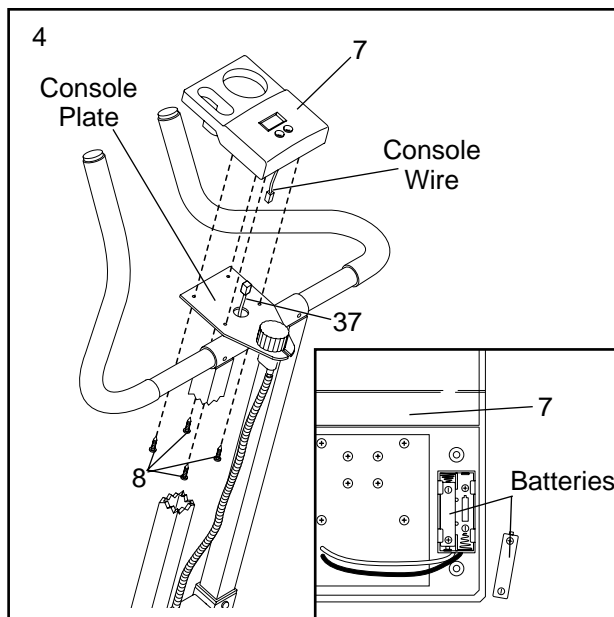

- Insert the Seat Post (10) into the Frame (1). Press the Frame Bushing (40) into the Frame. Align one of the holes in the Seat Post with the hole in the Frame. Insert the Seat Pin (35) through the Frame and the Seat Post to select the desired seat height. **Make sure to insert the Seat Pin through one of the holes in the Seat Post; do not insert the Seat Pin under the Seat Post.**

Next, attach the Seat (11) to the Seat Post (10) with one M8 x 50mm Carriage Bolt (36) and one M8 Nylon Locknut (39).

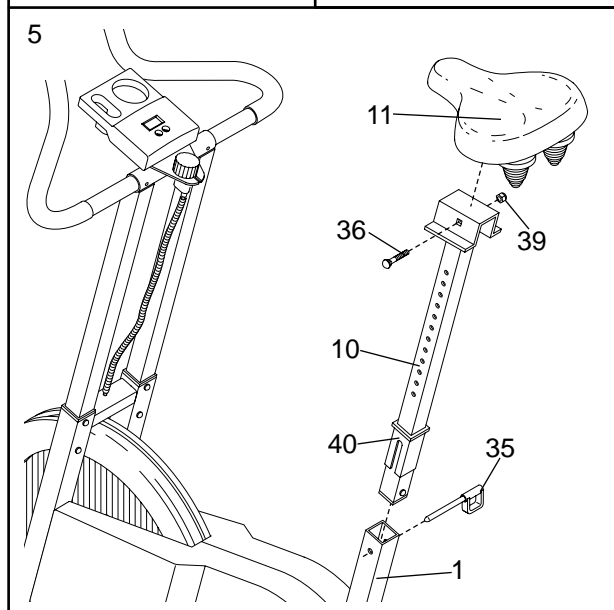

- Identify the Left Pedal (21). (The Left Pedal is marked with an "L.") Using an adjustable wrench, tighten the Left Pedal *counterclockwise* into the left arm of the Crank (20).

Tighten the Right Pedal (not shown) *clockwise* into the Right arm on the Crank.

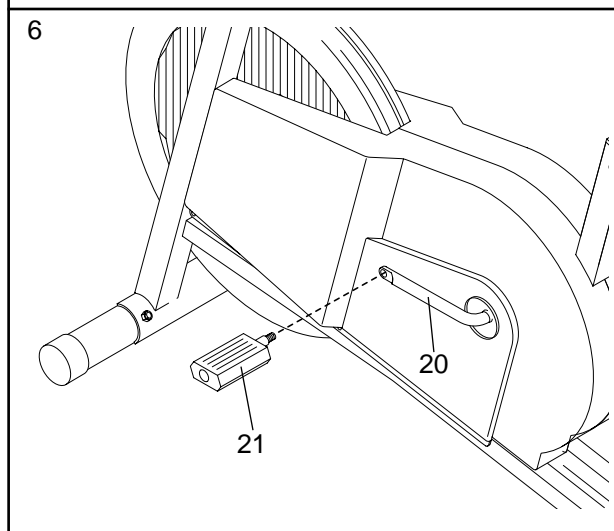

- Make sure that all parts are properly tightened before you use the exercise cycle. Note: There may be some hardware left over after assembly is completed.**

HOW TO USE THE EXERCISE CYCLE

HOW TO ADJUST THE SEAT

For effective exercise, the Seat (11) should be at the proper height. As you pedal, there should be a slight bend in your knees when the pedals are in the lowest position. To adjust the Seat, first hold the Seat and remove the Seat Pin (35). Align one of the holes in the Seat Post (10) with the hole in the Frame (1). Insert the Seat Pin into the Frame and the Seat Post. **Caution: Make sure to insert the Seat Pin through one of the holes in the Seat Post; do not insert the Seat Pin under the Seat Post.**

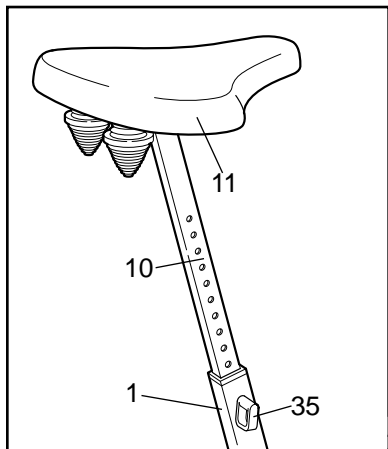

HOW TO ADJUST THE PEDALING RESISTANCE

To vary the intensity of your exercise, the pedaling resistance can be adjusted. The resistance is controlled with the Resistance Knob (25). To increase the resistance, turn the Resistance Knob clockwise; to decrease the resistance, turn the Resistance Knob counterclockwise.

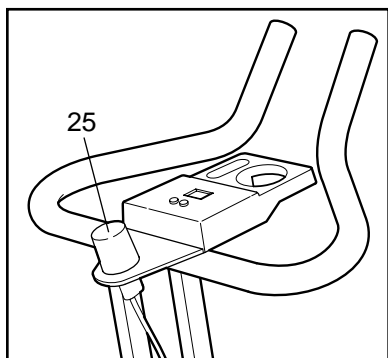

BATTERY INSTALLATION

Before the console can be operated, two "AA" batteries must be installed. If you have not installed batteries, see assembly step 4 on page 5.

DESCRIPTION OF THE CONSOLE

The console features five modes that provide instant exercise feedback during your workouts. The modes are described below.

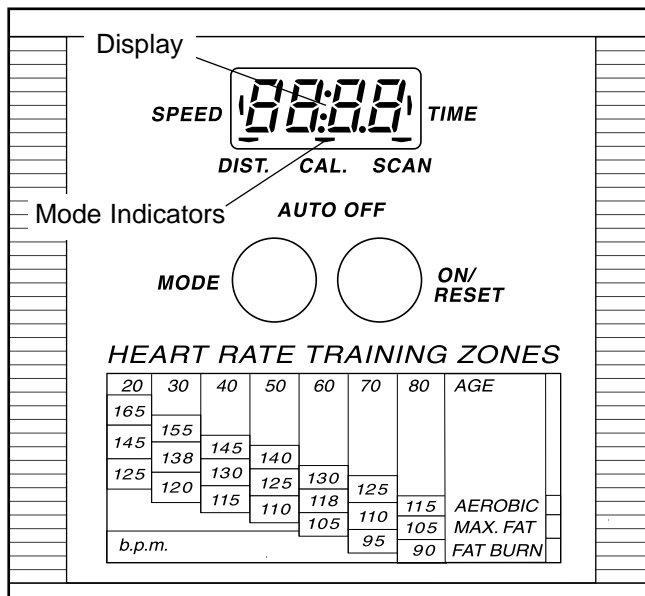

- Speed—Displays your pedaling speed, in miles per hour.
- Time—Displays the elapsed time. Note: If you stop pedaling for ten seconds or longer, the time mode will pause until you resume.
- Distance—Displays the total distance you have pedaled, in miles.
- Calorie—Displays the approximate number of calories you have burned.
- Scan—Displays the speed, time, distance, and calorie modes, for 5 seconds each, in a repeating cycle.

HOW TO OPERATE THE CONSOLE

1. To turn on the power, press the on/reset button or simply begin pedaling. When the power is turned on, the entire display will appear for two seconds. The console will then be ready for operation.

2. Select one of the five modes:

Scan mode—
When the power is turned on, the scan mode will automatically be selected. One mode indicator will show that the scan mode is selected, and a flashing mode indicator will show which mode is currently displayed. Note: If a different mode is selected, you can select the scan mode again by repeatedly pressing the mode button.

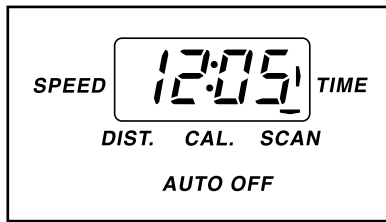

Speed, time, distance or calorie mode—To select one of these modes for continuous display, press

the mode button repeatedly. The mode indicators will show which mode is selected. Make sure that the scan mode is not selected.

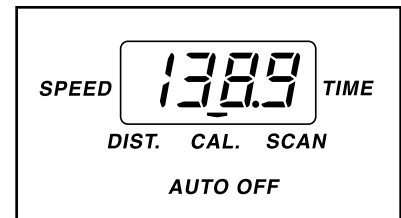

- To reset the display, press the on/reset button.
- To turn off the power, simply wait for about four minutes. **Note: The console has an “auto-off” feature. If the pedals are not moved and the console buttons are not pressed for four minutes, the power will turn off automatically in order to conserve the batteries.**

NOTE: Your console displays speed in either miles per hour (mph) or revolutions per minute (rpm). If the displayed speed has a decimal point, your console displays speed in miles per hour; if the displayed speed does not have a decimal point, your console displays speed in revolutions per minute. Use the chart below to convert one unit of measurement to the other, if desired.

RPM	10	20	30	40	50	60	70	80	90	100	110	120	130	140	150	160	170	180	190	200
MPH	2	4	6	8	10	12	14	16	18	20	22	24	26	28	30	32	34	36	38	40
KPH	3.2	6.5	9.7	13.0	16.2	19.4	22.7	25.9	29.1	32.4	35.6	38.9	42.1	45.3	48.6	51.8	55.0	58.3	61.5	64.8

If your console displays speed in miles per hour, it displays distance in *miles*. If your console displays speed in revolutions per minute, it displays distance in *total revolutions (revs)*. Use the chart below to convert one unit of measurement to the other, if desired.

REVS	300	600	900	1200	1500	1800	2100	2400	2700	3000	3300	3600	3900	4200	4500	4800	5100	5400	5700	6000
MILES	1	2	3	4	5	6	7	8	9	10	11	12	13	14	15	16	17	18	19	20
KM	1.6	3.2	4.9	6.5	8.1	9.7	11.2	12.9	14.5	16.1	17.7	19.3	21.0	22.5	24.1	25.7	27.4	29.0	30.6	32.2

STORAGE AND TROUBLE-SHOOTING

Inspect and tighten all parts of the exercise cycle regularly. Replace any worn parts immediately.

The exercise cycle can be cleaned with a soft, damp cloth. Avoid spilling liquid on the console. Keep the console out of direct sunlight or the display may be damaged. Remove the batteries when storing the exercise cycle.

HOW TO TIGHTEN THE CRANK

If the arms of the Crank (20) become loose, they should be tightened in order to prevent excessive wear. Loosen the crank nut on the left arm of the

Crank. Place the end of a standard screwdriver in one of the slots in the slotted crank nut. Lightly tap the screwdriver with a hammer to turn the slotted crank nut counter-clockwise until the arms are no longer loose. **Do not overtighten the slotted crank nut.** When the slotted crank nut is properly tightened, retighten the crank nut.

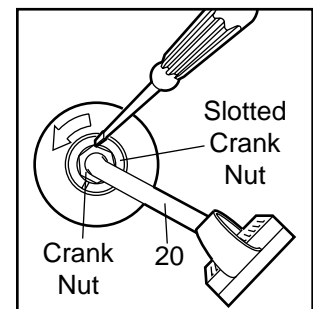

HOW TO ADJUST THE REED SWITCH

If the console does not display correct feedback, the reed switch should be adjusted. In order to adjust the reed switch, the Left Side Shield (12) must be removed. Remove the four Side Shield Screws (15) from the Right Side Shield (13) and the three M4 x 16mm Tapping Screws (30) from the bottom of the Left Side Shield. Carefully slide the Left Side Shield forward off the arm of the Crank (20) and remove it.

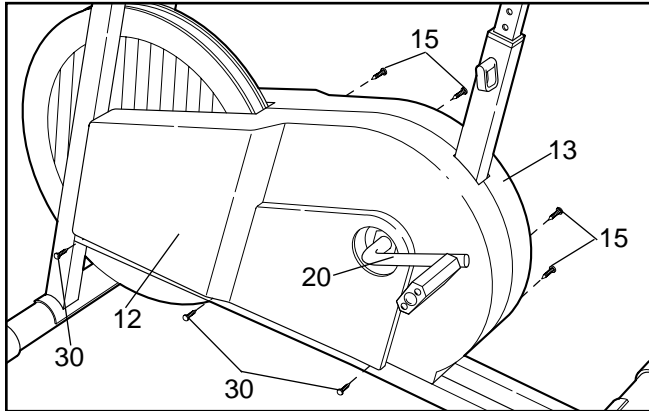

Next, locate the Reed Switch (33). Turn the crank until the Magnet (46) is aligned with the Reed Switch. Loosen but do not remove the M4 x 16mm Screw (30). Slide the Reed Switch slightly closer to or away from the Magnet. Retighten the Screw. Turn the crank for a moment. Repeat until the console displays correct feedback. When the Reed Switch is correctly adjusted, reattach the left side shield.

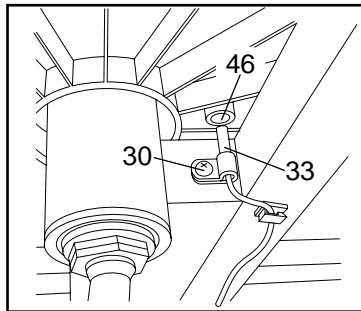

HOW TO ADJUST THE RESISTANCE STRAP

If there is not enough pedaling resistance when the resistance knob is turned to the highest setting, the Resistance Strap (17) may need to be adjusted. To adjust the Resistance Strap, first turn the resistance knob to the lowest setting. Next, locate and open the Strap Buckle (18) on the underside of the side shields. Grip the

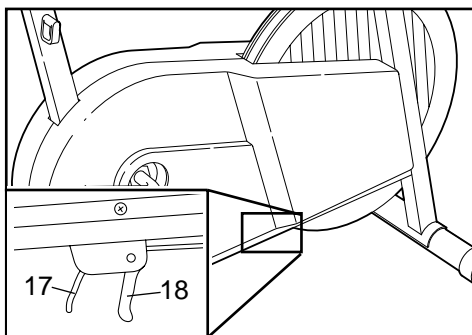

end of the Resistance Strap (17) and pull it back **slightly** to remove any slack. While holding the end of the Resistance Strap, **fully** close the Strap Buckle. Turn the crank for a moment to make sure that there is not too much resistance.

HOW TO ADJUST THE DRIVE BELT

The exercise cycle features a drive belt that must be kept properly adjusted. If the belt causes excessive noise or slips as you pedal, the belt should be checked. To do this, the side shields must first be removed. Refer to the instructions on this page and remove the left side shield. Next, remove the right side shield the same way.

Press down on the center of the Drive Belt (23) between the front and rear pulleys. **There should be from 1/4" to 1/2" of movement in the center of the Belt.**

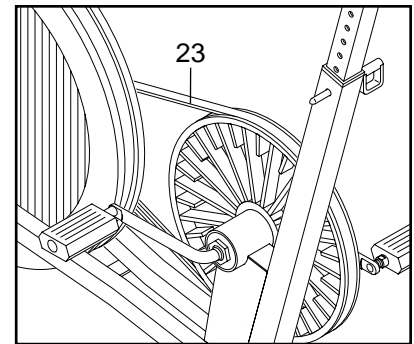

If the drive belt is properly adjusted, reattach the side shields. If the Belt needs to be adjusted, loosen the Axle Nut (29) on each side of the flywheel. To tighten the Belt, turn the Adjustment Nuts (27) clockwise; to loosen the Belt, turn the Adjustment Nuts counterclockwise. Make sure that the Flywheel is straight and tighten the Axle Nuts (29). Reattach the side shields.

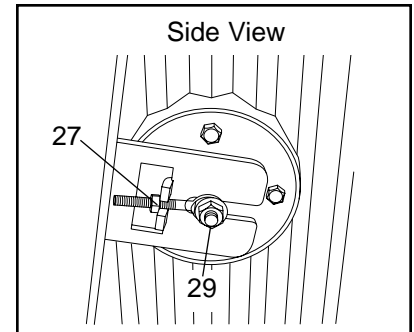

BATTERY REPLACEMENT

If the console does not function properly, the batteries should be replaced. See assembly step 4 on page 5. In addition, make sure that the console wire is connected to the reed switch wire.

CONDITIONING GUIDELINES

The following guidelines will help you to plan your exercise program. Remember that proper nutrition and adequate rest are essential for successful results.

⚠ WARNING: Before beginning this or any exercise program, consult your physician. This is especially important for persons over the age of 35 or persons with pre-existing health problems.

EXERCISE INTENSITY

Whether your goal is to burn fat or to strengthen your cardiovascular system, the key to achieving the desired results is to exercise with the proper intensity. The proper intensity level can be found by using your heart rate as a guide. The chart below shows recommended heart rates for fat burning, maximum fat

20	30	40	50	60	70	80	AGE
165							
145	155						
125	138	145	140				
	120	130	125	130	125		
		115	110	118	110	115	AEROBIC
				105	95	105	MAX. FAT
b.p.m.						90	FAT BURN

burning, and cardiovascular (aerobic) exercise. To find the proper heart rate for you, first find your age on the bottom of the chart (ages are rounded off to the nearest ten years). Next, find the three numbers above your age. The three numbers are your "training zone." The lowest number is the recommended heart rate for fat burning; the middle number is the heart rate for maximum fat burning; the highest number is the heart rate for aerobic exercise.

Burning Fat

To burn fat effectively, you must exercise at a relatively low intensity level for a sustained period of time. During the first few minutes of exercise, your body uses easily accessible *carbohydrate* calories for energy. Only after the first few minutes of exercise does your body begin to use stored *fat* calories for energy. If your goal is to burn fat, adjust the intensity of your exercise until your heart rate is near the lowest num-

ber in your training zone as you exercise. For maximum fat burning, adjust the intensity of your exercise until your heart rate is near the middle number in your training zone as you exercise.

Aerobic Exercise

If your goal is to strengthen your cardiovascular system, your exercise must be "aerobic." Aerobic exercise is activity that requires large amounts of oxygen for prolonged periods of time. This increases the demand on the heart to pump blood to the muscles, and on the lungs to oxygenate the blood. For aerobic exercise, adjust the intensity of your exercise until your heart rate is near the highest number in your training zone.

HOW TO MEASURE YOUR HEART RATE

To measure your heart rate, first exercise for at least four minutes. Then, stop exercising and place two fingers on your wrist as shown. Take a six-second heart-beat count, and multiply the result by 10 to find your heart

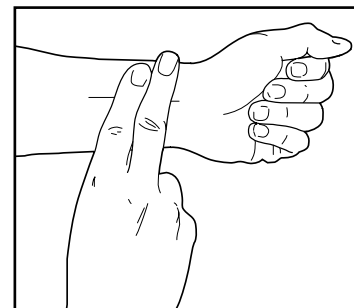

rate. For example, if your six-second heartbeat count is 14, your heart rate is 140 beats per minute. (A six-second count is used because your heart rate will drop rapidly when you stop exercising.)

WORKOUT GUIDELINES

Each workout should include the following three parts:

A warm-up, consisting of 5 to 10 minutes of stretching and light exercise. A proper warm-up increases your body temperature, heart rate, and circulation in preparation for exercise.

Training zone exercise, consisting of 20 to 30 minutes of exercising with your heart rate in your training zone. (During the first few weeks of your exercise program, do not keep your heart rate in your training zone for longer than 20 minutes.)

A cool-down, with 5 to 10 minutes of stretching. This will increase the flexibility of your muscles and will help to prevent post-exercise problems.

EXERCISE FREQUENCY

To maintain or improve your condition, plan three workouts each week, with at least one day of rest between workouts. After a few months of regular exercise, you may complete up to five workouts each week, if

desired. **Caution: Be sure to progress at your own pace and avoid overdoing it. Incorrect or excessive training may result in injury to your health.**

Remember, the key to success is make exercise a regular and enjoyable part of your everyday life.

PART LIST—Model No. 831.288222

R0400A

Key No.	Qty.	Description	Key No.	Qty.	Description
1	1	Frame	26	1	Flywheel Axle
2	1	Handlebar Post	27	2	Adjustment Nut
3	1	Left Handlebar	28	2	Adjustment Bolt
4	1	Right Handlebar	29	2	Axle Nut
5	2	Stabilizer	30	18	M4 x 16mm Tapping Screw
6	4	Stabilizer Endcap	31	1	Flat Head Screw
7	1	Console	32	2	Handlebar Endcap
8	4	Console Screw	33	1	Reed Switch/Wire
9	2	Foam Grip	34	1	Reed Switch Clip
10	1	Seat Post	35	1	Seat Pin
11	1	Seat	36	1	M8 x 50mm Carriage Bolt
12	1	Left Side Shield	37	1	Extension Cable
13	1	Right Side Shield	38	4	M8 x 65mm Carriage Bolt
14	2	M8 x 36mm Button Head Bolt	39	7	M8 Nylon Locknut
15	4	Side Shield Screw	40	3	Frame Bushing
16	1	Flywheel	41	3	Post Endcap
17	1	Resistance Strap	42	1	M4 x 14mm Bolt
18	1	Strap Buckle	43	4	M4 Washer
19	1	Crank Hardware Assembly	44	1	Spring
20	1	Crank/Pulley	45	1	M4 Nut
21	1	Left Pedal	46	1	Magnet
22	1	Right Pedal	47	2	M10 Washer
23	1	Drive Belt	#	1	User's Manual
24	1	Resistance Cable	#	1	Allen Wrench
25	1	Resistance Knob			

Note: “#” refers to a non-illustrated part. Specifications are subject to change without notice. See the back cover of this manual for information about ordering replacement parts.

EXPLODED DRAWING—Model No. 831.288222

R0400A

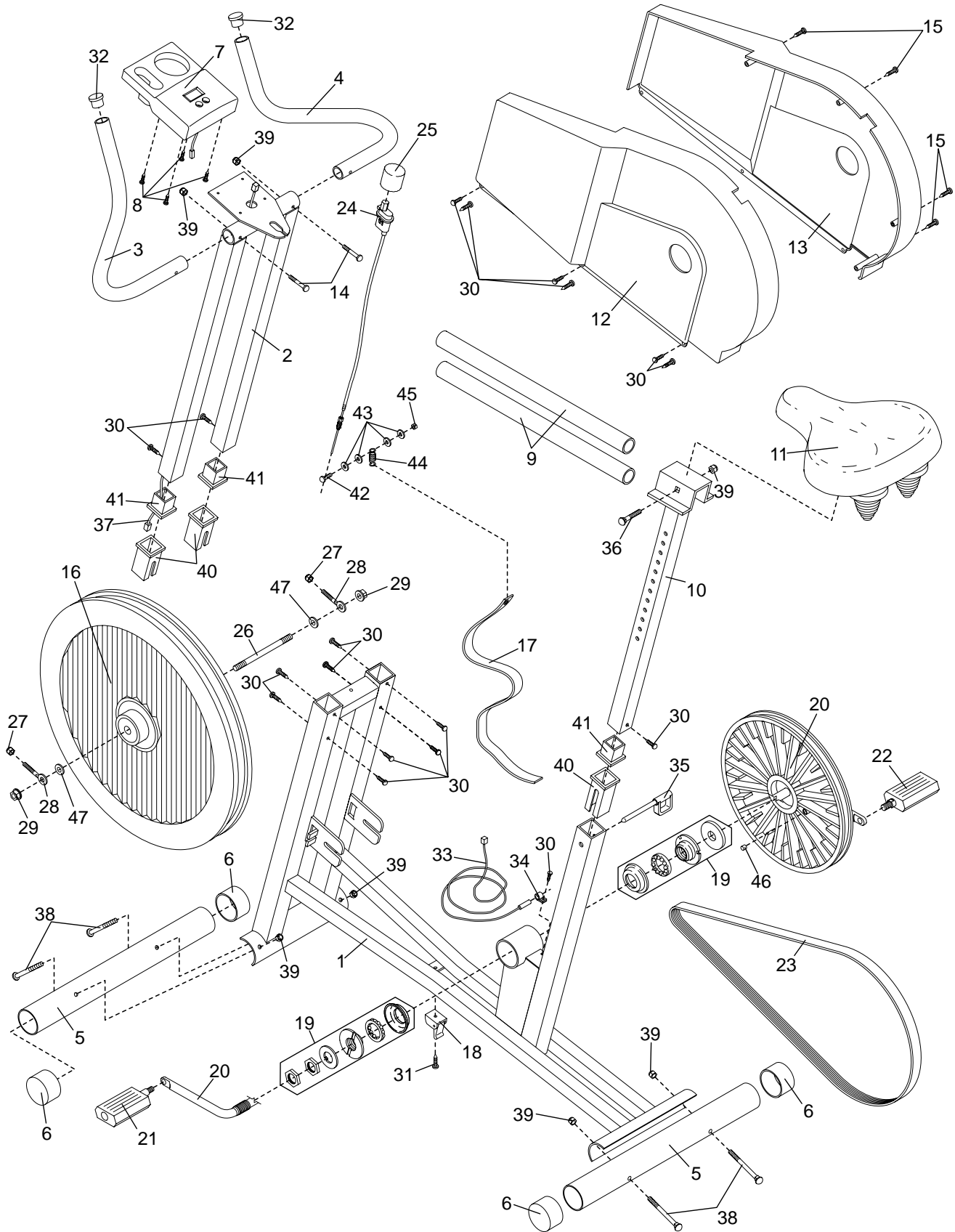



Model No. 831.288222

QUESTIONS?

If you find that:

- you need help assembling or operating the PROFORM® 928L
- a part is missing
- or you need to schedule repair service

call our toll-free HELPLINE

1-800-736-6879

Monday–Saturday, 7 am–7 pm
Central Time (excluding holidays)

REPLACEMENT PARTS

If parts become worn and need to be replaced, call the following toll-free number

1-800-FON-PART
(1-800-366-7278)

The model number and serial number of your PROFORM® 928L are listed on a decal attached to the frame. See the front cover of this manual to find the location of the decal.

All replacement parts are available for immediate purchase or special order when you visit your nearest SEARS Service Center. To request service or to order parts by telephone, call the toll-free numbers listed at the left.

When requesting help or service, or ordering parts, please be prepared to provide the following information:

- The MODEL NUMBER of the product (831.288222)
- The NAME of the product (PROFORM® 928L exercise cycle)
- The KEY NUMBER and DESCRIPTION of the PART (see the PART LIST and the EXPLODED DRAWING on pages 10 and 11).

FULL 90 DAY WARRANTY

For 90 days from the date of purchase, if failure occurs due to defect in material or workmanship in this SEARS BIKE EXERCISER, contact the nearest SEARS Service Center throughout the United States and SEARS will repair or replace the BIKE EXERCISER, free of charge.

This warranty does not apply when the BIKE EXERCISER is used commercially or for rental purposes.

This warranty gives you specific legal rights, and you may also have other rights which vary from state to state.

SEARS, ROEBUCK AND CO., DEPT. 817WA, HOFFMAN ESTATES, IL 60179