

PRO-FORM CROSS WALK[®] si

SEARS

Model No. 831.297361

Serial No. _____

The serial number can be found in the location shown below. Write the serial number in the space above.

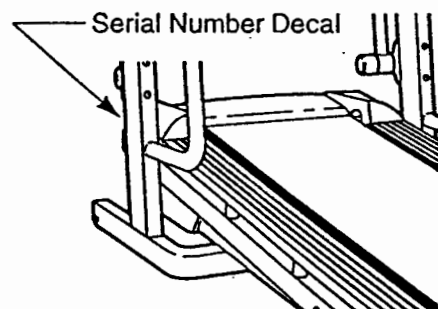

EXERCISE
EQUIPMENT

QUESTIONS

HELPLINE!

1-800-736-6879

⚠ CAUTION

Read all precautions and instructions in this manual before using this equipment. Keep this manual for future reference.

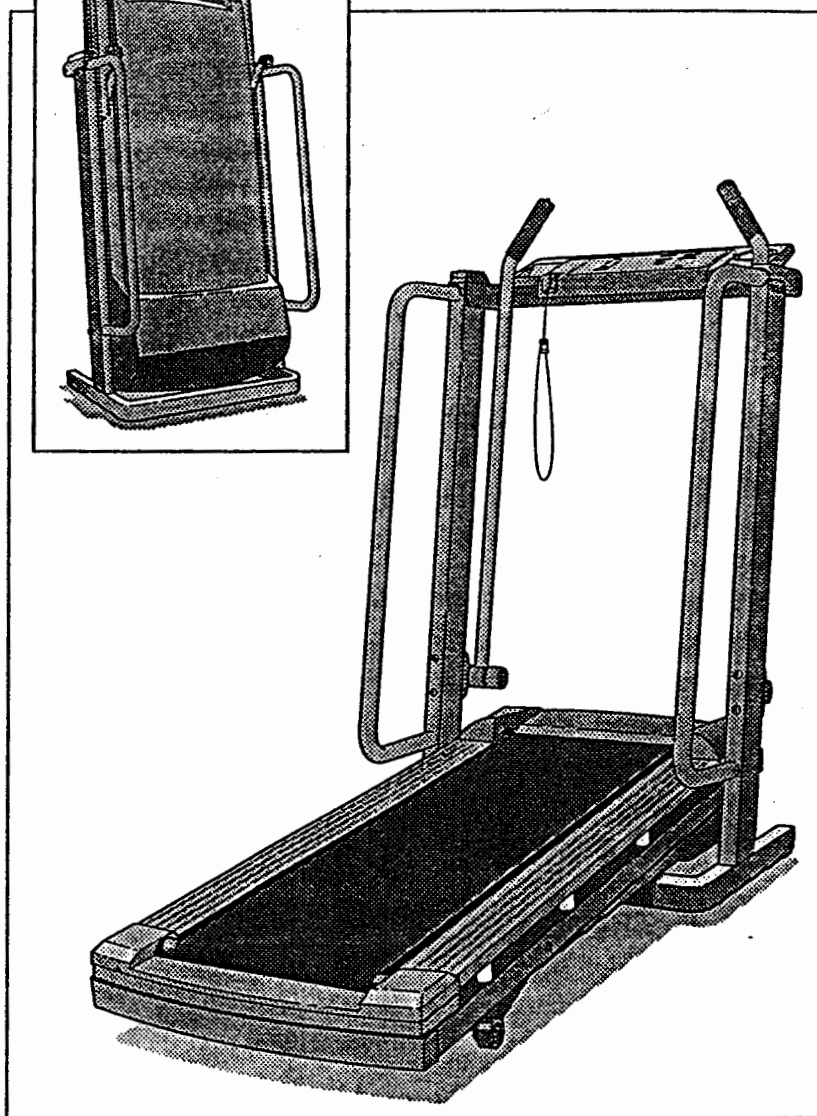
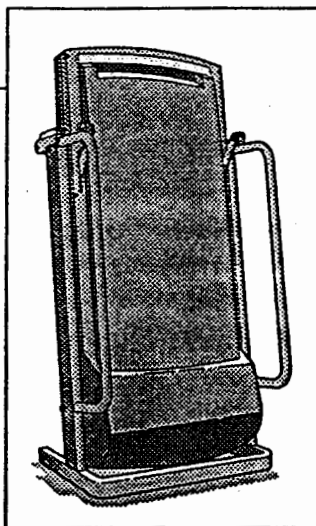

USER'S MANUAL

SEARS, ROEBUCK AND CO., HOFFMAN ESTATES, IL 60179

PRO-FORM[®] CROSS WALK[®] si

TABLE OF CONTENTS

IMPORTANT PRECAUTIONS	3
BEFORE YOU BEGIN	4
ASSEMBLY	5
OPERATION AND ADJUSTMENT	7
HOW TO FOLD AND MOVE THE TREADMILL	10
TROUBLE-SHOOTING	12
CONDITIONING GUIDELINES	14
ORDERING REPLACEMENT PARTSBack Cover
FULL 90 DAY WARRANTYBack Cover

Note: An EXPLODED DRAWING and a PART LIST are attached to the center of this manual. Save the EXPLODED DRAWING and PART LIST for future reference.

▲WARNING: Before beginning this or any exercise program, consult your physician. This is especially important for persons over the age of 35 or persons with pre-existing health problems. Read all instructions before using. SEARS assumes no responsibility for personal injury or property damage sustained by or through the use of this product.

IMPORTANT PRECAUTIONS

▲ WARNING: To reduce the risk of burns, fire, electric shock or injury to persons, read the following important precautions and information before operating the treadmill.

1. It is the responsibility of the owner to ensure that all users of this treadmill are adequately informed of all warnings and precautions.
2. Use the treadmill only as described in this manual.
3. Place the treadmill on a level surface, with eight feet of clearance behind it. Do not place the treadmill on any surface that blocks air openings. To protect the floor or carpet from damage, place a mat under the treadmill.
4. Keep the treadmill indoors, away from moisture and dust. Do not put the treadmill in a garage or covered patio, or near water.
5. Do not operate the treadmill where aerosol products are used or where oxygen is being administered.
6. Keep small children and pets away from the treadmill at all times.
7. The treadmill should be used only by persons weighing 250 pounds or less. Do not allow more than one person on the treadmill at a time.
8. Wear appropriate exercise attire when using the treadmill. Do not wear loose clothing that could become caught in the treadmill. Athletic support clothes are recommended for both men and women. *Always wear athletic shoes. Never use the treadmill with bare feet, wearing only stockings, or in sandals.*
9. When connecting the power cord (see HOW TO PLUG IN THE POWER CORD on page 7), plug the power cord into a surge protector (not included) and plug the surge protector into a grounded circuit capable of carrying 15 or more amps. No other appliance should be on the same circuit.
10. Use only a UL-listed surge protector, rated at 15 amps, with a 14-gauge cord of five feet or less in length. Do not use an extension cord.
11. Never move the walking belt while the power is turned off. Do not operate the treadmill if the power cord or plug is damaged, or if the treadmill is not working properly. (See BEFORE YOU BEGIN on page 4 if the treadmill is not working properly.)
12. Keep the power cord and the surge protector away from heated surfaces.
13. Never start the treadmill while you are standing on the walking belt. Always hold the handrails or upper body arms while using the treadmill.
14. The treadmill is capable of high speeds. Adjust the speed in small increments to avoid sudden jumps in speed.
15. To reduce the possibility of the treadmill overheating, do not operate the treadmill continuously for longer than 1 hour.
16. The pulse sensor is not a medical device. Various factors, including the user's movement, may affect the accuracy of heart rate readings. The pulse sensor is intended only as an exercise aid in determining heart rate trends in general.
17. Never leave the treadmill unattended while it is running. Always remove the key when the treadmill is not in use.
18. You must be able to safely lift 45 pounds (20 kg) to raise, lower, or move the treadmill.
19. When storing the treadmill, make sure that the storage latch is fully closed.
20. Inspect and tighten all parts of the treadmill every three months.
21. Never insert any object into any opening.
22. Always unplug the power cord before performing the maintenance and adjustment procedures described in this manual. Never remove the motor hood unless instructed to do so by an authorized service representative. Servicing other than the procedures in this manual should be performed by an authorized service representative only.

SAVE THESE INSTRUCTIONS

BEFORE YOU BEGIN

Thank you for selecting the unique PROFORM® CROSSWALK si treadmill. The CROSSWALK si treadmill blends advanced technology with innovative styling to provide you with an excellent form of cardiovascular exercise in the convenience and privacy of your home. The CROSSWALK si offers an impressive array of features designed to make your workouts more enjoyable and effective. And when you're not exercising, the unique CROSSWALK si can be folded up, requiring less than half the floor space of other treadmills.



For your benefit, read this manual carefully before using the treadmill. If you have additional questions,

please call our toll-free HELPLINE at 1-800-736-6879, Monday through Saturday, 7 a.m. until 7 p.m. Central Time (excluding holidays). To help us assist you, please note the product model number and serial number before calling. The model number of the treadmill is 831.297361. The serial number can be found on a decal attached to the treadmill (see the front cover of this manual for the location).

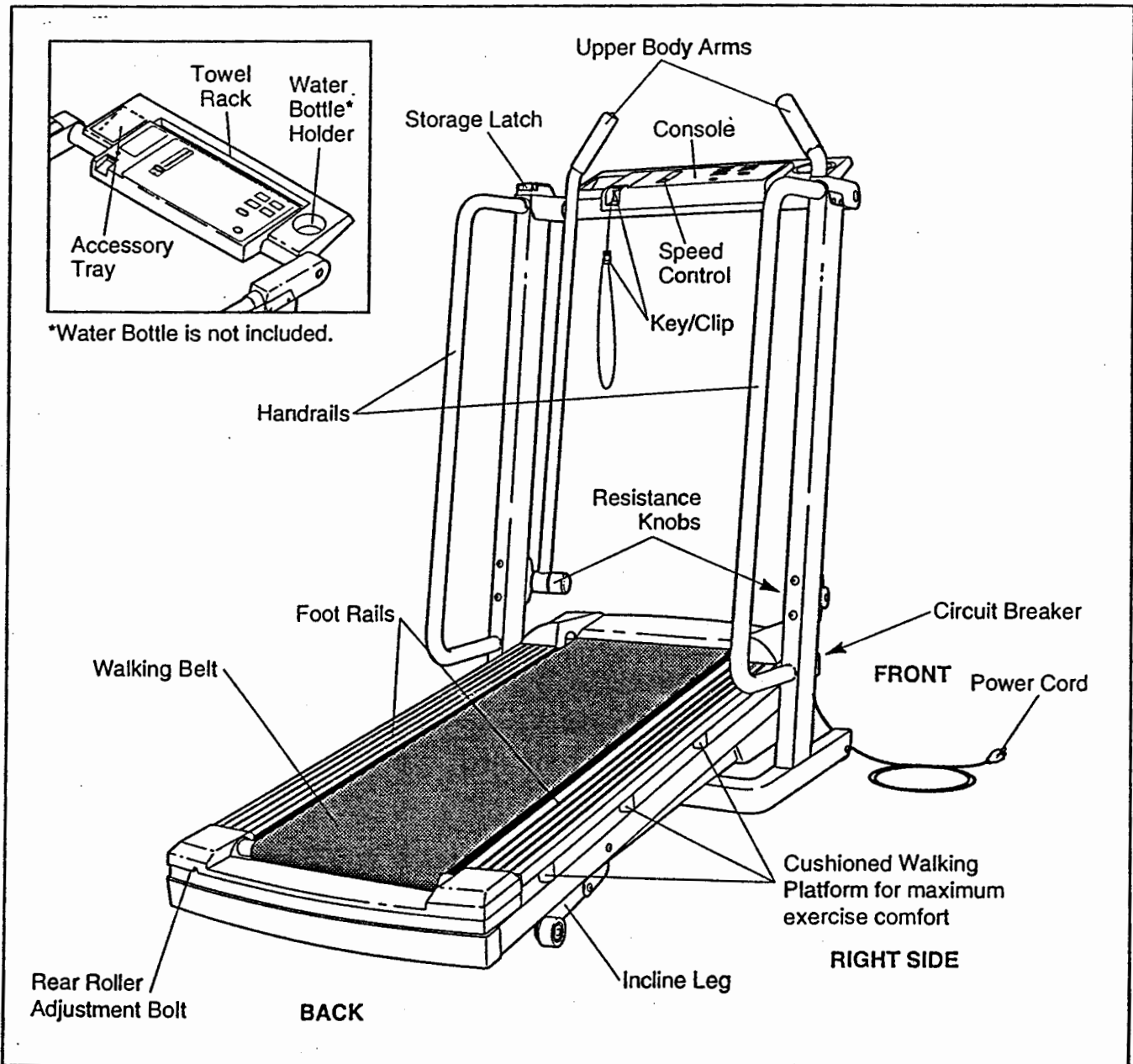
Before reading further, please review the drawing below and familiarize yourself with the parts that are labeled.

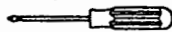

ASSEMBLY

Assembly requires two people. Set the treadmill in a cleared area and remove all packing materials. Do not dispose of the packing materials until assembly is completed. Tools required for assembly: The included allen wrench  and your phillips screwdriver  and two adjustable wrenches .

1. Attach six Base Pads (95) to the bottom of the Base (73) in the indicated locations (see the inset drawing). Note: One additional Base Pad will be used in assembly step 6, and one extra Base Pad is included.

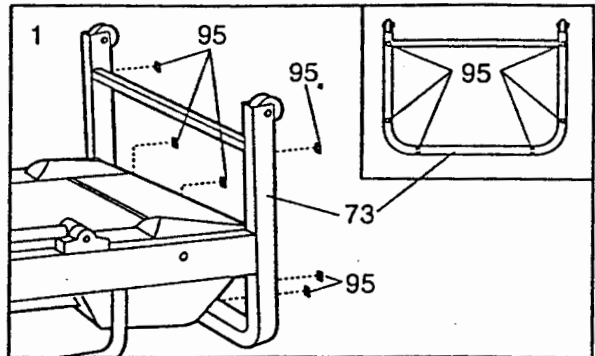

2. Firmly hold the Uprights (6, 88) as shown. Raise the Uprights until the Base (73) and the front Wheels (58) are resting on the floor.

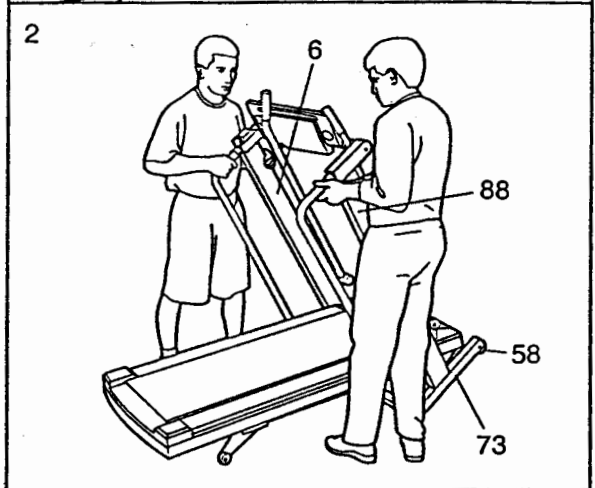

3. Loosen the Crossbar Bolts (1) in the ends of the Console Crossbar (9). Pivot the Console (10) to the angle shown. Look under the Left and Right Crossbar Brackets (3, 36) and find the two small holes in each end of the Console Crossbar (9). Tighten Crossbar Screws (104) into all four holes.

Rotate the Console (10) upward until it stops. Using the 7/32" end of the Allen Wrench (83), tighten the Crossbar Bolts (1) in the ends of the Console Crossbar (9).

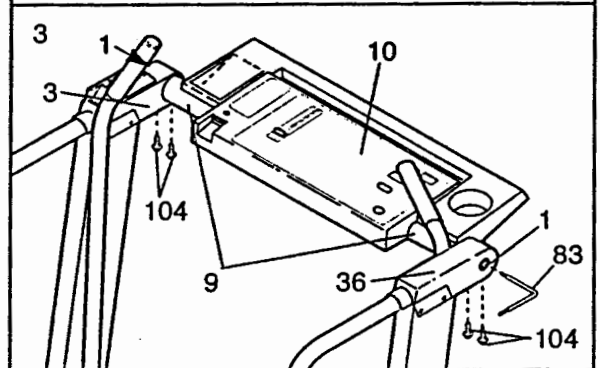

4. Next, the treadmill should be raised to the storage position. Hold the treadmill with your hands in the locations shown at the right. To decrease the possibility of Injury, bend your legs and keep your back straight. As you raise the treadmill, make sure to lift with your legs rather than your back. Raise the treadmill about halfway to the vertical position.

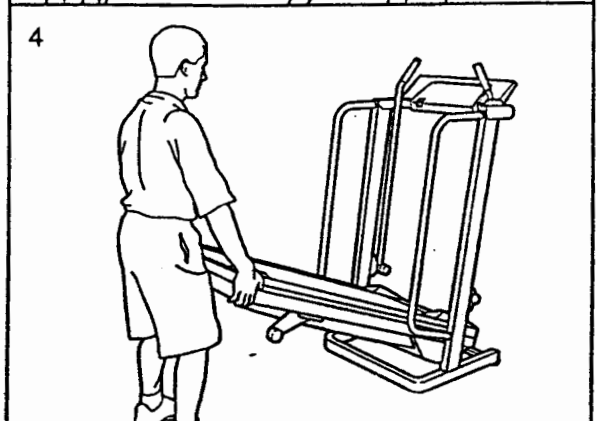

5. Move your right hand to the position shown at the right, and hold the treadmill firmly. Using your left hand, lift the storage latch. Raise the treadmill until the locking pin snaps into the storage latch. Make sure that the locking pin is inside the storage latch, and that the storage latch is fully closed.

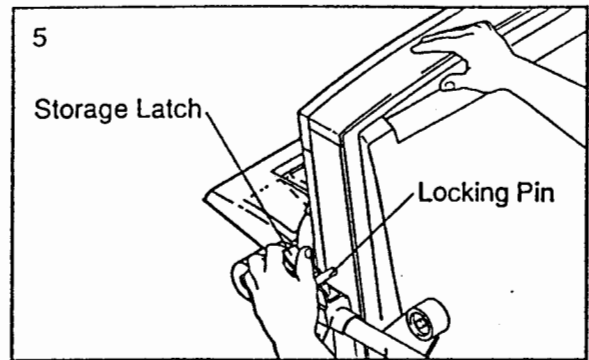

6. See drawing 6B. Attach a Base Pad (95) to the bottom of the Stabilizer Plate (94) in the indicated location.

See drawing 6A. Stand behind the treadmill. Hold the Left Crossbar Bracket (3) and the Right Crossbar Bracket (not shown). Place one foot on the Base (73) in the indicated location. Tip the treadmill back slightly. While the treadmill is held in this position, a second person should slide the Stabilizer Plate (94) onto the Base (see drawing 6C). Keeping your foot on the Base, carefully tip the treadmill up until it is resting on the Base. Make sure that the Stabilizer Plate (94) stays on the Base.

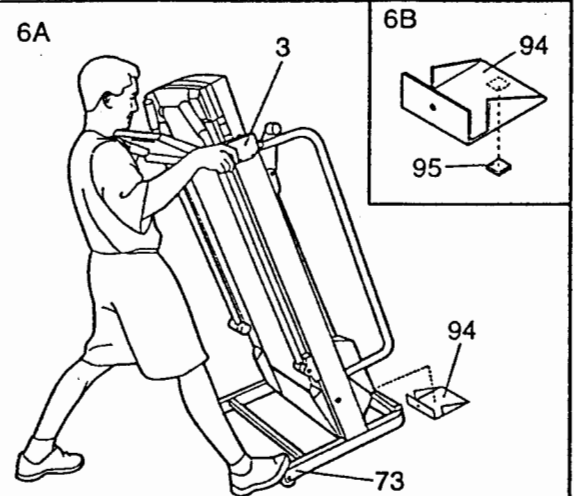

See drawing 6C. Attach the Stabilizer Plate (94) to the Base with a Stabilizer Plate Bolt (71), two Stabilizer Plate Washers (66), and the Stabilizer Plate Nut (60) as shown.

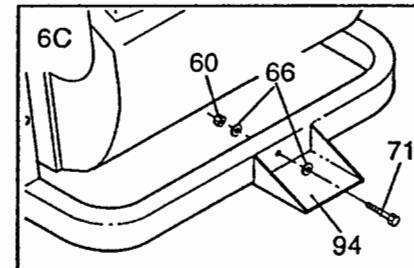

7. Refer to assembly drawing 5 at the top of this page. Hold the upper end of the treadmill with your right hand as shown. Using your left hand, lift the storage latch. Pivot the treadmill slightly until the locking pin is out of the storage latch.

Hold the treadmill firmly with both hands, and lower the treadmill to the floor. To decrease the possibility of injury, bend your legs and keep your back straight.

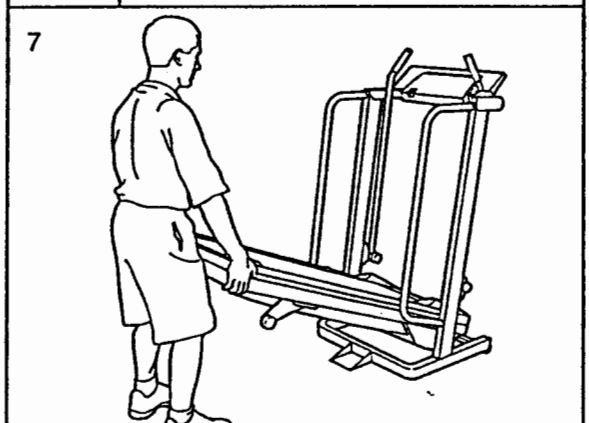

8. Remove the paper backing from the Adhesive Clip (26). Press the Adhesive Clip onto the Frame (84) in the indicated location. Press the Allen Wrench (57) into the Adhesive Clip. The use of the Allen Wrench is described on page 12.

Make sure that all parts are tightened before you use the treadmill. **Note: To protect the floor or carpet, place a mat under the treadmill.**

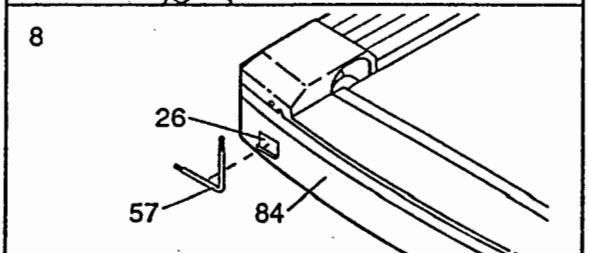

OPERATION AND ADJUSTMENT

THE PERFORMANT LUBE™ WALKING BELT

Your treadmill features a walking belt coated with PERFORMANT LUBE™, a high-performance lubricant. **IMPORTANT:** Never apply silicone spray or other substances to the walking belt or the walking platform. They will deteriorate the walking belt and cause excessive wear.

HOW TO PLUG IN THE POWER CORD

⚠ DANGER: Improper connection of the equipment-grounding conductor can result in an increased risk of electric shock. Check with a qualified electrician or serviceman if you are in doubt as to whether the product is properly grounded. Do not modify the plug provided with the product—if it will not fit the outlet, have a proper outlet installed by a qualified electrician.

Your treadmill, like any other type of sophisticated electronic equipment, can be seriously damaged by sudden voltage changes in your home's power. Voltage surges, spikes, and noise interference can result from weather conditions or from other appliances being turned on or off.

To decrease the possibility of your treadmill being damaged, always use a surge protector (not included) with your treadmill.

Surge protectors are sold at most hardware stores and department stores. Use only a UL-listed surge protector, rated at 15 amps, with a 14-gauge cord of five feet or less in length.

This product must be grounded. If it should malfunction or break down, grounding provides a path of least resistance for electric current to reduce the risk of

electric shock. This product is equipped with a cord having an equipment-grounding conductor and a grounding plug. Plug the power cord into a surge protector, and plug the surge protector into an appropriate outlet that is properly installed and grounded in accordance with all local codes and ordinances.

This product is for use on a nominal 120-volt circuit, and has a grounding plug that looks like the plug illustrated in drawing 1 below. A temporary adapter that looks like the adapter illustrated in drawing 2 may be used to connect the surge protector to a 2-pole receptacle as shown in drawing 2 if a properly grounded outlet is not available.

The temporary adapter should be used only until a properly grounded outlet (drawing 1) can be installed by a qualified electrician.

The green-colored rigid ear, lug, or the like extending from the adapter must be connected to a permanent ground such as a properly grounded outlet box cover. Whenever the adapter is used it must be held in place by a metal screw. Some 2-pole receptacle outlet box covers are not grounded. Contact a qualified electrician to determine if the outlet box cover is grounded before using an adapter.

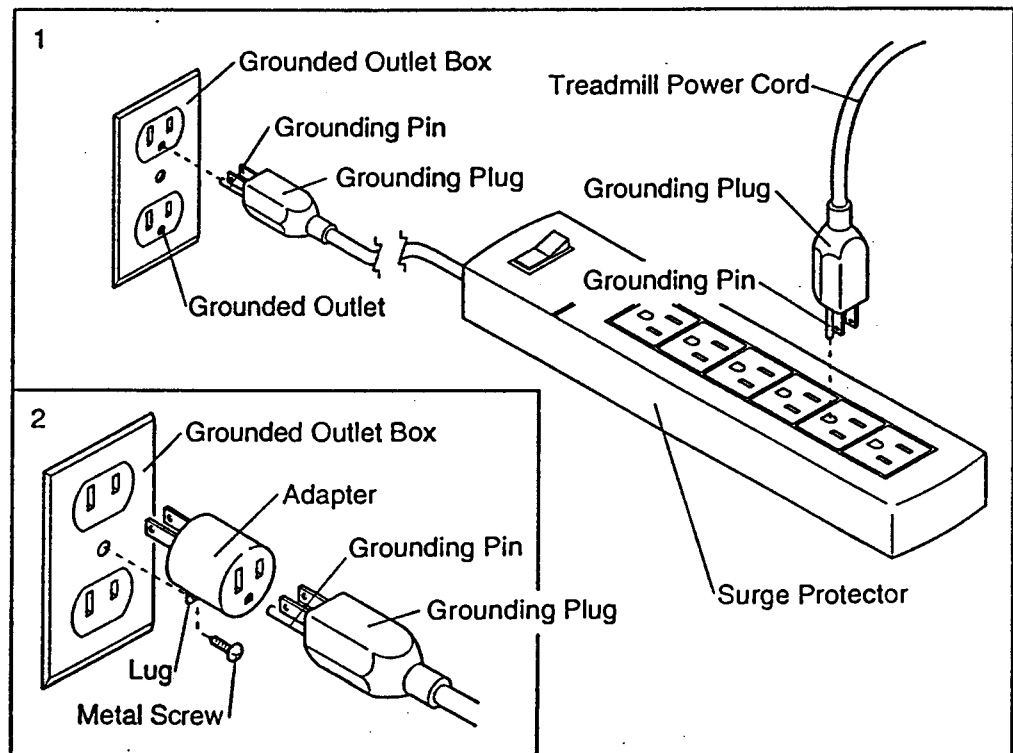
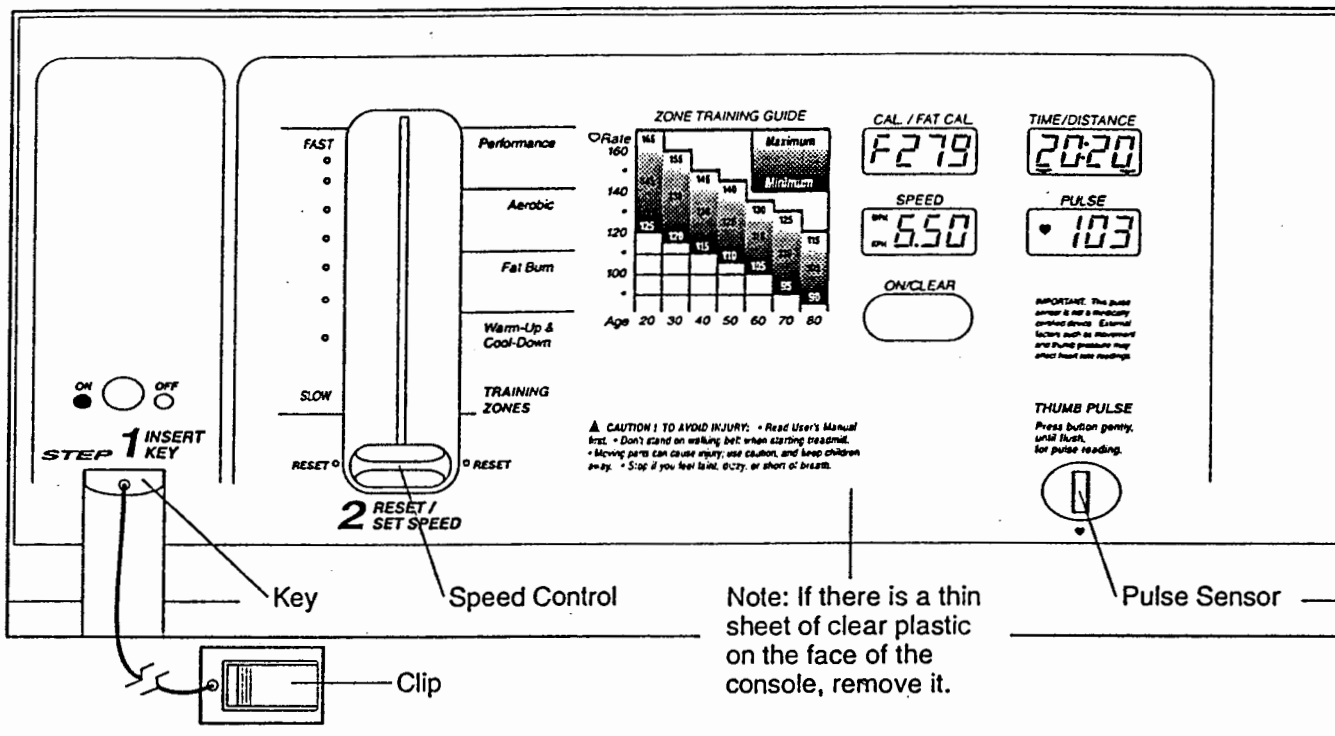

DIAGRAM OF THE CONSOLE



CAUTION: Before operating the console, read the following precautions:

- Do not stand on the walking belt when turning on the power.
- Always wear the clip (see the drawing above) while operating the treadmill. When the key is removed from the console, the walking belt will stop.
- Adjust the speed in small increments until you are familiar with the treadmill.
- The training zones marked beside the speed control are general guidelines only. See pages 14 and 15 for more information.
- To reduce the possibility of electric shock, keep the console dry. Avoid spilling liquids on the console, and use only a sealed water bottle.

Press three batteries into the battery compartment, with the negative (-) ends of the batteries touching the springs. Close the battery cover.

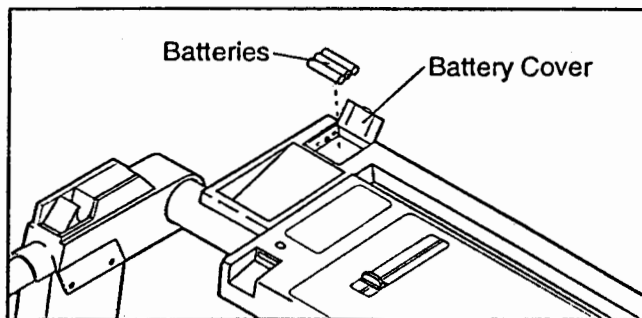

Next, step onto the foot rails of the treadmill. Find the clip attached to the key (see the drawing at the top of this page), and slide the clip onto the waistband of your clothing.

Follow the steps below and on page 9 to operate the console.

STEP BY STEP CONSOLE OPERATION

Before operating the console, make sure that the power cord is properly plugged in. (See HOW TO PLUG IN THE POWER CORD on page 7.)

The console requires three "AA" batteries (not included); alkaline batteries are recommended. Open the battery cover as shown in the drawing at the upper right.

1 Insert the key fully into the power switch.

Inserting the key will not turn on the displays. The displays will turn on when the ON/CLEAR button is pressed or the walking belt is started. Note: If you just installed batteries, the displays will already be on.

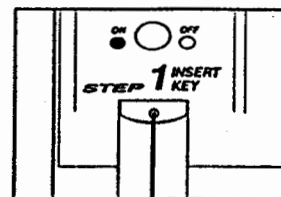

2 Reset the speed control and start the walking belt.

Slide the speed control down to the "RESET" position. **Note:** Each time the walking belt is stopped, the speed control must be moved to the "RESET" position before the walking belt can be restarted. Next, slide the control up until the walking belt begins to move at slow speed.

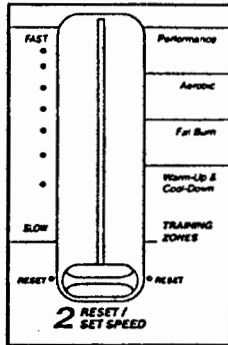

Carefully step onto the walking belt and begin exercising. Change the speed of the walking belt as desired by sliding the speed control. To stop the walking belt, step onto the foot rails and slide the speed control to the "RESET" position.

3 Follow your progress with the monitor displays.

• CAL/FAT CAL.

This display shows both the numbers of Calories and Fat Calories you have burned (see FAT BURNING on page 14). Every seven seconds, the display will change from one number to the other. An "F" will appear when the number of Fat Calories is shown. **Note:** The actual numbers of Calories and Fat Calories you burn may vary slightly from the numbers shown, depending on the speed and incline of the treadmill.



• TIME/DISTANCE

This display shows both the elapsed time and the total distance you have walked or run. Every seven seconds, the display will change from one number to the other. When the elapsed time is displayed, the left mode indicator will appear; when the total distance is displayed, the right mode indicator will appear.



• SPEED

This display shows the speed of the walking belt, in miles per hour or kilometers per hour. An MPH or a KPH will appear in the display to show which unit of measurement is selected.



To change the unit of measurement, hold down the ON/CLEAR button for five seconds. An MPH or a KPH will appear in the SPEED display to show

which unit of measurement you have selected. **Note:** If MPH is selected, the distance will also be displayed in miles; if KPH is selected, the distance will be displayed in kilometers (see TIME/DISTANCE on this page).

The displays can be reset, if desired, by pressing the ON/CLEAR button.

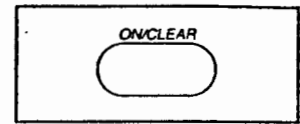

4 Measure your pulse, if desired.

To use the pulse sensor, stand on the foot rails and place your thumb on the pulse sensor as shown. The pulse sensor is pressure-activated.

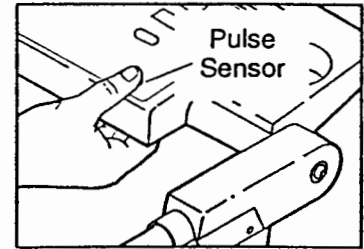

Fully press down the pulse sensor. Do not press too hard, or the circulation in your thumb will be restricted, and your pulse will not be detected. Next, slightly raise your thumb until the heart-shaped indicator in the PULSE display flashes steadily. Hold your thumb at this level. After 5 to 10 seconds, your pulse will be shown in the PULSE display. Hold your thumb on the sensor for another 15 seconds for the most accurate reading. If the displayed pulse appears to be too high or too low, or if your pulse is not displayed, lift your thumb off the sensor and allow the display to reset. Press down again on the sensor as described above.

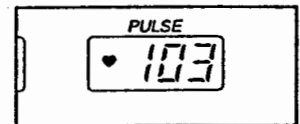

Make sure that your thumb is positioned as shown, and that you are applying the proper amount of pressure to the pulse sensor. Try the sensor several times until you become familiar with it. Remember to stand still while measuring your pulse.

5 When you are finished exercising, stop the walking belt and remove the key.

Step onto the foot rails, stop the walking belt, and remove the key from the console. Store the key in a secure place.

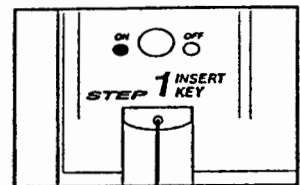

Note: After the key is removed, the displays will remain on for about four minutes.

HOW TO USE THE UPPER BODY ARMS

As you exercise on the treadmill, you can hold either the handrails or the upper body arms. The upper body arms are designed to exercise your arms, shoulders, and back for a total body workout. Hold one upper body arm with each hand, and move the arms forward and back as you walk on the treadmill.

To vary the intensity of your upper body exercise, the resistance of the upper body arms can be adjusted. To increase the resistance, turn the resistance knobs clockwise; to decrease the resistance, turn the knobs counter-clockwise.

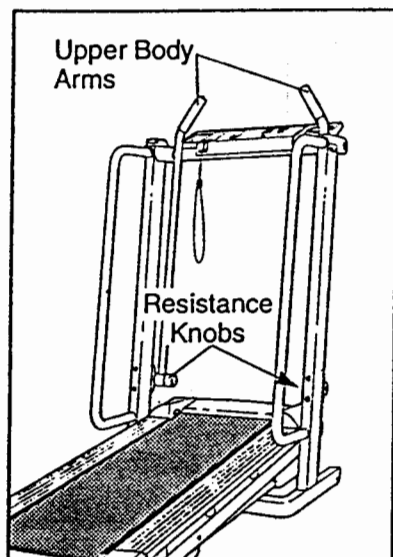

HOW TO CHANGE THE INCLINE OF THE TREADMILL

The incline of the treadmill can be changed by raising or lowering the back end. Before changing the incline, remove the key and unplug the power cord.

Hold the back end of the treadmill frame with both hands. When the back end of the treadmill is in the lowest position, the incline is about 10%. Raise the back end until both incline legs click into position. The incline will then be about 5%. Raise the back end again until the incline legs click into position. The incline will then be about 3%. To lower the back end, first raise it past the highest position, and then lower it. **CAUTION:** Before exercising, push on the back of the treadmill to make sure that the incline legs are locked in position. Both incline legs must be at the same level.

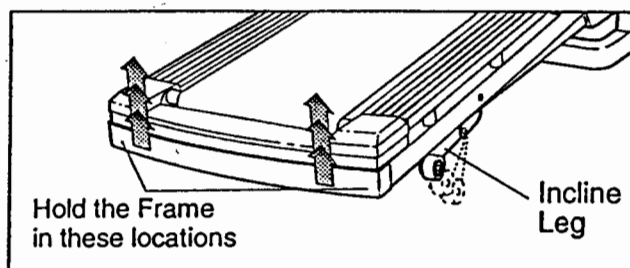

HOW TO FOLD AND MOVE THE TREADMILL

HOW TO FOLD THE TREADMILL FOR STORAGE

Before folding the treadmill, unplug the power cord. **Caution:** You must be able to safely lift 45 pounds (20 kg) in order to raise, lower, or move the treadmill.

1. Hold the treadmill with your hands in the locations shown at the right. To decrease the possibility of injury, bend your legs and keep your back straight. As you raise the treadmill, make sure to lift with your legs rather than your back. Raise the treadmill about halfway to the vertical position.

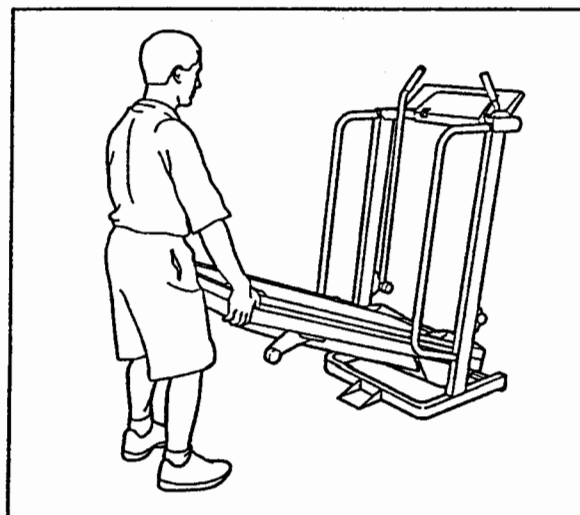

2. Move your right hand to the position shown at the right, and hold the treadmill firmly. Using your left hand, lift the storage latch. Raise the treadmill until the locking pin snaps into the storage latch. **Make sure that the locking pin is inside the storage latch, and that the storage latch is fully closed.**

To protect the floor or carpet from damage, place a mat under the treadmill. Keep the treadmill out of direct sunlight. Do not leave the treadmill in the storage position in temperatures above 85° Fahrenheit.

HOW TO MOVE THE TREADMILL

Before moving the treadmill, convert the treadmill to the storage position as described on pages 10 and 11.

1. Hold one crossbar bracket with each hand. Place one foot on the base as shown.
2. Tilt the treadmill back until it rolls freely on the front wheels. Carefully move the treadmill to the desired location. **To reduce the risk of injury, use extreme caution while moving the treadmill. Do not attempt to move the treadmill over an uneven surface.**
3. Place one foot on the base, and carefully lower the treadmill until it is resting in the storage position.

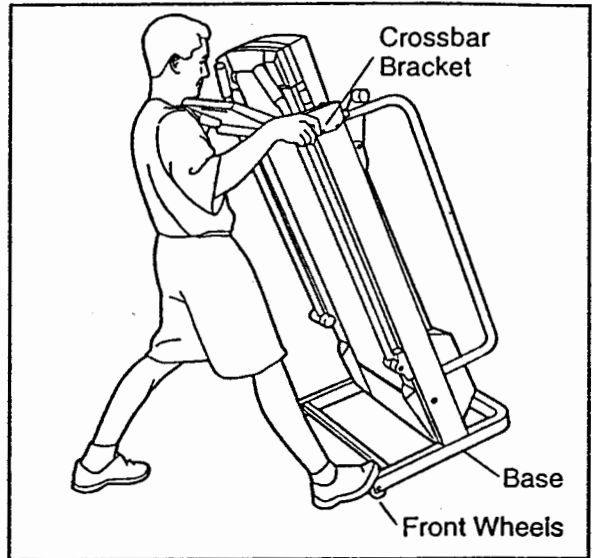
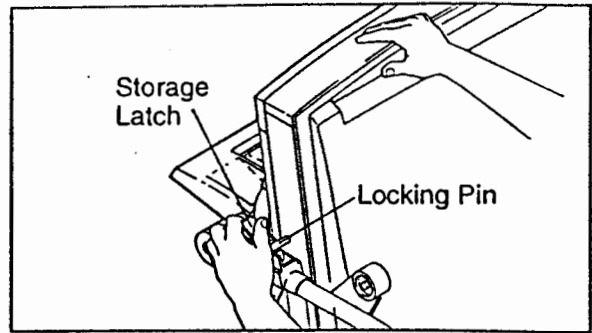

HOW TO LOWER THE TREADMILL FOR USE

1. Hold the upper end of the treadmill with your right hand as shown. Using your left hand, lift the storage latch. Pivot the treadmill slightly until the locking pin is out of the storage latch.
2. Hold the treadmill firmly with both hands, and lower the treadmill to the floor. **To decrease the possibility of injury, bend your legs and keep your back straight.**

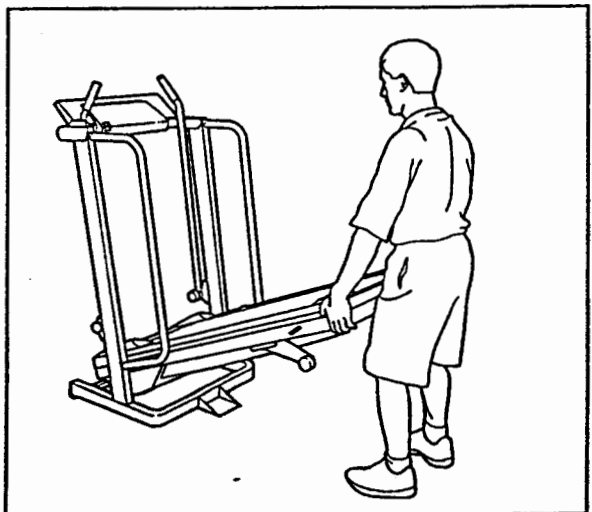
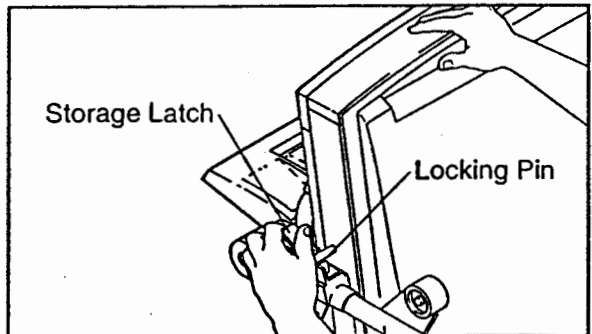

TROUBLE-SHOOTING

Most treadmill problems can be solved by following the simple steps below. Find the symptom that applies, and follow the steps listed. If further assistance is needed, call our toll-free HELPLINE at 1-800-736-6879, Monday through Saturday, 7 a.m. until 7 p.m. Central Time (excluding holidays).

1. SYMPTOM: THE POWER DOES NOT TURN ON

- a. Make sure that the power cord is plugged into a surge protector, and that the surge protector is plugged into a properly grounded outlet. (See HOW TO PLUG IN THE POWER CORD on page 7.) Use only a UL-listed surge protector, rated at 15 amps, with a 14-gauge cord of five feet or less in length.
- b. After the power cord has been plugged in, make sure that the key is fully inserted into the console. (See step 1 on page 8.)
- c. Check the circuit breaker located on the treadmill near the power cord. If the switch protrudes as shown, the circuit breaker has tripped. To reset the circuit breaker, wait for five minutes and then press the switch back in.

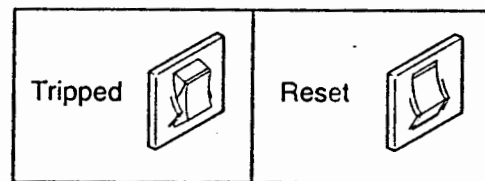

2. SYMPTOM: THE POWER TURNS OFF DURING USE

- a. Check the circuit breaker located on the treadmill frame near the power cord (see 1. c. above). If the circuit breaker has tripped, wait for five minutes and then press the switch back in.
- b. Make sure that the power cord is plugged in.
- c. Remove the key from the console. Reinsert the key fully into the console. (See step 1 on page 8.)
- d. If the treadmill still will not run, please call our toll-free HELPLINE.

3. SYMPTOM: THE WALKING BELT SLOWS WHEN WALKED ON

- a. Use only a UL-listed surge protector, rated at 15 amps, with a 14-gauge cord of five feet or less in length.
- b. If the walking belt still slows when walked on, please call our toll-free HELPLINE.

4. SYMPTOM: THE WALKING BELT IS OFF-CENTER OR SLIPS WHEN WALKED ON

- a. If the walking belt has shifted to the left, first remove the key and **UNPLUG THE POWER CORD**. Using the 3/16" end of the allen wrench, turn the left rear roller adjustment bolt clockwise 1/4 of a turn. Plug in the power cord, insert the key and run the treadmill for a few minutes. Repeat until the walking belt is centered.

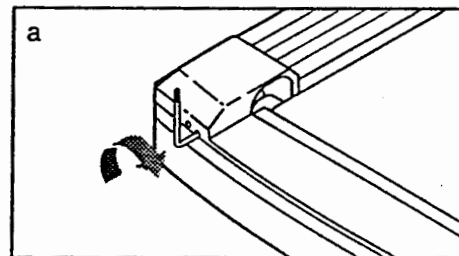

- b. If the walking belt has shifted to the right, first remove the key and **UNPLUG THE POWER CORD**. Using the 3/16" end of the allen wrench, turn the left rear roller adjustment bolt counter-clockwise 1/4 of a turn. Plug in the power cord, insert the key and run the treadmill for a few minutes. Repeat until the walking belt is centered.

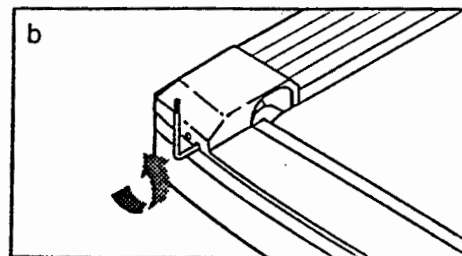

5. SYMPTOM: THE DISPLAYS OF THE CONSOLE DO NOT FUNCTION PROPERLY

- a. The console requires three "AA" batteries (not included); alkaline batteries are recommended. If the displays of the console do not function properly, the batteries should be replaced. Open the battery cover as shown at the right. Press three batteries into the battery compartment, with the negative (-) ends of the batteries touching the springs. Close the battery cover.

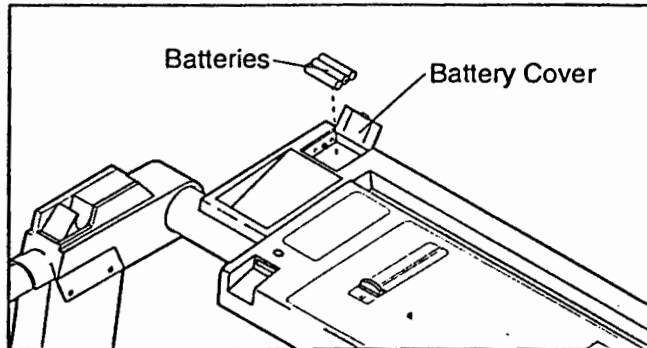

6. SYMPTOM: ONE OF THE UPPER BODY ARMS SQUEAKS DURING USE

- a. Correcting this problem requires a small amount of white marine grease, available at most department stores.

Turn the Resistance Knob (101) counterclockwise until it can be removed. Remove the Resistance Cone (100) and the Upper Body Arm (102), along with the Resistance Washers (108), Spring Washer (111), Thrust Washers (109), and Thrust Bearing (110). (Note: If the Resistance Sleeve [99] comes out of the Resistance Bracket [97], press it back in.) Apply a thin layer of white marine grease to the outer surface of the Resistance Cone (100). Reattach all parts in the order shown at the right.

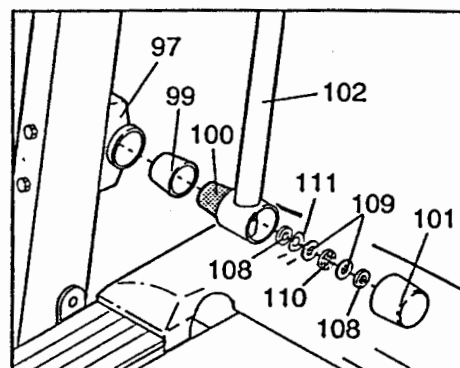

CONDITIONING GUIDELINES

⚠ WARNING: Before beginning this or any exercise program, consult your physician. This is especially important for individuals over the age of 35 or individuals with pre-existing health problems.

The pulse sensor is not a medical device. Various factors, including your movement, may affect the accuracy of heart rate readings. The sensor is intended only as an exercise aid in determining heart rate trends in general.

The following guidelines will help you to plan your exercise program. Remember—these are general guidelines. For more detailed information about exercise, obtain a reputable book or consult your physician.

EXERCISE INTENSITY

Whether your goal is to burn fat or to strengthen your cardiovascular system, the key to achieving the desired results is to exercise with the proper intensity. The proper intensity level can be found by using your heart rate as a guide.

The chart below shows recommended heart rates for fat burning, aerobic exercise, and high performance athletic conditioning. (This chart is also found on the console.)

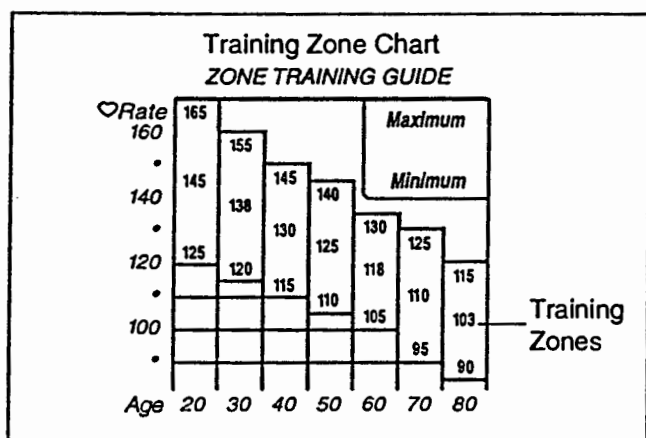

To find the proper heart rate for you, first find your age near the bottom of the chart (ages are rounded off to the nearest ten years). Next, look above your age and find the box containing three numbers. The three numbers are your "training zone." The lowest number is the recommended heart rate for fat burning; the middle number is the recommended heart rate for aerobic exercise; the highest number is the recommended heart rate for high performance athletic conditioning.

Fat Burning

To burn fat effectively, you must exercise at a relatively low intensity level for a sustained period of time. During the first few minutes of exercise, your body uses easily accessible *carbohydrate calories* for energy. Only after the first few minutes does your body begin to use stored *fat calories* for energy. If your goal is to burn fat, adjust the speed and incline of the treadmill until your heart rate is near the lowest number in your training zone as you exercise. It may also be helpful to set the speed control on the console to **FAT BURN** to help you maintain the proper intensity level. (See page 8.)

Aerobic Exercise

If your goal is to strengthen your cardiovascular system, your exercise must be "aerobic." Aerobic exercise is activity that requires large amounts of oxygen for prolonged periods of time. This increases the demand on the heart to pump blood to the muscles, and on the lungs to oxygenate the blood. For aerobic exercise, adjust the speed and incline of the treadmill until your heart rate is near the middle number in your training zone. It may also be helpful to set the speed control on the console to **AEROBIC** to help you maintain the proper intensity level. (See page 8.)

High Performance Athletic Conditioning

If your goal is high performance athletic conditioning, adjust the speed and incline of the treadmill until your heart rate is near the highest number in your training zone. It may also be helpful to set the speed control on the console to **PERFORMANCE** to help you maintain the proper intensity level. (See page 8.)

HOW TO MEASURE YOUR HEART RATE

You can measure your heart rate using the pulse sensor on the console. Exercise for about four minutes, and then measure your heart rate immediately. If your heart rate is too high or too low, adjust the speed and incline of the treadmill until your heart rate is at the proper level.

WORKOUT GUIDELINES

A well-rounded workout includes three phases:

A warm-up phase, lasting 5 to 10 minutes. Begin with slow, controlled stretches, and progress to more rhythmic stretches to increase the body temperature, heart rate and circulation in preparation for strenuous exercise. Stretching also guards against muscle, tendon and ligament sprains.

A cardiovascular phase, including 20 to 30 minutes of exercising with your heart rate in your training zone. (See EXERCISE INTENSITY on page 14 to find your training zone.)

A cool-down phase, consisting of 5 to 10 minutes of stretching. Thorough stretching offsets muscle contractions and other problems caused when you stop exercising suddenly. Stretching for increased flexibility is also most effective during this phase. This phase should leave you relaxed and comfortably tired.

To maintain or improve your condition, plan three workouts each week, with at least one day of rest between workouts. After a few months of regular exercise, you may complete up to five workouts each week, if desired.

Remember, the key to success is make exercise a regular and enjoyable part of your everyday life.

SUGGESTED STRETCHES

The correct form for several basic stretches is shown in the drawings below. Move slowly as you stretch—never bounce.

1. Toe Touch Stretch

Stand with your knees bent slightly and slowly bend forward from your hips. Allow your back and shoulders to relax as you reach down toward your toes as far as possible. Hold for 15 counts, then relax. Repeat 3 times. Stretches: Hamstrings, back of knees and back.

2. Hamstring Stretch

Sit with one leg extended. Bring the sole of the opposite foot toward you and rest it against the inner thigh of your extended leg. Reach toward your toes as far as possible. Hold for 15 counts, then relax. Repeat 3 times for both legs. Stretches: Hamstrings, lower back and groin.

3. Calf/Achilles Stretch

With one leg in front of the other, reach forward and place your hands against a wall. Keep your back leg straight and your back foot flat on the floor. Bend your front leg, lean forward and move your hips toward the wall. Hold for 15 counts, then relax. Repeat 3 times for both legs. To cause further stretching of the achilles tendons, bend your back leg as well. Stretches: Calves, achilles tendons and ankles.

4. Quadriceps Stretch

With one hand against a wall for balance, reach back and grasp one foot with your other hand. Bring your heel as close to your buttocks as possible. Hold for 15 counts, then relax. Repeat 3 times for both legs. Stretches: Quadriceps and hip muscles.

5. Inner Thigh Stretch

Sit with the soles of your feet together and your knees outward. Pull your feet toward your groin area as far as possible. Hold for 15 counts, then relax. Repeat 3 times. Stretches: Quadriceps and hip muscles.

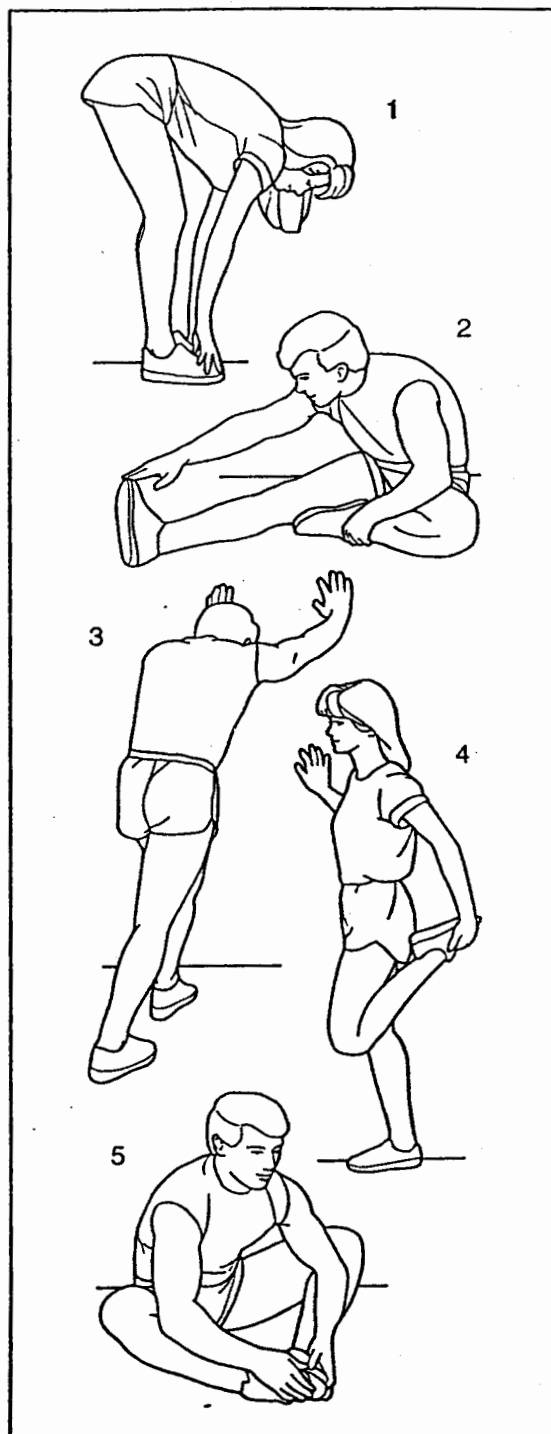



Model No. 831.297361

QUESTIONS?

If you find that:

- you need help assembling or operating the PROFORM® CROSSWALK si treadmill
- a part is missing
- or you need to schedule repair service

call our toll-free HELPLINE

1-800-736-6879

Monday-Saturday, 7 am-7 pm
Central Time (excluding holidays)

REPLACEMENT PARTS

If parts become worn and need to be replaced, call the following toll-free number

1-800-FON-PART
(1-800-366-7278)

The model number and serial number of your PROFORM® CROSSWALK si treadmill are listed on a decal attached to the frame. See the front cover of this manual to find the location of the decal.

All replacement parts are available for immediate purchase or special order when you visit your nearest SEARS Service Center. To request service or to order parts by telephone, call the toll-free numbers listed at the left.

When requesting help or service, or ordering parts, please be prepared to provide the following information:

- The NAME OF THE PRODUCT (PROFORM® CROSSWALK si treadmill)
- The MODEL NUMBER OF THE PRODUCT (831.297361)
- The PART NUMBER OF THE PART (see the EXPLODED DRAWING and PART LIST attached to the center of this manual)
- The DESCRIPTION OF THE PART (see the EXPLODED DRAWING and PART LIST attached to the center of this manual)

FULL 90 DAY WARRANTY

For 90 days from the date of purchase, if failure occurs due to defect in material or workmanship in this SEARS TREADMILL EXERCISER, contact the nearest SEARS Service Center throughout the United States and SEARS will repair or replace the TREADMILL EXERCISER, free of charge.

This warranty does not apply when the TREADMILL EXERCISER is used commercially or for rental purposes.

This warranty gives you specific legal rights, and you may also have other rights which vary from state to state.

SEARS, ROEBUCK AND CO., DEPT. 817WA, HOFFMAN ESTATES, IL 60179

REMOVE THIS EXPLODED DRAWING AND PART LIST FROM THE MANUAL

Save this EXPLODED DRAWING and PART LIST for future reference.

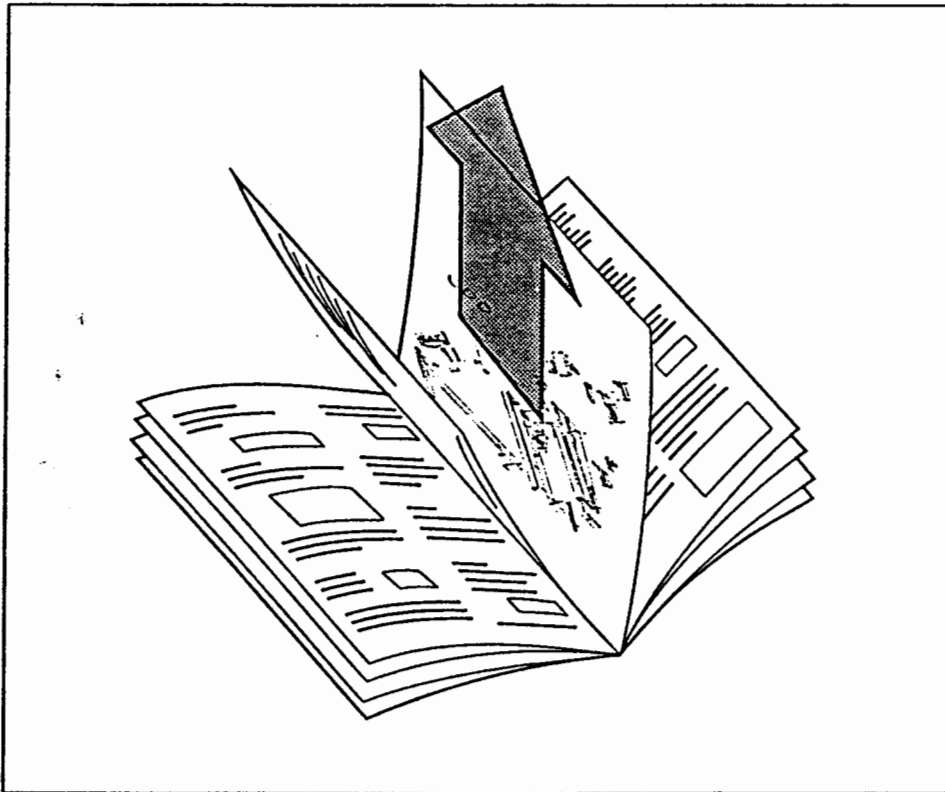

Note: Specifications are subject to change without notice. For information about ordering replacement parts, see the back cover of this manual.

PART LIST—Model No. 831.297361

R0396A

Key No.	Part No.	Qty.	Description	Key No.	Part No.	Qty.	Description
1	013438	2	Crossbar Bolt	64	111869	8	Cage Nut
2	013282	10	Crossbar Bracket Screw	65	128465	2	Crossbar Bracket
3	127091	1	Left Crossbar Bracket	66	014073	2	Stabilizer Plate Washer
4	013540	12	Console Screw	67	119425	6	Nut
5	119038	1	Key/Clip	68	128875	2	Incline Leg
6	129449	1	Left Upright	69	128260	1	Right Rear Adjustment Bolt
7	124545	1	Pot Wire Harness	70	012149	1	Motor Lock Nut
8	129824	1	100" Ground Wire	71	127948	1	Stabilizer Plate Bolt
9	129324	1	Console Crossbar	72	126572	1	Rear Hood
10*	129169	1	Console	73	129531	1	Base
11	105477	2	Motor Nut	74	105444	1	Left Rear Adjustment Bolt
12	129667	1	Motor	75	127000	1	Rear Roller
13	112825	1	Pulley/Flywheel/Fan	76	128986	1	Rear Roller Tension Spring
14	129814	1	Base Shock	77	123470	1	Spring Sleeve
15	126134	1	Motor Belt	78	119439	1	Roller Tension Nut
16	013547	7	Motor Tension Bolt/Upright Bolt	79	125860	1	Rear Roller Guard
17	122812	1	Motor Tension Washer	80	128479	4	Roller Guard
18	014117	5	Star Washer	81	013529	8	Hood Anchor Screw
19	113814	2	Motor Bolt	82	128272	8	Platform Screw
20	120867	1	Motor Tension Nut	83	128457	1	Allen Wrench
21	129028	1	Front Hood	84	016029	1	4" Wire Tie
22	129799	1	Motor Mount Bracket	85	016057	2	8" Wire Tie
23	107503	1	Motor Swivel Bolt	86	116927	1	Tie Holder Clamp
24	118153	1	Reed Switch/Sensor Wire	87	127689	8	Platform Isolator
25	100498	1	Magnet	88	129173	1	Right Upright
26	016028	2	Adhesive Clip	89	120885	1	Wire Guard
27	120630	16	Screw	90	128271	4	Incline Leg Spacer
28	054023	3	Wire Clip	91	128575	2	Incline Leg Bracket
29	127419	4	Hood Anchor	92	126960	1	Upright Plug
30	126130	1	Safety Cover Plug	93	112628	4	Wheel Spacer
31	126985	1	Electronics Bracket	94	128709	1	Stabilizer Plate
32	129843	1	Controller	95	129740	8	Base Pad
33	124544	1	Upright Wire Harness	96	126963	4	Resistance Bracket Bolt
34	031238	1	Choke	97	126773	2	Resistance Bracket
35	109382	1	Circuit Breaker	98	126644	2	Resistance Bolt
36	126641	1	Right Crossbar Bracket	99	126827	2	Resistance Sleeve
37	112609	1	Front Roller Adj. Bolt	100	126828	2	Resistance Cone
38	014127	5	Adjustment Washer	101	126843	2	Resistance Knob
39	124669	1	Power Cord	102	128598	2	Upper Body Arm
40	124695	1	Grommet	103	105500	2	Foam Grip
41	118196	1	Reed Switch Extension Wire	104	013576	4	Crossbar Screw
42	129312	1	Speed Control Knob	105	126956	1	Front Hood Spacer
43	126955	1	Safety Cover	106	126987	1	Rear Hood Spacer
44	129168	30	Safety Cover Screw	107	125802	4	Rubber Hood Mount
45	129022	1	Front Roller/Pulley	108	014132	4	3/8" Flat Washer
46	127706	1	Walking Platform	109	102973	4	Thrust Washer
47	127707	1	Walking Belt	110	106896	2	Thrust Bearing
48	129029	2	Foot Rail	111	128005	2	Spring Washer
49	NSP	1	Frame	112*	129668	1	Motor/Pulley/Flywheel/Fan
50	013544	4	Incline Leg Bolt/Wheel Bolt	113	014086	2	Crossbar Bracket Washer
51	120655	2	Incline Leg Spring	114	128265	2	Cable Loom
52	127098	2	Belt Guide	115	108080	4	Ratchet Mounting Screw
53	118570	2	Upright Pivot Washer	116	129004	2	Wire Grommet
54	126456	1	Water Bottle Insert	117	014063	4	Resistance Bracket Washer
55	012156	2	Wheel Nut	118	100553	2	Upright Pivot Nut
56	126635	2	Upright Pivot Bolt	119	128695	1	Battery Cover
57	117806	2	Incline Wheel Bolt	#	107771	1	8" White Wire, Male/Female
58	052012	4	Wheel	#	114011	1	4" Black Wire, Male/Female
59	128416	2	Incline Leg Latch	#	129610	1	User's Manual
60	012056	1	Stabilizer Plate Nut				
61	128093	1	Potentiometer				
62	116926	1	Wire Tie				
63	127544	2	Guard Spring				

* Includes all the parts shown in the box
Not illustrated